

Crestline[®] Dampening System

Installation Instructions

Hamada C248

For Presses Originally Equipped With
Hamada Watermatic



A Pamarco Technologies Inc. Company

X88-53
Rev-A
01/2001

GENERAL INFORMATION

ATTENTION CRESTLINE® DAMPENER OWNER!

Accel Graphic Systems provides parts and service through its authorized distributors and dealers. Therefore, all requests for parts and service should be directed to your local dealer.

The philosophy of Accel Graphic Systems is to continually improve all of its products. Written notices of changes and improvements are sent to Accel Graphic Systems' Dealers.

If the operating characteristics or the appearance of your product differs from those described in this manual, please contact your local Accel Graphic Systems Dealer for updated information and assistance.

Always update your dampener when improvements are made available, especially those related to safety.

YOUR AUTHORIZED CRESTLINE® DEALER IS:

THE SERIAL NUMBER OF YOUR CRESTLINE® DAMPENER(S) IS:

SAFETY INFORMATION

FOR YOUR SAFETY, DO NOT DISENGAGE OR REMOVE ANY GUARDS FROM THE CRESTLINE® DAMPENER. THE DAMPENER CONTAINS SOME INWARD ROTATING ROLLER NIPS THAT CAN CAUSE INJURY IF LEFT UNGUARDED.

GENERAL INFORMATION

BASIC CONFIGURATION OF CRESTLINE®

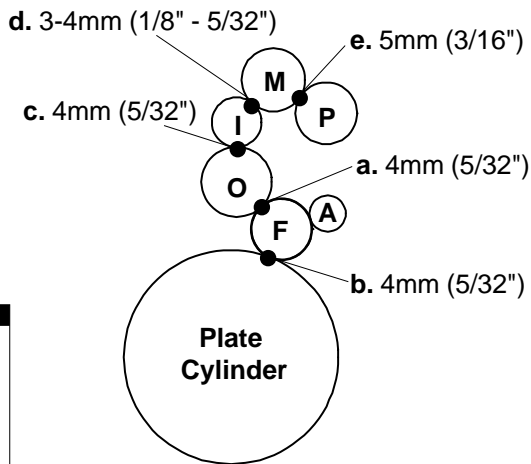

Adjustments	
a.	Oscillator to Form
b.	Form to Plate
c.	Intermediate to Oscillator
d.	Metering to Intermediate
e.	Metering to Pan

Roller Description	
P	= Pan
M	= Metering
I	= Intermediate
O	= Oscillator
F	= Form
A	= Auxiliary Rider

TERMINOLOGY **OPS** = Operator's Side

NOPS = Non Operator's Side

TECHNICAL ASSISTANCE

For technical assistance, please contact:

ACCEL GRAPHIC SYSTEMS
 11103 Indian Trail
 Dallas, TX 75229
 PHONE (972) 484-6808
 FAX (800) 365-6510
 E-MAIL accel@dallas.net
 WEB SITE www.accelgraphicsystems.com

Crestline® is covered by U.S. Patents and Patents Pending

GENERAL INFORMATION

- REQUIRED TOOLS**
1. 3mm Allen
 2. 4mm Allen
 3. 5mm Allen
 4. 6mm Allen
 5. 3/32" Allen
 6. 10mm Wrench
 7. 13mm Wrench
 8. Hammer
 9. 5/32" Punch
 10. 3/16" Punch
 11. Slotted Screwdriver
 12. Combination Pliers
 13. Snap Ring Pliers

PRE-INSTALLATION INFORMATION

1. Examine rollers for gouges, scratches, or nicks.
2. Check box and parts board to make sure all pieces are present and nothing had broken in shipping.
3. Check the dampener for parallel (cutter bed works best). If dampener rocks, it needs to be realigned. Loosen tie bar bolts at OPS and align the frames on the flat surface. Retighten bolts.

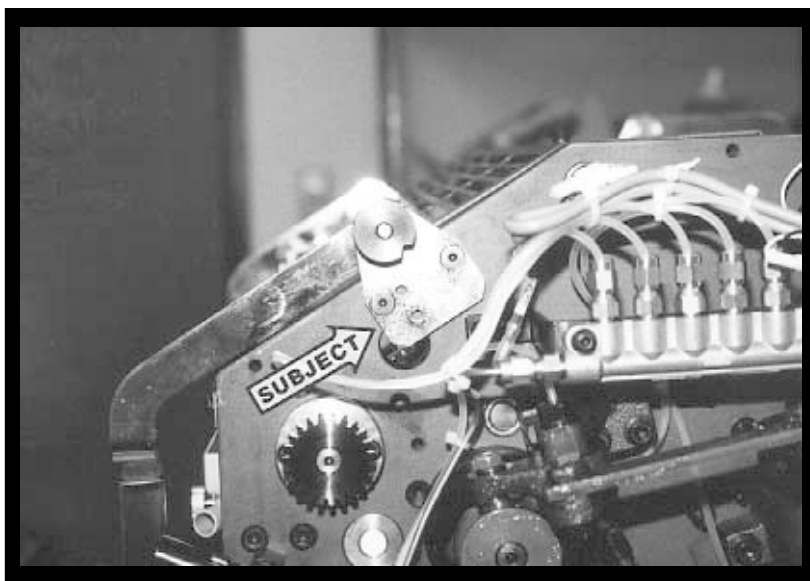
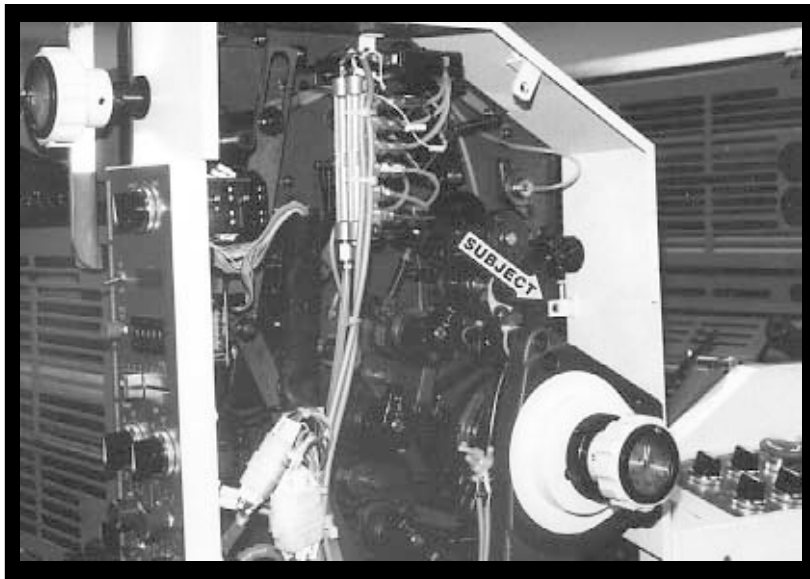
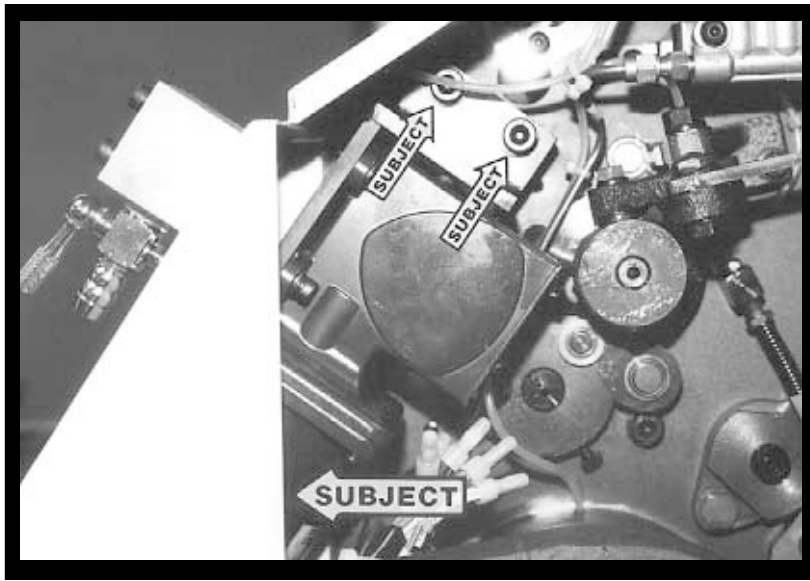

DISASSEMBLY

1

THE FOLLOWING INSTRUCTIONS WILL APPLY TO BOTH PRINTING HEADS UNLESS OTHERWISE INDICATED.

Remove NOPS upper side cover. Remove dampener pan roller motor by removing the two cap screws in the black bracket (indicated by small subject arrows). If motor is not equipped with a detachable wiring harness, all wire leads must be cut and secured with provided wire nuts. With damp motor removed, you can now remove inner NOPS cover (indicated by large subject arrow).

2

Drop OPS cover door down to access bolts for cover and remove (subject arrow).

3

Remove the sheet metal guards covering the dampener. On the #2 printing unit, the easiest method is to remove the microswitch and unbolt the hinge plates (subject arrow) from both sides of the press.

7

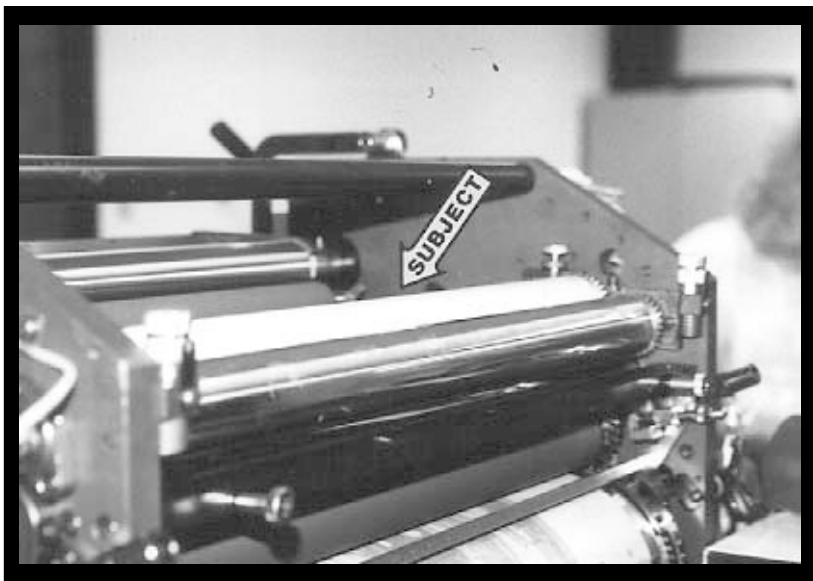
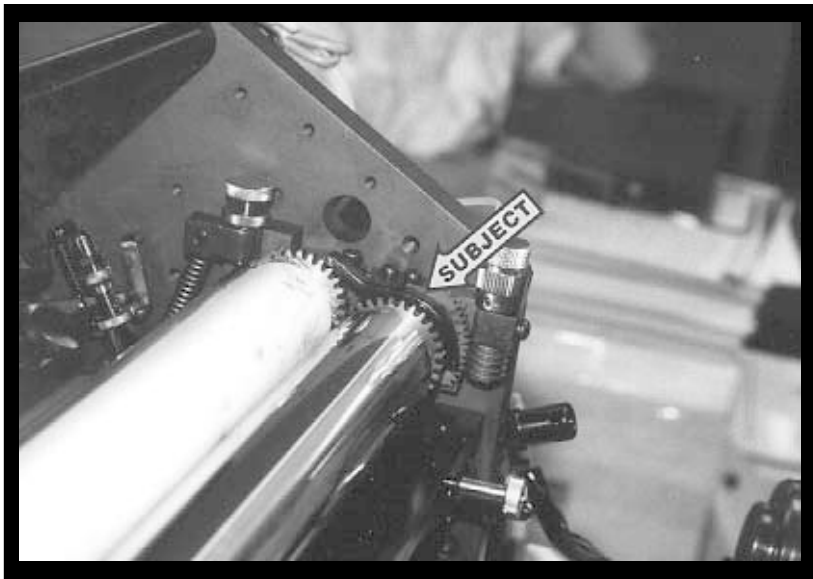
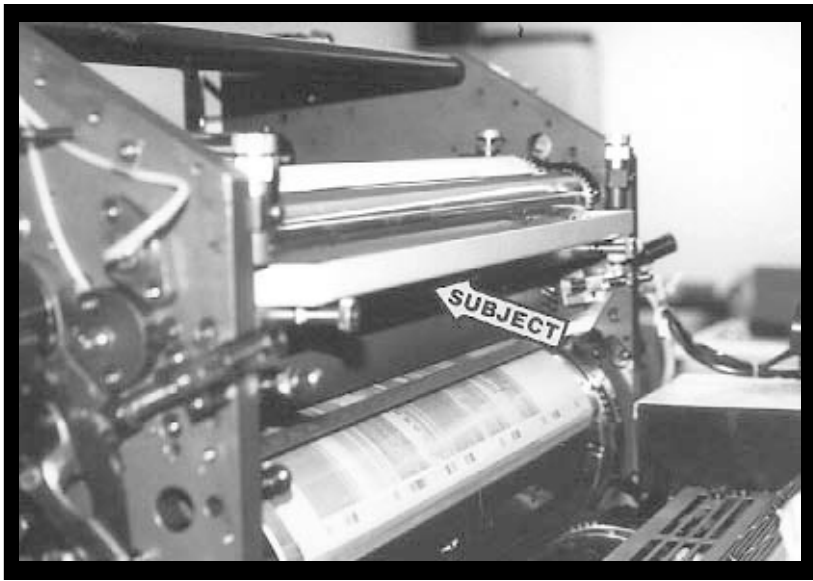

DISASSEMBLY

4

Remove water pan (subject arrow).

5

Remove gear guard over dampener gears (subject arrow).

6

Remove dampener metering roller (subject arrow) by removing retainers at OPS and NOPS.

9

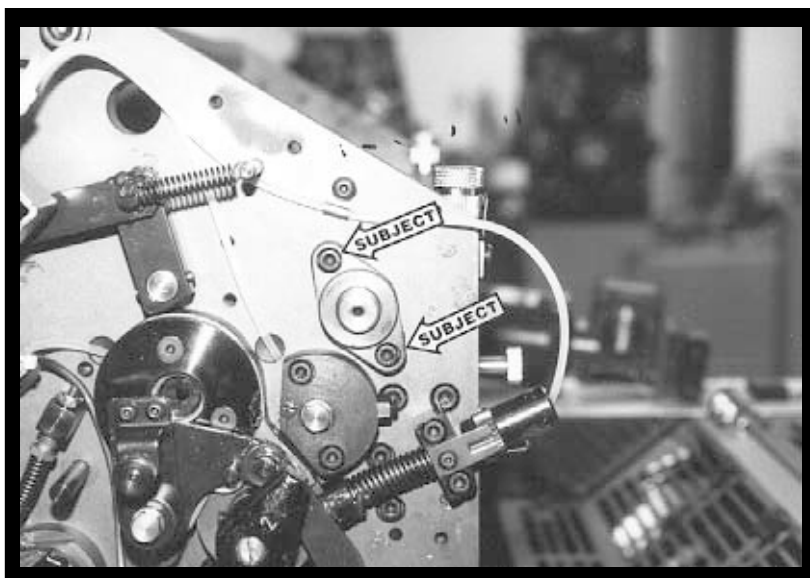
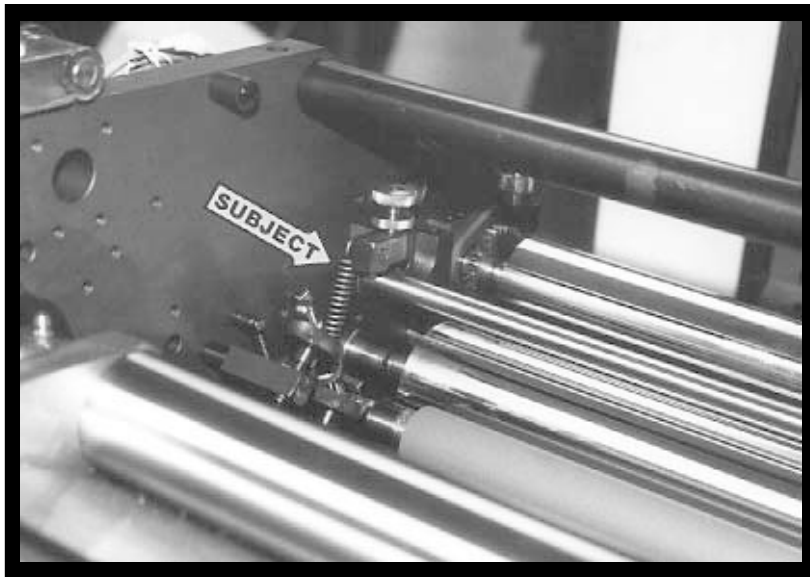
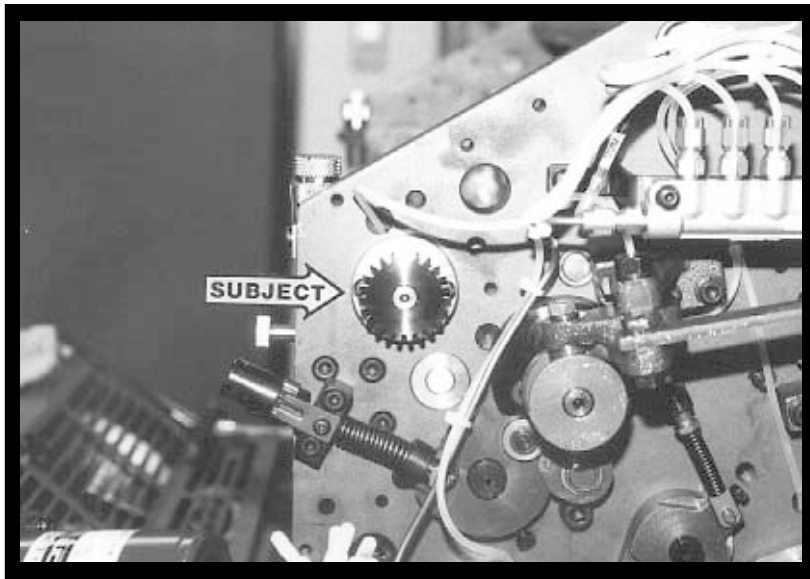

DISASSEMBLY

7

Remove gear on end of pan roller shaft at NOPS (subject arrow) by driving out taper pin and removing set screw.

8

Remove extension spring (subject arrow) from the front of dampener roller mounting blocks.

9

Remove snap ring (not pictured) from OPS pan roller bushing. Next, remove cap screws (subject arrow) from outside of bushing and then remove bushing from frame.

11

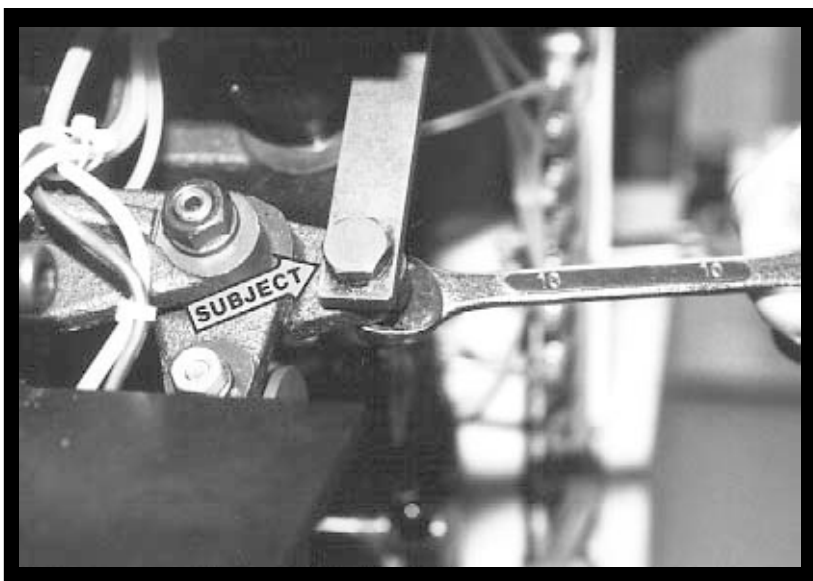
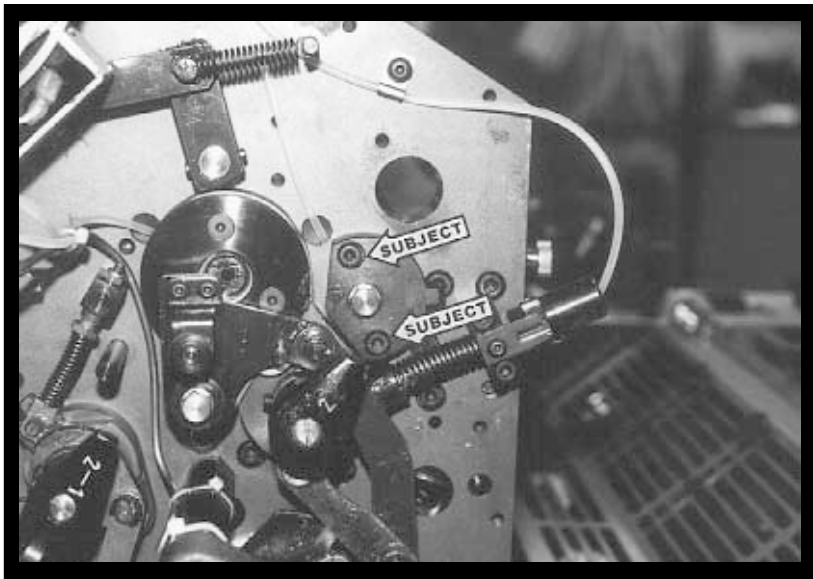

DISASSEMBLY

10

Similar to the previous step, remove the pan roller bushing at NOPS by removing cap screws. Pan roller can then be lifted out of the press (subject arrow).

11

Remove OPS bushing of dampener lockout shaft by removing cap screws (subject arrows) and pull shaft out of the press through OPS side frame.

12

At NOPS, remove shoulder bolt (subject arrow) on oscillator connecting link.

13

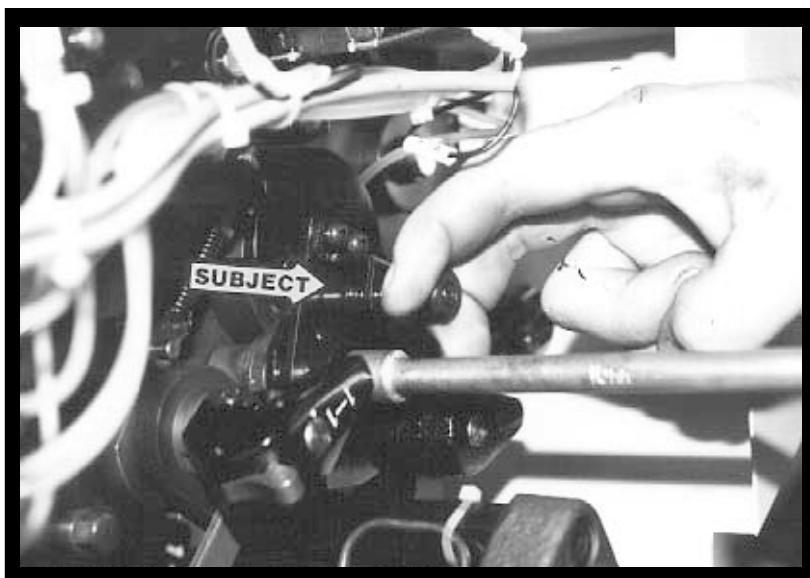
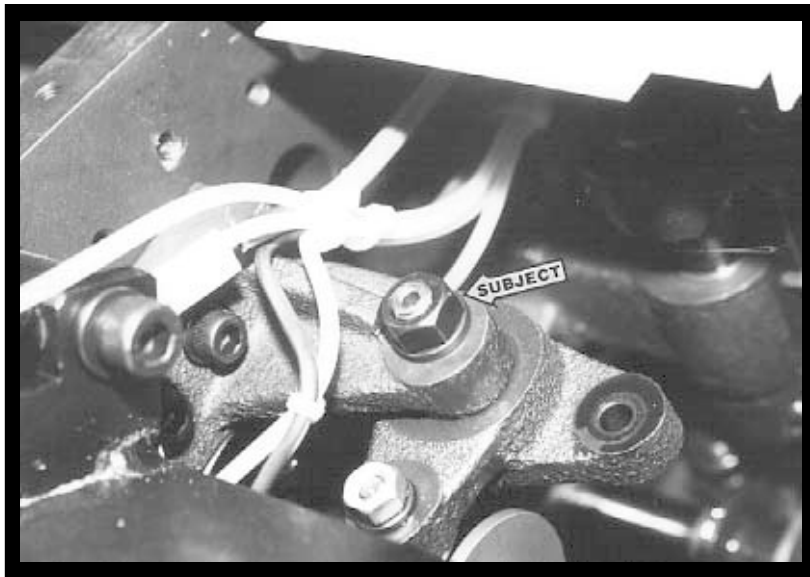
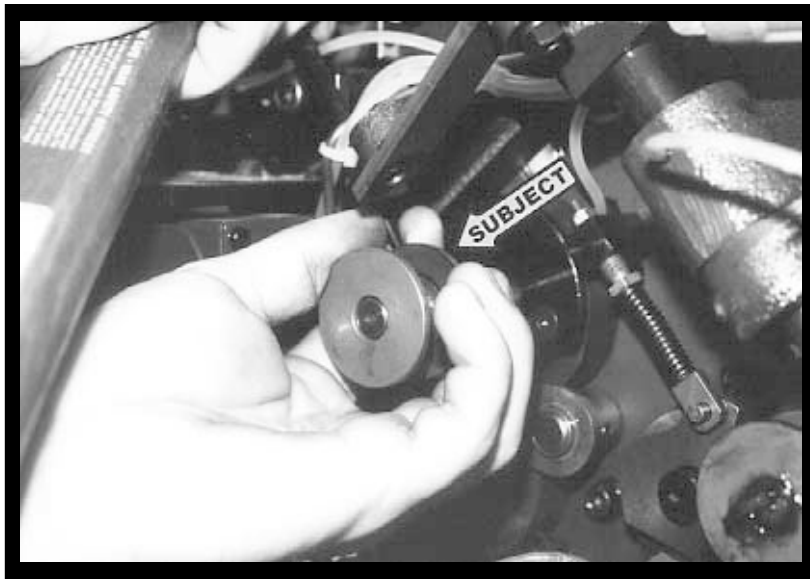

DISASSEMBLY

13

With hammer and punch, remove roll pin which secures spool to end of oscillator shaft (subject arrow). Save roll pin for reinstallation. The spool will be removed in the next step.

14

Remove large nut (subject arrow) from pivot arm. Both pivot arm and spool can now be removed. Save all parts for reinstallation.

15

At OPS, pull pin (subject arrow) on oscillator mechanism and, with press T-wrench, turn hex stud counterclockwise until it stops.

15

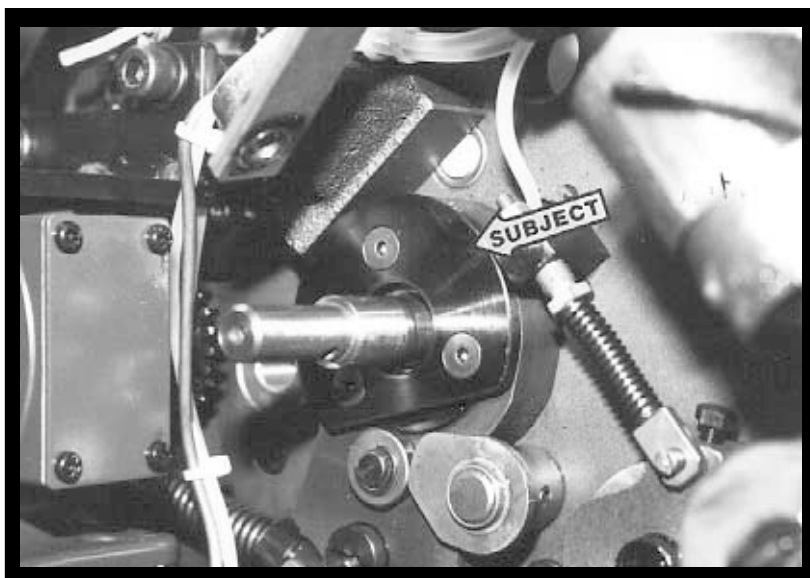
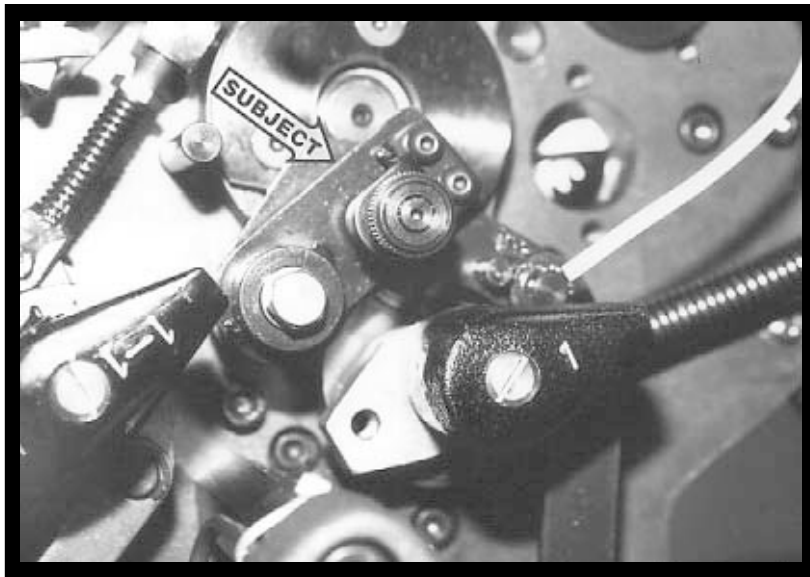
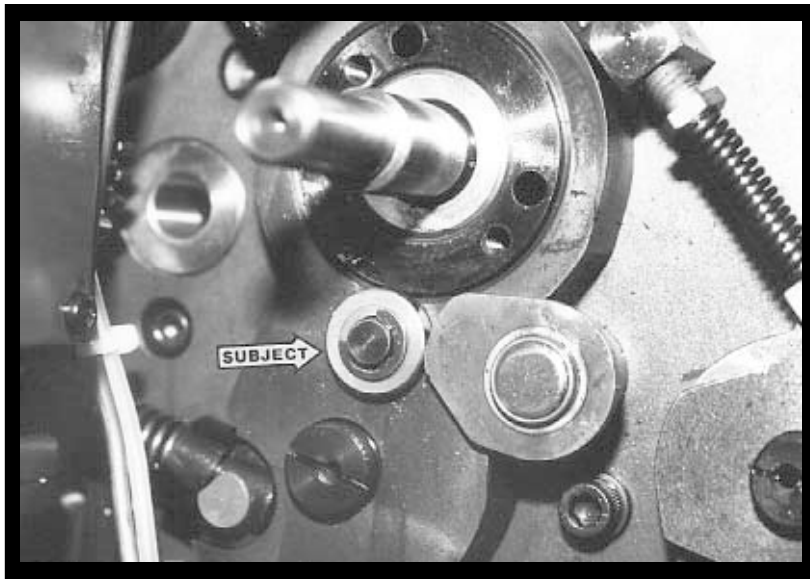

DISASSEMBLY

16

At NOPS, remove E-clip and disc (subject arrow). Save for reinstallation.

17

At OPS, reposition pin from step 15 to its original position (subject arrow).

18

In NOPS oscillator housing, remove three flat-head screws and cover plate (subject arrow).

17

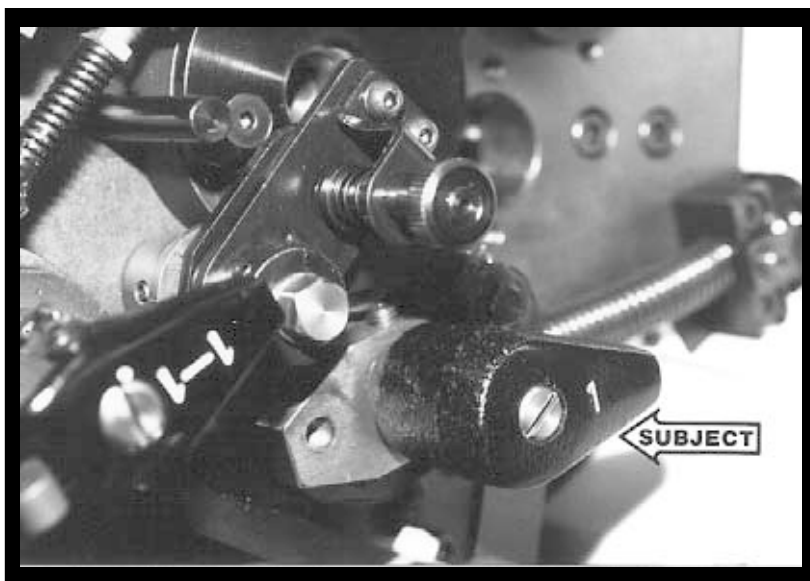
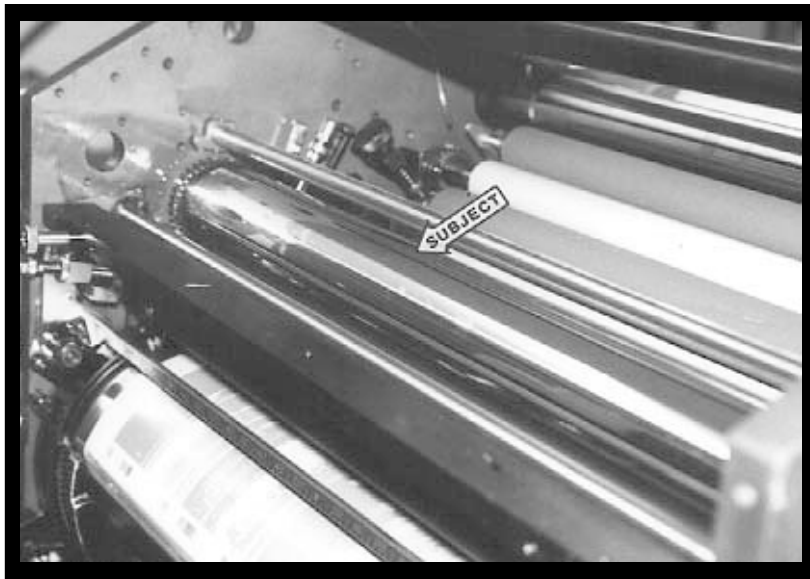
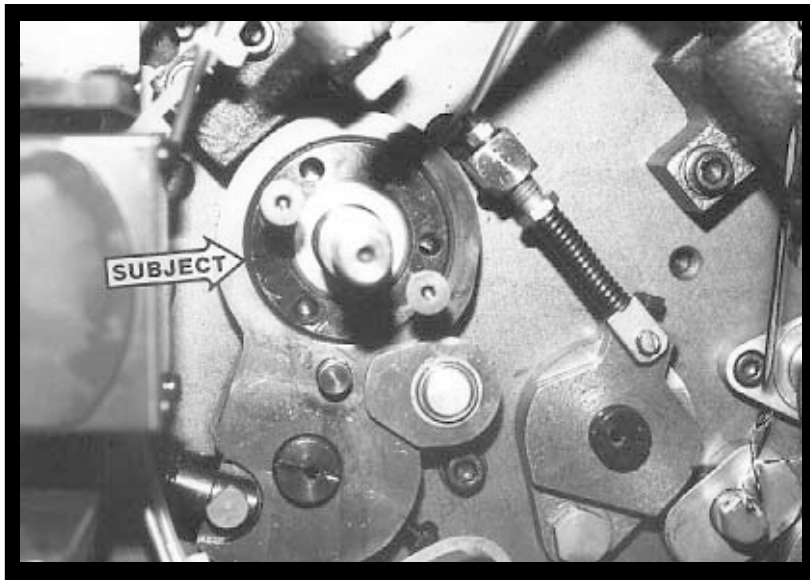

19

Partially thread two of the flat-head screws from the previous step into the housing (subject arrow). Remove housing by grasping the screws and pulling out. Save screws, cover plate, and housing for reinstallation.

20

Oscillator (subject arrow) can now be shifted toward NOPS and lifted out of press. After the roller is removed, remove the gear from the OPS shaft by knocking out roll pin with a hammer and punch. Save gear and pin for reinstallation. (The original oscillator will not be reinstalled).

21

Remove water form roller by disconnecting any linkage attached to the roller shaft (subject arrow) and pulling shaft out of press. Remove snap-ring and helical gear from the NOPS end of the form roller and save for reinstallation.

**YOU ARE NOW READY TO INSTALL CRESTLINE®
DAMPENING SYSTEM**

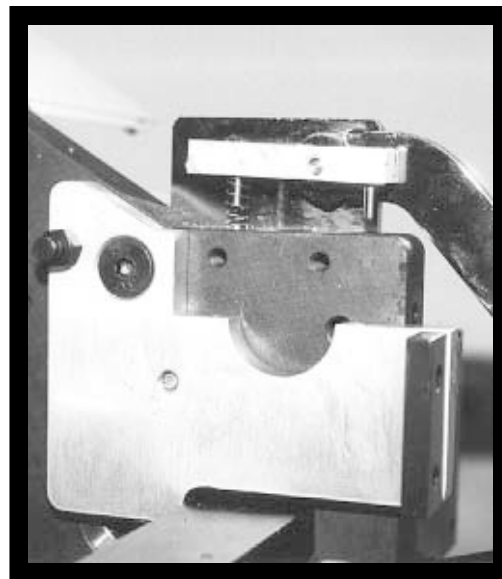
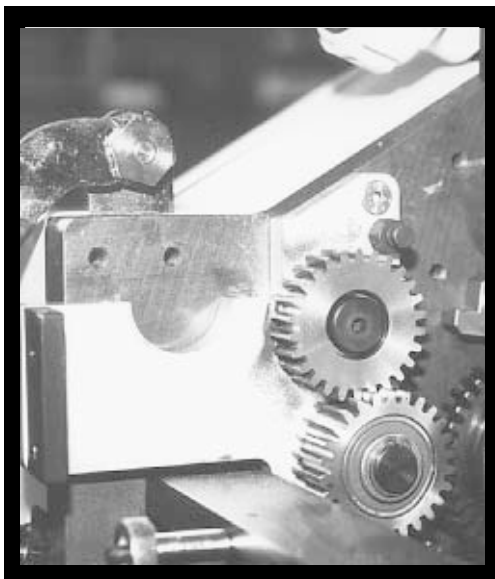
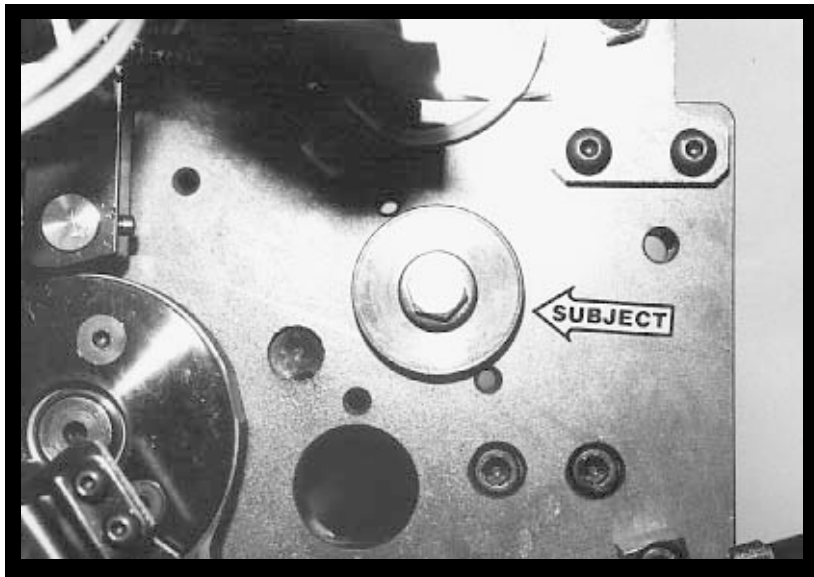

INSTALLATION

1

Install new water form roller and oscillating roller provided by following disassembly steps 12 through 21 in reverse order. These two new parts install exactly like original parts. You will notice the new oscillator no longer has a chrome finish but an ink receptive surface finish. **BE VERY CAREFUL NOT TO SCRATCH OR GOUGE THIS ROLLER WHEN INSTALLING. ALSO, BE SURE ALL OIL LINES ARE PROPERLY RECONNECTED.**

2

At the OPS and NOPS, slip the provided black flanged spools through the press frame (subject arrow). The spools slip through the holes that originally held the pan roller bushings.

3

Remove bearing caps from the dampener mounting plates, noting that each plate and cap are stamped with a matching number. Be sure to properly match-up the caps when reinstalling. On the 1P printing unit (nearest the feeder), bolt on the dampener mounting plates as shown. The plate with the gears goes to the OPS, and the gears mesh with the oscillator gear. Each plate is secured by a long bolt and washer going through the spools installed in the previous step, and a flat-head screw going through the top of each plate and into the press frame.

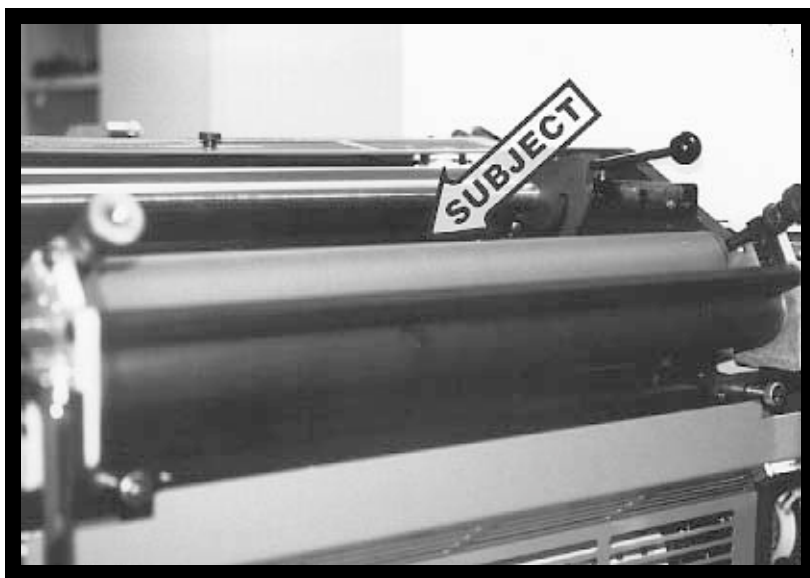
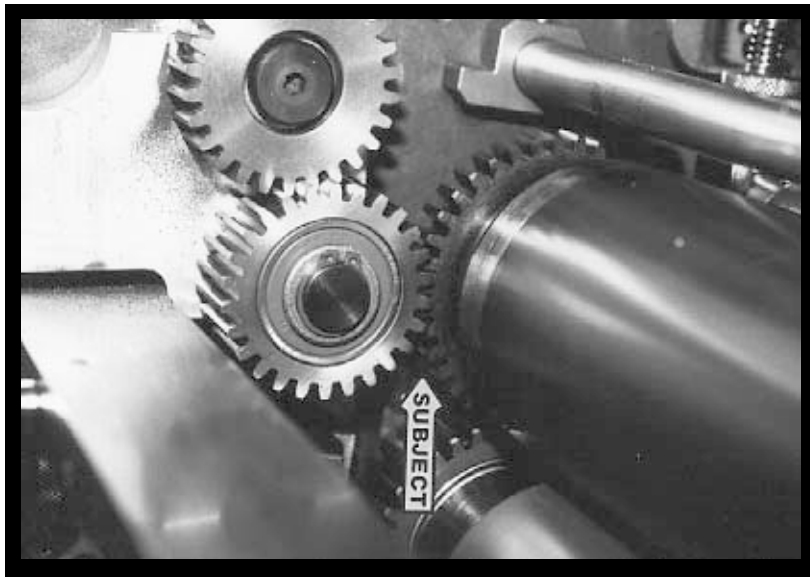
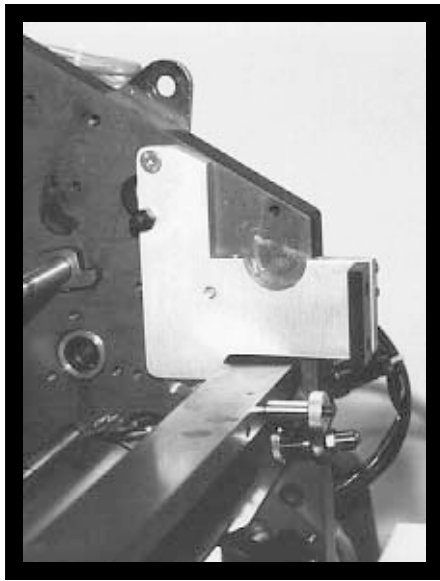

4

Install the 2P printing unit frames in the same manner as the previous step.

5

After installing the plates, check for proper gear mesh between the lower gear on the mounting plate and the oscillator gear. You should have about .003" - .005" backlash between the gears, which means you should be able to very slightly rock the gear on the mounting plate and feel movement against the oscillator gear.

6

Place dampener assembly into the press. The ball bearings at the ends of the pan roller shaft will rest in the bearing cradles of the mounting blocks. Center the dampener within the blocks, replace the bearing caps (remember to match the numbers), and tighten cap screws.

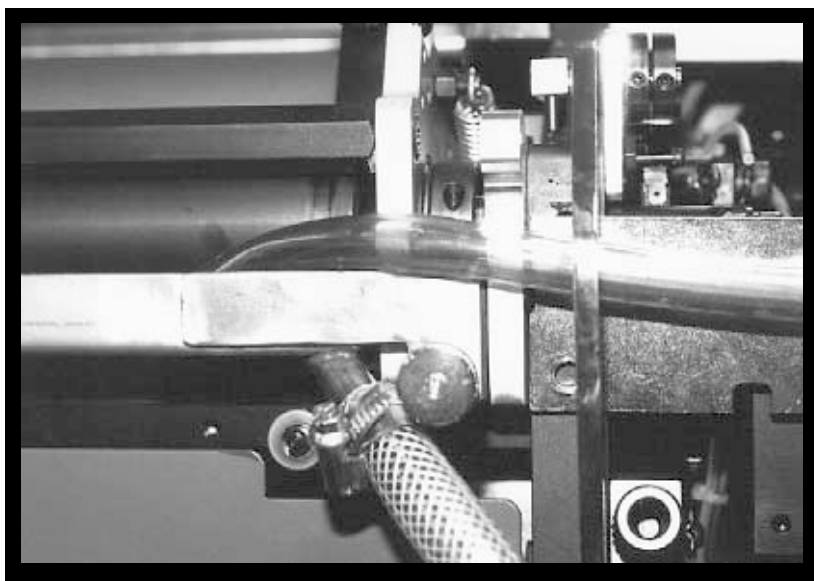
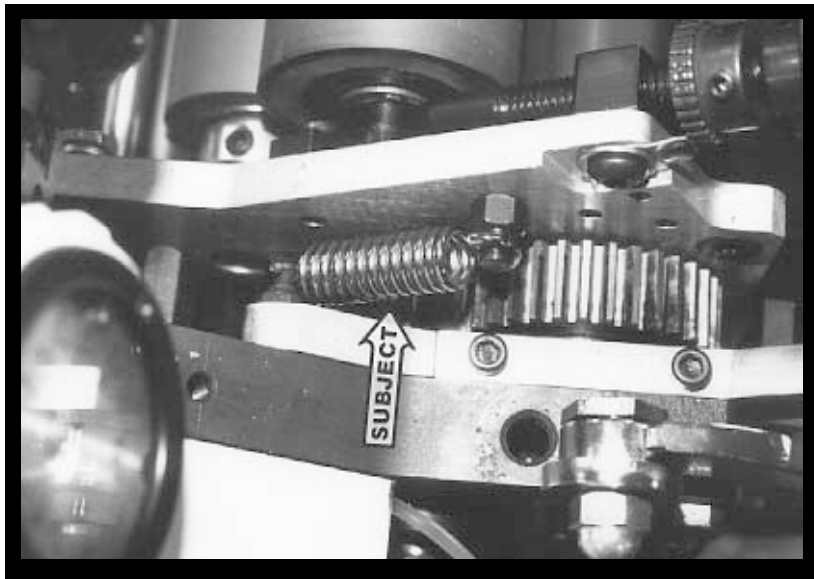
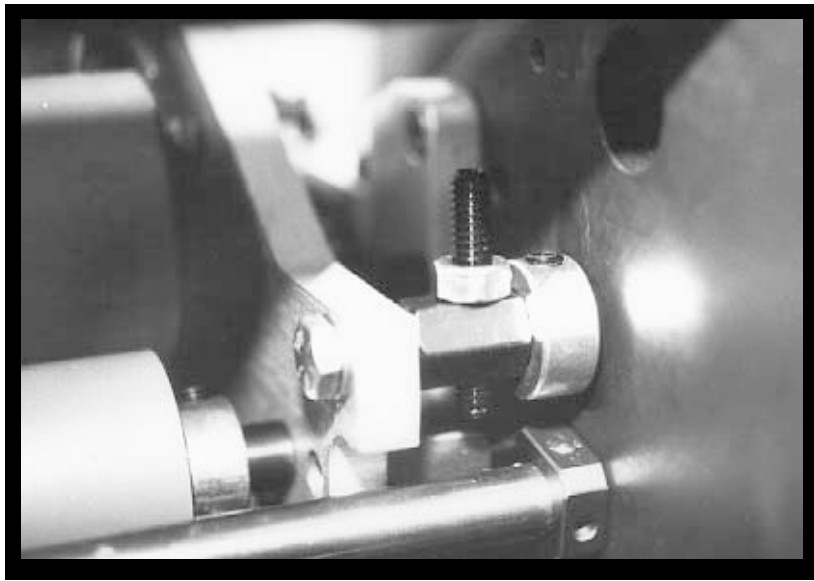

INSTALLATION

7

At the front of the dampener, you will find a set collar on each side attached to the roller adjustment mechanism (subject arrow). Loosen set screw in these collars, push them out against press frame and retighten. Make sure the dampener can pivot freely up and down without binding.

8

Attach extension spring (subject arrow) between studs on dampener frame and mounting frame at OPS and NOPS.

9

Attach and center water pan as shown. Connect circulator drain hose to drain pipe on new pan with the original hose clamp. The filler pipe/hose will attach to the inside of the water pan just like the original, as well as the brass weir for the drain hole. Be sure to use the new weir as the original one is too tall and allows too much fountain solution into the pan.

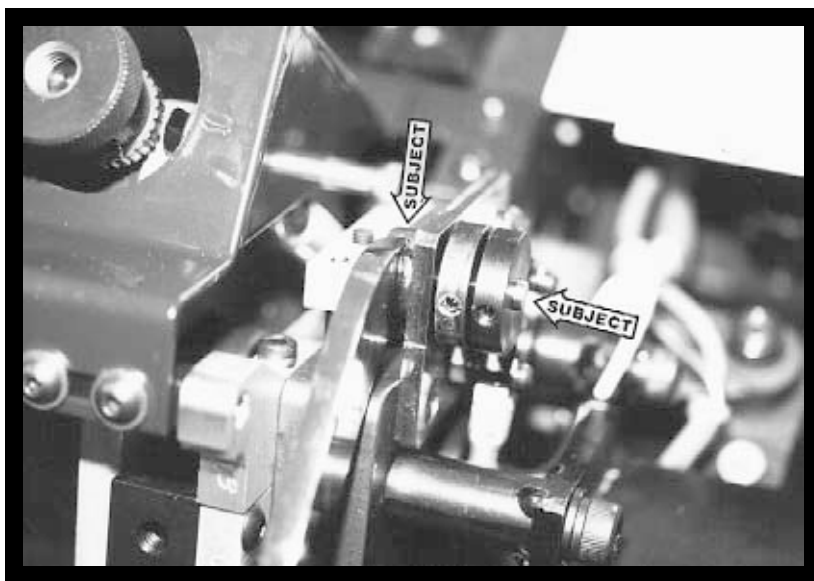
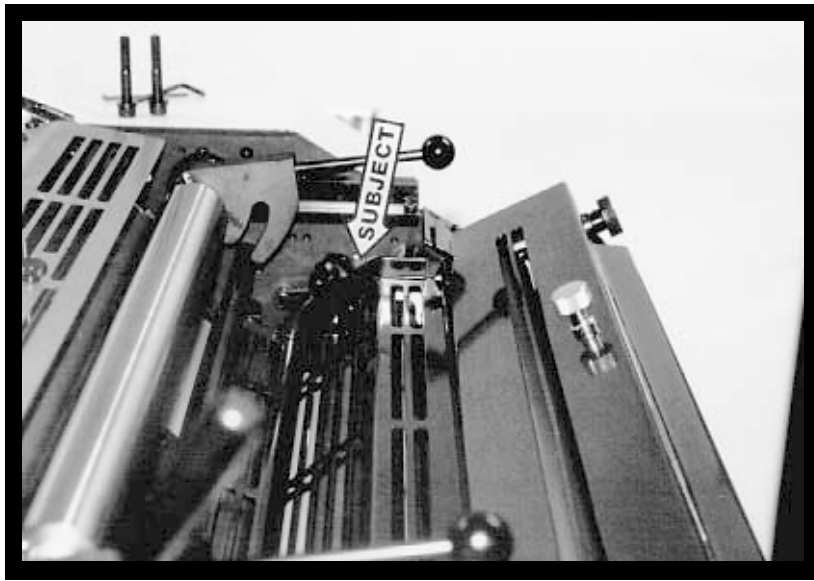

10

THE FOLLOWING STEPS ARE FOR INSTALLING THE NEW SAFETY COVERS

On the 1P unit, replace the fixed guard under the ink fountain with the new one provided (subject arrow). It bolts into the same holes as the original.

11

On the 1P unit dampener guard, loosen the bolts in the pivot blocks (subject arrows) and push the blocks inward. Drop the guard over the dampener, push blocks outward and through holes in bearing cap on mounting plate. Center the guard and tighten bolts in pivot blocks.

12

On the 1P unit, loosen set screw in NOPS hinge arm (left subject arrow) and on microswitch trip cam. Remove hinge pin and replace it with the new double pin provided (right subject arrow). With larger section of new pin flush with the inside of the hinge arm, tighten set screw in hinge arm. Slip on the original microswitch trip cam along with the additional one provided (the cams are identical). Do not tighten the screws in the cams at this time.

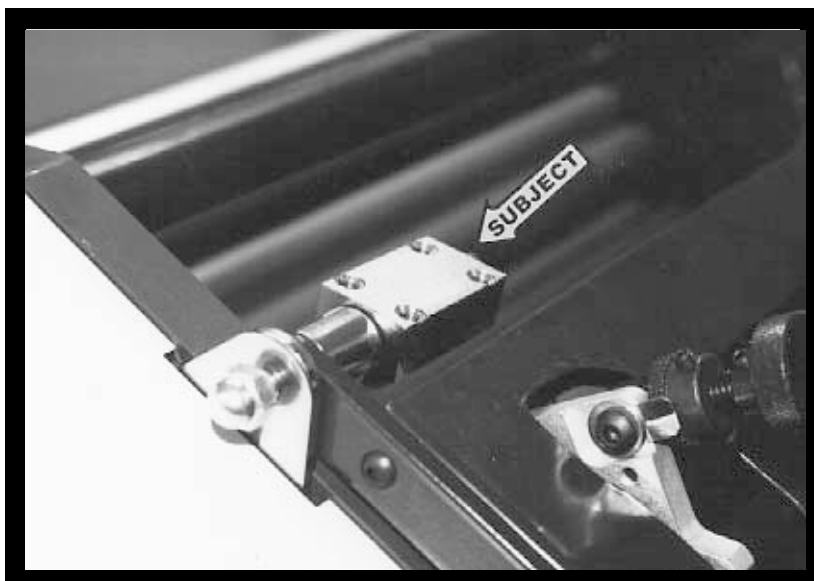
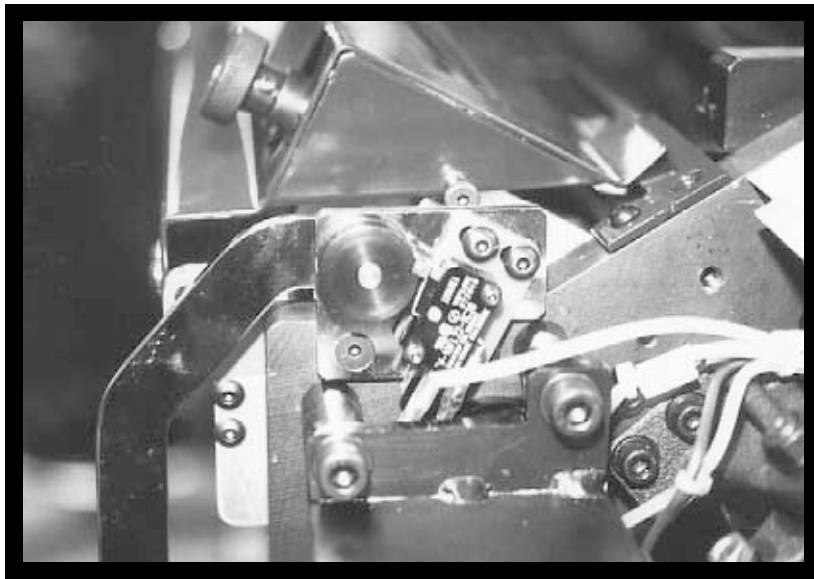
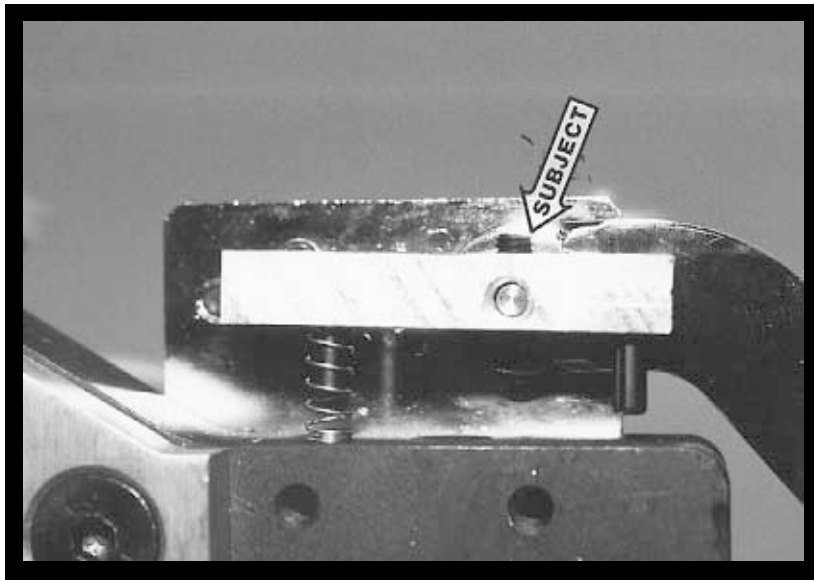

13

On the new hinge pin installed in the previous step, slip the provided spring-loaded block as shown. The spring will be toward the delivery end of the press. With the plate guard in the closed position, tighten set screw (subject arrow). Make sure the block is pushed as far outward as it will go. (Note: The photo shows dampener and previously installed guards removed).

14

With both the new dampener guard and plate cylinder guard closed, position the cams so that the roller on the microswitch trip arm rests in the detents. The inner cam will be activated by the plate cylinder guard. The outer cam will be activated by the spring loaded block when the dampener guard is raised. Be sure the cams are attached to the appropriate section of the double hinge pin. Open and close both guards and readjust cams as necessary.

15

On the 2P unit, remove existing plate cylinder guard from the original hinge arms. Attach this guard to the new hinge arms provided. Place this assembly onto the press exactly like the original (refer to disassembly step 3 if necessary). Be sure to reinstall the microswitch at NOPS. Turn chrome hinge blocks (subject arrow) so that the tapped holes face up.

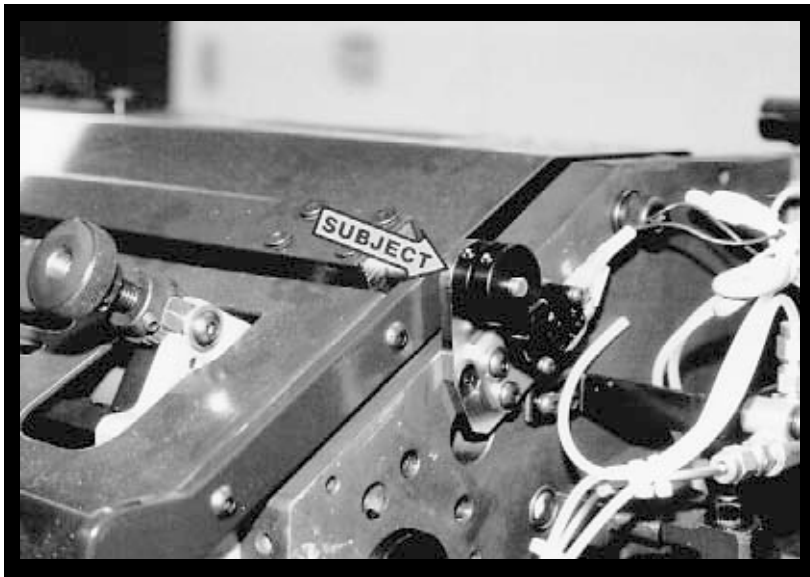
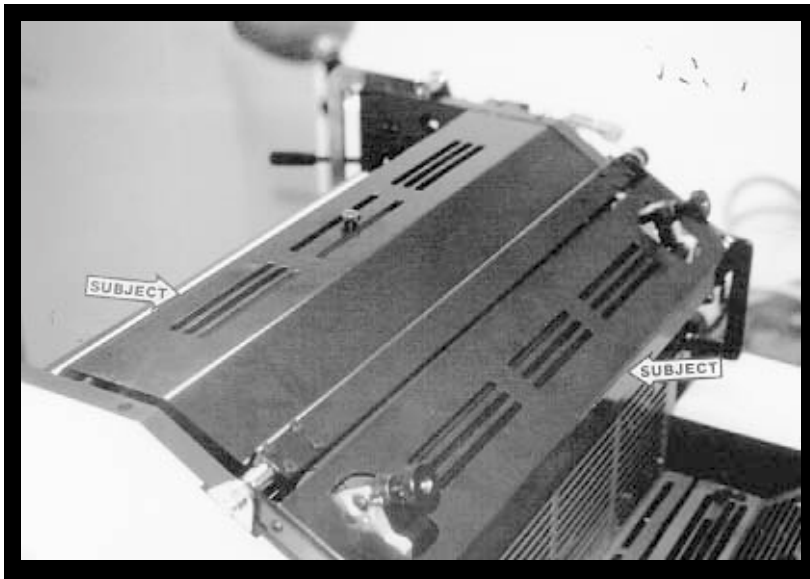

16

Attach dampener cover (right subject arrow) to hinge arms with the provided screws. Attach new inker cover (left subject arrow) to the chrome hinge blocks with the provided screws.

17

With both the 2P unit guards closed, position the two trip cams on the NOPS (subject arrow) so that the roller on the microswitch trip arm rests in the detents. Open and close the guards and adjust cams as necessary. When finished, replace all press side covers.

YOU ARE NOW READY TO MAKE FINAL ADJUSTMENTS

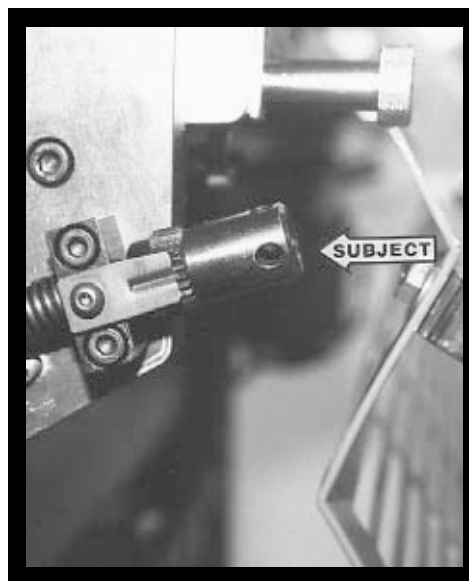
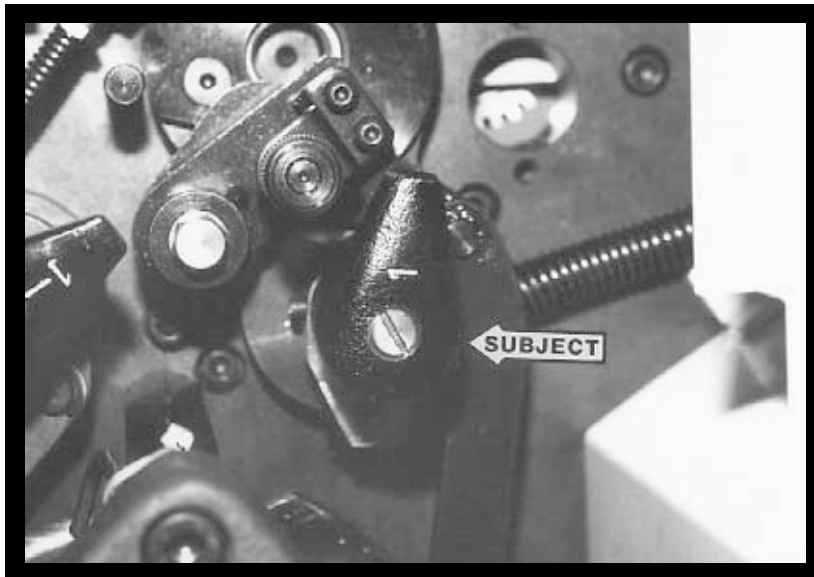

FINAL ADJUSTMENTS

1

INKING UP THE DAMPENER

Make sure Crestline® metering roller is in place and turn thumb screws on top of dampener down until you can feel some pressure being applied to the metering roller. Turn the dampener form roller switches for both printing units to the OFF position. Turn dampening switches to ON position. Engage bridge roller to the dampener oscillating roller. Apply ink to the ink rollers or place ink in the fountain. Turn on press and run slowly to distribute ink to the inker and dampener (dampener will pick up ink from the bridge roller). While the press is running, check to see that the Crestline® is running smoothly with no apparent noises. Stop the press a couple of times during the initial run to apply grease to the dampener gears. Once the press is sufficiently inked-up, stop the press.

2

WATER FORM TO WATER OSCILLATOR PRESSURE

The first Crestline® adjustment to check is the oscillator to form pressure. After the press sits still for about 30 seconds, you should be able to jog the press forward and see a stripe (bead line) on the form or oscillating roller. This stripe should be 4 mm (5/32"). To adjust, locate the outer set screw on the side of the water form shaft (subject arrow). Loosen this set screw and, with a standard screw driver, turn the slotted screw on the end of the form roller shaft. Turning the slotted screw clockwise will increase this stripe, counterclockwise will decrease it.

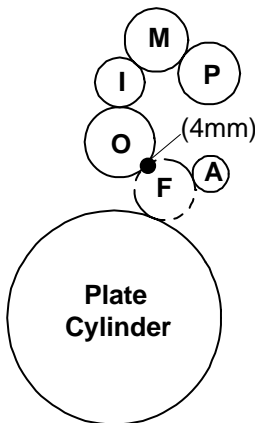

3

WATER FORM TO PRINTING PLATE PRESSURE

The second stripe to check is water form to plate. With a metal plate mounted to the cylinder, take T-wrench supplied with press and place over hex stud underneath registration adjustment knob (subject arrow, left picture). Turn clockwise to the #1 position and then back to zero. Jog the press backwards and observe the stripe left on the plate. This stripe should be 4 mm (5/32"). It is adjusted identical to the original dampener form by turning the indexed knobs at each side of printing head (subject arrow, right picture). Turning the knobs down decreases the stripe and vice-versa.

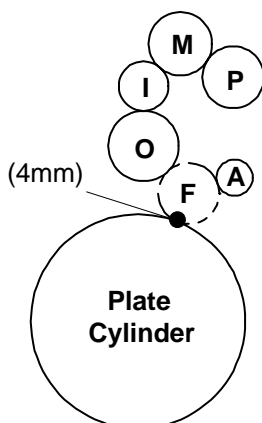

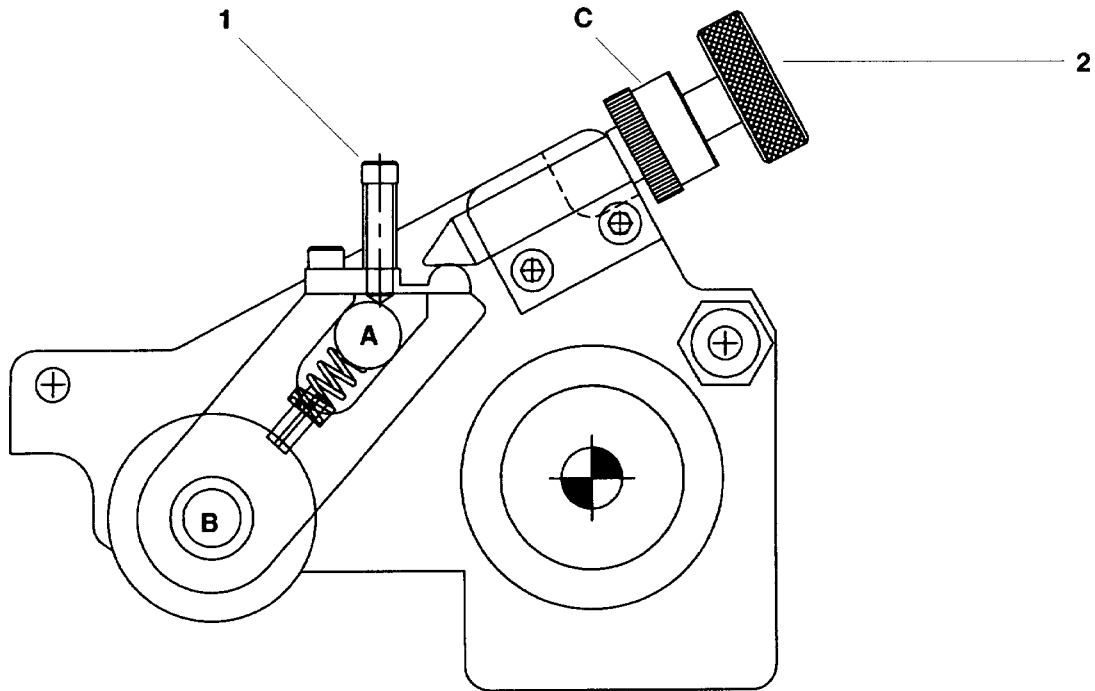
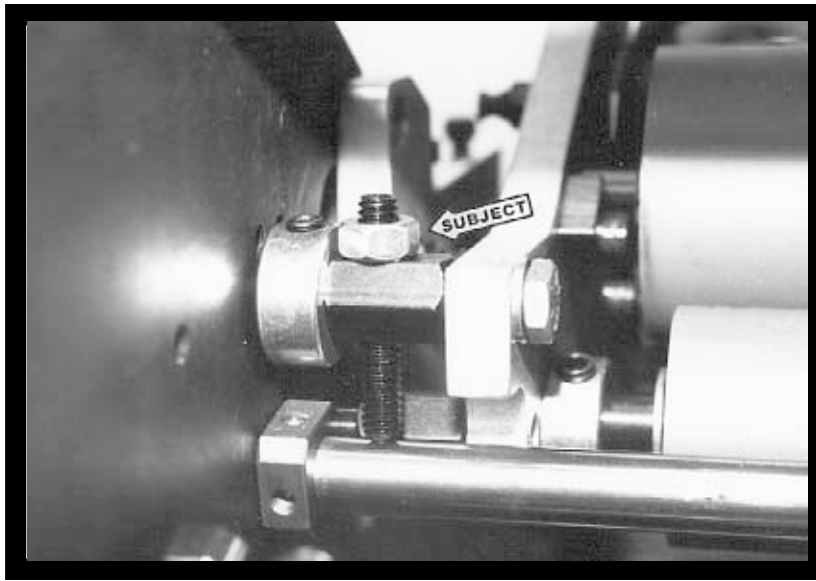

FINAL ADJUSTMENTS

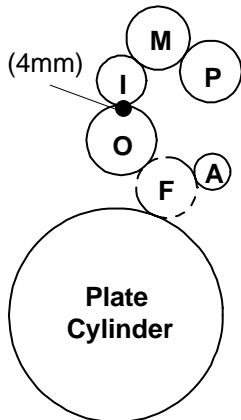

4

DAMPENER INTERMEDIATE TO OSCILLATOR PRESSURE

The next stripe to check is the dampener intermediate roller to dampener oscillating roller. The dampener intermediate roller is the forward-most roller in the upper dampener assembly and sits on top of oscillator. The stripe can be seen by jogging the press forward and observing the bead line left on the intermediate roller. This stripe should also be 4 mm (5/32"). To adjust, loosen lock nut on roller adjustment mechanism (subject arrow) and turn screw down to decrease the stripe, or up to increase. Retighten lock nut when finished. (Remember that the dampening knobs must be in the ON position for these two rollers to be in contact).

5

DAMPENER METERING TO INTERMEDIATE & PAN

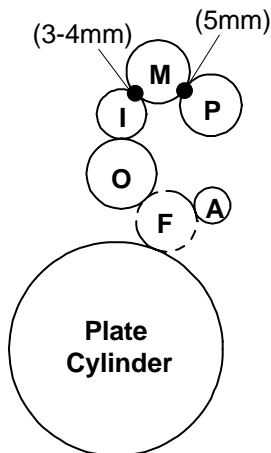

1. Turn screw (1) clockwise. This **increases** the pressure on the metering roller shaft (A) and creates more pressure between the metering & intermediate rollers. Check the pressure by rotating the press **backwards** with the water form roller engaged to the plate. The stripe should be 1/8" - 5/32" (3mm - 4mm).
2. Turn knob (2) clockwise. This increases the pressure on the hanger bracket, creating more pressure between the metering & pan rollers. Check the pressure by rotating the press forwards. The pressure should be 3/16" (5mm). Lock the pressure in place by turning the ratchet gear (c) clockwise until it stops. Tighten set screws in the ratchet gear to retain pressure setting.

6

CIRCULATOR FLOW

The last setting to make is the circulator flow into the water pan. Fill the circulator with fountain solution. Initially, completely shut off the filler valves, turn circulator on, and slowly open until you can see fountain solution flowing into the pan. Generally speaking, you do not need much more than a trickle to maintain good circulation. Too much flow can mean the pan will fill faster than it can drain, and, therefore overflow.

FINAL ADJUSTMENTS

7

You are now ready to print. Return all knobs to the automatic position. Generally speaking, the knobs should be left in this position for normal printing operation. In the automatic mode, the dampener form roller will be off the plate, and the intermediate roller will be off the oscillator when the press is idling. When printing commences, these rollers will drop in the required sequence and the plate will receive water.

The toggle switch that controlled the original dampener motor can be switched to the off position and left there, as this switch no longer has a function.

If you have any questions regarding the function of the control panel knobs and switches, please refer to your Hamada manual.

SIDE FRAME ASSEMBLY-OPS
HAMADA C248

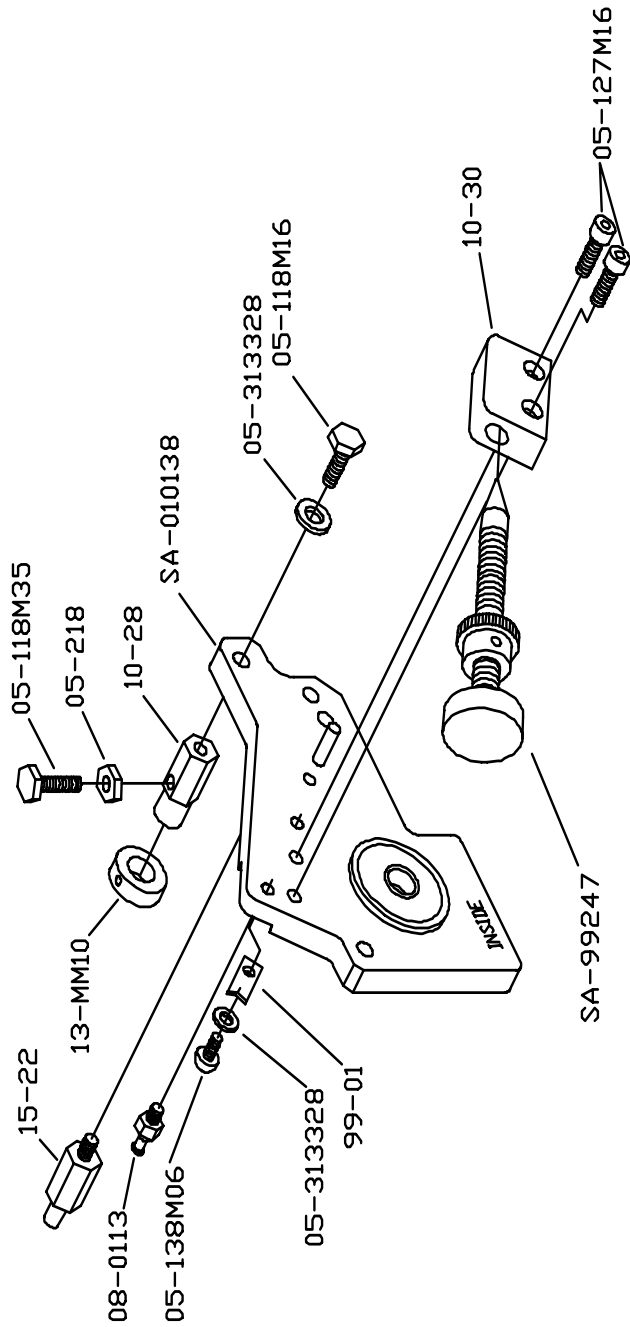

SIDE FRAME ASSEMBLY-NDPS
 HAMADA C248

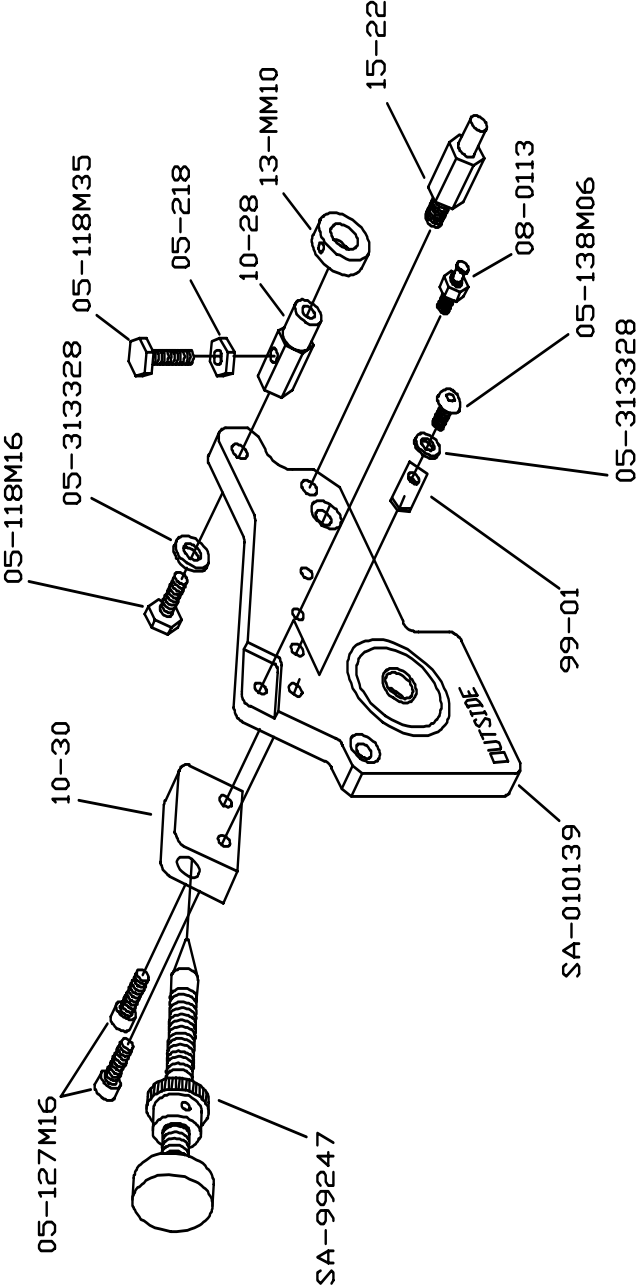

C248C02, 3-10-97

DAMPENER MOUNTING ASSEMBLY 2P-OPS
HAMADA C248

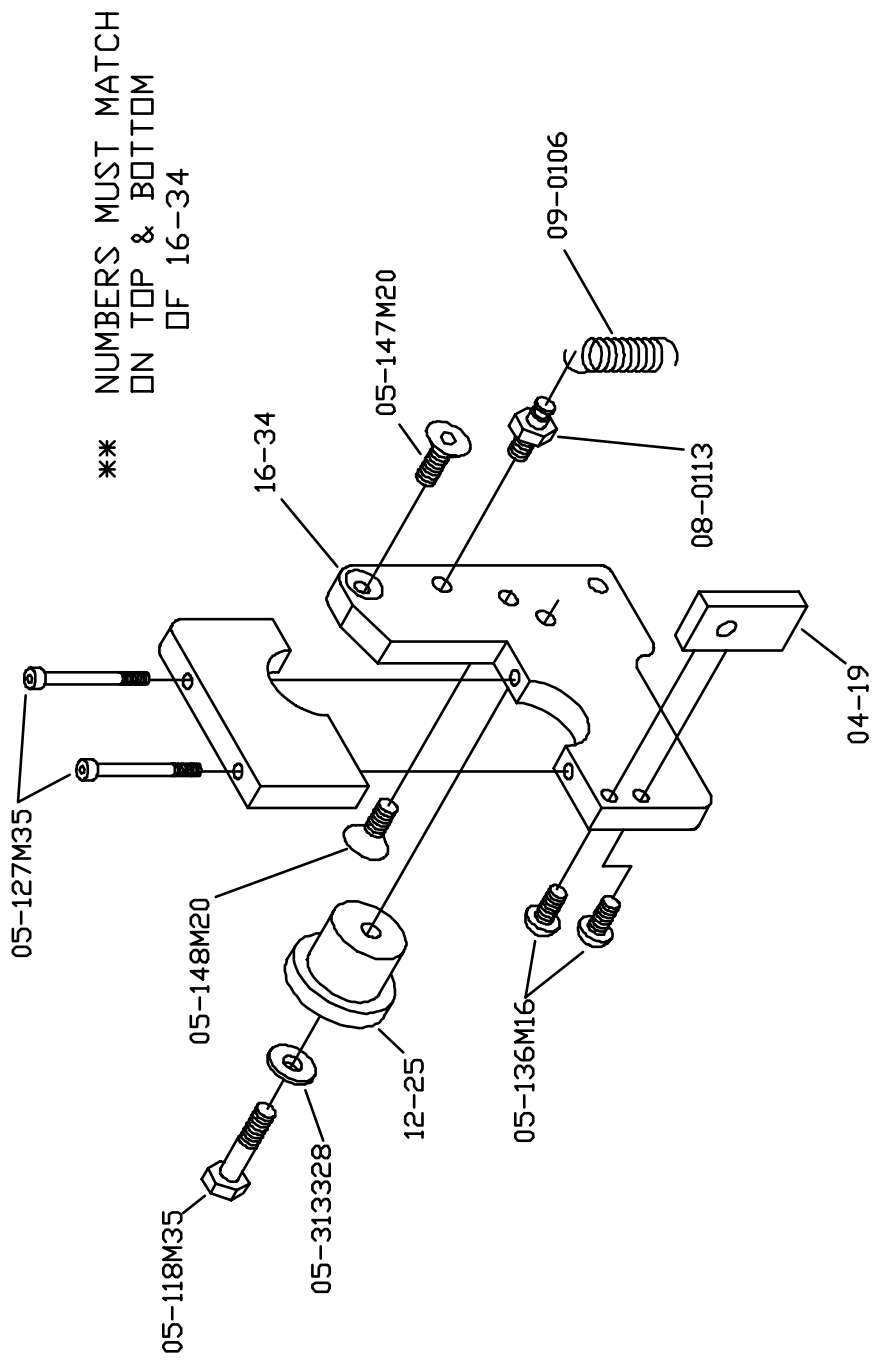

C248C05, 1-9-98

DAMPENER MOUNTING ASSEMBLY, 2P-NOPS
 HAMADA C248

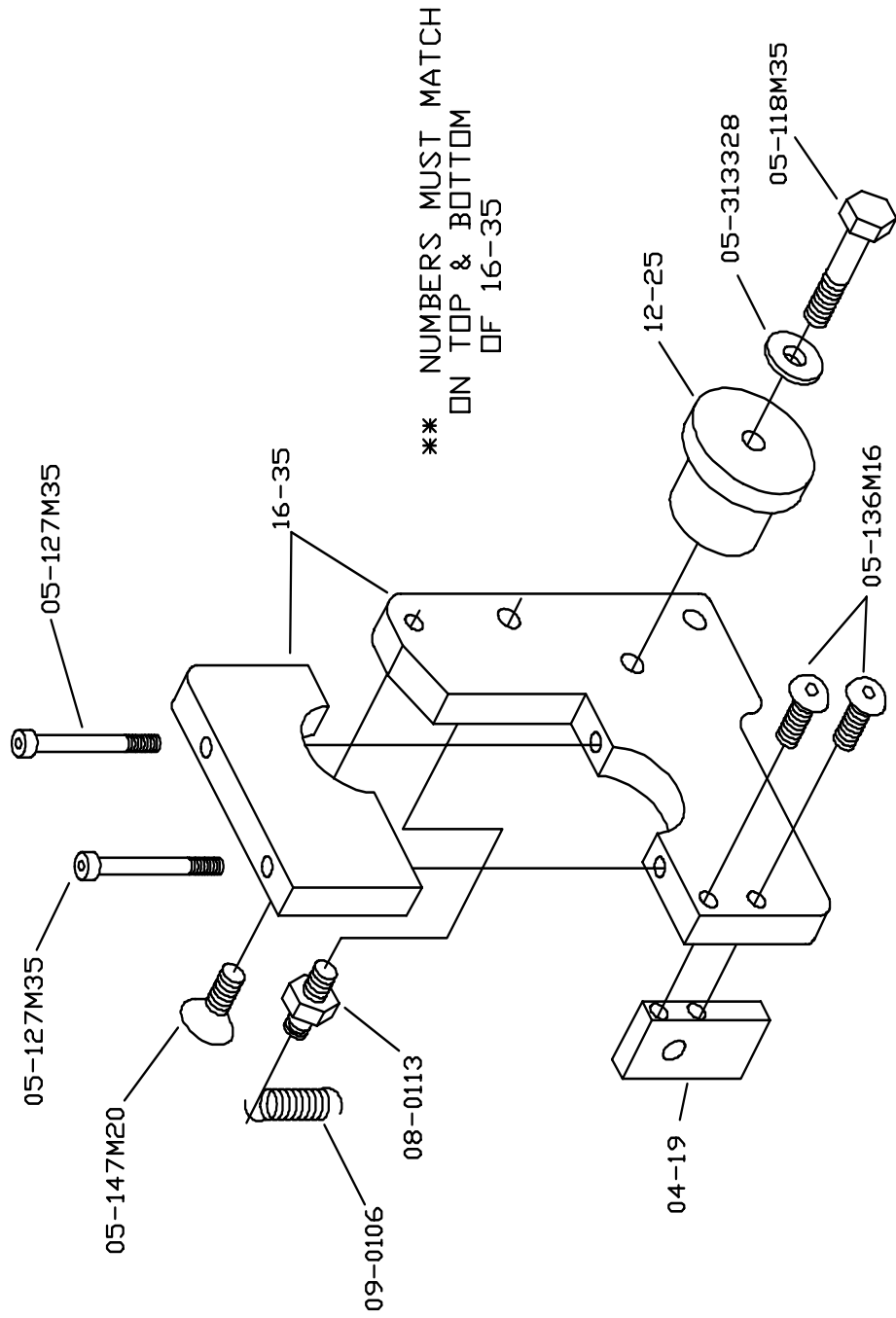

C248C06, 1-9-98

IDLER GEAR ASSEMBLY, 1P
HAMADA C248

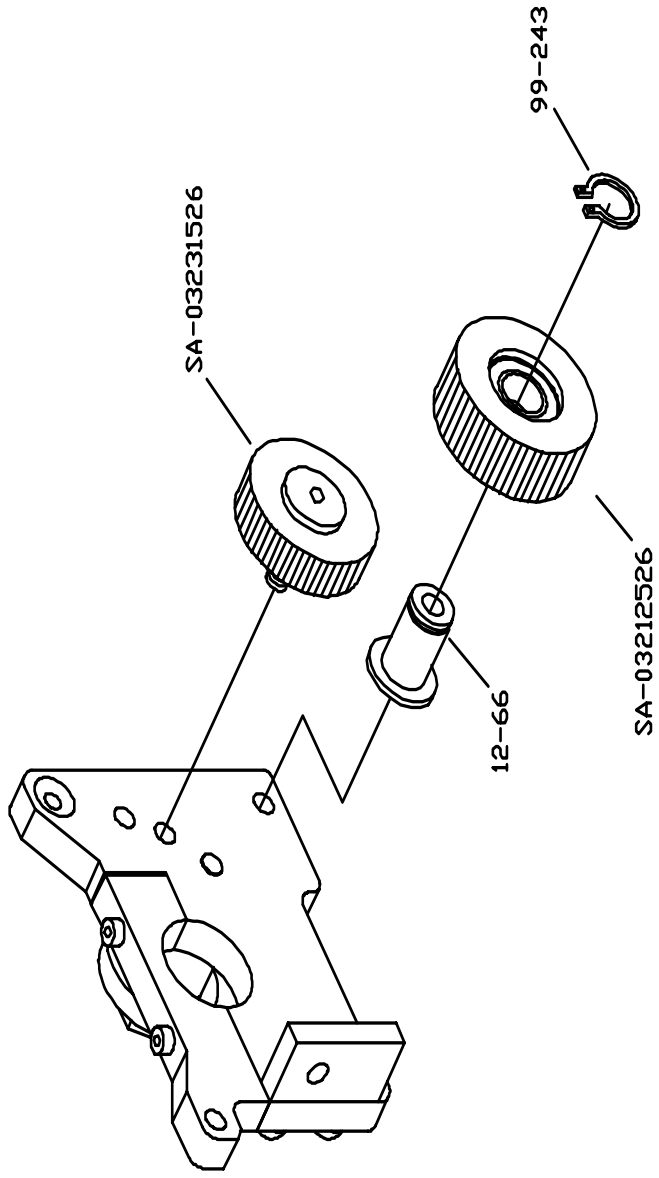

C248C07, 8-5-97

DAMPENER MOUNTING ASSEMBLY, 1P-OPS
 HAMADA C248

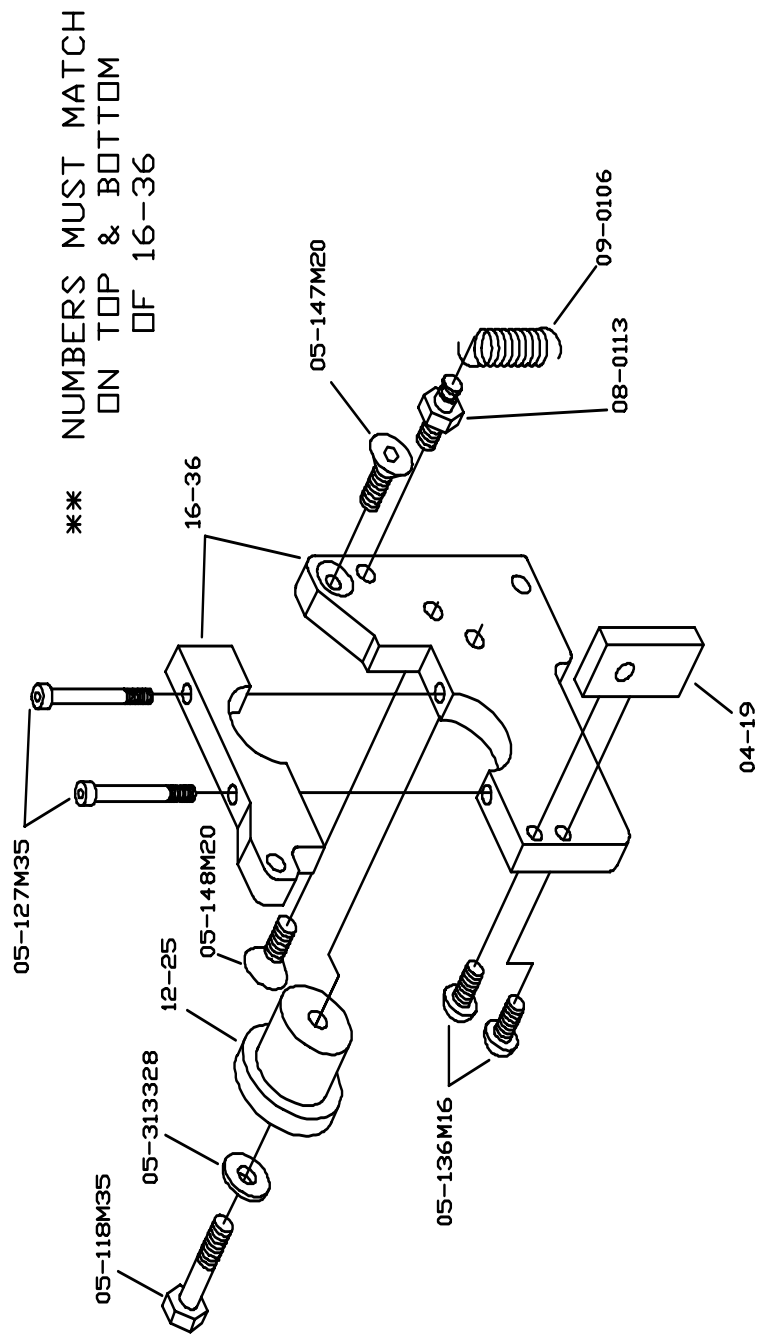

C248C08, 1-9-97

DAMPENER MOUNTING ASSEMBLY 1P-NOPS
HAMADA C248

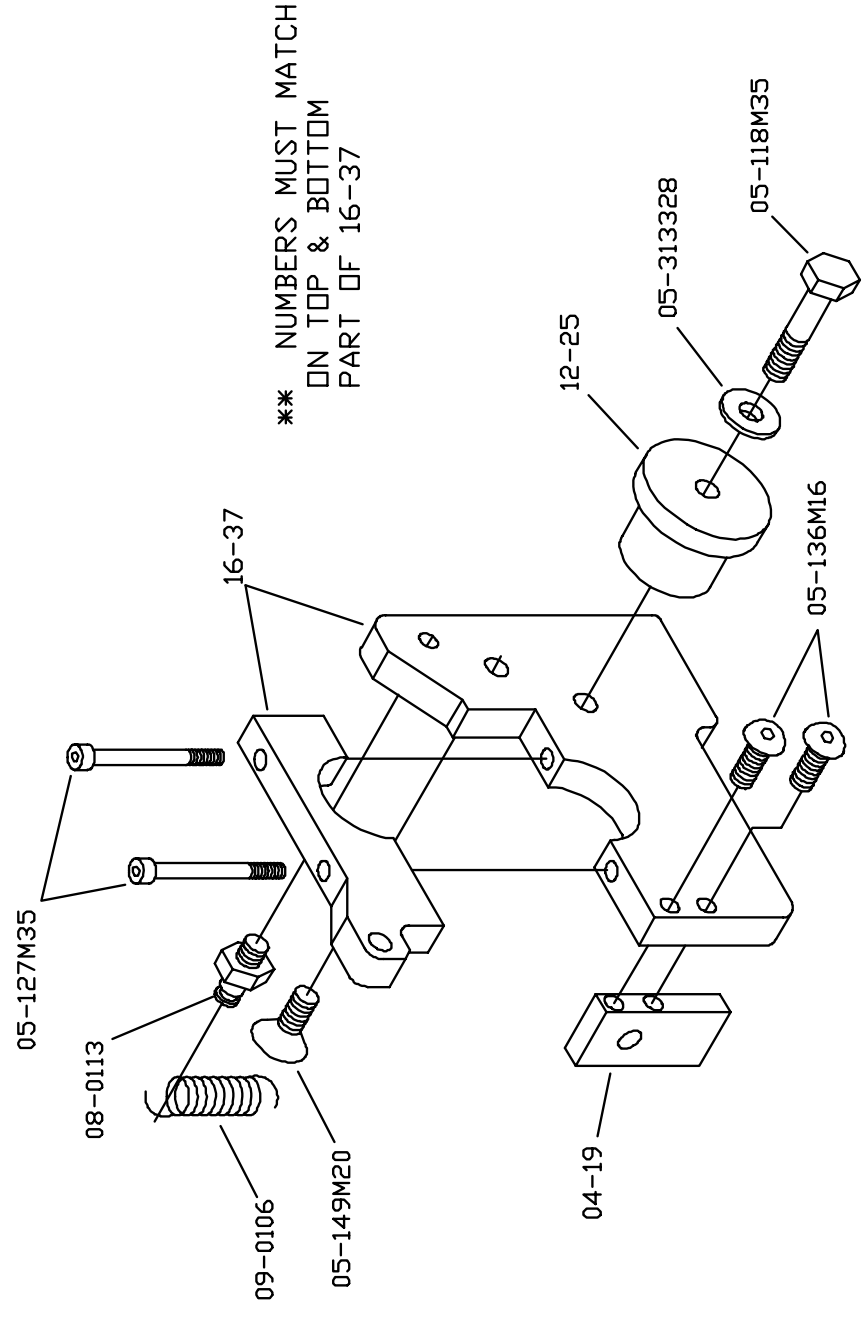

DAMPENER ASSEMBLY
HAMADA C248

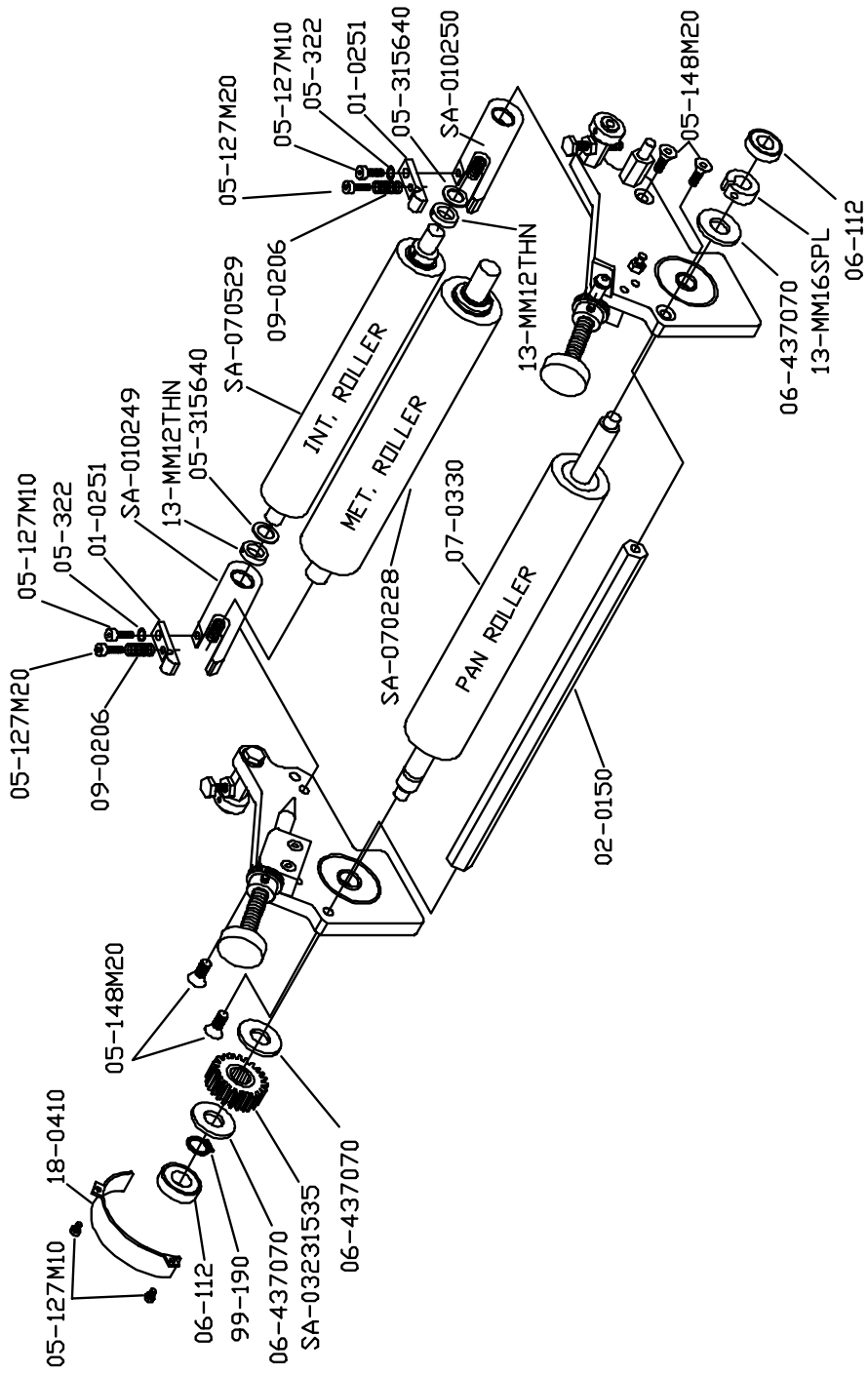

C248C10, 2-12-97

IDLER GEAR ASSEMBLY 2P
HAMADA C248

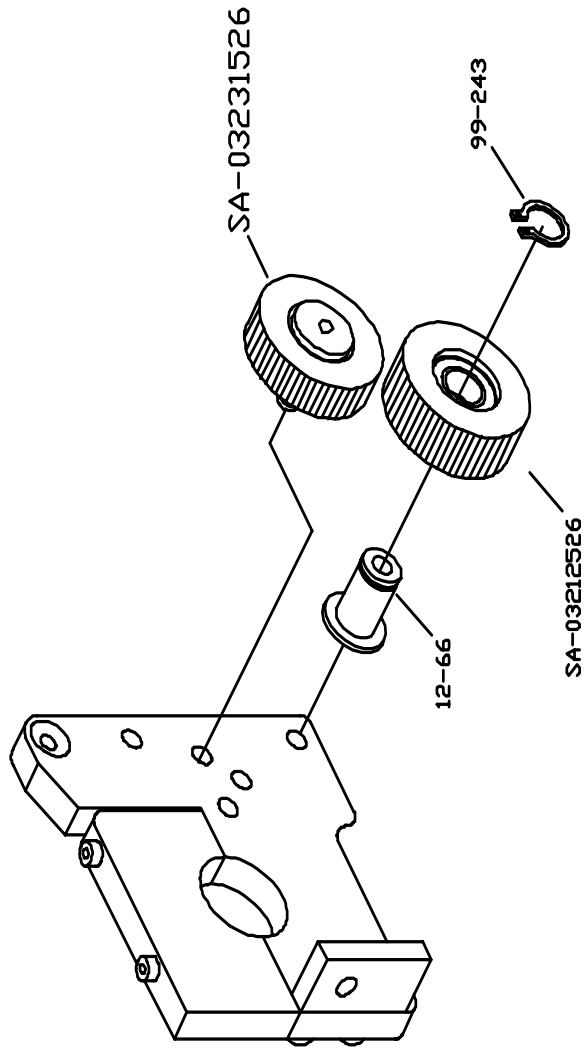

C248C11, 8-5-97

WATER FORM & RIDER ROLLER ASSEMBLIES
HAMADA C248

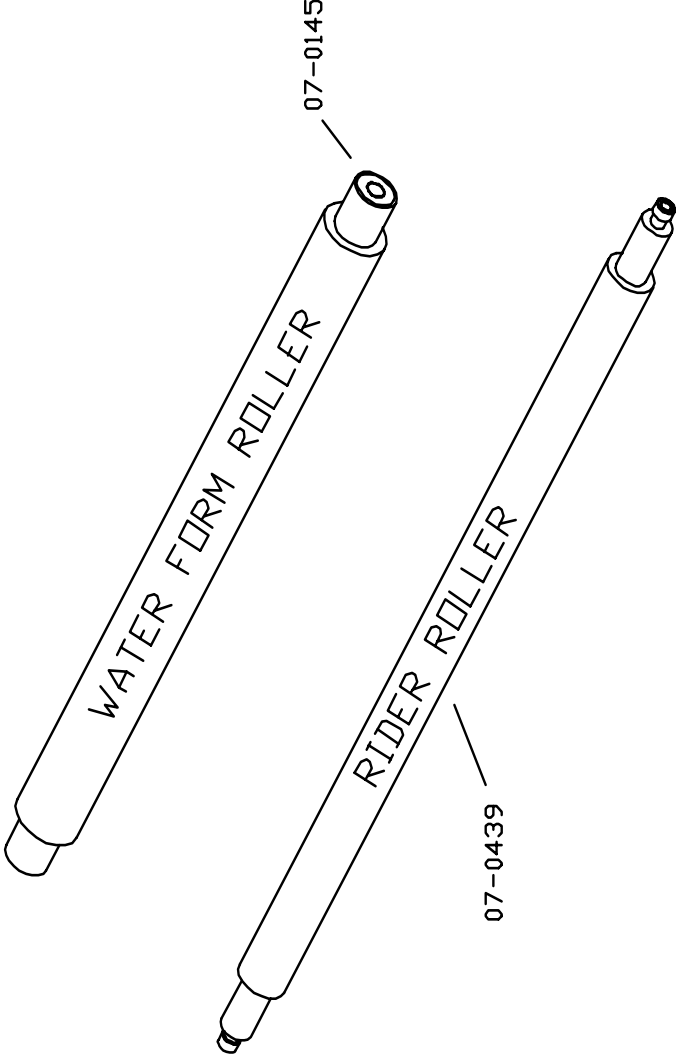

C248C12, 4-7-97

IMPRESSION CYLINDER OPERATION PANEL (OP-SIDE)

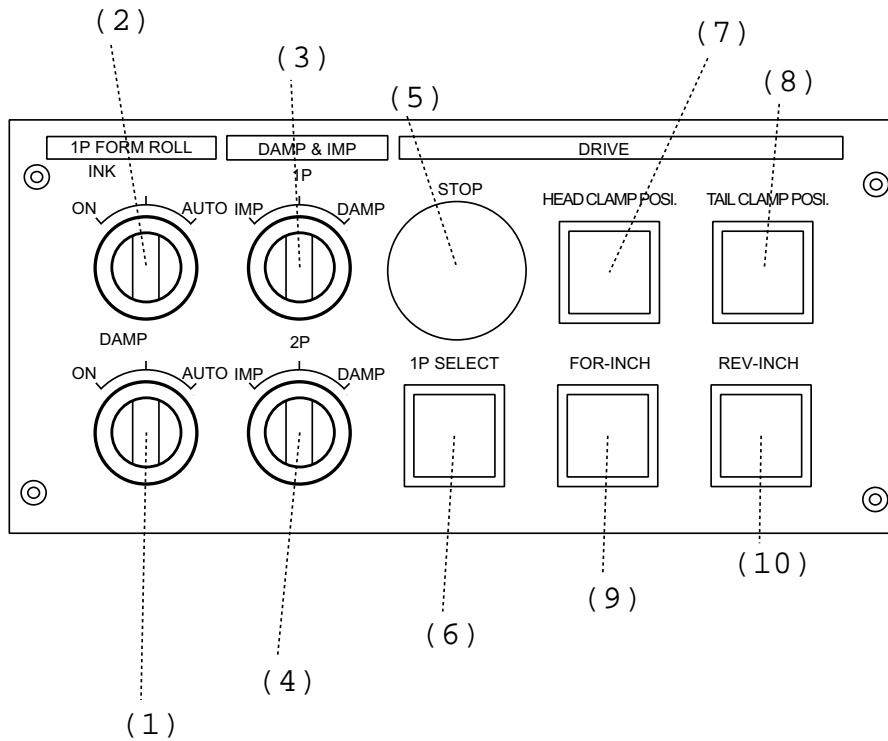

- (1) 1P dampening form roller selection switch
- (2) 1P inking form roller selection switch
- (3) 1P impression ON / dampening ON switch
- (4) 2P impression ON / dampening ON switch
- (5) Main drive stop switch
- (6) 1P selection switch

- (7) Plate cylinder head clamp positioning switch
- (8) Plate cylinder tail clamp positioning switch
- (9) Inching switch (Forward)
- (10) Inching switch (Reverse)

DELIVERY SECTION OPERATION PANEL (OP-SIDE)

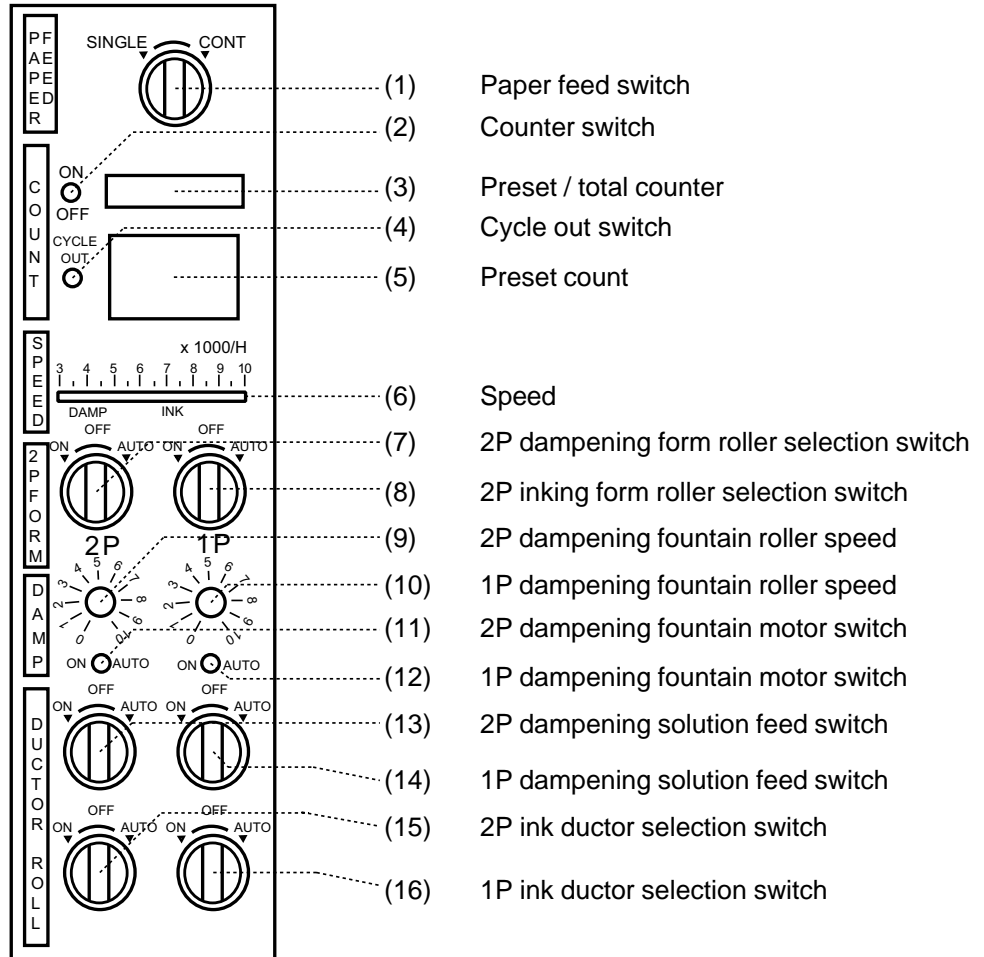



A Pamarco Technologies Inc. Company

11103 Indian Trail, Dallas, TX 75229 Phone 972-484-6808, Fax 800-365-6510
E-mail info@accel-us.com, Web Site www.accel-us.com