

# CROSS LAMINATED TIMBER

## Horizontal Diaphragm Design Example



*Our aim for this white paper is to provide a practical design method to determine the strength of a Cross Laminated Timber horizontal diaphragm and deflection due to lateral wind or seismic loads.*

### CLT HORIZONTAL DIAPHRAGM DESIGN

The design approach is based on compliance with engineered design of CLT in accordance with the 2015 International Building Code, reference standards, and other published information including manufacturer's literature.

#### Applicable Building Code, reference standards, and other information sources:

- *ICC, 2015 International Building Code*
- *ANSI/AWC NDS-2015 National Design Specification (NDS) for Wood Construction with Commentary*
- *AWC SDPWS-2015 Special Design Provisions for Wind and Seismic*
- *ANSI/APA PRG 320 – 2012 Standard for Performance-rated Cross-laminated Timber*
- *FP Innovations, US CLT (Cross-Laminated Timber) Handbook 2013*
- *ASCE 7-10 Minimum Design Loads for Buildings and Other Structures*
- *AISC 360-10 Specification for Structural Steel Buildings*
- *APA Product Report PR-L314 - CrossLam by Structurlam Products LP, February 20, 2014*
- *ICC-ES Evaluation Report ESR-3179 – ASSY Screws by MyTiCon Timber Connectors, October 2014*
- *Structurlam CrossLam Design Guide Imperial Version 11*
- *MyTiCon, CLT Connection Design Guide NDS*

#### PREPARED BY:

**Kris Spickler P.E.**  
Heavy Timber Group  
Structurlam Products LP  
Granite Bay, CA  
kspickler@structurlam.com  
www.structurlam.com



**Max Closen**  
Dipl.-Ing (FH), MaSc  
MyTiCon Timber  
Connectors Inc.  
Surrey, BC  
max@my-ti-con.com  
www.my-ti-con.com



**Philip Line, P.E.**  
American Wood Council  
Leesburg, VA  
pline@awc.org  
www.awc.org



**Martin Pohll P.E., S.E.**  
Martin Pohll Structural  
Engineering  
Rancho Murieta, CA  
mpohll@ranchomurieta.org

**Disclaimer** – *This white paper is intended for guidance only. The design professional of record should exercise good engineering judgement in the application of these guidance materials in a specific project.*

## EXAMPLE DESCRIPTION

This example presents the design of a CLT diaphragm in a manner that is analogous to common methods for design of wood structural panel diaphragms including limitations on diaphragm aspect ratio. Shear transfer between adjacent CLT panels is through attachment to plywood splines with screws or nails. Good detailing practice for design of such diaphragms is based on design recommendations of the US CLT Handbook 2013. These recommendations suggest seismic force-resisting connections, including panel to panel diaphragm connections, be sized to develop NDS yield limit equation Mode III or Mode IV yielding behavior and that chords be designed with adequate strength to develop the shear strength of the diaphragm connections.

For the purposes of this example, CLT panels are designed and detailed to function as a continuous diaphragm chord. Panels functioning as the continuous chord are tied together with metal ties at panel joints.

While test-based design values of fastener strength and stiffness are available in the product evaluation report or manufacturer's literature for the proprietary screws used in this example, strength and stiffness values are also determined in accordance with the NDS and NDS Commentary.

## DIAPHRAGM DESIGN TIPS

1. For this example the CLT panel joints are continuous in north-south and east-west directions (e.g. non-staggered panel layout). A staggered panel layout, common in plywood diaphragms, is also an acceptable option for CLT diaphragms.
2. For this example a diaphragm chord splice is located at mid-span and associated with maximum chord forces. Locating chord splices away from the location of maximum diaphragm moment will reduce the chord splice force.

## Diaphragm Design Flow Chart

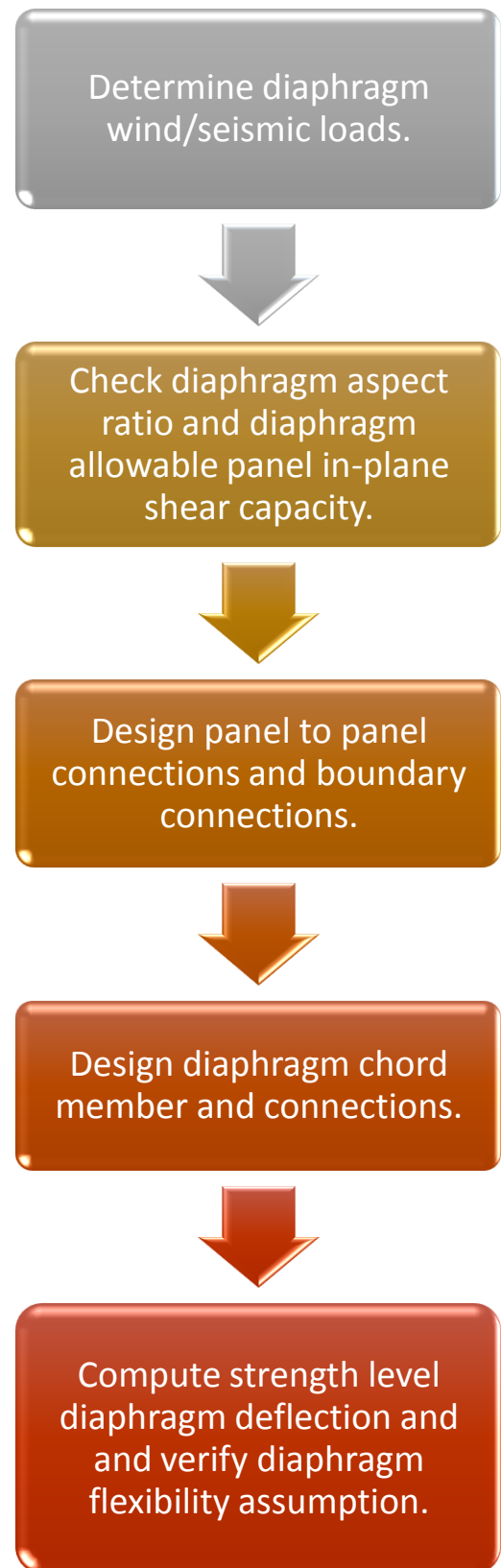

3. For this example, fastener slip is the biggest contributor to diaphragm deflection but this may not be the case for all CLT diaphragms.
4. The diaphragm in this example utilizes a plywood spline connection for shear transfer between adjacent CLT panels. Diaphragm capacity employing plywood splines should not exceed the permissible capacities associated with nailed wood structural panel diaphragms given in AWC SDPWS-2015, unless verified by testing.
5. The deflection calculation method described in this example can be used to assist in making a determination of diaphragm flexibility in accordance with ASCE 7-10 (see ASCE 7-10 Section 12.3.1). For diaphragms that are not idealized as flexible, requirements for torsion (Section 12.8.4.1), accidental torsion (Section 12.8.4.2) and amplification of accidental torsional moment (Section 12.8.4.3) are applicable as well as limitations associated with torsional irregularity, if present.
6. 2015 IBC Section 1604 allows idealization of a diaphragm as rigid as follows - a diaphragm is rigid for the purpose of distribution of story shear and torsional moment when the lateral deformation of the diaphragm is less than or equal to two times the average story drift. Where a diaphragm is idealized as rigid, additional provisions of ASCE 7-10 are applicable as noted above.
7. The simplified seismic criteria of ASCE 7-10 Section 12.14 includes special criteria to address torsional effects which must be met as part of the method. These special criteria enable use of the simplified criteria without required checking of seismic drift and are applicable for designs that utilize diaphragms that are idealized as either flexible or rigid.
8. Consult your local building official on application of building code provisions for design of the CLT diaphragm before performing a final design (for example, to address acceptable use of proprietary values of fastener resistance).

## CLT Horizontal Diaphragm Design Example

This design example is intended to evaluate a cross laminated timber diaphragm using Structurlam SLT3 Panels. The diaphragm strength and deflection is evaluated only in the north-south direction for seismic loads. The diaphragm is assumed to be flexible, but the assumption will be verified. Unless otherwise noted, the CLT diaphragm and connections are designed using allowable stress design loads while deflection due to seismic is based on strength design loads in accordance with ASCE 7. While not addressed in this example, special design force and detailing provisions for anchorage of concrete/masonry structural walls to diaphragms of ASCE 7 Section 12.11 are applicable for the design of CLT diaphragms. Additionally, the CLT splines should not be used to provide continuous cross ties required by Section 12.11.

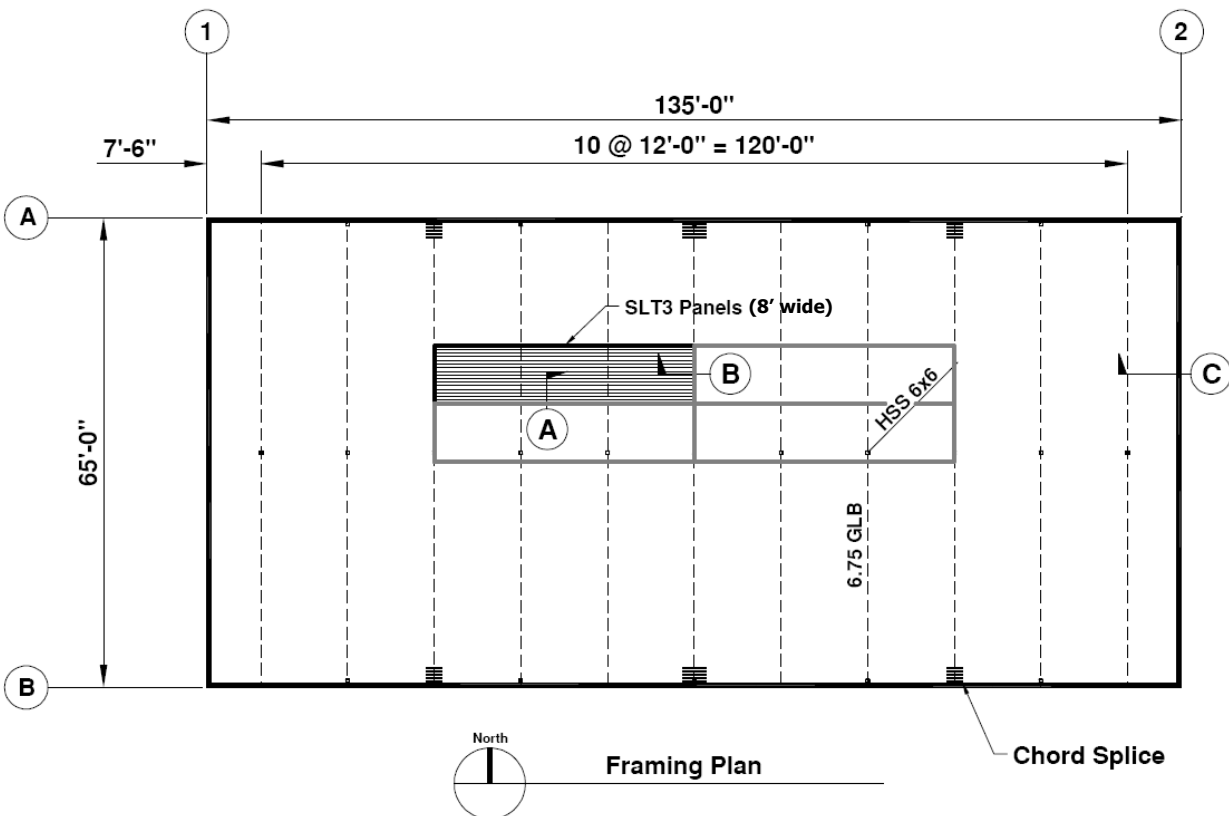

### Diaphragm Aspect Ratio

$$L/W = 135/65 = 2.07 < 4.0$$

### Seismic Loads

Strength Level Design Load

$$w_{EQ} = 1000 \text{ plf}$$

$$\text{Line 1 } V_{EQ} = (1000)(135/2) = 67,500 \text{ lbs}$$

$$v_{EQ} = 67,500/65 = 1038 \text{ plf}$$

ASD Level Design Load

$$v_{EQ} = (0.7)67,500/65 = 727 \text{ plf}$$

**NOTE:** Diaphragm aspect ratio limit of 4.0 for CLT with plywood spline joints is based on extension of SDPWS-2015 Table 4.2.4 aspect ratio limit for blocked wood structural panel diaphragms.

**NOTE:** Design load was derived elsewhere and governs over wind loads.

## Panel Allowable In-Plane Shear Capacity

$V_r = 2906 \text{ plf} > 727 \text{ plf}$

## Shear Wall and Diaphragm Applications

CrossLam® In-Plane Allowable Shear Capacity				
Panel d (in)	SLT3 3.90	SLT5 6.66	SLT7 9.42	SLT9 12.18
	<b>V<sub>r</sub> (lbs/ft)</b>			
	2906	5812	8718	11624

Reference: Structurlam CrossLam Design Guide Ver 12

## Panel to Panel Connection (Detail A with MyTiCon ASSY 3.0 Ecofast Screw)

**NOTE:** CLT panel in-plane shear capacity,  $V_r$ , is generally large compared to the panel to panel connection capacity.

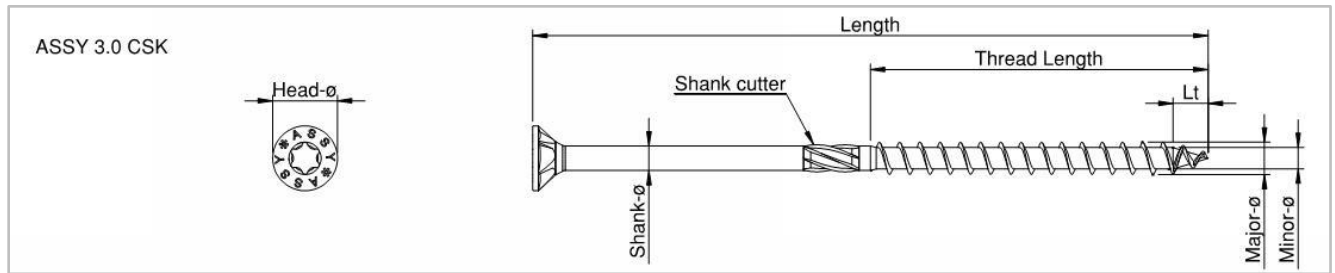

Reference: ICC-ES Evaluation Report ESR-3179 dated October 2014

## Detail A with MyTiCon ASSY 3.0 Ecofast Screw

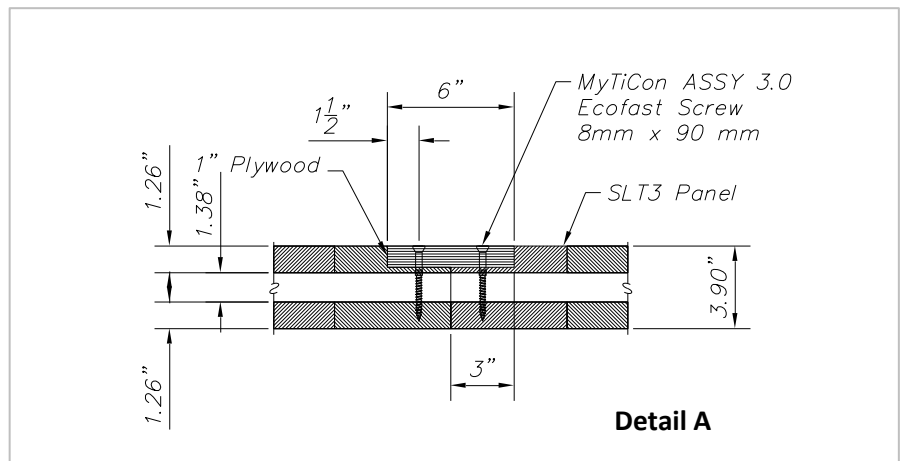

Screw Diameter,  $D = \text{Major Diameter} = 8.0 \text{ mm} (0.315 \text{ in.})$   
 Shank Diameter = 5.8 mm (0.228 in.)  
 Minor Diameter = 5.3 mm (0.209 in.)  
 Screw Length,  $L = 90 \text{ mm} (3.54 \text{ in.})$

$G = 0.42$  for Spruce-Pine-Fir STL3 Panel  
 $G = 0.42$  for plywood per NDS-2015 Table 12.3.3B

**NOTE:** Minimum end distances, edge distances and spacing of the screws must be sufficient to prevent splitting of the wood and must conform to the ICC evaluation report and/or the manufacturer's recommendations. See ICC ESR 3179 Table 5. Consult the screw manufacturer for Cyclic testing results.

Min Screw Spacing =  $5d = (5)(0.315) = 1.57 \text{ in.}$   
 Min Penetration =  $6d = (6)(0.315 \text{ in.}) = 1.89 \text{ in.}$   
 Actual Penetration =  $3.54 - 1.0 = 2.54 \text{ in.}$

ICC ESR 3179 Section 4.1.1

$D_r = 0.209$  in. (root diameter)

*ICC ESR 3179 Table 1*

$F_{vB} = 150,200$  psi

$l_m = (3.54$  in. screw length  $-1.0$  in. plywood thickness)  
 $= 2.54$  in.

$t_s = 1.00$  in.

$Z = 164$  lbs (Mode III<sub>s</sub>)

*NDS-2015 Section 12.3.1*

$C_D = 1.60$

*NDS-2015 Table 2.3.2*

$Z' = 164(1.60) = 262$  lbs

ASD Line 1 Shear = 727 plf

Required Spacing =  $(262)(12)/727 = 4.32$  in.

Use 4 in. spacing.

The shear capacity is governed by the bending yield strength of the screw in the side member (Mode III<sub>s</sub>). The capacity above uses the root diameter, but for cases where the screw shank diameter extends sufficiently beyond the shear plane, the shank diameter may be used in calculation of  $Z'$ . Using the shank diameter of 0.228 inch,  $Z = 178$  lbs (Mode III<sub>s</sub>) which provides a 9% increase in capacity. For short term wind or seismic loading,  $Z' = 178(1.60) = 285$  lb.

These same screws have been tested by MyTiCon with a SLT3 Panel and a 3/4" plywood spline. The allowable capacity based on dividing average test values by a factor of 5.0 (see ICC-ES AC233) results in  $Z = 242$  lbs per screw. For short term wind or seismic loading,  $Z' = (242)(1.60) = 388$  lbs. The NDS value of  $Z = 178$  lbs and  $Z' = 285$  lbs for wind or seismic loading are conservative relative to test-based value of  $Z$  and  $Z'$ .

The panel to panel connection is designed using the maximum diaphragm shear at Line 1. Panel to panel connections can be varied in zones along the diaphragm span to reflect the reduced shear forces toward the center of the diaphragm.

### **Panel Allowable Shear Capacity at Routed Section**

The rout for the plywood will reduce the shear capacity of the panel. The remaining capacity is based upon center lamination only.

$V = (1.38$  thick) $(12.0$  width) $(135$  psi  $F_v$  for SPF) $(1.60 C_D)/1.5 = 2385$  lbs/ft  $> 727$  lbs/ft.

### **Panel to Panel Connection (Detail A with Nails)**

Use 1.0 in. plywood spline with 16d Common Nails (0.162" diameter x 3-1/2" long x 0.344" head diameter)

$Z = 109$  lb/nail

*NDS-2015 Table 11R*

$C_D = 1.60$

*NDS-2015 Table 2.3.2*

$C_{di} = 1.10$

*NDS-2015 Section 12.5.3*

$Z' = 109(1.60)(1.10) = 192$  lbs

*NDS-2015 Section 12.3.1*

Required Spacing =  $(192)(12)/727 = 3.16$  in.

Use 3 in. spacing.

Minimum Nail Spacing =  $15d = (15)(0.162) = 2.43$  in.

*NDS-2015 Table C12.1.6.6*

Side Member Thickness in. $t_s$	Nail Diameter in. $D$	Common Wire Nail		G=0.67 Red Oak	G=0.55 Mixed Maple Southern Pine	G=0.5 Douglas Fir-Larch	G=0.49 Douglas Fir-Larch (N)	G=0.46 Douglas Fir(S) Hem-Fir(N)	G=0.43 Hem-Fir	G=0.42 Spruce-Pine-Fir	G=0.37 Redwood (open grain)	G=0.36 Eastern Softwoods Spruce-Pine-Fir(S) Western Cedars Western Woods	G=0.35 Northern Species	
		Box Nail	Sinker Nail											Pennyweight
1	0.099 <sup>s</sup>	8d	7d	56	53	51	50	49	48	47	44	44	43	
	0.113 <sup>s</sup>	6d <sup>4</sup>	8d	73	68	66	66	64	62	61	58	57	56	
	0.120 <sup>s</sup>		10d	82	77	75	74	72	70	69	65	64	63	
	0.128		10d	91	87	85	84	82	80	79	74	73	72	
	0.131		8d	93	89	87	87	85	83	82	77	77	75	
	0.135		16d	12d	97	93	91	90	89	87	86	82	81	80
	0.148		10d	20d	16d	109	104	101	101	99	97	91	91	90
	0.162		16d	40d	124	118	115	115	113	110	109	104	103	102
	0.177			20d	137	131	128	127	125	122	121	115	114	112
	0.192		20d	30d	141	135	131	131	128	125	124	118	117	116

Reference: NDS Table 11R

### Detail A with Nails

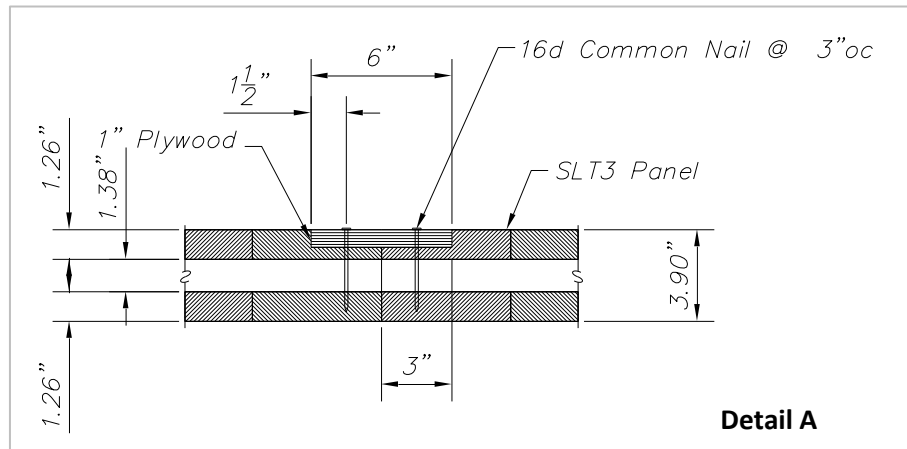

### Panel Splice over Glulam Beam (GLB) (Detail B)

Z = 194 lbs for 5/16" x 7 1/8" (min) screw  
 G = 0.42 for SLT3 Panel  
 Side member thickness = 4.0 in.  
 Side member loaded perpendicular to grain and main member loaded parallel to grain.

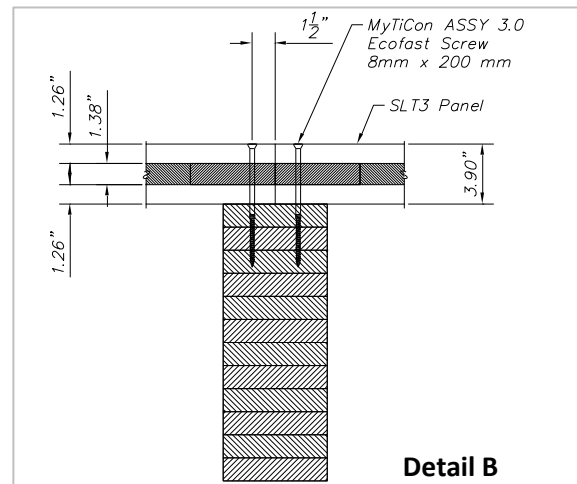

$C_D = 1.60$   
 $Z' = (1.6)(194) = 310$  lbs

Required Spacing =  $(310)(12)/727 = 5.12$  in.  
 Use 5 in. spacing

NDS-2015 Table 2.3.2

**NOTE:** Spacing based on 727 plf although a reduced shear force at the first interior GLB could be used.

TABLE 2—REFERENCE LATERAL DESIGN VALUES (Z)<sup>1,2,3,4,5</sup>

FASTENER DESIGNATION <sup>1</sup>	SIDE MEMBER THICKNESS (inches)	FASTENER PENETRATION INTO MAIN MEMBER (inches)	REFERENCE LATERAL DESIGN VALUE, Z (lbf) FOR SPECIFIC GRAVITIES OF											
			0.33			0.42			0.49			0.55		
			Z <sub>1</sub>	Z <sub>1/3</sub>	Z <sub>1</sub>	Z <sub>1</sub>	Z <sub>1/3</sub>	Z <sub>1</sub>	Z <sub>1</sub>	Z <sub>1/3</sub>	Z <sub>1</sub>	Z <sub>1</sub>	Z <sub>1/3</sub>	Z <sub>1</sub>
1/4" x 4"	2	1 3/4	131	131	131	185	185	185	213	213	213	237	237	237
1/4" x 4 3/4"	2	2 1/2	142	142	142	185	185	185	213	213	213	237	237	237
1/4" x 5 1/2"	2 3/4	2 1/2	148	148	148	185	185	185	213	213	213	237	237	237
1/4" x 6 1/4"	3 1/2	2 1/2	148	148	148	185	185	185	213	213	213	237	237	237
1/4" x 7 1/8"	4	2 1/8	148	148	148	185	185	185	213	213	213	237	237	237
1/4" x 7 1/2"	5 1/2	2 1/8	148	148	148	185	185	185	213	213	213	237	237	237
1/4" x 8 3/8"	6	2 3/8	148	148	148	185	185	185	213	213	213	237	237	237
1/4" x 9 1/2"	7	2 1/4	148	148	148	185	185	185	213	213	213	237	237	237
1/4" x 11 1/4"	7 1/2	4	148	148	148	185	185	185	213	213	213	237	237	237
1/4" x 11 3/4"	8	3 1/2	148	148	148	185	185	185	213	213	213	237	237	237
1/4" x 11 3/4"	9	2 1/2	148	148	148	185	185	185	213	213	213	237	237	237
5/16" x 4 3/4"	2	2 7/16	184	131	131	234	187	187	280	224	224	311	249	249
5/16" x 5 1/2"	2 3/4	2 7/16	185	148	148	243	194	194	280	224	224	311	249	249
5/16" x 6 1/4"	2 3/4	3 3/16	194	156	156	243	194	194	280	224	224	311	249	249
5/16" x 7 1/8"	3 1/2	3 7/16	194	156	156	243	194	194	280	224	224	311	249	249
5/16" x 7 1/8"	4	2 13/16	194	156	156	243	194	194	280	224	224	311	249	249
5/16" x 8 3/8"	5 1/2	2 13/16	194	156	156	243	194	194	280	224	224	311	249	249
5/16" x 9 1/4"	6	2 3/4	194	156	156	243	194	194	280	224	224	311	249	249

Reference: ICC-ES Evaluation Report ESR-3179 dated October 2014

### Panel Connection at Diaphragm Boundary (Detail C)

Use 5 inch spacing. Loads and screws are the same as used for the design of the panel connection over interior GLB.

### Diaphragm Chords

Use top and bottom laminations of SLT3 panel at diaphragm edges to function as the diaphragm chord.

Use Chord Width = 27.5 in.

$$\text{Diaphragm Moment at } X = 67.5 \text{ ft from Line 1} = 1000(135)^2/8 = 2,278,125 \text{ ft-lb}$$

$$\text{Diaphragm Moment at } X = 31.5 \text{ ft from Line 1} = (1000)(31.5)(135.0 - 31.5)/2 = 1,630,125 \text{ ft-lbs}$$

$$\text{Chord Force} = M/d$$

$$\text{Assume } d = [(65.0)(12) - (2)(7.625 \text{ wall}) - (2)(13.75 \text{ wall to center chord})]/12 = 61.44 \text{ feet}$$

### Strength Level Chord Forces

$$\text{Chord Force at } X = 67.5 \text{ ft from end} = (2,278,125)/61.44 = 37,079 \text{ lbs}$$

$$\text{Chord Force at } X = 31.5 \text{ ft from end} = (1,630,125)/61.44 = 26,531 \text{ lbs}$$

### ASD Chord Forces

$$\text{Chord Force at } X = 67.5 \text{ ft from end} = (0.7)(2,278,125)/61.44 = 25,956 \text{ lbs}$$

$$\text{Chord Force at } X = 31.5 \text{ ft from end} = (0.7)(1,630,125)/61.44 = 18,572 \text{ lbs}$$

It is recommended that the chords be designed to be stronger than the shear strength of the diaphragm shear connections. The capacity of the diaphragm is limited by the panel to panel fasteners. Fasteners were required at 4.32 in. spacing but 4.0 in. spacing was provided. Therefore, increase chord forces by (4.32/4.00) = 1.08 when checking chord strength.

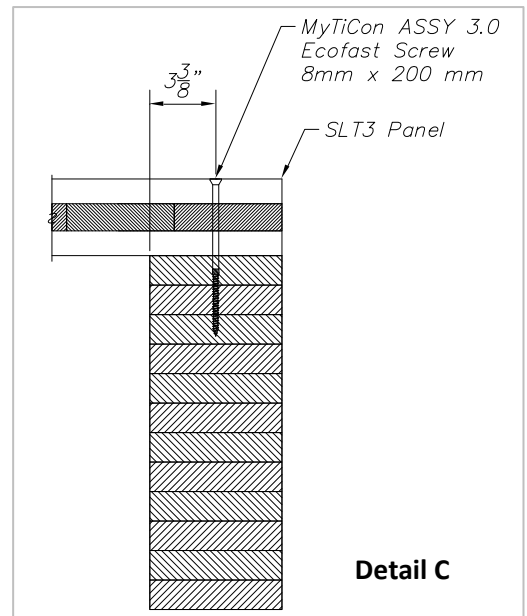



TABLE A1.  
ALLOWABLE DESIGN PROPERTIES<sup>(a,b,c)</sup> FOR PRG 320 CLT (for use in the U.S.)

CLT Grades	Major Strength Direction						Minor Strength Direction					
	F <sub>b,0</sub> (psi)	E <sub>0</sub> (10 <sup>6</sup> psi)	F <sub>1,0</sub> (psi)	F <sub>c,0</sub> (psi)	F <sub>v,0</sub> (psi)	F <sub>t,0</sub> (psi)	F <sub>b,90</sub> (psi)	E <sub>90</sub> (10 <sup>6</sup> psi)	F <sub>1,90</sub> (psi)	F <sub>c,90</sub> (psi)	F <sub>v,90</sub> (psi)	F <sub>t,90</sub> (psi)
E1	1,950	1.7	1,375	1,800	135	45	500	1.2	250	650	135	45
E2	1,650	1.5	1,020	1,700	180	60	525	1.4	325	775	180	60
E3	1,200	1.2	600	1,400	110	35	350	0.9	150	475	110	35
E4	1,950	1.7	1,375	1,800	175	55	575	1.4	325	825	175	55
V1	900	1.6	575	1,350	180	60	525	1.4	325	775	180	60
V2	875	1.4	450	1,150	135	45	500	1.2	250	650	135	45
V3	975	1.6	550	1,450	175	55	575	1.4	325	825	175	55

For SI: 1 psi = 0.006895 MPa

(a) See Section 4 for symbols.

(b) Tabulated values are allowable design values and not permitted to be increased for the lumber size adjustment factor in accordance with the NDS. The design values shall be used in conjunction with the section properties provided by the CLT manufacturer based on the actual layout used in manufacturing the CLT panel (see Table A2).

(c) Custom CLT grades that are not listed in this table shall be permitted in accordance with Section 7.2.1

Reference: APA PRG320 Table A1

### Tension Capacity

$$F_{T0} = 450 \text{ psi}$$

$$C_D = 1.60$$

$$F'_{T0} = (450 \text{ psi})(1.6) = 720 \text{ psi}$$

$$T_{\text{PARALLEL}} = F'_{T0} A_{\text{PARALLEL}}$$

$$A_{\text{PARALLEL}} = (2)(1.26)(27.5) = 69.30 \text{ in}^2$$

$$A_{\text{net}} = 69.30 - (5 \text{ screws})(0.228 \text{ shank diameter}) \\ \times (3.54 \text{ length} - 0.25 \text{ tip}) = 65.55 \text{ in}^2$$

$$T_{\text{PARALLEL}} = (720)(65.55) = 47,196 \text{ lbs} > 25,956(1.08) \\ = 28,032 \text{ lbs}$$

APA PRG 320 Table A1 for Grade V2  
NDS-2015 Table 2.3.2

CLT Handbook, 2013, Chapter 3  
Section 2.3 Eqn 9

Area of layers with fibers running  
parallel to the direction of the load

NDS-2015 Section 3.8

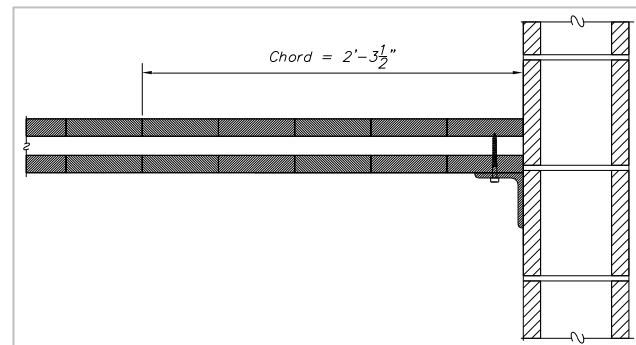

### Bending

$$w_{DL} = 10.5 \text{ psf self weight} + 20 \text{ psf DL} = 30.5 \text{ psf}$$

$$M_{DL} = -439 \text{ ft-lb/ft maximum for 3 - 12' continuous spans}$$

$$M_{\text{ALLOW}} = 1800 \text{ ft-lb/ft}$$

APA PR-L314 Feb 20, 2014

### Bending and Axial Tension

$$= (1.08)(25,956)/47,421 + 439/(1.6)1800$$

$$= 0.591 + 0.152 = 0.743 < 1.0$$

NDS-2015 Eqn 3.9-1 and Section 3.9  
Commentary

## Compression

Unbraced length = 144 inch

$EI_{eff0} = 79,000,000 \text{ lb-in}^2/\text{ft}$

$GA_{eff0} = 490,000 \text{ lb/ft}$

$F_{c0} = 1150 \text{ psi}$

$K_S = 11.5$

$$EI_{app} = \frac{EI_{eff}}{1 + \frac{K_S EI_{eff}}{GA_{eff} L^2}} = \frac{79,000,000}{1 + \frac{(11.5)(79,000,000)}{490,000(144)^2}}$$
$$= 72,516,073 \text{ lb-in}^2/\text{ft}$$

$$EI_{app-min} = 0.5184 EI_{app}$$
$$= (0.5184)(72,516,073) = 37,592,332 \text{ lb-in}^2/\text{ft}$$

$$P_{cE} = \frac{\pi^2 EI_{app-min}}{l_e^2} = \frac{\pi^2 (37,592,332)}{(144)^2}$$
$$= 17,893 \text{ lbs/ft}$$

$$P_c^* = F_{c0} C_D A = (1150)(1.60)(1.26)(2)(12 \text{ inch width})$$
$$= 55,642 \text{ lb/ft}$$

$$C_p = \frac{1 + \left(\frac{P_{cE}}{P_c^*}\right)}{2c} - \sqrt{\left[\frac{1 + \left(\frac{P_{cE}}{P_c^*}\right)}{2c}\right]^2 - \frac{P_{cE}}{P_c^*}}$$
$$= \frac{1 + \left(\frac{17,893}{55,642}\right)}{2(0.90)} - \sqrt{\left[\frac{1 + \left(\frac{17,893}{55,642}\right)}{2(0.90)}\right]^2 - \frac{17,893}{55,642}}$$
$$= 0.3079$$

$$P_{ALLOW} = C_p F_{c0} C_D A$$
$$= (0.3079)(1150)(1.60)(1.26)(2)(12 \text{ inch width})$$
$$= 17,131 \text{ lb/ft}$$

$$P_{ALLOW \text{ Total}} = (17,131)(27.5/12) = 39,258 \text{ lb}$$

$$P_{cE} = (17,893)(27.5/12) = 41,004 \text{ lb}$$

APA PR-L314 Feb 20, 2014

CLT Handbook, 2013, Chapter 3 Table 2  
distributed load pinned ends and NDS-2015  
Table 10.4.1.1

CLT Handbook, 2013, Chapter 3 Eqn 5 and  
NDS-2015 Section 10.4 and Commentary

CLT Handbook, 2013, Chapter 3 Eqn 8 and NDS  
2015 Section 10.4 Commentary

CLT Handbook, 2013, Chapter 3 Section 2.2.2  
and NDS-2015 Section 3.7 Commentary

## Combined Bending and Compression

$$\left[ \frac{P}{P_{allow}} \right]^2 + \frac{M}{M_{allow} \left( 1 - \frac{P}{P_{cE}} \right)}$$

$$= \left[ \frac{(25,956)(1.08)}{39,258} \right]^2 + \frac{439}{(1800)(1.6) \left( 1 - \frac{(25,956)(1.08)}{(41,004)} \right)}$$

$$= 0.509 + 0.481 = 0.992$$

CLT Handbook, 2013, Chapter 3 Section 2.4  
Eqn 10 and NDS-2015 Section 3.9 Commentary

## Chord Splice at Midspan

Use 5 - PL 1/4x2 ASTM A36 Steel Plates with 12 – 0.315 in. x 3.54 in. long (i.e. 8mm dia x 90 mm long) MiTiCon ASSY 3.0 screws each end spaced at 3.00 in. on center; 0.750 in. steel end distance; 3.50 in. wood end distance; 3/8 in. diameter holes in plate; space plates at 5.50 in.

$$\phi P_N = (5 \text{ each})(0.90)(0.25)(2.0)(36)$$

$$= 81.0 \text{ kips} > (37.079)(1.08)$$

$$= 40.05 \text{ kips}$$

*AISC 360-10 Eqn D2-1*

$$\phi P_N = (5 \text{ each})(0.75)(0.25)(2.0 - 0.375)(58)$$

$$= 88.36 \text{ kips} > 40.05 \text{ kips}$$

*AISC 360-10 Eqn D2-2*

$$D_r = 0.209 \text{ in. (root diameter)}$$

$$F_{yb} = 150,200 \text{ psi}$$

*ICC ESR 3179 Table 1*

$$l_m = (3.54 \text{ in. screw length} - 0.25 \text{ in. plate thickness})$$

$$= 3.29 \text{ in.}$$

$$t_s = 0.25 \text{ in.}$$

$$Z = 293 \text{ (Mode IIIs)}$$

*NDS-2015 Section 12.3.1*

$$C_D = 1.60$$

*NDS-2015 Table 2.3.2*

$$Z' = 293(1.60) = 469 \text{ lbs}$$

*NDS-2015 Section 12.3.1*

$$\text{Allowable Screw Shear} = 1320 \text{ lbs} > 293 \text{ lbs}$$

*ICC ESR 3179 Table 1 Steel Shear*

$$\text{Minimum Spacing} = 5d = (5)(8 \text{ mm})/25.4$$

$$= 1.57 \text{ inch} < 3.0 \text{ inch}$$

*ICC ESR 3179 Table 5*

$$\text{Minimum End Distance in Wood} = 10d$$

$$= (10)(8 \text{ mm})/25.4 = 3.15 \text{ in.} < 3.50 \text{ in.}$$

*ICC ESR 3179 Table 5*

$$L_C = (3.0 - 0.4375) = 2.5625 \text{ in. between screws}$$

$$L_C = (0.75 - 0.4375/2) = 0.531 \text{ in. at ends}$$

**NOTE:** Check steel bearing at bolt holes. Use diameter 1/16" larger than hole diameter (*AISC 360-10 Section B4.3.b*)

$$\text{Bearing } \phi R_N = (0.75)(1.2)(0.531)(0.25)(58) = 6.93 \text{ kip}$$

*AISC 360-10 Eqn J3-6a*

$$\text{Bearing } \phi R_N = (0.75)(2.4)(0.228 \text{ shank})(0.25)(58) = 5.95 \text{ kip}$$

$$\text{Allowable Force} = (5 \text{ each})(12 \text{ screws})(469 \text{ lb/screw})$$

$$= 28,140 \text{ lbs} > (25,956)(1.08) = 28,032 \text{ lbs}$$

**NOTE:** Z' value from *NDS-2015 Section 12.3-1 controls*

Assume screws transfer load from steel plate to upper lamination only and load is transferred from upper lamination to lower lamination. The allowable load transfer between the upper and lower lamination is conservatively limited by the allowable radial tension stress.

$F_{vx} = 135 \text{ psi}$   
 $C_{vr} = 0.72$   
 $F_{rt} = (1/3)F_{vx}C_{vr} = (1/3)(135)(0.72) = 32.4 \text{ psi}$   
 $F'_{rt} = C_D F_{rt} = (1.6)(32.4) = 51.8 \text{ psi}$   
 Chord Force =  $(25,596)(1.08) = 28,032 \text{ lbs}$   
 Length from end of panel to last screw = 36.5 inch  
 Allowable load transfer from upper lamination to lower lamination =  $(51.8 \text{ psi})(36.5 \text{ length})(27.5 \text{ width})$   
 $= 51,994 \text{ lbs} > (0.5)(\text{Chord Force})$   
 Use tension capacity based upon both laminations parallel to load.

APA PRG 320 Table A1 for Grade V2  
 NDS-2015 Section 5.3.10  
 NDS-2015 Section 5.3.10

**NOTE:** For this example, the use of radial tension was judged to be a conservative approach relative to specific values of rolling shear. The force transfer between laminations is shown to be adequate to develop the chord force in the parallel lamination on the bottom of the CLT panel. A similar approach can be taken for panels with a greater number of plies (e.g. 5 or 7 ply panel) or can be accommodated by alternate detailing such as use of greater width of the directly connected layer or use of connections on both top and bottom faces of the CLT panel. Alternately, the CMU wall with reinforcing steel or perimeter support beam can be designed for use as the diaphragm chord.

### Row Tear-Out Capacity

$F_{v0} = 135 \text{ psi}$   
 $F'_{v0} = (135 \text{ psi})(1.6) = 216 \text{ psi}$   
 $Z'_{RT} = \sum_{i=1}^{n_{row}} n_i F'_V t S_{critical}$

APA PRG 320 Table A1 for Grade V2  
 NDS-2015 Section Appendix E.3

Assume tear-out occurs in upper lamination only  
 Tear-out Depth in Upper Lam = 1.26 in.  
 $Z_{RT}' = (5 \text{ rows})(12 \text{ screws})(216 \text{ psi})(1.26)(3.00 \text{ spacing})$   
 $= 48,989 \text{ lbs} > 28,032 \text{ lbs}$

### Group Tear-Out Capacity

Assume only upper lamination is effective  
 $Z_{GT}' = Z_{RT-1}'/2 + Z_{RT-n}'/2 + F'_T A_{group-net}$   
 $Z_{RT-1}' = Z_{RT-n}' = (12 \text{ screws})(216 \text{ psi})(1.26 \text{ thick})(3.00 \text{ spacing})$   
 $= 9,798 \text{ lbs}$   
 $F'_T A_{group-net} = (720 \text{ psi})(1 \text{ lam})(1.26 \text{ thick})(5 \text{ rows} - 1)$   
 $(5.50 \text{ row space} - 0.228 \text{ diameter}) = 19,131 \text{ lbs}$   
 $Z_{GT}' = (9,798/2) + (9,798/2) + 19,131 = 28,929 \text{ lbs} > 28,032 \text{ lbs}$

NDS-2015 Section Appendix E.4

## Chord Splice at Midspan (Detail D)

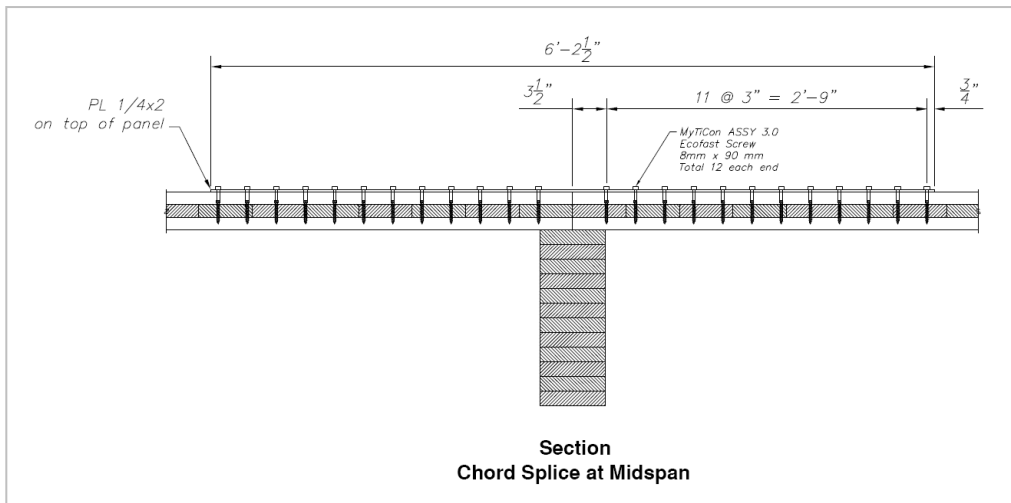
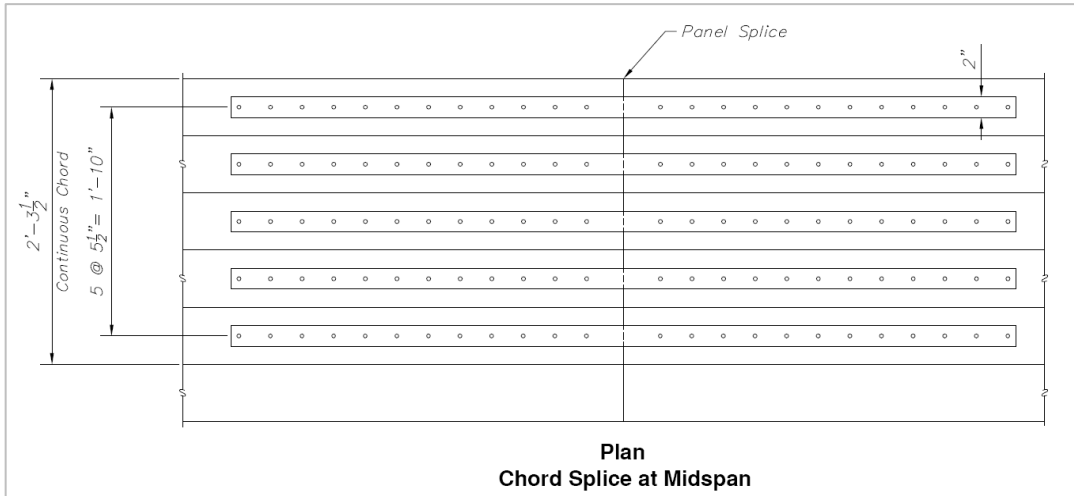

### Chord Splice at X = 31.5 ft from ends

Use 5 - PL 1/4x2 ASTM A36 Steel Plates with 9 - 0.315 in. x 3.54 in. long (i.e. 8mm dia x 90 mm long) MyTiCon ASSY 3.0 screws each end spaced at 3.00 in. on center; 0.750 in. steel end distance; 3.50 in. wood end distance; 3/8 in. diameter holes in plate.

Allowable Force = (5 each)(9 screws)(469 lb/screw) = 21,105 lbs > 18,572(1.08) = 20,058 lbs

### Strength Level Diaphragm Seismic Deflection

$$\delta_{dia} = \frac{5vL^3}{8EAW} + \frac{vL}{4G_v t_v} + CLe_n + \frac{\Sigma(x\Delta_c)}{2W}$$

$$w_{EQ} = 1000 \text{ plf}$$

$$v_{EQ} = 67,500/61.44 = 1099 \text{ plf}$$

**NOTE:** Deflection equation per ANSI/AWC SDPWS-2015 Eqn C4.2.2-1 adapted to account for CLT Panel Size.

## Deflection Due to Bending

$$\delta = 5vL^3/8EAW$$

$$A = (2 \text{ laminations})(1.26)(27.5) = 69.30 \text{ in}^2$$

$$E = 1,400,000 \text{ psi}$$

$$\delta = (5)(1099)(135)^3/(8)(1,400,000)(69.30)(61.44) = 0.284 \text{ in.}$$

## Deflection Due to Shear

$$\delta = vL/4G_v t_v$$

$$v = wL/2B$$

$$t_v = A/B$$

$$\delta = wL^2/8AG$$

where B = diaphragm width

where A = area of diaphragm

by substitution, deflection due to shear can be expressed in terms of apparent shear stiffness GA.

**NOTE:** The in-plane shear stiffness of the CLT panels has not yet been tested by Structurlam, but tests on other CLT panels have resulted in proposed equations to estimate the stiffness.

$$G_{eff,CA} = \frac{Kb^2 n_{CA} m^2}{5t_{gross}(m^2 + 1)}$$

$$G_{eff,CLT} = \left( \frac{1}{G_{lam}} + \frac{1}{G_{eff,CA}} \right)^{-1}$$

**NOTE:** Equations for shear stiffness  $G_{eff}$  are in accordance with Flaig M., Blaß H. J.: Shear strength and shear stiffness of CLT-beams loaded in plane. In: Proceedings. CIB-W18 Meeting 46, Vancouver, Canada, 2013, Paper 46-12-3.

K = slip modulus of crossing areas

b = width of lamelle

m = number of longitudinal lamellae

$n_{CA}$  = number of glue lines within element thickness

$t_{gross}$  = 3.90 inch for SLT3

$G_{lam} = E_0/16 = 1,400,000/16 = 87,500 \text{ psi}$

Use  $K = 4.0 \text{ N/mm}^3 = 14735 \text{ lb/in}^3$

Use  $b = 5.50 \text{ in.}$

Use  $m = 17$  for 96 in. panel width

Use  $n_{CA} = 2$  for SLT3

APA PRG 320-2012 for Grade V2

$$G_{eff,CA} = \frac{(14735)(5.50)^2(2)(17)^2}{5(3.90)(17^2 + 1)} = 45,559 \text{ psi}$$

$$G_{eff,CLT} = \left( \frac{1}{87,500} + \frac{1}{45,559} \right)^{-1} = 29,960 \text{ psi}$$

Recommended  $G_{eff}$

Panel	STL3	SLT5	SLT7	SLT9
$G_{eff}$	30,000 psi	33,000 psi	34,000 psi	35,000 psi

$$GA = (30,000)(3.90)(12) = 1,404,000 \text{ lbs/ft}$$

$$\delta = (1000 \text{ lb/ft})(135 \text{ ft})^2(12 \text{ in/ft})/(8)(1,404,000 \text{ lb/ft})(65 \text{ ft}) = 0.300 \text{ inch}$$

## Deflection Due to Fastener Slip at Panel to Panel Joints

$$\delta = CLe_n$$

The C term for deflection due to fastener slip in a CLT diaphragm is based on the derivation approach given in Appendix Section A4.1.4 of *Applied Technology Council, Guidelines for the Design of Horizontal Wood Diaphragms, September 1981*. For the case of uniformly loaded CLT diaphragm, the contribution of fastener slip to diaphragm deflection varies by Panel Length,  $P_L$  and Panel Width,  $P_W$ , as follows:

$$C = \frac{\frac{1}{P_L} + \frac{1}{P_W}}{2} = \frac{\frac{1}{36} + \frac{1}{8}}{2} = 0.076$$

#### Recommended C term

Panel Size WxL	8'x12'	8'x16'	8'x24'	8'x32'	8'x36'	8'x40'
C	0.104	0.094	0.083	0.078	0.076	0.075

$$\text{Load Slip Modulus} = \gamma = (180,000/2) D^{1.5}$$

$$\gamma = 90,000 (0.209)^{1.5} = 8,600 \text{ lb/in.}$$

$$\text{Fastener Force} = (1038 \text{ lb/ft}) / (3 \text{ screws/ft}) = 346 \text{ lb/screw}$$

$$e = 346 / 8,600 = 0.040 \text{ in.}$$

$$\delta = (0.076)(135)(0.040) = 0.410 \text{ in.}$$

#### Deflection Due to Chord Splice Slip

$$\text{Load Slip Modulus} = \gamma = (270,000/2) D^{1.5}$$

$$\gamma = 135,000 (0.209)^{1.5} = 12,899 \text{ lb/in.}$$

$$\Delta_c = 2(T \text{ or } C) / \gamma n = (2)(37,079) / (12,899)(60) = 0.096 \text{ in.}$$

at midspan

$$\Delta_c = 2(T \text{ or } C) / \gamma n = (2)(26,531) / (12,899)(45) = 0.091 \text{ in.}$$

at x = 31.5 ft

$$\Sigma(x\Delta_c) / 2W = [(31.5)(0.091) + 67.5(0.096) + (31.5)(0.091)] / 2(61.44) = 0.099 \text{ in.}$$

Assume slip on compression chord = slip on tension chord

$$\delta = (0.099)(2) = 0.198 \text{ in.}$$

#### Total Diaphragm Deflection

$$\text{Total Deflection} = 0.284 + 0.300 + 0.410 + 0.198$$

$$= 1.192 \text{ in. using NDS estimate of fastener slip.}$$

#### MyTiCon Test Results

For screws spaced 4" oc

$$\text{Strength Level Force} = (1038)(4) / 12 = 346 \text{ lbs/screw}$$

$$\text{Force} = (346 \text{ lb}) (0.004448 \text{ kN/lb}) = 1.54 \text{ kN/screw}$$

The MyTiCon average test results shown below indicate a wood displacement = 1.4 mm (0.055 in.) corresponding to 1.5 kN force per screw.

$$e_n = 0.055 \text{ in.}$$

$$\delta = (0.076)(135)(0.055) = 0.566 \text{ in.}$$

$$\text{Total Displacement} = 0.284 + 0.300 + 0.566 + 0.198$$

$$= 1.348 \text{ in. using test values for fastener slip.}$$

**NOTE:** Fastener slip contribution is based on the primary panel size used to compose the overall diaphragm dimensions. Based on inspection of the C term, the effect of the smaller length panels (i.e. 31.5') on nail slip contribution to deflection for this example is less than 5%.

#### NDS-2015 Section 10.3.6

**NOTE:** Reference #188 in NDS C11.3.6 (Zahn, J. J., Design Equation for Multiple-Fastener Wood Connections, Madison, WI, U.S. Department of Agriculture, Forest Service, Forest Products Laboratory, 1991) indicates that half of the NDS slip modulus is an appropriate value for bearing perpendicular to the grain. For this example, half the load slip modulus is used to account for possible influence of perpendicular crossing layers.

#### NDS-2015 Section 10.3.6

**NOTE:** For this example, half of the load slip modulus is used to account for possible influence of perpendicular crossing layers.

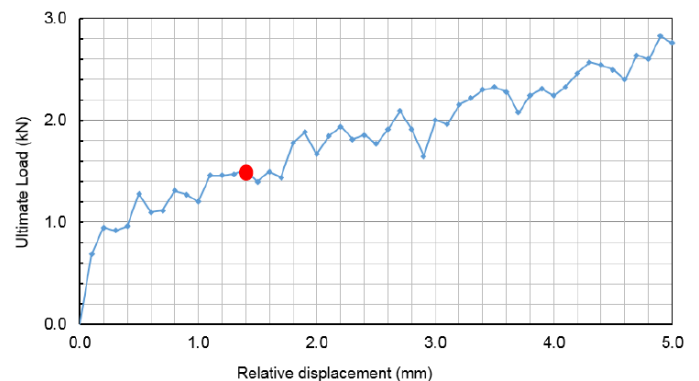

## Verify Flexible Diaphragm Assumption

ASCE 7-10 Section 12.3.1.3 permits diaphragms to be idealized as flexible where the computed maximum in-plane deflection of the diaphragm under lateral load is more than two times the average story drift of adjoining vertical elements of the seismic force-resisting system of the associated story under equivalent tributary lateral load.

The average story drift in the north-south direction for the CMU walls was computed in accordance with ASCE 7-10 Section 12.8.6 as  $\Delta = \delta_x = 0.10$  in.

Diaphragm Deflection = 1.192 >  $2\Delta = (2)(0.10) = 0.20$

The diaphragm can be assumed to be flexible.

**NOTE:** For this example, diaphragm deflection is compared to the average story drift of adjoining shear walls and the original assumption of flexible is verified. While distribution of forces to vertical elements based on semi-rigid diaphragm analysis is not undertaken in this example, the method of calculation of the diaphragm deflection can be used to establish diaphragm stiffness for semi-rigid diaphragm analysis. A generally acceptable alternative to semi-rigid diaphragm analysis is the envelope analysis where distribution of horizontal diaphragm shear to each vertical resisting element is the larger of the shear forces resulting from analyses where the diaphragm is idealized as flexible and the diaphragm is idealized as rigid.

## Alternative Lag Screw Connections

Standard lag screws per ANSI/ASME Standard B18.6.1 could be used in lieu of nails or proprietary self-tapping screws. Lead holes are required in accordance with NDS-2015 Section 12.1.4. 5/16" diameter lag screws are used for this alternative. The shear capacity is based on lag screws that are assumed to be "reduced body diameter" or have threads located in the shear plane.

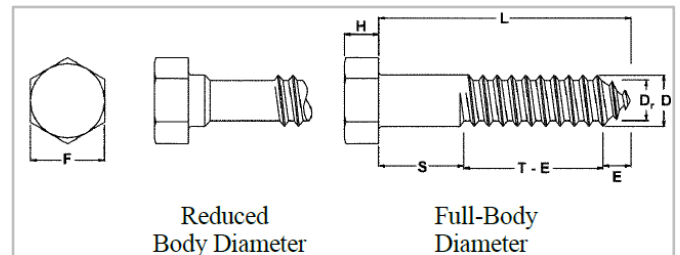

Detail	Description	Lag Screw (D x L), inch	Shear Capacity $C_D=1.0$ (lbs)	Failure Mode	Demand	Required Spacing/No
A	Panel to Panel Connection	5/16x3.50	137.8	IIIs	727 plf	3.6 inch
B	Panel Splice over GLB	5/16x7.0	128.6	IV	727 plf	3.4 inch
C	Panel Connection at Diaphragm Boundary	5/16x7.0	128.6	IV	727 plf	3.4 inch
D	Chord Splice at Midspan	5/16x3.50	248.4	IV	28,032 lbs	15 lags each end each plate