

# Cyclic additional optical true time delay for microwave beam steering with spectral filtering

**Citation for published version (APA):**

Cao, Z., Lu, R., Wang, Q., Tessema, N. M., Jiao, Y., Boom, van den, H. P. A., Tangdiongga, E., & Koonen, A. M. J. (2014). Cyclic additional optical true time delay for microwave beam steering with spectral filtering. *Optics Letters*, 39(12), 3402-3405. <https://doi.org/10.1364/OL.39.003402>

**DOI:**

[10.1364/OL.39.003402](https://doi.org/10.1364/OL.39.003402)

**Document status and date:**

Published: 01/01/2014

**Document Version:**

Accepted manuscript including changes made at the peer-review stage

**Please check the document version of this publication:**

- A submitted manuscript is the version of the article upon submission and before peer-review. There can be important differences between the submitted version and the official published version of record. People interested in the research are advised to contact the author for the final version of the publication, or visit the DOI to the publisher's website.
- The final author version and the galley proof are versions of the publication after peer review.
- The final published version features the final layout of the paper including the volume, issue and page numbers.

[Link to publication](#)

**General rights**

Copyright and moral rights for the publications made accessible in the public portal are retained by the authors and/or other copyright owners and it is a condition of accessing publications that users recognise and abide by the legal requirements associated with these rights.

- Users may download and print one copy of any publication from the public portal for the purpose of private study or research.
- You may not further distribute the material or use it for any profit-making activity or commercial gain
- You may freely distribute the URL identifying the publication in the public portal.

If the publication is distributed under the terms of Article 25fa of the Dutch Copyright Act, indicated by the "Taverne" license above, please follow below link for the End User Agreement:

[www.tue.nl/taverne](http://www.tue.nl/taverne)

**Take down policy**

If you believe that this document breaches copyright please contact us at:

[openaccess@tue.nl](mailto:openaccess@tue.nl)

providing details and we will investigate your claim.

# Cyclic additional optical true time delay for microwave beam steering with spectral filtering

Z. Cao,<sup>1,\*</sup> R. Lu,<sup>1,2</sup> Q. Wang,<sup>1</sup> N. Tessema,<sup>1</sup> Y. Jiao,<sup>1</sup> H. P. A. van den Boom,<sup>1</sup> E. Tangdionga,<sup>1</sup> and A. M. J. Koonen<sup>1</sup>

<sup>1</sup>COBRA Institute, Eindhoven University of Technology, NL 5600 MB Eindhoven, The Netherlands

<sup>2</sup>School of Optoelectronic Information, State Key Laboratory of Electronic Thin Films and Integrated Devices, University of Electronic Science and Technology of China, Chengdu 610054, China

\*Corresponding author: z.cao@tue.nl

Received March 5, 2014; revised April 24, 2014; accepted April 27, 2014;

posted May 1, 2014 (Doc. ID 207742); published June 4, 2014

Optical true time delay (OTTD) is an attractive way to realize microwave beam steering (MBS) due to its inherent features of broadband, low-loss, and compactness. In this Letter, we propose a novel OTTD approach named cyclic additional optical true time delay (CAO-TTD). It applies additional integer delays of the microwave carrier frequency to achieve spectral filtering but without disturbing the spatial filtering (beam steering). Based on such concept, a broadband MBS scheme for high-capacity wireless communication is proposed, which allows the tuning of both spectral filtering and spatial filtering. The experimental results match well with the theoretical analysis. © 2014 Optical Society of America

OCIS codes: (060.5625) Radio frequency photonics; (060.2360) Fiber optics links and subsystems; (350.4010) Microwaves.

<http://dx.doi.org/10.1364/OL.39.003402>

Wireless capacity can be significantly increased based on spatial division multiplexing (SDM) techniques. As a SDM technology, microwave beam steering (MBS) can be used to boost the capacity by focusing the radio signal power in specific directions to increase the signal strength at a receiver. The merits of MBS are that the power efficiency can be largely improved while requiring low computation complexity. Currently, phased antenna arrays (PAAs) are widely used for MBS due to its fast steering capability and compactness [1]. However, beam deformations (also called squint) are observed when a wideband signal is used, which results from the utilization of phase shifters. On the contrary, true time delay- (TTD-) based beam steering potentially eliminates this bandwidth restriction since it provides a frequency independent time delay for each array element. In comparison with traditional electrical TTD, optical true time delay (OTTD) has lower loss, lower complexity, and higher compactness [2–6]. In particular, OTTD can be integrated into radio-over-fiber (RoF) systems which are the key technology for next generation wireless communication systems, with low additional cost. In [7], we have reported our in-house RoF system with OTTD-MBS. A significant sensitivity improvement was observed with 1 Gbps transmission. RoF systems are expected to operate at different frequency bands to support different wireless services, which imply that dynamic spectrum allocation in wireless communications is highly desired. Both spatial filtering and spectral filtering are required in these systems. Motivated by these facts, we propose a novel broadband MBS scheme with tunable microwave filtering based on cyclic additional optical true time delay (CAO-TTD). Compared with traditional OTTD, CAO-TTD introduces negligible additional complexity. By including this low loss extra optical delay, spectral filtering of the RF signal can be achieved.

The principle of OTTD is depicted in Fig. 1. An RF signal is generated by mixing a microwave local oscillator (LO) and a data signal. The RF signal is modulated onto an optical carrier via an optical intensity modulator (IM) and then fed to the optical delay network (ODN). The ODN

includes two branches. The left one is delayed by an OTTD. The modulated optical signal can be expressed as

$$S_o(t) = E_o(1 + \gamma S_e(t)) \exp(j\omega_o t), \quad (1)$$

where  $E_o$  is the amplitude of the optical carrier,  $\omega_o$  is the angular frequency,  $\gamma$  is the modulation depth, and  $S_e(t)$  is the microwave signal. The replica of the optical signal passes through the OTTD with negligible dispersion. The delayed signal can be written as

$$S'_o(t) = E_o(1 + \gamma S_e(t - \tau)) \exp(j\omega_o(t - \tau)), \quad (2)$$

where  $\tau$  denotes the delay. The output optical signals are then converted back to the RF signals via photodiodes (PDs). The detected signal can be written as

$$\begin{aligned} S_d(t) &= \underbrace{2\mu\gamma E_o^2 S_e(t - \tau)}_{\text{signal}}(t) = \mu S'_o(t) S_o(t)^* \\ &= \underbrace{\mu E_o^2}_{\text{DC}} + \underbrace{2\mu\gamma E_o^2 S_e(t - \tau)}_{\text{signal}} + \underbrace{\mu\gamma^2 E_o^2 S_e^2(t - \tau)}_{\text{beating}}, \end{aligned} \quad (3)$$

where  $\mu$  is the responsivity of the engaged PDs. We can see that the signal term and the beating noise term both exist in the detected signal. For microwave signals modulated on optical carriers, the frequency of the beating

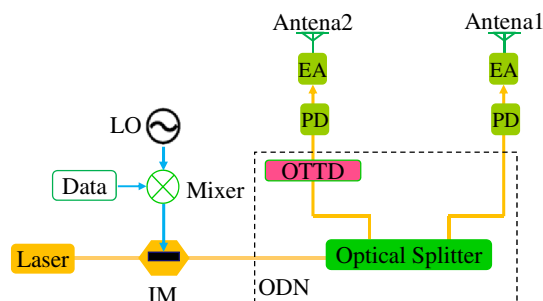

Fig. 1. Principle of optical true time delay (OTTD).

component is usually twice as high as the microwave signals which can be easily filtered out. The DC component will be blocked by the antennas and electrical amplifiers (EAs). Thus the signal broadcasted from the antennas can be written as

$$S_a(t) = \underbrace{2\mu\gamma E_o^2 S_e(t - \tau)}_{\text{signal}}. \quad (4)$$

We can clearly see that the detected microwave signal has been delayed. This will result in the beam steering in the system. Since the microwave delay is exactly the same as the OTTD, in the following discussion, we will analyze the OTTD PAA using the traditional PAA theory. We transform the optical delays into equivalent microwave phase shifts (PSs) which will shape and steer the microwave beam. For a uniform linear array shown in Fig. 2(a), the array factor (AF) with OTTD can be generally expressed as

$$AF(\theta, f) = \sum_{l=0}^{L-1} A_l \exp \left[ j \frac{2\pi f l d}{c} \left( -\sin \theta + \frac{c\tau}{d} \right) \right], \quad (5)$$

where  $\theta$  is the observing angle as shown in Fig. 2(a),  $f$  is the frequency of the microwave signal,  $L$  is the number of element antennas,  $d$  and  $t$  are the distance and time delay between the two adjacent antenna elements, respectively, and  $A_l$  is the amplitude coefficient of the element radiator ( $A_l = 1$  for a uniform linear array). The AF can be further optimized if proper amplitude weights are added. As shown in Fig. 2,  $\tau$  is the propagation delay between two adjacent element antennas. From Eq. (5), we can see that the maximum value of AF is achieved when  $-\sin \theta + c \times \tau/d$  is equal to zero. In other words, the main lobe of the microwave beam points to the angle  $\theta$  when  $\tau$  is equal to  $d \times \sin \theta/c$ . Now, we explore the properties of the proposed CAO-TTD. When the delay is introduced with integer multiple periods ( $mT_p$ ) of the microwave carrier, the AF can be rewritten as

$$AF(\theta, f) = \sum_{l=0}^{L-1} A_l \underbrace{\exp \left[ j \frac{2\pi f l d}{c} \left( -\sin \theta + \frac{c\tau}{d} \right) \right]}_{\text{SpatialFiltering}} \times \underbrace{\exp(j2\pi f l m T_p)}_{\text{SpectralFiltering}}, \quad (6)$$

where  $T_p$  is the period of the microwave carrier, and  $m$  is the number of the integer multiple. First, we only consider the spatial filtering ( $m = 0$ ). When  $\tau$  is equal to  $d \times (\sin \theta/c)$ , the first exponential item (the spatial filtering item) of Eq. (6) obtains its maximum of 1. It means the main lobe directs to the  $\theta$  direction for all frequencies. When the spatial filtering item is determined, the value of AF is only affected by the second exponential function which is essentially a microwave photonics filter. It is clear that the spectral filtering of the received microwave signal in the  $\theta$  direction can be controlled by tuning the integer multiple  $m$ . The spectral filtering operation is illustrated in Fig. 2(b). When the main lobe is obtained, the RF signals from different element antennas can be combined in the space with  $m \times T_p$  difference. The resulting spectral filtering is schematically shown as Fig. 2(b), with the free spectral range (FSR) equal to  $1/(m \times T)$ . Note that the main lobe of the suppressed frequency (instead of the carrier frequency) direct to other directions rather than  $\theta$ .

The optical operation of the additional delays introduces negligible power degradation since the optical loss can be very low. The CAO-TTD can be either a path-switch-based or dispersion-based scheme and the additional delays for spectral filtering will not add significant complexity.

The proof-of-concept experimental setup of the CAO-TTD scheme is shown in Fig. 3. The optical carrier generated from a distributed feedback (DFB) laser is at 1550.016 nm with 3 dBm power. Via a polarization controller (PC), it is fed into a Mach-Zehnder modulator (MZM) with 20 GHz 3 dB bandwidth (BW). The MZM is biased at the quadrature point to obtain the maximum linear dynamic range in the case of intensity modulation. The stimulus microwave sinusoidal signal from a vector network analyzer (VNA) is modulated on the optical carrier. The stimulus signal is swept from 7.5 to 12.5 GHz. The modulated optical signal passes through two paths

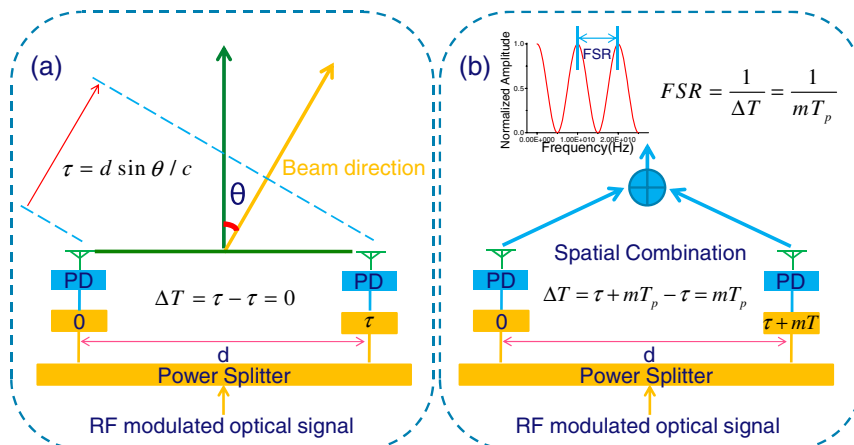

Fig. 2. Principle of microwave phase antenna array based on cyclic additional optical true time delay (CAO-TTD).

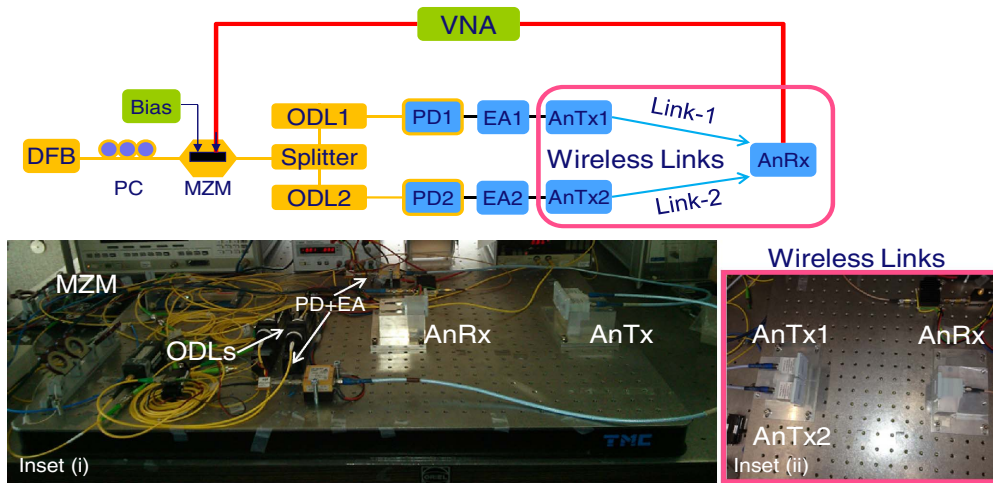

Fig. 3. Proof-of-concept experimental setup of the cyclic additional OTTD scheme.

with two tunable optical delay lines (ODL1/2 in Fig. 3). The ODLs are made by OZ optics (ODL-100) with free space delay and thus the optical length refers to the geometric length. We use ODL1 to compensate the offset delay between the two branches and use ODL2 to adjust the OTTDs for CAO-TTD. The optical signals of the two branches are then detected by two 40 GHz 3 dB BW PDs (PD1/2) for the optical to electrical conversion. The detected radio signals are then fed into two element antennas (AnTx1/2) of the transmitter PAA via two broadband amplifiers with 12.5 GHz 3 dB BW. AnTx1/2 are identically broadband 10 GHz aperture antennas with 5 GHz 3 dB BW. A photo of the experimental setup is shown as inset (i) in Fig. 3. The antenna subsystem are shown as inset (ii) in Fig. 3. AnTx1/2 and AnRx are in a plane (working plane) parallel to the optical table. AnTx1/2 are placed near each other with a 41.5 mm center-to-center distance. The measured mutual coupling between AnTx1 and AnTx2 is less than 20 dB. The microwave beam is steered in the plane parallel to the optical table. The properties of the antenna subsystem are characterized as shown in Fig. 4. The transmission curve (S12) of the engaged antennas is measured as shown in Fig. 4(a). The 5 GHz 3 dB passband is observed. The wireless link connecting AnTx1 and AnRx is named Link-1 as shown in Fig. 3, and the other is named Link-2. A 4 dB received power imbalance (PI) of Link-1 and Link-2 is shown in

Fig. 4(b) which will introduce an imperfect power suppression ratio (PSR). The PSR can be expressed as:

$$PSR = 20 \log_{10} \left( \frac{10^{\frac{PI}{20}} + 1}{10^{\frac{PI}{20}} - 1} \right). \quad (7)$$

The measured 2D far-field pattern (FFA) of the engaged antennas in the working plane is shown in Fig. 4(c). The 3 dB angle width of the 2D FFA is  $70^\circ$  ( $-35^\circ - 35^\circ$ ). The normalized received power of 10 GHz microwave versus optical delays is shown in Fig. 5(a). The peaks with 0, 30, and 60 mm optical length difference and two minimum points with 15 and 45 mm optical lengths are observed. It is clear that the received power is periodic versus the optical delay with a 30 mm periodic length (the wavelength of 10 GHz microwave). Therefore, the cyclic additional integer multiple of 30 mm optical delay will not affect the beam profile at the carrier frequency. Meanwhile, the 30 mm optical delay can cover the whole MBS space. The detailed MBS investigation for such kind of systems can be found in [6]. Now we investigate the CAO-TTD-induced spectral filtering. As shown in Figs. 5(b)–5(c), the transmission curves (S12) for different CAO-TTDs are measured and compared with their corresponding simulated results. The measured curves have been calibrated to eliminate the

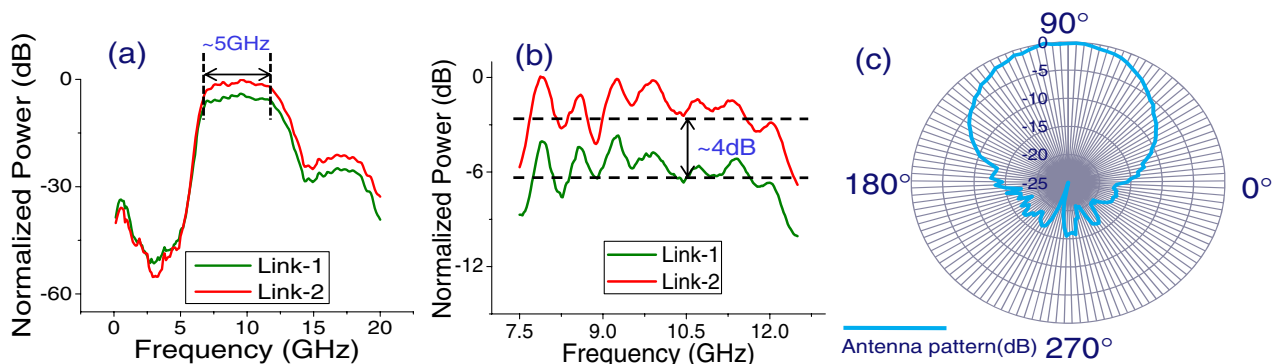

Fig. 4. Measured transmission curves for (a) 0.13–20 GHz and (b) 7.5–12.5 GHz, respectively. (c) The measured 2D far-field pattern of element antennas.

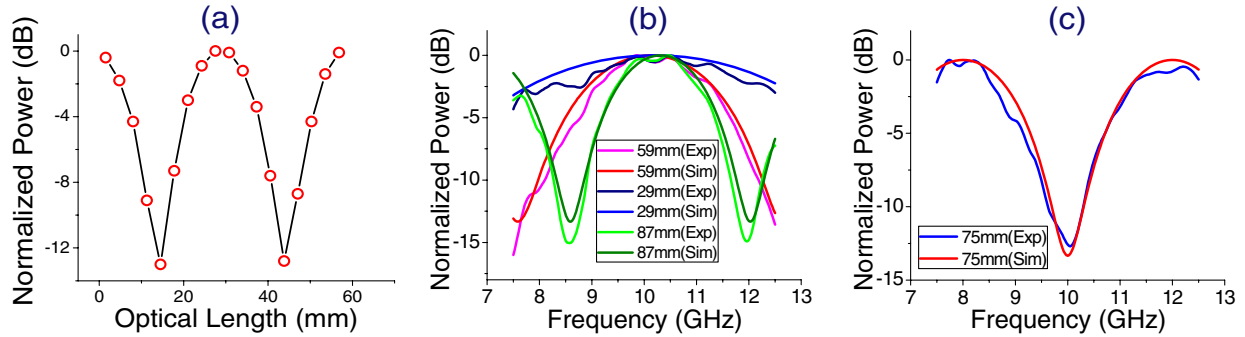

Fig. 5. (a) Measured RF power versus optical delays, (b) bandpass filtering at 10 GHz, and (c) bandstop filtering at 10 GHz.

frequency ripples of the two wireless links. The measured and simulated curves are then normalized at their max values. Since the residual ripples of the measured curves exist, for some comparison sets, the measured curves are a little lower than the simulated ones. In general, good matching between the measured and simulated results is observed. The PSRs for both Figs. 5(b) and 5(c) are around  $-13$  dB, which exhibits a very good agreement with Eq. (7). The bandpass filtering with different optical delays (thus with different FSRs) are shown in Fig. 5(b). As the optical delay increases, the passband and FSR are both suppressed as indicated in Eq. (6.) This exhibits good configurability for spectral allocations. Three sets of CAO-TTDs with 29, 59, and 87 mm optical delay are employed. These delays are chosen close to the integer multiple of the microwave carrier wavelength (30 mm). Therefore, the power of microwave carrier (10 GHz) is not affected by the cyclic additional optical delay as shown in Fig. 5(b). Such a periodic feature is also demonstrated for the bandstop filtering. As shown in Fig. 5(a), the 15 mm optical delay introduces a minimum point at the microwave carrier (10 GHz). Then the minimum point is observed at 10 GHz again as shown in Fig. 5(c) with a 60 mm cyclic additional delay.

To conclude this Letter, a novel broadband MBS with tunable spectral filtering using cyclic additional OTTD is

proposed and experimentally investigated. With high energy efficiency and tunable spectral filtering, we believe that the proposed CAO-TTD is attractive for future wireless communications, especially in the context of RoF networks.

This work is supported by The Netherlands Organization for Scientific Research (NWO) under the project grant Smart Optical-Wireless In-home Communication Infrastructure (SOWICI).

## References

1. R. Mailloux, *Phased Array Antenna Handbook* (Artech House, 2005).
2. W. Ng, A. A. Walston, G. L. Tangonan, J. J. Lee, I. L. Newberg, and N. Bernstein, *J. Lightwave Technol.* **9**, 1124 (1991).
3. O. Raz, S. Barzilay, R. Rotman, and M. Tur, *J. Lightwave Technol.* **26**, 2774 (2008).
4. I. Frigyes and A. J. Seeds, *IEEE Trans. Microwave Theor. Tech.* **43**, 2378 (1995).
5. B. Vidal, J. L. Corral, and J. Marti, *IEEE Microw. Wirel. Compon. Lett.* **13**, 238 (2003).
6. J. Capmany, B. Ortega, and D. Pastor, *J. Lightwave Technol.* **24**, 201 (2006).
7. Z. Cao, F. Li, H. P. A. van den Boom, E. Tangdiongga, and A. M. J. Koonen, in *European Conference and Exhibition on Optical Communication (ECOC)* (2013), pp. 1–3.