

Operation & Maintenance Manual

BULLDOZER

D85EX -15

D85PX -15

SERIAL NUMBERS D85EX-10250 and up
D85PX- 1109

NOTICE

Komatsu has Operation & Maintenance Manuals written in some other languages . If a foreign language manual is necessary , contact your local distributor for availability .

WARNING

Unsafe use of this machine may cause serious injury or Death. Operators and maintenance personnel must read this manual before operating or maintaining this machine. This manual should be kept near the machine for reference and periodically reviewed by all personnel who will come into contact with it .

KOMATSU

FOREWORD

CALIFORNIA

Proposition 65 Warning

Diesel engine exhaust and some of its constituents are known to the State of California to cause cancer, birth defects, and other reproductive harm.

CALIFORNIA

Proposition 65 Warning

Battery posts, terminals and related accessories contain lead and lead compounds, chemicals known to the State of California to cause cancer and birth defects or other reproductive harm.

Wash hands after handling.

FOREWORD

This manual provides rules and guidelines which will help you use this machine safely and effectively. The precautions in this manual must be followed at all times when performing operation and maintenance. Most accidents are caused by the failure to follow fundamental safety rules for the operation and maintenance of machines. Accidents can be prevented by knowing beforehand conditions that may cause a hazard when performing operation and maintenance.



WARNING

Operators and maintenance personnel must always do as follows before beginning operation or maintenance.

- Always be sure to read and understand this manual thoroughly before performing operation and maintenance.
- Read the safety messages given in this manual and the safety labels affixed to the machine thoroughly and be sure that you understand them fully.

Keep this manual in the storage location for the operation and maintenance manual given below, and have all personnel read it periodically.

If this manual has been lost or has become dirty and cannot be read, request a replacement manual immediately from Komatsu or your Komatsu distributor.

If you sell the machine, be sure to give this manual to the new owners together with the machine.

Komatsu delivers machines that comply with all applicable regulations and standards of the country to which it has been shipped. If this machine has been purchased in another country or purchased from someone in another country, it may lack certain safety devices and specifications that are necessary for use in your country. If there is any question about whether your product complies with the applicable standards and regulations of your country, consult Komatsu or your Komatsu distributor before operating the machine.

Location to keep operation & maintenance manual
In door pocket inside of cab door

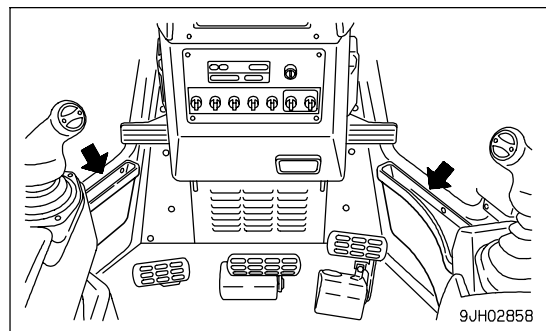

EMISSION CONTROL WARRANTY

EMISSION CONTROL WARRANTY STATEMENT (APPLIES TO CANADA ONLY)

1. Produits garantis

Komatsu Agrico (France) s.r.l. Company, Komatsu Mining Systems Inc. and Komatsu Ltd. Corporation (collectively "Komatsu") produce and/or market products under the trademarks of Komatsu, Dresser, Ingersoll Rand and Gehl. This emission warranty applies to new tractors bearing the Komatsu name installed in these products and used in Canada in machines designed for industrial self-propelled use. This warranty applies to the equipment produced on or after January 1, 2000. This warranty will be administered by Komatsu distributor in Canada.

2. Couverture

Komatsu warrants that, if not purchased, and only subsequent purchases that the equipment is covered under applicable laws and regulations at the time of sale by Komatsu, and all U.S. and Canadian emission regulations applicable at the time of manufacture and that it is free from defects from workmanship or materials which would cause it not to meet these regulations if it had a maximum of 2,000 hours of operation, whichever occurs first, as measured from the date of delivery to the engine or the ultimate purchaser.

3. Limitations

Failures other than those resulting from defects in materials or workmanship are not covered by this warranty. Komatsu is not responsible for failures or damage resulting from what Komatsu determines to be abuse or misuse, including but not limited to operation without adequate cooling or lubrication, use of high-speed, speeding, use of non-approved lubricating, cooling or intake systems, improper storage, starting, or idling for extended periods, maintenance modifications of the engine. Komatsu is also not responsible for failures caused by incorrect fuel or hydraulic determiner circumstances in the field. Komatsu is not responsible for failures or damage due to normal wear and tear, such as battery, and/or other causes that may result from normal use.

KOMATSU IS NOT RESPONSIBLE FOR INCIDENTAL OR CONSEQUENTIAL DAMAGES.

This warranty, together with the express commercial warranties, are the sole warranties of Komatsu. **THERE ARE NO OTHER WARRANTIES, EXPRESS OR IMPLIED, OR OF MERCHANTABILITY OR FITNESS FOR A PARTICULAR PURPOSE.**

GARANTIE SUR LE CONTRÔLE DES ÉMISSIONS

ÉNONCÉ DE GARANTIE SUR LE CONTRÔLE DES ÉMISSIONS (APPLICABLE AU CANADA SEULEMENT)

1. Produits garantis

Komatsu Agrico (France) s.r.l. Company, Komatsu Mining System Inc. et Komatsu Ltd. Corporation (collectivement Komatsu) produisent, vendent et/ou commercialisent des produits portant les noms de marque Komatsu, Dresser, Ingersoll Rand et Gehl. Cette garantie sur les émissions s'applique aux machines portant un moteur portant le nom Komatsu, installées dans ces véhicules et utilisées en France dans des machines conçues pour fonctionner industriellement. Cette garantie s'applique seulement sur les machines produites à partir du 1er janvier 2000. Cette garantie sera administrée par le distributeur de Komatsu au Canada.

2. Couverture

Komatsu garantit que, si elle n'a pas été achetée, et seulement pour des achats ultérieurs, que l'équipement est couvert par la loi applicable à la date de la vente par Komatsu, et toutes les réglementations émanant des gouvernements sur les émissions applicables au moment de la fabrication et qu'il est exempt de défauts de construction ou de matériaux qui causeraient qu'il ne respecte pas les réglementations en vigueur si l'équipement a au maximum 2 000 heures d'opération, whichever occurs first, as measured from the date of delivery to the engine or the ultimate purchaser.

3. Limitations

Les échecs, à l'exception de ceux résultant de défauts de matériaux ou de main d'œuvre, ne sont pas couverts par cette garantie. Komatsu n'est pas responsable pour des échecs ou dommages résultant de ce que Komatsu détermine comme étant de l'abus ou de la négligence, incluant mais non se limitant pas à l'opération sans refroidissement adéquat ou lubrification adéquate, utilisation de lubrifiants, systèmes de refroidissement, systèmes de lubrification ou d'admission non approuvés, utilisation de hauts régimes, utilisation de carburants non recommandés, utilisation de carburants ou d'huile de mauvaise qualité, utilisation prolongée ou utilisation de la machine dans des conditions anormales. De plus, Komatsu n'est pas responsable des dommages causés par l'usage abusif, tel que le démarrage à chaud continué sans l'arrêt de la machine. Komatsu n'est pas responsable des dommages non couverts par les lois, les règlements et toutes autres lois applicables des gouvernements relatifs aux émissions et de tout autre coût d'attente ou autres pertes résultant de l'abus ou de l'usage par la garantie.

KOMATSU N'EST PAS RESPONSABLE DES INCIDENTS OU DOMMAGES CONSÉQUENTS.

Cette garantie, ainsi que les garanties commerciales, sont les seules garanties de Komatsu. **IL N'Y A AUCUNE AUTRE GARANTIE, EXPRESSE OU SANS-ENTENTE, MARC DE COMMERCE OU PROPRIÉTÉ INTELLLECTUELLE PARTICULIÈRE.**

SEEK00906-01 Komatsu Agrico (France) s.r.l. 2016-05-12 3/3

INFORMATION IMPORTANTE SUR LE MOTEUR
 CE MOTEUR EST CONFORME A D'IMPORTANTES REGLES AMERICAINES DE LA CLASSE 20.
 IDENTIFIÉ PAR LA CARACTÉRISTIQUE DE LA MOTEUR, AVEC DES NIVEAUX DE Puissance A 1500-
 1800 RPM EN COMPRESION. CES NIVEAUX DE Puissance SONT EN ESSENCE A 100%
 DE DIESEL.

AVERTISSEMENT
 LES NIVEAUX DE Puissance REVELÉS NE SONT PAS A GARANTIR
 S'ILS NE SONT PAS EN CONFORMITE AVEC LES NIVEAUX DE Puissance
 REVELÉS. LES NIVEAUX REVELÉS NE SONT PAS A GARANTIR
 S'ILS NE SONT PAS EN CONFORMITE AVEC LES NIVEAUX DE Puissance
 REVELÉS.

IMPORTANT ENGINE INFORMATION
 THIS ENGINE COMPLIES TO 2000 AMERICAN SAE REGULATION FOR THE CATEGORY
 20. IDENTIFIED BY THE ENGINE CHARACTERISTICS, WITH POWER LEVELS AT 1500-
 1800 RPM IN COMPRESSION.

WARNING
 POWER LEVELS REVEALED MAY NOT BE GUARANTEED IF THEY DO NOT COMPLY WITH
 REVEALED POWER LEVELS.

<p>ENGINE MODEL</p> <p>DISPLACEMENT</p> <p>MAXIMUM TORQUE</p> <p>MAXIMUM POWER</p> <p>MAXIMUM SPEED</p> <p>MAXIMUM FUEL CONSUMPTION</p> <p>MAXIMUM OIL CONSUMPTION</p> <p>MAXIMUM OIL GRADE</p> <p>MAXIMUM OIL VOLUME</p> <p>MAXIMUM OIL CHANGE INTERVAL</p> <p>MAXIMUM OIL DRAINING INTERVAL</p> <p>MAXIMUM OIL DRAINING VOLUME</p> <p>MAXIMUM OIL DRAINING METHOD</p> <p>MAXIMUM OIL DRAINING POINT</p> <p>MAXIMUM OIL DRAINING TIME</p> <p>MAXIMUM OIL DRAINING TEMPERATURE</p> <p>MAXIMUM OIL DRAINING PRESSURE</p> <p>MAXIMUM OIL DRAINING FLOW RATE</p> <p>MAXIMUM OIL DRAINING EFFICIENCY</p> <p>MAXIMUM OIL DRAINING CLEANLINESS</p> <p>MAXIMUM OIL DRAINING RESIDUE</p> <p>MAXIMUM OIL DRAINING PARTICULATE</p> <p>MAXIMUM OIL DRAINING METALS</p> <p>MAXIMUM OIL DRAINING ACIDITY</p> <p>MAXIMUM OIL DRAINING WATER</p> <p>MAXIMUM OIL DRAINING SALT</p> <p>MAXIMUM OIL DRAINING ASH</p> <p>MAXIMUM OIL DRAINING SULFUR</p> <p>MAXIMUM OIL DRAINING PHOSPHORUS</p> <p>MAXIMUM OIL DRAINING ZINC</p> <p>MAXIMUM OIL DRAINING COPPER</p> <p>MAXIMUM OIL DRAINING IRON</p> <p>MAXIMUM OIL DRAINING NICKEL</p> <p>MAXIMUM OIL DRAINING CHROMIUM</p> <p>MAXIMUM OIL DRAINING MANGANESE</p> <p>MAXIMUM OIL DRAINING MOLYBDENUM</p> <p>MAXIMUM OIL DRAINING BARIUM</p> <p>MAXIMUM OIL DRAINING CALCIUM</p> <p>MAXIMUM OIL DRAINING SODIUM</p> <p>MAXIMUM OIL DRAINING POTASSIUM</p> <p>MAXIMUM OIL DRAINING CHLORINE</p> <p>MAXIMUM OIL DRAINING FLUORINE</p> <p>MAXIMUM OIL DRAINING BROMINE</p> <p>MAXIMUM OIL DRAINING IODINE</p> <p>MAXIMUM OIL DRAINING SILICON</p> <p>MAXIMUM OIL DRAINING ALUMINUM</p> <p>MAXIMUM OIL DRAINING ZINC</p> <p>MAXIMUM OIL DRAINING COPPER</p> <p>MAXIMUM OIL DRAINING IRON</p> <p>MAXIMUM OIL DRAINING NICKEL</p> <p>MAXIMUM OIL DRAINING CHROMIUM</p> <p>MAXIMUM OIL DRAINING MANGANESE</p> <p>MAXIMUM OIL DRAINING MOLYBDENUM</p> <p>MAXIMUM OIL DRAINING BARIUM</p> <p>MAXIMUM OIL DRAINING CALCIUM</p> <p>MAXIMUM OIL DRAINING SODIUM</p> <p>MAXIMUM OIL DRAINING POTASSIUM</p> <p>MAXIMUM OIL DRAINING CHLORINE</p> <p>MAXIMUM OIL DRAINING FLUORINE</p> <p>MAXIMUM OIL DRAINING BROMINE</p> <p>MAXIMUM OIL DRAINING IODINE</p> <p>MAXIMUM OIL DRAINING SILICON</p> <p>MAXIMUM OIL DRAINING ALUMINUM</p>	<p>ENGINE MODEL</p> <p>DISPLACEMENT</p> <p>MAXIMUM TORQUE</p> <p>MAXIMUM POWER</p> <p>MAXIMUM SPEED</p> <p>MAXIMUM FUEL CONSUMPTION</p> <p>MAXIMUM OIL CONSUMPTION</p> <p>MAXIMUM OIL GRADE</p> <p>MAXIMUM OIL VOLUME</p> <p>MAXIMUM OIL CHANGE INTERVAL</p> <p>MAXIMUM OIL DRAINING INTERVAL</p> <p>MAXIMUM OIL DRAINING VOLUME</p> <p>MAXIMUM OIL DRAINING METHOD</p> <p>MAXIMUM OIL DRAINING POINT</p> <p>MAXIMUM OIL DRAINING TIME</p> <p>MAXIMUM OIL DRAINING TEMPERATURE</p> <p>MAXIMUM OIL DRAINING PRESSURE</p> <p>MAXIMUM OIL DRAINING FLOW RATE</p> <p>MAXIMUM OIL DRAINING EFFICIENCY</p> <p>MAXIMUM OIL DRAINING CLEANLINESS</p> <p>MAXIMUM OIL DRAINING RESIDUE</p> <p>MAXIMUM OIL DRAINING PARTICULATE</p> <p>MAXIMUM OIL DRAINING METALS</p> <p>MAXIMUM OIL DRAINING ACIDITY</p> <p>MAXIMUM OIL DRAINING WATER</p> <p>MAXIMUM OIL DRAINING SALT</p> <p>MAXIMUM OIL DRAINING ASH</p> <p>MAXIMUM OIL DRAINING SULFUR</p> <p>MAXIMUM OIL DRAINING PHOSPHORUS</p> <p>MAXIMUM OIL DRAINING ZINC</p> <p>MAXIMUM OIL DRAINING COPPER</p> <p>MAXIMUM OIL DRAINING IRON</p> <p>MAXIMUM OIL DRAINING NICKEL</p> <p>MAXIMUM OIL DRAINING CHROMIUM</p> <p>MAXIMUM OIL DRAINING MANGANESE</p> <p>MAXIMUM OIL DRAINING MOLYBDENUM</p> <p>MAXIMUM OIL DRAINING BARIUM</p> <p>MAXIMUM OIL DRAINING CALCIUM</p> <p>MAXIMUM OIL DRAINING SODIUM</p> <p>MAXIMUM OIL DRAINING POTASSIUM</p> <p>MAXIMUM OIL DRAINING CHLORINE</p> <p>MAXIMUM OIL DRAINING FLUORINE</p> <p>MAXIMUM OIL DRAINING BROMINE</p> <p>MAXIMUM OIL DRAINING IODINE</p> <p>MAXIMUM OIL DRAINING SILICON</p> <p>MAXIMUM OIL DRAINING ALUMINUM</p>
------------------------------------------------------------------------------------------------------------------------------------------------------------------------------------------------------------------------------------------------------------------------------------------------------------------------------------------------------------------------------------------------------------------------------------------------------------------------------------------------------------------------------------------------------------------------------------------------------------------------------------------------------------------------------------------------------------------------------------------------------------------------------------------------------------------------------------------------------------------------------------------------------------------------------------------------------------------------------------------------------------------------------------------------------------------------------------------------------------------------------------------------------------------------------------------------------------------------------------------------------------------------------------------------------------------------------------------------------------------------------------------------------------------------------------------------------------------------------------------------------------------------------------------------------------------------------------------------------------------------------------------------------------------------------------------------------------------------------------------------------------------------------------------------------------------------------------------------------------------------------------------------------------------------------------------------------------------------------------------------------------------------------------------------------------------------------------------------------------------------------------------------------------------------------------------------------------------------------------------------------	------------------------------------------------------------------------------------------------------------------------------------------------------------------------------------------------------------------------------------------------------------------------------------------------------------------------------------------------------------------------------------------------------------------------------------------------------------------------------------------------------------------------------------------------------------------------------------------------------------------------------------------------------------------------------------------------------------------------------------------------------------------------------------------------------------------------------------------------------------------------------------------------------------------------------------------------------------------------------------------------------------------------------------------------------------------------------------------------------------------------------------------------------------------------------------------------------------------------------------------------------------------------------------------------------------------------------------------------------------------------------------------------------------------------------------------------------------------------------------------------------------------------------------------------------------------------------------------------------------------

MAXIMUM TORQUE

MAXIMUM POWER

MAXIMUM SPEED

MAXIMUM FUEL CONSUMPTION

MAXIMUM OIL CONSUMPTION

MAXIMUM OIL GRADE

MAXIMUM OIL VOLUME

MAXIMUM OIL CHANGE INTERVAL

MAXIMUM OIL DRAINING INTERVAL

MAXIMUM OIL DRAINING VOLUME

MAXIMUM OIL DRAINING METHOD

MAXIMUM OIL DRAINING POINT

MAXIMUM OIL DRAINING TIME

MAXIMUM OIL DRAINING TEMPERATURE

MAXIMUM OIL DRAINING PRESSURE

MAXIMUM OIL DRAINING FLOW RATE

MAXIMUM OIL DRAINING EFFICIENCY

MAXIMUM OIL DRAINING CLEANLINESS

MAXIMUM OIL DRAINING RESIDUE

MAXIMUM OIL DRAINING PARTICULATE

MAXIMUM OIL DRAINING METALS

MAXIMUM OIL DRAINING ACIDITY

MAXIMUM OIL DRAINING WATER

MAXIMUM OIL DRAINING SALT

MAXIMUM OIL DRAINING ASH

MAXIMUM OIL DRAINING SULFUR

MAXIMUM OIL DRAINING PHOSPHORUS

MAXIMUM OIL DRAINING ZINC

MAXIMUM OIL DRAINING COPPER

MAXIMUM OIL DRAINING IRON

MAXIMUM OIL DRAINING NICKEL

MAXIMUM OIL DRAINING CHROMIUM

MAXIMUM OIL DRAINING MANGANESE

MAXIMUM OIL DRAINING MOLYBDENUM

MAXIMUM OIL DRAINING BARIUM

MAXIMUM OIL DRAINING CALCIUM

MAXIMUM OIL DRAINING SODIUM

MAXIMUM OIL DRAINING POTASSIUM

MAXIMUM OIL DRAINING CHLORINE

MAXIMUM OIL DRAINING FLUORINE

MAXIMUM OIL DRAINING BROMINE

MAXIMUM OIL DRAINING IODINE

MAXIMUM OIL DRAINING SILICON

MAXIMUM OIL DRAINING ALUMINUM

ENGINE DATA PLATE - ENGLISH/FRENCH

SAFETY INFORMATION

To enable you to use this machine safely, safety precautions and labels are given in this manual and affixed to the machine to give explanations of situations involving potential hazards and of the methods of avoiding such situations.

Signal words

The following signal words are used to inform you that there is a potential hazardous situation that may lead to personal injury or damage.

In this manual and on machine labels, the following signal words are used to express the potential level of hazard.



Indicates an imminently hazardous situation which, if not avoided, will result in death or serious injury.



Indicates a potentially hazardous situation which, if not avoided, could result in death or serious injury.



Indicates a potentially hazardous situation which, if not avoided, may result in minor or moderate injury. This word is used also to alert against unsafe practices that may cause property damage.

Example of safety message using signal word



When standing up from the operator's seat, always place the parking brake lever and work equipment lock lever in the LOCK position.

If you accidentally touch the control levers when they are not locked, this may cause a serious injury or death.

Other signal words

In addition to the above, the following signal words are used to indicate precautions that should be followed to protect the machine or to give information that is useful to know.

NOTICE

This word is used for precautions that must be taken to avoid actions which could shorten the life of the machine.

REMARKS

This word is used for information that is useful to know.

- Safety labels

Safety labels are affixed to the machine to inform the operator or maintenance worker on the spot when carrying out operation or maintenance of the machine that may involve hazard.

This machine uses "Safety labels using words" and "Safety labels using pictograms" to indicate safety procedures.

Example of safety label using words



Safety labels using pictogram

Safety pictograms use a picture to express a level of hazardous condition equivalent to the signal word. These safety pictograms use pictures in order to let the operator or maintenance worker understand the level and type of hazardous condition at all times. Safety pictograms show the type of hazardous condition at the top or left side, and the method of avoiding the hazardous condition at the bottom or right side. In addition, the type of hazardous condition is displayed inside a triangle and the method of avoiding the hazardous condition is shown inside a circle.



Komatsu cannot predict every circumstance that might involve a potential hazard in operation and maintenance. Therefore, the safety messages in this manual and on the machine may not include all possible safety precautions. If any procedures or actions not specifically recommended or allowed in this manual are used, it is your responsibility to take the necessary steps to ensure safety.

In no event should you engage in prohibited uses or actions described in this manual.

The explanations, values, and illustrations in this manual were prepared based on the latest information available at that time. Continuing improvements in the design of this machine can lead to changes in detail which may not be reflected in this manual. Consult Komatsu or your Komatsu distributor for the latest available information of your machine or for questions regarding information in this manual.

The numbers in circles in the illustrations correspond to the numbers in () in the text. (For example: ① → (1))

INTRODUCTION

This Komatsu machine is designed to be used mainly for the following work:

- Dozing
- Cutting into hard or frozen ground or ditching
- Felling trees, removing stumps
- Pushing
- Ripping

For further details, see "WORK POSSIBLE USING BULLDOZER (PAGE 3-118)".

FRONT/REAR, LEFT/RIGHT DIRECTIONS OF MACHINE

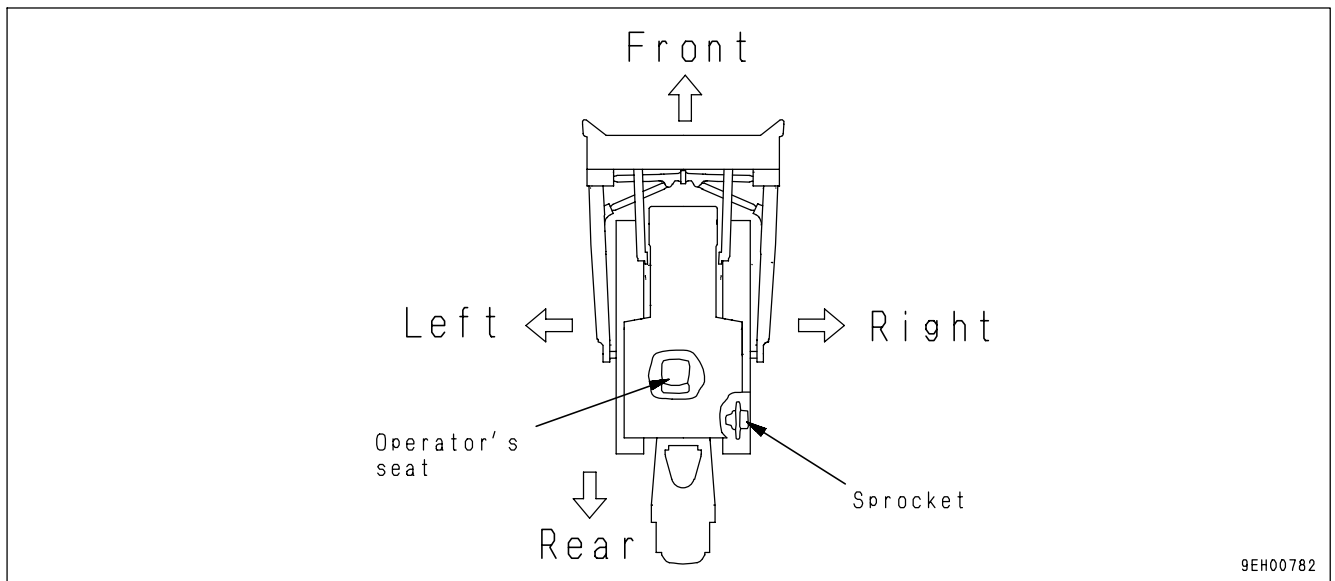

In this manual, the terms front, rear, left, and right refer to the travel direction as seen from the operator's seat when the operator's seat is facing the front and the sprocket is at the rear of the machine.

BREAKING IN THE MACHINE



Your Komatsu machine has been thoroughly adjusted and tested before shipment. However, operating the machine under severe conditions at the beginning can adversely affect the performance and shorten the machine life.

Be sure to break-in the machine for the initial 100 hours (as indicated by the service meter).

During break-in operations, follow the precautions described in this manual.

- Run the engine at idle for 15 seconds after starting it. During this time, do not operate the control levers or fuel control dial.
- Idle the engine for 5 minutes after starting it up.
- Avoid operation with heavy loads or at high speeds.
- Immediately after starting the engine, avoid sudden starts, sudden acceleration, unnecessary sudden stops, and sudden changes in direction.

NECESSARY INFORMATION

When requesting service or ordering replacement parts, please inform your Komatsu distributor of the following items.

PRODUCT IDENTIFICATION NUMBER (PIN), MACHINE SERIAL NO. PLATE

Under the front of the console box on the right side of the operator's seat.
The design of the nameplate differs according to the territory.

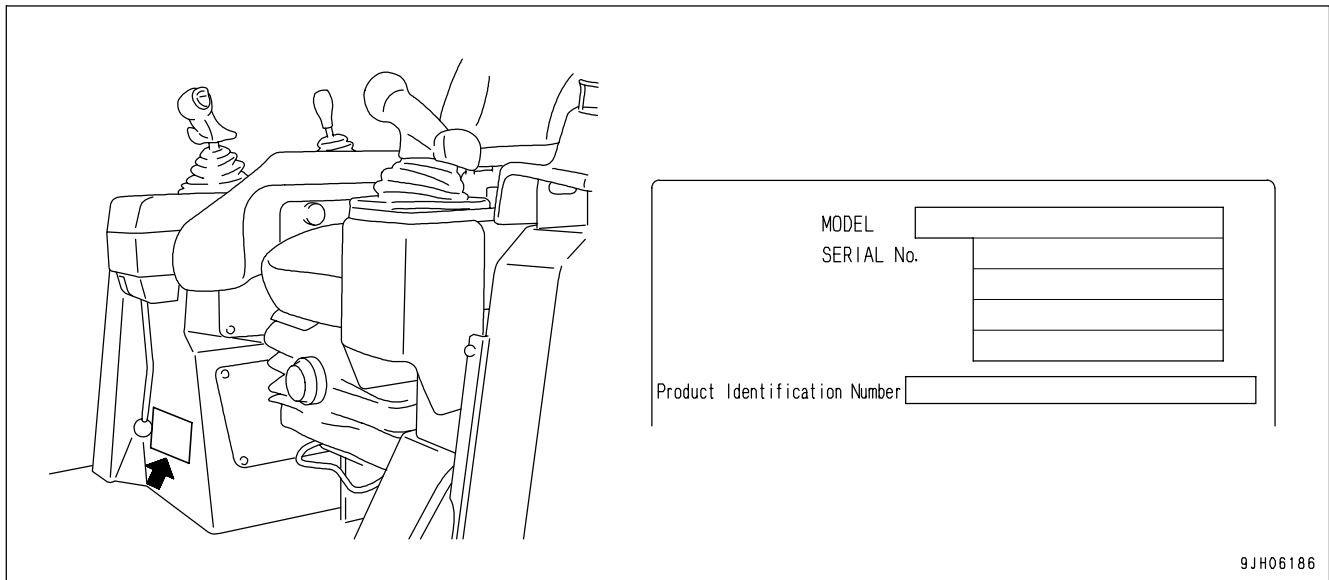

ENGINE SERIAL NO. PLATE

This is at the rear of the starting motor on the rights side of the engine.
(The EMISSION CONTROL INFORMATION LABEL is at the front surface of the engine oil filler on the left side of the engine.)

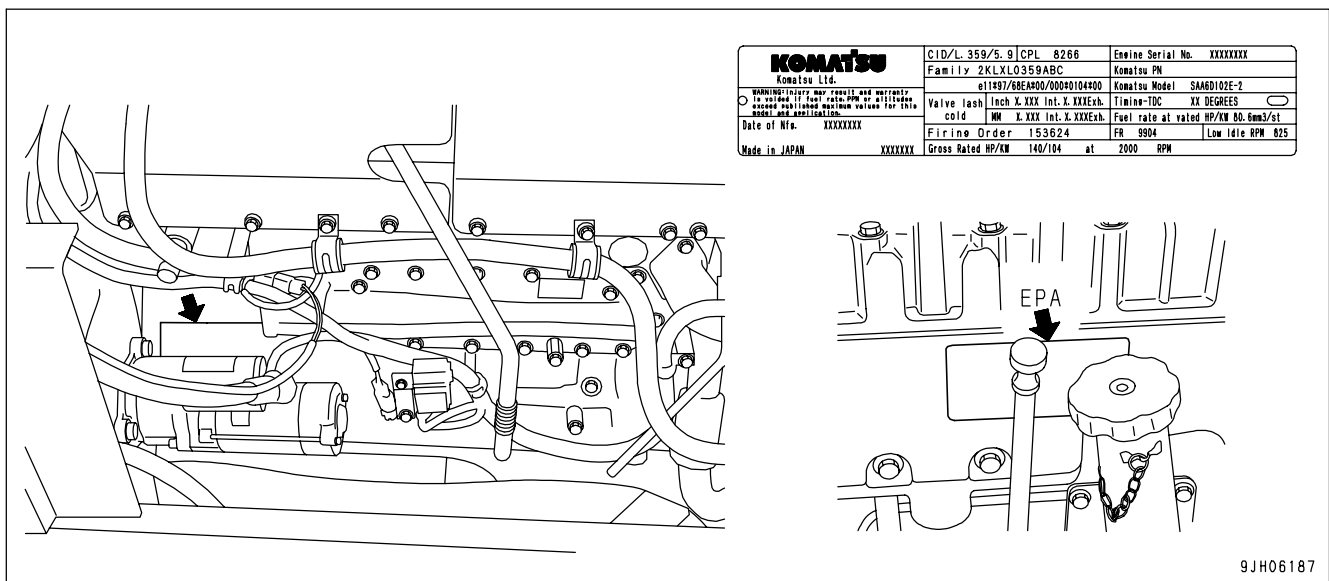

EPA: Environmental Protection Agency, U.S.A.

POSITION OF SERVICE METER

On top of the machine monitor

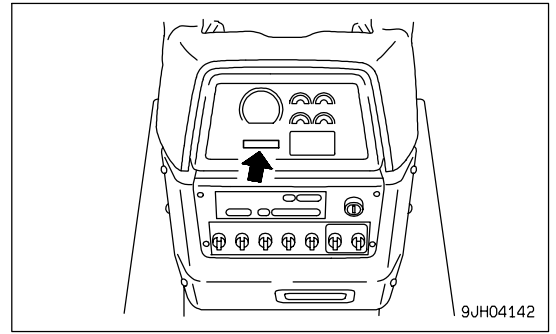

9JH04142

TABLE TO ENTER SERIAL NO. AND DISTRIBUTOR

Machine serial No.	
Engine serial No.	
Product identification number (PIN)	
Distributor name	
Address	-----

Service Personnel	
Phone/Fax	-----

CONTENTS

FOREWORD	1- 1
FOREWORD	1- 2
SAFETY INFORMATION	1- 5
INTRODUCTION	1- 7
FRONT/REAR, LEFT/RIGHT DIRECTIONS OF MACHINE	1- 7
BREAKING IN THE MACHINE	1- 7
NECESSARY INFORMATION	1- 8
PRODUCT IDENTIFICATION NUMBER (PIN), MACHINE SERIAL NO. PLATE	1- 8
ENGINE SERIAL NO. PLATE	1- 8
POSITION OF SERVICE METER	1- 9
TABLE TO ENTER SERIAL NO. AND DISTRIBUTOR	1- 9
SAFETY	2- 1
SAFETY	2- 2
SAFETY LABELS	2- 4
POSITIONS OF SAFETY PICTOGRAMS	2- 4
SAFETY LABELS	2- 5
GENERAL PRECAUTIONS	2- 9
PRECAUTIONS FOR OPERATION	2- 17
BEFORE STARTING ENGINE	2- 17
OPERATION	2- 19
TRANSPORTATION	2- 23
BATTERY	2- 24
TOWING	2- 26
PRECAUTIONS FOR MAINTENANCE	2- 27
OPERATION	3- 1
GENERAL VIEW	3- 2
GENERAL VIEW OF MACHINE	3- 2
GENERAL VIEW OF CONTROLS AND GAUGES	3- 3
EXPLANATION OF COMPONENTS	3- 5
FRONT PANEL	3- 5
SWITCHES	3- 34
CONTROL LEVERS, PEDALS	3- 38
FUSE	3- 45
MAIN POWER CIRCUIT BREAKERS	3- 47
CIRCUIT BREAKER	3- 47
POWER SOURCE	3- 48
CAP WITH LOCK	3- 49
DOOR OPEN LOCK	3- 51
SASH GLASS INTERMEDIATE LOCK	3- 51
DOOR POCKET	3- 52
ASHTRAY	3- 52
TOOL BOX	3- 52
AIR CONDITIONER	3- 53
HEATER, HANDLING	3- 59
CAR STEREO, HANDLING	3- 60
EXTERNAL POWER SOURCE TYPE ENGINE PREHEATING HEATER	3- 68
OPERATION	3- 76
CHECK BEFORE STARTING ENGINE, ADJUST	3- 76
STARTING ENGINE	3- 95

OPERATIONS AND CHECKS AFTER STARTING ENGINE	3-100
STOPPING ENGINE	3-103
MACHINE OPERATION	3-104
SHIFTING GEAR	3-107
SHIFTING BETWEEN FORWARD AND REVERSE	3-111
STEERING MACHINE	3-113
PRECAUTIONS FOR OPERATION	3-115
WORK POSSIBLE USING BULLDOZER	3-118
ADJUSTING POSTURE OF WORK EQUIPMENT	3-120
PARKING MACHINE	3-124
CHECK AFTER FINISHING WORK	3-126
LOCKING	3-126
TIPS FOR LONGER UNDERCARRIAGE LIFE	3-127
TRANSPORTATION	3-130
TRANSPORTATION PROCEDURE	3-130
REMOVAL OF CAB	3-130
INSTALLATION OF CAB	3-131
INSTALLATION OF ROPS	3-131
LOADING, UNLOADING WORK	3-132
METHOD OF LIFTING MACHINE	3-135
PRECAUTIONS FOR TRANSPORTATION	3-136
TRAVELING ON ROADS	3-136
COLD WEATHER OPERATION	3-137
PRECAUTIONS FOR LOW TEMPERATURE	3-137
AFTER COMPLETION OF WORK	3-139
AFTER COLD WEATHER	3-139
LONG-TERM STORAGE	3-140
BEFORE STORAGE	3-140
DURING STORAGE	3-140
AFTER STORAGE	3-140
TROUBLESHOOTING	3-141
AFTER RUNNING OUT OF FUEL	3-141
METHOD OF TOWING MACHINE	3-142
IF BATTERY IS DISCHARGED	3-144
OTHER TROUBLE	3-148
MAINTENANCE	4- 1
GUIDES TO MAINTENANCE	4- 2
OUTLINES OF SERVICE	4- 5
HANDLING OIL, FUEL, COOLANT, AND PERFORMING OIL CLINIC	4- 5
OUTLINE OF ELECTRIC SYSTEM	4- 8
WEAR PARTS	4- 9
WEAR PARTS LIST	4- 9
RECOMMENDED FUEL, COOLANT, AND LUBRICANT	4- 10
USE OF FUEL, COOLANT AND LUBRICANTS ACCORDING TO AMBIENT TEMPERATURE	4- 11
RECOMMENDED BRANDS, RECOMMENDED QUALITY FOR PRODUCTS OTHER THAN KOMATSU GENUINE OIL	4- 12
STANDARD TIGHTENING TORQUES FOR BOLTS AND NUTS	4- 13
TORQUE LIST	4- 13
PERIODIC REPLACEMENT OF SAFETY CRITICAL PARTS	4- 14
SAFETY CRITICAL PARTS	4- 14

MAINTENANCE SCHEDULE CHART -----	4- 16
MAINTENANCE SCHEDULE CHART -----	4- 16
ADJUST INJECTOR -----	4- 18
SERVICE PROCEDURE -----	4- 19
INITIAL 250 HOURS SERVICE (ONLY AFTER THE FIRST 250 HOURS) -----	4- 19
WHEN REQUIRED -----	4- 20
CHECK BEFORE STARTING -----	4- 44
EVERY 250 HOURS SERVICE -----	4- 45
EVERY 500 HOURS SERVICE -----	4- 52
EVERY 1000 HOURS SERVICE -----	4- 56
EVERY 2000 HOURS SERVICE -----	4- 63
EVERY 4000 HOURS SERVICE -----	4- 70
EVERY 8000 HOURS SERVICE -----	4- 74
SPECIFICATIONS -----	5- 1
SPECIFICATIONS -----	5- 2
ATTACHMENTS, OPTIONS -----	6- 1
GENERAL PRECAUTIONS -----	6- 2
PRECAUTIONS RELATED TO SAFETY -----	6- 2
SELECTION OF TRACK SHOE -----	6- 3
METHOD OF SELECTING SHOES -----	6- 3
PROCEDURE FOR SELECTING RIPPER POINT -----	6- 4
HANDLING TRIMMING DOZER -----	6- 5
GENERAL VIEW -----	6- 5
EXPLANATION OF COMPONENTS -----	6- 6
MAINTENANCE -----	6- 7
SPECIFICATIONS -----	6- 11
HANDLING MACHINES EQUIPPED WITH KOMTRAX -----	6- 12
BASIC PRECAUTIONS -----	6- 12
INDEX -----	7- 1

SAFETY

WARNING

Please read and make sure that you fully understand the precautions described in this manual and the safety labels on the machine. When operating or servicing the machine, always follow these precautions strictly.

SAFETY

Safety Labels	2- 4
Positions of Safety Pictograms	2- 4
Safety Labels	2- 5
 General Precautions	
Safety Rules	2- 9
If Abnormalities are Found	2- 9
Clothing and Personal Protective Items	2- 9
Fire Extinguisher and First Aid Kit	2- 9
Safety Features	2- 9
Keep Machine Clean	2- 10
Inside Operator's Compartment	2- 10
Always Apply Lock when Leaving Operator's Seat	2- 10
Handrails and Steps	2- 11
Mounting and Dismounting	2- 11
No People on Attachments	2- 11
Crushing or cutting prevention	2- 11
Prevention of Burns	2- 12
Fire Prevention	2- 12
Action if Fire Occurs	2- 13
Window Washer Liquid	2- 13
Precautions when using ROPS	2- 13
Precautions for Attachments	2- 14
Unauthorized Modification	2- 14
Safety at Worksite	2- 14
Working on Loose Ground	2- 14
Do not Go Close to High-Voltage Cables	2- 15
Ensure Good Visibility	2- 15
Ventilation for Enclosed Areas	2- 15
Checking Signalman's Signals and Signs	2- 16
Emergency exit from operator's cab	2- 16
Be Careful About Asbestos Dust	2- 16

Precautions for Operation	2- 17
Before Starting Engine	2- 17
Checks Before Starting Engine	2- 17
Precautions when Starting	2- 18
Precautions in Cold Areas	2- 18
Operation	2- 19
Checks Before Operation	2- 19
Precautions for Moving Machine Forward or in Reverse	2- 19
Precautions when Traveling	2- 20
Traveling on Slopes	2- 21
Using Brakes	2- 21
Operate Carefully on Snow	2- 21
Parking Machine	2- 22
Transportation	2- 23
Shipping	2- 23
Battery	2- 24
Battery Hazard Prevention	2- 24
Starting with Booster Cable	2- 25
Towing	2- 26
When Towing	2- 26
Precautions for Maintenance	2- 27
Warning Tag	2- 27
Keep Work Place Clean and Tidy	2- 27
Appoint Leader when Working with Others	2- 27
Stop Engine Before Carrying Out Inspection and Maintenance	2- 28
Two Workers for Maintenance when Engine is Running	2- 29
Proper Tools	2- 29
Handling Accumulator	2- 29
Personnel	2- 30
Attachments	2- 30
Work Under the Machine	2- 30
Noise	2- 30
Precautions when Using Hammer	2- 30
Repair Welding	2- 31
Removing Battery Terminal	2- 31
Precautions when Using High-Pressure Grease to Adjust Track Tension	2- 31
Do not Disassemble Recoil Spring	2- 31
Precaution with High-Pressure Oil	2- 32
Precaution for High Fuel Pressure	2- 32
Handling High-Pressure Hoses	2- 32
Precaution for High Voltage	2- 32
Waste Material	2- 33
Maintenance for Air Conditioner	2- 33
Compressed Air	2- 33
Periodic Replacement of Safety Critical Parts	2- 33

SAFETY LABELS

The following warning signs and safety labels are used on this machine.

- Be sure that you fully understand the correct position and content of labels.
- To ensure that the content of labels can be read properly, be sure that they are in the correct place and always keep them clean. When cleaning them, do not use organic solvents or gasoline. These may cause the labels to peel off.
- There are also other labels in addition to the warning signs and safety labels. Handle those labels in the same way.
- If the labels are damaged, lost, or cannot be read properly, replace them with new ones. For details of the part numbers for the labels, see this manual or the actual label, and place an order with Komatsu distributor.

POSITIONS OF SAFETY PICTOGRAMS

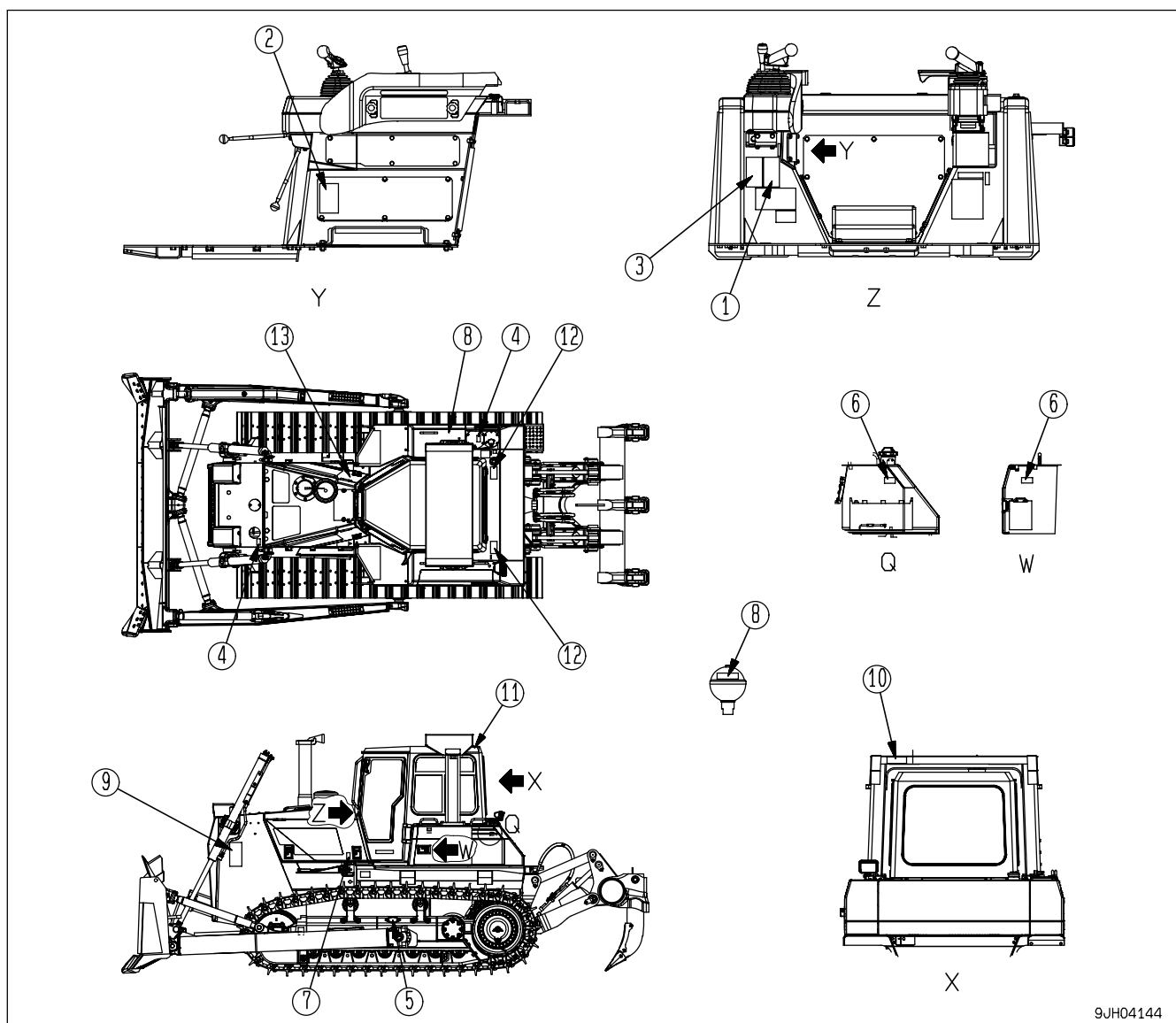

SAFETY LABELS

(1) Caution for operation, inspection, and maintenance
(09651-A0641)

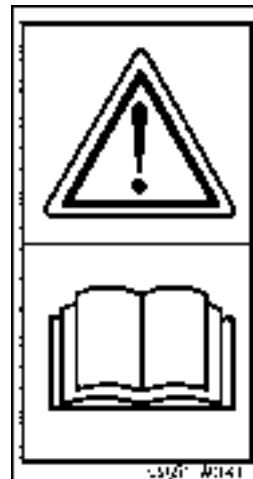

Warning !

Read manual before operation, maintenance, disassembly, assembly and transportation

(2) Caution when traveling in reverse (09802-13000)

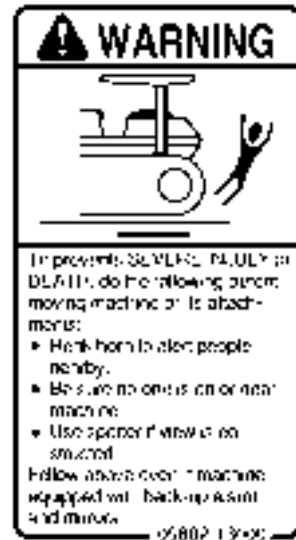

To prevent SERIOUS INJURY or DEATH, do the following when moving machine or its attachments:

- Warn horn to alert people nearby.
- Be sure no one is on or near machine.
- Use operator view as directed.

Follow advice over machine equipped with back-up assist and mirror.

(3) Warning for leaving operator's seat (09654-B0641)



Sign indicates a hazard of unexpected moving of stopped machine

Lower working device to ground, move safety lever to lock position and take engine key with you before leaving machine

(4) Warning for hot water hazard (09653-A0481)



Never remove the cap when the engine is at operating (high) temperature. Steam or high temperature oil blowing up from the radiator or hydraulic tank will cause personal injury and/or burns.

Never remove the radiator cap or hydraulic tank oil filler when cooling water or hydraulic oil is at high temperatures.

(5) Caution when adjusting track tension (09657-A0881)
 Safety label is attached to the back side of the inspection cover of the track frame.



Sign indicates a hazard of flying plug from track adjuster that could cause injury.

Rear manual for safe and proper handling.

(6) Precautions for handling electric wires (09808-A0881)

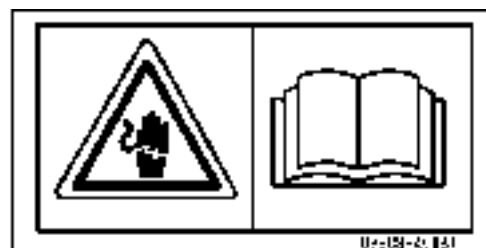

Sign indicates an electric hazard from handling the cable.

Read manual for safe and proper handling.

(7) Caution for engine running (09667-A0481)



Sign indicates a hazard of rotating parts such as belt.

Turn off before inspection and maintenance.

(8) Caution for handling accumulator (09659-A057B)



There is the hazard of explosion causing injury.

Do not disassemble the accumulator, make holes in it, weld it, cut it, hit it, roll it or bring it near flame.

(9) Caution for approach when machine moving (09806-B1683)

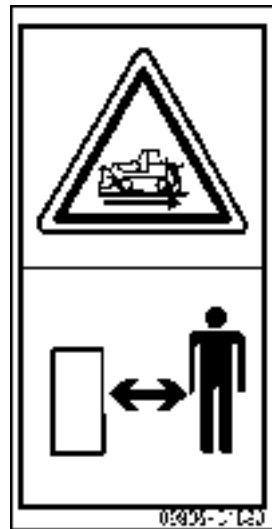

Sign indicates a hazard of being run over by moving equipment

Keep a safe distance from equipment when it is moving.

(10) ROPS (09620-B2000)

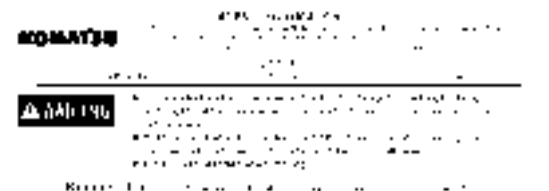

(11) FOPS (09620-C2000)

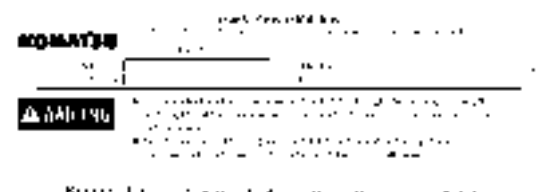

(12) Roll-over precautions (09805-C0881)



Sign indicates a hazard of falling.

Do not stand in this place here.

(13) Jump start prohibited (09842-A0481)



Start the engine only after sitting down in the operator's seat.

Do not attempt to start the engine by short-circuiting the engine starting circuit. Such an act may cause a serious bodily injury or fire.

GENERAL PRECAUTIONS

SAFETY RULES

- Only trained and authorized personnel can operate and maintain the machine.
- Follow all safety rules, precautions and instructions in this manual when operating or performing maintenance on the machine.
- If you are not feeling well, or if you are under the influence of alcohol or medication, your ability to safely operate or repair your machine may be severely impaired, putting yourself and everyone else on your job site in danger.
- When working with another operator or with the person on the worksite traffic duty, discuss the content of the operation beforehand and use the determined signals when carrying out the operation.

IF ABNORMALITIES ARE FOUND

If you find any problems in the machine during operation or maintenance (noise, vibration, smell, incorrect gauges, smoke, oil leakage, etc., or any abnormal display on the warning devices or monitor), report to the person in charge and have the necessary action taken. Do not operate the machine until the problem has been corrected.

CLOTHING AND PERSONAL PROTECTIVE ITEMS

- Do not wear loose clothing and accessories. There is a hazard that they may catch on control levers or other protruding parts.
- If you have long hair and it hangs out from your hard hat, there is a hazard that it may get caught up in the machine, so tie your hair up and be careful not to let it get caught.
- Always wear a hard hat and safety shoes. If the nature of the work requires it, wear safety glasses, mask, gloves, ear plugs, and safety belt when operating or maintaining the machine.
- Check that all protective equipment functions properly before using it.

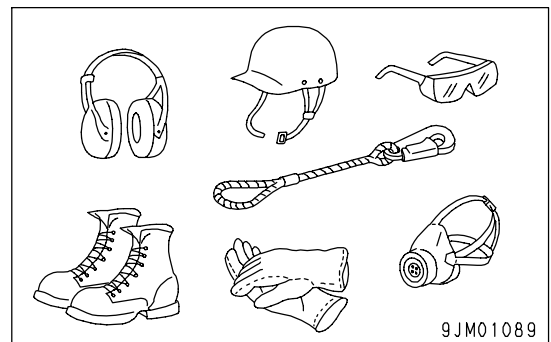

FIRE EXTINGUISHER AND FIRST AID KIT

Always follow the precautions below to prepare for action if any injury or fire should occur.

- Be sure that fire extinguishers have been provided and read the labels to ensure that you know how to use them in emergencies.
- Carry out periodic inspection and maintenance to ensure that the fire extinguisher can always be used.
- Provide a first aid kit in the storage point. Carry out periodic checks and add to the contents if necessary.

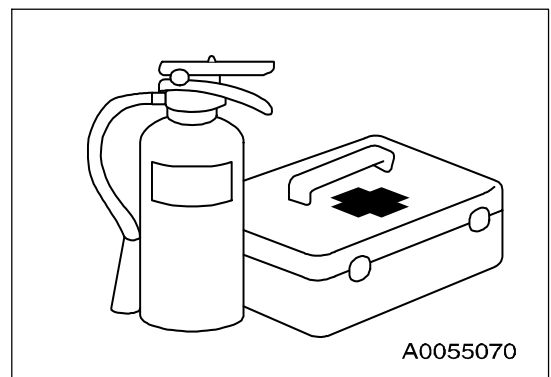

SAFETY FEATURES

- Be sure that all guards, covers and mirrors are in their proper position. Have guards and covers repaired immediately if they are damaged.
- Understand the method of use of safety features and use them properly.
- Never remove any safety features. Always keep them in good operating condition.

KEEP MACHINE CLEAN

- If water gets into the electrical system, there is a hazard that it will cause malfunctions or misoperation. Do not use water or steam to wash the electrical system (sensors, connectors).
- If inspection and maintenance is carried out when the machine is still dirty with mud or oil, there is a hazard that you will slip and fall, or that dirt or mud will get into your eyes. Always keep the machine clean.

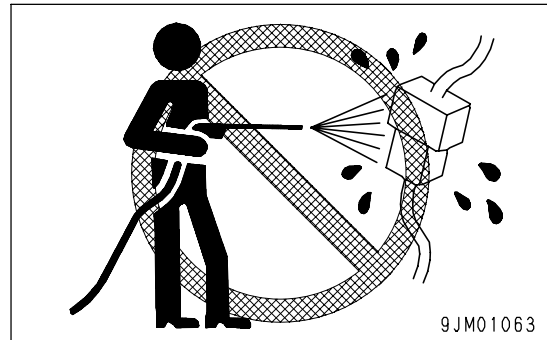
**INSIDE OPERATOR'S COMPARTMENT**

- When entering the operator's compartment, always remove all mud and oil from the soles of your shoes. If you operate the pedal with mud or oil affixed to your shoes, your foot may slip and this may cause a serious accident.
- Do not leave parts or tools lying around the operator's compartment.
- Do not stick suction pads to the window glass. Suction pads act as a lens and may cause fire.
- Do not use cellular telephones inside the operator's compartment when driving or operating the machine.
- Never bring any dangerous objects such as flammable or explosive items into the operator's compartment.

ALWAYS APPLY LOCK WHEN LEAVING OPERATOR'S SEAT

- Before standing up from the operator's seat, lower the work equipment completely to the ground, set work equipment lock lever and parking brake lever securely to the LOCK position, then stop the engine.

If you accidentally touch the levers when they are not locked, there is a hazard that the machine may suddenly move and cause serious injury or property damage.

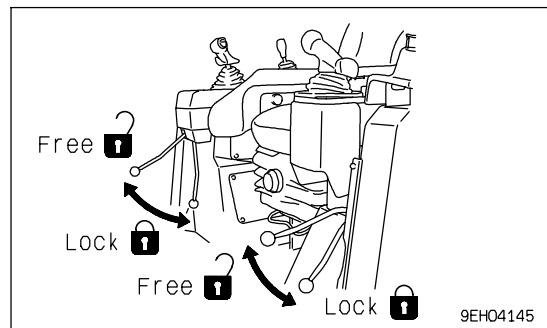

- When leaving the machine, always lower the work equipment completely to the ground, set work equipment lock lever and parking brake lever securely to the LOCK position, then stop the engine. Use the key to lock all the equipment. Always remove the key, take it with you, and keep it in the specified place.

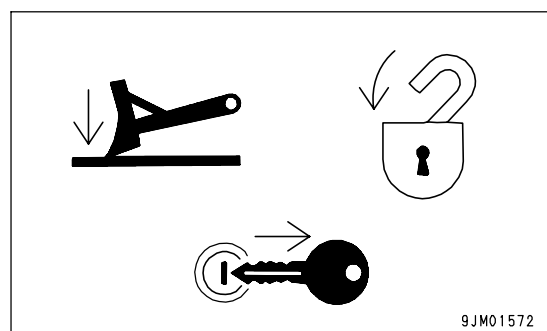

HANDRAILS AND STEPS

To prevent personal injury caused by slipping or falling off the machine, always do as follows.

- Use the parts marked by arrow A in the diagrams when getting on or off the machine.
Never use the parts marked by arrow B when getting on or off the machine. Use them only when moving along the top of the track or when checking or carrying out maintenance inside the side cover, or when filling the tank with oil.
- Never jump on or off the machine. In particular, never get on or off a moving machine. This may cause serious injury.

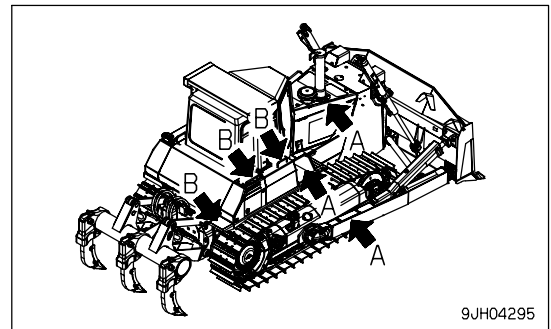
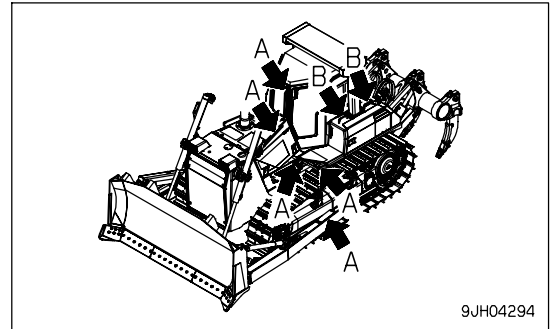

- To ensure safety, always face the machine and maintain three-point contact (both feet and one hand, or both hands and one foot) with the handrails and steps (including the track shoe) to ensure that you support yourself.
- Do not grip the control levers, or work equipment lock lever when getting on or off the machine.
- Never climb on the engine hood or covers where there are no non-slip pads.
- Before getting on or off the machine, check the handrails and steps (including the track shoe). If there is any oil, grease, or mud on the handrails or steps (including the track shoe), wipe it off immediately. Always keep these parts clean. Repair any damage and tighten any loose bolts.
- Do not get on or off the machine while holding tools in your hand.

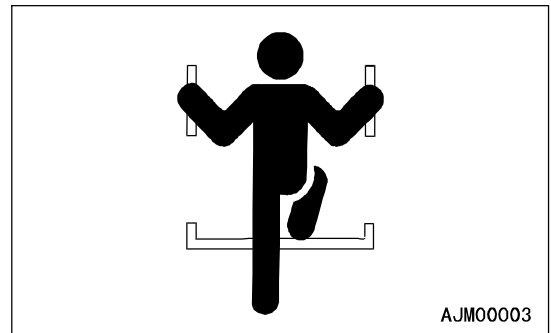

MOUNTING AND DISMOUNTING

- Never jump on or off the machine. Never get on or off a moving machine.
- If the machine starts to move when there is no operator on the machine, do not jump on to the machine and try to stop it.

NO PEOPLE ON ATTACHMENTS

Never let anyone ride on the work equipment, or other attachments. There is a hazard of falling and suffering serious injury.

CRUSHING OR CUTTING PREVENTION

The clearance around the work equipment will change according to the movement of the link. If you get caught, this may lead to serious personal injury. Do not allow anyone to approach any rotating or telescoping part.

PREVENTION OF BURNS**Hot coolant**

- To prevent burns from hot water or steam spurting out when checking or draining the coolant, wait for the water to cool to a temperature where it is possible to touch the radiator cap by hand before starting the operation. Even when the coolant has cooled down, loosen the cap slowly to relieve the pressure inside the radiator before removing the cap.

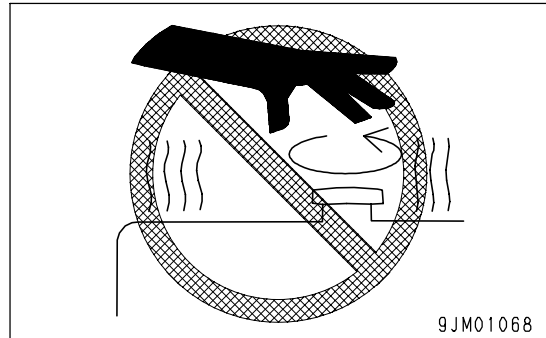
**Hot oil**

- To prevent burns from hot oil spurting out when checking or draining the oil, wait for the oil to cool to a temperature where it is possible to touch the cap or plug by hand before starting the operation. Even when the oil has cooled down, loosen the cap or plug slowly to relieve the internal pressure before removing the cap or plug.

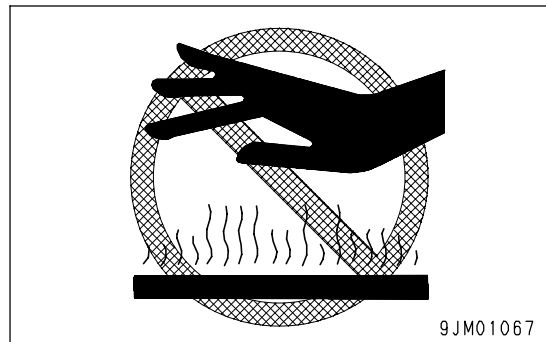
**FIRE PREVENTION****• Fire caused by fuel or oil**

Fuel, oil, antifreeze, and window washer liquid are particularly flammable and can be hazardous. To prevent fire, always observe the following:

- Do not smoke or use any flame near fuel or oil.
- Stop the engine before refueling.
- Do not leave the machine while adding fuel or oil.
- Tighten all fuel and oil caps securely.
- Do not spill fuel on overheated surfaces or on parts of the electrical system.
- Use well-ventilated areas for adding or storing oil and fuel.
- Keep oil and fuel in the determined place and do not allow unauthorized persons to enter.
- After adding fuel or oil, wipe up any spilled fuel or oil.
- When carrying out grinding or welding work on the chassis, move any flammable materials to a safe place before starting.
- When washing parts with oil, use a non-flammable oil. Diesel oil and gasoline may catch fire, so do not use them.
- Put greasy rags and other flammable materials into a safe container to maintain safety at the work place.
- Do not weld or use a cutting torch to cut any pipes or tubes that contain flammable liquids.

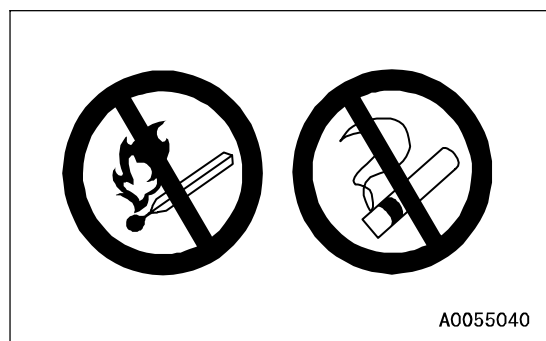
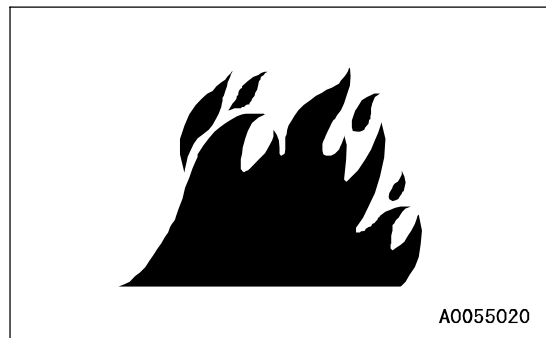
**• Fire caused by accumulation of flammable material.**

Remove any dry leaves, chips, pieces of paper, dust, or any other flammable materials accumulated or affixed around the engine, exhaust manifold, muffler, or battery, or inside the undercovers.

- **Fire coming from electric wiring**

Short circuits in the electrical system can cause fire.

- Always keep electric wiring connections clean and securely tightened.
- Check the wiring every day for looseness or damage. Tighten any loose connectors or wiring clamps. Repair or replace any damaged wiring.

- **Fire coming from hydraulic line**

Check that all the hose and tube clamps, guards, and cushions are securely fixed in position.

If they are loose, they may vibrate during operation and rub against other parts. This may lead to damage to the hoses, and cause high-pressure oil to spurt out, leading to fire damage or serious injury.

- **Explosion caused by lighting equipment**

- When checking fuel, oil, battery electrolyte, window washer fluid, or coolant, always use lighting with anti-explosion specifications. If such lighting equipment is not used, there is danger of explosion that may cause serious injury.
- When taking the electrical power for the lighting from the machine itself, follow the instructions in this manual.

ACTION IF FIRE OCCURS

If a fire occurs, escape from the machine as follows.

- Turn the start switch OFF to stop the engine.
- Use the handrails and steps to get off the machine.

WINDOW WASHER LIQUID

Use an ethyl alcohol base washer liquid.

Methyl alcohol base washer liquid may irritate your eyes, so do not use it.

PRECAUTIONS WHEN USING ROPS (Roll Over Protective Structure)

Install ROPS when carrying out operations in places where there is danger of the machine rolling over or where there is danger of falling rocks, such as in mines and quarries.

- If ROPS is installed, do not remove it when operating the machine.
- ROPS is installed to protect the operator when machine rolls over. When machine rolls over, ROPS supports its weight and absorbs its impact energy.
- If ROPS is modified, its strength may lower. When modifying it, consult your Komatsu distributor.
- If ROPS is deformed by falling objects or by rolling over, its strength lowers and its design functions cannot be maintained. In this case, be sure to ask your Komatsu distributor about repair method.

Even when the ROPS is installed, if you do not fasten your seat belt securely, it cannot protect you properly. Always fasten your seat belt when operating the machine.

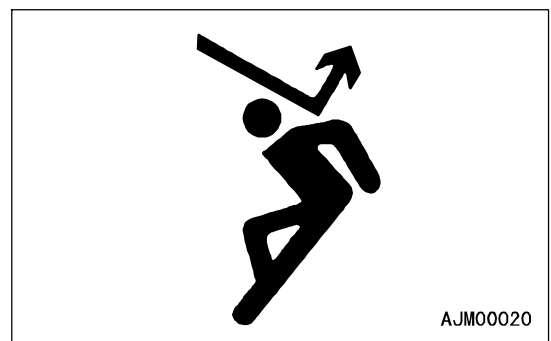

PRECAUTIONS FOR ATTACHMENTS

- When installing optional parts or attachments, there may be problems with safety or legal restrictions. Therefore contact your Komatsu distributor for advice.
- Any injuries, accidents, product failures or other property damages resulting from the use of unauthorized attachments or parts will not be the responsibility of Komatsu.
- When installing and using optional attachments, read the instruction manual for the attachment, and the general information related to attachments in this manual.

UNAUTHORIZED MODIFICATION

Any modification made without authorization from Komatsu can create hazards. Before making a modification, consult your Komatsu distributor.

- Komatsu will not be responsible for any injuries, accidents, product failures or other property damages resulting from modifications made without authorization from Komatsu.

SAFETY AT WORKSITE

Before starting operations, thoroughly check the area for any unusual conditions that could be dangerous.

- When carrying out operations near combustible materials such as thatched roofs, dry leaves or dry grass, there is a hazard of fire, so be careful when operating.
- Check the terrain and condition of the ground at the worksite, and determine the safest method of operation. Do not operate where there is a hazard of landslides or falling rocks.
- If water lines, gas lines, or high-voltage electrical lines may be buried under the worksite, contact each utility and identify their locations. Be careful not to sever or damage any of these lines.
- Take necessary measures to prevent any unauthorized person from entering the operating area.
- In particular, if you need to operate on a road, protect pedestrian and cars by designating a person for worksite traffic duty or by installing fences around the worksite.
- When traveling or operating in shallow water or on soft ground, check the shape and condition of the bedrock, and the depth and speed of flow of the water before starting operations.

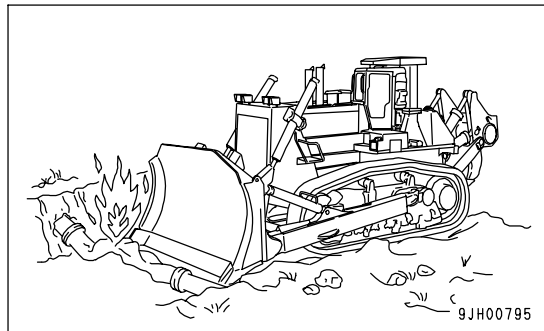
**WORKING ON LOOSE GROUND**

- Avoid traveling or operating your machine too close to the edge of cliffs, overhangs, and deep ditches. The ground may be weak in such areas. If the ground should collapse under the weight or vibration of the machine, there is a hazard that the machine may fall or tip over. Remember that the soil after heavy rain or blasting or after earthquakes is weak in these areas.
- When working on embankments or near excavated ditches, there is a hazard that the weight and vibration of the machine will cause the soil to collapse. Before starting operations, take steps to ensure that the ground is safe and to prevent the machine from rolling over or falling.

DO NOT GO CLOSE TO HIGH-VOLTAGE CABLES

Do not travel or operate the machine near electric cables. There is a hazard of electric shock, which may cause serious personal injury or death. On jobsites where the machine may go close to electric cables, always do as follows.

- Before starting work near electric cables, inform the local power company of the work to be performed, and ask them to take the necessary action.
- Even going close to high-voltage cables can cause electric shock, which may cause serious burns or even death. Always maintain a safe distance (see the table on the right) between the machine and the electric cable. Check with the local power company about safe operating procedure before starting operations.
- To prepare for any possible emergencies, wear rubber shoes and gloves. Lay a rubber sheet on top of the seat, and be careful not to touch the chassis with any exposed part of your body.
- Use a signalman to give warning if the machine approaches too close to the electric cables.
- When carrying out operations near high voltage cables, do not let anyone near the machine.
- If the machine should come too close or touch the electric cable, to prevent electric shock, the operator should not leave the operator's compartment until it has been confirmed that the electricity has been shut off. Also, do not let anyone near the machine.

Voltage of Cables	Safety Distance
100 V - 200 V	Over 2 m (7 ft)
6,600 V	Over 2 m (7 ft)
22,000 V	Over 3 m (10 ft)
66,000 V	Over 4 m (14 ft)
154,000 V	Over 5 m (17 ft)
187,000 V	Over 6 m (20 ft)
275,000 V	Over 7 m (23 ft)
500,000 V	Over 11 m (36 ft)

ENSURE GOOD VISIBILITY

- Check for any persons or obstacles in the area around the machine and check the conditions of the jobsite to ensure that operations and travel can be carried out safely. Always do as follows.
 - Position a signalman if there are areas at the rear of the machine where the visibility is not good.
 - When working in dark places, turn on the working lamp and front lamps installed to the machine, and set up additional lighting in the work area if necessary.
 - Stop operations if the visibility is poor, such as in mist, snow, rain, or dust.

VENTILATION FOR ENCLOSED AREAS

Exhaust fumes from the engine can kill.

- If it is necessary to start the engine within an enclosed area, or when handling fuel, flushing oil, or paint, open the doors and windows to ensure that adequate ventilation is provided to prevent gas poisoning.

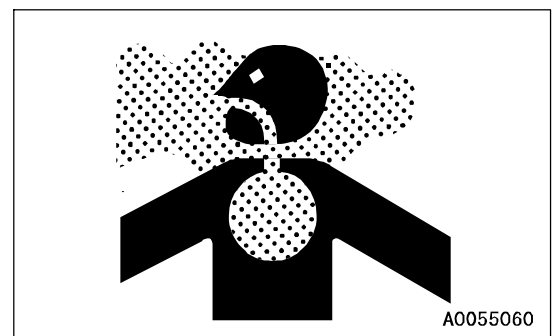

CHECKING SIGNALMAN'S SIGNALS AND SIGNS

- Set up signs to inform of road shoulders and soft ground. If the visibility is not good, position a signalman if necessary. Operators should pay careful attention to the signs and follow the instructions from the signalman.
- Only one signalman should give signals.
- Make sure that all workers understand the meaning of all signals and signs before starting work.

EMERGENCY EXIT FROM OPERATOR'S CAB

Machines equipped with a cab have doors on the left and right sides. If the door on the one side does not open, escape from the door on the other side.

BE CAREFUL ABOUT ASBESTOS DUST

Asbestos dust in the air can cause lung cancer if it is inhaled. There is danger of inhaling asbestos when working on jobsites handling demolition work or work handling industrial waste. Always observe the following.

- Spray water to keep down the dust when cleaning. Do not use compressed air for cleaning.
- If there is danger that there may be asbestos dust in the air, always operate the machine from an upwind position. All workers should use an approved respirator.
- Do not allow other persons to approach during the operation.
- Always observe the rules and regulations for the work site and environmental standards.

This machine does not use asbestos, but there is a danger that imitation parts may contain asbestos, so always use genuine Komatsu parts.

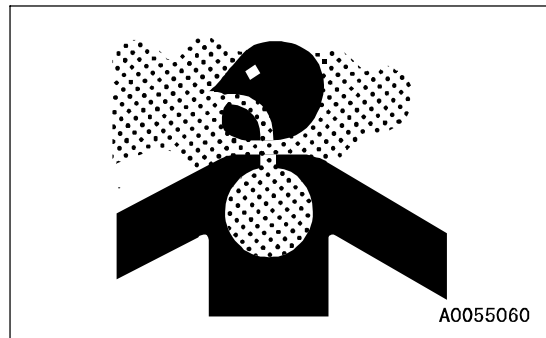

PRECAUTIONS FOR OPERATION

BEFORE STARTING ENGINE

If there is a warning tag hanging from the work equipment control lever, do not start the engine or touch the levers.

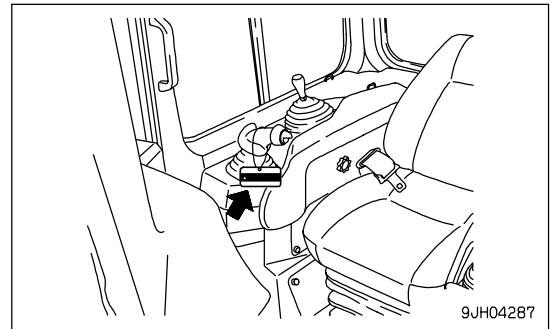

CHECKS BEFORE STARTING ENGINE

Carry out the following checks before starting the engine at the beginning of the day's work.

- Completely remove all flammable materials accumulated around the engine and battery, and remove any dirt from the windows, mirrors, handrails and steps.
- Remove all dirt from the surface of the lens of the front lamps and working lamps, and check that they light up correctly.
- Check the coolant level, fuel level, and oil level in engine oil pan, check for clogging of the air cleaner, and check for damage to the electric wiring.
- Adjust the operator's seat to a position where it is easy to carry out operations, and check that there is no damage or wear to the seat belt or mounting clamps.
- Check the operation of the instruments and gauges, check the angle of the mirror, and check that the control levers are all at the Neutral position.
- When starting the engine, check that the parking brake lever and work equipment lock lever are at the LOCK position.
- Adjust the mirrors so that you can get a good rear-view from the operator's seat.
For the details of adjustment, see "ADJUST MIRROR (PAGE 3-91)".
- Check that there are no persons or obstacles above, below, or in the area around the machine.

PRECAUTIONS WHEN STARTING

- Start and operate the machine only while seated.
- Do not attempt to start the engine by short-circuiting the engine starting circuit. Such an act may cause a serious bodily injury or fire.
- When starting the engine, sound the horn as a warning.
- Do not allow anyone apart from the operator to ride on the machine.

PRECAUTIONS IN COLD AREAS

- Carry out the warming-up operation thoroughly. If the machine is not thoroughly warmed up before the control levers are operated, the reaction of the machine will be slow, and this may lead to unexpected accidents.
- If the battery electrolyte is frozen, do not charge the battery or start the engine with a different power source. There is a hazard that this will ignite the battery and cause the battery to explode. Before charging or starting the engine with a different power source, melt the battery electrolyte and check that there is no leakage of electrolyte before starting.

OPERATION

CHECKS BEFORE OPERATION

When carrying out the checks, move the machine to a wide area where there are no obstructions, and operate slowly. Do not allow anyone near the machine.

- Always fasten your seat belt.
- Check the operation of travel, steering and brake systems, and work equipment control system.
- Check for any problem in the sound of the machine, vibration, heat, smell, or gauges; check also that there is no leakage of oil or fuel.
- If any problem is found, carry out repairs immediately.



PRECAUTIONS FOR MOVING MACHINE FORWARD OR IN REVERSE

- Before travelling, check again that there is no one in the surrounding area, and that there are no obstacles.
- Before travelling, sound the horn to warn people in the area.
- Always operate the machine only when seated.
- Do not allow anyone apart from the operator to ride on the machine.
- Check that the backup alarm (alarm buzzer when machine travels in reverse) works properly.
- Fix the operator's compartment doors and windows in the closed position securely.
- If there is an area to the rear of the machine which cannot be seen, position a signal person. Take special care not to hit other machines or people when turning or swinging the machine.

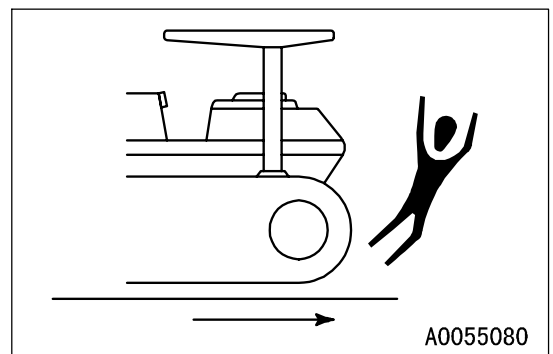

Always be sure to carry out the above precautions even when the machine is equipped with mirrors.

PRECAUTIONS WHEN TRAVELING

- When traveling on flat ground, keep the work equipment 40 to 50 cm (16 to 20 in) high above the ground.
- When traveling on rough ground, travel at low speed and do not operate the steering suddenly. There is danger that the machine may turn over. The work equipment may hit the ground surface and cause the machine to lose its balance, or may damage the machine or structures in the area.

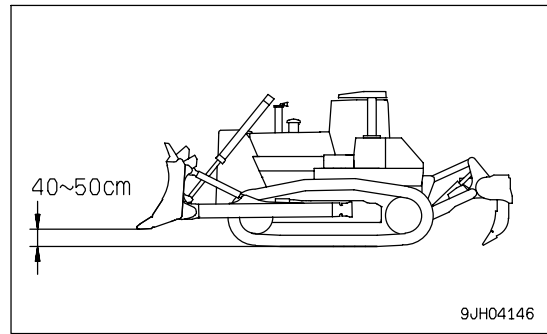

- Avoid traveling over obstacles when possible. If the machine has to travel over an obstacle, keep the work equipment close to the ground and travel at low speed. Never travel over obstacles which make the machine tilt strongly to one side.
- When traveling or carrying out operations, always keep a safe distance from people, structures, or other machines to avoid coming into contact with them.
- When passing over bridges or structures, check first that the structure is strong enough to support the weight of the machine. When traveling on public roads, check first with the relevant authorities and follow their instructions.

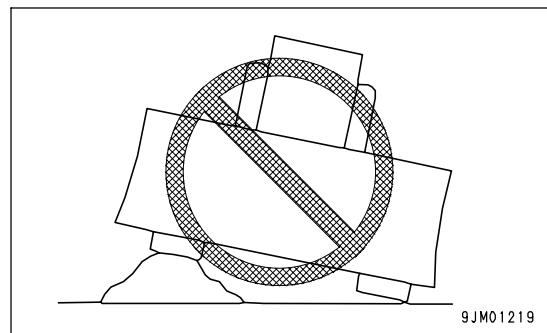

- When operating in tunnels, under bridges, under electric wires, or other places where the height is limited, operate slowly and be extremely careful not to let the machine body or work equipment hit anything.
- Do not approach the edge of a cliff carelessly. When dropping soil over a cliff for banking or reclamation, leave soil of one scoop at the edge of the cliff and push it with the next scoop.
- When the machine passes over the top of a hill or when a load is dumped over a cliff, the load is suddenly reduced, and there is danger that the travel speed rises suddenly. To prevent this, lower the travel speed.
- If the machine moves with only either side of the blade loaded, its tail may swing. Take care.

TRAVELING ON SLOPES

To prevent the machine from tipping over or slipping to the side, always do as follows.

- When traveling on slopes, keep the blade approximately 20 to 30 cm (8 to 12 in) above the ground. In case of emergency, quickly lower the blade to the ground to help the machine to stop. Apply the brake and use the engine as a brake, if necessary.
- Always travel straight up or down a slope. Traveling at an angle or across the slope is extremely dangerous.
- Do not turn on slopes or travel across slopes. Always go down to a flat place to change the position of the machine, then travel on to the slope again.
- Travel on grass, fallen leaves, or wet steel plates with low speed. Even with slight slopes there is a hazard that the machine may slip.
- When driving down a slope, never shift gear or place the transmission in neutral. The engine brake cannot be used and this creates a dangerous condition. Always travel downhill in the same speed range as when traveling uphill.
- When turning on a downhill ground, lower the travel speed.

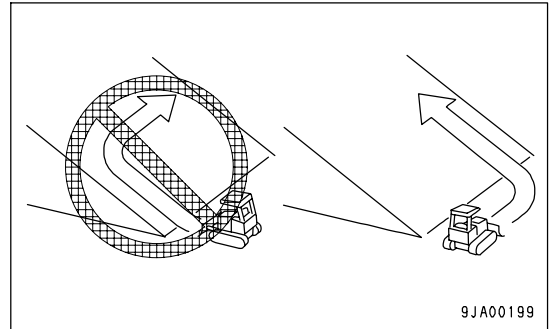

USING BRAKES

- When the machine is traveling, do not rest your foot on the brake pedal. If you travel with your foot resting on the pedal, the brake will always be applied, and this will cause the brakes to overheat and fail.
- Do not depress the brake pedal repeatedly if not necessary. If this is neglected, the brake will be overheated and will not work when required.
- When traveling downhill, use the braking force of the engine.

OPERATE CAREFULLY ON SNOW

- Snow-covered or frozen surfaces are slippery, so be extremely careful when traveling or operating the machine, and do not operate the levers suddenly. Even a slight slope may cause the machine to slip, so be particularly careful when working on slopes.
- With frozen ground surfaces, the ground becomes soft when the temperature rises, and this may cause the machine to tip over or make it impossible for the machine to escape.
- If the machine enters deep snow, there is a hazard that it may tip over or become buried in the snow. Be careful not to leave the road shoulder or to get trapped in a snow drift.
- When clearing snow, the road shoulder and objects placed beside the road are buried in the snow and cannot be seen. There is a hazard of the machine tipping over or hitting covered objects, so always carry out operations carefully.
- When traveling on snow-covered slopes, never apply the brakes suddenly. Reduce the speed and use the engine as a brake while applying the foot brake intermittently (depress the brake intermittently several times). If necessary, lower the blade to the ground to stop the machine.

PARKING MACHINE

- Park the machine on level ground where there is no danger of falling rocks or landslides, or of flooding if the land is low, and lower the work equipment to the ground.

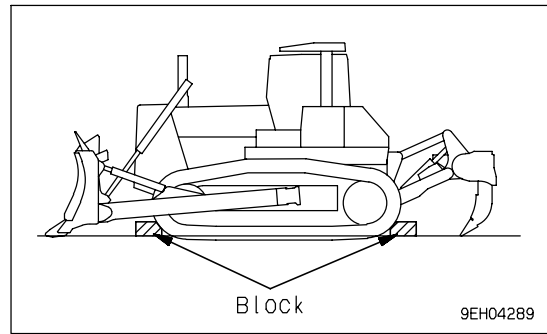

- If it is necessary to park the machine on a slope, set the blocks under the tracks to prevent the machine from moving, then dig the work equipment into the ground.

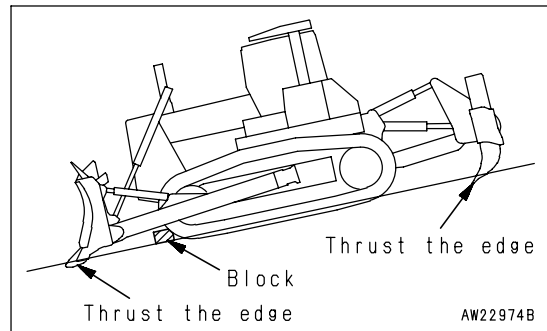

- When leaving the machine, set the work equipment lock lever and parking brake lever to the LOCK position, stop the engine, and use the key to lock all the equipment. Always remove the key and take it with you.

Work equipment posture: See "PARKING MACHINE (PAGE 3-124)".

Locks: See "LOCKING (PAGE 3-126)"

- Always close the door of the operator's compartment.

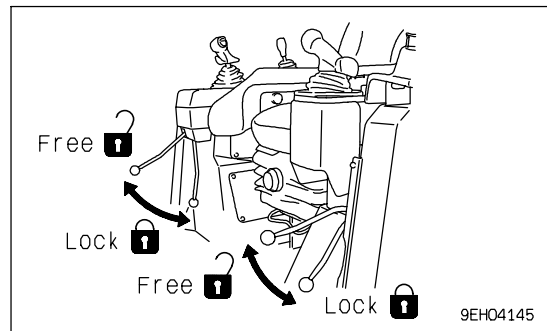

TRANSPORTATION

The machine can be divided into parts for transportation, so when transporting the machine, please contact your Komatsu distributor to have the work carried out.

LOADING AND UNLOADING

When loading or unloading the machine, mistaken operation may bring the hazard of the machine tipping over or falling, so particular care is necessary. Always do as follows.

- Perform loading and unloading on firm, level ground only. Maintain a safe distance from the edge of the road or cliff.
 - Always use ramps of adequate strength. Be sure that the ramps are wide, long, and thick enough to provide a safe loading slope. Take suitable steps to prevent the ramps from moving out of position or coming off.
 - Be sure the ramp surface is clean and free of grease, oil, ice and loose materials. Remove dirt from machine-tracks. On a rainy day, in particular, be extremely careful since the ramp surface is slippery.
 - Run the engine at low speed and travel slowly.
 - When on the ramps, do not operate any lever except for the travel lever.
 - Never correct your steering on the ramps. If necessary, drive off the ramps, correct the direction, then enter the ramps again.
 - The center of gravity of the machine will change suddenly at the joint between the ramps and the track or trailer, and there is danger of the machine losing its balance. Travel slowly over this point.
 - When loading or unloading to an embankment or platform, make sure that it has suitable width, strength, and grade.
 - For machines equipped with a cab, always lock the door after boarding the machine. If this is not done, the door may suddenly open during transportation.
- Refer to "TRANSPORTATION (PAGE 3-130)".

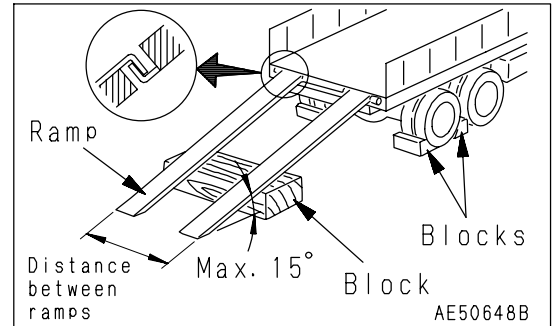

SHIPPING

When shipping the machine on a trailer, do as follows.

- The weight, transportation height, and overall length of the machine differ according to the work equipment, so be sure to confirm the dimensions.
- When passing over bridges or structures on private land, check first that the structure is strong enough to support the weight of the machine. When traveling on public roads, check first with the relevant authorities and follow their instructions.
- For details of the shipping procedure, see "TRANSPORTATION (PAGE 3-130)" in the OPERATION section.

BATTERY

BATTERY HAZARD PREVENTION

Battery electrolyte contains sulphuric acid, and batteries generate flammable hydrogen gas, which may explode. Mistaken handling can lead to serious injury or fire. For this reason, always observe the following precautions.

- When the battery electrolyte is below LOWER LEVEL, don't either use or charge the battery. Otherwise, that may cause explosion. Always carry out periodic checks of the battery electrolyte, and add distilled water up to UPPER LEVEL.

For the method of checking the battery electrolyte, see "CHECK LEVEL OF BATTERY ELECTROLYTE (PAGE 4-48)".

- When working with batteries, always wear safety glasses and rubber gloves.
- Never smoke or use any flame near the battery.

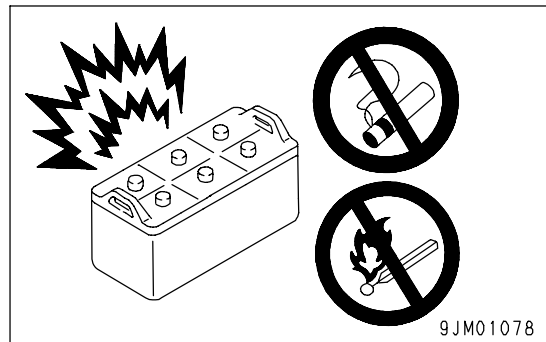

- If you spill acid on your clothes or skin, immediately flush the area with large amount of water.
- If acid gets into your eyes, flush them immediately with large amount of water and seek medical attention.

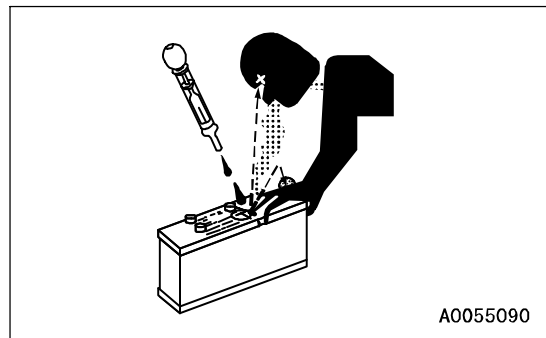

- Before working with batteries, turn the starting switch to the OFF position.

As there is a hazard that sparks will be generated, always do as follows.

- Do not let tools or other metal objects make any contact between the battery terminals. Do not leave tools or other metal objects lying around near the battery.
- Always disconnect the negative (-) terminal (ground side) first when removing the battery; when installing the battery, connect the positive (+) terminal first, and connect the ground last. Tighten the battery terminals securely.
- Tighten the battery terminals securely.
- Flammable hydrogen gas is generated when the battery is charged, so remove the battery from the chassis, take it to a well-ventilated place, and remove the battery caps before charging it.
- Tighten the battery caps securely.
- Install the battery securely to the determined place.

STARTING WITH BOOSTER CABLE

If any mistake is made in the method of connecting the booster cables, it may cause the battery to explode, so always do as follows.

- When starting with a booster cable, carry out the starting operation with two workers (one worker sitting in the operator's seat and the other working with the battery).
- When starting from another machine, do not allow the two machines to touch.
- When connecting the booster cables, turn the starting switch OFF position for both the normal machine and problem machine. There is a hazard that the machine will move when the power is connected.
- Be sure to connect the positive (+) cable first when installing the booster cables. Disconnect the negative (-) cable (ground side) first when removing them.
- When removing the booster cables, be careful not to let the booster cable clips touch each other or to let the clips touch the machine.
- Always wear safety glasses and rubber gloves when starting the engine with booster cables.
- When connecting a normal machine to a problem machine with booster cables, always use a normal machine with the same battery voltage as the problem machine.
- For the procedure of starting the engine with booster cables, see "STARTING ENGINE WITH BOOSTER CABLE (PAGE 3-146)".

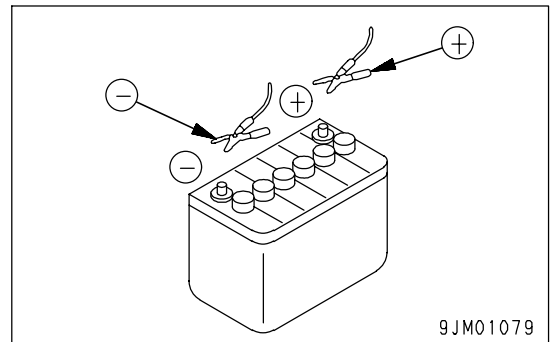
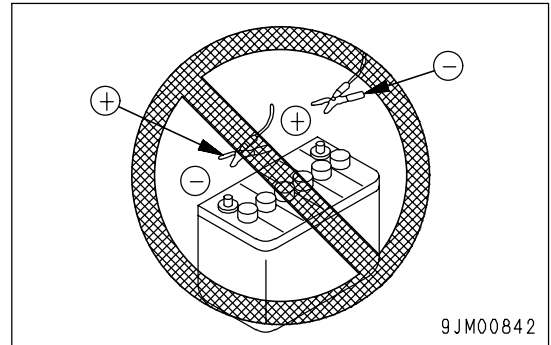

TOWING

WHEN TOWING

Serious injury or death could result if there is any mistake in the selection of wire rope or method of towing a disabled machine.

For towing, see "METHOD OF TOWING MACHINE (PAGE 3-142)".

- Always be sure to check carefully that the capacity of the wire rope used for towing is ample for the weight of the towed machine.
- Never use a wire rope which has cut strands (A), reduced diameter (B), or kinks (C). There is danger that the rope may break during the towing operation.
- Always wear leather gloves when handling wire rope.
- Never tow a machine on a slope.
- During the towing operation, never stand between the towing machine and the machine being towed.
- Move the machine slowly and be sure not to apply any sudden load on the wire rope.

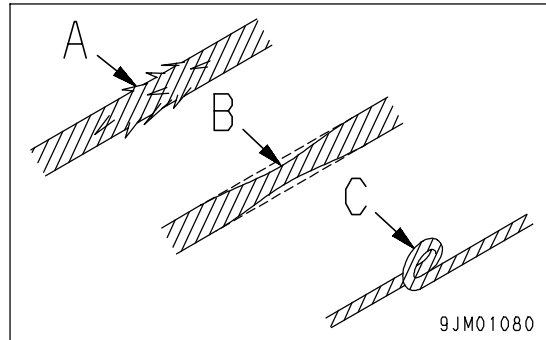

- If the engine stops or the oil pressure in the brake circuit lowers because of a trouble in the hydraulic system, the brake works and the machine cannot move. To move the machine in this case, the oil pressure in the brake circuit must be heightened to the specified level with a special device. Ask your Komatsu distributor.

PRECAUTIONS FOR MAINTENANCE

WARNING TAG

- Always attach the "DO NOT OPERATE" warning tag to the work equipment control lever in the operator's cab to alert others that you are performing service or maintenance on the machine. Attach additional warning tags around the machine if necessary. Warning tag Part No. 09963-03001. Keep the tag in the operation manual pocket.
- When carrying out inspection or maintenance, ALWAYS attach the "DO NOT OPERATE" warning tag to the blade control lever in the operator's cab to alert others that you are working on the machine. Attach additional warning tags around the machine in necessary.

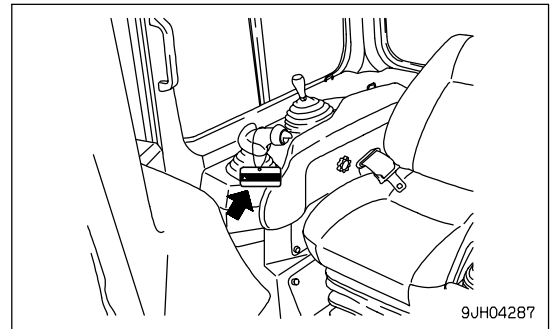

Warning tag Part No. 09963-A1640

This tag is placed in the same case as is this operation and maintenance manual.

- If others start the engine, or touch or operate the work equipment control lever while you are performing service or maintenance, you could suffer serious injury or property damage.



KEEP WORK PLACE CLEAN AND TIDY

- Do not leave hammers or other tools lying around in the work place. Wipe up all grease, oil, or other substances that will cause you to slip. Always keep the work place clean and tidy to enable you to carry out operations safely. If the work place is not kept clean and tidy, there is the danger that you will trip, slip, or fall over and injure yourself.

APPOINT LEADER WHEN WORKING WITH OTHERS

- When repairing the machine or when removing and installing the work equipment, appoint a leader and follow his instructions during the operation. When working with others, misunderstandings between workers can lead to serious accidents.

STOP ENGINE BEFORE CARRYING OUT INSPECTION AND MAINTENANCE

- Stop the machine on firm, level ground.
- Select a place where there is no hazard of landslides, falling rocks, or flooding.
- Lower the work equipment completely to the ground and stop the engine.
- After stopping the engine, operate the work equipment control lever to the RAISE and LOWER positions 2 or 3 times to release the pressure remaining in the hydraulic circuit, then set the work equipment lock lever and Parking brake lever to LOCK position.

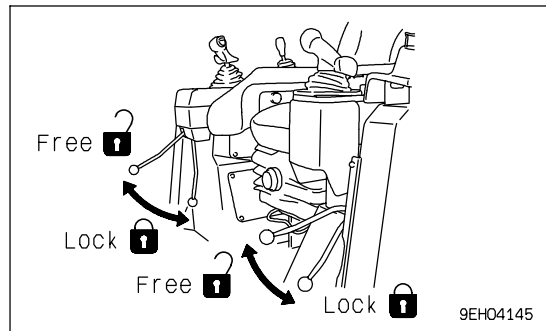
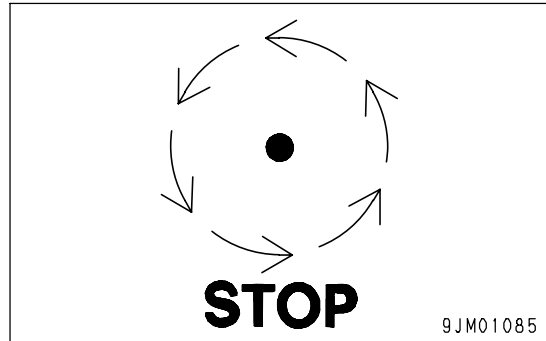

- Put blocks under the track to prevent the machine from moving.

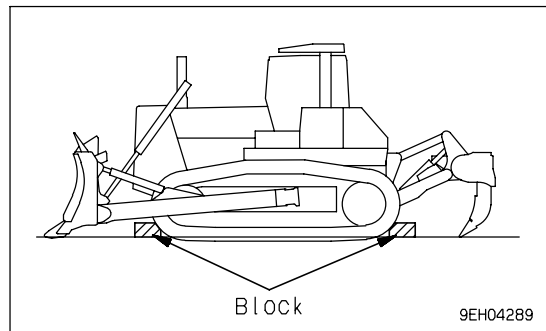

TWO WORKERS FOR MAINTENANCE WHEN ENGINE IS RUNNING

To prevent personal injury, do not carry out maintenance with the engine running. If maintenance must be carried out with the engine running, carry out the operation with at least two workers and do as follows.

- One worker must always sit in the operator’s seat and be ready to stop the engine at any time. All workers must maintain contact with the other workers.
- Place the parking brake lever and work equipment lock lever at the LOCK position to prevent the work equipment from moving.
- When carrying out operations near the fan, fan belt, or other rotating parts, there is a hazard of being caught in the parts, so be careful not to come close.
- Do not touch any control levers. If any control lever must be operated, give a signal to the other workers to warn them to move to a safe place.
- Never drop or insert tools or other objects into the fan or fan belt. Parts may break or be sent flying.

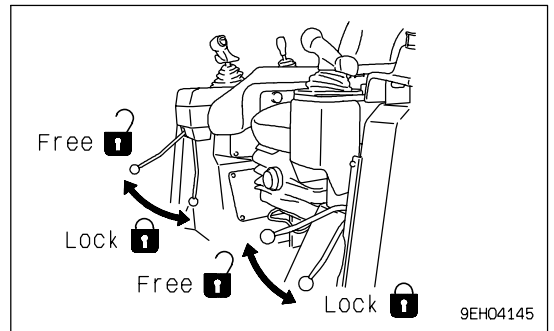
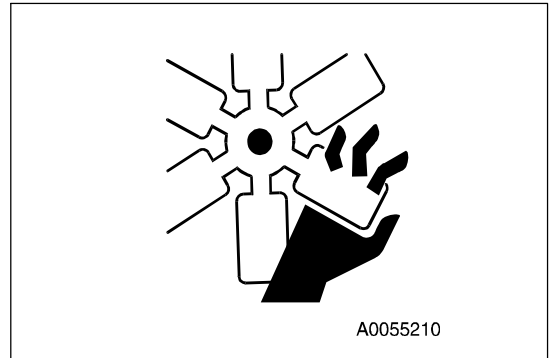

PROPER TOOLS

Use only tools suited to the task and be sure to use the tools correctly. Using damaged, low quality, faulty, makeshift tools or improper use of the tools could cause serious personal injury.

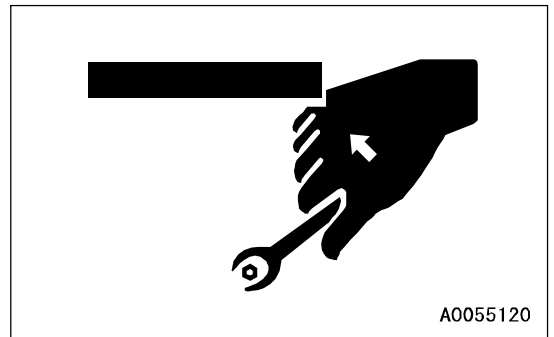

HANDLING ACCUMULATOR

The accumulator is charged with high-pressure nitrogen gas. When handling the accumulator, careless procedure may cause an explosion which could lead to serious injury or property damage. For this reason, always observe the following precautions.

- Do not disassemble the accumulator.
- Do not bring it near flame or dispose of it in fire.
- Do not make holes in it, weld it, or use a cutting torch.
- Do not hit or roll the accumulator, or subject it to any impact.
- When disposing of the accumulator, the gas must be released. Please contact your Komatsu distributor to have this work performed.



PERSONNEL

Do not allow any unauthorized personnel into the area when servicing the machine. If necessary, employ a guard.

ATTACHMENTS

- Appoint a leader before starting removal or installation operations for attachments.
- Place attachments that have been removed from the machine in a stable condition so that they do not fall. And take steps to prevent unauthorized persons from entering the storage area.



WORK UNDER THE MACHINE

- If it is necessary to go under the work equipment or the machine to carry out service and maintenance, support the work equipment and machine securely with blocks and stands strong enough to support the weight of the work equipment and machine.
- It is extremely dangerous to work under the machine if the track shoes are lifted off the ground and the machine is supported only with the work equipment. If any of the control levers is touched by accident, or there is damage occurring to the hydraulic piping, the work equipment or the machine will suddenly drop. This is extremely dangerous. Never work under the work equipment or the machine.

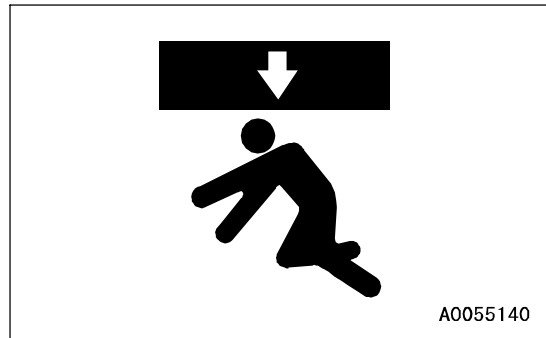

NOISE

When carrying out maintenance of the engine and you are exposed to noise for long periods of time, wear ear covers or ear plugs while working.

If the noise from the machine is too loud, it may cause temporary or permanent hearing problems.

PRECAUTIONS WHEN USING HAMMER

When using a hammer, pins may fly out or metal particles may be scattered. This may lead to serious injury. Always do as follows.

- If hard metal parts such as pins, bucket teeth, cutting edges, or bearings are hit with a hammer, there is a hazard that pieces might be scattered and cause serious personal injury or death. Always wear safety glasses and gloves.
- When hitting pins or bucket teeth, there is a hazard that broken pieces might be sent flying and injure people in the surrounding area. Always check that there is no one in the surrounding area.

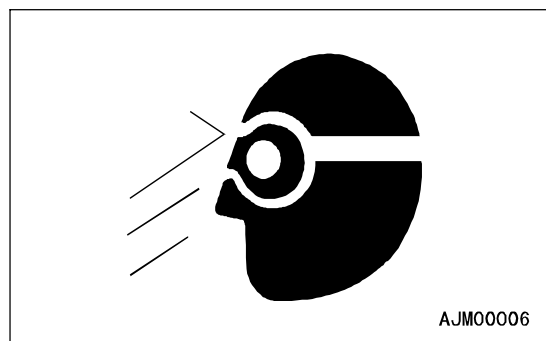

- There is a hazard that the pin hit with strong force may fly out and injure people in the surrounding area.

REPAIR WELDING

Welding operations must always be carried out by a qualified welder and in a place equipped with proper equipment. There is a hazard of gas, fire, or electrocution when carrying out welding, so never allow any unqualified personnel to carry out welding.

REMOVING BATTERY TERMINAL

When repairing the electrical system or when carrying out electrical welding, remove the negative (-) terminal of the battery to prevent the flow of current.

PRECAUTIONS WHEN USING HIGH-PRESSURE GREASE TO ADJUST TRACK TENSION

- Grease is pumped into the track tension adjustment system under high pressure. If the specified procedure for maintenance is not followed when making adjustment, grease drain valve (1) may fly out and cause serious injury or damage.
- When loosening grease drain valve (1) to loosen track tension, never loosen it more than one turn. In doing so, loosen the valve slowly.
- Never put your face, hands, feet, or any other part of your body directly in front of grease drain valve (1).

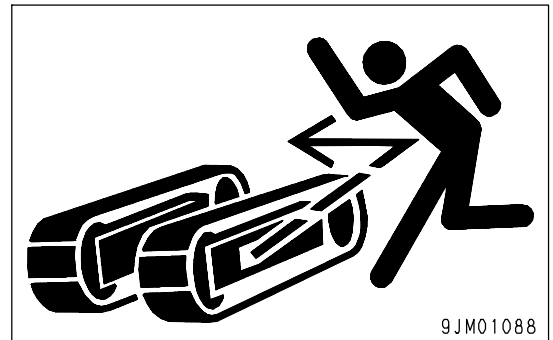
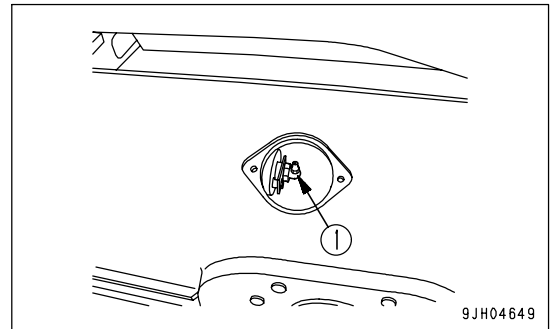
**DO NOT DISASSEMBLE RECOIL SPRING**

Never attempt to disassemble the recoils spring assembly. It contains a spring under high pressure which serves as a shock absorber for the idler. If it is disassembled by mistake, the spring will fly out and cause serious injury. When it becomes necessary to disassemble it, ask your Komatsu distributor to do the work.

PRECAUTION WITH HIGH-PRESSURE OIL

The hydraulic system is always under internal pressure. When inspecting or replacing piping or hoses, always check that the pressure in the hydraulic circuit has been released. If the circuit is still under pressure, it will lead to serious personal injury, so always do as follows.

- Do not carry out inspection or replacement work when the hydraulic system is under pressure.
- If there is any leakage from the piping or hoses, the surrounding area will be wet, so check for cracks in the piping and hoses and for swelling in the hoses.

When carry out inspection, wear safety glasses and leather gloves.

- There is a hazard that high-pressure oil leaking from small holes may penetrate your skin or cause blindness if it contacts your eyes directly. If you are hit by a jet of high-pressure oil and suffer injury to your skin or eyes, wash the place with clean water, and consult a doctor immediately for medical attention.

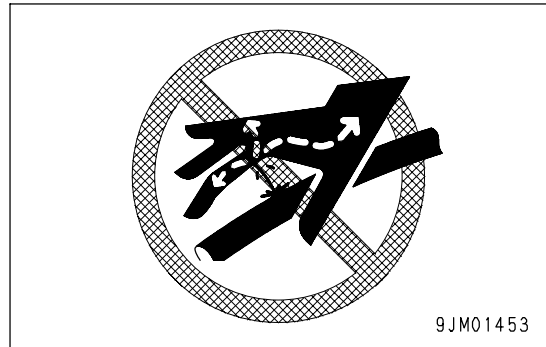
**PRECAUTION FOR HIGH FUEL PRESSURE**

High pressure is generated inside the engine fuel piping when the engine is running. When carrying out inspection or maintenance of the fuel piping system, wait for at least 30 seconds after stopping the engine to let the internal pressure go down before starting inspection or maintenance.

HANDLING HIGH-PRESSURE HOSES

- If oil or fuel leaks from high-pressure hoses, it may cause fire or defective operation, which may lead to serious injury. If any loose bolts are found, stop work and tighten to the specified torque. If any damaged hoses are found, stop operations immediately and contact your Komatsu distributor.

Replace the hose if any of the following problems are found.

- Damaged or leaking hydraulic fitting.
- Frayed or cut covering or exposed reinforcement wire layer.
- Covering swollen in places.
- Twisted or crushed movable portion.
- Foreign material embedded in covering.

PRECAUTION FOR HIGH VOLTAGE

- When the engine is running and immediately after it is stopped, high voltage is generated inside the engine controller and the engine injector, and there is danger of electrocution. Never touch the inside of the controller or the engine injector portion.

If it is necessary to touch the inside of the controller or the engine injector portion, please contact your Komatsu distributor.

WASTE MATERIAL

To prevent pollution, pay careful attention to the method of disposing of waste materials.

- Always put oil drained from your machine in containers. Never drain oil directly onto the ground or dump into the sewage system, rivers, the sea, or lakes.
- Obey appropriate laws and regulations when disposing of harmful objects such as oil, fuel, coolant, solvent, filters, and batteries.

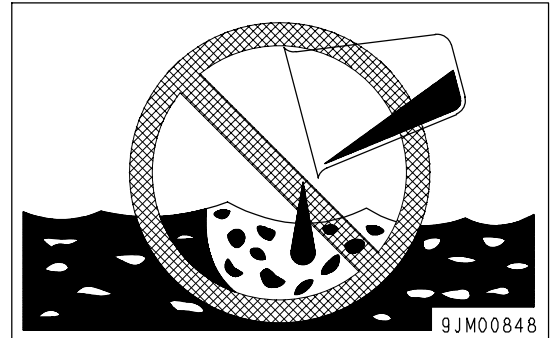
**MAINTENANCE FOR AIR CONDITIONER**

If air conditioner refrigerant gets into your eyes, it may cause blindness; if it touches your skin, it may cause frostbite. Never touch refrigerant.

COMPRESSED AIR

- When carrying out cleaning with compressed air, there is a hazard of serious injury caused by flying particles.
- When using compressed air to clean elements or the radiator, always wear safety glasses, dust mask, gloves, and other protective equipment.

PERIODIC REPLACEMENT OF SAFETY CRITICAL PARTS

- For using the machine safely for an extended period of time, replace safety-critical parts like hoses and seat belts periodically.
Replacement of safety-critical parts: See "PERIODIC REPLACEMENT OF SAFETY CRITICAL PARTS (PAGE 4-14)".
- The material of these components naturally changes over time, and repeated use causes deterioration, wear, and fatigue. As a result, there is a hazard that these components may fail and cause serious injury or death. It is difficult to judge the remaining life of these components from external inspection or the feeling when operating, so always replace them at the specified interval.
- Replace or repair safety-critical parts if any defect is found, even when they have not reached the specified replacement time.

OPERATION

WARNING

Please read and make sure that you understand the SAFETY section before reading this section.

GENERAL VIEW

GENERAL VIEW OF MACHINE

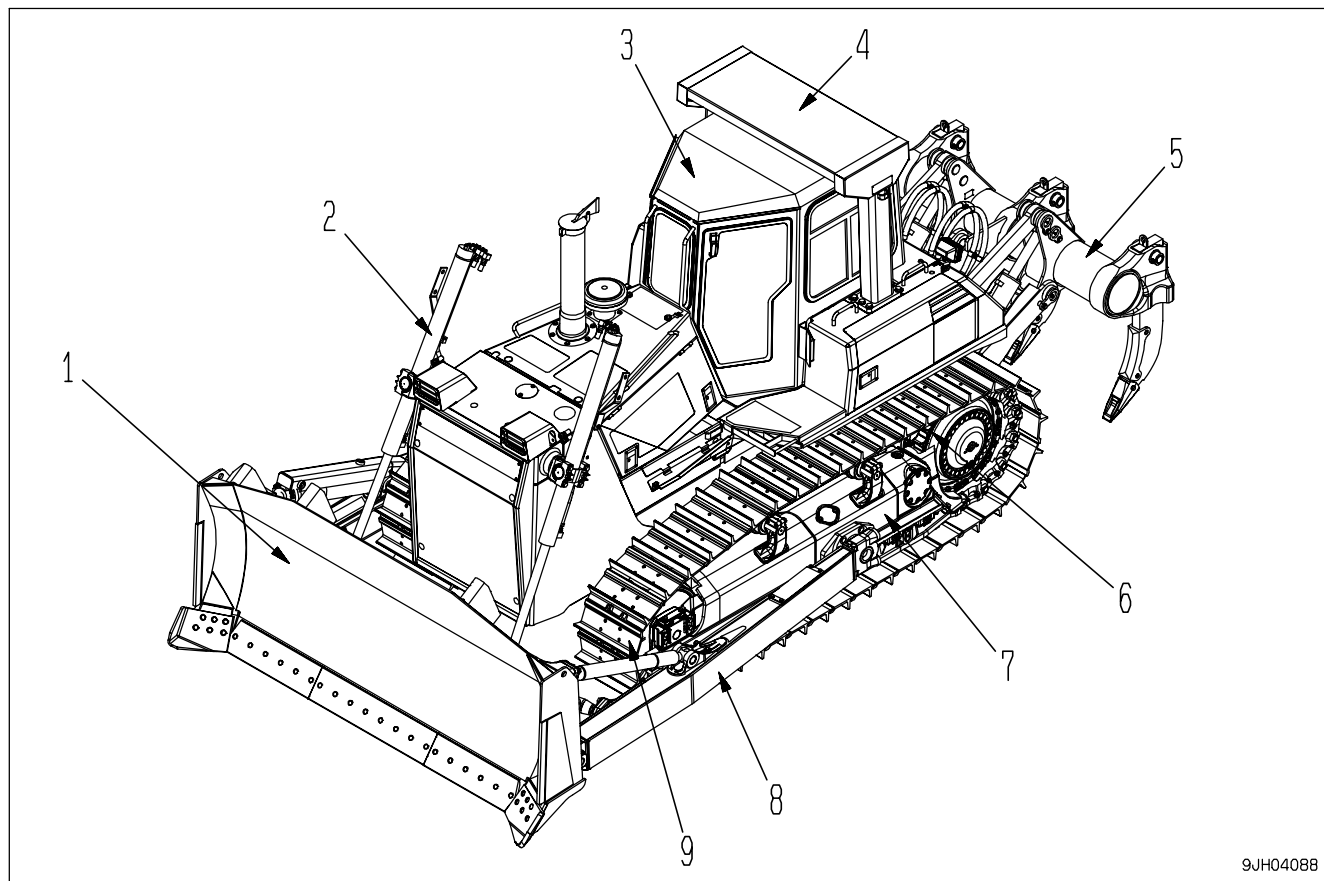

9JH04088

- (1) Blade
- (2) Blade lift cylinder
- (3) Cab
- (4) ROPS guard
- (5) Ripper

- (6) Sprocket
- (7) Track frame
- (8) Frame
- (9) Track shoe

GENERAL VIEW OF CONTROLS AND GAUGES

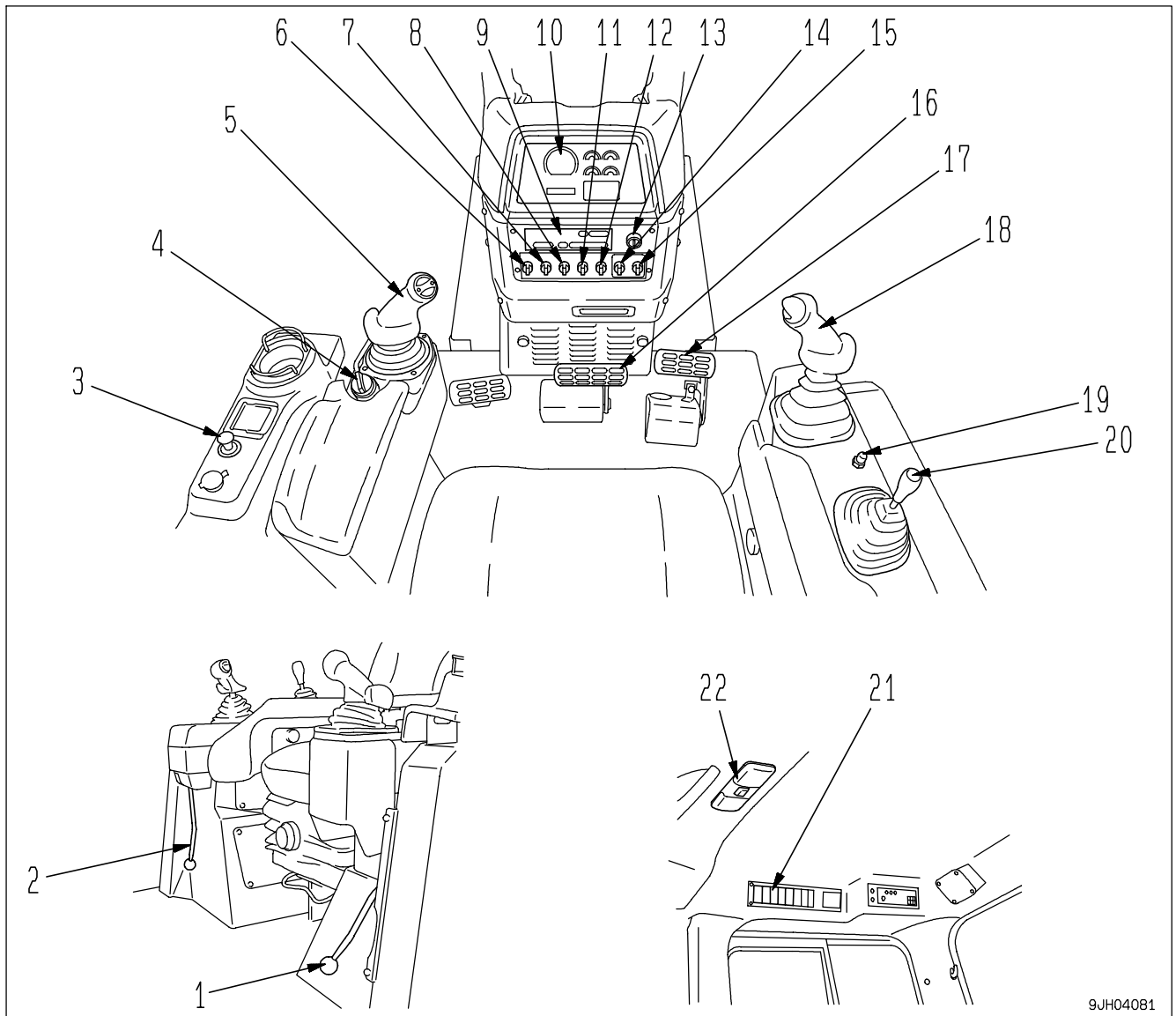

9JH04081

- | | |
|--------------------------------------------------------------|-----------------------------------|
| (1) Parking brake lever | (11) Rear lamp switch |
| (2) Work equipment lock lever | (12) Fan rotation selector switch |
| (3) Cigarette lighter | (13) Starting switch |
| (4) Fuel control dial | (14) Information switch |
| (5) Joystick
(Steering, directional and gear shift lever) | (15) Buzzer cancel switch |
| (6) Auto shift down switch | (16) Brake pedal |
| (7) Preset mode switch | (17) Deceleration pedal |
| (8) Front lamp switch | (18) Blade control lever |
| (9) Air conditioner panel or heater panel | (19) Horn switch |
| (10) Display panel A
(Speed range display, Engine speed) | (20) Ripper control lever |
| | (21) Wiper switch |
| | (22) Room lamp switch |

FRONT PANEL

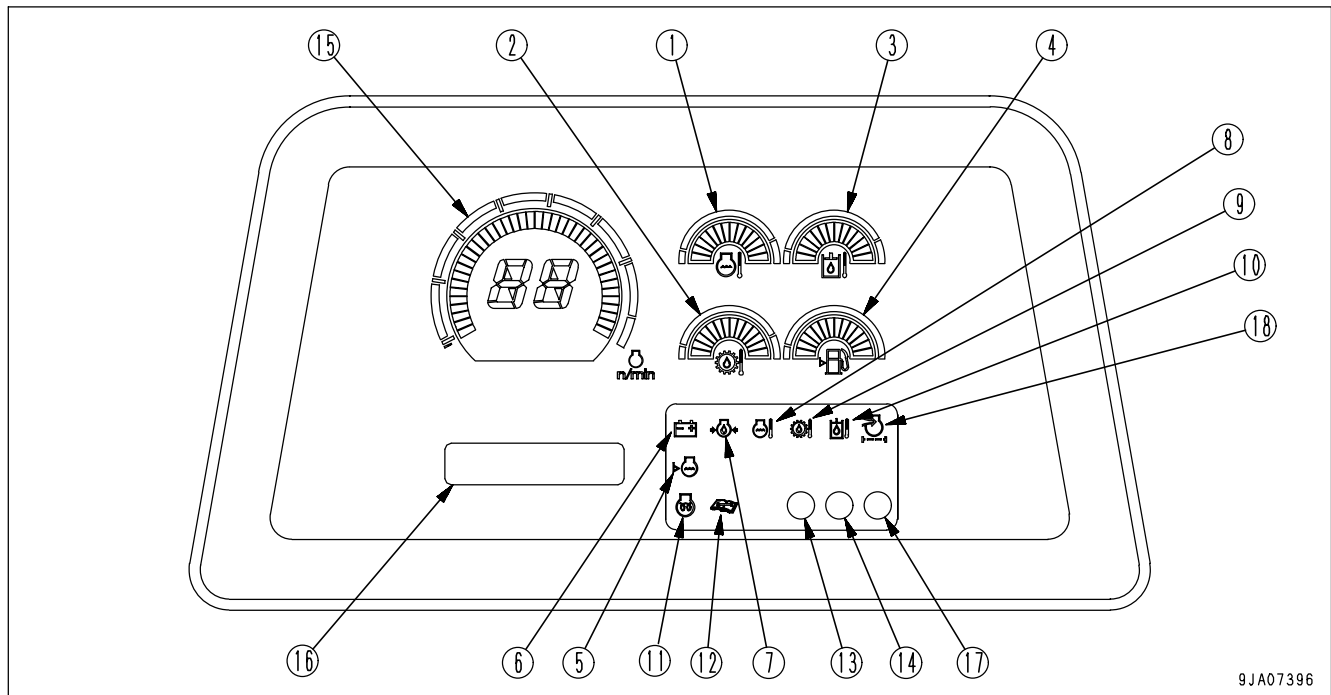

9JA07396

- | | |
|----------------------------------------------|-------------------------------------------------------------|
| (1) Engine coolant temperature gauge | (11) Engine pre-heating pilot lamp |
| (2) Power train oil temperature gauge | (12) Maintenance caution lamp |
| (3) Hydraulic oil temperature gauge | (13) Warning lamp |
| (4) Fuel level gauge | (14) Filter / oil change interval lamp |
| (5) Radiator coolant level monitor | (15) Display panel A
(Speed range display, Engine speed) |
| (6) Charge level caution lamp | (16) Display panel B (Multi-information) |
| (7) Engine oil pressure caution lamp | (17) Fan operation confirmation lamp |
| (8) Engine coolant temperature caution lamp | (18) Air cleaner clogging caution lamp (If equipped) |
| (9) Power train oil temperature caution lamp | |
| (10) Hydraulic oil temperature caution lamp | |

EXPLANATION OF COMPONENTS

The following is an explanation of devices needed for operating the machine.

To perform suitable operations correctly and safely, it is important to completely understand methods of operating the equipment, and the meanings of the displays.

FRONT PANEL

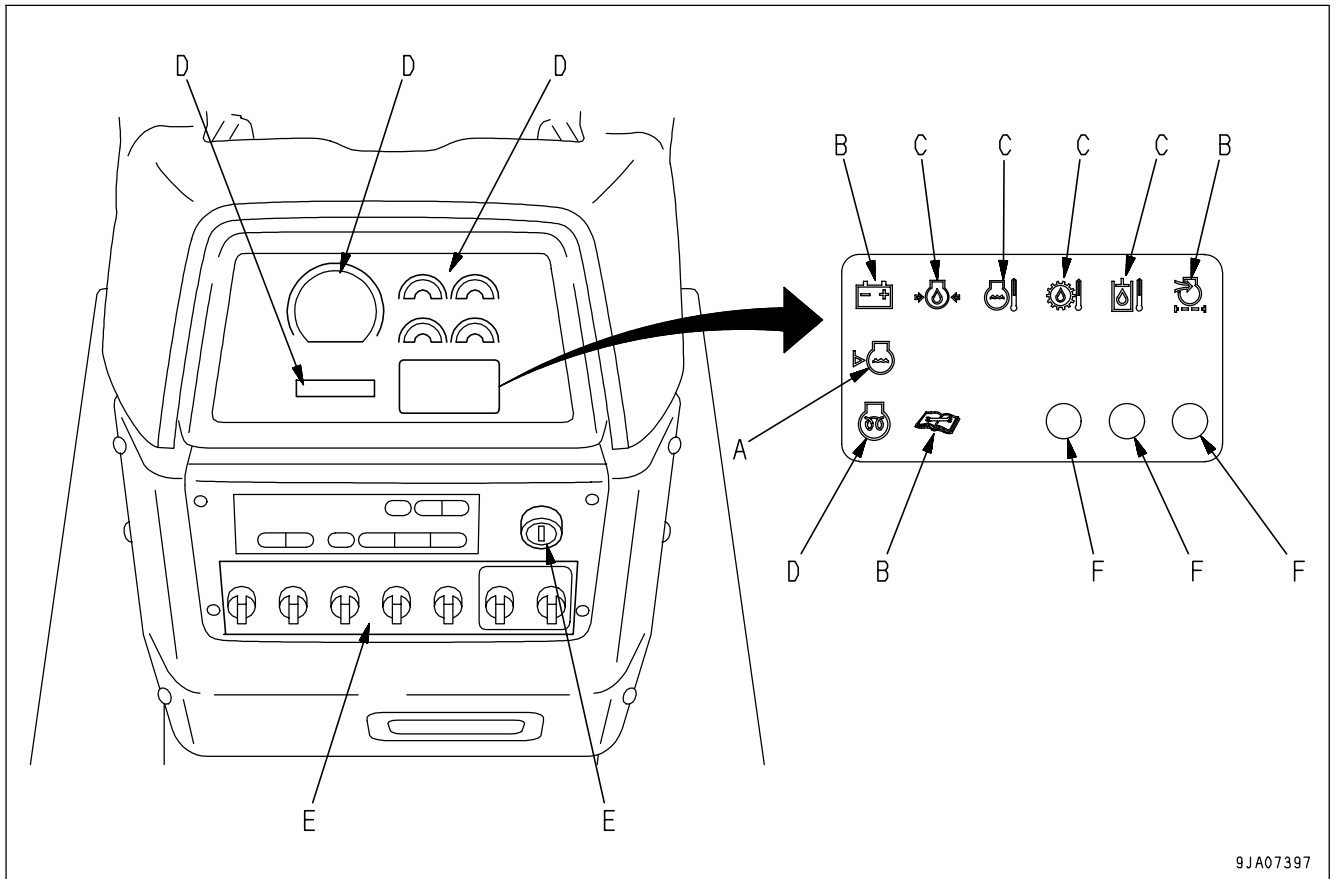

- | | |
|----------------------------|----------------|
| A: Check monitor group | D: Meter group |
| B: Caution monitor group | E: Switches |
| C: Emergency caution items | F: Lamps |

A: Check monitor group (for details, see "CHECK MONITOR GROUP (PAGE 3-7)")

Before the engine is started, the basic items among the check before starting items that must be checked are displayed.

If there is any abnormality, the caution lamp for the location of the abnormality flashes.

NOTICE

When carrying out checks before starting, do not simply rely on the monitor. Always refer to the periodic maintenance items or "OPERATION (PAGE 3-76)" to carry out the checks.

B: Caution monitor group (See "CAUTION MONITOR GROUP (PAGE 3-9)")

**CAUTION**

If the caution lamp for any of these items flashes, check and repair the appropriate item as soon as possible.

These are items which need to be observed when the engine is running. If any problem occurs, the item needing immediate repair is displayed. If there is any problem, the problem location on the caution lamp will flash.

C: Emergency caution items (for details, see "EMERGENCY CAUTION ITEMS (PAGE 3-11)")

**CAUTION**

If the caution lamp for any of these items flashes, stop the engine immediately or run it at low idling, and take the following action.

This displays the abnormal items that action must be taken on immediately the engine is running.

If there is any abnormality, the monitor showing the location of the abnormality will flash and the alarm buzzer will sound.

D: Meter group (for details, see "METER GROUP (PAGE 3-13)")

This consists of the preheating pilot lamp, power train oil temperature gauge, engine water temperature gauge, hydraulic oil temperature gauge, fuel gauge, dual/single selector display lamp, display panel A (speed range display, engine speed) and display panel B (multi-information).

E: Switches (for details, see "SWITCHES (PAGE 3-34)".)

These consist of the starting switch, buzzer cancel switch, front lamp switch, rear lamp switch, auto shift down switch, Preset mode switch, information switch, and Fan rotation selector switch.

F: Lamps (for details, see "LAMPS (PAGE 3-23)".)

These consist of the warning lamp and filter, oil change interval lamp and Fan operation confirmation lamp.

CHECK MONITOR GROUP

NOTICE

- When performing the check before starting, do not rely only on these monitors. Always refer to "OPERATION (PAGE 3-76)" to perform these checks.
- Park the machine on level ground and then check the monitor lamps.
- Confirm that monitor lamps light up about 2 seconds after the starting switch is turned to the ON position. If any monitor lamp does not light, contact your Komatsu distributor to inspect and repair.

REMARK

- When the starting switch is turned to the ON position, before starting the engine, the caution lamps flash for 2 seconds, the warning lamps light up for 2 seconds, and the alarm buzzer sounds for 2 seconds.
- The caution lamps cannot be checked for any malfunction until at least 5 seconds after the engine has been stopped.

This displays the basic items among the check before starting items that must be checked before starting the engine. If there is any abnormality, the caution lamp for that location will flash.

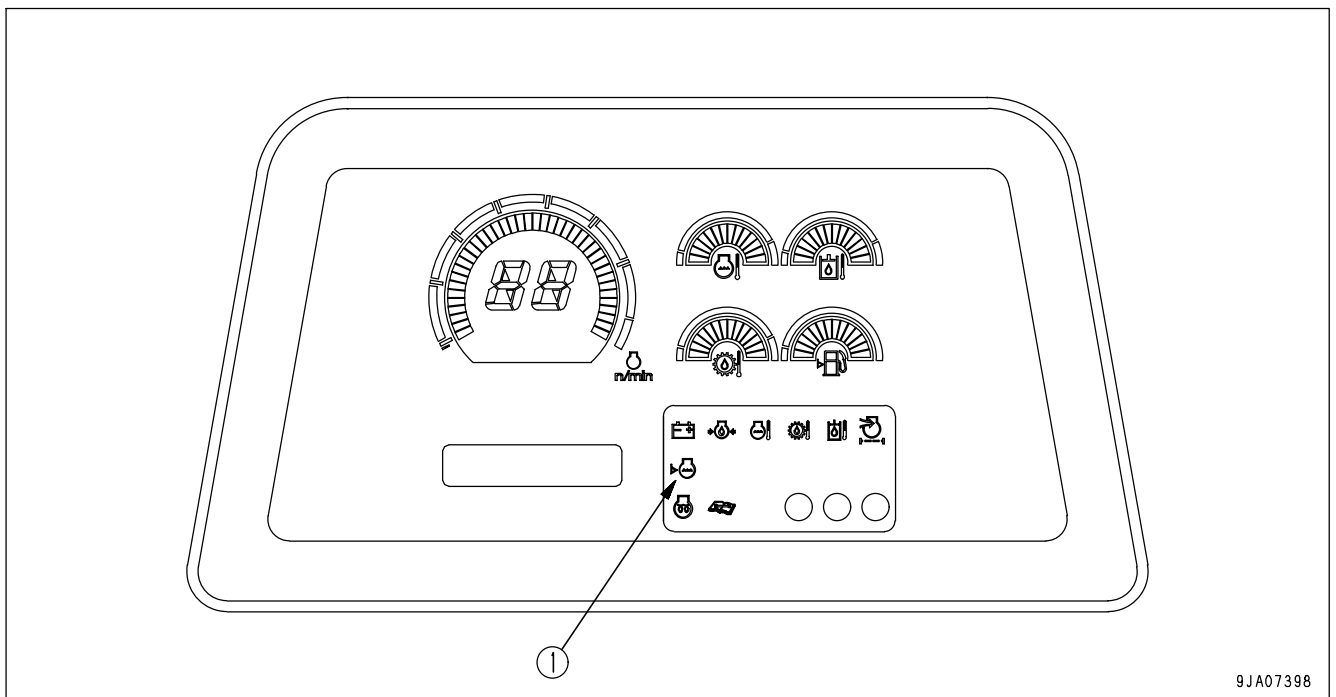

9JA07398

A(1) Radiator coolant level monitor

RADIATOR COOLANT LEVEL CAUTION LAMP

This lamp (1) warns the operator that the level of the cooling water in the radiator has gone down.

If the lamp flashes, check the level of the cooling water in the main radiator, and add water.

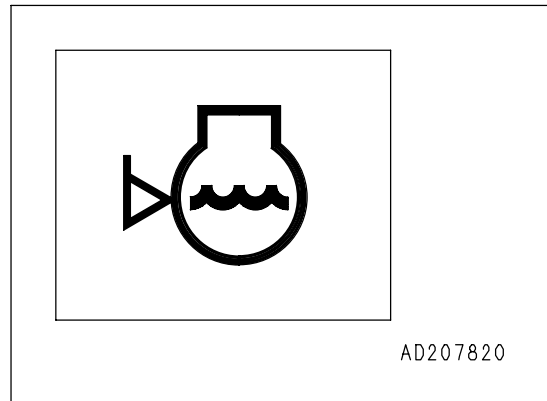

CAUTION MONITOR GROUP



If these caution lamps flash, check and repair the appropriate location as soon as possible.

NOTICE

- Park the machine on level ground and check the monitor lamps.
- Confirm that monitor lamps light up about 2 seconds after the starting switch is turned to the ON position. If any monitor lamp does not light, contact your Komatsu distributor to inspect and repair.

These are items which need to be observed when the engine is running. If any problem occurs, the item needing immediate repair is displayed. If there is any problem, the problem location on the caution lamp will flash.

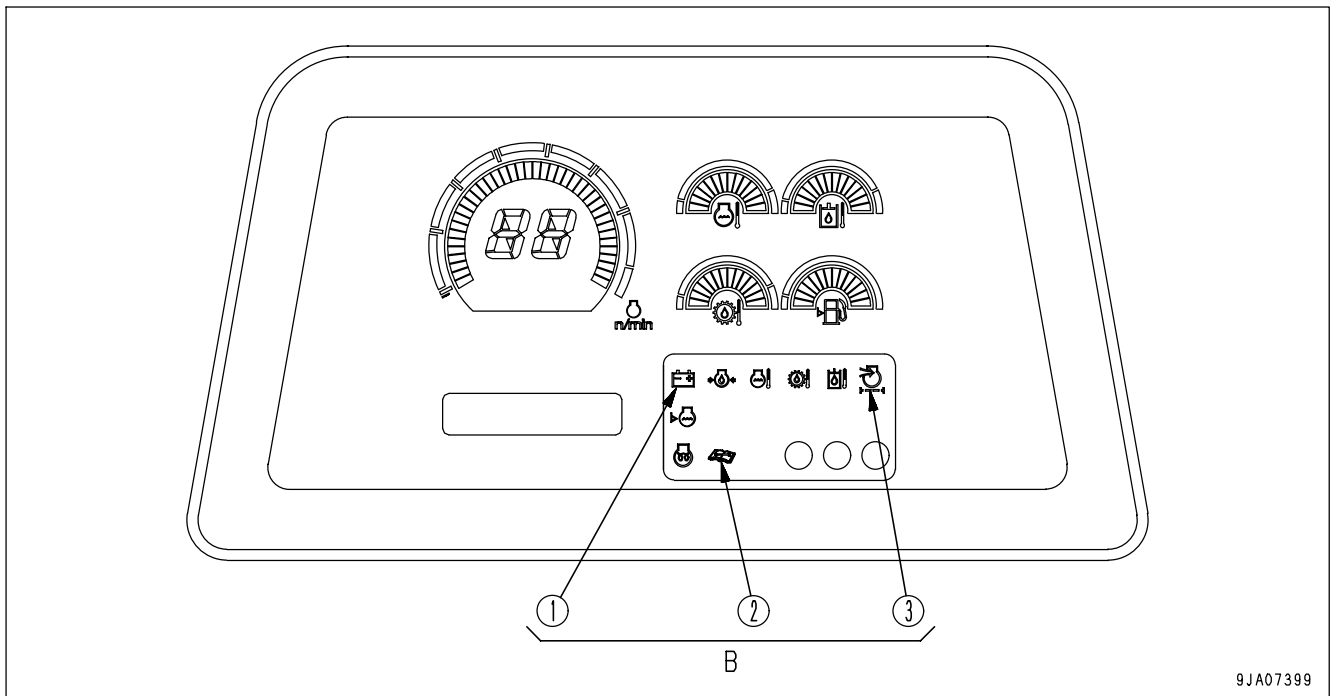

9JA07399

B(1) Charge level caution lamp
 B(2) Maintenance caution lamp

B(3) Air cleaner clogging caution lamp (If equipped)

CHARGE LEVEL CAUTION LAMP

Lamp (1) indicates an abnormality in the charging system while the engine is running.

If the monitor lamp flashes, check the V-belt tension. If any abnormality is found, see "OTHER TROUBLE (PAGE 3-148)".

REMARK

This lamp may light up momentarily when the engine is started or when the engine is stopped. It does not indicate a problem.

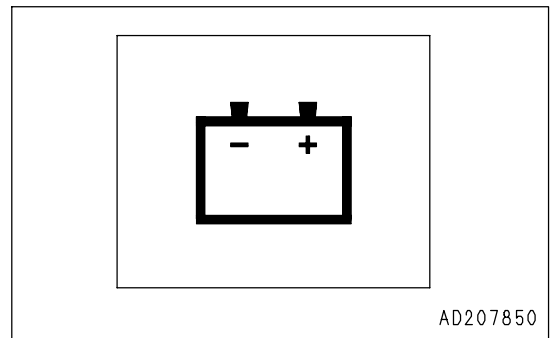

AD207850

MAINTENANCE CAUTION LAMP

This lamp (2) lights up for approx. 30 seconds after the starting switch is turned to the ON position if the filter or oil replacement interval has been reached.

After replacing the indicated filter or oil displayed on display panel B (multi-information), reset the interval. For details, see "METHOD OF USING MAINTENANCE MODE (PAGE 3-27)".

The lamp goes out.

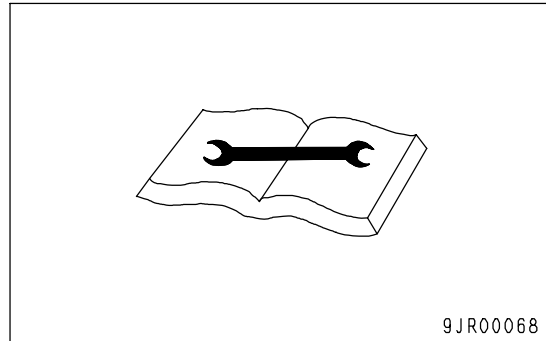

9JR00068

REMARK

At the same time, the filter or oil replacement interval lamp also lights up or flashes.

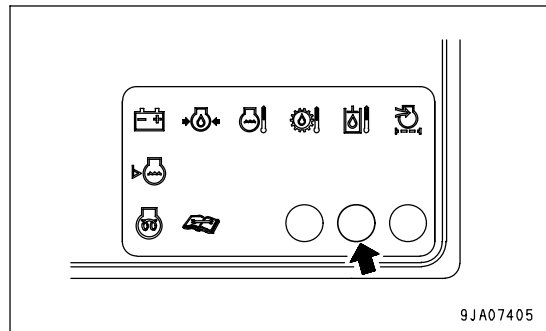

9JA07405

AIR CLEANER CLOGGING CAUTION LAMP

(If equipped)

Lamp (3) warns operator that the air cleaner is clogged.

If it flashes, stop the engine, check and clean the air cleaner.

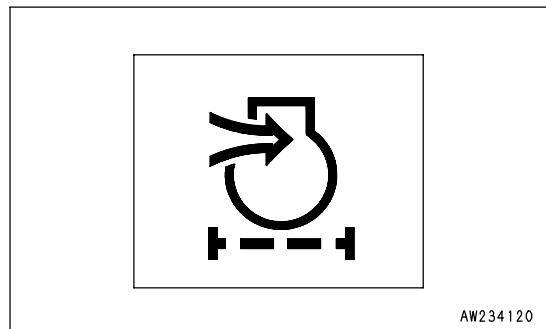

AW234120

EMERGENCY CAUTION ITEMS

! CAUTION

If any of the caution lamps begins to flash, stop the engine or reduce the engine speed to low idle immediately and check the trouble spot for necessary actions.

These items must be monitored when the engine is running. If there is any problem, the caution lamp for the location of the problem and warning lamp (A) flash, and the alarm buzzer sounds intermittently. Take the necessary action immediately.

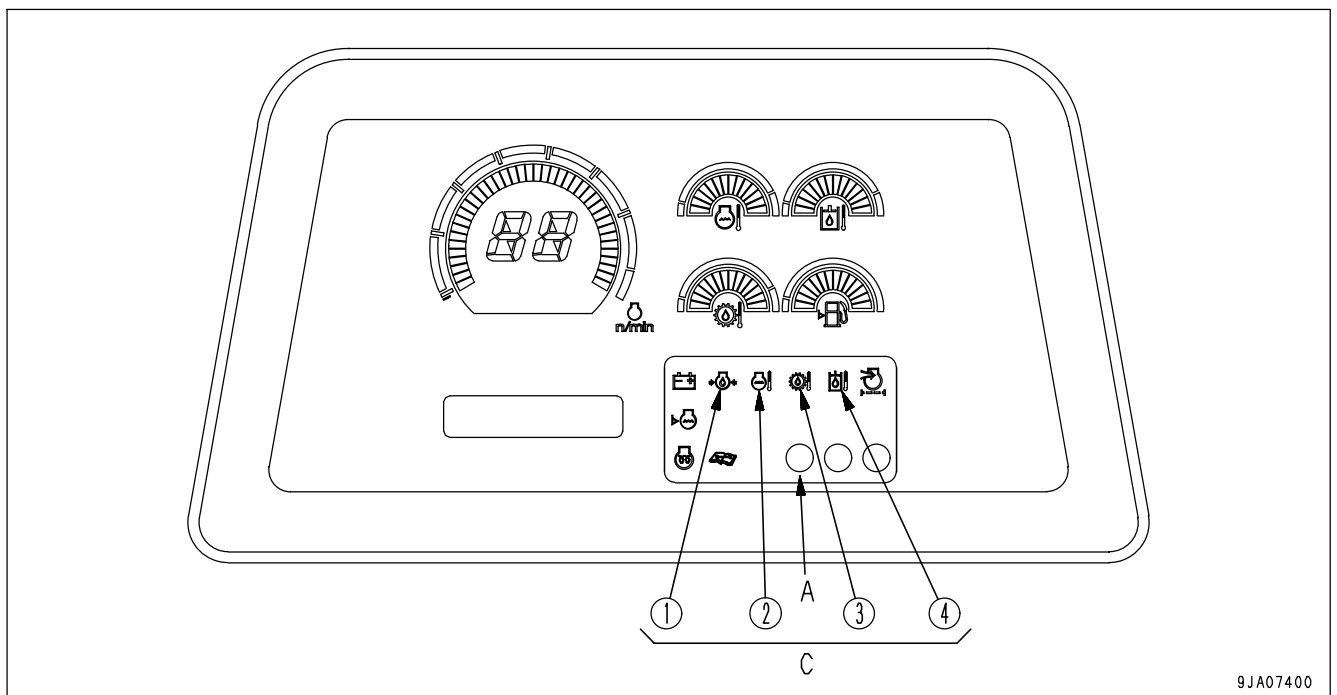

9JA07400

C (1) Engine oil pressure caution lamp

C (2) Engine coolant temperature caution lamp

C (3) Power train oil temperature caution lamp

C (4) Hydraulic oil temperature caution lamp

ENGINE OIL PRESSURE CAUTION LAMP

This lamp (1) indicates low engine oil pressure.

If the monitor lamp flashes, stop the engine and check it immediately.

REMARK

The alarm buzzer sounds, when the starting switch is turned to ON immediately after the engine oil has been changed. It does not indicate a problem.

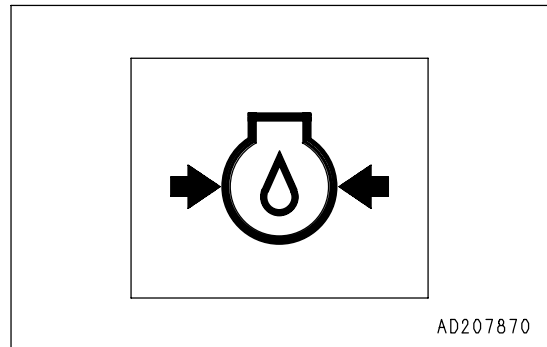
**ENGINE COOLANT TEMPERATURE CAUTION LAMP**

This lamp (2) indicates a rise in the coolant temperature.

When the monitor lamp flashes, run the engine at low idle speed until green range of the engine coolant temperature gauge lights.

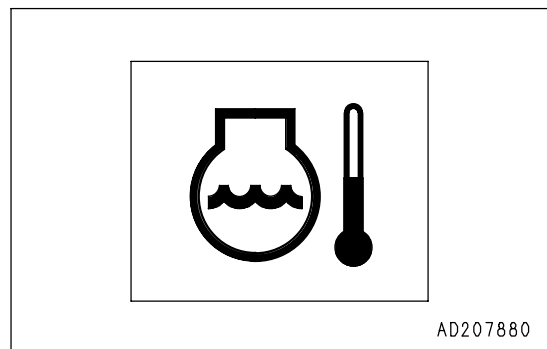
**POWER TRAIN OIL TEMPERATURE CAUTION LAMP**

Lamp (3) warns operator that the torque converter outlet port oil temperature has risen.

If it flashes, run the engine at low idling until the power train oil temperature gauge goes down to the green range.

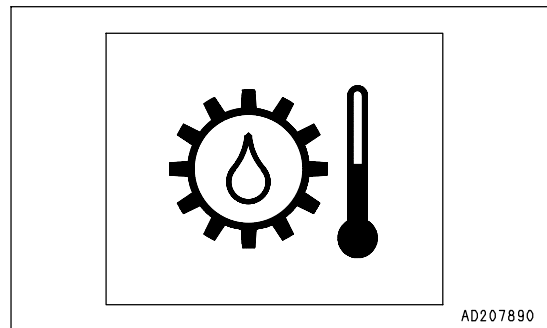
**HYDRAULIC OIL TEMPERATURE CAUTION LAMP**

Lamp (4) indicates a rise in the hydraulic oil temperature.

When the monitor lamp flashes, stop the machine and run the engine at the low idling speed until oil temperature falls.

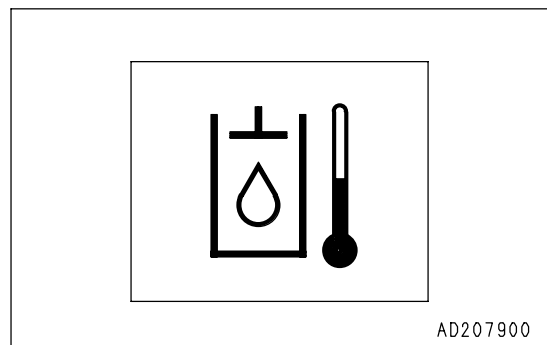

METER GROUP

NOTICE

When the engine is stopped, turn that the starting switch to the ON position and check that the gauge or monitor for the engine water temperature gauge, power train oil temperature gauge, and fuel gauge light up.

If they do not light up, please contact your Komatsu distributor for repairs.

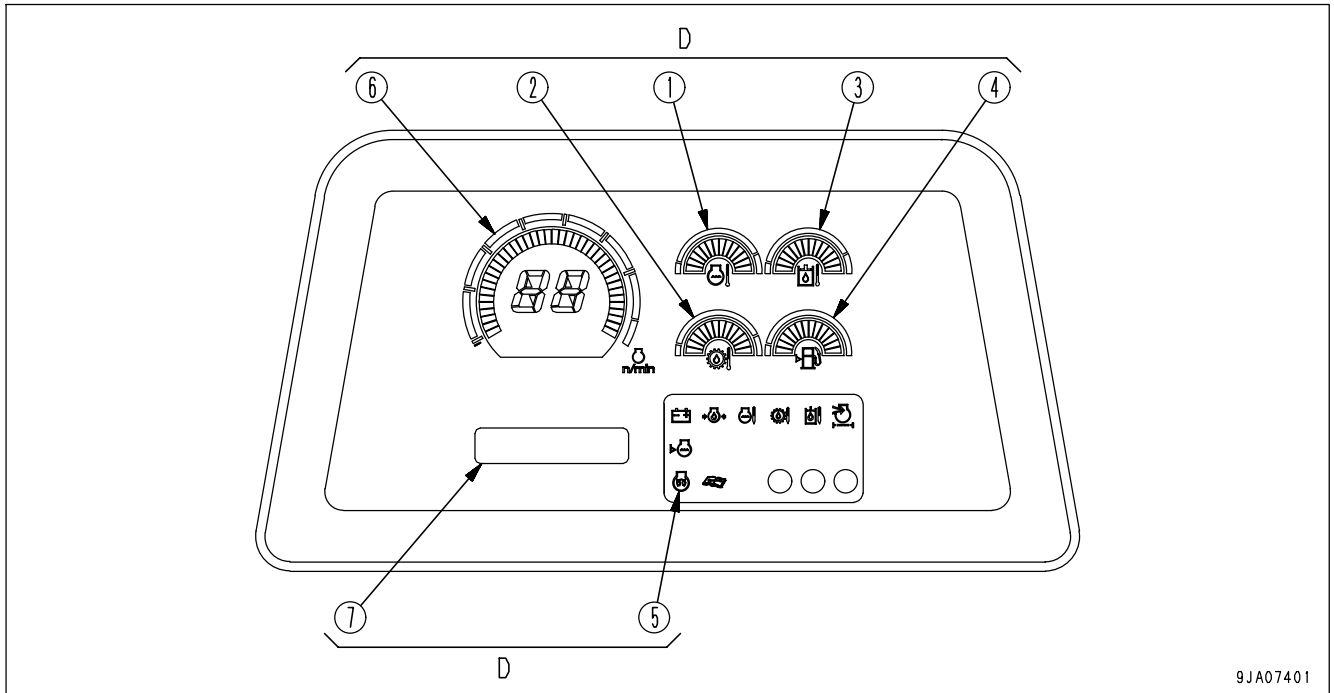

D(1) Engine coolant temperature gauge

D(2) Power train oil temperature gauge

D(3) Hydraulic oil temperature gauge

D(4) Fuel level gauge

D(5) Engine pre-heating pilot lamp

D(6) Display panel A

(Speed range display, engine speed)

D(7) Display panel B (Multi-information)

ENGINE COOLANT TEMPERATURE GAUGE

NOTICE

If the coolant temperature gauge often enters red range (C), check the radiator for clogging.

Gauge (1) indicates temperature of the engine coolant.

If the temperature is normal during operation, green range (B) will light.

If red range (C) lights during operation, move the fuel control dial to lower engine speed to approx. 3/4 of the full speed, and run until the coolant temperature enters green range (B).

During operation, if red range (C) lights, engine coolant temperature monitor flashes and the alarm buzzer sounds, stop the machine and run at low idle until coolant temperature enters green range (B).

(A): White range

(B): Green range

(C): Red range

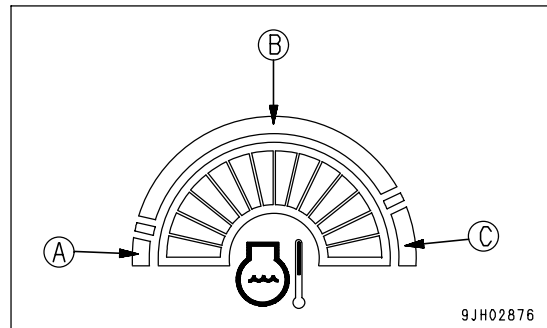

POWER TRAIN OIL TEMPERATURE GAUGE

NOTICE

If the power train oil temperature gauge often enters red range (C), shift down one speed range to reduce the load on the power train when operating.

Gauge (2) indicates the torque converter outlet oil temperature.

If the temperature is normal during operation, green range (B) will light.

If red range (C) lights up during operation, move the fuel control dial to lower engine speed to approx. 3/4 of the full speed, reduce the load and run until the oil temperature enters green range (B).

If red range (C) lights up, the power train oil temperature caution lamp flashes and the alarm buzzer sounds during operations, stop the machine, and run the engine at low idling until the oil temperature goes down to green range (B).

(A): White range

(B): Green range

(C): Red range

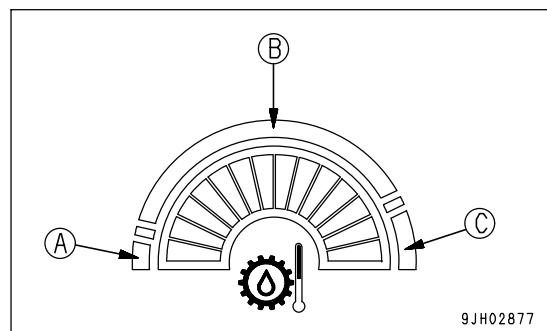

HYDRAULIC OIL TEMPERATURE GAUGE

Gauge (3) indicates the hydraulic oil temperature.

If the temperature is normal during operation, green range (B) will light.

If red range (C) lights up during operation, move the fuel control dial to lower engine speed to approx. 3/4 of the full speed, reduce the load and run until the oil temperature enters green range (B).

(A): White range

(B): Green range

(C): Red range

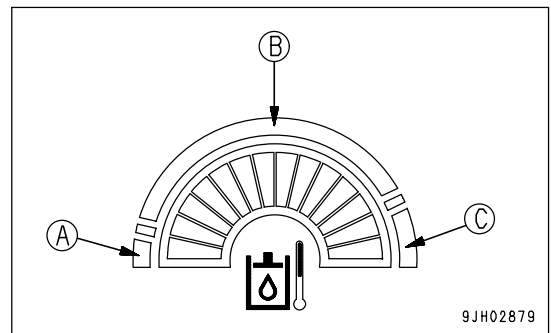
**FUEL LEVEL GAUGE**

Gauge (4) fuel level in the fuel tank.

During normal operation, the green range (B) should be lit.

If red range (A) lights up during operation, add fuel immediately. If this is not done, the engine speed will become irregular or an error display will be shown on the monitor.

(A): Red range

(B): Green range

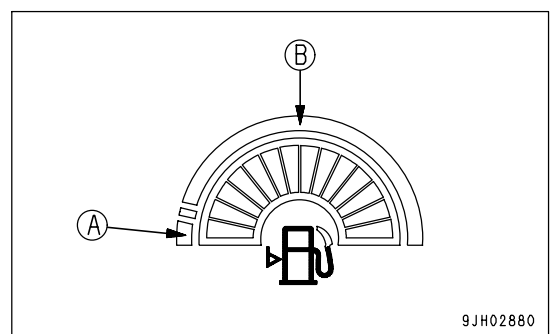
**REMARK**

- The display is not proportional to the amount of fuel remaining.
- If only the red range (A) lights up, there is less than 60 liters (15.85 US gal) of fuel remaining.

ENGINE PRE-HEATING PILOT LAMP

Lamp (5) indicates that engine is being pre-heated by the electrical heater during cold weather.

The engine controller detects the coolant temperature and automatically actuates pre-heating in low temperatures when starting the engine.

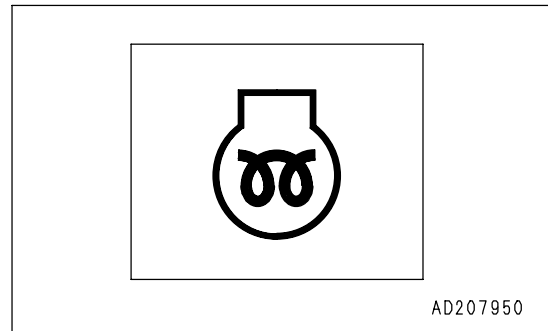
**DISPLAY PANEL A (speed range display, engine speed)**

Meter (6) displays the transmission speed range being used on the machine and engine speed.

- The travel direction (A) and speed range (B) are displayed in the center of the speed range display.

(A) F: FORWARD

R: REVERSE

N: Neutral

P: Parking brake lever at LOCK position

(B) 1: 1st

2: 2nd

3: 3rd

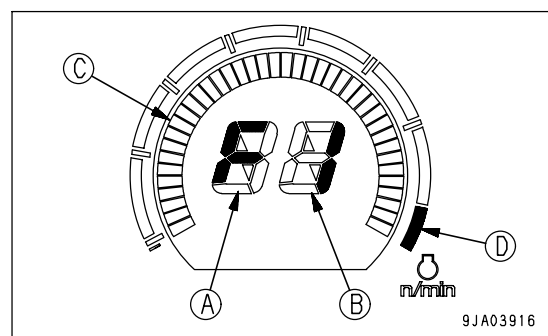

Example: F1 is displayed for FORWARD 1st

- Bar graph (C) around the outside of the display shows the engine speed. If the bar graph reaches red range (D) during operation, take action to reduce the engine speed. Always keep the bar graph in the green range.

DISPLAY PANEL B (Multi-information)

The top and bottom lines in display panel B (multi-information) display information related to the condition of the machine.

The content of the display is divided into "OPERATING MODE" and "MAINTENANCE MODE". Use the buzzer cancel switch to switch between the operating mode and maintenance mode.

For details of switching the mode, see "BUZZER CANCEL SWITCH (PAGE 3-20)".

OPERATING MODE (default screen)

Use this mode when operating the machine.

REMARK

When the starting switch is turned from the OFF position to the ON position, display panel B (multi-information) always displays the operating mode.

The following information is displayed by the operating mode.

Top line (A): Action code

If any problem occurs on the machine, an action code is displayed. If an action code appears, take the applicable action. For details, see "OTHER TROUBLE (PAGE 3-148).

This displays various types of filter or oil replacement intervals have been reached.

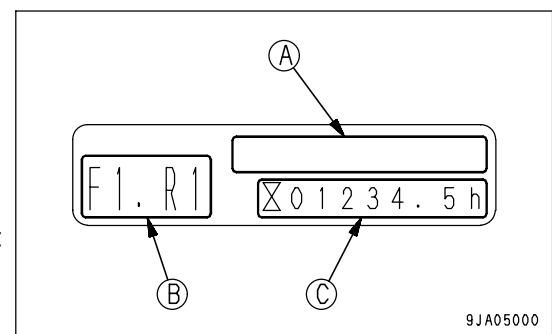

Bottom line, left (B): Preset mode

When the preset mode switch is ON, the selected preset mode is displayed.

For details of selecting the preset mode, see "GEARSHIFTING OPERATION USING PRESET MODE FUNCTION (PAGE 3-108)".

Bottom line, right (C): Service meter or engine speed

Use the information switch to switch the display between the service meter and engine speed. For details of switching the display, see "INFORMATION SWITCH (PAGE 3-22)".

Service meter

This displays the total number of hours that the machine has been operated. Use the display to determine the intervals for periodic maintenance.

While the engine is running, the service meter advances, even if the machine is not being operated.

While the engine is running, the hourglass mark at the side of the meter flashes to show that the meter is advancing.

The meter advances 0.1h for every 6 minutes that the engine is running, regardless of the engine speed.

Maintenance mode

This displays various types of information related to maintenance of the machine.

The maintenance mode is displayed by continuing to turn the buzzer cancel switch in the \diamond direction for 2.5 seconds.

For details, see "METHOD OF USING DISPLAY PANEL B (Multi-information) (PAGE 3-25)".

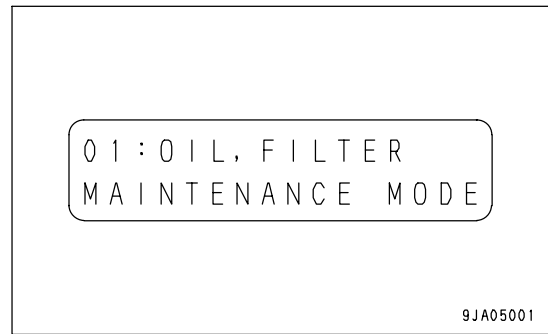

SWITCHES

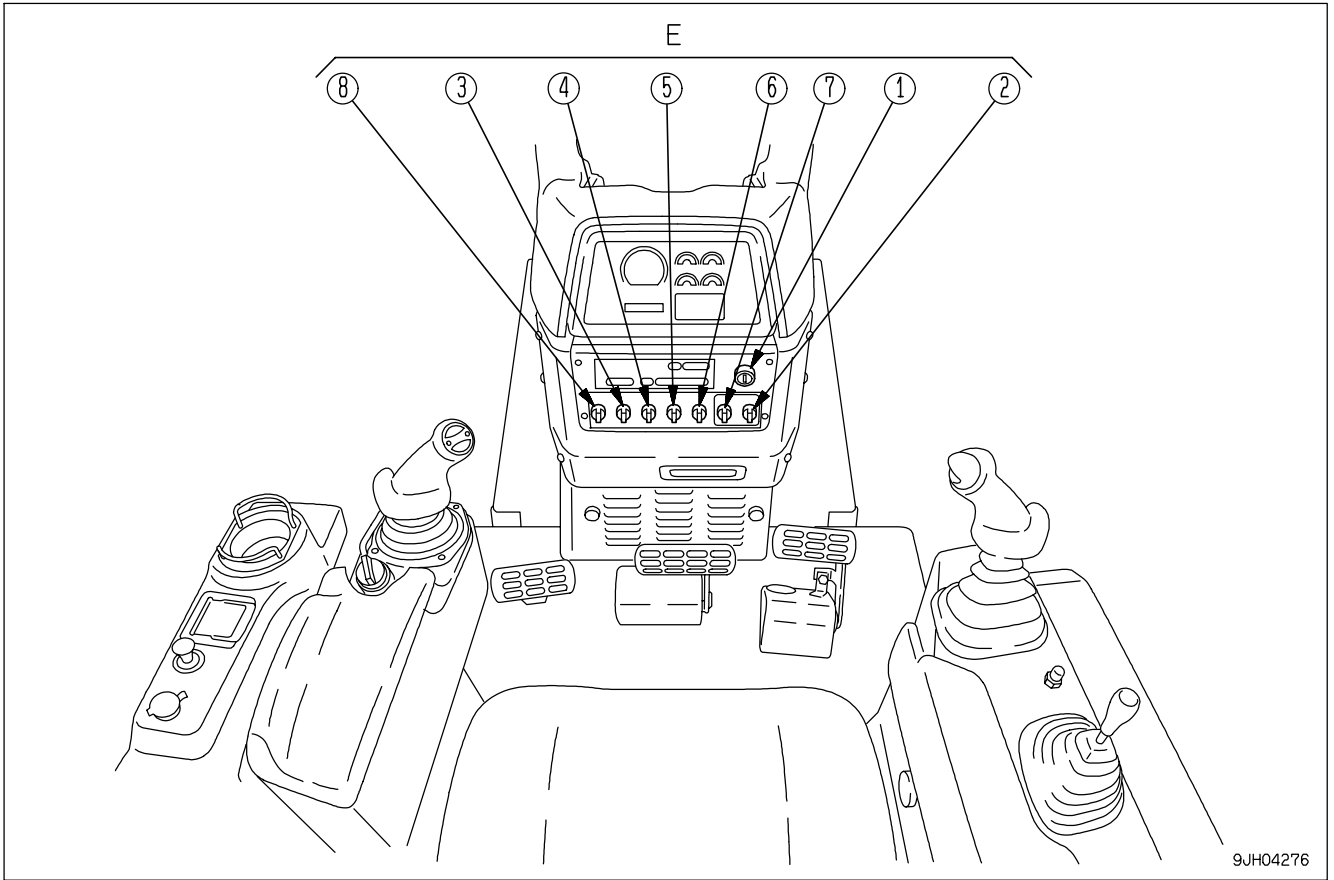

E(1) Starting switch

E(2) Buzzer cancel switch

E(3) Preset mode switch

E(4) Front lamp switch

E(5) Rear lamp switch

E(6) Fan rotation selector switch

E(7) Information switch

E(8) Auto shift down switch

STARTING SWITCH

Switch (1) is used to start the engine.

OFF

Key insertion-withdrawal position. None of electrical circuits activate.

ON

Charging and electric device circuits activate. Keep key in the ON position after starting.

START

In this key position, the starting motor will crank the engine. Immediately after starting the engine, release the key which will automatically return to the ON position.

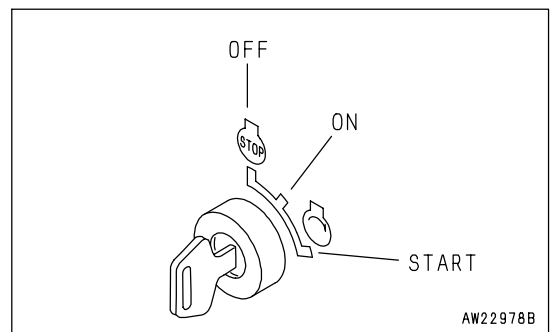

BUZZER CANCEL SWITCH

This switch (2) is used to operate control panel B (multi-information) or to stop the alarm buzzer.

When the switch is released, it returns automatically to the center position.

- **When display panel B (multi-information) is in operation mode**
 - When the alarm buzzer is sounding, turn this switch to the left or right to stop the buzzer.
 - If the switch is held at the ◊ position for at least 2.5 seconds, the display switches to the maintenance mode.

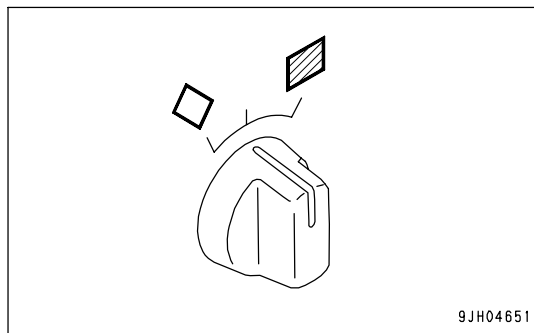

9JH04651

- **When display panel B (multi-information) is in the maintenance mode**

■ position: Cancel or reset to operation mode

◊ position: Confirms selection or selected item

For details, see "METHOD OF USING DISPLAY PANEL B (Multi-information) (PAGE 3-25)".

PRESET MODE SWITCH

Turn the switch (3) to the right to set the desired transmission speed range before starting (F1-R1, F1-R2, F2-R2).

○ (OFF) position: Manual mode

┆ (ON) position: Preset mode

For details, see "GEARSHIFTING OPERATION USING PRESET MODE FUNCTION (PAGE 3-108)".

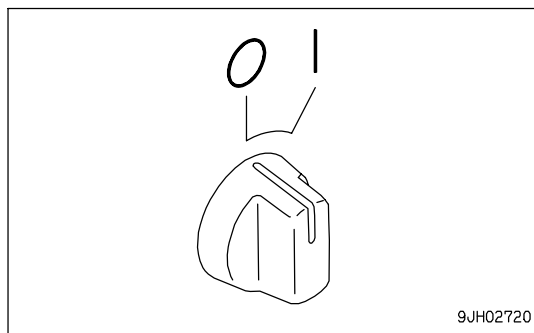

9JH02720

FRONT LAMP SWITCH

This switch (4) lights up when the front lamp and panel lamp light up.

○ (OFF) position: Lights out

┆ (ON) position: Lights on

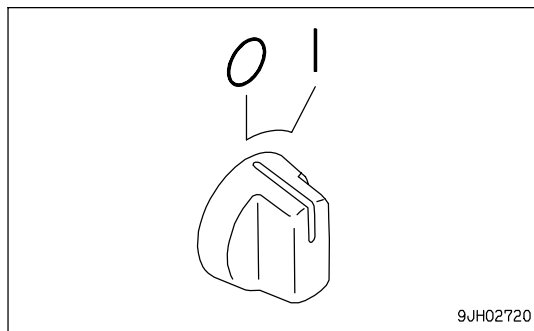

9JH02720

REAR LAMP SWITCH

This switch (5) lights up when the rear lamp and panel lamp light up.

- (OFF) position: Lights out
- ┆ (ON) position: Lights on

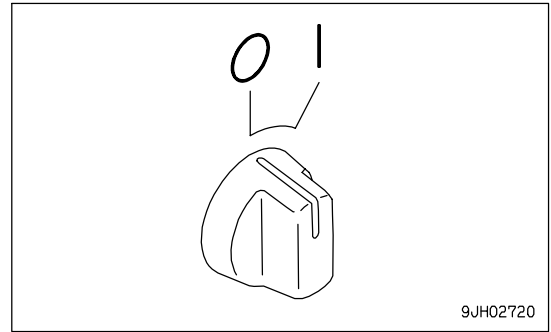
**FAN ROTATION SELECTOR SWITCH**

This switch (6) is used to switch the direction of rotation of the cooling fan.

- position : Normal rotation
Normally use this position.
The air is pushed out to the front through the radiator mask.
The speed of the fan changes to match the temperature of the coolant in order to improve the cooling efficiency.

REV position: Reverse rotation

The fan rotates in the reverse direction.
The air is sucked into the engine room through the radiator mask. This makes it possible to use the heat from the radiator to warm the operator's cab.
Operating with the fan rotating in reverse may cause overheating, so use this function only during cold weather (ambient temperature below 15°C).

CLN position: Cleaning

The fan rotates in the reverse direction at high speed, regardless of the coolant temperature.
Use this function to clean the radiator fins.

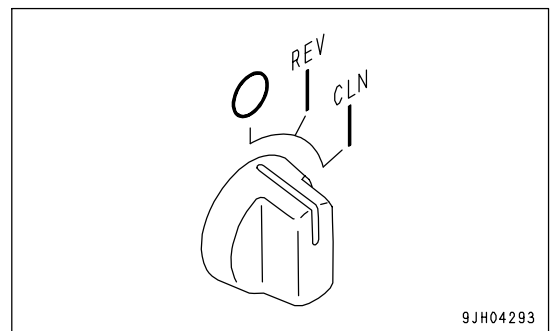

Stop the engine and turn the starting switch to the ON position before operating this switch.

REMARK

- If the engine is running, the direction of rotation of the fan will not change even when the fan rotation selector switch is operated. The fan operation confirmation lamp will flash to inform the operator that the direction of rotation of the fan has not changed. Stop the engine, then start it again. The direction of rotation of the fan will be switched.
- When the cooling fan is being operated in reverse or in the cleaning mode, even if the starting switch is turned to the OFF position, the hydraulic circuit protection function will be actuated and the power supply will not be cut immediately. During this time, the fan operation confirmation lamp will flash to inform the operator that the power supply is being maintained.

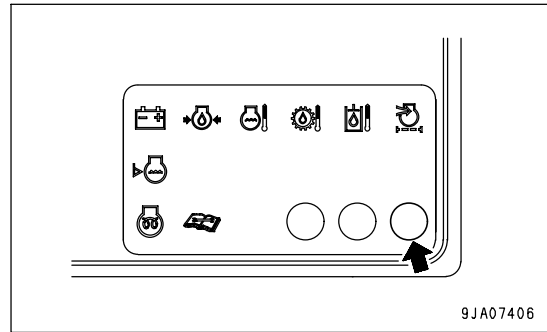

INFORMATION SWITCH

This switch (7) is used to operate display panel B (multi-information). When the switch is released, it returns automatically to the center position.

- **When display panel B (multi-information) is in the operation mode**
turn the switch to < or > to switch the display to service meter or engine speed.
- **When display panel B (multi-information) is in the maintenance mode**
It is used to move between sub modes, between items, to move the cursor, or to change values.
For details, see "METHOD OF USING DISPLAY PANEL B (Multi-information) (PAGE 3-25)".

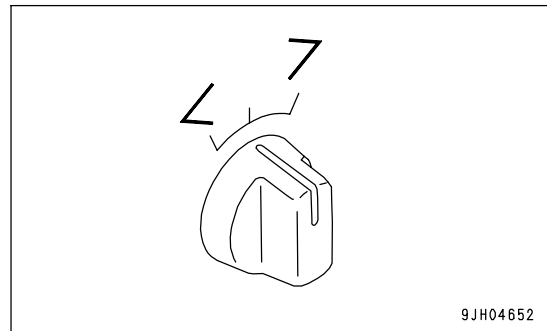

AUTO SHIFT DOWN SWITCH

When this switch (8) is operated to the right, if the travel speed drops because of the load conditions when traveling, the transmission automatically shifts to low speed.

- (OFF) position: Automatic operation canceled
- ┆ (ON) position: Automatically shifts down to low speed

For details, see "AUTO SHIFT DOWN FUNCTION (PAGE 3-110)".

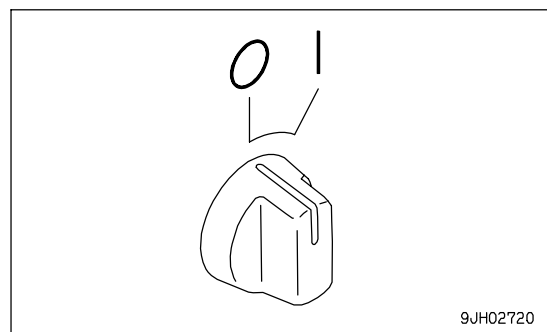

LAMPS

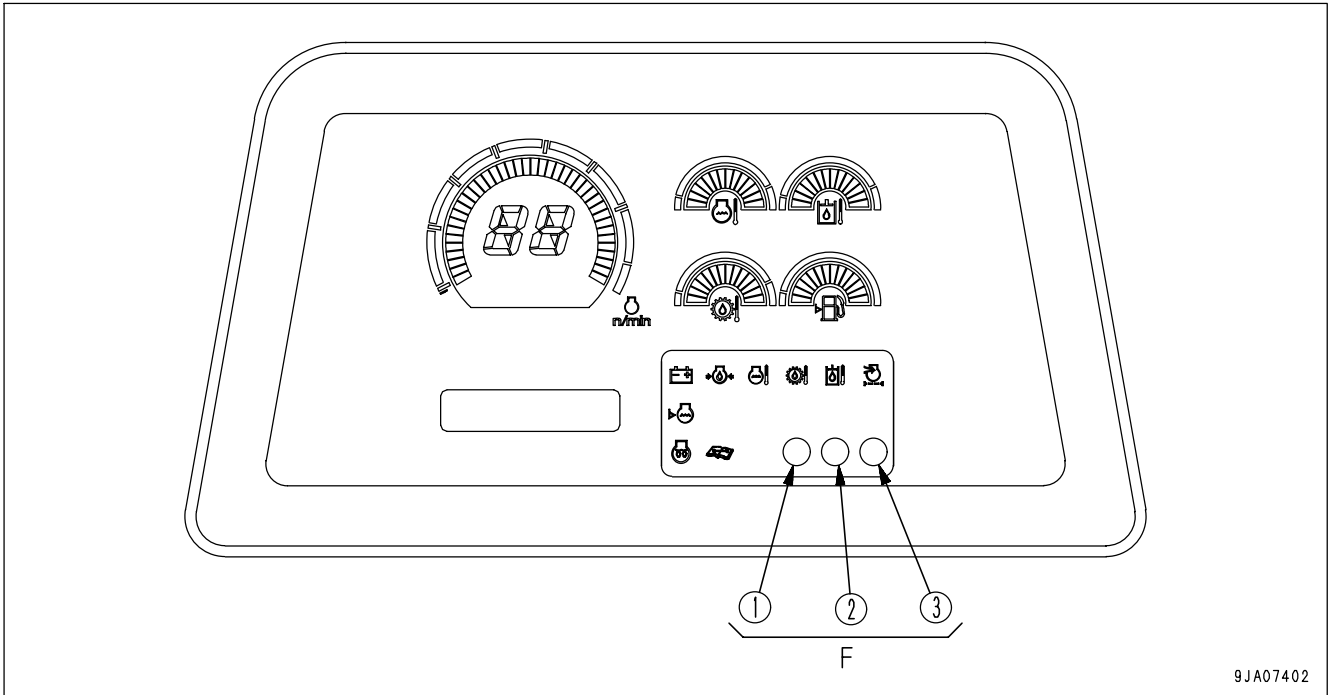

F(1) Warning lamp

F(2) Filter/oil change interval lamp

F(3) Fan operation confirmation lamp

WARNING LAMP

(Red)

NOTICE

If alarm buzzer sounds, stop work immediately and perform inspection and maintenance of the appropriate point.

This lamp (1) flashes when the caution lamp flashes and when an action code is displayed on display panel B (multi-information).

When the caution lamp (C) of an emergency warning item flashes, or when the part of an action code is displayed, the alarm buzzer sounds continuously at the same time.

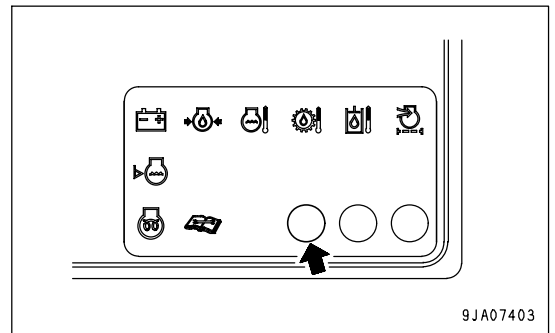

9JA07403

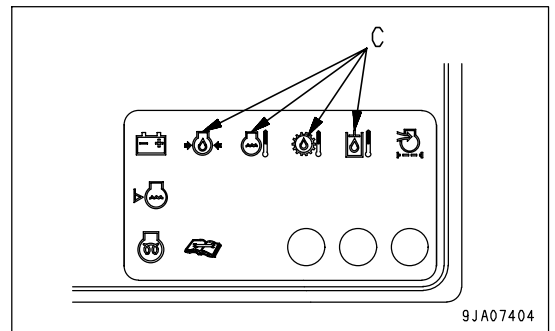

9JA07404

FILTER/OIL CHANGE INTERVAL LAMP

(Yellow)

This lamp (2) lights up when the time for replacing the filter or oil is near.

REMARK

This lamp (2) lights up if there is less than 30 hours remaining until replacement, and flashes when the replacement interval has passed.

At the same time, maintenance caution lamp (A) also lights up.

After replacing the indicated filter or oil displayed on display panel B (multi-information), reset the interval. For details, see "METHOD OF USING MAINTENANCE MODE (PAGE 3-27)".

The lamp goes out.

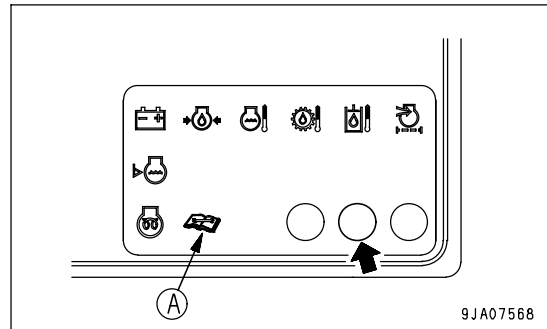
**FAN OPERATION CONFIRMATION LAMP**

(Orange)

If the fan rotation selector switch is operated when the engine is running, this lamp flashes to warn the operator that the fan operation cannot be switched.

- Before the engine starts, if the starting switch is turned to the ON position and the fan rotation selector switch is set to the reverse mode (REV) position or clean mode (CLN) position, lamp (3) lights up to inform the operator that the fan is set to reverse mode (REV) or clean mode (CLN). After the engine starts, the lamp goes out.

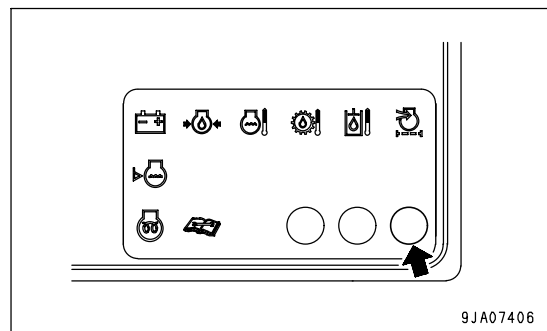

METHOD OF USING DISPLAY PANEL B (Multi-information)

To switch from the operation mode to the maintenance mode, turn the buzzer cancel switch to the ◊ position and hold it there for at least 2.5 seconds. The screen will switch to the maintenance mode.

On the first screen, the oil and filter maintenance mode is displayed.

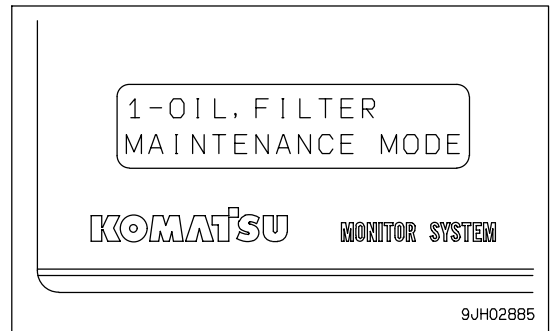
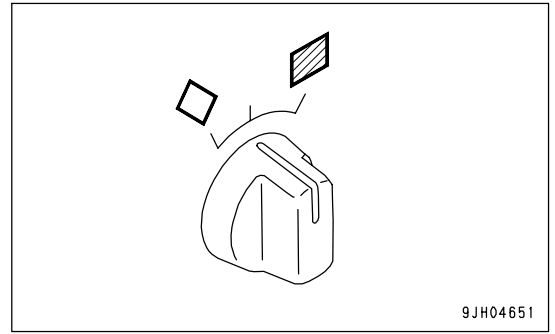

EXPLANATION OF MODES AND CONTROLS

The maintenance mode has the following 4 sub modes.

Sub mode	Function	Reference items
Oil/filter maintenance mode	Oil or filter replacement time is displayed	METHOD OF USING MAINTENANCE MODE(3-27 PAGE)
PM clinic auxiliary mode	Engine speed or hydraulic circuit pressure is displayed	METHOD OF USING PM CLINIC AUXILIARY MODE(3-29 PAGE)
Fault code display mode	Fault codes for electronic control related parts are displayed	METHOD OF USING FAULT CODE DISPLAY MODE(3-30 PAGE)
Adjustment mode	Adjusts monitor brightness, etc.	METHOD OF USING USER ADJUST MODE(3-31 PAGE)

Use information switch (1) and buzzer cancel switch (2) to operate each mode.

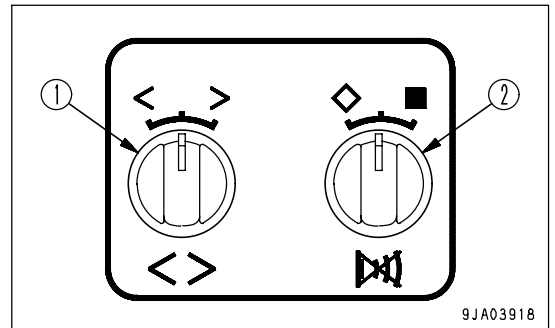

METHOD OF SELECTING MODES

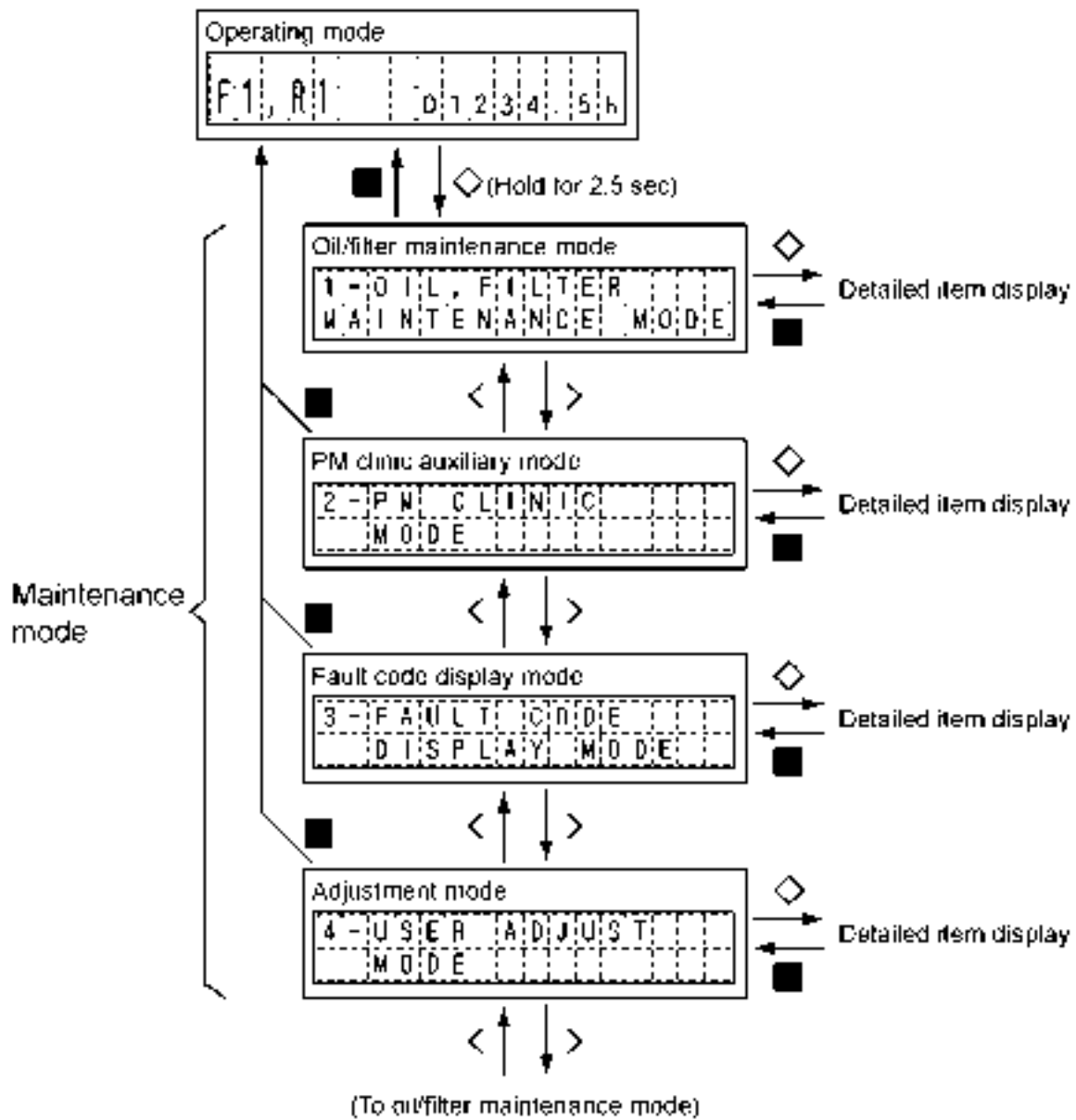

METHOD OF USING MAINTENANCE MODE

NOTICE

This function is only a guideline. If dirty oil or filters are found during daily maintenance, replace them immediately. If the controllers or monitor panel are replaced, the timer for this function will not work properly. Contact your Komatsu distributor for replacement.

The maintenance mode shows the replacement interval for the oil filters and oil on the monitor.

The content of the display is as follows.

- (1) The item is displayed.
- (2) The time remaining until replacement is displayed.
- (3) The number of times that replacement has been made until now is displayed.

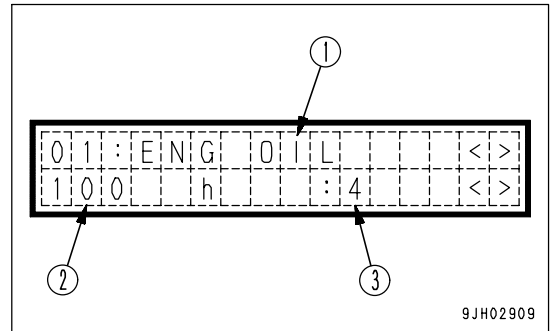

The display items can be displayed in order by operating the information switch to the left or right (<, >).

Code	Display	Item	Time to 1st replacement	Time to 2nd and following replacements
01	ENG.OIL	Engine oil	500h	500h
02	ENG.FLT	Engine oil filter	500h	500h
03	FUEL.FLT	Fuel filter	1000h	1000h
04	HYD.FLT	Hydraulic oil filter	250h	2000h
05	CORR.FLT	Corrosion resistor	1000h	1000h
06	BYPS.FLT	Bypass filter (*)	0h	0h
07	DAMP.OIL	Damper oil	2000h	2000h
08	OIL	Final drive oil	250h	1000h
09	HYD.OIL	Hydraulic oil	250h	2000h
10	POWL.OIL	Power train oil	250h	1000h
11	POWL.FLT	Power train oil filter	250h	500h
12	HSS.FLT	HSS charge filter (*)	0h	0h

(*) Although the marked item is displayed, it is not used with this machine.

When the oil or filter has been replaced, select the applicable item, then operate the buzzer cancel switch to ◇.

The screen will ask if you want to display the replacement history. Operate the information switch to select YES, then operate the buzzer cancel switch to ◇. The replacement account will increase by 1, the replacement interval will be reset, and the oil, filter change interval lamp will go out.

When this is done, if the maintenance caution lamp does not go out, there is another item close to the replacement time, so check the situation.

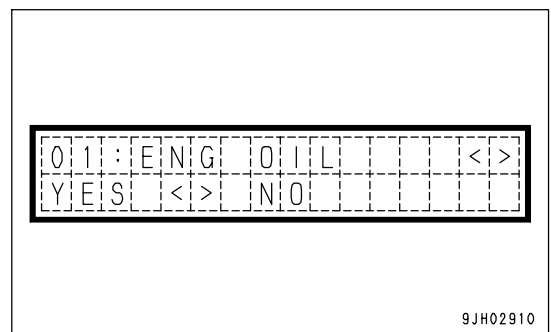

REMARK

To return to the maintenance mode, operate the buzzer cancel switch to ■.

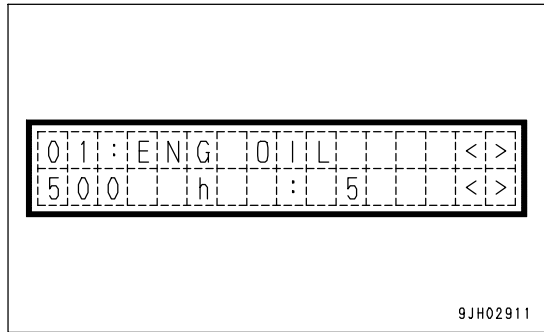

METHOD OF USING PM CLINIC AUXILIARY MODE

⚠ CAUTION

When moving the work equipment or setting the transmission to the travel position for carrying out measurements, check carefully that the situation is safe.

The PM clinic auxiliary mode displays the engine speed, hydraulic oil pressure, and other items on display panel B. Display panel B (Multi-information) displays the item on the top line (1) and the measured value on the bottom line (2).

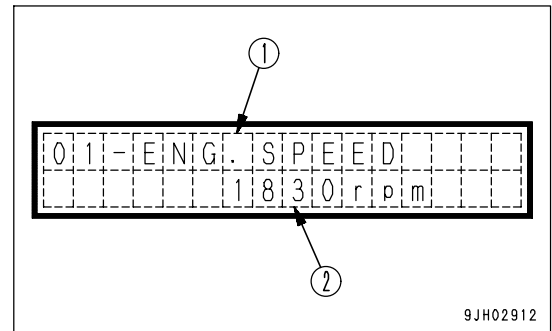

The display items consist of the six items in the table below. The items can be selected by operating the information switch (<, >).

Display	Item	Measured value
01-ENG.SPEED	Engine speed	Speed (rpm)
02-BOOST PRESSURE	Boost pressure	Pressure (kPa)
03-HYD.PUMP PRES	Hydraulic oil pressure	Pressure (MPa)
04-BATTERY VOLT	Battery voltage	Voltage (mV)

REMARK

- Items such as the engine speed fluctuate and are difficult to see during the measurement. In such cases, operate the buzzer cancel switch to ◊. This makes it possible to hold the display of the value.
- To cancel this mode, operate the buzzer cancel switch again to ◊.
- To return to the maintenance mode, operate the buzzer cancel switch to ■.

METHOD OF USING FAULT CODE DISPLAY MODE

NOTICE

The fault items observed by this function are connected with the electronic control, so even if a fault code is not displayed, there is probably some problem with the machine. If the operator feels any problem with the machine, the machine should be stopped immediately and checked.

When any disconnection or short circuit in any sensor is detected, the location and fault code are displayed by a 6-digit code on display panel B (multi-information). When contacting your Komatsu distributor, inform your distributor of the code at the same time.

If the failure observation function has not determined the condition of the machine, the display is as shown in the diagram on the right.

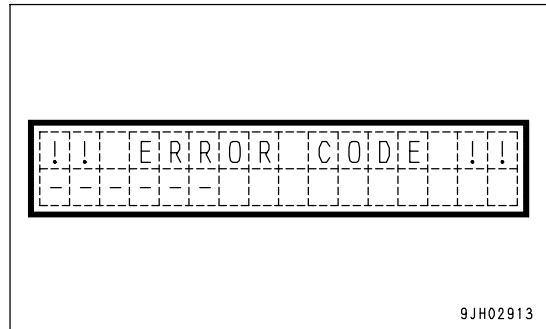

With this function, existing failures can be displayed up to a maximum of 20 items.

If multiple failures are occurring, the display automatically changes every 2 seconds, so check the code (1).

The display is shown repeatedly.

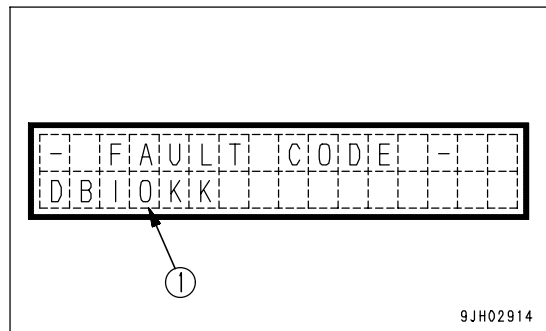

REMARK

To return to the maintenance mode, operate the buzzer cancel switch to ■.

METHOD OF USING USER ADJUST MODE

With the user adjust mode, the brightness of the panel screen backlighting and the contrast of the liquid crystal panel can be changed, or the cooling fan can be set to maximum speed to clean the radiator when it is clogged. These are displayed on display panel B.

1. Adjusting backlighting of liquid crystal display

- 1) The diagram on the right is the mode for adjusting the brightness of the backlighting of the liquid crystal panel. This display will be switched to the screen brightness adjustment display, if the alarm buzzer cancellation switch is turned to the \diamond position.

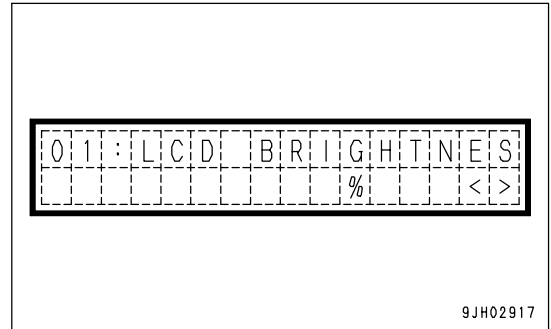

- 2) The brightness can be adjusted by operating the information switch. The higher the number, the brighter the screen becomes; the lower the number, the darker the screen becomes.
 - > position: Number increases
 - < position: Number decreases

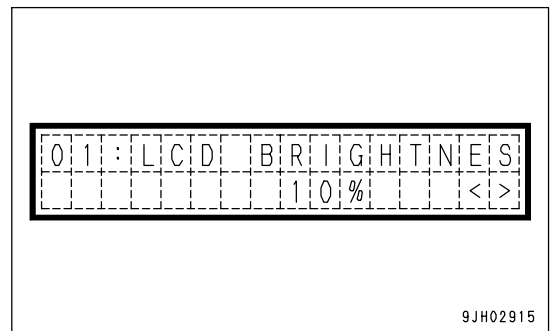

- 3) The brightness of the backlight for the LCD gauges may be held constant by turning the alarm buzzer cancellation switch to the \diamond position.

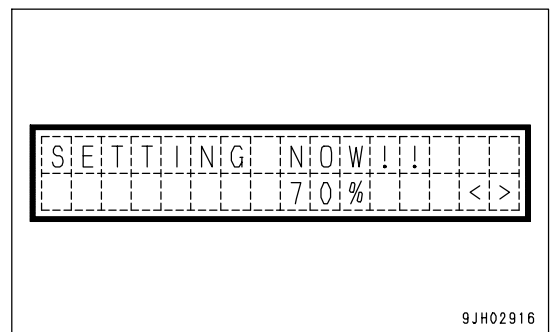

REMARK

- To return to the maintenance mode, operate the buzzer cancel switch to \blacksquare .
- The brightness of the backlighting of the monitor panel differs according to whether the front lamp is lit or not. Entering this mode when the front lamps are lit makes it possible to adjust the brightness when the front lamps are lit. In the same way, entering this mode when the front lamps are not lit makes it possible to adjust the brightness when the front lamps are not lit.

2. Adjusting backlighting of display panel B (multi-information)

1) The diagram on the right is the mode for adjusting the brightness of the backlighting of the display panel B (multi-information).

On the screen, operate the buzzer cancel switch to ◇ to switch to the screen for adjusting the brightness.

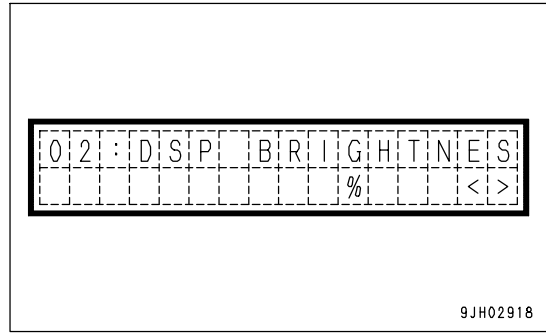

2) The brightness can be adjusted by operating the information switch.

The higher the number, the brighter the screen becomes; the lower the number, the darker the screen becomes.

> position: Number increases

< position: Number decreases

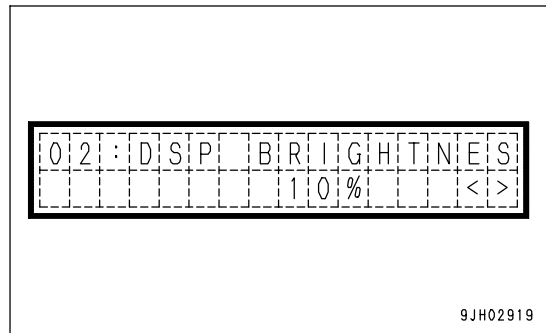

3) When the buzzer cancel switch is operated to ◇, the brightness of the display panel B (multi-information) backlighting is set.

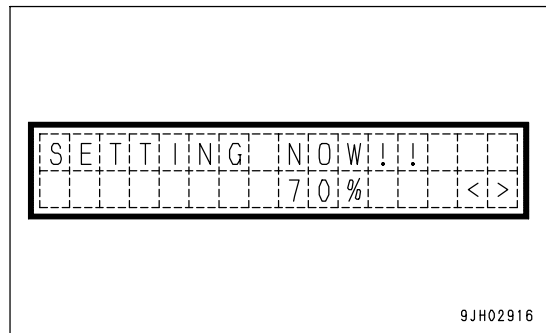

REMARK

- To return to the maintenance mode, operate the buzzer cancel switch to ■.
- The brightness of the backlighting of the monitor panel differs according to whether the front lamp is lit or not. Entering this mode when the front lamps are lit makes it possible to adjust the brightness when the front lamps are lit. In the same way, entering this mode when the front lamps are not lit makes it possible to adjust the brightness when the front lamps are not lit.

3. Adjusting contrast of liquid crystal display panel B (multi-information)

1) The diagram on the right is the mode for adjusting the contrast of the liquid crystal display panel B (multi-information).

On this screen, operate the buzzer cancel switch to ◇ to switch to the screen to adjust the contrast.

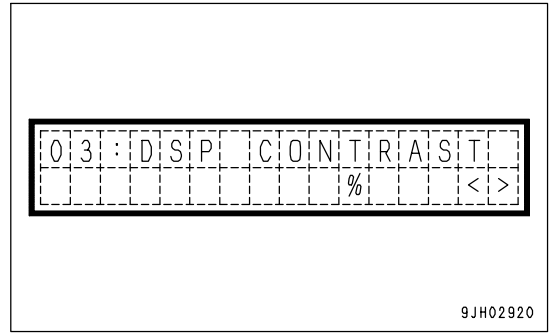

2) The contrast can be adjusted by operating the information switch.

The higher the number, the deeper the screen becomes; the lower the number, the lighter the screen becomes.

> position: Number increases

< position: Number decreases

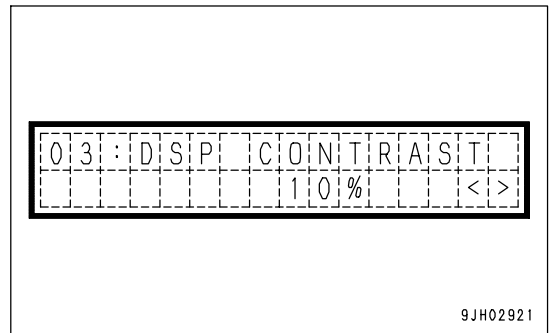

3) When the buzzer cancel switch is operated to ◇, the contrast of the liquid crystal display panel B (multi-information) is set.

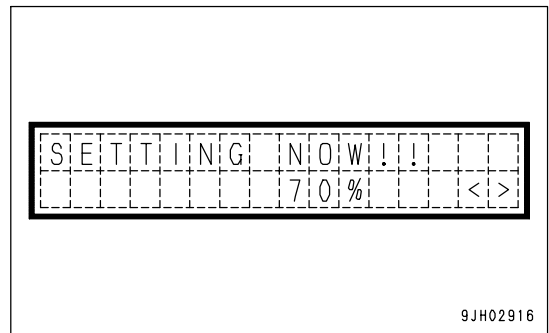

4. Mode to rotate cooling fan at maximum speed

The diagram on the right is the mode for rotating the cooling fan at maximum speed. On this screen, operate the buzzer cancel switch to ◇ to rotate the cooling fan at the maximum speed.

Note that this mode is effective only when the display in the diagram on the right is being given. After leaving this mode, the screen returns to the normal mode.

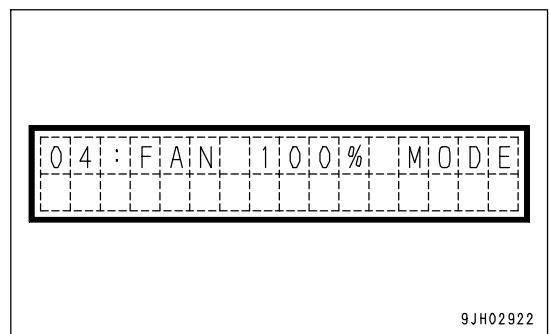

REMARK

- To return to the maintenance mode, operate the buzzer cancel switch to ■.
- The brightness of the backlighting of the monitor panel differs according to whether the front lamp is lit or not. Entering this mode when the front lamps are lit makes it possible to adjust the brightness when the front lamps are lit. In the same way, entering this mode when the front lamps are not lit makes it possible to adjust the brightness when the front lamps are not lit.

SWITCHES

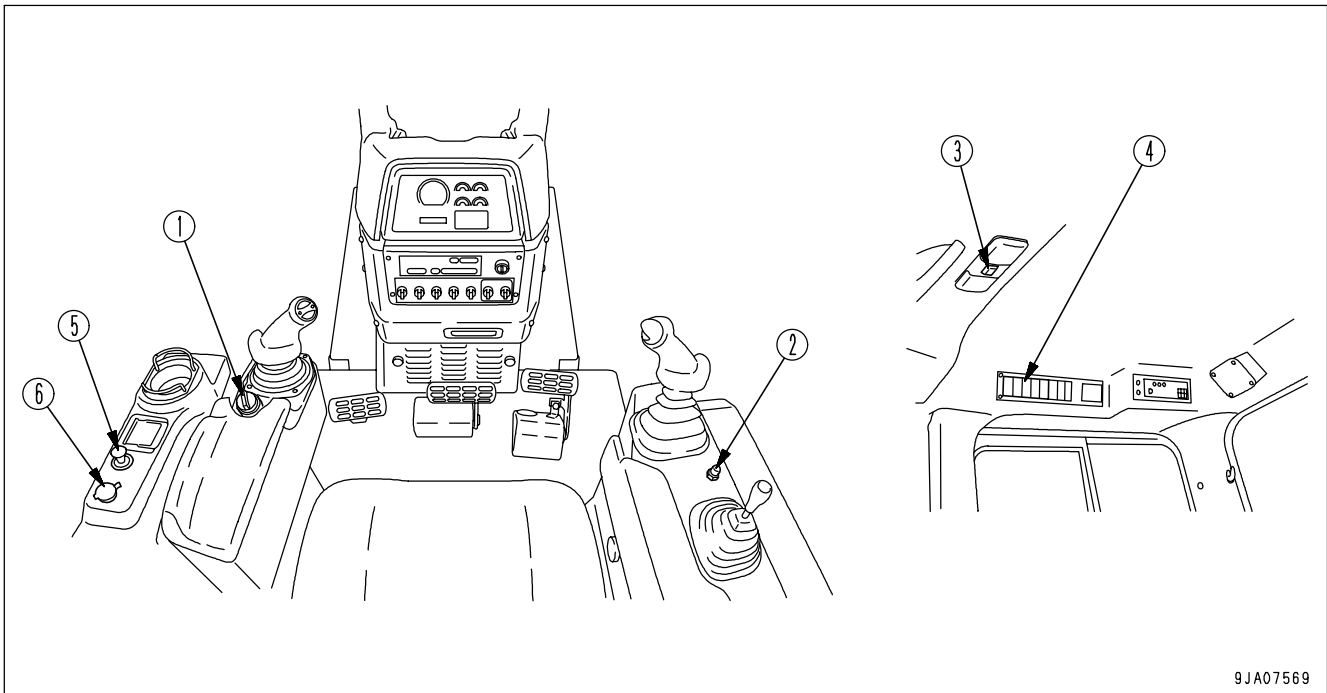

9JA07569

- | | |
|-----------------------|-----------------------|
| (1) Fuel control dial | (4) Wiper switch |
| (2) Horn switch | (5) Cigarette lighter |
| (3) Room lamp switch | (6) Accessory socket |

FUEL CONTROL DIAL

Dial (1) is used to control the engine speed and output.

- (a) Low idling position: Turn fully to the left
 (b) High idling position: Turn fully to the right

REMARK

To stop the engine, turn the starting switch to the OFF position.

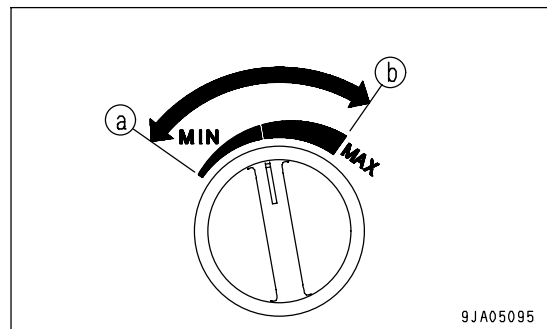

9JA05095

HORN SWITCH

The horn sounds when the button (2) at the rear of the blade control lever at the right side of the operator's seat is pressed.

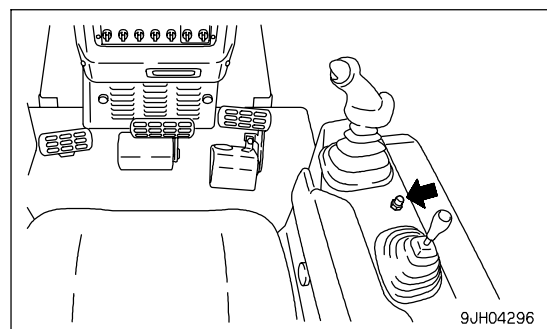

9JH04296

ROOM LAMP SWITCH

This (3) illuminates the room lamp.
 OFF position: Lamps are out
 ON position: Lamps light up

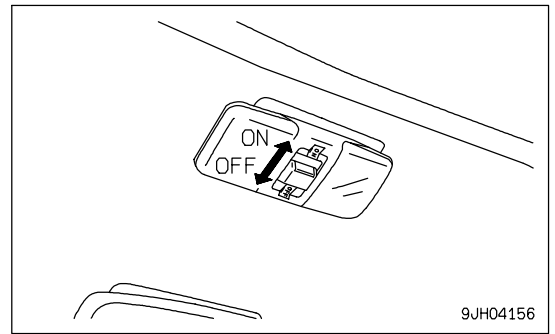

9JH04156

WIPER SWITCH

This (4) activates the wipers.
 The wiper switches are as follows:
 (LH) Left door
 (FF) Front window
 (RH) Right door
 (RR) Rear window
 (INT) Wiper intermittent operation switch

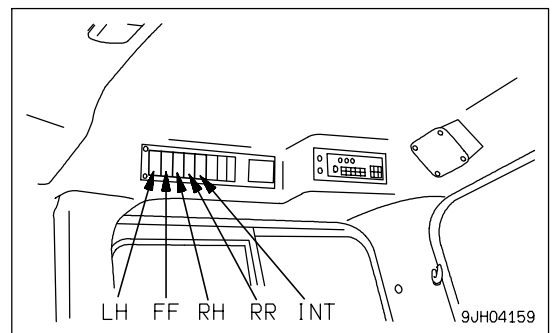

9JH04159

This is also used as the window washer switch.
 The switch is operated as follows.

- Wiper only
 - ON position: Wiper is operated
 - OFF position: Wiper stops

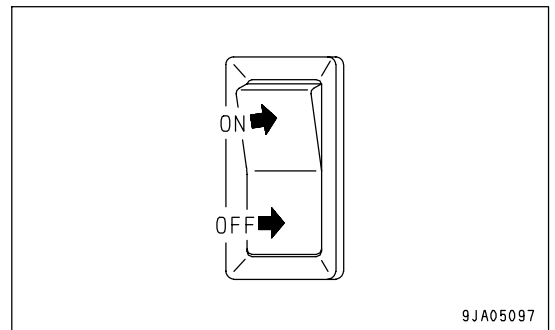

9JA05097

- Wiper and window washer
 - If this is kept pressed to the ON position while the wiper is working, water will be sprayed out.

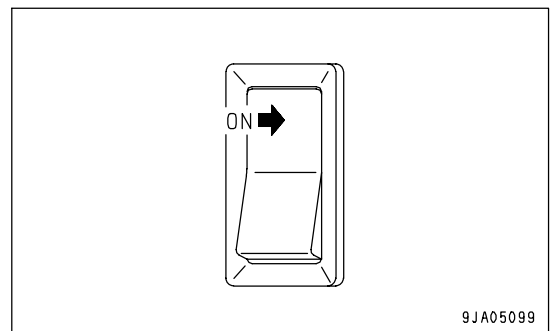

9JA05099

- Window washer only
Keep the switch pressed to the OFF position to spray out water.

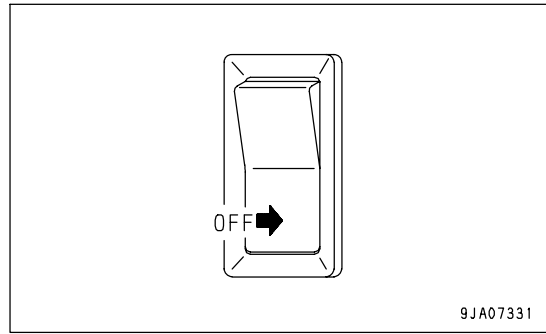

- Wiper intermittent operation switch
If the wiper is operated with the switch at the ON position, the wiper will move once every four seconds.

REMARK
When the wiper intermittent operation switch is ON, if the wiper switch for each window is turned ON, the wiper will move intermittently.

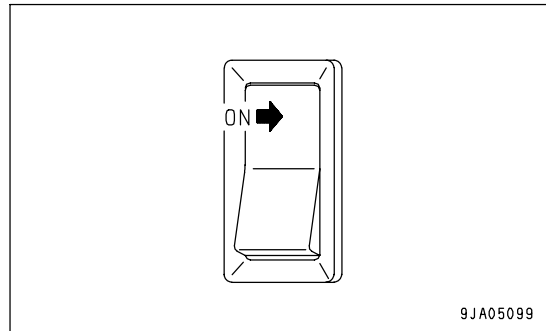

REMARK
When installing the cab, check the colors of the washer tank and window washer hoses, and be sure to connect correctly.

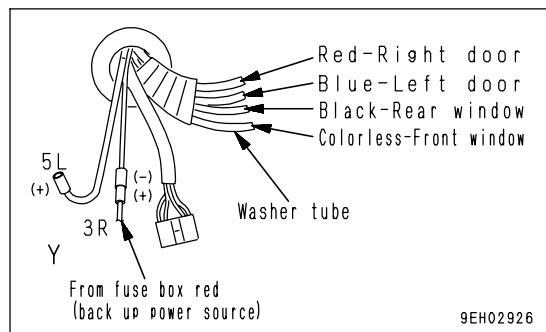
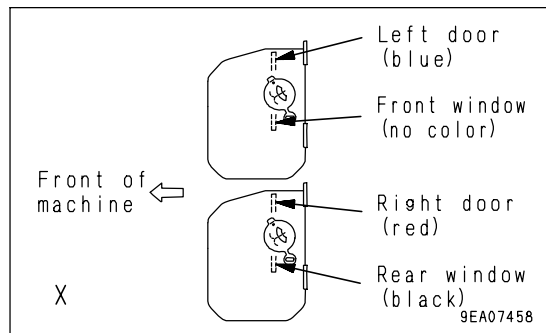
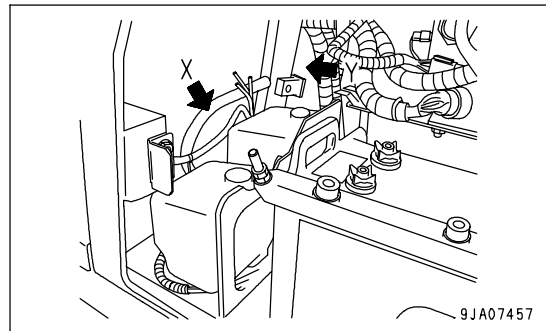

CIGARETTE LIGHTER

This (5) is used to light cigarettes.

When the cigarette lighter is pushed in, it will return to its original position after a few seconds, so take it out to light your cigarette. If the cigarette lighter is removed, the socket can be used as a power source.

NOTICE

This cigarette lighter is 24V. Do not use it as the power supply for 12V equipment. This will cause failure of the equipment.

The capacity of the cigarette lighter is 120W (24V x 5A).

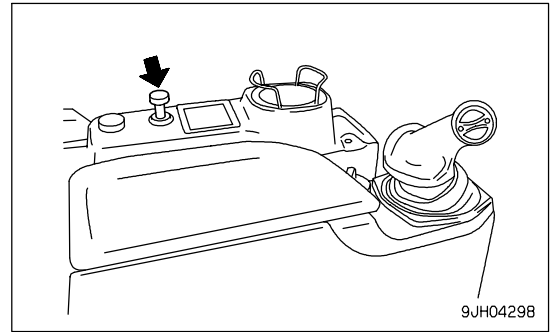
**ACCESSORY SOCKET**

This (6) is used as the power source for a wireless or other 12V equipment.

Accessory socket capacity: 60W (12V x 5A)

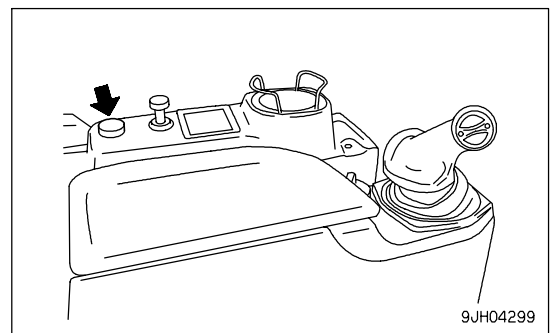

CONTROL LEVERS, PEDALS

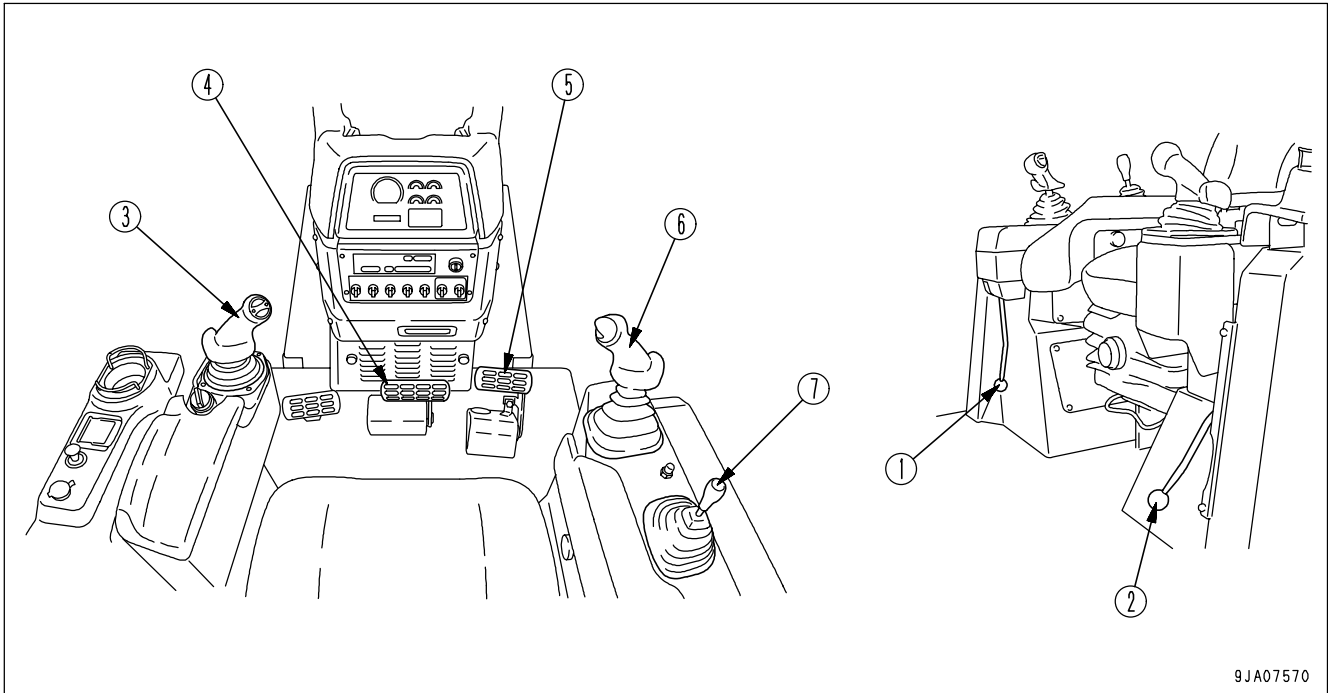

9JA07570

- | | |
|-----------------------------------------------------------|--------------------------|
| (1) Work equipment lock lever | (4) Brake pedal |
| (2) Parking brake lever | (5) Deceleration pedal |
| (3) Joystick (steering, directional and gear shift lever) | (6) Blade control lever |
| | (7) Ripper control lever |

WORK EQUIPMENT LOCK LEVER

 **WARNING**

- When leaving the operator's compartment, set the work equipment lock lever securely to the LOCK position. If the work equipment lock lever is not at the LOCK position and the control levers are touched by mistake, it may lead to serious personal injury.
- If the work equipment lock lever is not set securely to the LOCK position, the work equipment may move and cause serious injury. Check that it is in the position shown in the diagram.
- When parking the machine or when carrying out maintenance, always lower the work equipment to the ground, then set the work equipment lock lever to the LOCK position.

This lever (1) is a lock device for the blade control lever and ripper control lever.

When it is set to the LOCK position, operation of the work equipment is locked.

REMARK

When starting the engine, to ensure safety, always set the work equipment lock lever to the LOCK position.

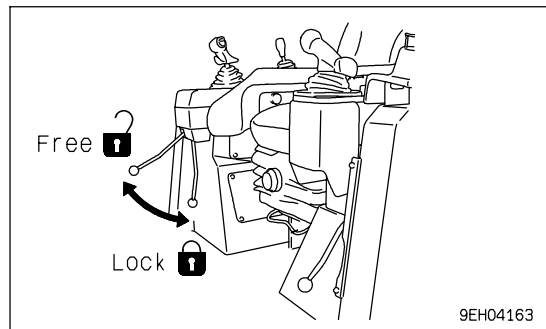

9EH04163

PARKING BRAKE LEVER

**WARNING**

- When parking the machine, always set the parking brake lever in the LOCK position.
- If the parking brake lever is operated, the brake is applied, even when the machine is traveling. The machine will suddenly stop, so this is dangerous. For this reason, do not operate the parking brake lever when the machine is moving, except in emergencies.

This lever (2) operates the parking brake. The parking brake is applied when it is in the LOCK position.

REMARK

- Before moving the parking brake lever to the LOCK position, return the steering, forward-reverse, gear shift lever to the NEUTRAL position.
- When starting the engine, if the parking brake lever is not in the LOCK position, the limit switch is actuated and it is impossible to start the engine.

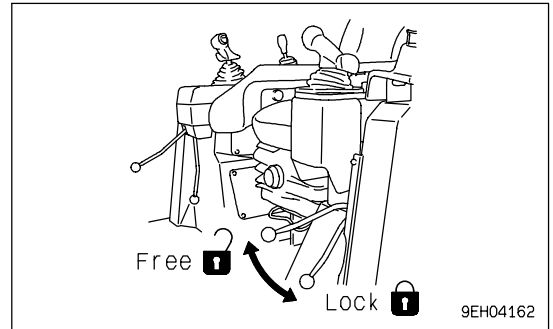
**JOYSTICK (STEERING, DIRECTIONAL AND GEAR SHIFT LEVER)**

This control lever (3) serves to change forward or reverse direction of machine travel, steer the machine to the right or left, change the traveling speed and make a counter-rotation.

- **Forward-reverse shifting**

Position (a): FORWARD

Position (b): REVERSE

Position N: Neutral

Move to the front to drive forward; move to the rear to drive in reverse.

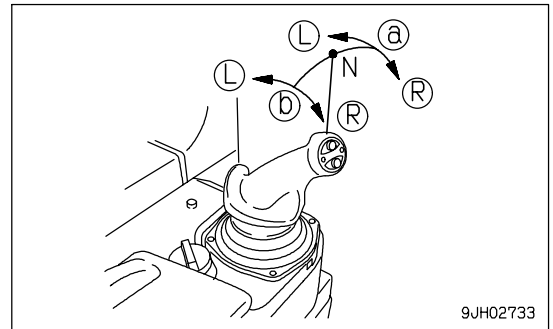

- **Steering**

Position (L): Left turn

Position (R): Right turn

With the lever moved to the front or rear, operate the lever partially to the left or right to turn the machine. The machine will turn gradually in the same direction as the lever is operated.

If the lever is moved fully to the left or right, the machine will turn in a small radius.

REMARK

When moving the joystick lever, and the lever is released, it will return to (a) or (b) and the machine will travel in a straight line.

• Gear shifting

When the steering, directional, and gearshift lever is at the FORWARD or REVERSE position and switch (c) or switch (d) is pushed, the transmission speed will change.

UP switch (c): Each time the switch is pressed, the transmission will shift up one speed.

DOWN switch (d): Each time the switch is pressed, the transmission will shift down one speed.

For details of the maximum speed in each speed range, see "SPECIFICATIONS (PAGE 5-2)".

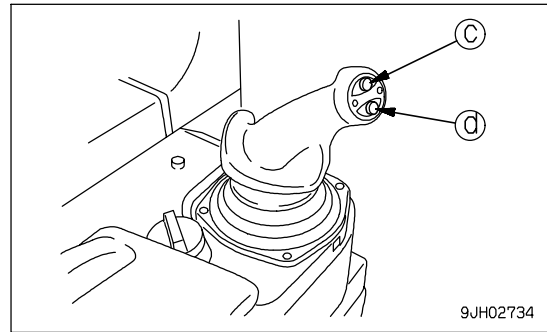

9JH02734

REMARK

The speed range being used is displayed on panel A on the monitor panel according to the gearshift operation.

<Example>

Neutral: N is displayed on the display panel.

FORWARD 2nd: F2 is displayed on the display panel.

REVERSE 3rd: R3 is displayed on the display panel.

When the parking brake lever is locked, P is displayed.\T

- For details of the method of shifting gears according to the shift mode, see the "SHIFTING GEAR (PAGE 3-107)". Shift mode selection means that the selected speed range is displayed at the NEUTRAL position (N) before starting.

• Operating counter-rotation turn



WARNING

When operating the counter-rotation turn, if the load on the left and right is not balanced, the machine may make a pivot turn, so check the ground conditions and be careful not to hit any obstacles when carrying out the operation.

With the lever in the N position, move the lever partially in the direction of turn. The left and right tracks will rotate in opposite directions, and the machine will make a slow counter-rotation turn. If the lever is moved further, the speed of the counter-rotation turn will increase.

(R): Right counter-rotation turn

(L): Left counter-rotation turn

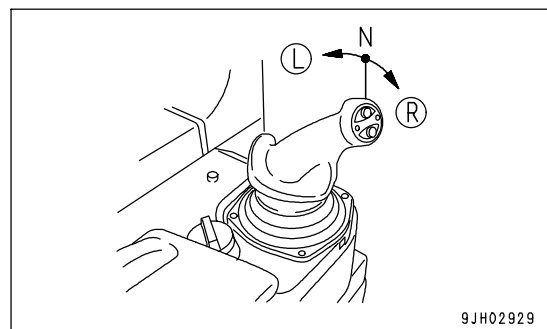

9JH02929

BRAKE PEDAL

**WARNING**

Do not place your foot on this pedal unnecessarily.

Depress the pedal (4) to apply the right and left brakes.

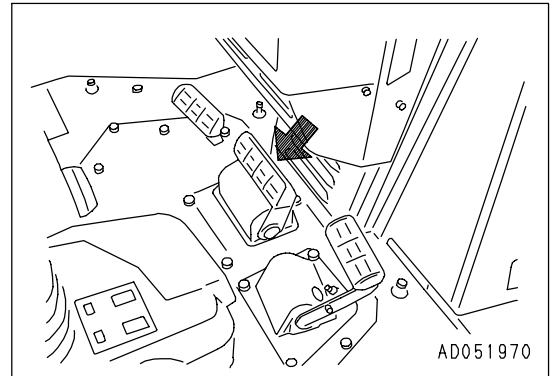

DECELERATOR PEDAL

**WARNING**

- Do not rest your foot on the pedal if you are not using it.
- When passing over the top of a slope or when dumping soil from a cliff, the load on the machine will suddenly be reduced and the travel speed will increase. This situation is dangerous, so use the decelerator pedal to reduce the travel speed of the machine

This pedal (5) is used when reducing the engine speed or stopping the machine.

When switching between forward and reverse, or when stopping the machine, use this pedal to reduce speed.

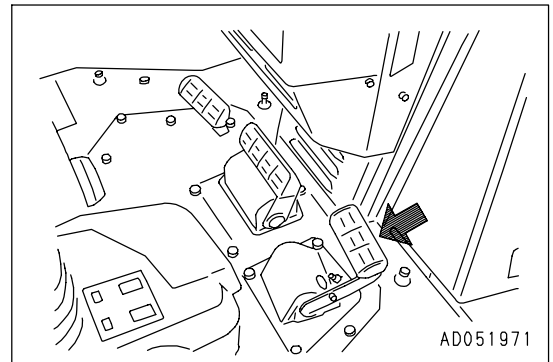

BLADE CONTROL LEVER

FOR POWER TILT DOZER

This lever (6) is used to lift or tilt the blade.

- Lifting control

- (a) RAISE:
- (b) HOLD: Blade is stopped and held in this position.
- (c) LOWER:
- (d) FLOAT: Blade will move freely according to external force.

REMARK

- If the lever is in the FLOAT position, even when it is released, it does not return to the HOLD position, so return it by hand.
- If the engine is stopped when the control lever is in the FLOAT position, the lever is returned automatically to the HOLD position.
- In low temperatures, it may take a short time for the blade control lever to be held in the FLOAT position, so hold the lever in position for at least 1 second.

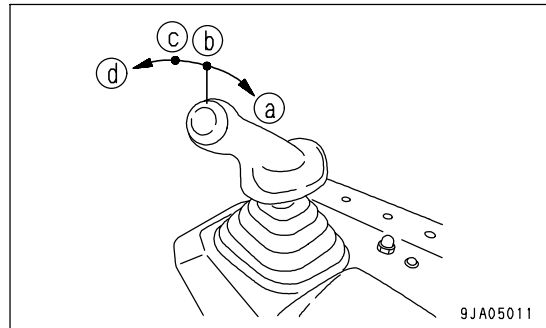

9JA05011

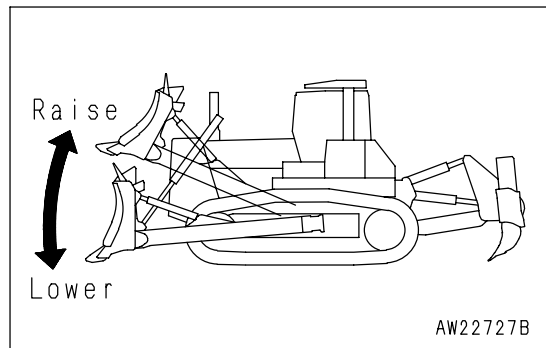

AW22727B

- Tilting control

- (b) HOLD: Blade is stopped and held in this position.
- (e) LEFT TILT
- (f) RIGHT TILT

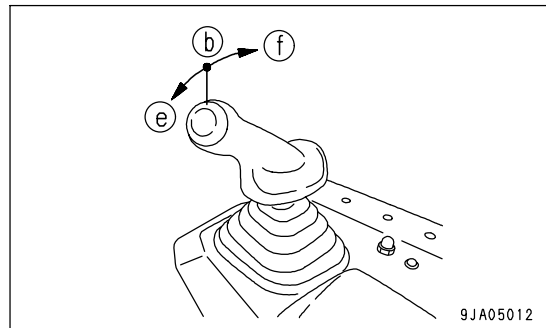

9JA05012

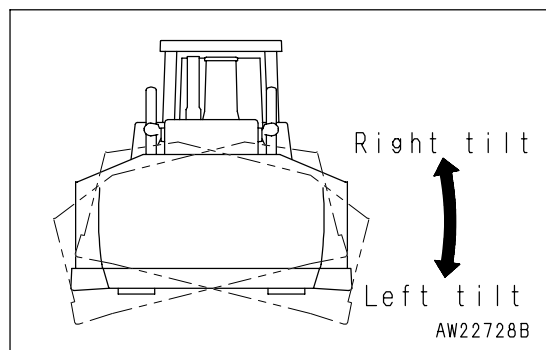

AW22728B

SINGLE TILT DOZER

This lever (6) is used to lift the blade.

- Lifting control

- (a) RAISE:
- (b) HOLD: Blade is stopped and held in this position.
- (c) LOWER:
- (d) FLOAT: Blade will move freely according to external force.

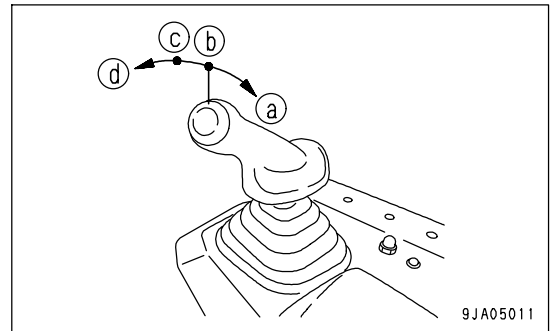

9JA05011

REMARK

- If the lever is in the FLOAT position, even when it is released, it does not return to the HOLD position, so return it by hand.
- If the engine is stopped when the control lever is in the FLOAT position, the lever is returned automatically to the HOLD position.
- In low temperatures, it may take a short time for the blade control lever to be held in the FLOAT position, so hold the lever in position for at least 1 second.

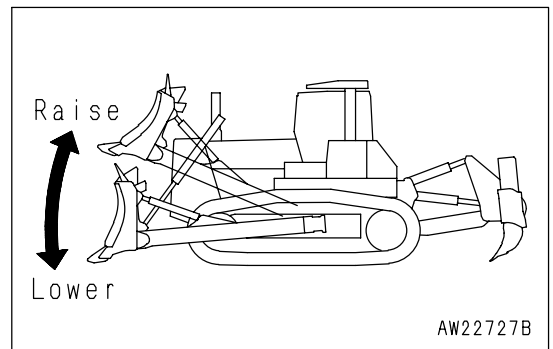

AW22727B

RIPPER CONTROL LEVER

This lever (7) is used to operate the ripper.

FIXED MULTI-SHANK RIPPER SPECIFICATION

- (a) RAISE
- (b) HOLD: Ripper is stopped and held in the same position.
- (c) LOWER

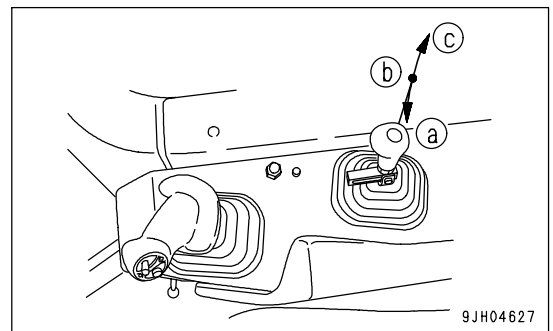

9JH04627

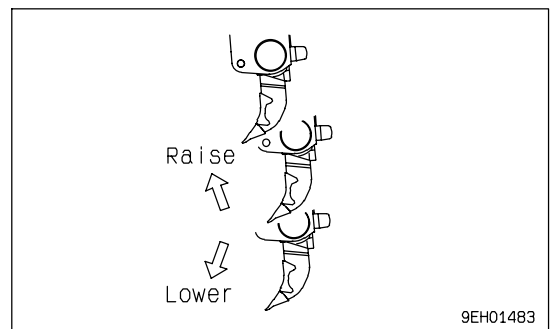

9EH01483

VARIABLE MULTI-SHANK RIPPER SPECIFICATION

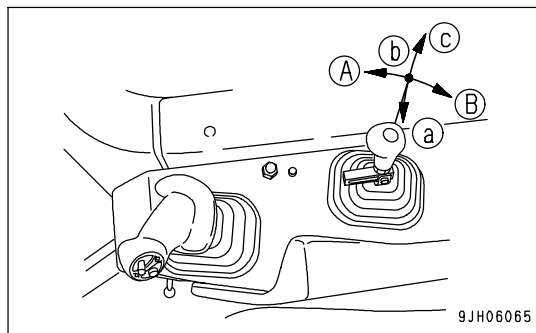

• Lift operation

- (a) RAISE
- (b) HOLD: Ripper is stopped and held in the same position.
- (c) LOWER

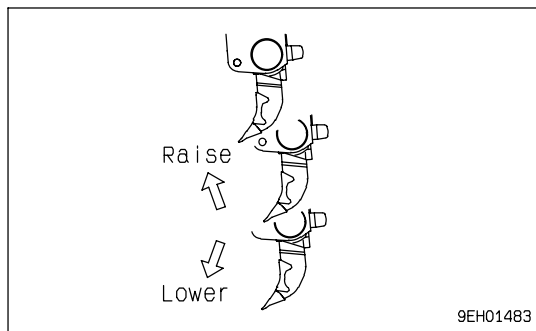

• Tilt operation

- (A) Tilt in
- (B) Tilt back

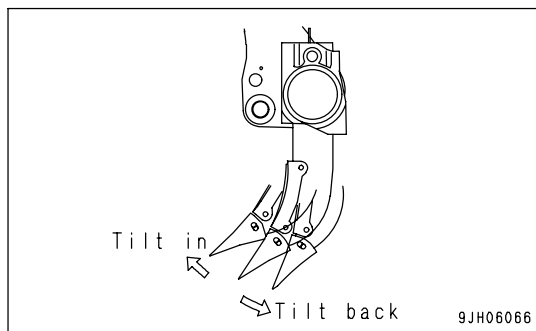

FUSE

NOTICE

Before replacing a fuse, be sure to turn starting switch to the OFF position.

The fuses protect the electrical equipment and wiring from burning out.

If the fuse becomes corroded, or white powder can be seen, or the fuse is loose in the fuse holder, replace the fuse.

Replace the fuse with another of the same capacity.

- Chassis

Open the battery cover. Fuse boxes (A) and (B) and main power circuit breakers (1) and (2) are installed inside.

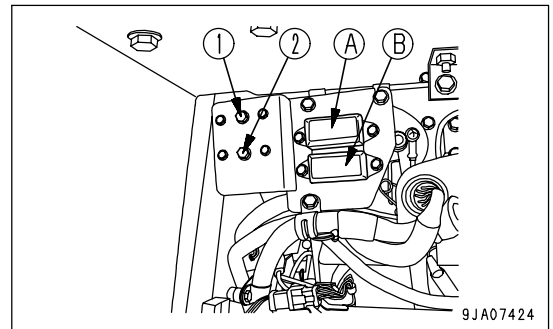

- Cab (machines equipped with cab)

Fuse box (C) is installed in the overhead panel.

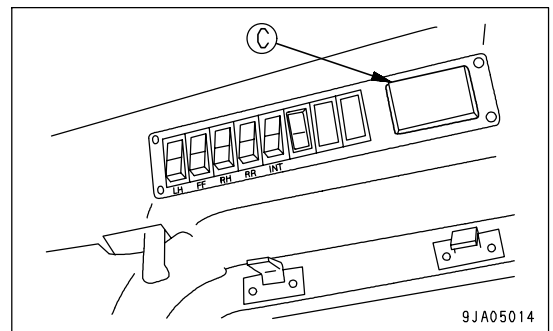

FUSE CAPACITY AND CIRCUIT NAME

Fuse box (A)

No.	Fuse capacity	Circuit
1	30A	Additional heater, Spere power source
2	20A	Horn, Intake air heater
3	20A	Head lamp
4	20A	Rear lamp
5	20A	Transmission Steering controller

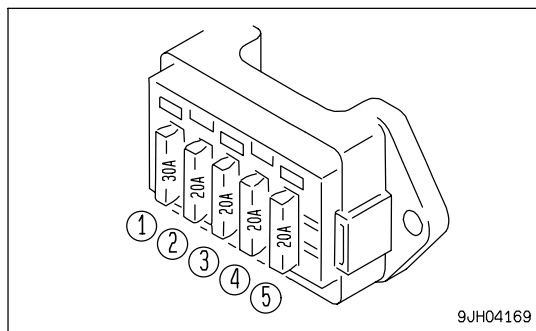

Fuse box (B)

No.	Fuse capacity	Circuit
(1)	15A	Monitor panel
(2)	20A	Fuel pump
(3)	30A	Air conditioner
(4)	20A	Backup alarm
(5)	30A	Battery power source (direct from battery)

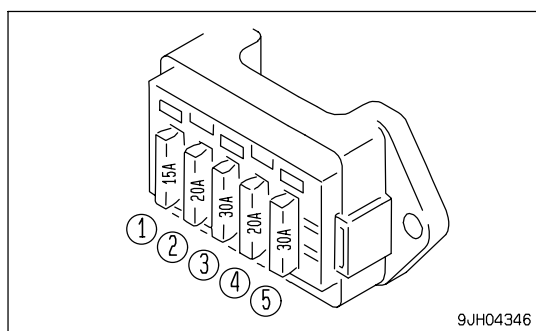

Fuse box (C)

No.	Fuse capacity	Circuit
(1)	10A	Radio memory
(2)	20A	Radio, lamp, cigarette lighter
(3)	20A	Heated wire glass (If equipped)
(4)	10A	Rear wiper
(5)	10A	Front wiper
(6)	10A	Left and right door wiper

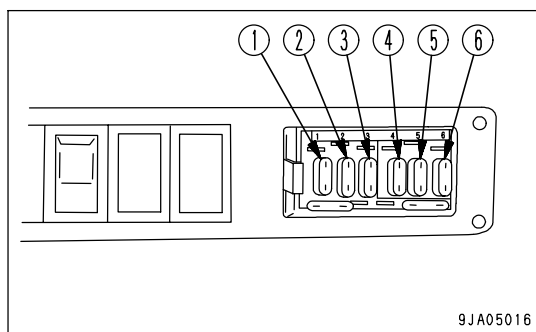

MAIN POWER CIRCUIT BREAKERS

- If the starting motor is not actuated even when the starting switch is turned to the ON position, open the battery cover at the rear left side of the machine, and inspect circuit breakers (1) and (2).

Circuit breakers (1) and (2) also act as the reset button.

- If there is a surge of current, the circuit breaker shuts off the circuit to protect the electrical components and wiring from damage.
- Turn the starting switch to the OFF position and reset the circuit breaker.
- When resetting the electrical circuit after it has been shut off, press the reset button 5 to 10 minutes after the circuit has been shut off. When the electrical circuit has been shut off, the operation of the reset button is heavier than when the circuit is normal. The height of the reset button is the same, regardless of whether the circuit has been shut off or has been reset, so make note of the effort of the reset button when resetting the circuit.
- Do not keep the circuit breaker reset button longer than necessary.
- If the starting motor does not work even when the circuit breaker has been reset, contact your Komatsu distributor.

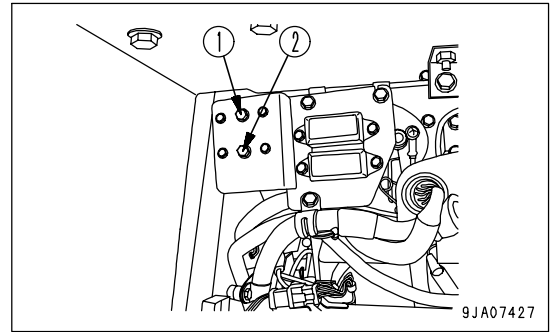

No	Fuse capacity	Circuit
(1)	105A	General power supply
(2)	30A	Permanent power supply for cab

CIRCUIT BREAKER

- If the starting switch does not work even when the starting switch is turned to the ON position, open the recirculated air filter cover to gain access to the circuit breaker.
- If excessive current flows through the circuit breaker, it cuts off the electric circuit to prevent damage to the electrical components and wiring.
- To restore the electric circuit after it has been cut off, push in reset button (3). (This springs out when the circuit is cut off.) If the electric circuit is normal, reset button (3) will stay pushed in. If it comes out immediately when it is pushed in, the electric circuit must be checked.

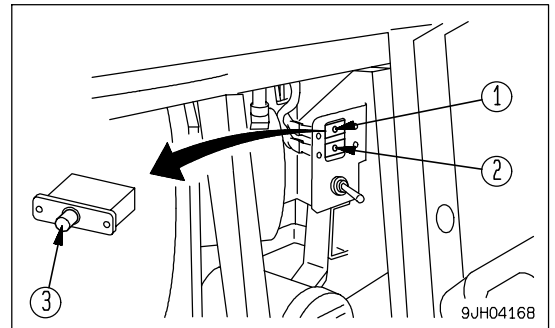

Circuit breakers (1) and (2) also act as reset button (3).

No	Fuse capacity	Circuit
(1)	20A	Starting switch
(2)	20A	Air conditioner

REMARK

The circuit breaker is a device installed in electric circuits where a large current flows. It is installed to protect the electric circuit. It protects the electric components and wiring from damage caused by an abnormal current in the same way as a normal fuse. After repairing and restoring the location of the abnormality, there is no need to replace the breaker. It can be used again.

POWER SOURCE

NOTICE

The power for the cigarette lighter is 24V. Do not use it as the power source for 12V equipment.

The cigarette lighter socket (1) can be used as a power source for 24V equipment and the accessory socket (2) can be used for 12V equipment.

Capacity of cigarette lighter : 120W (24V x 5A)

Capacity of accessory socket : 60W (12V x 5A)

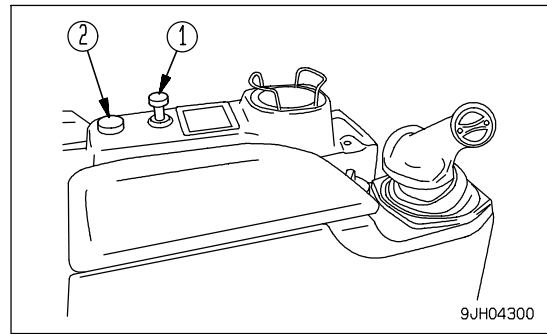

CAP WITH LOCK

Lock-type caps are available for the radiator water filler cap, hydraulic tank oil filler cap, and fuel tank filler cap. For details of the locations of the caps with locks, see "LOCKING (PAGE 3-126)".

Use the starting switch key to open and close the locks on the caps.

METHOD OF OPENING RADIATOR CAP AND FUEL CAP

(If equipped)

OPENING THE CAP

1. Insert the key. Make sure that you have inserted the key fully (1) before turning it. If the key is turned when only partially inserted, it may break.

(L) : Lock position

(F) : Open position

(A) : working angle of key 180°

(B) : 45°

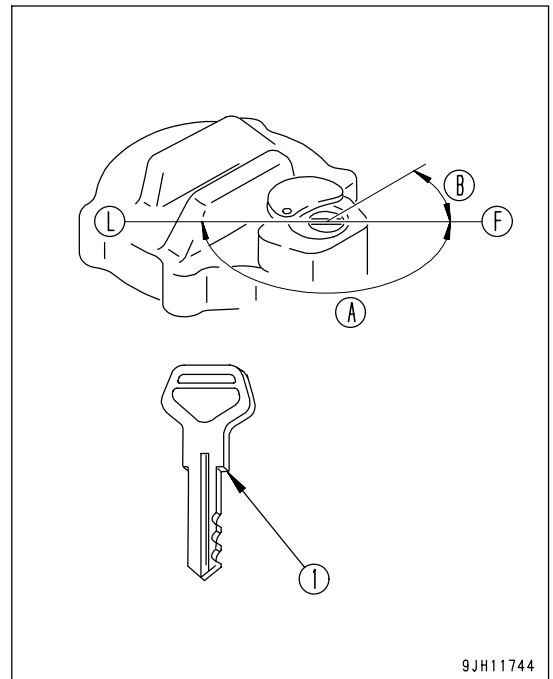

2. Turn the key counterclockwise to align the match mark (2) on the cap with the rotor groove, then turn the cap slowly. When a click is heard, the lock is released, enabling the cap to be opened.

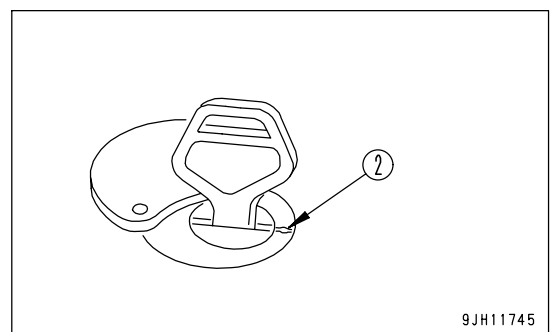

LOCKING THE CAP

1. Turn the cap into place.
2. Turn the key clockwise and take the key out.

METHOD OF OPENING HYDRAULIC CAP**OPENING THE CAP**

1. Insert the key. Make sure that you have inserted the key fully (1) before turning it. If the key is turned when only partially inserted, it may break.

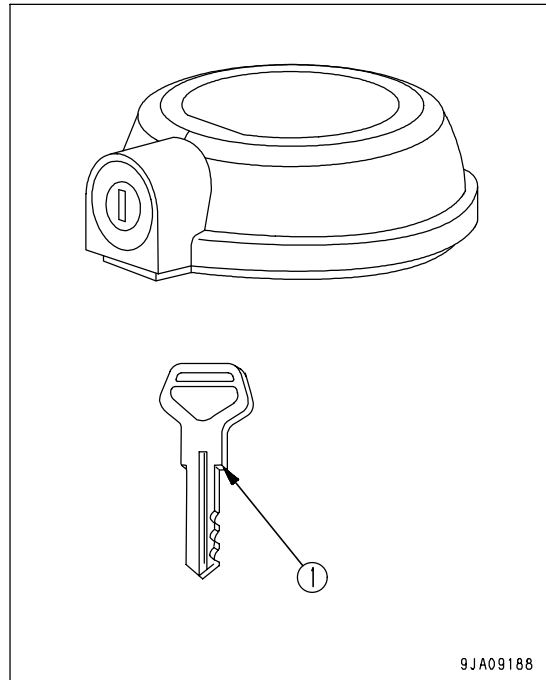

2. Turn the key counterclockwise 180° in direction (A). The cap can then be opened.

(A): Open
(B): Lock

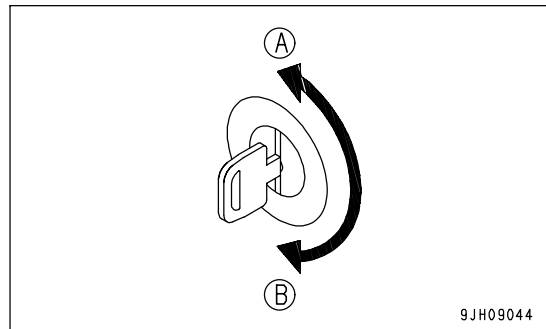
**LOCKING THE CAP**

1. Insert the key.
2. Turn the key clockwise in direction (B), then remove the key.

DOOR OPEN LOCK

Use this when you want to keep the door held open.

1. Push the door against door catch (1). The door will be held by the door catch.

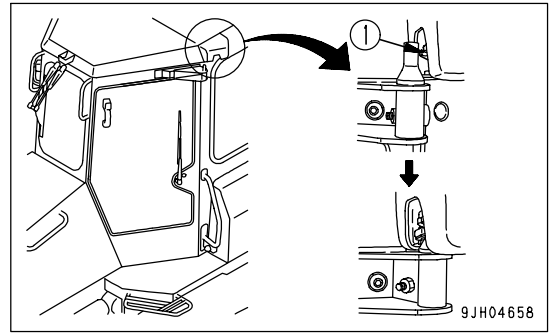

2. To release the door, move lever (2) inside the cab forward. This will release the catch.

NOTICE

- When keeping the door open, fix it securely to the catch.
- Always close the door when traveling or carrying out operations. Leaving the door open will cause the door to break.
- Keep the door locked open securely. The door may swing closed because of the vibration.

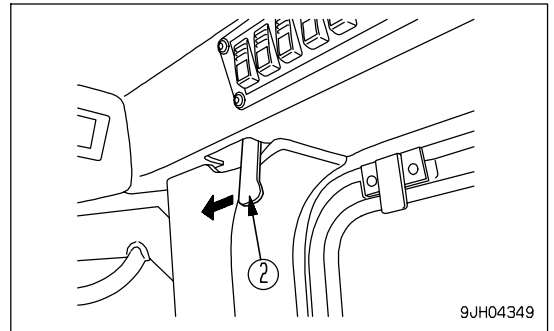

SASH GLASS INTERMEDIATE LOCK

When working with the cab sash glass open, use this lock to prevent the glass from chattering.

- When the lever is in the FREE position, the glass can be opened or closed.
- When the lever is in the LOCK position, the glass is held in position.

NOTICE

Always close the window when traveling or carrying out operations. Leaving the window open will cause the window to break.

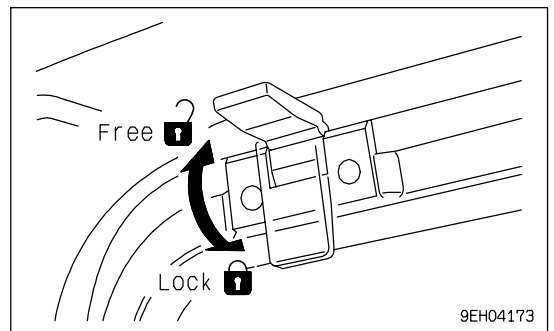
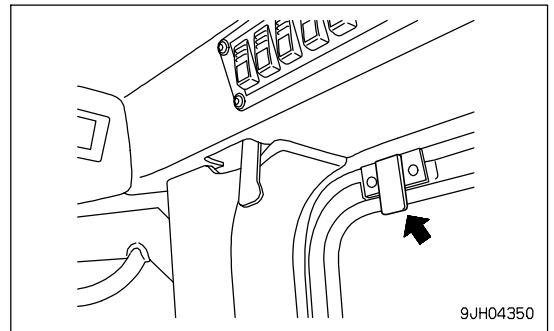

DOOR POCKET

This is inside the left and right doors. Use it for storing the Operation and Maintenance Manual or other things.

Do not put heavy tools or other heavy objects in it.

If the pocket is dirty, turn 4 clips (1), then remove the pocket and rinse it.

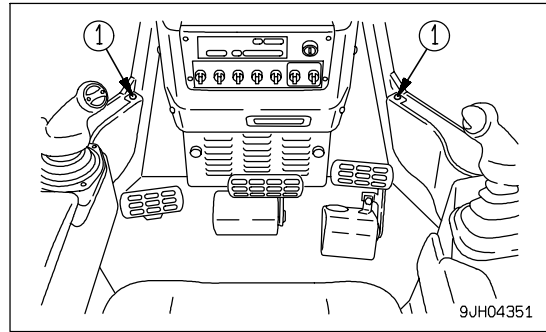

ASHTRAY

This is on the left side of the operator's seat.

Always make sure that you extinguish the cigarette before closing the lid.

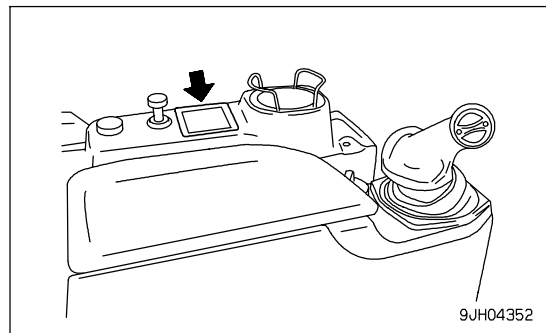

TOOL BOX

(If equipped)

Open the engine side cover on the right side of the machine. The toolbox is inside the bottom engine side cover.

Store the tools in this box.

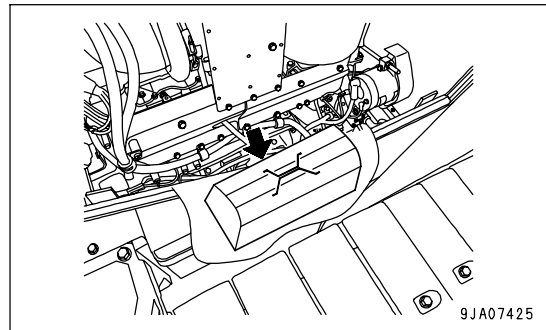

AIR CONDITIONER

(Machine equipped with cab)

GENERAL LOCATIONS AND FUNCTION OF CONTROL PANEL

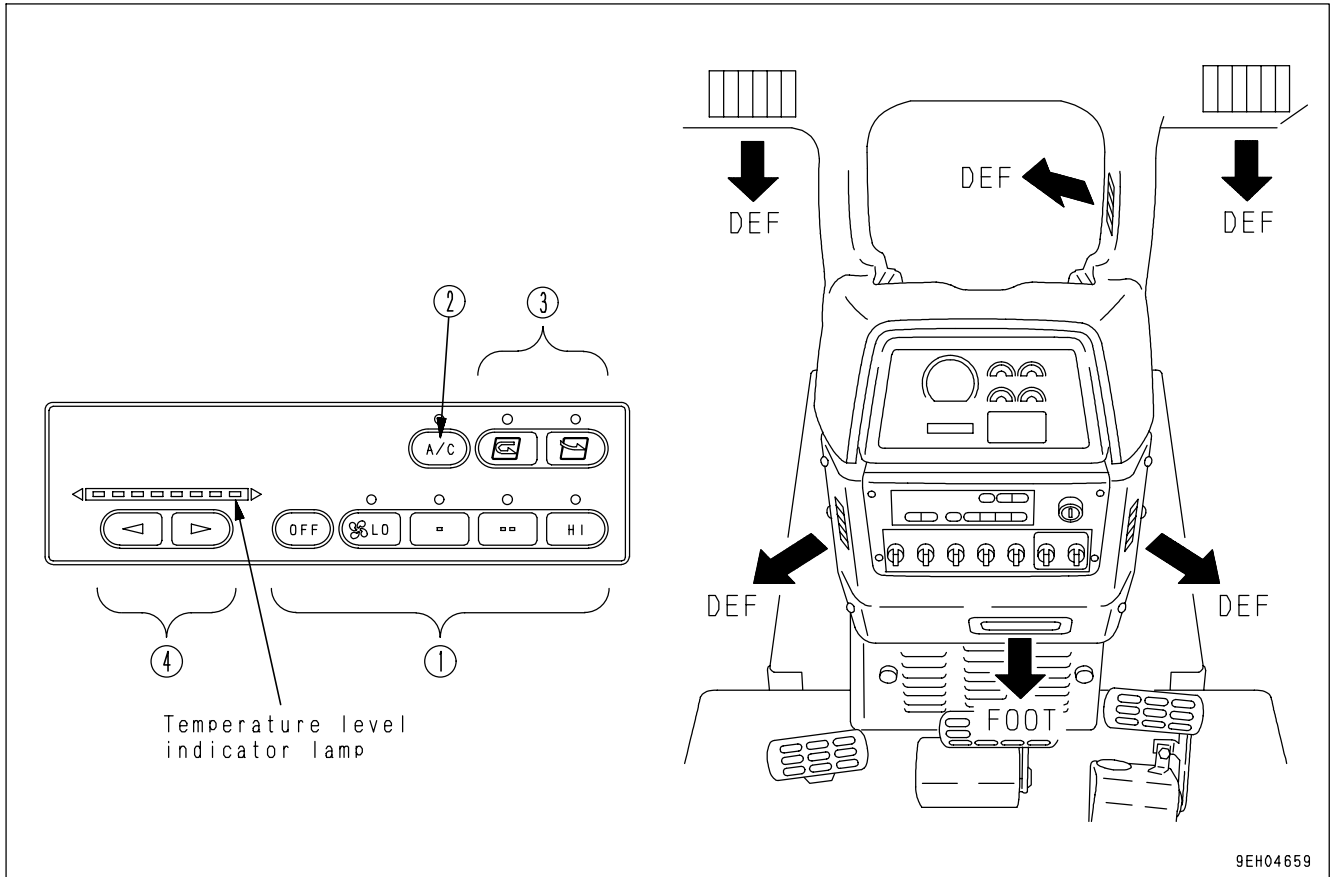

9EH04659

- (1) Fan switch
- (2) Air conditioner switch
- (3) Fresh/recirc selector switch
- (4) Temperature control switch

FAN SWITCH

This switch (1) can be used to adjust the airflow in four stages. It also acts as the main switch for the air conditioner. When the OFF switch is pressed, the fan stops. When the switch is pressed, the indicator lamp above the switch lights up to display the airflow.

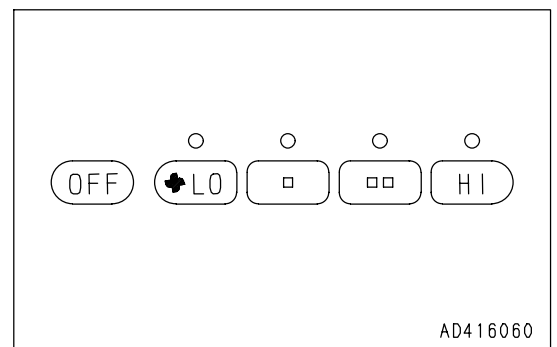

AD416060

AIR CONDITIONER SWITCH

This switch (2) is used to start or stop the cooling or dehumidifying function.

When the fan switch is turned ON and the air conditioner switch is pressed, the indicator lamp above the switch lights up. When the switch is pressed again, the switch is turned OFF and the indicator lamp goes out.

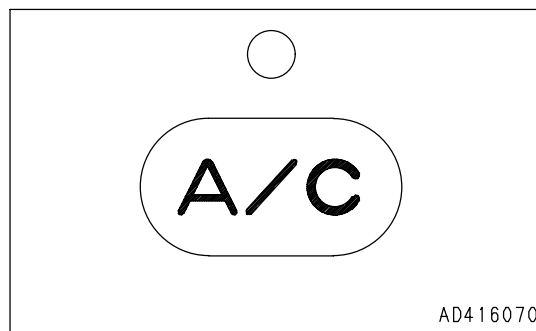
**FRESH/RECIRC SELECTOR SWITCH**

This switch (3) is used to select between recirculation of the air inside the cab or intake of fresh air from outside.

When the switch is pressed, indicator lamp (A) at the top of the switch lights up.

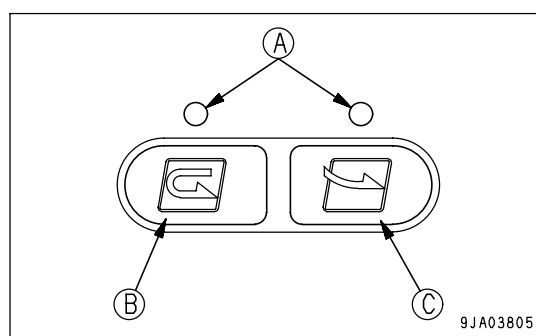
**Recirculation of air inside cab**

Press this switch (B) to use only the air inside the cab. Use this position to carry out rapid heating or cooling of the cab or when the outside air is dirty.

Intake of fresh air from outside

Press this switch (C) to carry out heating or cooling with fresh air taken in from the outside. Use this position when fresh air is taken in from outside the cab, or when removing the mist from the cab windows.

REMARK

When fresh air is taken into the cab, air pressure in the cab increases, which prevents the dust from entering. When neither heating nor cooling is needed, bring in clean fresh air, with your preferred air flow, to prevent dust from entering the cab.

TEMPERATURE CONTROL SWITCH

This switch (4) can be used to adjust the temperature steplessly between low temperature and high temperature.

The temperature level indicator lamps (A) light up to display the temperature of the air coming from the vents.

The more blue lamps on, the lower the temperature is.

The color of the indicator lamp (A) changes while the switch is being pressed.

When the temperature reaches the desired level, release the switch to set the temperature.

The settings for each mode are retained in memory even when the starting switch is turned OFF.

However, in the following cases, the settings must be reset.

- When the machine has been out of use for more than 7 days
- When the battery voltage is extremely low
- When there has been abnormal interference from outside
- When the fan switch is turned OFF (the setting is not kept in memory with only the air conditioner switch)

If the air conditioner is used in the FRESH position, the inside of the cab will be pressurized and this will prevent the entry of dust.

The higher the position of the fan switch, the more effective the pressurizing becomes.

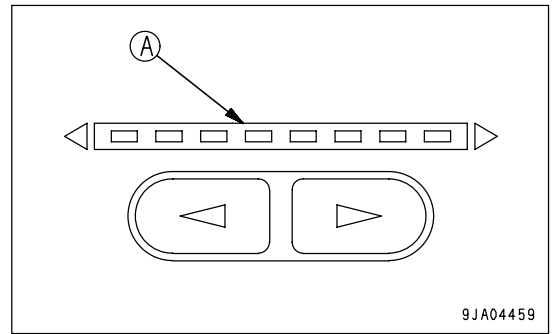

METHOD OF OPERATION

Switch		Fan switch	Air conditioner switch	Temperature control switch	FRESH/RECIRC selector switch
Condition of use	Rapid	HI	ON	All blue	RECIRC
	Normal	HI - LO	ON	More than half are blue	FRESH
Dehumidifying, heating		HI - LO	ON	More than half are red	FRESH
Heating	Rapid	HI	OFF	All red	RECIRC
	Normal	HI - LO	OFF	More than half are red	FRESH
Defroster		HI	ON	More than half are red	FRESH
Ventilation or pressurizing		HI - LO	OFF	All blue	FRESH

When defrosting, set the temperature control switch so that all lamps are red. This will improve defrosting and demisting.

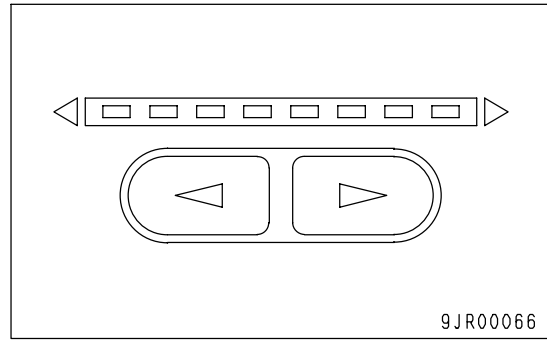

WHEN NOT USING THE AIR CONDITIONER REGULARLY

Run the air conditioner in cooling or dehumidification + heating mode for several minutes from time to time to prevent the loss of the oil film in various parts of the compressor.

REMARK

If the temperature inside the cab is low, the air conditioner may not work. In such cases, use the recirculated air to warm up the inside of the cab, then turn the air conditioner switch on. The air conditioner will be run.

COOL BOX

When the cooling is being used, this can be used for keeping drinks and other things cool.

When the heating is being used, it can be used to keep things warm.

When not using the box, close the grill.

Do not use the cool box for things which smell or leak water or break easily.

Do not use it as a holder for tools or other small objects.

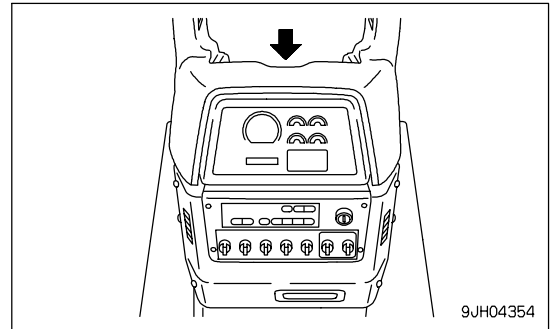
**PRECAUTIONS WHEN USING****PRECAUTIONS WHEN USING THE COOLING**

- If you smoke when using the air conditioner in the RECIRC mode, your eyes may start to itch or burn. Ventilate the cab ever so often to remove the smoke.
 - When using the air conditioner for a long period of time, carry out ventilation process at least once every hour.
- When using the air conditioner, it is recommended for health reasons, that it should only feel slightly cooler (5 or 6 °C (9 or 10.8°F) lower than the outside temperature) when you enter the cab. Therefore, adjust the temperature to a suitable level.

SET SO THAT COLD AIR DOES NOT DIRECTLY BLOW ONTO THE GLASS SURFACE

- If the vents (left and right) in the middle of the dashboard are turned so that cold air blows directly on the cab door glass, moisture may condense on the outside of the cab door glass and reduce the visibility. (This occurs particularly in high temperatures.)
If this happens, close the louvers of the vent and change the direction to prevent the cold air from blowing directly on the surface of the glass.

CHECKS DURING OFF-SEASON

Even during the off-season, run the compressor at low speed for several minutes once a week to prevent the loss of the oil film on the lubricated parts of the compressor.

(Run the engine at low speed and set to a mid-range temperature when carrying out this operation.)

REMARK

When the ambient temperature is low, if the compressor is suddenly run at high speed, it may cause failure of the compressor. Note that the system is set so that the compressor will not run when the cooler switch is turned on, if the ambient temperature is less than 2 to 6.5°C (35.6 to 43.7°F).

PROCEDURE FOR REPLACING RECEIVER

Replace the receiver once every 2 years.

After replacing the receiver, add compressor oil. Turn the receiver at an angle and measure the oil remaining inside the receiver, then add the same amount of oil (Denso Oil 6) to fill the receiver.

REMARK

- The replacement interval may become shorter depending on the conditions during use.
- If the receiver is used when the moisture absorption limit of the desiccant has been exceeded, the refrigerant circuit may become blocked and cause the compressor to break down.

PRECAUTIONS WHEN REPLACING RECEIVER

- If the receiver is left for more than 15 minutes with the blind cover removed, the moisture in the air will be absorbed, and this will reduce the life of the desiccant. If you remove the blind cover, connect the piping quickly, evacuate the system and fill with refrigerant.
- When removing the refrigerant from the refrigerant circuit, release it gradually from the low pressure side to prevent oil from flowing out.

CHECK COMPRESSOR BELT TENSION AND REFRIGERANT (GAS) LEVEL

If the compressor belt is loose, or the refrigerant level is low, cooling is not carried out efficiently.

For details, see "WHEN REQUIRED (PAGE 4-20)".

CLEANING AIR FILTER

If the air filter for the FRESH or RECIRC air intake becomes clogged, the cooling or heating capacity will drop.

To prevent this, clean the air filter with compressed air once a week.

For details of the cleaning method, see "WHEN REQUIRED (PAGE 4-20)".

HEATER, HANDLING

(Machine equipped with cab) (If equipped)

METHOD OF OPERATION

Switch Condition of use	Fan switch	Humidity control switch	RECIRC/FRESH selector switch
Rapid heating	HI	All red	RECIRC
Ventilation or pressurization	HI - LO	All blue	FRESH

TO HEAT QUICKLY

If the switch is operated as follows, the cab can be heated quickly.

- Set fan switch (1) to H1, humidity control switch (2) to All red, and RECIRC/FRESH selector switch (3) to RECIRC.
- Set blower switch (2) to position 3 (HIGH).

NOTICE

If the heating is run continuously for a long time using only recirculated internal air, the air in the cab will become dirty. After the cab warms up, always turn RECIRC/FRESH selector switch (3) to the FRESH position. In this position, the inside of the cab is pressurized, and this prevents the entry of dust.

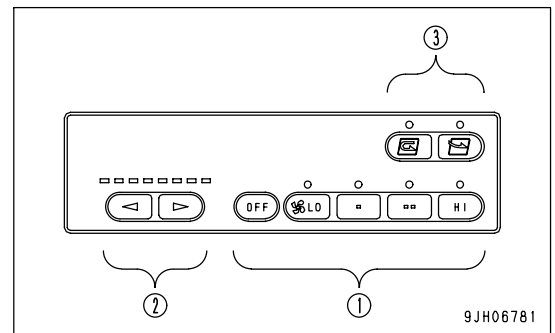

NORMAL USE

Set each switch to the desired position.

CLEANING AIR FILTER

If the RECIRC or FRESH air filters are clogged, the heating capacity will drop.

Clean the air filter once a week with compressed air.

For details of the method of cleaning, see "WHEN REQUIRED (PAGE 4-20)".

CAR STEREO, HANDLING

(Machine equipped with cab) (If equipped)

EXPLANATION OF COMPONENTS

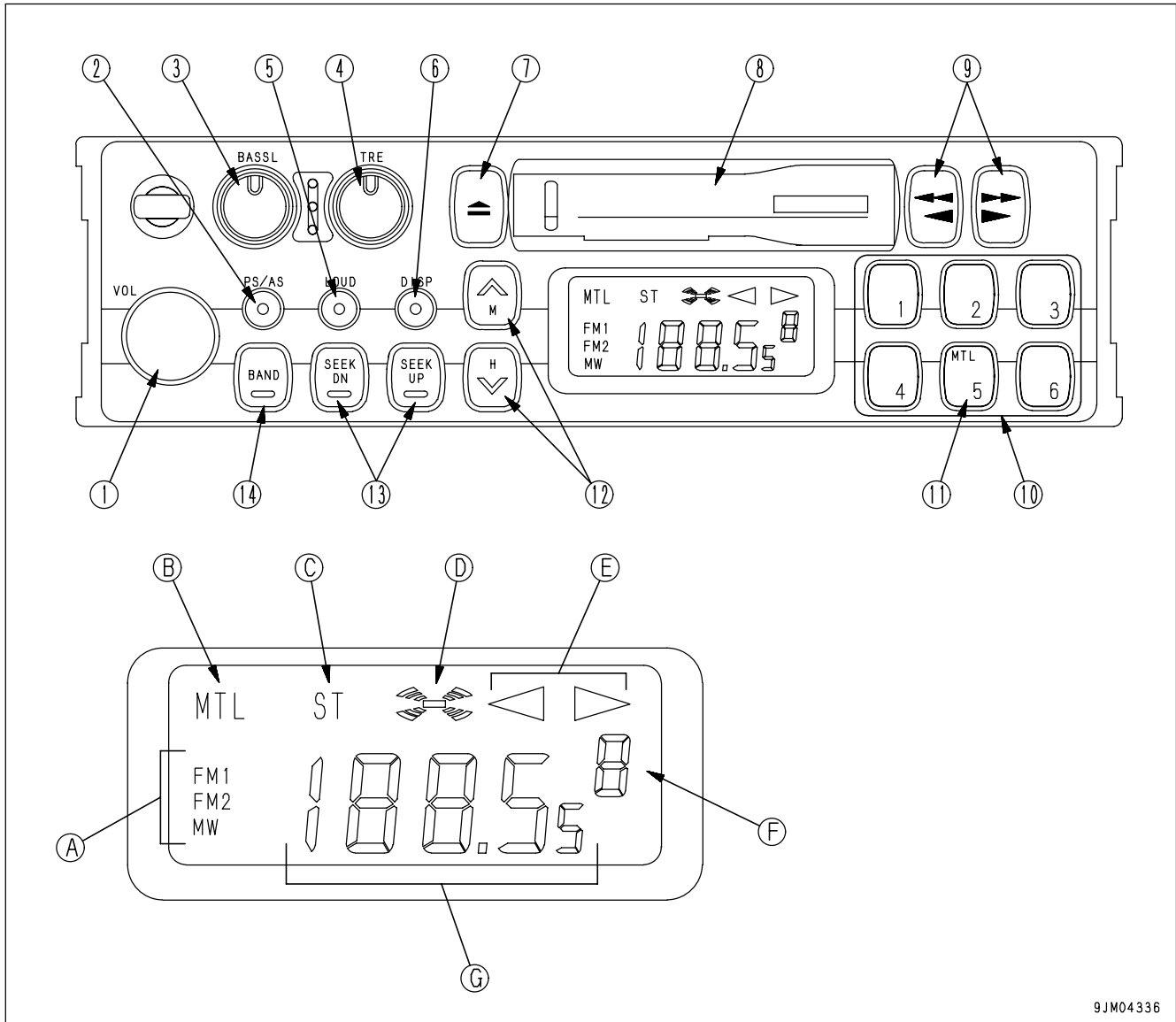

9JM04336

- | | |
|----------------------------------------|----------------------------------|
| (1) Power switch/volume | (8) Cassette door |
| (2) Auto-store/preset scan button | (9) Fast forward, rewind buttons |
| (3) Bass control knob | (10) Preset buttons |
| (4) Treble control knob | (11) Metal tape button |
| (5) Loudness button | (12) Manual tuning buttons |
| (6) Time/radio display selector button | (13) Seek tuning buttons |
| (7) Tape eject button | (14) Band selector button |
| (A) Band display | (E) Tape direction display |
| (B) Metal tape display | (F) Preset channel display |
| (C) FM stereo reception display | (G) Time/frequency display |
| (D) Loudness display | |

POWER SWITCH/VOLUME

Turn this knob (1) to the right until it clicks to turn the power on.
Turn it further to increase the volume.

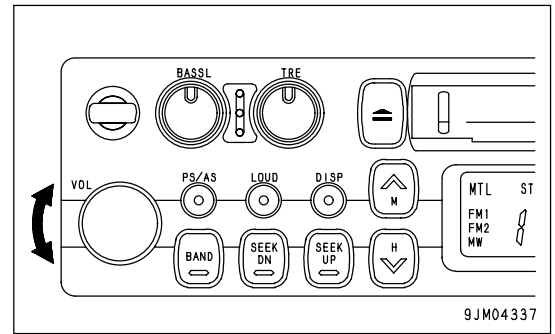

AUTO-STORE/PRESET SCAN BUTTON

Use this button (2) to actuate the preset scan and auto-store functions.

- Auto-store
Each time this button is pressed for more than 2 seconds while in radio reception, this auto-store function automatically starts to search for the desired station within a receivable band, and memorize the frequency in the preset memory. During this scanning process, the frequency shown in the right side of display continues to change. This indicates that each frequency is memorized in the auto-store.

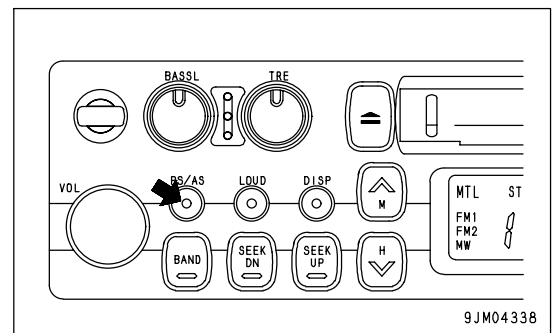

REMARK

The auto-store function cannot be used when the channel display is flashing.

When the display is flashing, the preset scan function is being used.

- Preset scan
If this button is pressed for less than 0.5 second while in radio reception, programs from the six preset stations in the same band will be broadcast one after another for 5 seconds each, starting from No. 1 through No. 6 stations consecutively.
When the desired station is found, press the button again. This stops the preset scan tuning process and switches to ordinary broadcasting. The same process will be repeated continuously until the button is pressed again.

BASS CONTROL KNOB

Turn this button (3) to the left to reduce the low tones; turn it to the right to emphasize the low tones.

- Direction (a): Low tone reduced
- Direction (b): Low tone emphasized

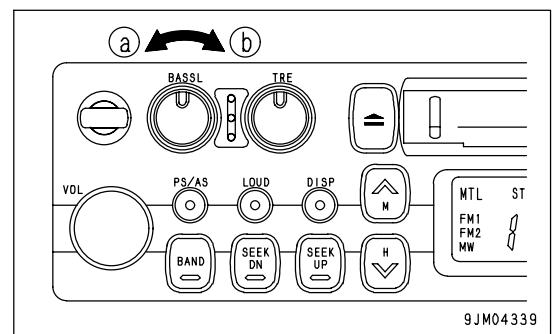

TREBLE CONTROL KNOB

Turn this button (4) to the left to reduce the low tones; turn it to the right to emphasize the high tones.

Direction (a): High tone reduced

Direction (b): High tone emphasized

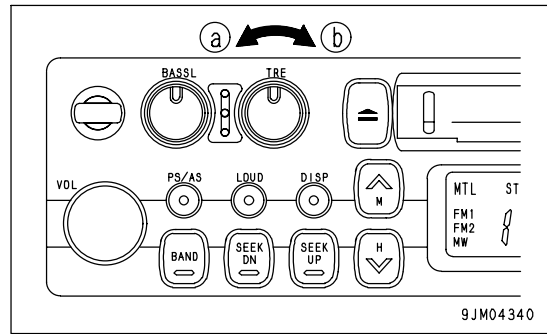

LOUDNESS BUTTON

This button (5) is used when playing at low volume. It makes it possible to hear more easily by emphasizing the low tone when the low tones are weak.

Push button: Actuated (ON)

Push button again: Canceled (OFF)

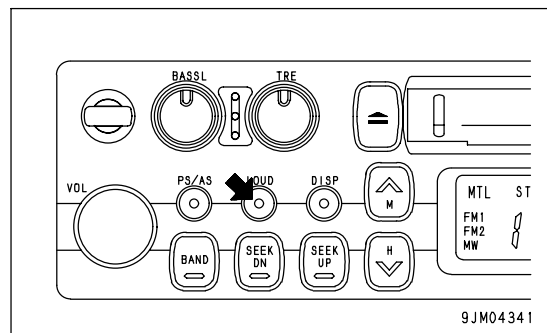

TIME/RADIO DISPLAY SELECTOR BUTTON

This button (6) is used to switch between the "Radio/tape display" and the "Time display".

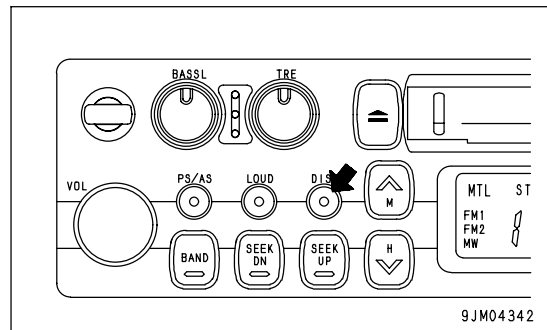

- Correcting the time

Press the button to set the time display.

(A) Correcting hour:

Keep the DISP button pressed and press the bottom (H) of the TUNING button to correct the hour.

(B) Correcting minute:

Keep the DISP button pressed and press the top (M) of the TUNING button to correct the minute.

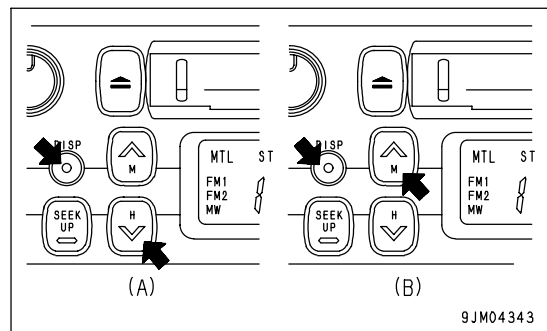

TAPE EJECT BUTTON

This button (7) is used to stop the tape and to eject the cassette. When this button is pressed, the tape is ejected and the radio plays.

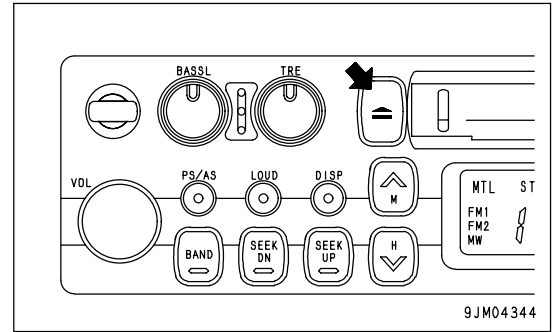

CASSETTE DOOR

Set the cassette with the exposed portion of the tape on the right side and insert it through the cassette door (8).

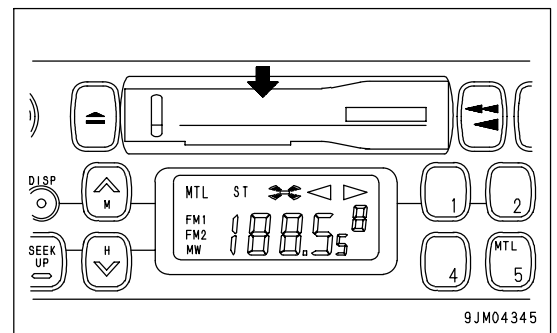

FAST FORWARD, REWIND BUTTONS

These buttons (9) are used to fast-forward or rewind the tape.

- Fast-forward/rewind

If you press the button pointing in the same direction as the lighted arrow indicating the direction of play, the tape will be fast-forwarded; if you press the button pointing in the opposite direction, the tape will rewind.

To stop the tape, lightly press the button that is not locked. The fast-forward or rewind operation will be canceled.

If the fast-forward and rewind buttons are pressed at the same time, the tape will change sides.

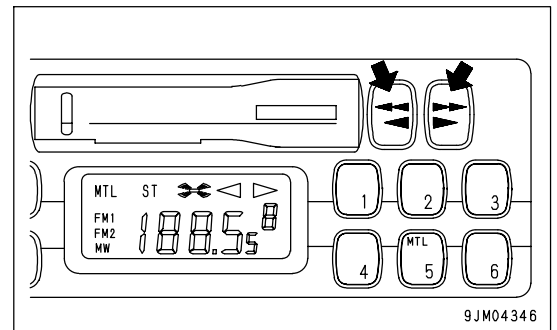

PRESET BUTTONS

These buttons (10) are used to call up the broadcast station frequencies preset in memory for each of buttons No. 1 to No. 6. It is possible to preset 18 stations (FM: 12; AM: 6) with these buttons.

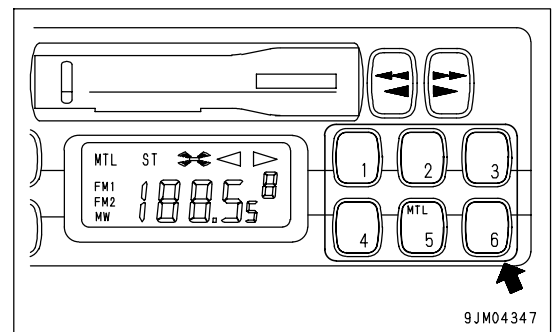

METAL TAPE BUTTON

(used also for preset button No. 5)

This button (11) is used when playing a metal or chrome tape. This button is also used for preset button No. 5. When it is pressed, "MTL" appears on the display.

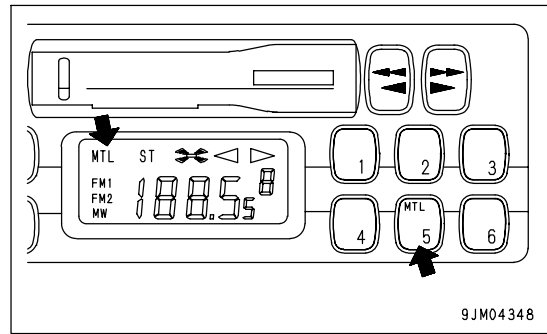

MANUAL TUNING BUTTONS

These buttons (12) are used for manual tuning.

When "TUN ^" button is pressed, the frequency goes up; when "TUN v" button is pressed, the frequency goes down. If the button is pressed down and held, the frequency will change continuously.

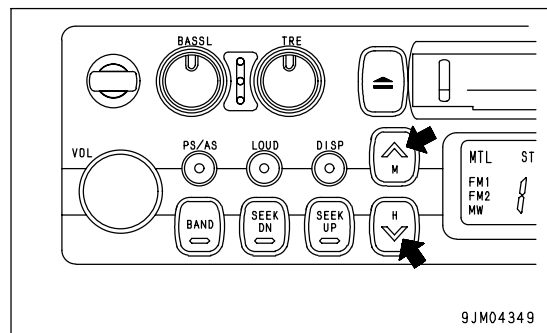

SEEK TUNING BUTTONS

These buttons (13) are used to seek tuning.

When the "SEEK UP" button is pressed, the search automatically goes up; when the "SEEK DN" button is pressed, the search automatically goes down.

When the next station that can be received is found, it automatically stops.

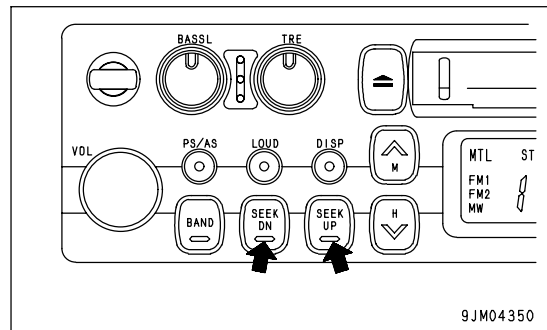

BAND SELECTOR BUTTON

When this button (14) is pressed, the band is switched between FM1, FM2, and MW (AM). The band is shown on the display.

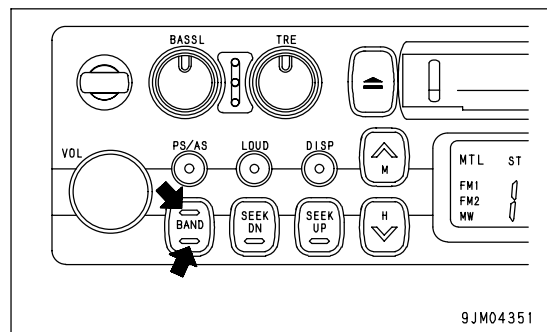

METHOD OF OPERATION

METHOD OF SETTING PRESET BUTTONS

It is possible to preset 6 MW (AM) stations and 12 FM stations (FM1: 6 stations, FM2: 6 stations).

REMARK

If you are playing the cassette, press the tape eject button to stop the tape.

METHOD OF AUTO PRESET

1. Use band selector button (1) to select MW (AM), FM1 or FM2.
2. Press auto-store/preset scan button (2) for less than 0.5 second.
3. The preset scan tuning function automatically searches for the desired station within the same band and can memorize as many as 6 stations in the preset memory.

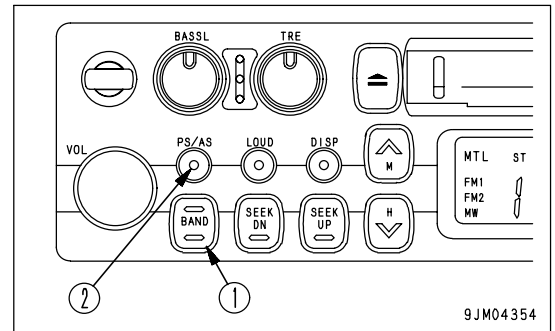

METHOD OF MANUAL PRESET

1. Use band selector button (1) to select MW (AM), FM1 or FM2.
2. Press manual tuning buttons (2) or seek tuning buttons (3).
3. Press preset button (4) of the number to be preset for 2 seconds while the frequency display is being shown on the display. (The preset channel and frequency are displayed and the presetting is completed).
4. Repeat the steps explained in Item 2 and 3 above to preset other stations to the subsequent numbers.
5. If you want to preset a station in the other bands, follow the steps explained in Item 1 through 4 above.

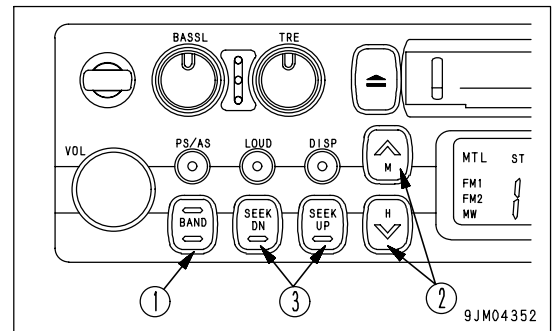

REMARK

- Also, use Steps 2 and 3 when changing the setting of a preset switch to another station.
- When the power is disconnected, such as when the battery is replaced, all the settings are deleted, so preset the stations again.

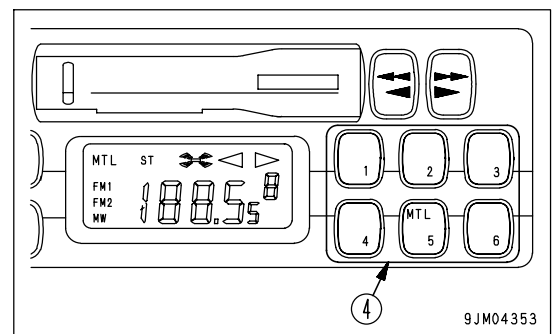

LISTENING TO RADIO

1. Turn the starting switch ON, then turn power switch (1) ON.
2. Use band selector button (2) to select MW (AM), FM1 or FM2.
3. Select the station with the preset buttons (3).

REMARK

In case you do not promptly remember the number assigned to a certain preset station, press auto-store/preset scan button (4) for less than 0.5 second. The preset 6 stations will broadcast one after another for 5 seconds each. When the desired station broadcasts, press the button again and scan tuning stops.

4. If you want to tune in to a station that is not preset, use either seek tuning button (5) or manual tuning button (6).
5. Adjust the volume, balance, and tone as desired.
6. When turning the radio OFF, turn power switch (1) to the left until it clicks.

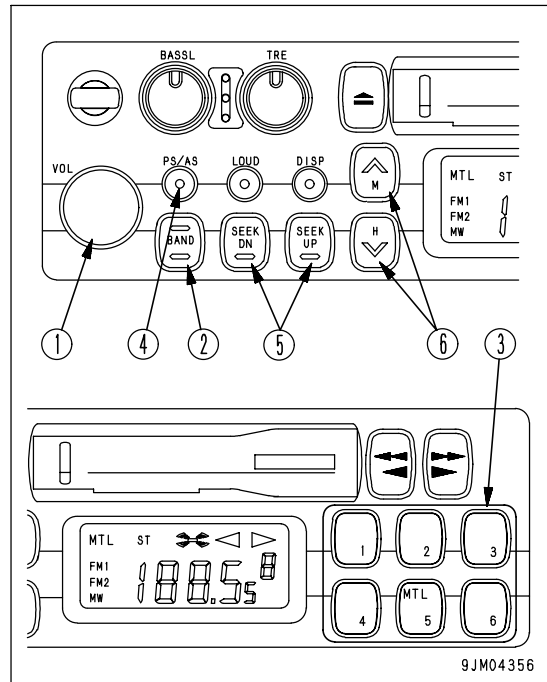

REMARK

- To switch to the radio when listening to a cassette, press the cassette eject button to stop the tape.
- If you insert a cassette when listening to the radio, the tape will start to play.

LISTENING TO CASSETTE TAPE

1. Turn the starting switch ON, then turn power switch (1) ON.
2. Set the cassette with the exposed portion of the tape on the right side and push it past the cassette door. The tape will automatically start playing.

If the arrow indicating the direction of play is pointing to the right, the top side is being played; if the arrow is pointing to the left, the bottom side is being played.

When the tape reaches the end, it is automatically reversed and the other side starts to play.

3. When finished with the tape, press the cassette eject button to eject the tape and automatically switch to the radio.

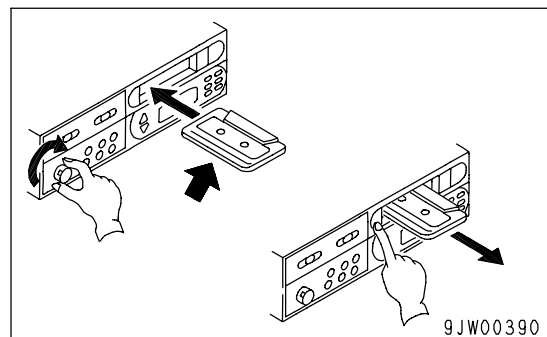
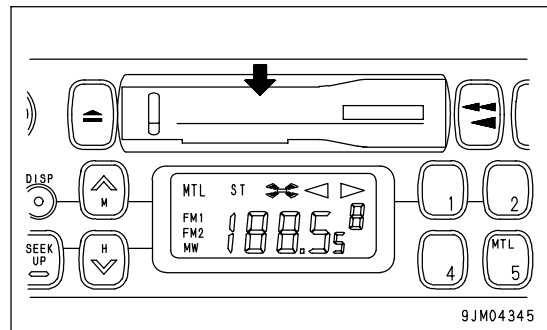

REVERSING TAPE

When listening to the tape, press both FAST FORWARD, REWIND buttons (A) and (B) at the same time lightly.

When this is done, the tape direction display will be reversed.

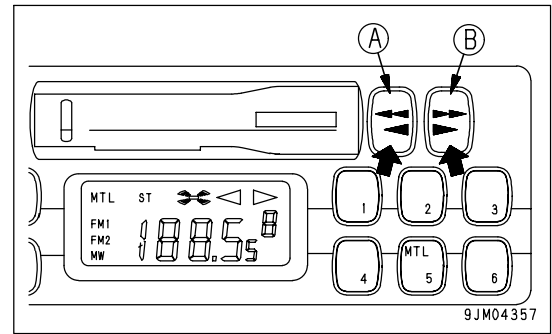
**PRECAUTION WHEN USING****WARNING**

- If a voltage greater than the specified voltage is input, it may cause fire, electrocution, or other failure. Never input any voltage other than the specified voltage.
- Places inside the radio are under high voltage. Do not remove the cover.
- Do not carry out any modifications. This may cause fire, electrocution, or other failure.
- If the sound cannot be heard, nothing is displayed, or any other problem occurs, turn off the power switch and ask your Komatsu distributor to make repairs without delay.

- Stow the antenna when traveling in places with low overhead clearance.
- To ensure safety during operations, keep the volume at a level where it is possible to hear other machines.
- If water gets inside the speaker case or radio (auto tuning), it may cause a serious problem, take care not to let water get in these items.
- Do not wipe the scales or buttons with solvent such as benzene or thinner. Wipe with a dry soft cloth. If the dirt cannot be removed easily, soak the cloth with alcohol.

NOTICE**Handling cassette tape**

- Clean the tape head approx. once a month with a commercially available head cleaning tape.
- Do not leave the tape any place where it is exposed to direct sunlight, any place that is excessively dusty, or any place where there is a magnetic field.
- Do not use 120-minute tapes. The tape is thin and it easily gets caught up inside the machine.
- If the tape is slack, it easily gets caught up inside the machine. Use a pencil to wind in the tape to remove any slack.
- Do not use any cassette tape if the label has started to come off. It may cause defective rotation, or it may be impossible to get the tape out of the machine.

EXTERNAL POWER SOURCE TYPE ENGINE PREHEATING HEATER

For cold weather (ambient temperature -30°C (-22°F))

This preheater is used as a starting aid when it is difficult to start the engine because of the cold temperature. It is used even when the ambient temperature is above -20°C (-4°F) in seasons where the temperature goes down to -20°C (-4°F).

Using an external power source (single phase, AC200 - 240V) to heat up the engine coolant and the oil in the engine oil pan and power train oil pan will make it easier to start the engine.

PROCEDURE FOR SETTING UP EXTERNAL POWER SOURCE

1. When using this engine preheating heater, it is necessary to provide the following external power source.
For details, see Step 3.
2. It is necessary to make locally the cable used to bring the electricity above to the input socket (receptacle) installed to the machine from the external power source.
For details of the manufacturing procedure, see Section 4.
3. The external power source input cable is the electric cable to bring the electricity from the local AC power supply to the input socket on the machine. Connect it as shown in the diagram below to operate the electric heater.

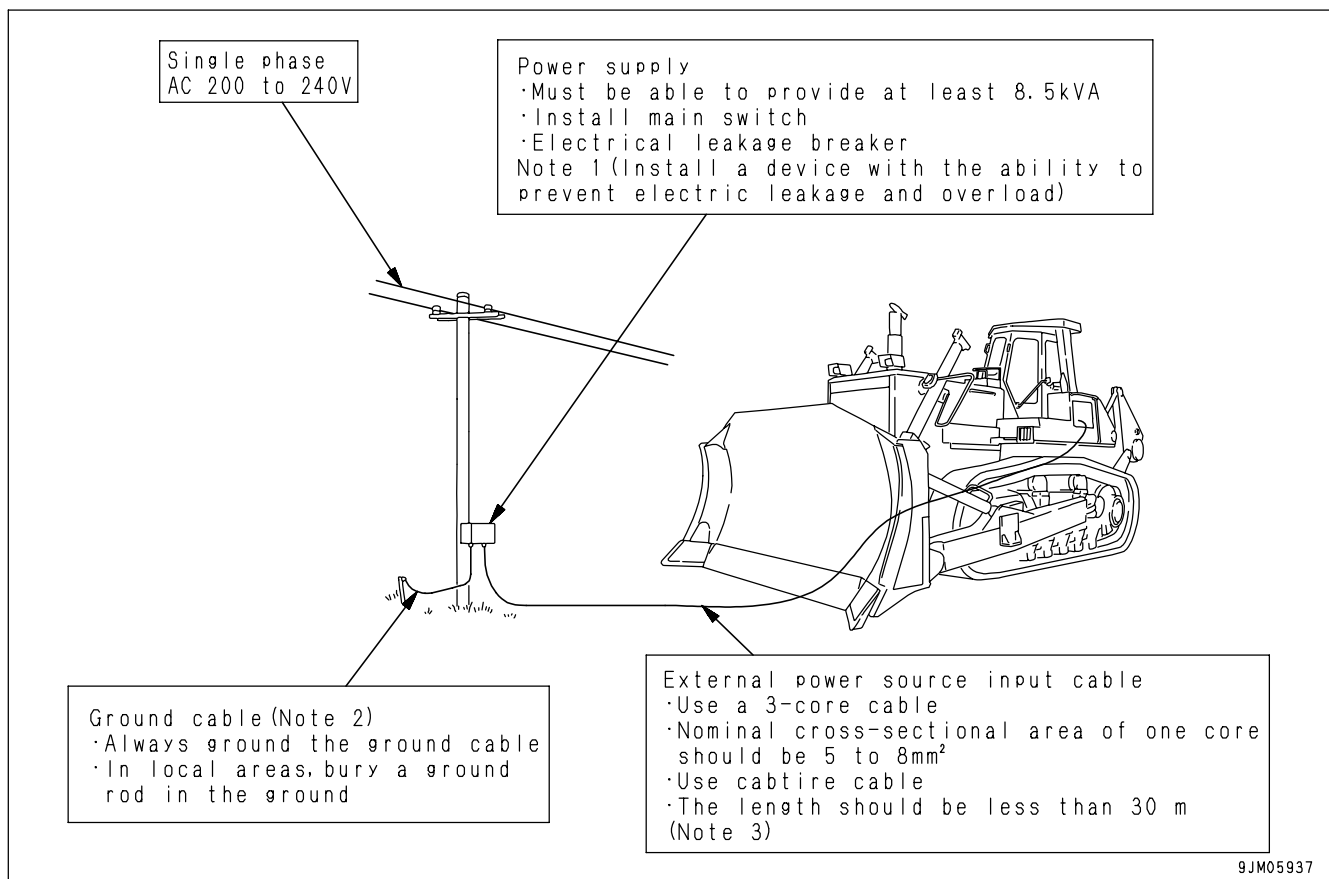

REMARK

- The electric leakage breaker is installed to prevent danger of electrocution if the electrical supply leaks to the machine.
- The ground cable is connected to the ground for the same reason.
- This is to prevent any drop in voltage.

4. Manufacturing external power source input cable

The external power source input cable must be manufactured locally to match the local conditions. This does not mean that any cable can be used.

Manufacture the cable as follows.

1) For the wiring, purchase three-core chloroprene sheath cab tire cable locally.

- The nominal cross-sectional area of one core should be 5 to 8 mm².
- For the voltage resistance function, it should be able to withstand 3000 volts for 1 minute.
- To prevent any drop in voltage, make the length less than 30 m (98 ft 5 in).

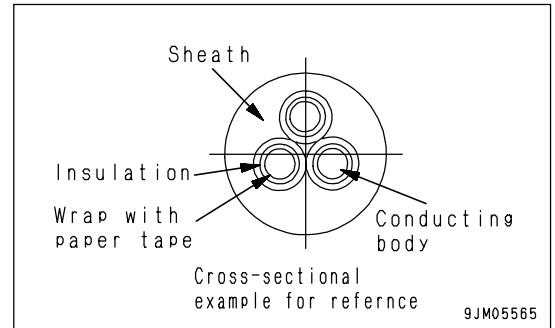

2) Connect the chassis input side plug (shipped as individual part) 175-06-37871 to the tip of the cable.

- The plug has three contacts and each contact is marked with a symbol. Connect each of the 3 core wires of the cable to its respective contact.
- When connecting, solder each core wire to its contact.
- To prevent short-circuiting through the conductor, insulate the soldered portion with a rubber tube or tape.
- Always use part No. 175-06-37871 for the plug.

If any other plug is used, it will be impossible to connect to the external power input receptacle.

Contact symbol	Core wire to connect
A	Ground circuit wire
B	Power source circuit wire
C	Power source circuit wire

9JM05566

- 3) Modify the other end of the cable so that it can be connected to the power supply equipment. When the modification of the connection is finished, the external power source input cable is completed.

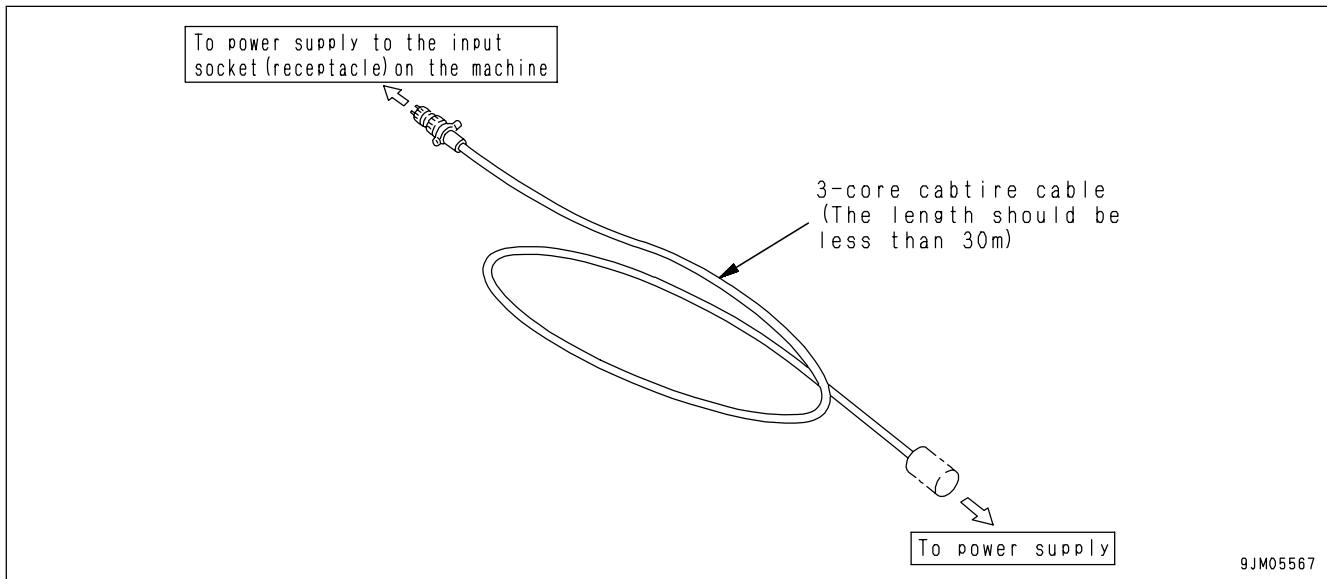

5. Establishing power supply



WARNING

When setting up the power supply equipment, follow all the related laws and regulations in that country and use an authorized contractor.

- 1) Power supply equipment is needed to use this preheater. The power supply equipment is used to supply AC voltage sent from the transformer substation or generator to the preheater. It must have a structure that enables the external power source input cable to be connected easily.
- 2) The shape, size, and method of setting up depend on the local area, but make the specifications as follows. Note that there is no switch or safety device provided on the machine.

- Specifications for power supply equipment
 - Type of output electricity: Single-phase alternating current
 - Output voltage: 200 - 240 volts (V)
 - Supply capacity: 8.5 kilovolt amperes (kVA)
 - Main switch: Yes
 - Electric leakage breaker: Yes
 - Ground circuit: Yes
- System diagram, overall wiring diagram (for reference when carrying out the work)
- System diagram for external power supply type engine preheater

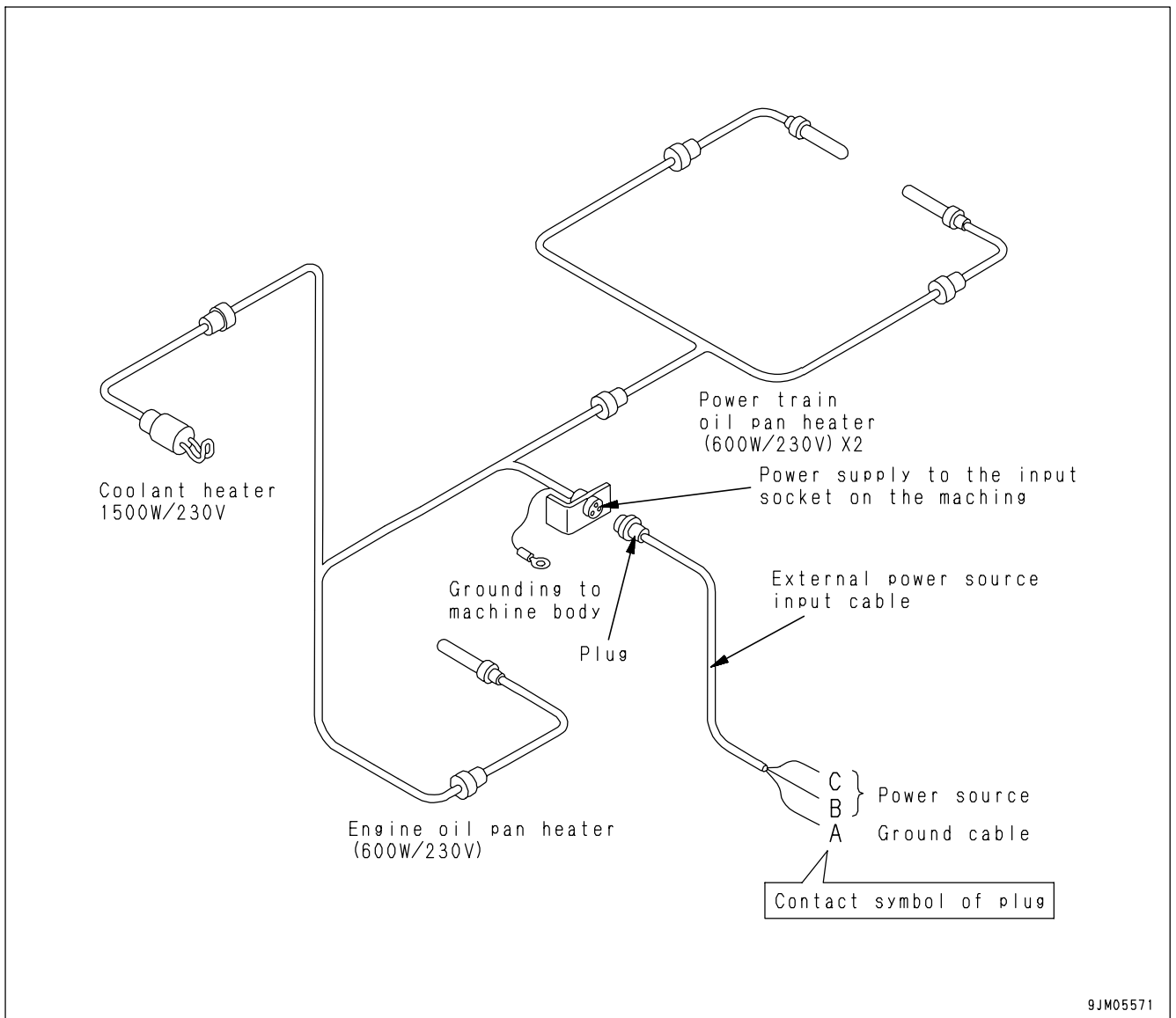

- Overall wiring diagram for external power supply type engine preheater

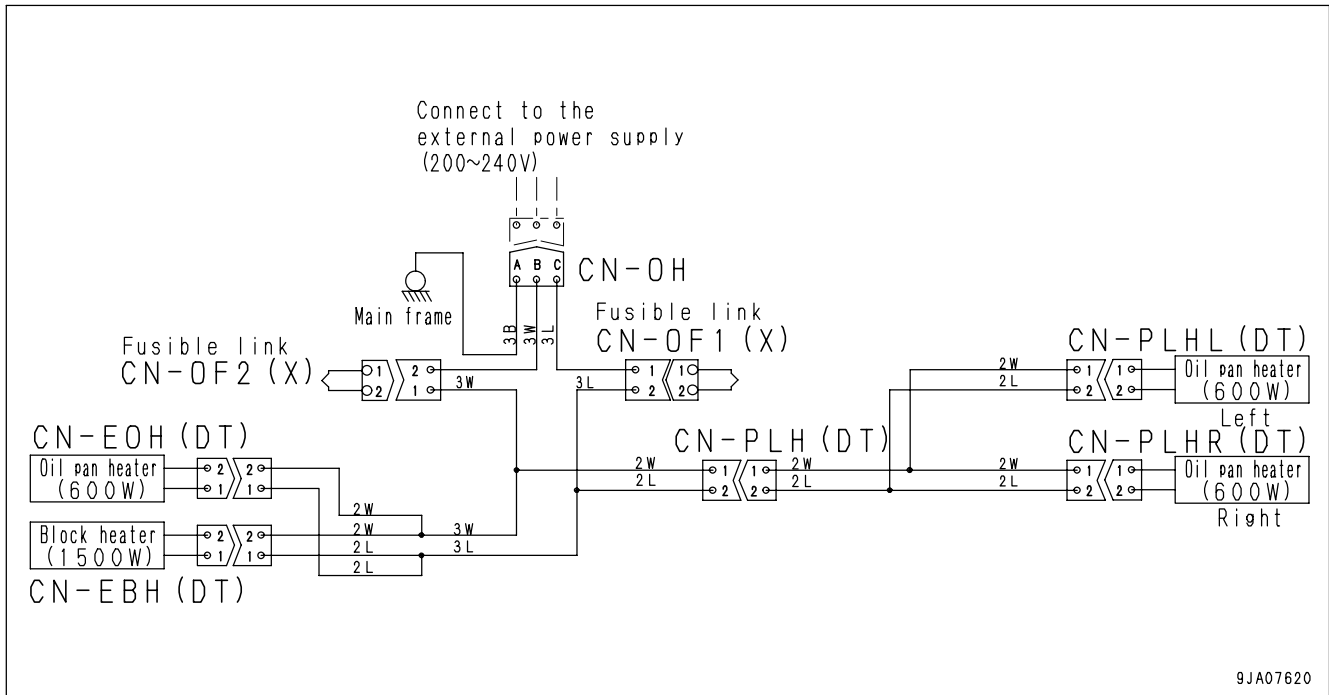

HANDLING PROCEDURE

Use this engine preheating heater in a season when the ambient temperature goes down below - 20°C (4°F), or when it is difficult to start the cold engine though the ambient temperature stays above - 20°C (4°F).

NOTICE

For details of the oil to use, see "RECOMMENDED FUEL, COOLANT, AND LUBRICANT (PAGE 4-10)".

Method of operating



WARNING

- Always lower the work equipment completely to the ground.
- Always wipe off any oil or fuel on the engine preheating heater or nearby parts.
- Always remove dry leaves or other flammable materials accumulated inside the engine room.
- Always check that the engine oil and engine coolant are at the specified level.
- Before passing electricity through the preheater, check that there is no damage to the covering of the wires. If any damage is found, replace or repair the wire.



WARNING

- Never connect the cables after the power switch has been turned ON. This is dangerous.
- Check that the grounding wiring is properly grounded before turning the power switch ON.

1. After completing operations with the machine, park the machine near the power supply facility (in a place where the external power input cable will reach the power supply). This will make it possible to use the preheater when starting the engine the next time.

NOTICE

- Park the machine on level ground.
- Take action to prevent the track shoes from freezing and sticking to the ground surface.
- Covering the machine will make it easier to start the engine.

2. Turn the power for the engine preheating heater on several hours before starting the engine to warm up the coolant and oil in the engine oil pan.

1) Connect the power supply to the input socket on the machine with a cable.

The input socket on the machine is inside the battery cover on the left side of the machine.

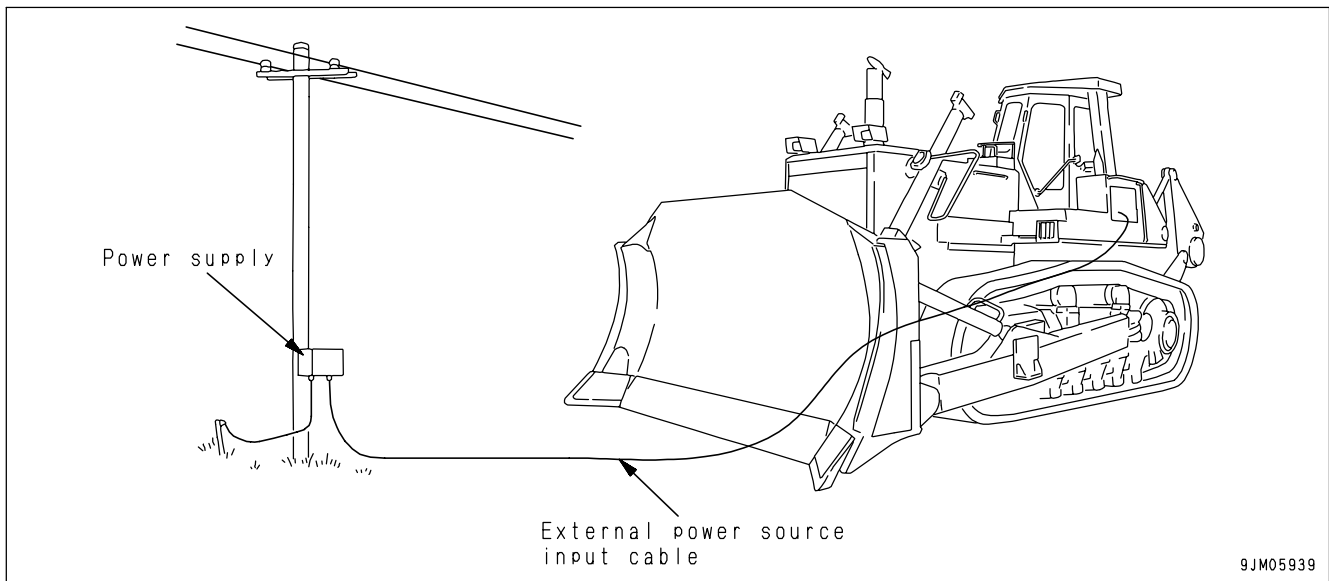
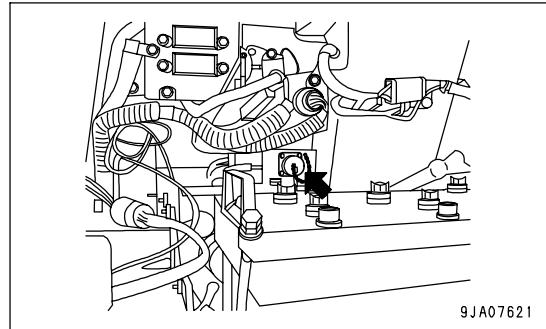

2) Use the standby switch (if available) or the power switch (main switch) on the power supply equipment to start the supply of electricity.

- Never connect the cables after the power switch has been turned ON. This is dangerous.
- Check that the grounding wiring is properly grounded before turning the power switch ON.

3. The time to keep the electricity on differs according to the ambient temperature and the type of oil being used.

Ambient temperature	Type of oil	Min. ON time for electricity
-30°C (-22°F)	SAE 10W	Min. 2 hours

- If the ambient temperature is below - 15°C (5°F), turn on the electricity immediately after stopping the engine on the previous day to maintain the engine temperature.
- The above table shows the standard values. If the weather conditions at the jobsite are unusual, it is effective to investigate the normal conditions that match the area, and use that as the standard.

NOTICE

- For details of the starting operation when the ambient temperature is below 0°C (32°F), see "STARTING IN COLD WEATHER (PAGE 3-97)".
- If the ambient temperature is above 0°C (32°F), do not pass electricity through the system. The oil temperature will rise and this will cause deterioration of the oil.
- If the ambient temperature is below - 20°C (- 4°F), and the engine has been stopped for more than two hours, use this engine preheating heater to maintain the temperature.

4. When the preheating operation is finished, turn off the power switch, disconnect the cable, and screw a protective cap in the input receptacle on the machine.
5. Start the engine.

NOTICE

Do not start the engine while the electricity is turned on. Always turn the power switch OFF before starting the engine. If the engine is started with the electricity still turned on, it will cause failure of the coolant heater.

OPERATION

CHECK BEFORE STARTING ENGINE, ADJUST

WALK-AROUND CHECK

Before starting the engine, walk around the machine and look at the underside of chassis for anything unusual like loose bolts and nuts, leakage of fuel, oil and coolant. Also check the condition of the work equipment and the hydraulic system.

Also check for loose wiring, play, and collection of dust at places that reach high temperature.



WARNING

- Leakage of oil or fuel, or accumulation of flammable material around high temperature parts, such as the engine muffler or turbocharger, may cause fire.
Check carefully, and if any abnormality is found, repair it or contact your Komatsu distributor.
- Do not get on or off the machine from the rear. Using this position is dangerous because it is easy to slip and you cannot be seen from the operator's compartment. Always use the handrail and step at the side when getting on or off the machine.

If the machine is at an angle, reposition it level before checking.

Perform the following inspections and cleaning every day before starting engine for the day's work.

1. Check for damage, wear, play in work equipment, cylinders, linkage, hoses
Check for cracks, excessive wear, play in work equipment, cylinders, linkage, and hoses. If any abnormality is found, repair it.
2. Remove dirt and debris from around the engine, battery, and radiator
Check for dirt accumulated around the engine or radiator. Also check for flammable material (dry leaves, twigs, grass, etc.) accumulated around the battery, engine muffler, turbocharger, or other high temperature engine parts. If any dirt or flammable materials are found, remove them.
3. Check for coolant and oil leakage around the engine
Check for oil leakage from the engine and coolant leaks from the cooling system. If any abnormality is found, repair it.
4. Check for leakage of oil from power train case, final drive case, hydraulic tank, hose, joints
Check that there is no oil leakage. If any abnormality is found, repair the place where the oil is leaking.
Check for leakage of oil from the undercover. Check the ground for traces of oil leakage.
5. Check the undercarriage (track, sprocket, idler, guard) for damage, wear, loose bolts, or leakage of oil from rollers
If any damage, wear, or oil leakage is found, repair the problem and tighten the bolts.
6. Check for damage to handrail and loose bolts
Repair any damage and tighten any loose bolts.
7. Check for damage to gauges, lamps on the instrument panel, and loose bolts
Check for damage to the panel, gauges, and lamps. Replace any damaged parts. Clean off any dirt on the surface.

8. Check for damage to seat belt and mounting clamps

Check that there is no abnormality in the seat belt or mounting clamps. If there is any damage, replace with new parts.

CHECK BEFORE STARTING

Always check the items in this section before starting the engine each day.

CHECK OIL LEVEL IN ENGINE OIL PAN, ADD OIL



WARNING

Parts and oil are at high temperature immediately after the engine is stopped and may cause serious burns. Wait for the oil temperature to go down before performing this operation.

1. Open the engine side cover on the left side of the chassis.
2. Remove dipstick (G), and wipe the oil off with a cloth.
3. Fully insert dipstick (G) into filler pipe (F), then remove it.

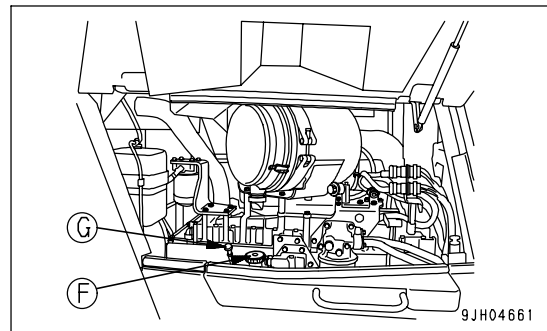

4. The oil level should be between the H and L marks on dipstick (G).
If the oil level is below the L mark, add engine oil through oil filler (F).

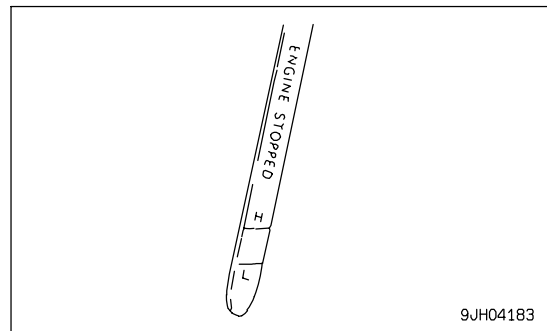

5. If the oil is above the H mark, drain the excess engine oil from drain plug (1), and check the oil level again.
6. If the oil level is correct, tighten the oil filler cap securely and close the engine side cover.

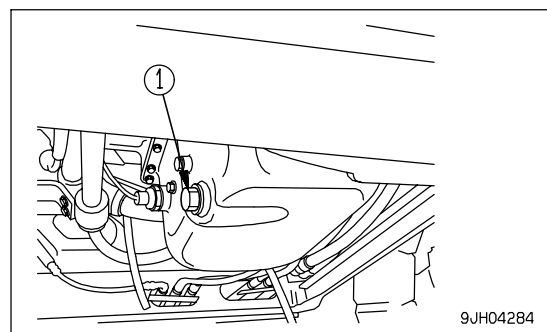

REMARK

- When checking the oil level after the engine has been operated, wait for at least 15 minutes after stopping the engine before checking.
- If the machine is at an angle make it horizontal before checking.
- When adding oil, remove the dipstick from the holder to release the air inside the crankcase.

CHECK COOLANT LEVEL, ADD COOLANT

**WARNING**

- Normally, do not open the radiator cap. When checking the coolant level, check the sub-tank when the engine is cold.
- Do not remove the cap when the radiator coolant is hot. Boiling coolant may spurt out. After the coolant temperature goes down, turn the cap slowly to release the pressure, then remove it.

1. Open the engine side cover on the left side of the chassis, and check that the coolant is between the FULL and LOW marks on sub-tank (1). If the coolant level is low, add coolant to the FULL level through the coolant filler port in sub-tank (1).

REMARK

The coolant may overflow from the sub-tank drain hose. This is no problem. It occurs because too much coolant has been added.

2. After adding coolant, tighten the cap securely.

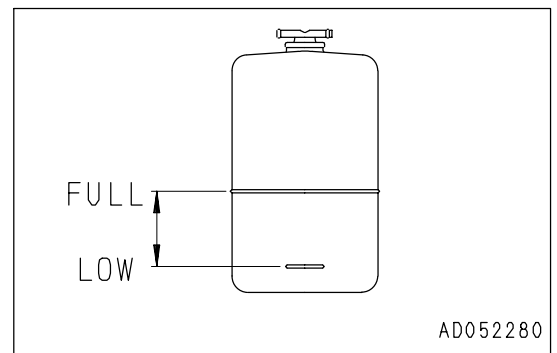
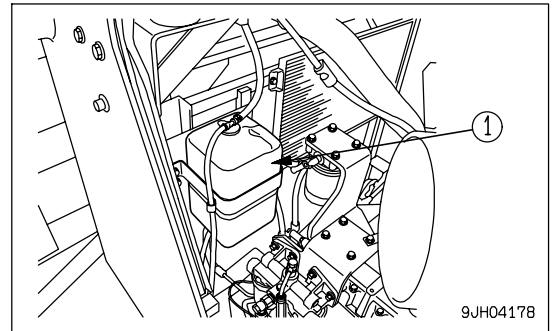

3. If the sub tank is empty, first check for leakage of water, then remove radiator cap (2) and check that the coolant water is above the bottom surface of the strainer as shown in the diagram on the right. Add water if the level is low.
4. After adding coolant, close the engine side cover.

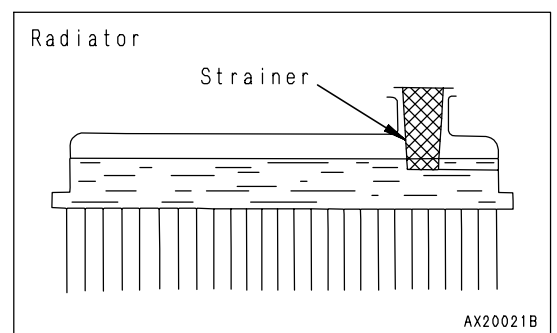
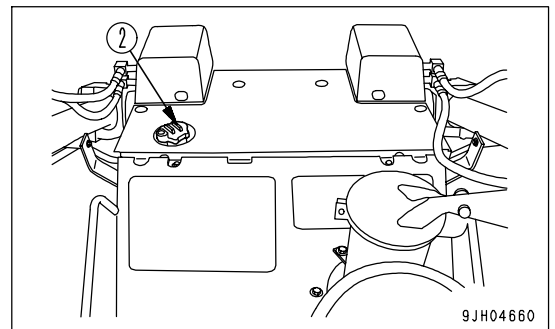

CHECK DUST INDICATOR

This is on the air cleaner bracket inside the engine room.

This device indicates that the air cleaner element is clogged.

For details on how to clean the element, see "CHECK, CLEAN AND REPLACE AIR CLEANER ELEMENT (PAGE 4-24)".

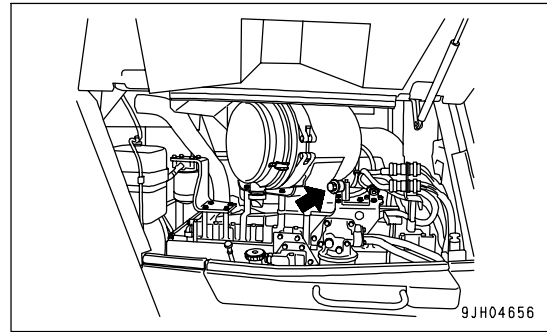

1. Check for the yellow piston overlapping the red zone on the dust indicator (1).
2. If the yellow piston is overlapping the red zone, clean or replace the element immediately.

For details of the method of cleaning the element, see "CHECK, CLEAN AND REPLACE AIR CLEANER ELEMENT (PAGE 4-24)".

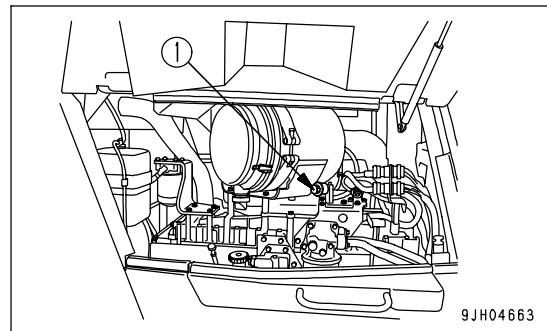

3. After checking, cleaning, and replacing, press the knob of dust indicator (1) to return the yellow piston to its original position.
 - In environments where the rubber deteriorates quickly or the surface becomes damaged (in direct sunlight, dusty areas, etc.), replace before it becomes dirty and it becomes difficult to judge the condition.

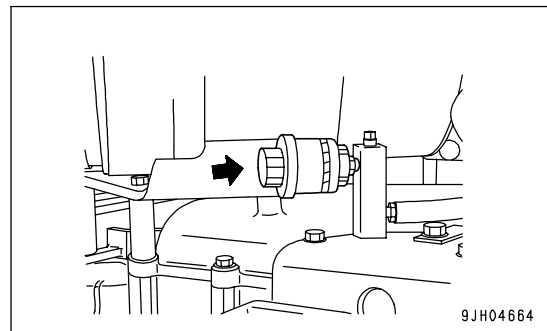

CHECK WATER SEPARATOR, DRAIN WATER AND SEDIMENT

1. Open the side cover on the left side of the machine.

The water separator and pre-fuel filter form one unit and are at the bottom.

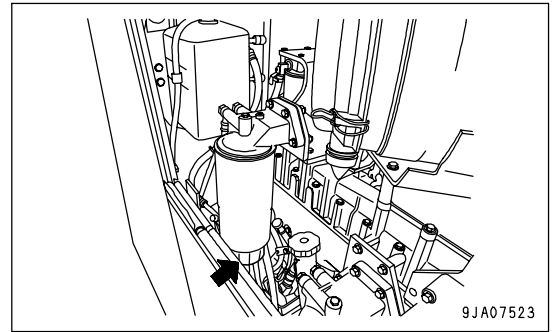

2. It is possible to judge the water level and amount of sediment by looking through transparent cap (2). If there is any water or sediment collected at the bottom, set a container to catch the drain water under drain hose (3).

3. Loosen plug (1) and drain the water.

4. When fuel comes out from drain hose (3), tighten plug (1) immediately.

Tightening torque: 0.2 to 0.45 Nm (0.02 to 0.046 kgm, 0.1 to 0.3 lbft)

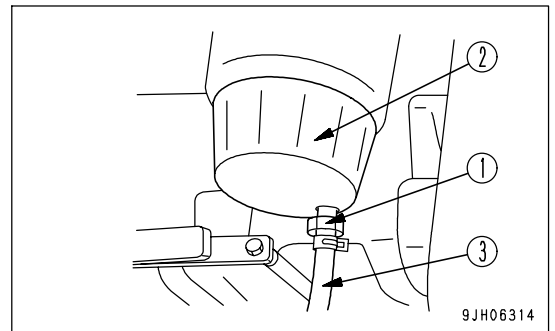

CHECK OIL LEVEL IN POWER TRAIN CASE, ADD OIL

**WARNING**

The parts and oil are at high temperature after the engine is stopped, and may cause serious burns. Wait for the temperature to go down before starting the operation.

1. Remove dipstick (G), and wipe the oil off with a cloth.
2. Fully insert dipstick (G) into filler pipe (F), then remove it.
3. Check that the oil level is between the top and bottom marks on dipstick (G).
If the oil level is below the bottom mark, add oil through the dipstick holder.

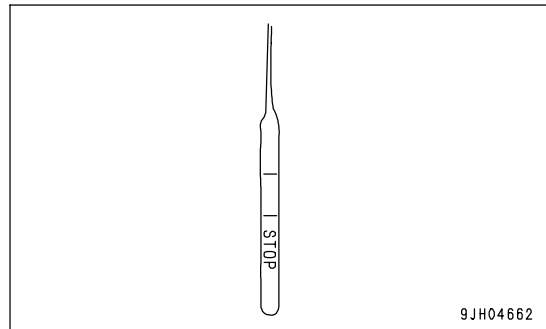
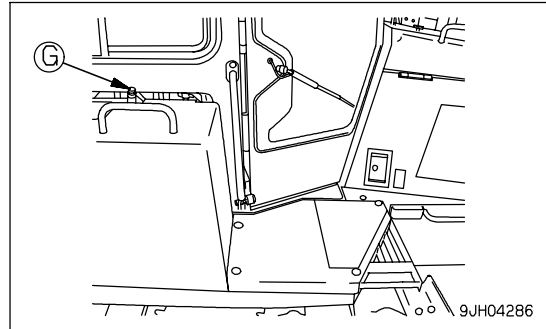

4. If the oil is above the top line, remove drain cover (1) at the right side at the bottom surface of the power train case, loosen drain plug (2), drain the excess oil, then check the oil level again.
5. If the oil level is correct, tighten the oil filter cap securely.

REMARK

- If the machine is at an angle, reposition it to level before checking.
- When checking the oil level after the engine has been operated, allow the engine to cool for 15 minutes before checking.

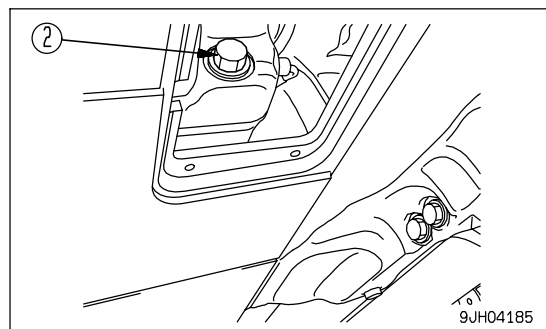
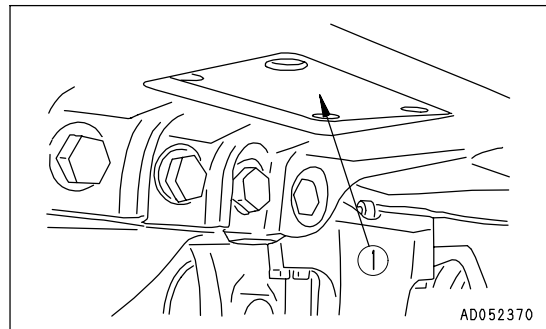

CHECK OIL LEVEL IN HYDRAULIC TANK, ADD OIL

WARNING

- When removing the oil filler cap, oil may spurt out, so stop the engine and wait for the oil temperature to go down, then push the cap down to release the internal pressure before removing the cap carefully.
- If oil has been added to above the H mark, stop the engine and wait for the hydraulic oil to cool down. Then remove drain plug (P), loosen drain valve (1), and drain the excess oil.

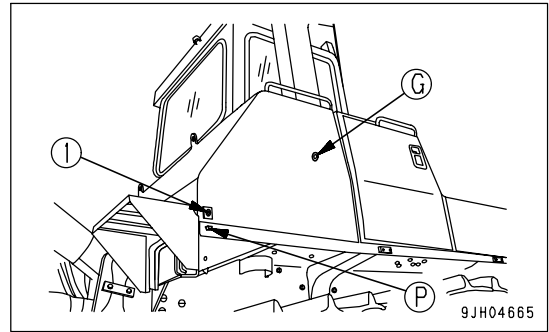

NOTICE

- Check the oil level when the oil is at low temperature. If the oil is at high temperature, the oil level will be higher.
- Do not add oil if the oil level is above the H line. This may damage the oil circuit and cause the oil to spurt out.

1. Lower blade to the ground and stop the engine. Wait for 5 minutes before checking oil level. Oil level should be between the H and L in sight gauge (G).

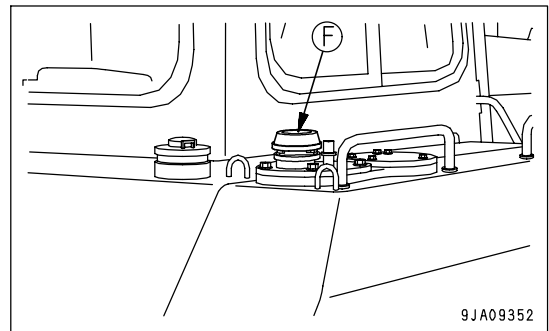

REMARK

When inspecting, if the machine is at an angle, move it to a level place to carry out the check.

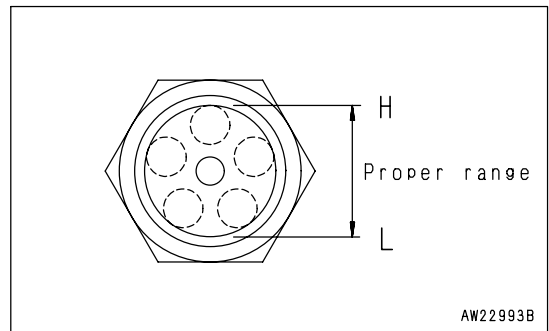

2. If the level is below the L mark, add oil through oil filler (F) as follows.

- 1) Push down cap of oil filler (F) to release the air and remove the internal pressure.
- 2) Keep cap pushed down, turn it slowly counterclockwise, then remove cap.
- 3) Refill the specified quantity of oil through oil filler (F).
- 4) Install cap.

When installing cap to the tank, push it down, then turn it clockwise.

REMARK

If the cap is not installed correctly, it will cause leakage of oil.

When installing the cap, press the cap down, and turn it until it is securely in contact with the stopper.

The cap is the lock addition type.

About handling method of cap with the lock, see "CAP WITH LOCK (PAGE 3-49)".

CHECK ELECTRIC WIRING



WARNING

- If fuses are frequently blown or if there is a short circuit in the electrical wiring, locate the cause and repair or contact your Komatsu distributor.
- Accumulation of flammable material (dead leaves, twigs, grass, etc.) around the battery may cause fire, so always check and remove such material.
- Keep the top surface of the battery clean and check the breather hole in the battery cap. If it is clogged with dirt or dust, wash the battery cap to clear the breather hole.

Check for damage and wrong capacity of the fuse and any sign of disconnection or short circuit in the electric wiring. Check also for loose terminals and tighten any loose parts.

Check the wiring of the "battery", "starting motor" and "alternator" carefully in particular.

Always check if there is any accumulation of flammable material around the battery, and remove such flammable material.

Please contact your Komatsu distributor for investigation and correction of the cause.

CHECK MACHINE MONITOR

1. Turn starting switch (1) to the ON position.
2. Check that the monitor and gauges light for 3 seconds, and the alarm buzzer sounds for 1 seconds.

REMARK

If the lamps do not light up, there may be a failure or disconnection in the monitor, please contact your Komatsu distributor.

NOTICE

Do not simply use the monitor to carry out the check before starting. Always carry out the check before starting according to the procedure on the following pages.

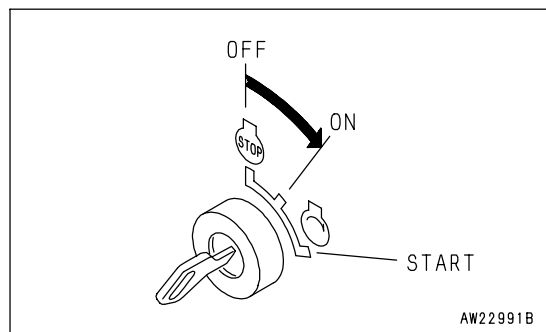
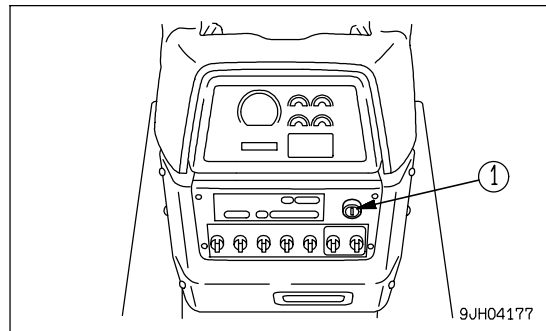

CHECK FUEL LEVEL, ADD FUEL

**WARNING**

When adding fuel, never let the fuel overflow. This may cause a fire. If the fuel is spilt, wipe it off completely.

1. Turn the starting switch to the ON position and check the fuel level with fuel gauge (G) on the monitor panel.
After checking, turn the switch back to the OFF position.

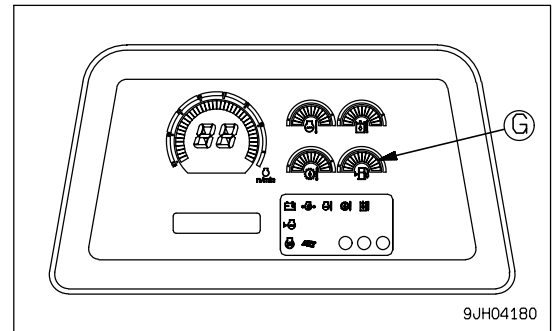

2. After completing work, fill the fuel tank through fuel filler port (F).
3. After adding fuel, tighten the cap securely.
Fuel capacity: 490 liters (129.46 US gal)

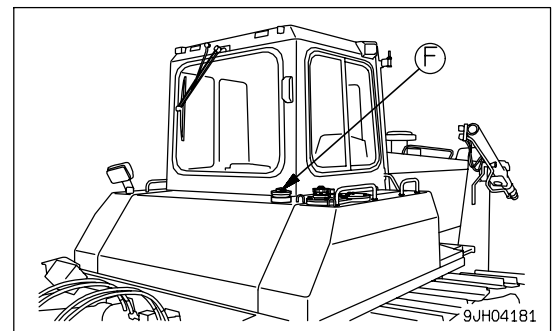
**REMARK**

- When dozing on a grade, make sure there is plenty of fuel in the tank so that the engine fuel line does not become aerated.
- If breather hole (1) on the cap is clogged, the pressure in the tank will drop and fuel will not flow.
Clean the hole from time to time.

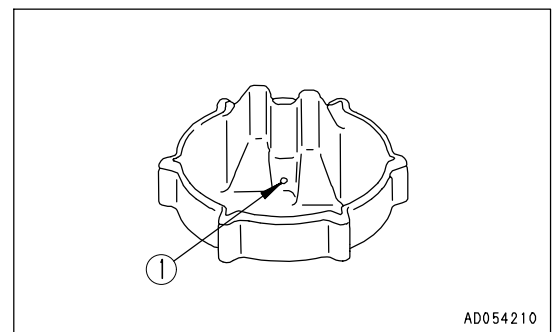

CHECK BRAKE PEDAL TRAVEL

**WARNING**

If the brake pedal stroke is not 69 to 79 mm (2.7 to 3.1 in) (below 69 mm or over 79 mm), the brake and steering force is too strong or insufficient. If the stroke is 80 mm (3.2 in) or longer, adjust it.

1. Depress the brake pedal all the way until it stops.
2. The distance of travel at the center of the pedal should be 69 to 79 mm (2.7 to 3.1 in).
3. When this value exceeds 80 mm (3.2 in), or the brake fails to work, please contact your Komatsu distributor for adjustment.

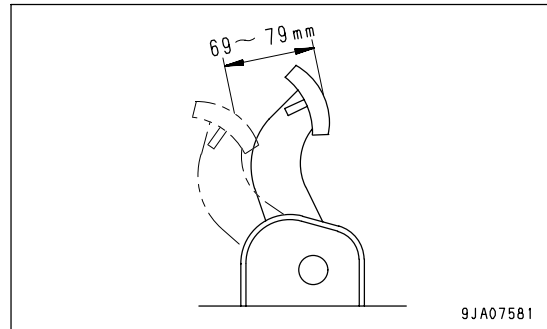

CHECK THAT LAMPS LIGHT UP

1. Turn starting switch key to the ON position.

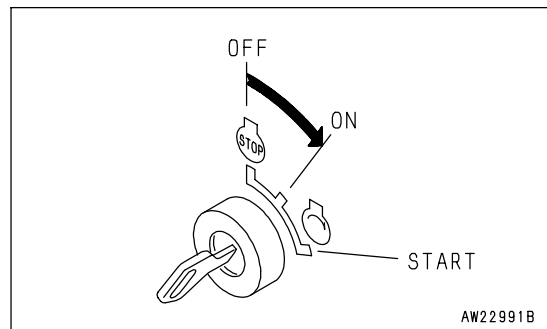

2. Turn the front lamp switch to the I (ON) position and check that the front lamp light up.

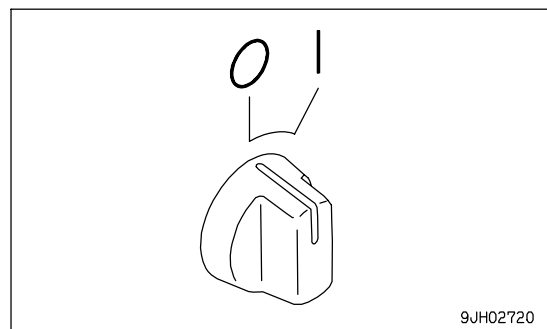

3. Turn the rear lamp switch to the I (ON) position and check that the rear lamps on the left and right fenders light up. If the lamps do not light, check for a broken bulb or disconnected wire, contact your Komatsu distributor for repairs.

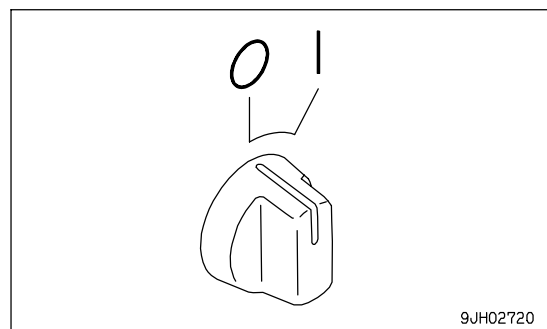

CHECK HORN SOUND

Check that the horn sounds. If it does not sound at all or the sound is extremely feeble, a defect or broken wire is suspected, ask your Komatsu distributor for possible repairs.

1. Turn starting switch key to the ON position.

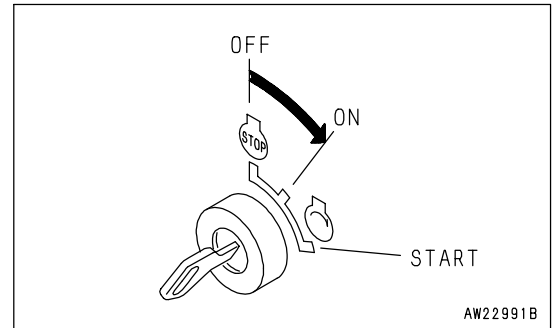

2. Push the horn switch and check that the horn sounds.

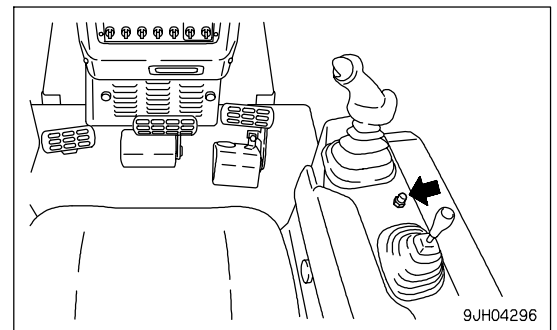

CHECK BACKUP ALARM SOUND

Check that the backup alarm sounds normally. If it does not, a defect or broken wire is suspected, ask your Komatsu distributor for possible repairs.

1. Turn the starting switch to the ON position.

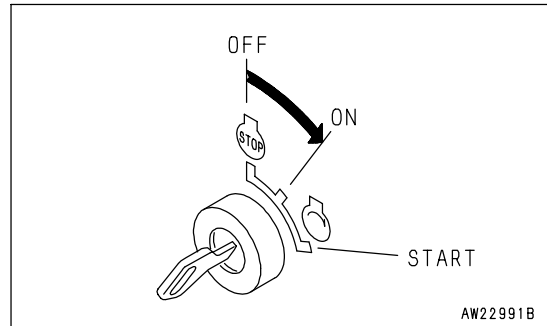

2. Set parking brake lever to the FREE position.

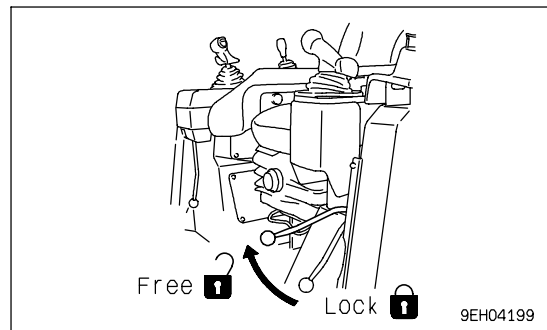

3. Set the steering, forward-reverse, gear shift lever in the REVERSE position.

The buzzer must sound immediately at this time. The buzzer keeps sounding until the steering, directional and gear shift lever is set to the NEUTRAL or FORWARD position.

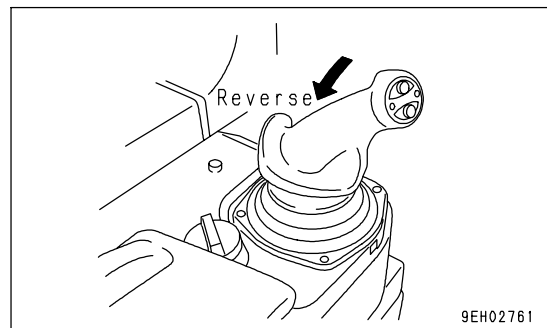

ADJUSTMENT

ADJUSTING OPERATOR'S SEAT



WARNING

When adjusting the position of the operator's seat, always set the lock lever to the LOCK position to prevent any accidental contact with the control levers.

- Always adjust the operator's seat before starting each operation or when the operators change shift.
- When adjusting the seat, put your back against the backrest and adjust to a position where the brake pedal can be fully depressed.

(A) Fore-and-aft adjustment

Pull lever (1), set the seat to a position where it is easy to operate, then release the lever.

Fore-aft adjustment: 160 mm (6.3 in) (8 stages)

(B) Weight and height adjustment of seat

- Turn knob (2) under the seat so that weight adjustment indicator (3) displays the green range. The height can be adjusted by turning the knob (2) while the green range is displayed.
- Turn the knob clockwise to raise the seat and turn the knob counterclockwise to lower the seat.

Height adjustment range: stepless, 75 mm (3 in)

Weight adjustment range: 50 to 130 kg (110 to 237 lb)

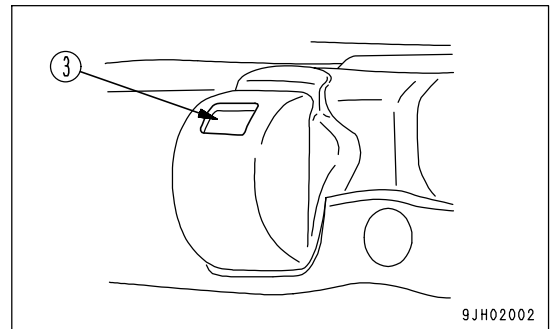
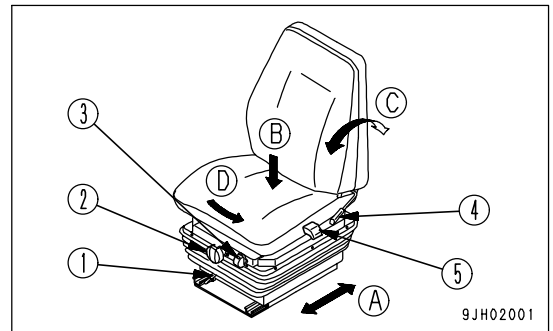

(C) Adjust reclining angle

REMARK

When the seat is pushed forward, the available reclining angle becomes greater; when the seat is pushed back, the available reclining angle becomes smaller. When moving the backrest, return the backrest to its original position before moving the seat.

Pull lever (4) up, set the backrest to the desired position, then release the lever.

(D) Adjusting direction of seat

Pull up lever (5) to unlock the seat. The seat can then be turned 15 ° to the right.

After changing the direction of the seat, return the lever securely to lock the seat.

- Change the direction of the seat to the right for the ease of operation of the ripper.

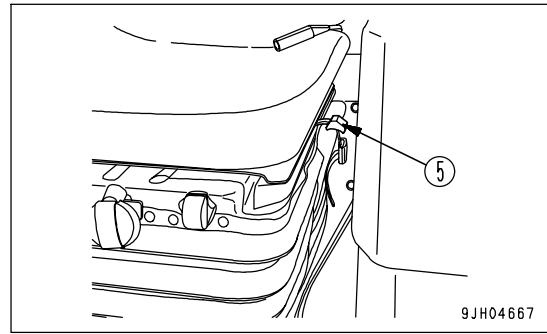

USING SEAT BELT

! WARNING

- Before fastening the seat belt, inspect the securing brackets and belt for abnormal conditions. Replace any worn or damaged seat belt or the securing brackets.
- Even no problem can be seen with the belt, always replace the seatbelt once every three years. The date of manufacture is given on the rear side of the belt.
- Adjust and fasten the seat belt before operating the machine.
- Always use the seat belt when operating the machine.
- Fit the seat belt across your lap without twisting.

Check that the bolts of the clamp securing the belt to the chassis are not loose. Tighten them if they are loose. The tightening torque for the mounting bolt is 24.5 ± 4.9 Nm (2.5 ± 0.5 kgm, 18.1 ± 3.6 lbf). If the belt surface is scratched or frayed or if the fittings are broken or deformed, replace the seat belt unit.

FASTEN THE BELT AND REMOVE IT

1. Sit on the seat, depress the brake pedal fully, and adjust the seat so that your back is pressed against the backrest.
2. After adjusting the seat position, adjust tether belt (1). Tense the tether belt and install it when there is no one sitting on the seat.
3. Sit on the seat and hold tongue (4) connected to wind-in mechanism (2) and pull out the belt slowly so that the belt will cover your abdomen sufficiently.
4. Insert tongue (4) in buckle (3) until it clicks. The belt is pulled back into wind-in mechanism (2) until it is fitted to your abdomen. The belt is locked under this condition and cannot be extended anymore. Fit the belt to your abdomen without twisting it.

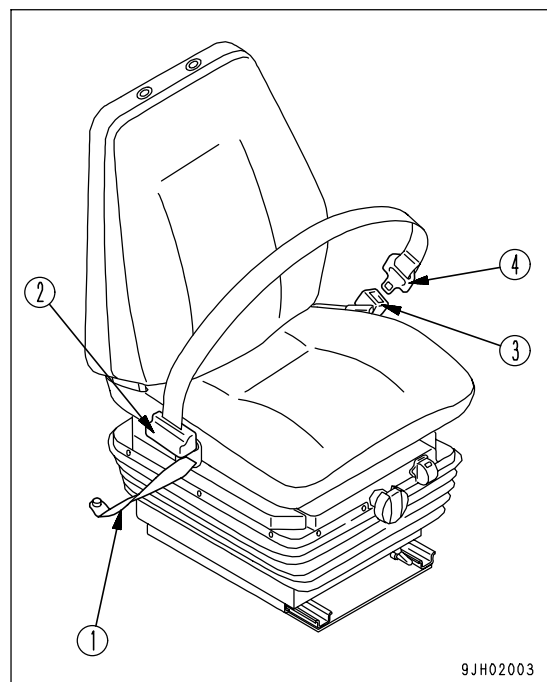

REMARK

If the belt is locked before the tongue is inserted in the buckle, let it return to the wind-in mechanism, then repeat the above procedure from the start.

5. Pull the belt to check that it is securely locked in position.
6. When removing the belt, press the red button on buckle (3). The belt will automatically retract.

ADJUST MIRROR

Loosen nut (1) of the mirror and adjust the mirror to a position where it gives the best view from the operator's seat.

In particular, be sure to adjust the mirror so that people at the rear left or right of the machine can be seen clearly.

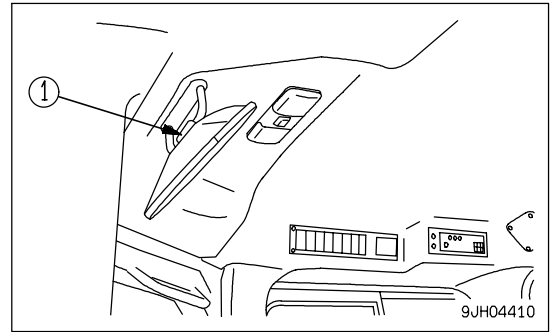
**ADJUST STEERING, FORWARD-REVERSE, GEAR SHIFT LEVER****WARNING**

After moving case (2) in order to adjust the position of the steering, directional, and gearshift lever, secure lock lever (1) into the notched hole, making sure it is in the LOCK position. If it is not completely locked, the steering, directional, and gearshift lever may unexpectedly move and cause damage, serious injury, or death.

The joystick can be adjusted by 90 mm (3.5 in) in 9 stages to the front or rear. Adjust to the most suitable position to match the adjustment of the operator's seat.

1. Pull up lock lever (1) to the FREE position at the rear of case (2) on left side of the operator's compartment.

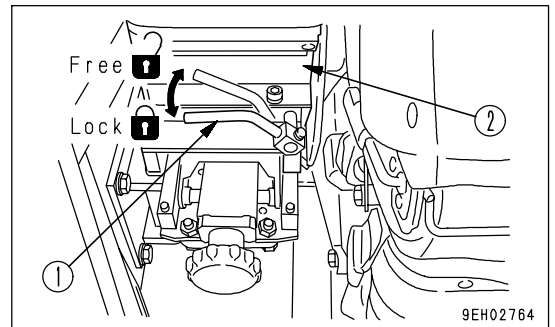
**NOTICE**

When moving case (2), do not grip the steering, forward-reverse, gear shift lever. There is danger that the lever may break.

2. With lock lever (1) pulled up, use your other hand to grip the front of case (2), then move it forward with your left and right hands. The joystick moves with case (2).
3. Move case (2) to the desired position until a click is heard. Then pull up lock lever (1) and release it. Lock lever (1) automatically returns to the LOCK position.

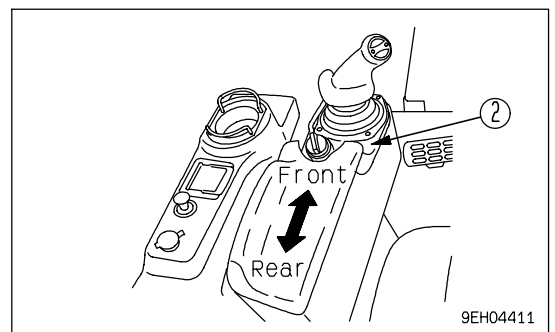

ADJUST ARMREST

The height of the armrest on the left and right sides of the operator's seat can be adjusted to 3 positions. After adjusting the operator's seat, adjust the armrest to a suitable height.

ADJUST ARMREST (RIGHT)

Armrest (1) on the right side of the operator's seat can be adjusted in 3 stages: up 30 mm (1.2 in), standard height (center), or down 25 mm (1.0 in).

1. Loosen knob (2) (2 places).

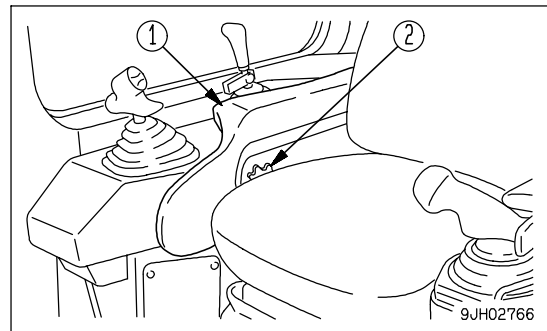

2. Move the armrest on the operator's seat to the front, then align the position of the 3 holes (high, middle, low).
3. Tighten knob (2) securely.

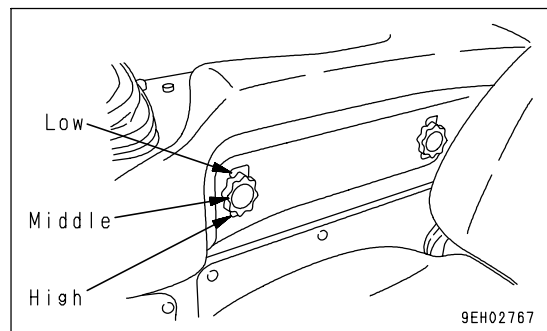
**ADJUST ARMREST (LEFT)**

The armrest on the left side of the operator's compartment can be adjusted to 2 heights.

It is possible to adjust the standard height up 30 mm (1.2 in) or down 30 mm (1.2 in) gradually.

The joystick moves as a unit.

Turn up/down left adjustment knob (1) to adjust the height. Turn the knob to adjust as follows.

Turn **CLOCKWISE** to move **DOWN**

Turn **COUNTERCLOCKWISE** to move **UP**

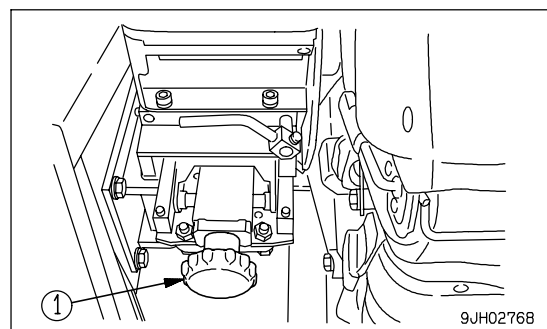

OPERATIONS AND CHECKS BEFORE STARTING ENGINE

⚠ WARNING

- When starting the engine, check and make sure the work equipment lock lever (4) and parking brake lever (1) are secured in the LOCK position.
If the control levers are not locked and they are touched by accident when starting the engine, the work equipment may move unexpectedly, and this may lead to a serious injury or death.
- When standing up from the operator's seat, always set the work equipment lock lever (4) and parking brake lever (1) to the LOCK position, regardless of whether the engine is running or stopped.

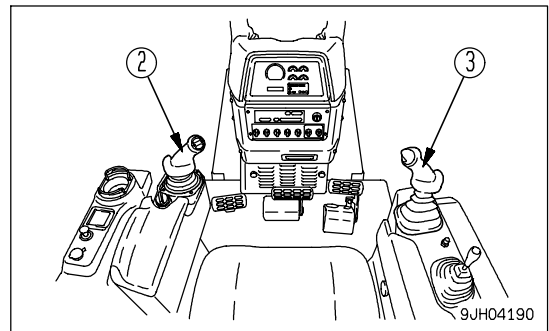
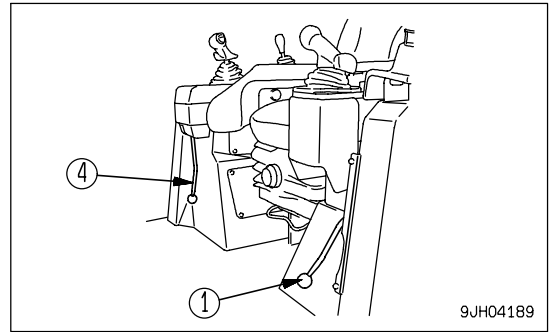

1. Check that parking brake lever (1) is in the LOCK position.

REMARK

If this parking brake lever is not in the LOCK position, the engine will not start.

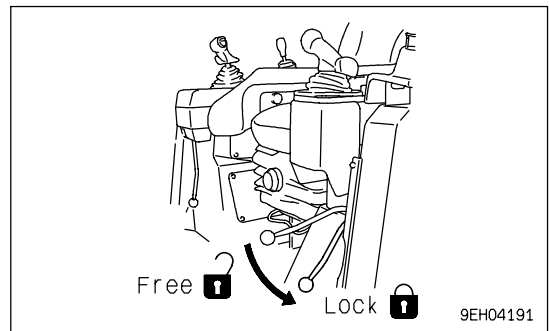

2. Check that steering, forward-reverse, gear shift lever (2) is in the N (neutral) position.

REMARK

- The engine cannot be started if steering, forward-reverse, gear shift lever (2) is not in the N (neutral) position.
- If steering, forward-reverse, gear shift lever (2) is in FORWARD or REVERSE, the letter P on display panel A will flash.

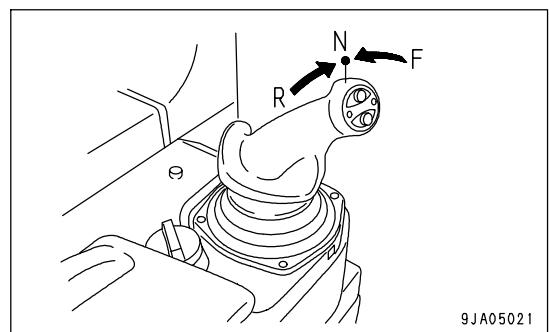

3. Check that the blade is lowered to the ground and that blade control lever (3) is in the HOLD position.

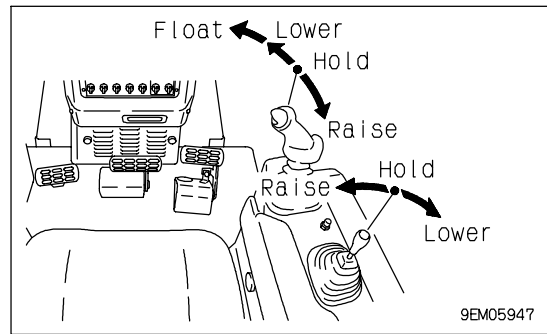

4. Check that the ripper is lowered to the ground.
5. Check that work equipment lock lever (4) is locked.
If work equipment lock lever (4) is locked, the blade control lever is returned to the HOLD position even if it is in the FLOAT position.

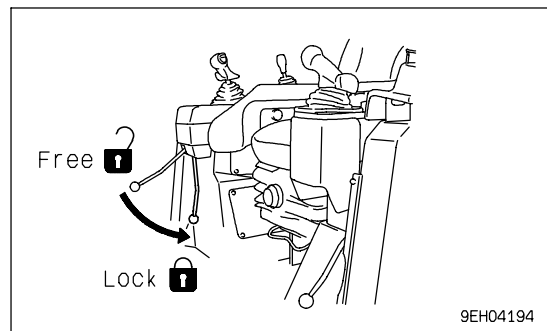

STARTING ENGINE

NORMAL STARTING



WARNING

- Sit down in the operator's seat before starting the engine.
- Do not attempt to start the engine by short-circuiting the engine starting circuit. Such an act may cause serious bodily injury or fire.
- Check that there are no persons or obstacles in the surrounding area, then sound the horn and start the engine.
- Exhaust gas is toxic. When starting the engine in confined spaces, be particularly careful to ensure good ventilation.

NOTICE

- Do not crank the starting motor continuously for more than 20 seconds. If the engine does not start, wait for at least 2 minutes, then repeat the procedure from Step 2.
- Before starting the engine, check that the fuel control dial is in the low idling (MIN) position.
- On this machine, to protect the turbocharger, a turbo protect function is provided. In cold weather, even if fuel control dial (1) is moved immediately after starting the engine, the engine speed may not change for several seconds.
- If the fuel control dial is in the FULL position, the engine will accelerate suddenly and cause damage to the engine parts, so set it to an intermediate or low speed position.

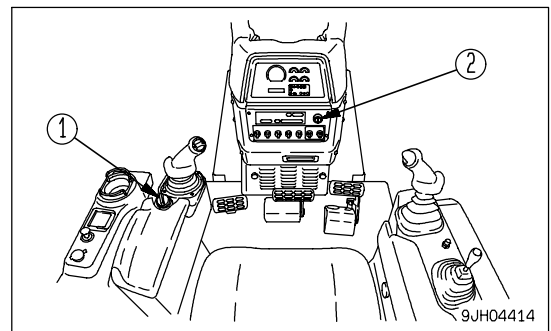

1. Turn fuel control dial (1) from the low idle (MIN) position to a slightly higher speed.

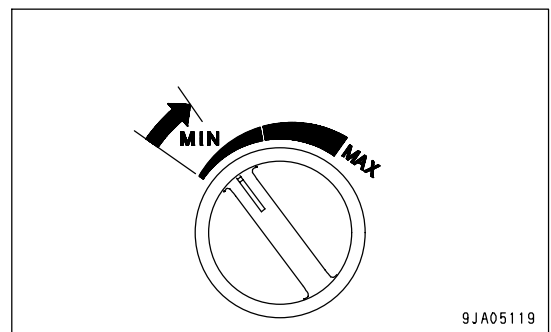

2. Insert the key into starting switch (2) and turn the key to the START position. The engine will start.

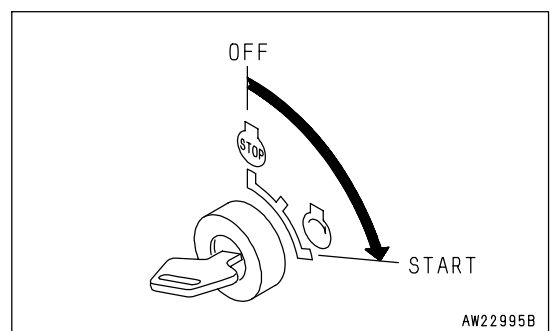

3. When the engine starts, release the key in starting switch (2).
The key will return automatically to the ON position.

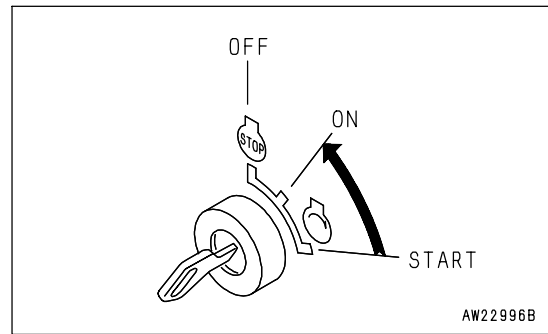

STARTING IN COLD WEATHER

**WARNING**

- Start the engine only after sitting down in the operator's seat.
- Do not attempt to start the engine by short-circuiting the engine starting circuit. Such an act may cause a serious bodily injury or fire.
- Check that there are no persons or obstacles in the surrounding area, then sound the horn and start the engine.
- Never use starting aid fluids as they may cause explosions.
- Exhaust gas is toxic. When starting the engine in confined spaces, be particularly careful to ensure good ventilation.

NOTICE

- Do not crank the starting motor continuously for more than 20 seconds. If the engine does not start, wait for at least 2 minutes, then repeat the procedure from Step 2.
- Before starting the engine, check that the fuel control dial is in the low idling (MIN) position.
- On this machine, to protect the turbocharger, a turbo protect function is provided. In cold weather, even if fuel control dial (1) is moved immediately after starting the engine, the engine speed may not change for several seconds.
- If the fuel control dial is in the FULL position, the engine will accelerate suddenly and cause damage to the engine parts, so set it to an intermediate or low speed position.

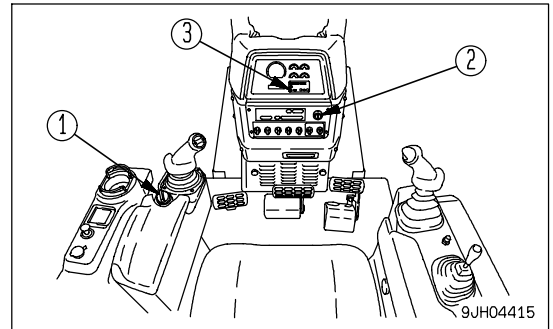

1. Turn fuel control dial (1) to the center position between MIN and MAX position.

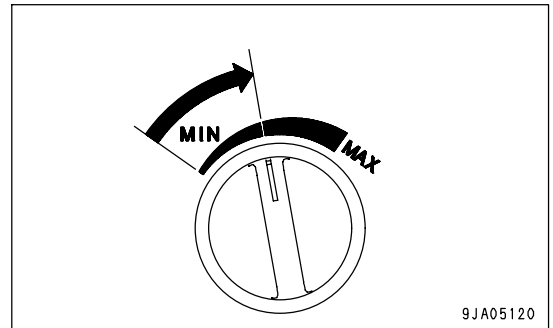

2. Turn the key of starting switch (2) to the ON position.

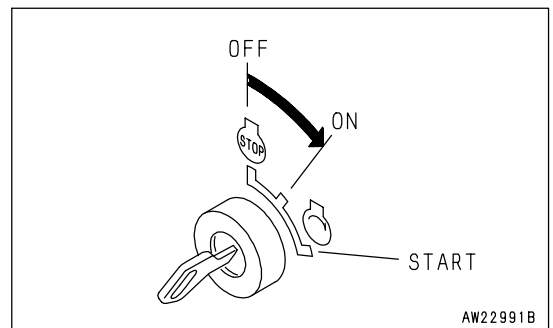

3. Check that engine pre-heating pilot lamp (3) on the monitor panel lights up.

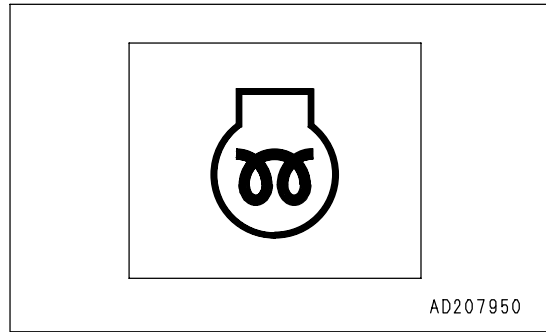

4. Maintain the key in the on position until the pre-heating pilot lamp (3) goes off.

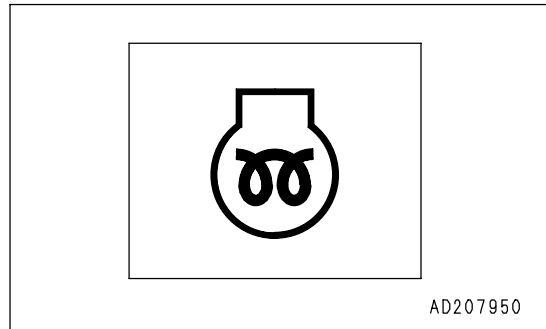

5. When engine pre-heating pilot lamp (3) goes off, turn the key of starting switch (2) to the START position to crank the engine.

The time that engine pre-heating pilot lamp (3) stays on changes according to the ambient temperature as shown in the table below.

Ambient temperature	Pre-heat time
-5°C to -10°C (23°F to 14°F)	20 to 27 seconds
-10°C to -20°C (14°F to -4°F)	27 to 40 seconds
-20°C to -30°C (-4°F to -22°F)	40 seconds

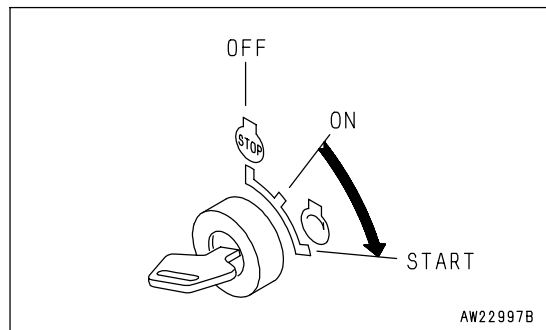

6. When the engine starts, release the key in starting switch (2). The key will return automatically to the ON position.

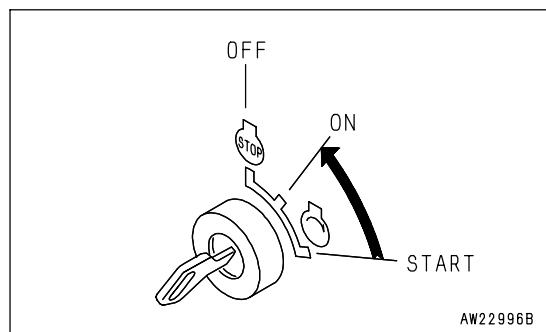

REMARK

Immediately after starting the engine, run at idle. While running the engine, release the decelerator pedal and do not operate the work equipment.

Guideline for idle time

- Cold weather: At least 15 seconds
- 1st start after changing engine oil or engine oil filter: 20 seconds

7. When the engine rotation stabilizes, return to the low idle (MIN) position of fuel control dial (1) and then carry out the warming-up operation.

REMARK

- Regardless of the ambient temperature, if the key in starting switch (2) is turned from OFF position to left, preheating pilot lamp (3) will light up and preheating will start. (Preheating continues while the starting switch is held at the left.)

For the details of the preheating time, see the table in Step 5.

- While preheating is being carried out, the preheating pilot lamp (3) lights up to show that preheating is being carried out.
- If the engine does not start with the above operation, wait for about 2 minutes, and repeat steps 3. And 4.
- The relationship between the actuation time of the turbo protect function and the engine coolant temperature is as follows.

Even if the fuel control dial is operated within the time given below, the engine speed will not change.

Turbo protect function

The turbo protect function is a function to protect the turbocharger by keeping the engine speed at less than 1000 rpm immediately after the engine is started.

- When the turbo protect function is actuated, the engine speed is held at less than 1000 rpm, regardless of the position of the fuel control dial.
- When the turbo protect function is actuated, the engine speed is held at less than 1000 rpm, even if the fuel control dial is operated.
- When the turbo protect function is canceled, the engine speed is set to the speed for the position of the fuel control dial.
- The relationship between the length of time of actuating the turbo protect function and the temperature of the engine coolant is as shown in the table.

Coolant temperature	Turbo protect time (sec.)
Above 10°C (50°F)	0
10 to -30°C (50 to -22°F)	Change 0 to 20
below -30°C (22°F)	20

OPERATIONS AND CHECKS AFTER STARTING ENGINE



WARNING

- If there has been any Emergency stop, abnormal actuation or trouble, turn the starting switch key to the OFF position.
- If the work equipment is operated without sufficiently warming the machine up, response of the work equipment to movement of the control lever will be slow, and the work equipment may not respond as the operator desires, so always perform the warming-up operation. Particularly in cold areas, be sure the warming-up operation is completed.

WARMING UP OPERATIONS

NOTICE

- Do not perform operations or suddenly operate the levers when the hydraulic oil is at a low temperature. Always perform the warming-up operation until the hydraulic oil temperature monitor displays the green range. This will help extend the machine life.
Do not suddenly accelerate the engine before the machine reaches full operating temperature.
- Do not run the engine at low or high idle for more than 20 minutes. This will cause oil leaks from the turbocharger oil supply piping.
If it is necessary to run the engine at idling, apply a load from time to time or run the engine at a mid-range speed.
- If engine oil pressure caution lamp (3) flashes or the buzzer sounds intermittently, stop the engine and check for the cause.

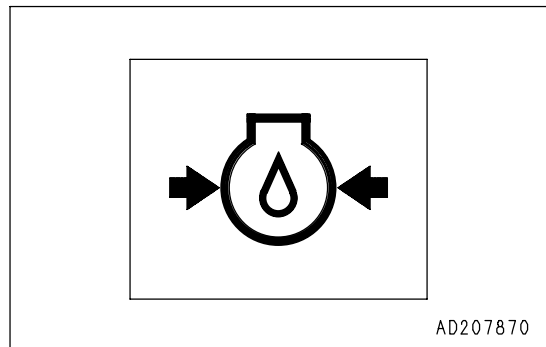
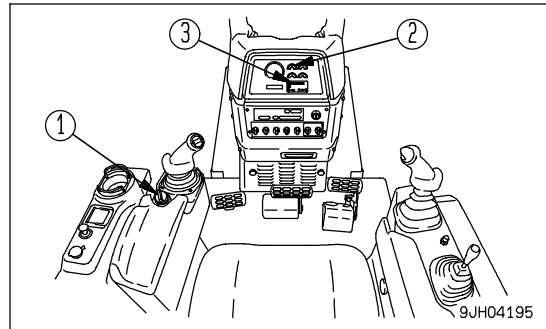

1. Turn fuel control dial (1) to the center position between low idling (MIN) and high idling (MAX) positions and run the engine at a mid-range speed for 5 minutes under no load.
2. After warm-up is completed, check gauges and caution lamps for proper operation. If any problem is found, repair it. Continue to run the engine under a light load until engine coolant temperature gauge indicator (2) is within the green range (B).
(A): White range
(B): Green range
(C): Red range

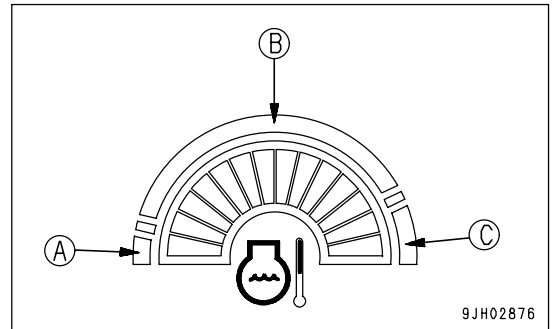
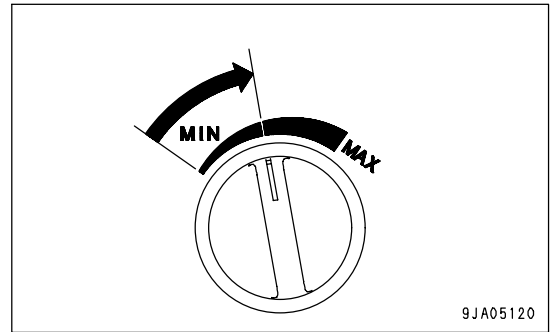

3. Check for abnormal exhaust gas color, noise, or vibration. If any problem is found, contact your Komatsu distributor.

IN COLD AREAS

(Ambient temperature below 10°C (50°F))

NOTICE

- Do not perform operations or suddenly operate the levers when the hydraulic oil is at a low temperature. Always perform the warming-up operation until the hydraulic oil temperature monitor displays the green range. This will help extend the machine life.
Do not suddenly accelerate the engine before the machine reaches full operating temperature.
- Do not run the engine at low or high idle for more than 20 minutes. This will cause oil leaks from the turbocharger oil supply piping.
If it is necessary to run the engine at idling, apply a load from time to time or run the engine at a mid-range speed.
- If engine oil pressure caution lamp (3) flashes or the buzzer sounds intermittently, stop the engine and check for the cause.

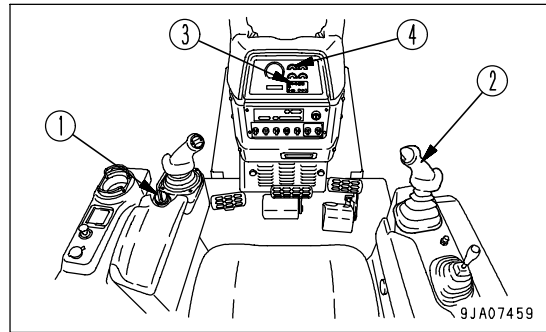

1. Turn fuel control dial (1) to the center position between LOW IDLE (MIN) and HIGH IDLE (MAX) and run the engine at medium speed for about 5 minutes with no load.

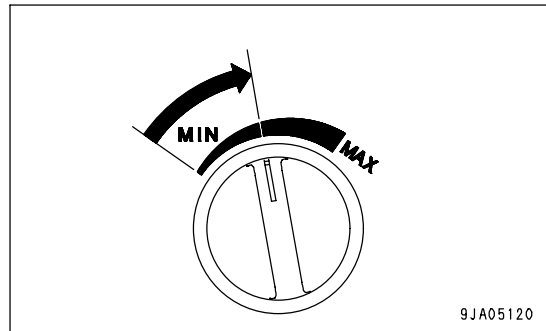

2. Blade control lever (2) to the full RAISE position, then hold the lever in position, and operate slowly to the left tilt relief and right tilt relief positions for 5 minutes.
3. Finally, operate blade control lever (4) and ripper control lever to operate the blade and ripper cylinders several times.
If the oil temperature in the work equipment is not properly raised, there will be a time lag in the response of the work equipment and steering.
4. After warm-up is completed, check gauges and caution lamps for proper operation. If any problem is found, repair it.
Continue to run the engine under a light load until engine coolant temperature gauge indicator (4) is within the green range (B).

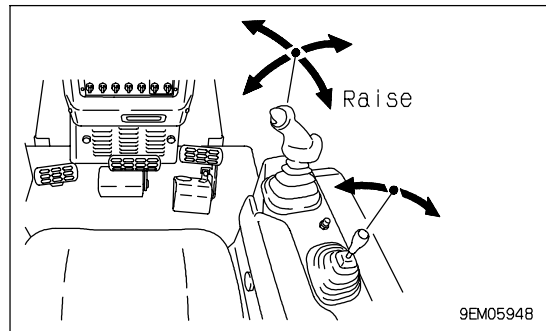

- (A): White range
- (B): Green range
- (C): Red range

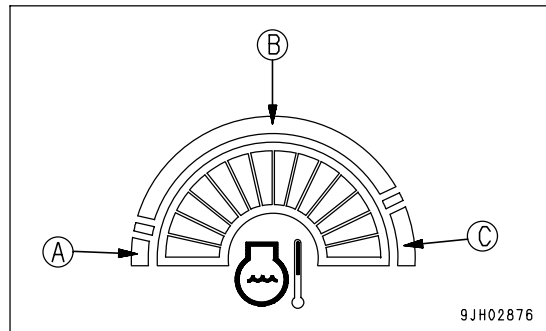

REMARK

If the power train oil temperature is not raised sufficiently, it will take longer to accelerate to the maximum speed.

5. Check for abnormal exhaust gas color, noise, or vibration. If any problem is found, contact your Komatsu distributor.

STOPPING ENGINE

NOTICE

If the engine is stopped without allowing it to cool down, there is danger that the service life of various parts of the engine will be reduced. Except in emergencies, never stop the engine suddenly.

If the engine overheats, do not stop it suddenly. Run it at low speed to allow it to cool down gradually, then stop it.

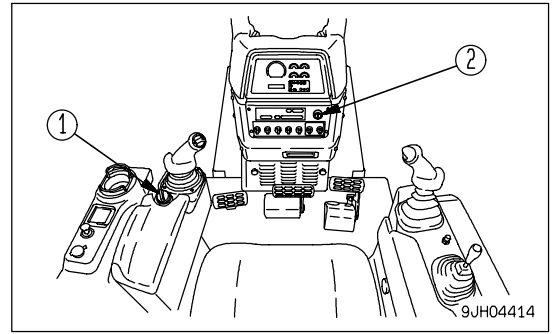

1. Lower the work equipment to the ground.
2. Turn fuel control dial (1) in the low idling (MIN) positions and run the engine at low idling speed for 5 minutes to allow the engine to gradually cool down.

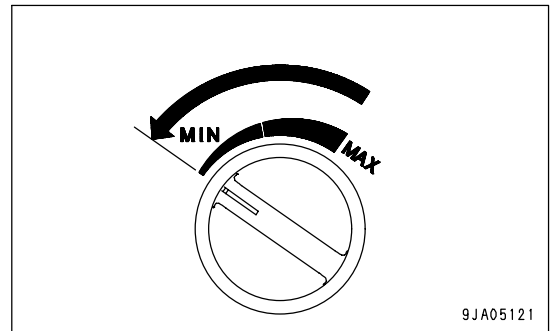

3. Turn the key in starting switch (2) to the OFF position.
The engine will stop.

REMARK

- When the key in starting switch (2) is turned to the OFF position, the engine stops, but the machine power supply is not cut immediately.
The power supply is maintained for several seconds to enable the controller to save the operating condition to memory and shuts down the system after that. The length of time that the power supply is maintained depends on the operating condition.
- Even when the cooling fan is being operated in reverse or in the cleaning mode, the machine power supply is not cut immediately when the key in starting switch (2) is turned to the OFF position.
The power supply is maintained for seven seconds to protect the hydraulic circuit. During that time, the fan operation confirmation lamp on the monitor panel flashes.

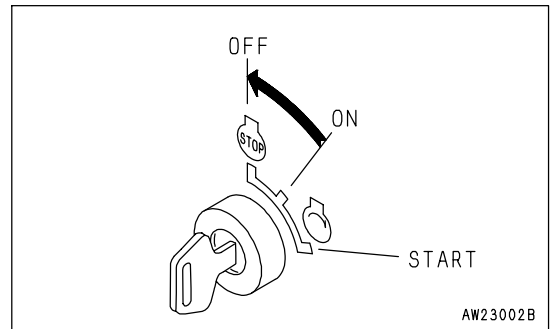

4. Remove the key from starting switch (2).

MACHINE OPERATION

MOVING MACHINE

WARNING

- Before moving the machine, check that the area around the machine is safe, and always sound the horn before moving.
Do not allow anyone to enter the area around the machine.
The rear of the machine is a blind spot, so be extremely careful when traveling in reverse.
- When moving the machine down a slope, always keep brake pedal (8) depressed, even after releasing parking brake lever (1).
- When moving the machine up a steep slope, turn fuel control dial (5) to high idling (MAX) position and run the engine at full speed, and keep brake pedal (8) and decelerator pedal (6) depressed. Then operate steering, directional, and gearshift lever (4) from the N (neutral) position to the direction of travel and slowly release brake pedal (8). When the travel speed rises, slowly release decelerator pedal (6).

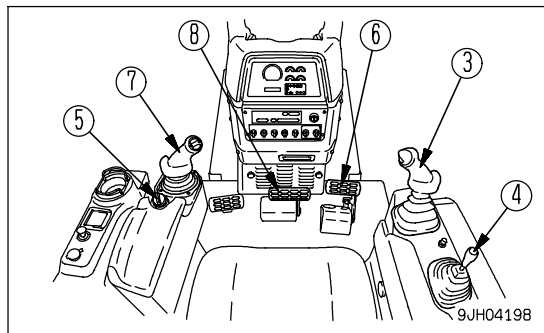
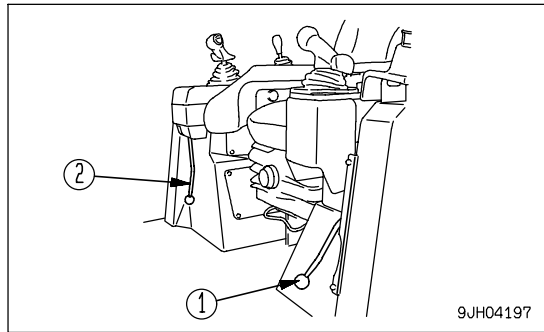

1. Set parking brake lever (1) to the FREE position.

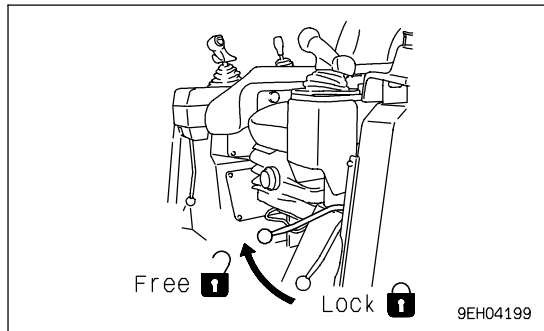

2. Set work equipment lock lever (2) for blade control lever (3) and ripper control lever (4) to the FREE position.

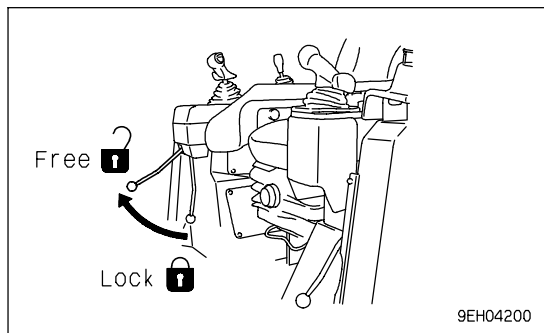

- Operate blade control lever (3) and ripper control lever (4) to the RAISE position, raise the blade 40 - 50 cm (15.8 - 19.7 in) from the ground, and raise the ripper to the maximum height.

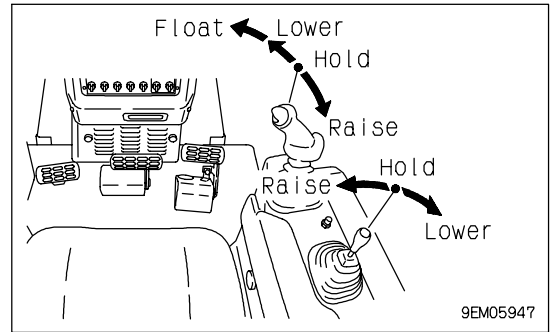

- Turn fuel control dial (5) to the full speed (MAX) position, raise the engine speed, and fully depress decelerator pedal (6).

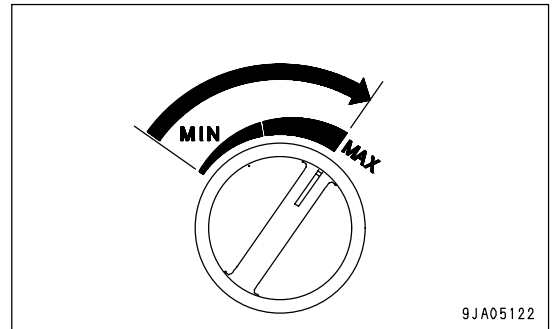

- Move joystick to the F (FORWARD) or R (REVERSE) position, gradually release decelerator pedal (6) and allow the machine to move.

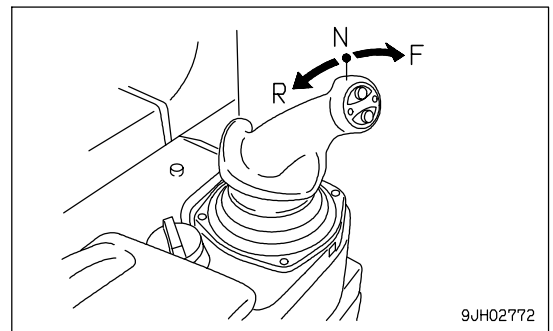

REMARK

Check that the backup alarm sounds when steering, forward-reverse, gear shift lever is placed in REVERSE position. If the alarm does not sound, please contact your Komatsu distributor.

STOPPING MACHINE

! WARNING

- Avoid stopping suddenly. Give yourself ample room when stopping.
- When stopping the machine, select flat hard ground and avoid dangerous places. If it is unavoidably necessary to park the machine on a slope, place the parking brake lever (1) in the LOCK position and insert blocks underneath the track shoes. As an additional safety measure, thrust the blade into the ground.
- If the work equipment control lever is touched by accident, the work equipment may suddenly move, and may cause damage, serious injury, or death. Before leaving the operator's seat, always secure work equipment lock lever (2) in the LOCK position.

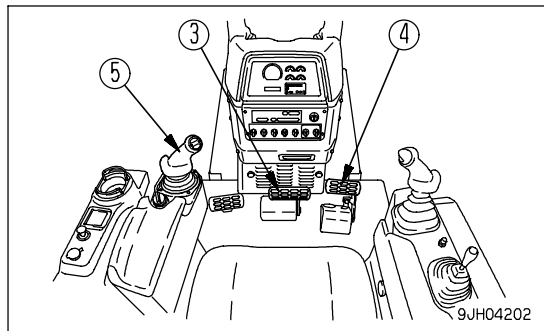
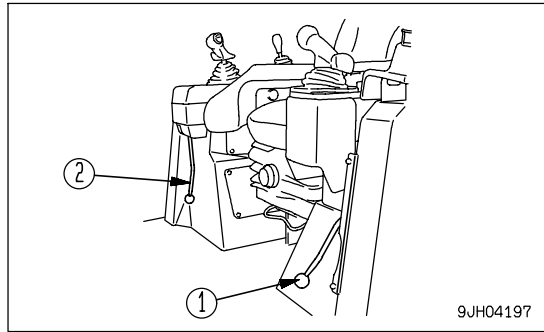

1. Depress brake pedal (3) to apply the brake.

NOTICE

If the brake is depressed when the engine speed or travel speed is high, the brake disc may make a slipping sound. Normally, depress decelerator pedal (4) to reduce the engine speed and travel speed before depressing the brake.

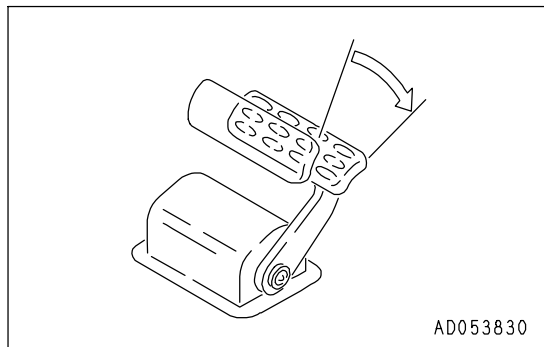

2. Set joystick (5) in the neutral position.

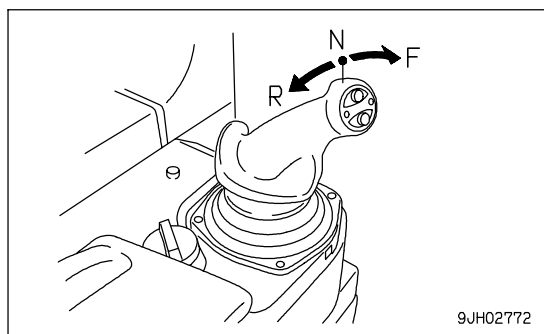

SHIFTING GEAR

The machine does not have to be stopped to shift gears.

1. Move steering, forward-reverse, gear shift lever (1) to the desired gear position to shift gears.

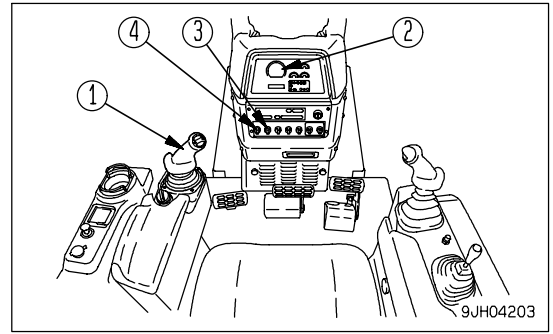

GEAR SHIFTING

Press switch (a) or (b) to shift gears.

Up switch (a): Each time switch is pressed, transmission shifts up 1 range

Down switch (b): Each time switch is pressed, transmission shifts down 1 range

There are 3 forward and 3 reverse speed ranges.

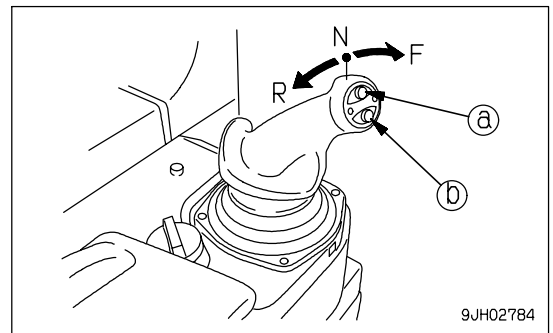

- When the lever is moved to the forward (to set to FORWARD) from the N position, the transmission shifts to F1. If the UP switch is pressed once when the transmission is in F1, the transmission shifts to F2. If the UP switch is pressed once when the transmission is in F2, the transmission shifts to F3. If the DOWN switch is pressed once when the transmission is in F3, the transmission shifts to F2. If the DOWN switch is pressed once when the transmission is in F2, the transmission shifts to F1.
- When the lever is moved to the rear (to set to REVERSE) from the N position, the transmission shifts to R1. If the UP switch is pressed once when the transmission is in R1, the transmission shifts to R2. If the UP switch is pressed once when the transmission is in R2, the transmission shifts to R3. If the DOWN switch is pressed once when the transmission is in R3, the transmission shifts to R2. If the DOWN switch is pressed once when the transmission is in R2, the transmission shifts to R1,

For details of the maximum speed in each speed range, see "SPECIFICATIONS (PAGE 5-2)".

REMARK

The speed range in use is displayed on the panel display according to the gearshift operation.

For example:

- Neutral: N is displayed on the display panel A (2)
- FORWARD 2nd: F2 is displayed on the display panel A (2)
- REVERSE 3rd: R3 is displayed on the display panel A (2)
- When the parking brake lever is locked, P is displayed.

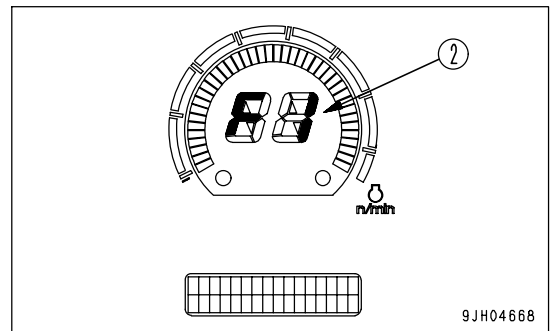

GEARSHIFTING OPERATION USING PRESET MODE FUNCTION

If the preset mode function is used, the speed ranges used when the machine travels in forward and reverse can be preset as desired.

- F1-R1 mode
- F1-R2 mode
- F2-R2 mode

1. Set joystick (1) to the N position.

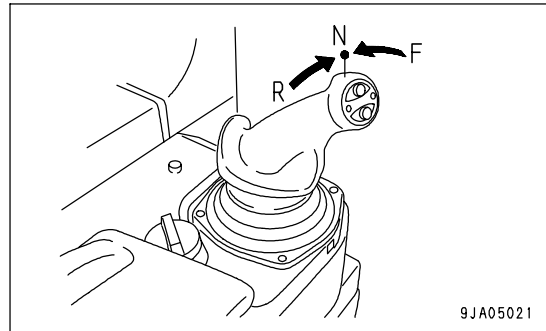

2. When preset mode switch (3) is set to the I position (ON), the function is actuated.

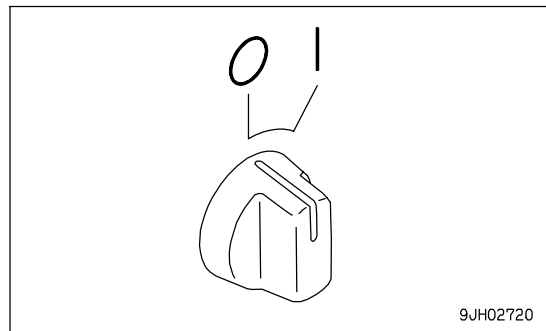

3. When the preset mode function is actuated, [F1-R1] is displayed at the left side of the bottom line of display panel B (multi-information) on the monitor panel, and the [F1-R1] mode is set.

REMARK

When preset mode switch (3) is set to the ON position (a), the default [F1-R1] mode is set.

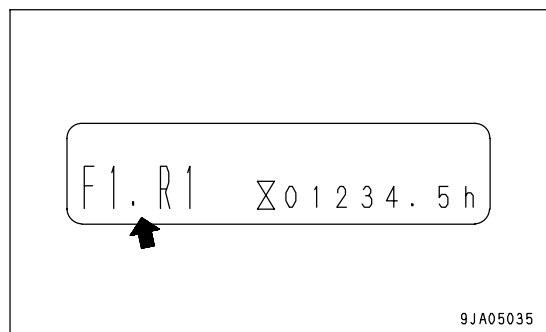

4. If it is desired to select another mode, press up switch (a) or down switch (b) on steering, directional, and speed lever (1) and display the desired mode on control panel B (multi-information).

The types of mode and method of selection are as follows.

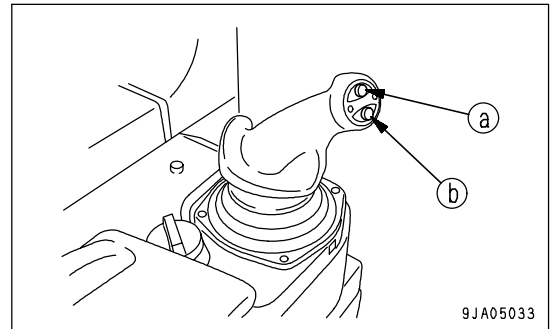
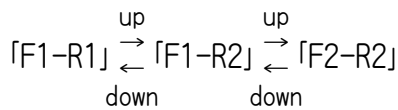

- Shift operation when [F1-R1] mode is set
When the preset mode switch is turned ON, the [F1-R1] mode is set by default. After that, if the steering, directional, and speed lever is operated forward (forward travel operation), the transmission is shifted to F1. If it is operated back (reverse travel operation), the transmission is shifted to R1.
- Shift operation when [F1-R2] mode is set
When the steering, directional, and speed lever is in the N position, if the up switch is pressed once, the mode is set to [F1-R2] mode. After that, if the steering, directional, and speed lever is operated forward (forward travel operation), the transmission is shifted to F1. If it is moved back (reverse travel operation), the transmission is shifted to R2.
- Shift operation when [F2-R2] mode is set
When the steering, directional, and speed lever is in the N position, if the up switch is pressed twice, the mode is set to [F2-R2] mode. After that, if the steering, directional, and speed lever is operated forward (forward travel operation), the transmission is shifted to F2. If it is moved back (reverse travel operation), the transmission is shifted to R2.

REMARK

Even when the mode is set to [F1-R1] mode, [F1-R2] mode, or [F2-R2] mode, it is possible to switch to the desired speed range simply by operating the up switch or down switch.

For example, when the mode is set to [F1-R2] mode, if the steering, directional, and speed lever is moved forward (forward travel operation), the transmission is shifted to F1, but if up switch (a) is pressed once with the lever pushed forward, the transmission is shifted to F2; if it is pressed twice, the transmission is shifted to F3. If the down switch (b) is pressed once when the transmission is in F3, the transmission is shifted to F2; if it is pressed twice, the transmission is shifted to F1.

If the steering, directional, and speed lever is moved back (reverse travel operation), the transmission is shifted to R2, but if up switch (a) is pressed once with the lever pulled back, the transmission is shifted to R3; if down switch (b) is pressed once, the transmission is shifted to R1.

However, the mode remains in the [F1-R2] mode. If the steering, directional, and speed lever is returned to the N position and operated forward again (forward travel operation), the transmission is shifted to F1. If it is moved back (reverse travel operation), the transmission is shifted to R2.

AUTO SHIFT DOWN FUNCTION

If the travel speed drops because of the load conditions when traveling, this function automatically down shifts to a lower speed range.

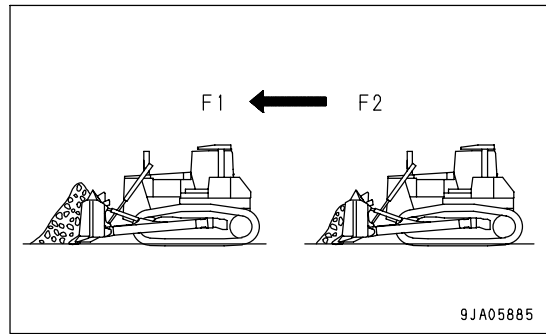

1. The function is actuated when auto shift down switch (4) on the front panel is set to I position (ON).

- (OFF) position: Canceled
- I (ON) position: Actuated

The transmission is automatically shifted down F2→ F1, F3 → F2, R2 → R1, R3 → R2.

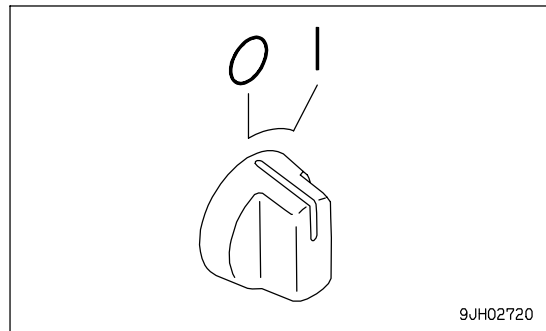

REMARK

When the preset mode is being actuated, to ensure safety, the system is set so that it does not shift up after the auto shift down has been actuated.

If it is desired to shift up, operate the up switch manually. However, the preset mode remains set. If the steering, directional, and speed lever is returned to the N position and then operated again to the forward or reverse position, the preset speed range is again selected.

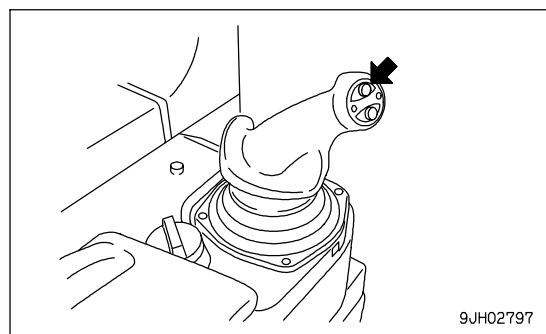
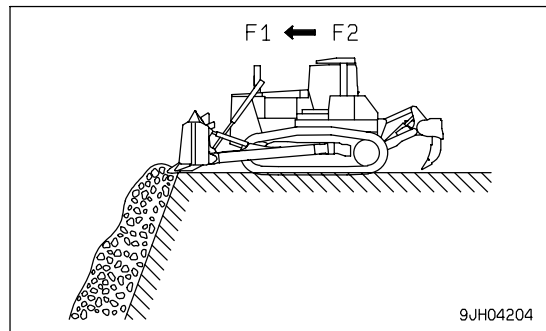

SHIFTING BETWEEN FORWARD AND REVERSE

**WARNING**

When switching between FORWARD and REVERSE, first check that the direction of travel is safe.

**CAUTION**

There is no need to stop the machine even when switching between FORWARD and REVERSE.

To increase safety, operator comfort, and the life of the transmission, leave the engine running at full speed, and always depress the decelerator pedal to lower the engine speed.

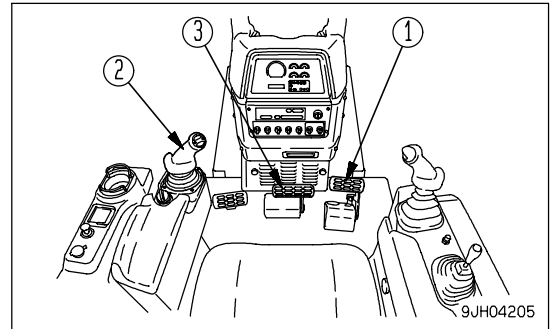

1. Depress decelerator pedal (1) to reduce the engine speed.

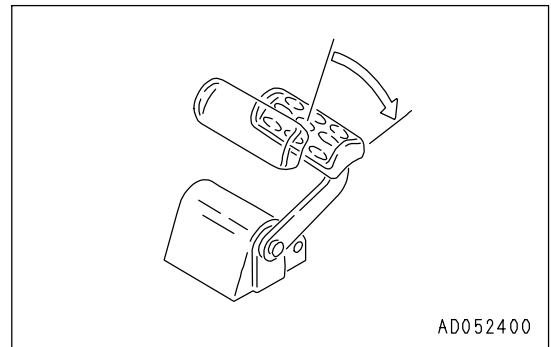

2. Move joystick (2) to the neutral position, reduce the speed, then depress brake pedal (3) and stop the machine.

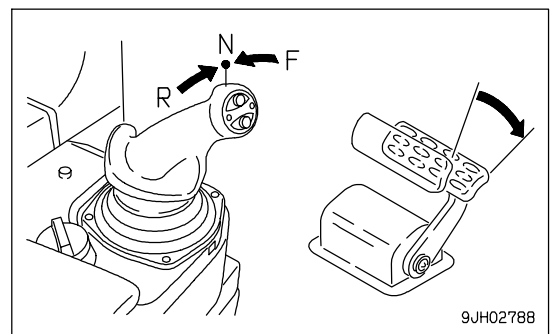

3. After depressing decelerator pedal (1), move steering, forward-reverse, gear shift lever (2) to the desired position.

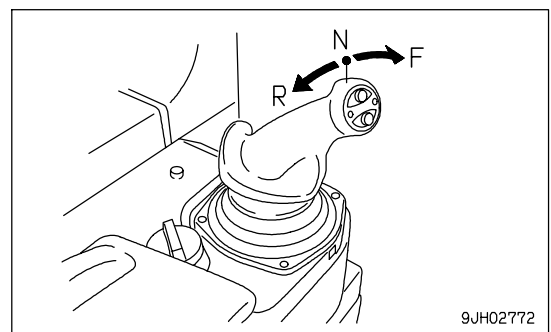

4. Release decelerator pedal (1) and raise the engine speed.

REMARK

Check that the backup alarm sounds when steering, forward-reverse, gear shift lever is placed in REVERSE position. If the alarm does not sound, please contact your Komatsu distributor.

REMARK

When the joystick is placed in REVERSE, the backup alarm will sound.

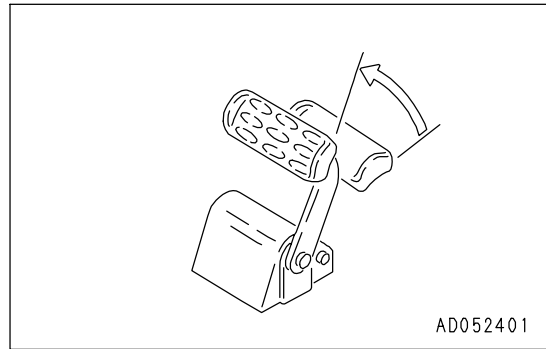

STEERING MACHINE



WARNING

- Avoid as much as possible turning the machine on a slope.
The machine will tend to slip sideways. Particular care should be taken on soft or clay soil.
- Never make a pivot turn at high speed.

NORMAL TURNING



WARNING

When performing a counterrotation turn, the feeling of operation when your head is facing the rear is different from the feeling if you are facing the front. Never carry out a counterrotation turn while facing the rear.

To turn the machine while traveling, incline steering, forward-reverse, gear shift lever (1) in the direction of the turn.

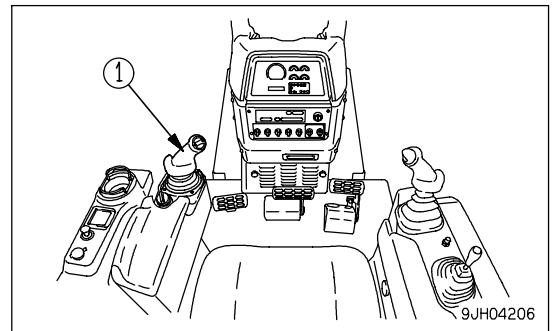

TURNING GRADUALLY TO LEFT WHILE TRAVELING FORWARD

NOTICE

If the lever is moved partially to the forward or reverse position and then is moved in the direction of turn, the machine may carry out a counterrotation turn, so operate the lever fully to the forward or reverse position.

If steering, forward-reverse, gear shift lever (1) is moved to the FORWARD position (F) and moved partially to the left (L), the machine will start to turn gradually. After that, the lever can be moved further towards the end of its travel to set the desired turning radius.

REMARK

To turn gradually to the right while traveling forward, if the steering, forward-reverse, gear shift lever (1) is operated to the FORWARD position (F) and moved slowly to the right, the machine will start to turn gradually. After that, the lever can be moved further towards the end of its travel to set the desired turning radius.

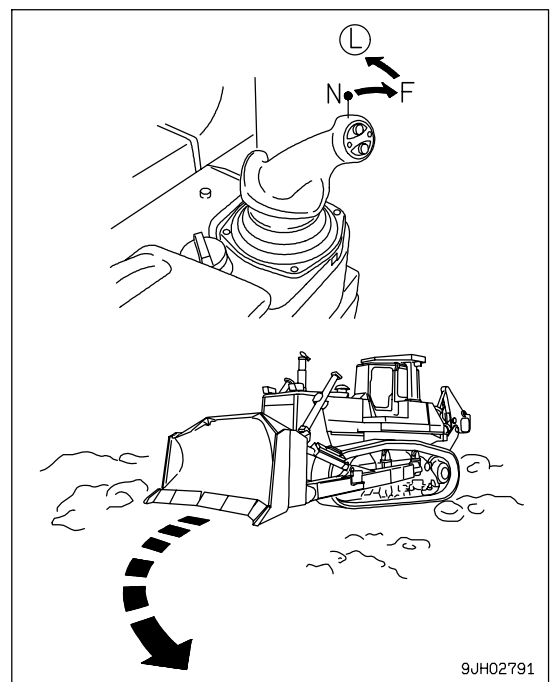

COUNTERROTATION TURNS TO LEFT WHEN TRAVELING FORWARD

NOTICE

When carrying out a counterrotation turn, if the load is not equal on the left and right sides, the machine may carry out a pivot turn, so check the ground conditions and be careful not to hit any obstacles.

With steering, forward-reverse, gear shift lever (1) in the N position, operate the lever partially to the left (L). The left and right tracks will rotate in opposite directions, and the machine will make a slow counterrotation turn. If the lever is moved further, the speed of the counterrotation turn will increase.

REMARK

When making a right counterrotation turn, move the steering, forward-reverse, gear shift lever (1) to the right (R) in the same way.

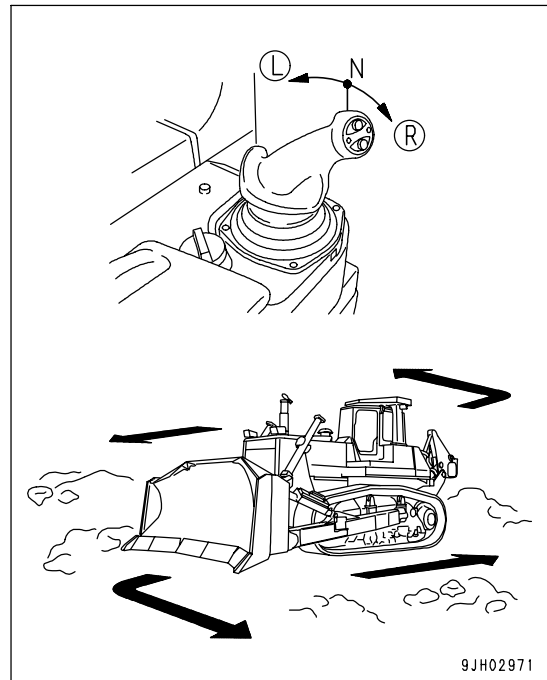

TURNING WHILE DESCENDING A SLOPE

TURNING GRADUALLY TO LEFT WHILE TRAVELING FORWARD

If steering, forward-reverse, gear shift lever (1) is moved to the FORWARD position (F) and moved partially to the left (L), the machine will start to turn gradually. After that, the lever can be moved further towards the end of its travel to set the desired turning radius.

REMARK

To turn gradually to the right while traveling forward, if the steering, forward-reverse, gear shift lever (1) is operated to the FORWARD position (F) and moved slowly to the right, the machine will start to turn gradually. After that, the lever can be moved further towards the end of its travel to set the desired turning radius.

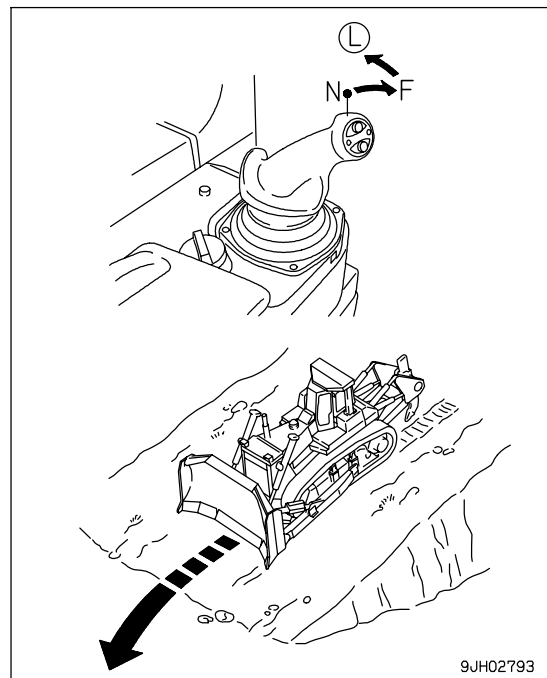

PRECAUTIONS FOR OPERATION

PAY ATTENTION TO GAUGES

If the red range of the power train oil temperature gauge lights up during operation, reduce the load and wait for the temperature to go down.

PERMISSIBLE WATER DEPTH

When operating in water, always keep top surface of the track frame above the surface of the water.

Also, be careful that the engine cooling fan will not come in contact with water. The fan can be damaged.

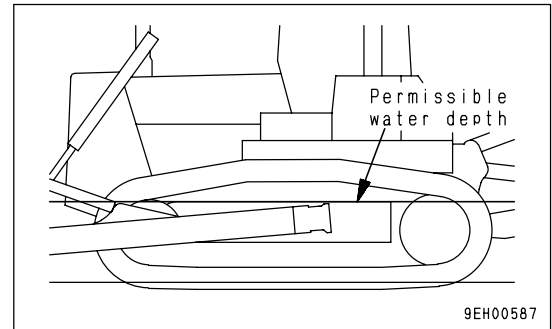

PRECAUTIONS WHEN TRAVELING FOR A LONG TIME

Avoid operating the machine at high speed for a long time, otherwise the temperature of hydraulic oil sharply rises, and that can cause oil leakage from the track rollers or final drive and lower durability.

If there is no way to avoid operating the machine at high speed for a long time, stop the machine every one hour for 30 minutes and let the track rollers and final drive cool off before starting up the machine again.

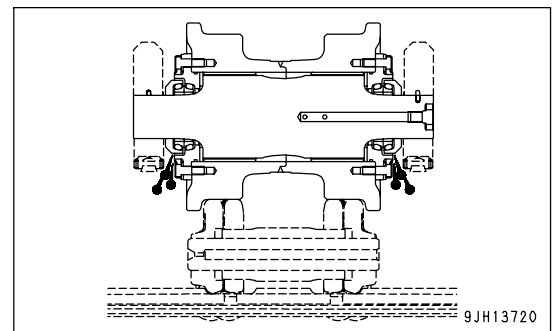

PRECAUTIONS WHEN TRAVELING UP OR DOWN HILLS

METHOD OF USING DECELERATOR PEDAL

When stepping on the decelerator pedal while going uphill, climbing ability will be reduced and the machine will stop. Furthermore, the engine may stall.

USE ENGINE AS BRAKE

When going downhill, move steering, forward-reverse, gear shift lever into low speed to run engine at slow speed and travel down slope using the engine as a brake.

Do not move the steering, forward-reverse, gear shift lever to the NEUTRAL position.

When traveling down hills of more than 15°, shift down to 1st speed (R1 or F1).

BRAKING WHEN TRAVELING DOWNHILL

While descending a slope using the engine as a brake, also apply the brakes.

Failure to brake may result in overrunning, causing engine trouble.

PRECAUTIONS WHEN OPERATING BLADE

METHOD OF USING BLADE LIFT CYLINDER

Do not carry out back grading operations with the cylinder fully extended. There is high risk that an excessive load will be brought to bear on the cylinder.

PRECAUTIONS ON SLOPE

BE CAREFUL OF FUEL LEVEL

- If the fuel level in the fuel tank becomes low when the machine is working on slopes, the engine may suck in air because of the angle of the machine or the swaying of the machine. This may make the engine stop, so be careful not to let the fuel level in the fuel tank become too low.
- When working on slopes where the angle of the machine is more than 20°, if the 2nd level of the fuel gauge lights up, add fuel immediately.

(A): Red range

(B): Green range

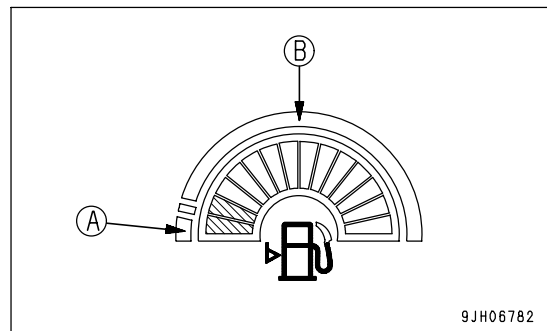

BE CAREFUL OF OIL LEVEL

When operating machine on sloped areas of more than 20°, fill all appropriate components with oil to H level.

PRECAUTIONS WHEN ENGINE STOPS ON SLOPE

If the engine stops while working or traveling on a hill, immediately depress the brake pedal to bring the machine to a complete stop.

METHOD OF USING BRAKES

The following actions cause premature damage to the brakes, so avoid such operations.

- Using emergency brake at full speed
- Using brake with engine running at full speed in first gear (F1, R1) (Machine stall condition)

REMARK

Always depress the decelerator pedal to lower the engine speed before actuating the brakes.

PROHIBITED TO KEEP THE DOOR OPEN DURING OPERATIONS

Always keep the door closed when traveling or carrying out operations.

If the door is open, there is danger of damage from obstacles or strong vibration.

IT IS PROHIBITED TO MODIFY THE CAB GLASS IN ANY WAY THAT WILL OBSTRUCT THE VIEW

- For safety reasons, do not install anything on the cab glass that will obstruct the view.
- Always keep the glass clean to ensure safety during operations.

PRECAUTIONS FOR BLIND SPOTS CAUSED BY CAB STAY AND ROPS STAY



WARNING

The cab stay and ROPS stay cause blind spots.

When operating, always be sure to check carefully that there is no obstacle or worker in the surrounding area.

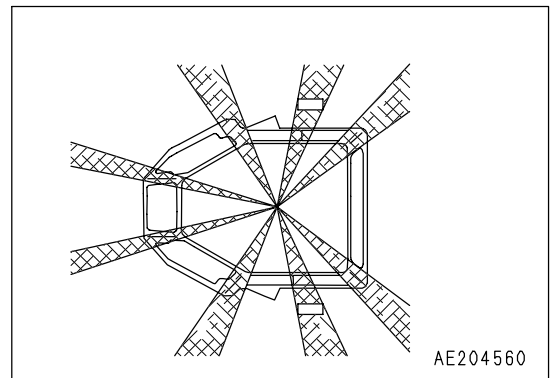

WORK POSSIBLE USING BULLDOZER

In addition to the following, it is possible to further increase the range of applications by using various attachments.

DOZING

A bulldozer digs and transports dirt in a forward direction. Slope excavation can always be most effectively carried out by proceeding from the top downward.

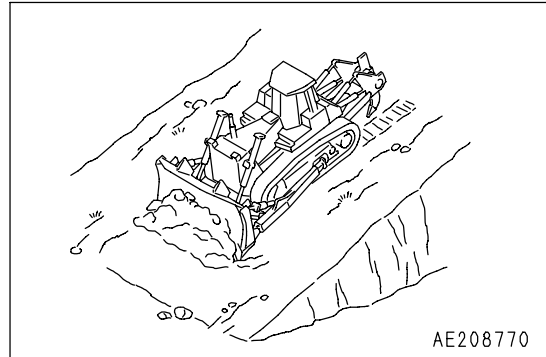

CUTTING INTO HARD OR FROZEN GROUND OR DITCHING

For digging and ditch excavation of hard or frozen ground tilt the blade. Even hard ground can be dug effectively by a tilted or angled blade.

If the ground is harder, use a ripper attachment for better efficiency.

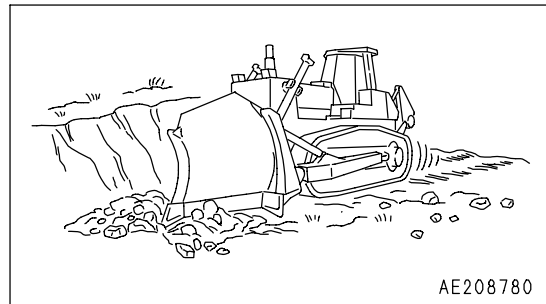

FELLING TREES, REMOVING STUMPS

NOTICE

Do not up root trees or stumps or fell trees by angling or tilting the blade.

For trees with a diameter of 10 to 30 cm (3.9 to 11.8 in), raise the blade high and push 2 or 3 times to fell the tree.

Next, travel in reverse, and dig the corner of the blade into the ground to cut and dig up the roots.

When doing this, never hit the tree at high speed or apply shock to fell the tree.

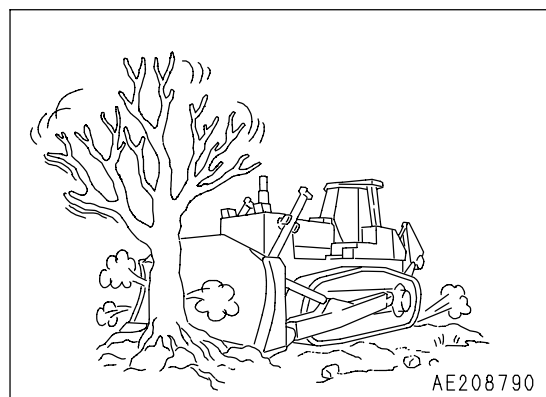

PUSHER OPERATIONS

- When carrying out pusher operations, always install a pusher plate.
- When approaching the other machine, depress the decelerator pedal to reduce the engine speed and approach slowly. After coming into contact, raise the travel speed slowly and push with full power.

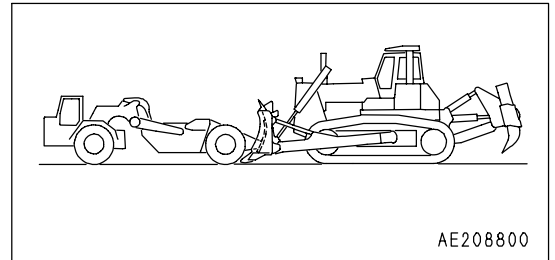

SMOOTHING

NOTICE

Avoid smoothing on rocky or stony ground. It can damage the blade.

When finishing the ground surface to a smooth finish after digging or filling operations, keep a full load of soil in the blade and operate the blade up or down in small movements while traveling forward. When leveling windrows or ruts left by the tracks, set the blade to the FLOAT position, travel at low speed in reverse and drag the blade over the ground surface.

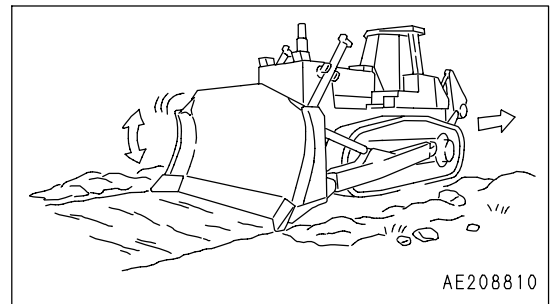

ADJUSTING POSTURE OF WORK EQUIPMENT

 **WARNING**

When adjusting, it is dangerous if the work equipment is moved by mistake. Set the work equipment in a safe condition, then stop the engine and lock the work equipment securely with the work equipment lock lever.

BLADE ADJUSTMENT

TILTING THE TILTDOZER

NOTICE

The maximum tilt is 750 mm (29.6 in) for the EX specification machine and 500 mm (19.7 in) for the PX specification machine. When tilting, make sure that it does not exceed 750 mm (29.6 in) for the EX specification machine or 500 mm (19.7 in) for the PX specification machine.

If the maximum tilt is exceeded, excessive force will be brought to bear on all parts, and this will damage the machine.

If the blade control lever is operated, the following tilt amount can be obtained.

Right side: 410 mm (16.2 in)

Left side: 410 mm (16.2 in)

If more tilt is required, do as follows.

Use bar handle (2) installed to the left brace to turn brace (1) and change length (L) of the brace. This makes it possible to obtain a maximum tilt of 750 mm (29.6 in) for the EX specification machine and 500 mm (19.7 in) for the PX specification machine.

- Standard distance between joints (L): 1287 mm (50.7 in)

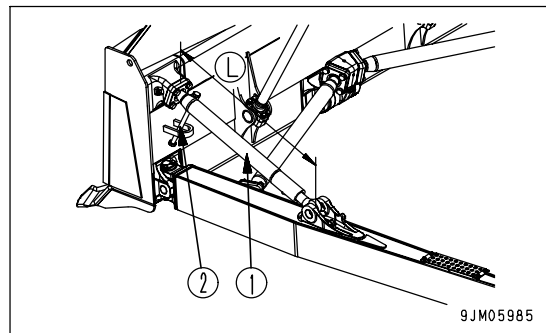

ADJUSTING SHIM IN BLADE CYLINDER CAP

Set the standard shim adjustment in the blade cylinder cap to 4 mm (0.16 in).

Remove shims to balance the wear of the cap and the ball at the end of the piston rod.

The proper clearance to be maintained with the shims is 0.2 to 0.5 mm (0.008 to 0.02 in).

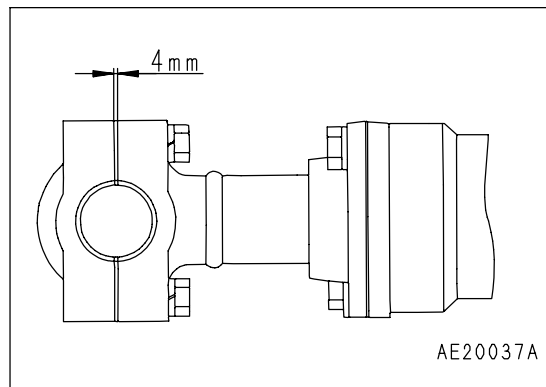

ADJUSTING DIGGING ANGLE

(PX Specifications)

It is possible to change the digging angle (A) of the blade by removing cap (1) and bolt (2) installed between the blade and tilt cylinder or brace (3), or replacing with optional parts.

This is extremely effective in improving the earth rolling function of the blade on soft ground without using the tilt cylinder to change the left and right tilt.

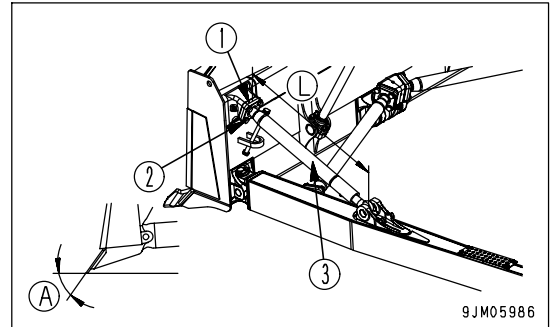

1. When replacing with optional cap (1) and bolts (2)

Digging angle (A): 55° -> 52.5°

Part numbers for replacement parts

- Cap (1): 154-929-3210 (2 caps/machine)
- Bolt (2): 01011-82420 (8 bolts/machine)

2. When removing cap (1) installed to standard machine

Digging angle (A): 55° -> 50.5°

Prepare the following parts for bolts (2) and replace.

- Bolt (2): 01010-82490 (8 bolts/machine)

REMARK

It is possible to change digging angle (A) of the blade by a range of $\pm 5^{\circ}$ by changing the length (L) of the brace and tilt cylinder.

However, the more the digging angle is changed, the more the change becomes in the amount of tilt on the left and right sides provided by the tilt cylinder.

ADJUSTING BRACE



WARNING

If maintenance is carried out with the engine running, always have one worker sitting in the operator's seat while another worker carries out the maintenance. Both workers must mutually confirm the safety during the operation.

Start the engine, then use fine operation of the blade control lever to tilt to the left and right. Move the blade up and down while rotating the brace handle. This makes the adjustment operation easier.

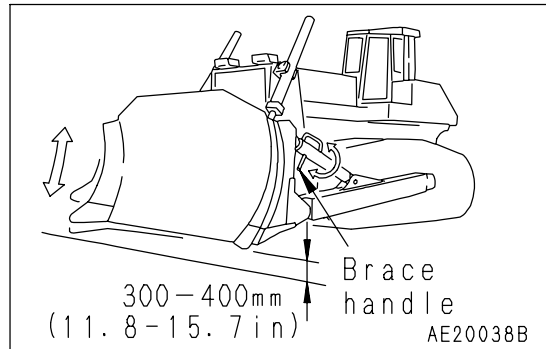

- When extending the brace

It is easy to carry out the adjustment if the blade is set on top of a block and the brace handle is turned.

REMARK

When operated in this way, the blade is tilted, so the handle gradually becomes heavier. When this happens, return the blade from the tilt position to the horizontal position and turn the handle again according to the procedure given above.

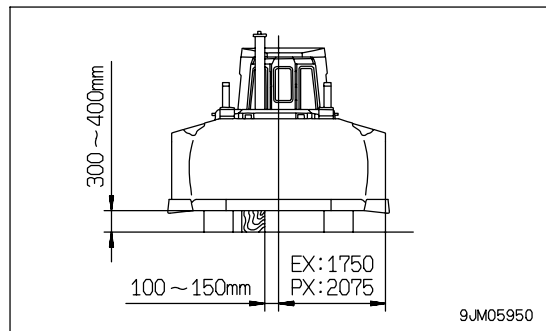

SHIM ADJUSTMENT

Adjust the thickness of shim so that the ball joint play (6 points) in the axial direction (shown by the arrow) does not exceed 1 mm (0.04 in).

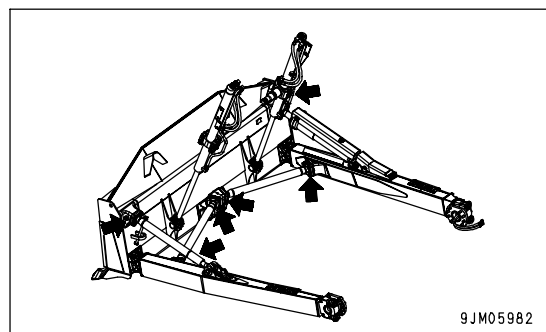

1. Remove shim (1) and tighten bolts (2) to eliminate the ball joint play.
2. Measure clearance "A" and remove bolts (2).
3. Adjust the thickness of shim (1) to $(A + 0.5) - (A + 1)$ mm, then tighten bolt (2).
4. Confirm that ball joint can move smoothly after tightening bolts.

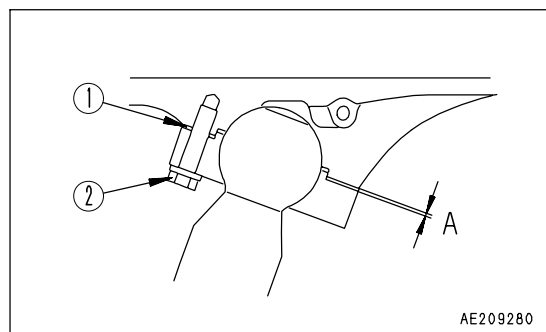

ADJUSTING RIPPER

ADJUSTING DIGGING DEPTH

Mounting pin holes are provided in the shank and these are used according to the desired digging depth. For normal use, use the bottom hole, and when particularly deep digging is needed, use the top hole.

1. Place a pointed object on the tip of pin (1), then hit with a hammer to remove from the opposite side.
2. Remove pin (2) and change the position of the shank hole.
3. Insert pin (1) partially by hand then knock it in with a hammer.
 - The pin is made of one piece, so insert it partially by hand then knock it in with a hammer.

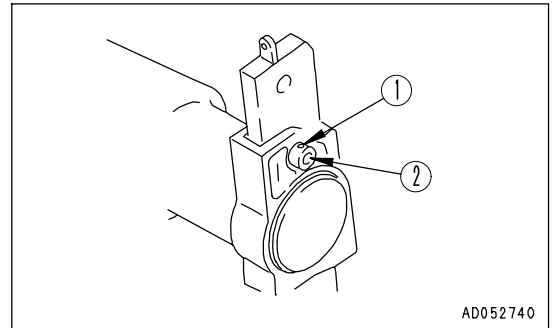

REPLACING POINT AND PROTECTOR

To protect the shank, if the protector and point installed to the tip are worn, replace them.

Place a pin remover on the pin marked by the arrow, then hit with a hammer to remove from the opposite side.

REMARK

The pin is a unitized type, so insert the pin partially by hand, then knock it in fully with a hammer.

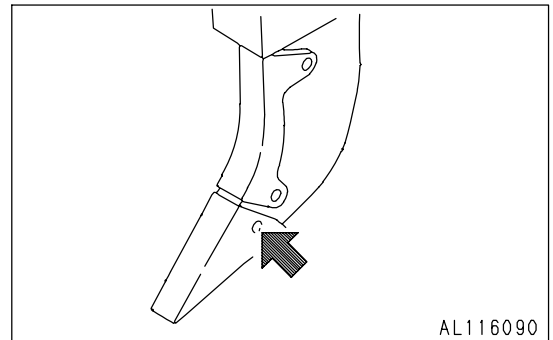

PARKING MACHINE

WARNING

- Avoid stopping suddenly. Give yourself ample room when stopping.
- When stopping the machine, select flat hard ground and avoid dangerous places. If it is unavoidably necessary to park the machine on a slope, place the parking brake lever (4) in the LOCK position and insert blocks underneath the track shoes. As an additional safety measure, thrust the blade into the ground.
- If the work equipment control lever is touched by accident, the work equipment may suddenly move, and may cause damage, serious injury, or death. Before leaving the operator's seat, always secure work equipment lock lever (7) in the LOCK position.

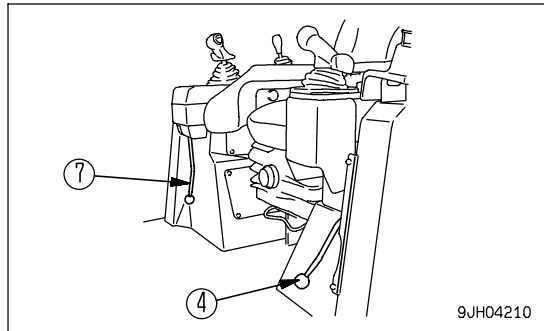
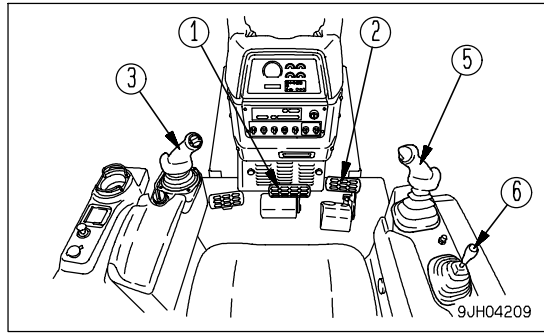

1. Depress brake pedal (1) to stop the machine.

NOTICE

If the brake pedal is depressed when the engine speed or machine travel speed is high, the brake disc may produce a slipping sound. When depressing the brake pedal, usually depress decelerator pedal (2) to reduce the engine speed and machine travel speed.

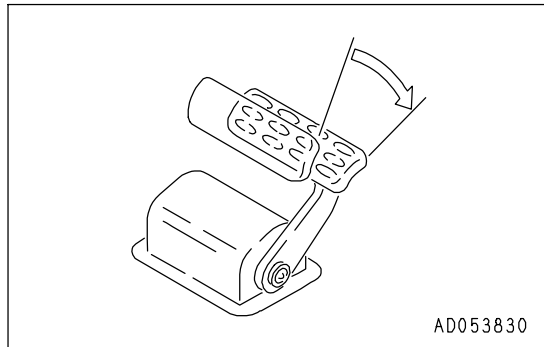

2. Place joystick (3) at the neutral position and set the speed range to 1st.

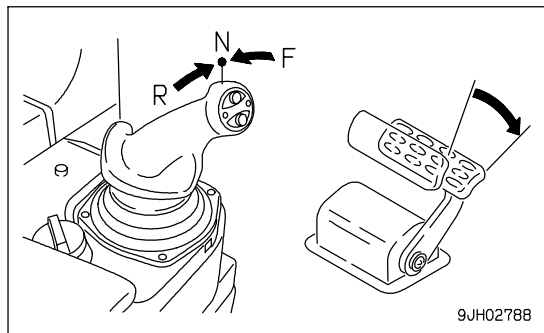

3. Set parking brake lever (4) to the LOCK position.

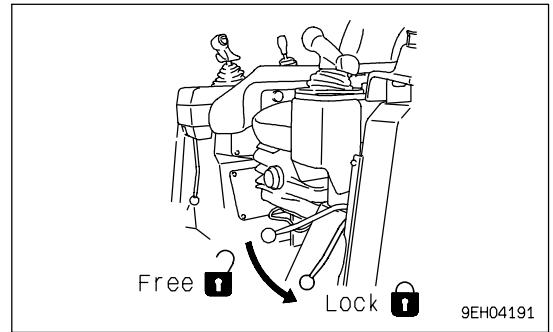

- 4. Operate blade control lever (5) and ripper control lever (6) to the LOWER position, and lower the blade and ripper to the ground.
- 5. Set blade control lever (5) and ripper control lever (6) to the HOLD position.

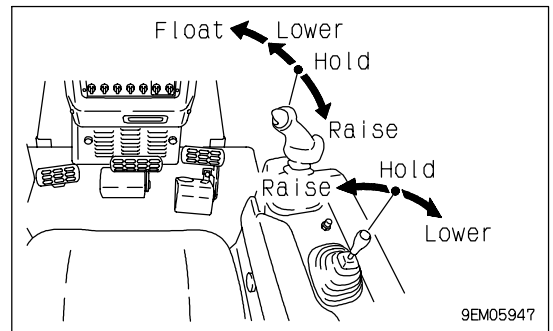

6. Set work equipment lock lever (7) for blade control lever (5) and ripper control lever (6) to the FREE position.

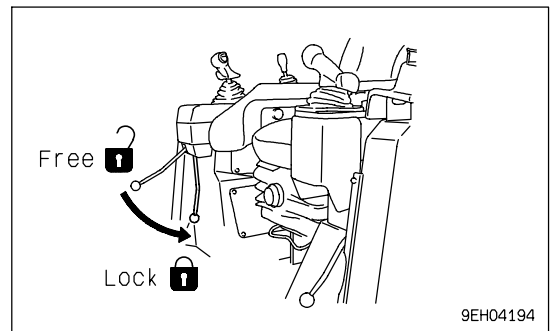

CHECK AFTER FINISHING WORK

BEFORE STOPPING ENGINE

Use the meters and caution lamps to check the engine coolant temperature, engine oil pressure, fuel, and power train oil temperature.

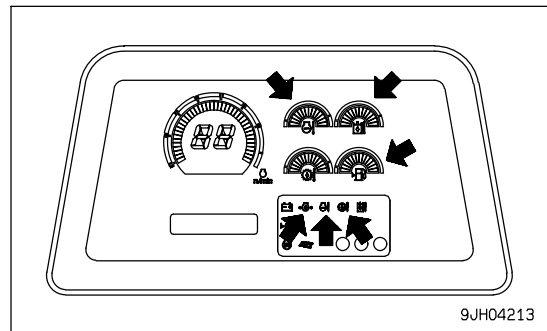

AFTER STOPPING ENGINE

1. Walk around the machine and check the work equipment, machine exterior, and undercarriage, also check for any leakage of oil or coolant. If any problems are found, repair them.
2. Fill the fuel tank.
3. Check the engine compartment for paper and debris. Clean out any paper and debris to avoid a fire hazard.
4. Remove any mud affixed to the undercarriage.

LOCKING

To prevent vandalism, there are locks in the following places.

Places that can be locked with the starting switch key.

- Right and left engine side cover (1)
(left side: 2 places, right side: 2 places)
- Cab door opener (3)
- Cap with lock (4)
 - Radiator cap (if equipped)
 - Fuel tank cap (if equipped)
 - Hydraulic oil tank cap
- Battery inspection cover (2)
- Rear cover (5)

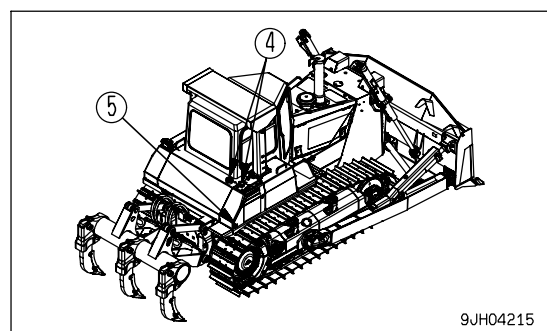
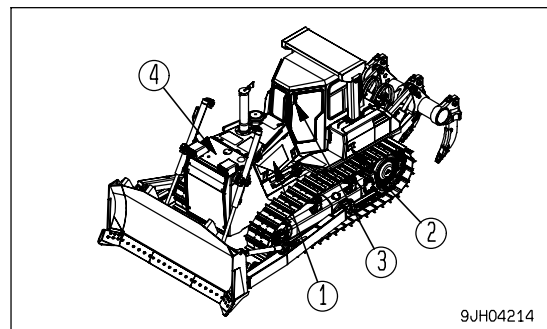

TIPS FOR LONGER UNDERCARRIAGE LIFE

Undercarriage life greatly varies depending on operation method, inspection and maintenance. For most efficient operation, keep the following point in mind.

OPERATION METHOD

- Select the track shoe that best suits the type of soil to be encountered in service.
Consult your Komatsu distributor when selecting track shoes.
- Do not allow shoe slippage to occur during operation. If slippage occurs, reduce load to the blade until slipping stops.
- Avoid sudden starts, acceleration or stops, unnecessary high speeds and sharp turns.
- Always operate machine in a straight line whenever possible. When making turns, be careful not to allow the machine to stay to one side, so operation in both turning directions can be done properly. Make turns with the largest possible radius.
- Prior to operation, clear boulders and obstacles to prevent machine from riding over them while operating.
- On a slope, operate the machine parallel to the inclination of the slope. Do not operate across the slope. Also when stopping the machine on a slope, the machine should face the top of the slope.
- When ground inclines to the left or right during digging operations, do not continue to dig with the incline. Move the machine back to level ground and start to dig again.
- Do not force the machine to carry out work that exceeds its working capability. Such work includes cases where the idler or sprocket come off the ground when the machine meets obstacles that resist the power of the machine during dozing or ripping operations.

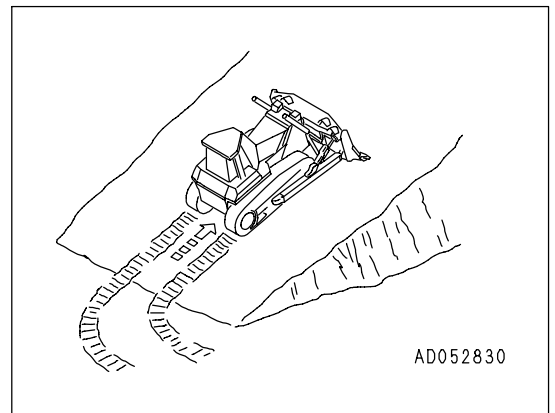

INSPECTION AND ADJUSTING

- Properly adjust track tension.
Tension should be measured at clearance (A) shown in the diagram - usually 20 to 30 mm (0.8 to 1.2 in) at this point. For rocky terrain, tighten tracks slightly. In clay or sandy areas, slightly loosen them. (For inspection and adjustment procedures, refer to "CHECK AND ADJUST TRACK TENSION (PAGE 4-28)").
- Check idler rollers for oil leakage as well as for loose bolts and nuts. If any trouble is detected, repair immediately.
- Check the clearance between the idler guide plate and the track frame. If clearance (B) increases, idler may develop side motion and tracks may come off. (For inspection and adjustment procedures, refer to "ADJUST IDLER CLEARANCE (PAGE 4-31)").

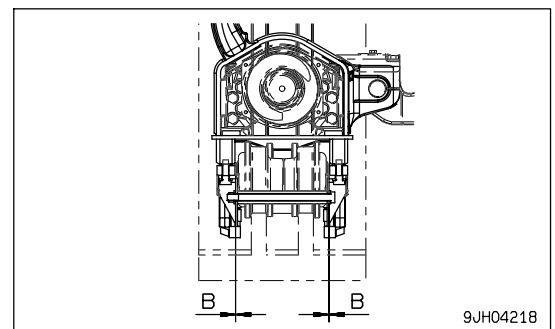
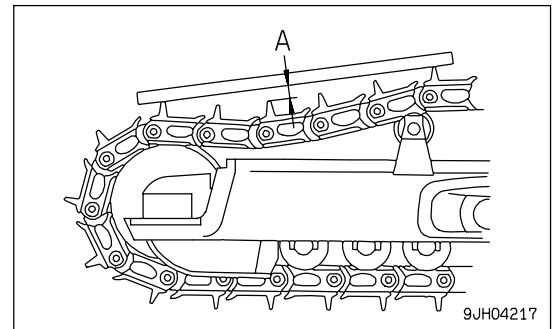

INSPECTION AND REPAIR

Frequent inspection and prompt repair will reduce repair costs.

The following items for inspection will serve as a guide to maintenance service of each undercarriage part. Perform periodical inspection and contact the Komatsu distributor in your area when machine has approached repairable limits and reversing limits.

MEASURING LINK PITCH

1. Insert a wooden block between track shoe and sprocket to take up the slack in track shoes.

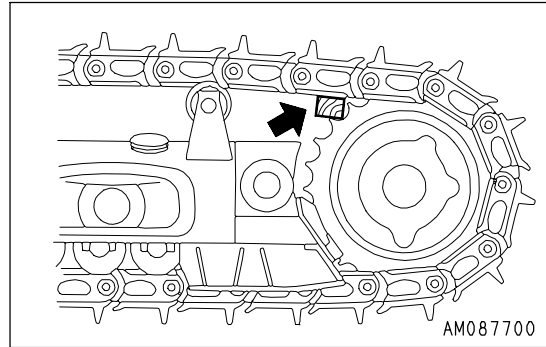

2. Measure pitch length of 4 links in stretched portion at least 2 links away for master pin. Of length obtained, 1/4 is the link pitch.

- Basic link pitch (P): 216.3 mm (8.5 in)
- Link pitch limit for turning bushing: 219.3 mm (8.6 in)

There is no link window on the master link.

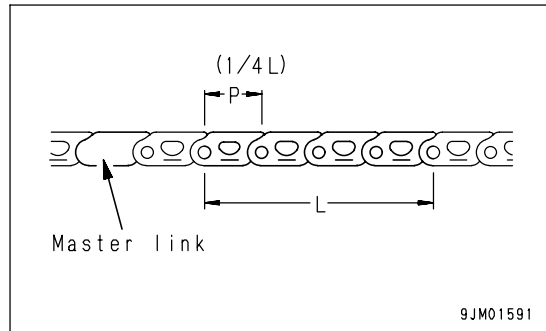

REMARK

The measured value under decimal of link pitch is different from the basic value depending upon the precision of measure or the tolerance of product even if it isn't worn out.

Don't judge it's worn out too soon, do it with the trend of measured value after that.

MEASURING HEIGHT OF GROUSER

- After taking up slack in track shoes, measure height at center of shoe as shown below.

Standard height (h): 72 mm (2.8 in)

Repair limits: 25 mm (1.0 in)

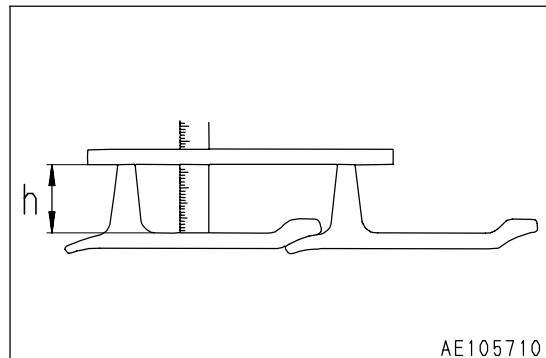

MEASURING OUTSIDE DIAMETER OF TRACK ROLLER

1. Measure height (size C) of link tread as shown.
2. Stop machine at position where link tread, whose size C has been measured completely, contacts roller tread. Then measure size B.
3. Calculate outside diameter of tread (size A)
 $A = (B - C) \times 2$
Standard size (A): 222 mm (8.7 in)
Repair limits: 182 mm (7.2 in) (Single roller)
182 mm (7.2 in) (Double roller)

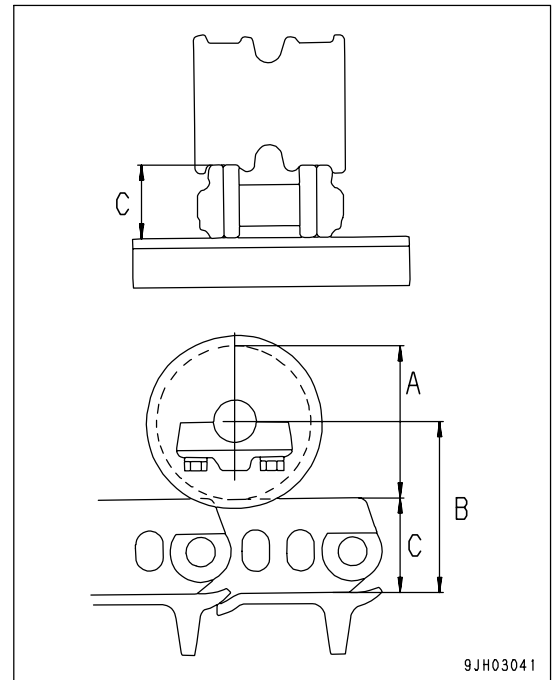

TRANSPORTATION

When transporting the machine, observe all related laws and regulations, and be careful to assure safety.

TRANSPORTATION PROCEDURE

As a rule, transport the machine on a trailer.

Select a trailer according to the mass and dimensions of the machine shown in "SPECIFICATIONS (PAGE 5-2)".

Note that the mass and dimensions for transportation shown in SPECIFICATIONS depend on the types of shoe, blade, etc.

REMOVAL OF CAB

(Machine equipped with cab) (If equipped)

If it is necessary to remove the cab for transportation, disconnect the washer hoses, cab wiring, and washer motor wiring before removing the cab.

1. Pull the grommet portion in towards the cab from the hole in the machine cover, then remove.
2. Disconnect 4 washer hoses and the wiring (single wires x 2, 4-pin plug x 1) from the socket.
 - After removing, cover the washer hoses with a vinyl bag to prevent any dirt or dust from entering.
 - Before removing the cab, measure the clearance between the cab and each lever (joystick and blade control lever, etc.). Note the measurements to use as a standard when installing the cab again.

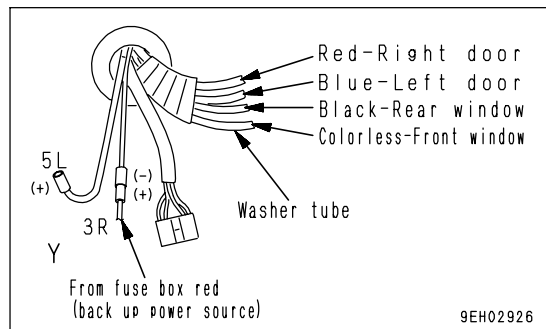
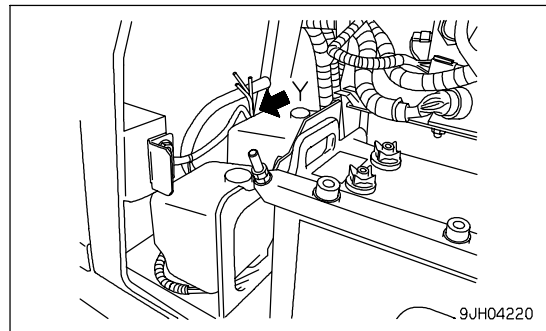

INSTALLATION OF CAB

(Machine equipped with cab) (If equipped)

Install the cab parts in the opposite order to removal.

Connect all parts that were disconnected.

1. Lower the cab slowly on top of the floor frame.
2. Align the cab with the floor frame, then install bolts and washers in holes (A) - (U).
Do not screw the bolts in fully. Screw them in 3 or 4 turns.
3. Tighten the bolts in holes (N) - (U) fully.
Tighten in the order (N), (U), (Q), (R), (O), (T), (P), (S).
4. Tighten the bolts, (A) to (M), completely.

If there are any unclear points about removing or installing the cab, please contact your Komatsu distributor.

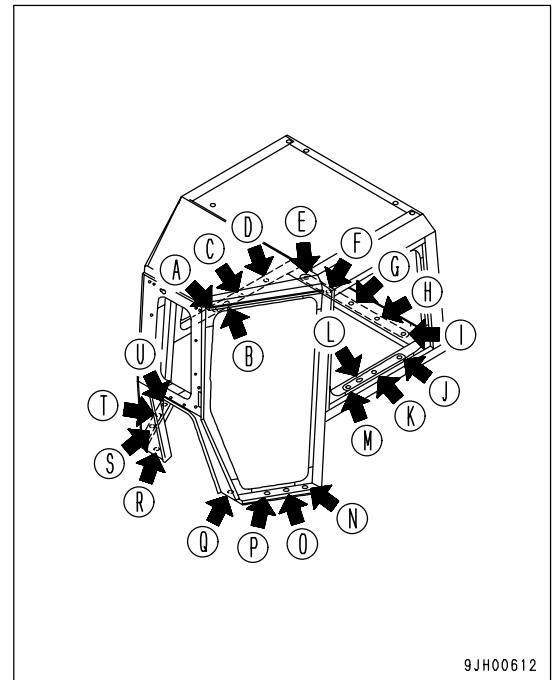

INSTALLATION OF ROPS

NOTICE

ROPS is an important component for ensuring safety. Always tighten the mounting bolts securely to the specified tightening torque.

Tightening torque: 824 - 1030 Nm (84 - 105 kgm, 607.6 - 759.5 lbft)

LOADING, UNLOADING WORK

**WARNING**

- Since loading and unloading of the machine is dangerous, be extremely careful.
- When loading or unloading the machine, operate it slowly with the engine speed low and the transmission in the 1st gear.
- Use ramps having sufficient width, length, thickness, and strength. Install them securely and set their angle to 15° or less. If the ramps are deflected appreciably, reinforce them with blocks.
- Perform the loading work of the machine on firm, level ground. Secure sufficient distance between the shoulder of the road and the trailer.
- Remove mud from the undercarriage of the machine so that the machine will not slip sideways on the ramps. In addition, remove water, snow, ice, grease, oil, etc. from the ramps.
- Never steer the machine on the ramps, since steering on the ramps can cause the machine to tip over. If it is necessary to change the travel direction, return to the ground or to the bed of the trailer, then change the travel direction.
- The center of gravity of the machine shifts suddenly at the border between the ramps and trailer, and the machine is unbalanced and becomes dangerous. Accordingly, pass the border slowly.

When loading or unloading, always use ramps or a platform. Proceed as follows.

LOADING

1. Load and unload on firm level ground only.
Maintain a safe distance from the edge of a road.
2. Properly apply the brakes on the trailer and put blocks under the tires to ensure that the trailer does not move.
Make the slope of the ramps a maximum of 15°.

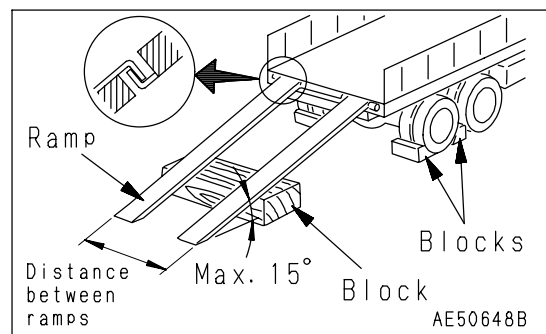

3. Start the engine.
Warm the engine up fully.
4. Set parking brake lever to the FREE position (F).
5. Set the transmission in the 1st gear and run the engine at low idle.
6. Set the travel direction toward the ramps and drive slowly.
7. The center of gravity of the machine shifts suddenly at the border between the ramps and trailer, and the machine is unbalanced and becomes dangerous. Accordingly, pass the border slowly.
8. Stop the machine at the specified position on the trailer.

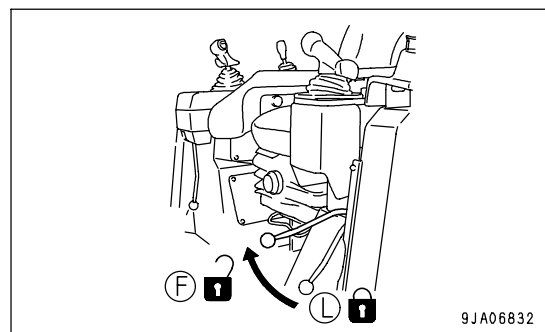

SECURING MACHINE

NOTICE

Be sure to lower the car radio antenna to the stow position (if the machine is equipped with a cab).

Load the machine onto a trailer as follows:

1. Lower the work equipment slowly.
(When transporting with work equipment installed)
2. Set the work equipment lock lever to the LOCK position (L) securely.
(When transporting with work equipment installed)

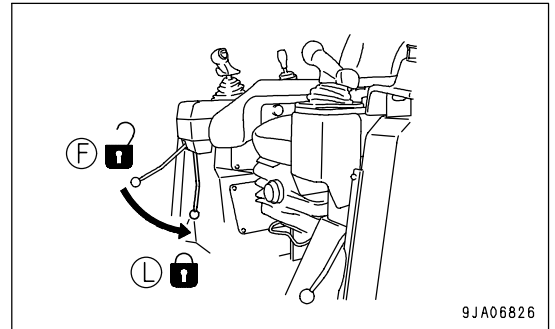

3. Set the parking brake lever to the LOCK position (L) securely.
4. Stop the engine, then remove the key from the starting switch.

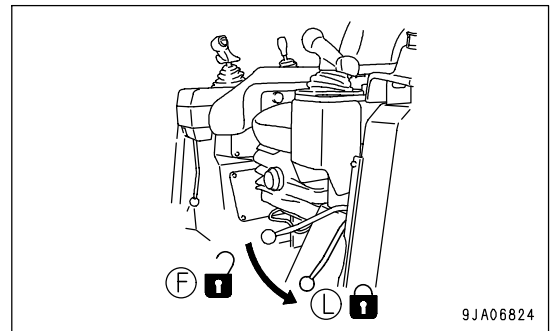

5. Fix the machine as explained below so that it will not move during transportation.

In particular, fix the machine securely to prevent it from slipping sideways.

- 1) Put blocks (1) in front and behind the track shoes of both sides.
- 2) Set up chain or wire, following (A) or (B).
 - A: Secure chain or wire around the track shoes.
 - B: Secure chain or wire through the holes of track links.
- 3) Protect the wire from contacting directly with angular parts of the machine, by inserting pads.

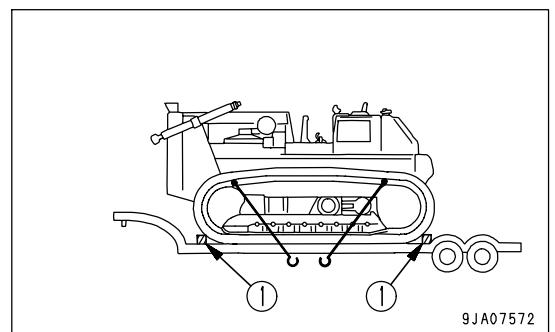
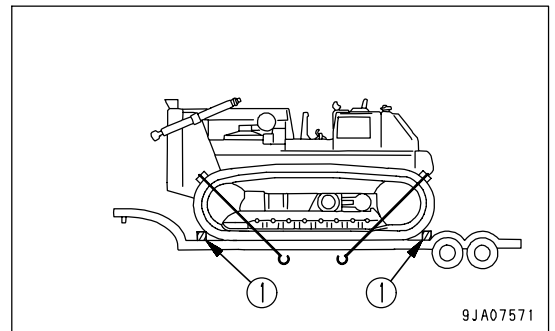

- 4) Secure the attachment at two places with a chain or wire rope.

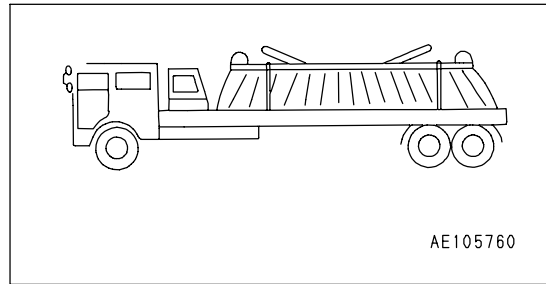

UNLOADING

1. Load and unload on firm level ground only. Maintain a safe distance from the edge of a road.
2. Properly apply the brakes on the trailer and put blocks under the tires to ensure that the trailer does not move. Make the slope of the ramps a maximum of 15°.
3. Remove the chains and wire ropes fastening the machine.

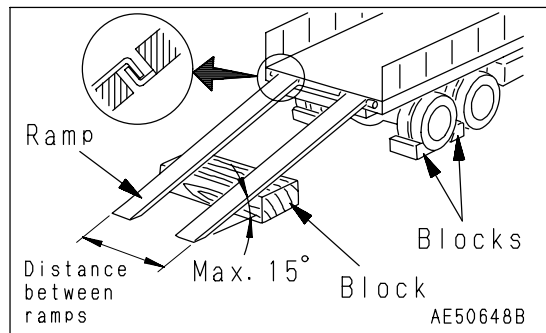

4. Start the engine.
Warm the engine up fully.
5. Set main work equipment lock lever to FREE position (F), and raise the work equipment.
(When transporting with work equipment installed)

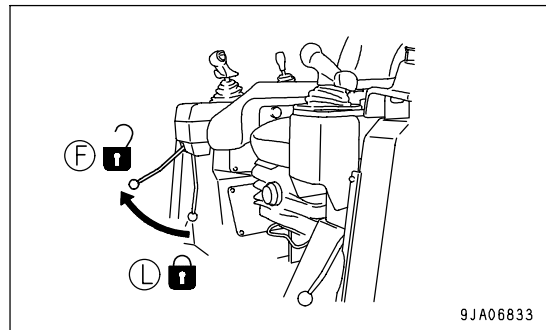

6. Set parking brake lever to the FREE position (F).
7. Set the transmission in the 1st gear and run the engine at low idle.
8. Set the travel direction toward the ramps and drive slowly.
9. The center of gravity of the machine shifts suddenly at the border between the ramps and trailer, and the machine is unbalanced and becomes dangerous. Accordingly, pass the border slowly.
10. Drive down the ramps slowly and carefully until the machine leaves the ramps perfectly.

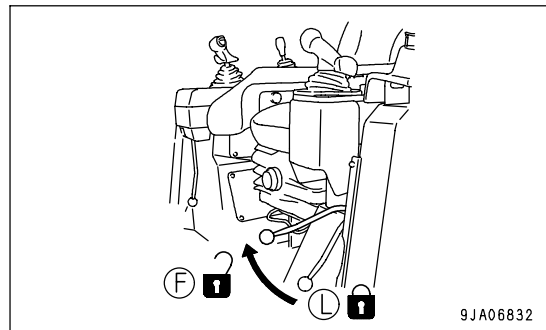

METHOD OF LIFTING MACHINE

**WARNING**

- The person using the crane to carry out lifting operations must be a qualified crane operator.
- Never carry out lifting operations if any person is on the machine being lifted.
- Always use a wire rope that has ample strength for the weight of the machine being lifted.
- Keep the machine horizontal when lifting it.
- When carrying out lifting operations, set the work equipment lock lever and parking brake lever to the LOCK position to prevent the machine or work equipment from moving unexpectedly.
- Never enter the area under or around a raised machine.
- There is danger of the machine losing its balance.

Use the procedure below to set the machine in the proper posture and use the lifting equipment when lifting the machine.

NOTICE

This method of lifting applies to the standard specification machine.

The method of lifting differs according to the attachments and options installed.

For details of the procedure for machines that are not the standard specification, please consult your Komatsu distributor.

For weight, see "SPECIFICATIONS (PAGE 5-2)".

When lifting the machine, stop it on a level place, then observe the following procedure.

1. Stop the engine and set the parking brake lever to the LOCK position (L) securely.

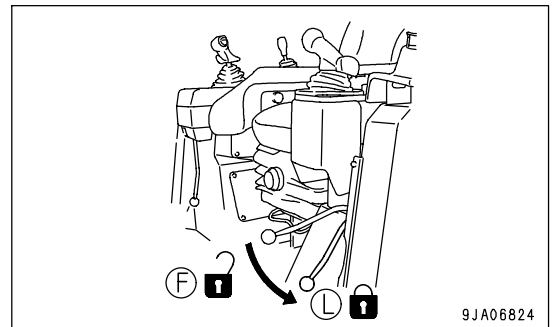

2. Set the work equipment lock lever to the LOCK position (L) securely.

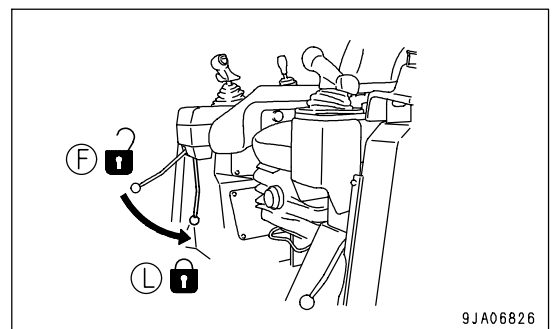

3. Install wire ropes, slings, etc. matched to the weight of the machine to the lifting points as shown in the diagram on the right.

NOTICE

- Use protectors to prevent the wire rope from being cut on sharp corners and to prevent the wire rope from cutting into the machine bodywork.
- When using a spreader bar, select an ample width to prevent contact with the machine.

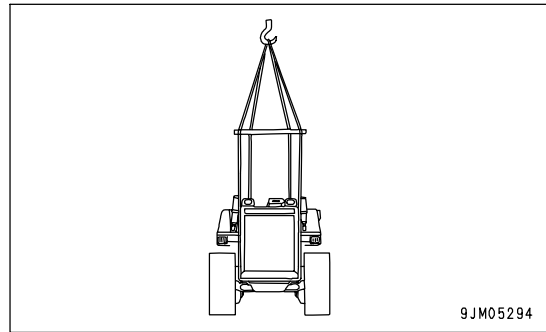

4. After setting the wire ropes, lift up the machine and stop at 100 to 200 mm (3.9 to 7.9 in) above the ground, and check that the wire ropes are not slack and the machine is level, then lift up slowly.

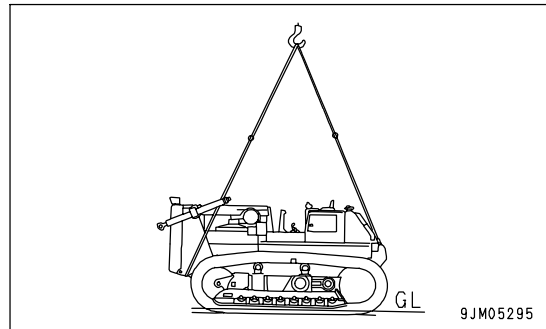
**PRECAUTIONS FOR TRANSPORTATION****WARNING**

Determine the route for transporting the machine by taking into account the width, height and weight of the machine.

Obey all state and local laws governing the weight, width and length of a load. Observe all regulations governing wide loads.

TRAVELING ON ROADS

- When traveling on paved roads, use flat shoes to protect their surface.
Even when travelling a short distance, always place boards to protect the road surface.

REMARK

Note that the asphalt road becomes soft in summer.

COLD WEATHER OPERATION

PRECAUTIONS FOR LOW TEMPERATURE

If the temperature becomes low, it becomes difficult to start the engine, and the coolant may freeze, so do as follows.

FUEL AND LUBRICANTS

Change to oil with low viscosity for all components. For details of the specified viscosity, see "RECOMMENDED FUEL, COOLANT, AND LUBRICANT (PAGE 4-10)".

COOLANT



WARNING

- Antifreeze is toxic. Be careful not to get it into your eyes or on your skin. If it should get into your eyes or on your skin, wash it off with large amounts of fresh water and see a doctor at once.
- When changing the coolant or when handling coolant containing antifreeze that has been drained when repairing the radiator, please contact your Komatsu distributor or request a specialist company to carry out the operation. Antifreeze is toxic. Do not let it flow into drainage ditches or spray it onto the ground surface.
- Antifreeze is flammable. Do not bring any flame close. Do not smoke when handling antifreeze.

NOTICE

Please use Komatsu genuine supercoolant (AF-NAC) for the coolant. As a basic rule, we do not recommend the use of any coolant other than Komatsu genuine supercoolant.

For details on the amount of antifreeze mixture and on when to change the coolant, see "CLEAN INSIDE OF COOLING SYSTEM (PAGE 4-20)".

BATTERY



WARNING

- The battery generates flammable gas. Do not bring fire or sparks near the battery.
- Battery electrolyte is dangerous. If it gets in your eyes or on your skin, wash it off with a large amount of water and consult a doctor.
- Battery electrolyte dissolves paint. If it gets on the bodywork, wash it off immediately with water.
- If the battery electrolyte is frozen, do not charge the battery or start the engine with a different power source. There is danger that the battery may explode.
- Battery electrolyte is toxic. Do not let it flow into drainage ditches or spray it on to the ground surface.

When the ambient temperature drops, the capacity of the battery will also drop. If the battery charge ratio is low, the battery electrolyte may freeze. Maintain the battery charge as close as possible to 100%. Insulate it against cold temperature to ensure the machine can be started easily the next morning.

REMARK

Measure the specific gravity and calculate the charging rate from the following conversion table.

Charging Rate (%)	Electrolyte Temperature	20°C (68°F)	0°C (32°F)	-10°C (14°F)	-20°C (-4°F)
	100		1.28	1.29	1.30
90		1.26	1.27	1.28	1.29
80		1.24	1.25	1.26	1.27
75		1.23	1.24	1.25	1.26

- As the battery capacity drastically drops in low temperatures, cover or remove the battery from the machine, store the battery in a warm place, and install it again the next morning.
- If the electrolyte level is low, add distilled water in the morning before beginning work. Do not add water after the day's work to prevent diluted electrolyte in the battery from freezing during the night.

AFTER COMPLETION OF WORK

To prevent mud, water, or the undercarriage from freezing and making it impossible for the machine to move on the following morning, observe the following precautions.

- Remove all the mud and water from the machine body. In particular, wipe the hydraulic cylinder rods clean to prevent damage to the seal caused by mud, dirt, or drops of water on the rod from getting inside the seal.
- Park the machine on hard, dry ground.

If this is impossible, park the machine on boards.

The boards prevent the tracks from freezing to the ground, and allow the machine to be moved the next morning.

- Open the drain valve and drain any water collected in the fuel system to prevent it from freezing.
- Fill the fuel tank to capacity. This minimizes moisture condensation in the tank when the temperature drops.

AFTER COLD WEATHER

When the season changes and the weather becomes warmer, do as follows.

- Replace the fuel and oil for all parts with oil of the viscosity specified.

For details, see "RECOMMENDED FUEL, COOLANT, AND LUBRICANT (PAGE 4-10)".

LONG-TERM STORAGE

BEFORE STORAGE

When keeping in long-term storage (more than one month), store as follows.

- Clean and wash all parts, then store the machine indoors. If the machine has to be stored outdoors, select level ground and cover the machine with a sheet.
- Completely fill the fuel tank. This prevents moisture from collecting.
- Lubricate and change the oil before storage.
- Apply a thin coat of grease to metal surface of the hydraulic piston rods and the idler adjusting rods.
- Disconnect the negative terminals of the battery and cover it or remove it from the machine and store it separately.
- Place all control levers in the neutral position, set the work equipment lock lever and parking brake lever in the LOCK position, and set the fuel control dial to the low idling position.
- To prevent rust, fill with Komatsu genuine supercoolant (AF-NAC) to give a density of at least 30% for the engine coolant.

DURING STORAGE



WARNING

If it is necessary to perform the rust-prevention operation while the machine is indoors, open the doors and windows to improve ventilation and prevent gas poisoning.

- During storage, operate and move the machine for a short distance once a month so that a new film of oil will coat moving parts. At the same time, also charge the battery.
- Before operating the work equipment, wipe the grease off the hydraulic piston rod.
- If the machine is equipped with an air conditioner, operate the air conditioner for 3 to 5 minutes once a month to lubricate all parts of the air conditioner compressor. Always run the engine at low idle when doing this. In addition, check the refrigerant level twice a year.

AFTER STORAGE

NOTICE

If the machine has been stored without carrying out the monthly rust-prevention operation, consult your Komatsu distributor before using it.

When using the machine after long-term storage, do as follows before using it.

- Wipe off the grease from the hydraulic cylinder rods.
- Add oil and grease at all lubrication points.
- When the machine is stored for a long period, moisture in the air will mix with the oil. Check the oil before and after starting the engine. If there is water in the oil, change all the oil.

TROUBLESHOOTING

AFTER RUNNING OUT OF FUEL

When starting the engine again after running out of fuel, fill with fuel, then bleed the air from the fuel system before starting the engine.

Always watch the fuel level and be careful not to run out of fuel.

If the engine has stopped because of lack of fuel, it is necessary to use the priming pump to bleed the air completely from the fuel circuit.

PROCEDURE FOR BLEEDING AIR



CAUTION

- This engine consists of higher precision parts than on the conventional fuel injection pump and nozzle, so if dirt gets in, it will cause problems. If there is any dirt stuck to the fuel line, use fuel to wash it off completely.
- Be careful when opening the air bleed plug at the fuel filter head and the air bleeder of the supply pump. The system is still under pressure and fuel may spurt out.

1. Fill the fuel tank with fuel.
2. Loosen air bleed plug (A), (B) at the fuel filter head (1).
3. Loosen the knob of priming pump (2), then pump the knob until no more bubbles come out of air bleed plug (A).
4. Wrap sealing tape around air bleed plug (A) before tightening it.
5. Operate the priming pump again and check that no more bubbles come out with the fuel from air bleed plug (B).
6. Tighten air bleed plug (B).
Tightening torque: 4.9 to 6.9 Nm (0.5 to 0.7 kgm , 3.6 to 5.1 lbft)
7. Loosen air bleeder (3) of the supply pump.
8. Pump priming pump (2) approx. 90 - 100 times until no more bubbles come out with the fuel from air bleeder (3), then tighten air bleeder (3).
Tightening torque: 4.9 to 6.9 Nm (0.5 to 0.7 kgm , 3.6 to 5.1 lbft)
9. Continue pumping (approx. 50 times) until the priming pump (2) becomes stiff and the overflow valve release sound becomes continuous.
10. Push in the knob of priming pump (2) and tighten it.

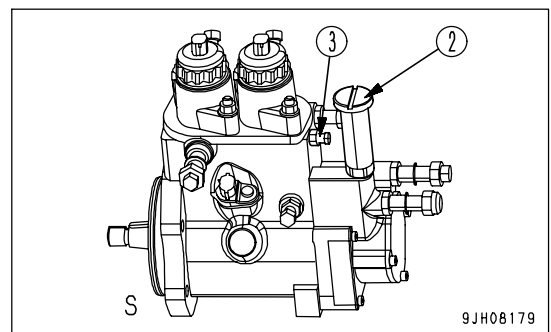
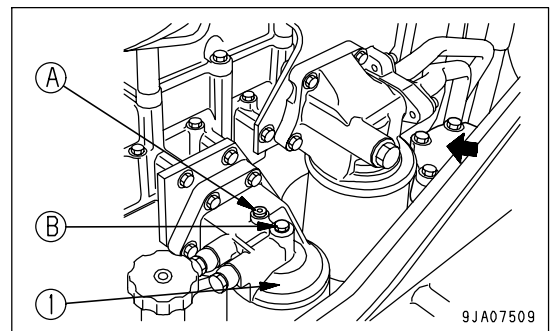

11. Turn the key in the starting switch to the START position and start the engine.
When doing this, do not crank the starting motor continuously for more than 20 seconds. If the engine does not start, wait for at least 2 minutes, then try again. Perform this operation a maximum of 4 times.
12. If the engine does not start, repeat the procedure from Step 2.

METHOD OF TOWING MACHINE



WARNING

Serious injury or death could result if a disabled machine is towed incorrectly or if there is a mistake in the selection or inspection of the wire rope.

- If the engine does not start, put blocks under the track to prevent the machine from moving, then release the brake. If blocks are not use, there is danger that the machine may move suddenly.
- Always check that the wire rope used for towing has ample strength for the weight of the machine being towed.
- Never use a wire rope which has cut strands (A), reduced diameter (B), or kinks (C). There is danger that the rope may break during the towing operation.
- Always wear leather gloves when handling wire rope.
- Never tow a machine on a slope.
- During the towing operation, never stand between the towing machine and the machine being towed.
- Operate the machine slowly and be careful not to apply any sudden load to the wire rope.

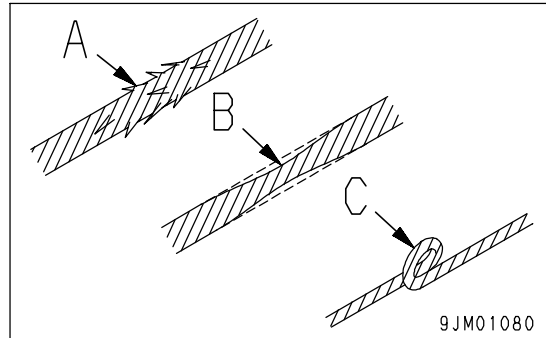

NOTICE

The maximum towing capacity for this machine is 205,800 N (21,000 kg).
Always carry out towing operations within the maximum towing capacity.

For details of the method of towing, please contact your Komatsu distributor.

- If the engine stops or the oil pressure in the brake circuit lowers because of a trouble in the hydraulic system, the brake works and the machine cannot move. To move the machine in this case, the oil pressure in the brake circuit must be heightened to the specified level with a special device. Ask your Komatsu distributor.
- Moving a machine by towing is only used to move it to a place where it is possible to carry out inspection and maintenance. It is not intended for moving the machine long distances. Do not use this method for towing the machine for long distances.
- If it is impossible to operate the steering and brakes of the machine being towed, do not let anyone ride on the machine.
- Keep the angle of the towing line to the minimum. Operate the machine so that the angle does not become greater than 30° from the straight line.

If the machine sinks in mud and cannot get out under its own power, or if being used to tow a heavy object, fit the wire to the towing hook as shown in the diagram on the right, or in the case of machines with a drawbar, fit the wire to the drawbar pin when towing.

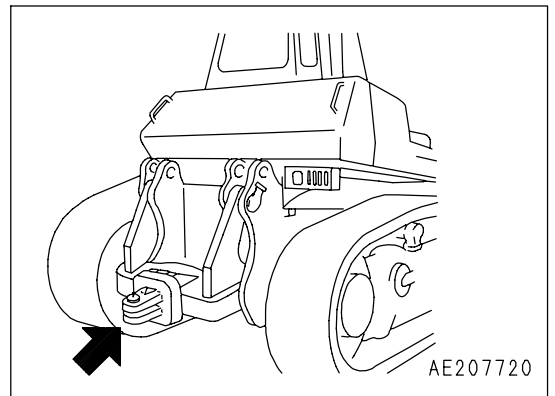
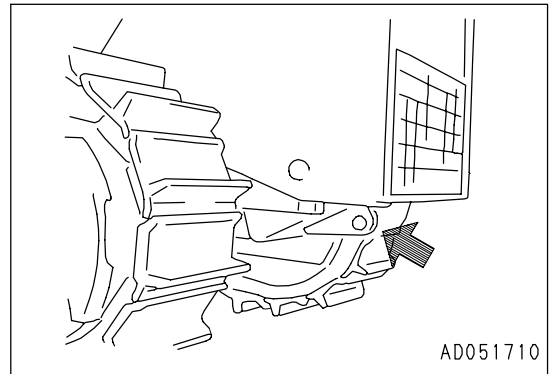

IF BATTERY IS DISCHARGED



WARNING

- It is dangerous to charge a battery when mounted on a machine. Make sure that it is dismantled before charging.
- When checking or handling the battery, stop the engine and turn the starting switch key to the OFF position.
- The battery generates hydrogen gas, so there is a hazard of explosion. Do not bring lighted cigarettes near the battery, or do anything that will cause sparks.
- Battery electrolyte is dilute sulfuric acid, and it will attack your clothes and skin. If it gets on your clothes or on your skin, immediately wash it off with a large amount of water. If it gets in your eyes, wash it out with fresh water and consult a doctor.
- When handling batteries, always wear safety glasses and rubber gloves.
- When removing the battery, first disconnect the cable from the ground (normally the negative (-) terminal). When installing, install the positive (+) terminal first.
If a tool touches the positive terminal and the chassis, there is danger that it will cause a spark, so be extremely careful.
- If the terminals are loose, there is danger that the defective contact may generate sparks that will cause an explosion.
- When removing or installing the terminals, check which is the positive (+) terminal and which is the negative (-) terminal.

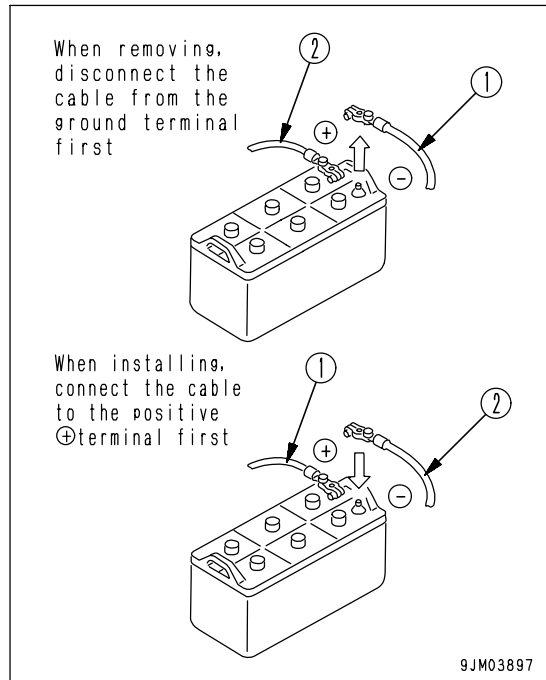

9JM03897

REMOVAL AND INSTALLATION OF BATTERY

- Before removing the battery, remove the ground cable (normally connected to the negative (-) terminal).
If any tool touches between the positive terminal and the chassis, there is a hazard of sparks being generated.
- When installing the battery, connect the ground cable last.
- When replacing the battery, secure it with battery hold-down.
Tightening torque: Tightening battery terminal: 9.8 to 14.7 Nm (1 to 1.5 kgm, 7.2 to 10.8 lbf)

REMOVAL, INSTALLATION OF BATTERY CABLE

1. Open the battery cover (1).
2. Before removing the battery, remove the ground cable (normally connected to the negative (-) terminal). If any tool touches between the positive terminal and the chassis, there is danger of sparks being generated. Loosen the nut of the terminal and remove the wires from the battery.
3. When installing the battery, connect the ground cable last.
Insert the hole of the terminal on the battery and tighten the nut.
Tightening torque: 9.8 to 19.6 Nm (1 to 2 kgm, 7.2 to 14.5 lbf)
4. Close the cover.

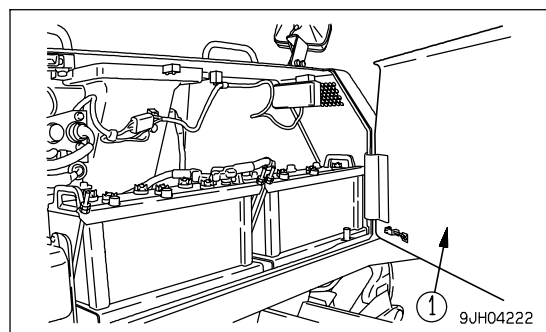

9JH04222

PRECAUTIONS WHEN CHARGING BATTERY

When charging the battery, if the battery is mistakenly handled, there is danger of explosion. Follow the precautions in "IF BATTERY IS DISCHARGED (PAGE 3-144)" and the instructions given in the charger manual, and always do as follows.

- Set the voltage of the charger to match the voltage of the battery to be charged. If the correct voltage is not selected, the charger may overheat and cause an explosion.
- Connect the positive (+) charger clip of the charger to the positive (+) terminal of the battery, then connect the negative (-) charger clip of the charger to the negative (-) terminal of the battery. Be sure to attach the clips securely.
- Set the charging current to 1/10 of the value of the rated battery capacity; when carrying out rapid charging, set it to less than the rated battery capacity.
If the charger current is too high, the electrolyte will leak or dry up, and this may cause the battery to catch fire and explode.
- If the battery electrolyte is frozen, do not charge the battery or start the engine with a different power source. There is a danger that this will ignite the battery electrolyte and cause the battery to explode.
- Do not use or charge the battery if the battery electrolyte level is below the LOWER LEVEL line. This may cause an explosion. Check the battery electrolyte level periodically and add distilled water to bring the electrolyte level to the UPPER LEVEL line.

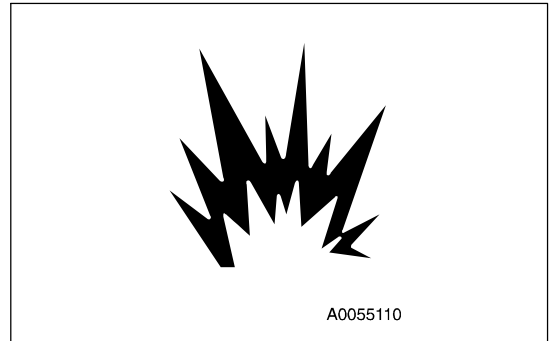

STARTING ENGINE WITH BOOSTER CABLE

When starting the engine with a booster cable, do as follows.

PRECAUTIONS WHEN CONNECTING AND DISCONNECTING BOOSTER CABLE



WARNING

- When connecting the cables, never contact the positive (+) and negative (-) terminals.
- When starting the engine with a booster cable, wear safety glasses and rubber gloves.
- Be careful not to let the normal machine and problem machine contact each other. This prevents sparks from generating near the battery which could ignite the hydrogen gas given off by the battery.
- Make sure that there is no mistake in the booster cable connections. The final connection is to the engine block of the problem machine, but sparks will be generated when this is done, so connect to a place as far as possible from the battery.
- When disconnecting the booster cable, take care not to bring the clips in contact with each other or with the machine body.

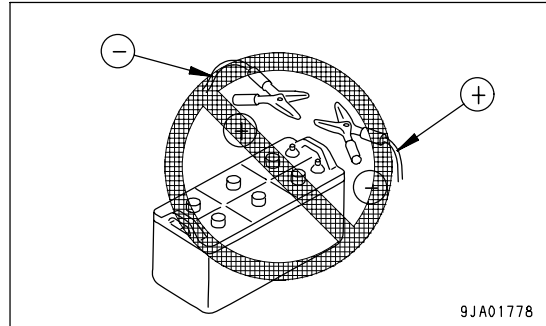

9JA01778

NOTICE

- The starting system for this machine uses 24V. For the normal machine, also use a 24V battery.
- The size of the booster cable and clip should be suitable for the battery size.
- The battery of the normal machine must be the same capacity as that of the engine to be started.
- Check the cables and clips for damage or corrosion.
- Make sure that the cables and clips are firmly connected.
- Check that the work equipment lock levers and parking brake levers of both machine are in the LOCK position.
- Check that each lever is in the NEUTRAL position.

CONNECTING THE BOOSTER CABLES

Keep the starting switch of the normal machine and problem machine in the OFF position.

Connect the booster cable as follows, in the order of the numbers marked in the diagram.

1. Connect one clip of booster cable (A) to the positive (+) terminal of the problem machine.
2. Connect the other clip of booster cable (A) to the positive (+) terminal of the normal machine.
3. Connect one clip of booster cable (B) to the negative (-) terminal of the normal machine.
4. Connect the other clip of booster cable (B) to the engine block of the problem machine.

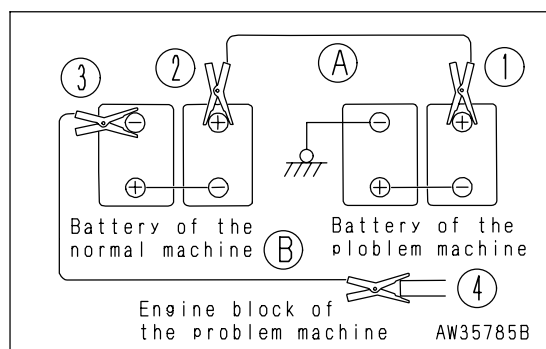

STARTING THE ENGINE

**WARNING**

Always check that the work equipment lock lever and Parking brake lever is set to the LOCK position, regardless of whether the machine is working normally or has failed. Check also that all the control levers are in the HOLD or NEUTRAL position.

1. Make sure the clips are firmly connected to the battery terminals.
 2. Start engine of the normal machine and run it at high idle speed.
 3. Turn the starting switch of the problem machine to the START position and start the engine.
- If the engine doesn't start at first, try again after 2 minutes or so.

DISCONNECTING THE BOOSTER CABLES

After the engine has started, disconnect the booster cables in the reverse of the order in which they were connected.

1. Remove one clip of booster cable (B) from the engine block of the problem machine.
2. Remove the other clip of booster cable (B) from the negative (-) terminal of the normal machine.
3. Remove one clip of booster cable (A) from the positive (+) terminal of the normal machine.
4. Remove the other clip of booster cable (A) from the positive (+) terminal of the problem machine.

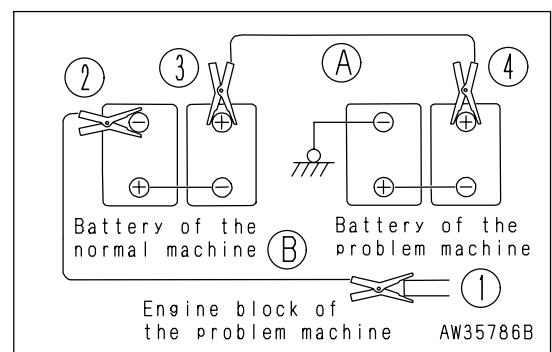

OTHER TROUBLE

ELECTRICAL SYSTEM

- (): Always contact your Komatsu distributor when dealing with these items.
- In cases of problems or causes which are not listed below, contact your Komatsu distributor for repairs.

Problem	Main cause	Remedy
Lamp does not glow brightly even when the engine runs at high speed	• Defective wiring	(• Check, repair loose terminals, disconnections Check fuses and diodes in fuse box)
Lamp flickers while engine is running	• Defective adjustment of fan belt tension	• Adjust fan belt tension For details, see EVERY 250 HOURS SERVICE
Charge lamp does not go out even when engine is running	• Defective alternator • Defective wiring	(• Replace) (• Check, repair Check fuse, diode in fuse box)
Abnormal noise is generated from alternator	• Defective alternator	(• Replace)
Starting motor does not turn when starting switch is turned to ON	• Defective wiring • Insufficient battery charge	(• Check, repair) • Charge
Pinion of starting motor keeps going in and out	• Insufficient battery charge	• Charge
Starting motor turns engine sluggishly	• Insufficient battery charge • Defective starting motor	• Charge (• Replace)
Starting motor disengages before engine starts	• Defective wiring • Insufficient battery charge	(• Check, repair) • Charge
Preheating monitor lamp does not light up (When the temperature of the engine cooling water exceed 20°C (68°F), this condition is normal)	• Defective wiring • Defective timer • Defective monitor • Disconnection in glow plug	(• Check, repair) (• Replace) (• Replace) (• Replace)
Air conditioner operation is defective	• Blown fuse • Insufficient battery charge • Defective air conditioner switch • Defective blower switch • Defective compressor	(• Check, repair) • Charge (• Replace air conditioner switch) (• Replace blower switch) (• Replace)

MONITOR PANEL

When an error code appears on the display panel B (multi-information), take appropriate remedies based upon the table below.

- (1): Display panel B
- (2): Warning lamp (red)

REMARK

If different kinds of failures occur at the same time, their failure codes are arranged in the order of seriousness in the display. The order of seriousness in this case is E04, E03, E02 and E01, starting from the most serious one.

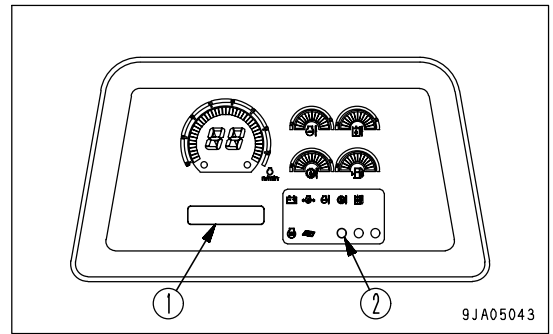

Error code	Abnormality	Method of displaying abnormality	Remedy
E01	<ul style="list-style-type: none"> • Backup alarm does not sound • Fan rotation is too fast 	Displays in turn with service meter	Automatic functions stop, some functions stop, but operation is possible. Please contact your Komatsu distributor for repairs.
E02	<ul style="list-style-type: none"> • Tilt limit does not work • Does not shift up or shift down • Pitch does not work 	Abnormality code and service hour are displayed in turn on service meter portion, caution lamp flashes, buzzer sounds	If user stops engine and then starts again, operations are possible without limit functions. However, user must be careful. Please contact your Komatsu distributor immediately for repairs.
E03+CALL	<ul style="list-style-type: none"> • Number of speed ranges that can be used is limited • Engine does not run at full speed • Excessive shock when shifting gear • Turning ability becomes poor • Excessive braking shock • Abnormality in engine water temperature sensor 	Abnormality code and service hour are displayed in turn on service meter portion, caution lamp flashes, buzzer sounds	Move machine to a safe place, then contact your Komatsu distributor immediately for repairs.
E04+CALL	<ul style="list-style-type: none"> • Engine control impossible • Travel impossible • Machine does not stop 	Abnormality code and service hour are displayed in turn on service meter portion, caution lamp flashes, buzzer sounds	Stop machine, then contact your Komatsu distributor immediately for repairs.

Note: If a problem display appears on display panel B, check the fault code. For details, see "METHOD OF USING FAULT CODE DISPLAY MODE (PAGE 3-30)".

When contacting your Komatsu distributor, please give the fault code also.

CHASSIS

- (): Always contact your Komatsu distributor when dealing with these items.
- In cases of problems or causes which are not listed below, contact your Komatsu distributor for repairs.

Problem	Main causes	Remedy
Oil pressure in torque converter fails to rise	<ul style="list-style-type: none"> • Improper tightening of oil pipe, pipe joint, air leaking in or oil leaking out because of damage • Wear, scuffing of gear pump • Insufficient oil in power train case • Clogged oil filter element strainer in power train case 	<ul style="list-style-type: none"> • Check, repair (• Check, replace) • Add oil to the specified level. For details, see CHECK BEFORE STARTING • Clean. For details, see EVERY 500 HOURS SERVICE
Torque converter is overheats	<ul style="list-style-type: none"> • Clogged radiator • Engine water temperature is high • Clogged oil cooler • Oil pressure too low • Lack of flow of lubricant caused by wear of power train gear pump 	<ul style="list-style-type: none"> • Clean radiator core • See ENGINE related parts (• Clean or replace) • Go to "Oil pressure in torque converter fails to rise" (• Replace gear pump)
Torque converter oil temperature gauge dose not work	<ul style="list-style-type: none"> • Defective oil temperature gauge • defective contact in wiring connection 	<ul style="list-style-type: none"> (• Replace oil temperature gauge) (• Check, repair)
Lacks drawber pull (machine dose not pick up speed)	<ul style="list-style-type: none"> • Lack of engine horsepower • Oil pressure in torque converter is too low 	<ul style="list-style-type: none"> • See ENGINE related parts • Go to " Oil pressure in torque converter fails to rise"
Machine will not move off when joystick is placed at FORWARD	<ul style="list-style-type: none"> • Insufficient oil in power train case • Transmission oil pressure does not rise • Defective lever wiring • Parking brake lever is at LOCK position 	<ul style="list-style-type: none"> • Add oil to specified level. For details, see CHECK BEFORE STARTING • Go to oil pressure in torque converter fails to rise (• Check, repair) • Set to FREE position
Dose not steer even when steering is operated	<ul style="list-style-type: none"> • Brake is not applied on side which is pulled • Parking brake lever is at LOCK position • Defective lever wiring • Abnormality HSS pump • Abnormality HSS motor 	<ul style="list-style-type: none"> (• Adjust linkage. Check brake pressure) • Set to FREE position (• Check, repair) (• Check, replace) (• Check, replace)
Machine doesn't stop when brake pedal are depressed	<ul style="list-style-type: none"> • Defective brake adjustment 	<ul style="list-style-type: none"> (• Adjust linkage) (• Check brake pressure)
Track comes off	<ul style="list-style-type: none"> • Track is too loose 	<ul style="list-style-type: none"> • Adjust track tension. For details, see WHEN REQUIRED
Sprocket develops abnormal wear	<ul style="list-style-type: none"> • Track is too loose or too tight 	<ul style="list-style-type: none"> • Adjust track tension. For details, see WHEN REQUIRED
Machine does not travel in straight line	<ul style="list-style-type: none"> • Defective adjustment of HSS controller • Abnormality HSS pump 	<ul style="list-style-type: none"> (• Adjust) (• Replace)

Problem	Main causes	Remedy
blade rises too slowly or dose not rise at all (or blade tilts too slowly)	<ul style="list-style-type: none"> • Lack of hydraulic oil • Defective hydraulic pump • Work equipment lock lever is at LOCK position 	<ul style="list-style-type: none"> • Add oil to specified level. For details, see EVERY 250 HOURS SERVICE • Check • Set to FREE position
Ripper moves too slowly, does not move	<ul style="list-style-type: none"> • Lack of hydraulic oil • Defective hydraulic pump • Work equipment lock lever is at LOCK position 	<ul style="list-style-type: none"> • Add oil to specified level. For details, see EVERY 250 HOURS SERVICE • Check • Set to FREE position
Insufficient force of ripper	<ul style="list-style-type: none"> • Leakage from piping 	<ul style="list-style-type: none"> (• Tighten)

ENGINE

- (): Always contact your Komatsu distributor when dealing with these items.
- In cases of problems or causes which are not listed below, contact your Komatsu distributor for repairs.

Problem	Main causes	Remedy
Engine oil pressure monitor flashes when engine speed is raised after completion of warm-up	<ul style="list-style-type: none"> • Engine oil pan oil level is low (sucking in air) • Clogged oil filter cartridge • Defective tightening of oil pipe joint, oil leakage from damaged part • Defective monitor panel 	<ul style="list-style-type: none"> • Add oil to specified level, see CHECK BEFORE STARTING • Replace cartridge, see EVERY 500 HOURS SERVICE (• Check, repair) (• Replace)
Steam is emitted from top part of radiator (pressure valve)	<ul style="list-style-type: none"> • Coolant level low, water leakage • Dirt or scale accumulated in cooling system 	<ul style="list-style-type: none"> • Add coolant, repair, see CHECK BEFORE STARTING • Change coolant, clean inside of cooling system, see WHEN REQUIRED • Clean or repair, see WHEN REQUIRED (• Replace thermostat) • Tighten cap or replace packing
Engine water temperature monitor remains alight altitude operation)	<ul style="list-style-type: none"> • Clogged radiator fins or damaged fins • Defective thermostat • Loose radiator filler cap (high altitude operation) • Defective monitor panel 	<ul style="list-style-type: none"> (• Replace) (• Replace)
Engine does not start when starting motor is turned	<ul style="list-style-type: none"> • Lack of fuel • Air in fuel system • No fuel in fuel filter • Starting motor cranks engine sluggishly • Defective valve compression 	<ul style="list-style-type: none"> • Add fuel, see CHECK BEFORE STARTING • Repair place where air is sucked in (• Replace pump or nozzle) • See ELECTRICAL SYSTEM (• Adjust valve clearance)
Exhaust gas is white or blue	<ul style="list-style-type: none"> • Too much oil in oil pan • Improper fuel 	<ul style="list-style-type: none"> • Add oil to specified level, see CHECK BEFORE STARTING • Change to specified fuel
Exhaust gas occasionally turns black	<ul style="list-style-type: none"> • Clogged air cleaner element • Defective nozzle • Defective compression • Defective turbocharger 	<ul style="list-style-type: none"> • Clean or replace, see WHEN REQUIRED (• Replace nozzle) (• Adjust valve clearance) (• Clean or replace, turbocharger)
Combustion noise occasionally makes breathing sound	<ul style="list-style-type: none"> • Defective nozzle • Lack of fuel (in Air) 	<ul style="list-style-type: none"> (• Replace nozzle) • Add fuel
Abnormal noise generated (combustion or mechanical)	<ul style="list-style-type: none"> • Low grade fuel being used • Overheating • Damage inside muffler • Excessive valve clearance 	<ul style="list-style-type: none"> • Change to specified fuel • See item "Indicator of water temperature gauge is in red range on right side of gauge". (• Replace muffler) (• Adjust valve clearance)
Monitor displays error code	Please contact your Komatsu distributor	
Alarm buzzer sounds		
Engine horsepower lowered suddenly (Engine is running in duration mode)		

MAINTENANCE

WARNING

Please read and make sure that you understand the SAFETY section before reading this section.

GUIDES TO MAINTENANCE

Do not perform any inspection and maintenance operation that is not found in this manual.
Stop the machine on flat hard ground when performing inspections and maintenance.

CHECK SERVICE METER:

Check the service meter reading every day to see if the time has come for any necessary maintenance to be performed.

KOMATSU GENUINE REPLACEMENT PARTS:

Use Komatsu genuine parts specified in the Parts Book as replacement parts.

KOMATSU GENUINE OILS:

For lubrication of the machine, use the Komatsu genuine lubricants. Moreover use oil of the specified viscosity according to the ambient temperature.

ALWAYS USE CLEAN WASHER FLUID:

Use automobile window washer fluid, and be careful not to let any dirt get into it.

CLEAN OIL AND GREASE:

Use clean oil and grease. Also, keep the containers of the oil and grease clean. Keep foreign materials away from oil and grease.

CHECK FOREIGN MATERIAL IN DRAINED OIL:

After oil is changed or filters are replaced, check the old oil and filters for metal particles and foreign materials. If large quantity of metal particles or foreign materials are found, always report to the person in charge, and carry out suitable action.

FUEL STRAINER:

If your machine is equipped with a fuel strainer, do not remove it while fueling.

WELDING INSTRUCTIONS:

- Turn off the engine starting switch.
- Do not apply more than 200 V continuously.
- Connect grounding cable within 1 m (3.3 ft) of the area to be welded. If grounding cable is connected near instruments, connectors, etc., the instruments may malfunction.
- If a seal or bearing happens to come between the part being welded and grounding point, change the grounding point to avoid such parts.
- Do not use the area around the work equipment pins or the hydraulic cylinders as the grounding point.

OBJECTS IN YOUR POCKETS:

- When opening inspection windows or the oil filler port of the tank to carry out inspection, be careful not to drop nuts, bolts, or tools inside the machine.
If such things are dropped inside the machine, it may cause damage and/or malfunction of the machine, and will lead to failure. If you drop anything inside the machine, always remove it immediately.
- Do not put unnecessary things in your pockets. Carry only things which are necessary for inspection.

DUSTY WORKSITES:

When working at dusty worksites, do as follows:

- Inspect the dust indicator more frequently to see if the air cleaner is clogged.
Clean the air cleaner element at a shorter interval than specified.
On machines equipped with an air cleaner clogging monitor, the check can be carried out with the monitor.
- Clean the radiator core frequently to avoid clogging.
- Clean and replace the fuel filter frequently.
- Clean electrical components, especially the starting motor and alternator, to avoid accumulation of dust.
- When inspecting or changing the oil, move the machine to a place that is free of dust to prevent dirt from getting into the oil.

AVOID MIXING OILS:

If a different brand or grade of oil has to be added, drain the old oil and replace all the oil with the new brand or grade of oil. Never mix different brand or grade of oil.

PRECAUTIONS WHEN OPENING AND CLOSING ENGINE SIDE COVER:

- When standing on track to open the engine side cover, adopt a standing position, hold the side cover with both thumbs, and open it slowly with your other fingers.

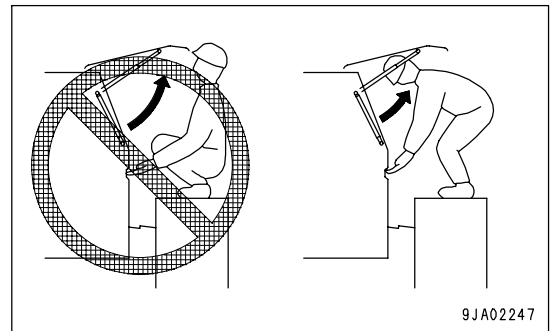
**LOCKING INSPECTION COVERS:**

Lock inspection cover securely into position with the lock bar. If inspection or maintenance is performed with inspection cover not locked in position, there is a danger that it may be suddenly blow shut by the wind and cause injury to the worker.

BLEEDING AIR:

When hydraulic equipment has been repaired or replaced, or the hydraulic piping has been removed and installed again, the air must be bled from the circuit. For details, see "BLEEDING AIR IN HYDRAULIC SYSTEM (PAGE 4-43)".

PRECAUTIONS WHEN INSTALLING HYDRAULIC HOSES:

- When removing parts at locations where there are O-rings or gasket seals, clean the mounting surface, and replace with new parts.
When doing this, be careful not to forget to assemble the O-rings and gaskets.
- When installing the hoses, do not twist them or bend them sharply. If they are installed so, their service life will be shortened extremely and they may be damaged.

CHECKS AFTER INSPECTION AND MAINTENANCE:

If you forget to perform the checks after inspection and maintenance, unexpected problems may occur, and this may lead to serious injury or property damage. Always do the following:

- Checks after operation (with engine stopped)
 - Have any inspection and maintenance points been forgotten?
 - Have all inspection and maintenance items been performed correctly?
 - Have any tools or parts been dropped inside the machine? It is particularly dangerous if parts are dropped inside the machine and get caught in the lever linkage mechanism.
 - Are there any leakage of coolant or oil? Have all nuts and bolts been tightened?
- Checks when operating engine
 - For details of the checks when operating the engine, see "PROPER TOOLS (PAGE 2-29)" and pay careful attention to safety.
 - Are the inspection and maintenance items working properly?
 - Is there any leakage of fuel or oil when the engine speed is raised?

OUTLINES OF SERVICE

- Always use Komatsu genuine parts for replacement parts, grease or oil.
- When changing the oil or adding oil, do not mix different types of oil. When changing the type of oil, drain all the old oil and fill completely with the new oil. Always replace the filter at the same time. (There is no problem if the small amount of oil remaining in the piping mixes with the new oil.)
- Unless otherwise specified, when the machine is shipped from the factory, it is filled with the oil and coolant listed in the table below.

Item	Type
Engine oil pan	Engine oil EO15W40DH (Komatsu genuine parts)
Power train case Final drive case Damper case	Power train oil TO30 (Komatsu genuine parts)
Hydraulic tank	Power train oil TO10 (Komatsu genuine parts)
Radiator	Supercoolant AF-NAC (Density: 30% or above) (Komatsu genuine parts)

HANDLING OIL, FUEL, COOLANT, AND PERFORMING OIL CLINIC

OIL

- Oil is used in the engine and hydraulic equipment under extremely severe conditions (high temperature, high pressure), and deteriorates with use.
Always use oil that matches the grade and maximum and minimum ambient temperatures recommended in the Operation and Maintenance Manual. Even if the oil is not dirty, always change the oil at the specified interval.
- Oil corresponds to blood in the human body, always be careful when handling it to prevent any impurities (water, metal particles, dirt, etc.) from getting in.
The majority of problems with the machine are caused by the entry of such impurities.
Take particular care not to let any impurities get in when storing or adding oil.
- Never mix oils of different grades or brands.
- Always add the specified amount of oil.
Having too much oil or too little oil are both causes of problems.
- If the oil in the work equipment is not clear, there is probably water or air getting into the circuit. In such cases, please contact your Komatsu distributor.
- When changing the oil, always replace the related filters at the same time.
- We recommend you have an analysis made of the oil periodically to check the condition of the machine. For those who wish to use this service, please contact your Komatsu distributor.
- When using commercially available oil, it may be necessary to reduce the oil change interval.
We recommend that you use the Komatsu oil clinic to carry out a detailed checks of the characteristics of the oil.

FUEL

- To prevent the moisture in the air from condensing and forming water inside the fuel tank, always fill the fuel tank after completing the day's work.
- The fuel pump is a precision instrument, and if fuel containing water or dirt is used, it cannot work properly.
- Be extremely careful not to let impurities get in when storing or adding fuel.
- Always use the fuel specified in the Operation and Maintenance Manual.
Fuel may congeal depending on the temperature when it is used (particularly in low temperatures below -15°C (5°F)), so it is necessary to use the fuel that is suitable for the temperature.
- Before starting the engine, or when 10 minutes have passed after adding fuel, drain the sediment and water from the fuel tank.
- If the engine runs out of fuel, or if the filters have been replaced, it is necessary to bleed the air from the circuit.
- If there is any foreign material in the fuel tank, wash the tank and fuel system.

COOLANT AND WATER FOR DILUTION

- The coolant has the important function of preventing corrosion as well as preventing freezing. Even in the areas where freezing is not an issue, the use of antifreeze coolant is essential. Komatsu machines are supplied with Komatsu Supercoolant (AF-NAC). Komatsu Supercoolant (AF-NAC) has excellent anticorrosion, antifreeze and cooling properties and can be used continuously for 2 years or 4000 hours. As a basic rule, we do not recommend the use of any coolant other than Komatsu genuine supercoolant (AF-NAC). If you use another coolant, it may cause serious problems such as corrosion of the engine and parts of the cooling system that use light metals such as aluminum.
- When diluting the antifreeze coolant, use distilled water or tap water (soft water). Natural water, such as a river water or well water (hard water), contains large amounts of minerals (calcium, magnesium, etc.), and this makes it easier for scale to form inside the engine or radiator. Once scale is deposited inside the engine or radiator, it is extremely difficult to remove. It also causes overheating due to poor heat exchange, so when you dilute the coolant, we recommend that you use water with an overall hardness of less than 100 PPM.
- When using antifreeze, always observe the precautions given in the Operation and Maintenance Manual.
- Antifreeze coolant is flammable, so be sure to keep it away from flame.
- The ratio of Supercoolant (AF-NAC) to water differs according to the ambient temperature. For details of the ratio when mixing, see "CLEAN INSIDE OF COOLING SYSTEM (PAGE 4-20)". Even in areas where it is not necessary to prevent freezing, use Supercoolant (AF-NAC) at a mixing ratio of at least 30% to prevent corrosion of the cooling system. Supercoolant (AF-NAC) may be supplied in premix. In this case, never add diluting water.
- If the engine overheats, wait for the engine to cool before adding coolant.
- If the coolant level is low, it will cause overheating, and will also cause problems with corrosion due to air entering the coolant.

GREASE

- Grease is used to prevent seizure and noises at the joints.
- This construction equipment is used under heavy-duty conditions. Always use the recommended grease and follow the change intervals and recommended ambient temperatures given in this Operation and Maintenance Manual.
- The nipples not included in the MAINTENANCE section are nipples used when overhauling, so they do not need grease. If any part becomes stiff or generates noise after being used for a long time, grease it.
- Always wipe off all of the old grease that is pushed out when greasing. Be particularly careful to wipe off the old grease in places where sand or dirt sticking in the grease would cause wear of the rotating parts.

CARRYING OUT KOWA (Komatsu Oil Wear Analysis)

KOWA is a maintenance service that makes it possible to prevent machine failures and downtime. With KOWA, the oil is periodically sampled and analyzed. This enables early detection of wear of the machine drive parts and other problems.

We strongly recommend you to use this service. The oil analysis is carried out at actual cost, so the cost is low, and the results of the analysis are reported together with recommendations which will reduce repair costs and machine downtime.

KOWA ANALYSIS ITEMS

- Measurement of density of metal wear particles

This uses an ICP (Inductively Coupled Plasma) analyzer to measure the density of iron, copper, and other metal wear particles in the oil.

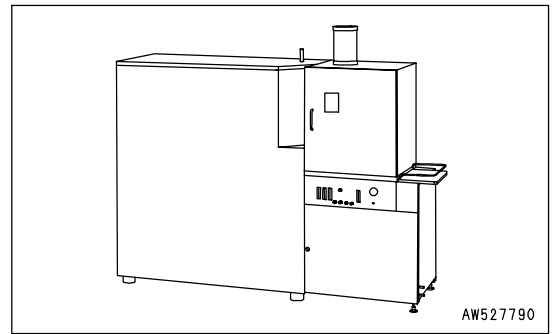

- Measurement of quantity of particles

This uses a PQI (Particle Quantifier Index) measurer to measure the quantity of iron particles of 5 μ m or more, enabling early detection of failures.

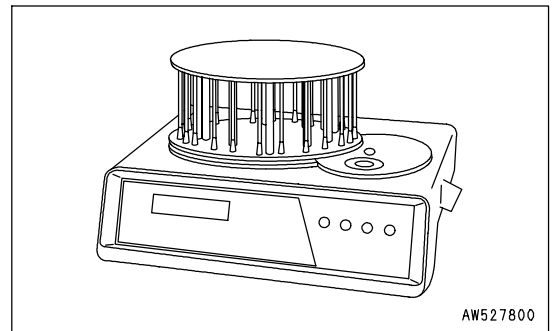

- Others

Measurements are made of items such as the ratio of water in the oil, density of the antifreeze coolant, ratio of fuel in the oil, and dynamic viscosity, enabling a highly precise diagnosis of the machine's health.

OIL SAMPLING

- Sampling interval
 - 250 hours: Engine
 - 500 hours: Other components
- Precautions when sampling
 - Make sure that the oil is well mixed before sampling.
 - Perform sampling at regular fixed intervals.
 - Do not perform sampling on rainy or windy days when water or dust can get into the oil.

For further details of KOWA, please contact your Komatsu distributor.

STORING OIL AND FUEL

- Keep indoors to prevent any water, dirt, or other impurities from getting in.
- When keeping drum cans for a long period, put the drum on its side so that the filler port of the drums is at the side to prevent moisture from being sucked in.
If drums have to be stored outside, cover them with a waterproof sheet or take other measures to protect them.
- To prevent any change in quality during long-term storage, be sure to use in the order of first in - first out (use the oldest oil or fuel first).

FILTERS

- Filters are extremely important safety parts. They prevent impurities in the fuel and air circuits from entering important equipment and causing problems.

Replace all filters periodically. For details, see the Operation and Maintenance Manual.

However, when working in severe conditions, replace the filters at shorter intervals according to the oil and fuel (sulfur content) being used.

- Never try to clean the filters (cartridge type) and use them again. Always replace with new filters.
- When replacing oil filters, check if any metal particles are attached to the old filter. If any metal particles are found, contact your Komatsu distributor.
- Do not open packs of spare filters until just before they are to be used.
- Always use Komatsu genuine filters.

OUTLINE OF ELECTRIC SYSTEM

- It is extremely dangerous if the electrical equipment becomes wet or the covering of the wiring is damaged. This will cause an electrical short circuit and may lead to malfunction of the machine. Do not wash the inside of the operator's cab with water. When washing the machine, be careful not to let water get into the electrical components.
- Service relating to the electric system is checking fan belt tension, checking damage or wear to the fan belt and checking battery fluid level.
- Never install any electric components other than those specified by Komatsu.
- External electro-magnetic interference may cause malfunction of the control system controller, before installing a radio receiver or other wireless equipment, contact your Komatsu distributor.
- Be careful to keep the electric system free of water when washing the machine or when it rains.
- When working at the seashore, carefully clean the electric system to prevent corrosion.
- When installing electrical equipment, connect it to the special power source connector.
Do not connect the optional power source to the fuse, starting switch, or battery relay.

WEAR PARTS

Replace wear parts such as the filter element or cutting edge at the time of periodic maintenance or before they reach the wear limit. The wear parts should be replaced correctly in order to ensure more economic use of the machine. When replacing parts, always use Komatsu genuine parts.

As a result of our continuous efforts to improve product quality, the part number may change, so inform your Komatsu distributor of the machine serial number and check for the latest part number when ordering parts.

WEAR PARTS LIST

The parts in parentheses are to be replaced at the same time.

Item	Part No.	Part Name	Weight (kg(lb))	Q'ty	Replacement frequency			
Engine oil filter	600-211-1340	Cartridge	-	1	Every 500 hours service			
Transmission filter	154-49-71990 (07000-12130)	Element (O-ring)	- -	1 (1)				
Pre-fuel filter	600-319-3440	Cartridge (with cap)	-	1				
Corrosion resistor	600-411-1151	Cartridge	-	1	Every 1000 hours service			
Fuel filter	600-319-3550	Cartridge (with cap)	-	1				
Hydraulic tank breather element	20Y-60-21410	Element	-	1				
Hydraulic oil filter	207-60-71181 (07000-15195)	Element (O-ring)	- -	1 (1)	Every 2000 hours service			
Air cleaner	600-185-5100	Element assembly	-	1	-			
Blade	D85 EX	154-70-11314	Cutting edge	52.9 (117)	1	-		
		154-71-43190 (154-71-41270)	Cutting edge (Bolt)	41.5 (92) -	2 (20)			
		01643-21845	(Washer)	-	(20)			
		154-70-22270	(Nut)	-	(20)			
		150-70-21346	End bit (right)	26.2 (58)	1			
		150-70-21356 (154-71-41270)	End bit (left) (Bolt)	26.2 (58) -	1 (12)			
		01643-21845	(Washer)	-	(12)			
		154-70-22270	(Nut)	-	(12)			
		D85 PX	154-70-11314 (154-71-41270)	Cutting edge (Bolt)	52.9 (117) -		3 (24)	-
			01643-21845	(Washer)	-		(24)	
			154-70-22270	(Nut)	-		(24)	
			150-70-21346	End bit (right)	26.2 (58)		1	
			150-70-21356 (154-71-41270)	End bit (left) (Bolt)	26.2 (58) -		1 (12)	
			01643-21845	(Washer)	-		(12)	
154-70-22270	(Nut)		-	(12)				
Ripper (Fixed multi-shank ripper) (Variable multi-shank ripper)	D85 EX	154-78-31330	Protector	12.9 (28.44)	3	-		
		175-78-31230	Point	15 (33.08)	3			
		09244-02508	(Pin)	-	(9)			

NOTICE

When handling parts that weigh more than 25 kg (55 lb), remember that they are heavy objects, and take the necessary care.

RECOMMENDED FUEL, COOLANT, AND LUBRICANT

- Komatsu genuine oils are adjusted to maintain the reliability and durability of Komatsu construction equipment and components.

In order to keep your machine in the best conditioner for long periods of time, it is essential to follow the instructions in this Operation and Maintenance Manual.

- Failure to follow these recommendations may result in shortened life or excess wear of the engine, power train, cooling system, and/or other components.
- Commercially available lubricant additives may be good for the machine, but they may also cause harm. Komatsu does not recommend any commercially available lubricant additive.
- Use the oil recommended according to the ambient temperature in the chart below.
- Specified capacity means the total amount of oil including the oil in the tank and the piping. Refill capacity means the amount of oil needed to refill the system during inspection and maintenance.
- When starting the engine in temperatures below 0°C (32°F), be sure to use the recommended multi-grade oil, even if the ambient temperature may become higher during the course of the day.
- If the machine is operated at a temperature below -20°C (-4°F), a separate device is needed, so consult your Komatsu distributor.
- When the fuel sulfur content is less than 0.5%, change the engine oil according to the period inspection table given in this Operation and Maintenance Manual.

If the fuel sulfur content is more than 0.5%, change the oil according to the following table.

Sulfur content (%)	Oil change interval
Less than 0.5	500 hours
0.5 - 1.0	250 hours
1.0 and up	Not recommendable (*)

* If these fuels are used, there is danger that serious trouble may occur because of early deterioration of the engine oil or early wear of the internal parts of the engine. If the local situation makes it necessary to use these fuels, always remember the following.

- 1) Be sure to check Total Basic Number (TBN) of oil frequently by TBN handy checker etc., and change oil based on the result.
- 2) Always be aware that oil change interval is extremely shorter than standard.
- 3) Be sure to carry out periodic engine inspection by distributor's expert since change interval of periodic replacement parts and overhaul interval are also shorter.

USE OF FUEL, COOLANT AND LUBRICANTS ACCORDING TO AMBIENT TEMPERATURE

Reservoir	Fluid Type	Ambient Temperature									Recommended Komatsu Fluids
		-22 -30	-4 -20	14 10	32 0	50 10	68 20	86 30	104 40	122 50	
Engine oil pan	Engine oil	(Note.1)									Komatsu EOS0W30
		(Note.1)									Komatsu EOS5W40
Damper case Idler (each)	Power train oil (Note.2)	(Note.5)									Komatsu EO10W30DH
		(Note.5)									Komatsu EO15W40DH
		(Note.5)									Komatsu EO30DH
Power train case	Power train oil	(Note.5)									TO30
		(Note.5)									TO10
Final drive case (each)	Power train oil	(Note.5)									TO30
		(Note.5)									TO30
Hydraulic system	Hydraulic oil	(Note.5)									TDS5W30
		(Note.5)									TO10
	Engine oil	(Note.5)									HO46-HM
		(Note.5)									Komatsu EO10W30DH Komatsu EO15W40DH
Grease lifting	Hyper grease (Note.3) Lithium EP grease	(Note.5)									G2-T, G2-TE
		(Note.5)									G2-LI G2-LI-S
Cooling system	Supercoolant AF-NAC (Note.4)	(Note.5)									AF-NAC
Fuel tank	Diesel fuel	(Note.5)									ASTM Grade No. 1-D S-5 ASTM Grade No. 2-D S30 ASTM Grade No. 2-D S-5 ASTM Grade No. 2-D S30

• ASTM: American Society of Testing and Material

		Engine oil pan	Damper case	Idler (each)	Power train oil pan (incl. transmission, torque converter and bevel gear cases)	Final drive case (each)	Hydraulic system	Fuel tank	Cooling system
Specified amount	liter	44	1.5	0.35	90	(EX)26 (PX)36	(EX)120 (PX)106	490	82
	US gal	11.62	0.40	0.09	23.78	(EX)6.87 (PX)9.51	(EX)31.70 (PX)28.01	129.46	21.66
Refill capacity	liter	38	1.5	0.35	60	(EX)26 (PX)36	71	-	-
	US gal	10.04	0.40	0.09	15.85	(EX)6.87 (PX)9.51	18.76	-	-

NOTICE

Always use diesel oil for the fuel.

To ensure good fuel consumption characteristics and exhaust gas characteristics, the engine mounted on this machine uses an electronically controlled high-pressure fuel injection device. This device requires high precision parts and lubrication, so if low viscosity fuel with low lubricating ability is used, the durability may drop markedly.

Note 1: HTHS (High-Temperature High-Shear Viscosity 150°C), specified by ASTM D4741 must be equal to or higher than 3.5 mPa-S. Komatsu EOS0W30 and EOS5W40 are the most suitable oils.

Note 2: Powertrain oil has different properties from engine oil. Be sure to use the recommended oils.

Note 3: Hyper grease (G2-T, G2-TE) has a high performance.

When it is necessary to improve the lubricating ability of the grease in order to prevent squeaking of pins and bushings, the use of G2-T or G2-TE is recommended.

Note 4: Supercoolant (AF-NAC)

1) Coolant has the important function of anticorrosion as well as antifreeze.

Even in the areas where freezing is not an issue, the use of antifreeze coolant is essential.

Komatsu machines are supplied with Komatsu Supercoolant (AF-NAC). Komatsu Supercoolant (AF-NAC) has excellent anticorrosion, antifreeze and cooling properties and can be used continuously for 2 years or 4000 hours. Komatsu Supercoolant (AF-NAC) is strongly recommended wherever available.

2) For details of the ratio when diluting super coolant with water, see "CLEAN INSIDE OF COOLING SYSTEM (PAGE 4-20)".

When the machine is shipped from the factory, it may be filled with coolant containing 30% or more Supercoolant (AF-NAC). In this case, no adjustment is needed for temperatures down to -10°C (14°F). (never dilute with water)

3) To maintain the anticorrosion properties of Supercoolant (AF-NAC), always keep the density of Supercoolant between 30% and 68%.

Note 5: In this range, preheating with a starting aid is necessary.

RECOMMENDED BRANDS, RECOMMENDED QUALITY FOR PRODUCTS OTHER THAN KOMATSU GENUINE OIL

When using commercially available oils other than Komatsu genuine oil, or when checking the latest specifications, refer to the Komatsu web page or consult your Komatsu distributor.

STANDARD TIGHTENING TORQUES FOR BOLTS AND NUTS

TORQUE LIST



If nuts, bolts, or other parts are not tightened to the specified torque, it will cause looseness or damage to the tightened parts, and this will cause failure of the machine or problems with operation.

Always pay careful attention when tightening parts.

Unless otherwise specified, tighten the metric nuts and bolts to the torque shown in the table below. If it is necessary to replace any nut or bolt, always use a Komatsu genuine part of the same size as the part that was replaced.

Thread diameter of bolt (a)(mm)	Width across flats (b)(mm)	Tightening torque					
		Target value			Service limit		
		Nm	kgm	lbft	Nm	kgm	lbft
6	10	13.2	1.35	9.8	11.8-14.7	1.2-1.5	8.7-10.8
8	13	31	3.2	23.1	27-34	2.8-3.5	20.3-25.3
10	17	66	6.7	48.5	59-74	6.0-7.5	43.4-54.2
12	19	113	11.5	83.2	98-123	10.0-12.5	72.3-90.4
14	22	177	18	130.2	157-196	16.0-20.0	115.7-144.7
16	24	279	28.5	206.1	245-309	25.0-31.5	180.8-227.8
18	27	382	39	282.1	343-425	35.0-43.5	253.2-314.6
20	30	549	56	405.0	490-608	50.0-62.0	361.7-448.4
22	32	745	76	549.7	662-829	67.5-84.5	488.2-611.2
24	36	927	94.5	683.5	824-1030	84.0-105.0	607.6-759.5
27	41	1320	135.0	976.5	1180-1470	120.0-150.0	868.0-1085.0
30	46	1720	175.0	1265.8	1520-1910	155.0-195.0	1121.1-1410.4
33	50	2210	225.0	1627.4	1960-2450	200.0-250.0	1446.6-1808.3
36	55	2750	280.0	2025.2	2450-3040	250.0-310.0	1808.3-2242.2
39	60	3280	335.0	2423.1	2890-3630	295.0-370.0	2133.7-2676.2

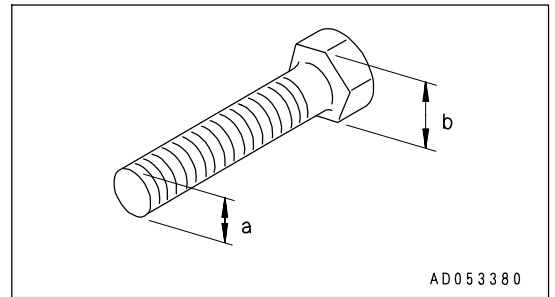

Apply the following table for Hydraulic Hose.

Nominal- No. of threads (a)	Width across flats (b) mm	Tightening torque					
		Target valve			Permissible range		
		Nm	kgm	lbft	Nm	kgm	lbft
9/16 -18UNF	19	44	4.5	32.5	34 - 54	3.5 - 5.5	25.3 - 39.8
11/16 -16UN	22	74	7.5	54.2	54 - 93	5.5 - 9.5	39.8 - 68.7
13/16 -16UN	27	103	10.5	75.9	84 - 132	8.5 - 13.5	61.5 - 97.6
1 -14UNS	32	157	16.0	115.7	128 - 186	13.0 - 19.0	94.0 - 137.4
1-3/16 -12UN	36	216	22.0	159.1	177 - 245	18.0 - 25.0	130.2 - 180.8

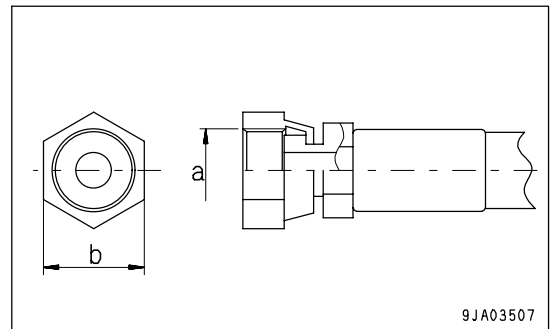

PERIODIC REPLACEMENT OF SAFETY CRITICAL PARTS

For using the machine safely for an extended period of time, you are required to periodically replace the safety (critical and fire prevention) related parts listed in the table of important parts on the following page.

Material quality of these parts can change as time passes and they are likely to wear out or deteriorate. However, it is difficult to determine the extent of wear or deterioration at the time of periodic maintenance. Hence, it is required to replace them with new ones regardless of their condition after a certain period of usage. This is important to ensure that these parts maintain their full performance at all times.

Furthermore, should anything abnormal be found on any of these parts, replace it with a new one even if the periodic replacement time for the part has not yet arrived.

If any of the hose clamps show deterioration like deformation or cracking, replace the clamps at the same time as the hoses.

Also perform the following checks with hydraulic hoses which need to be replaced periodically. Tighten all loose clamps and replace defective hoses, as required.

When replacing hoses, always replace O-rings, gaskets, and other such parts at the same time.

Have your Komatsu distributor replace the critical parts.

SAFETY CRITICAL PARTS

Replace wear parts such as the filter element or air cleaner element at the time of periodic maintenance or before they reach the wear limit. The wear parts should be replaced correctly in order to ensure more economic use of the machine. When replacing parts, always use Komatsu genuine parts.

As a result of our continuous efforts to improve product quality, the part number may change, so inform your Komatsu distributor of the machine serial number and check for the latest part number when ordering parts.

NO.	Safety critical parts for periodic replacement	Q'ty	Replacement frequency
1	Fuel hose between fuel tank and fuel strainer	2	Every 2 years or 4000 hours, whichever comes sooner
2	Fuel hose between fuel strainer and pre-fuel filter	2	
3	Fuel hose between pre-fuel filter and feed pump	1	
4	Fuel return hose between common rail relay block and relay elbow	1	
5	Fuel return hose between relay elbow and fuel tank	1	
6	Fuel return hose between supply pump and fuel tank	1	
7	Hose between Torque converter oil cooler - power train assembly	1	
8	Hose between power train pump - power train filter	1	
9	Hose between power train filter - power train assembly	1	
10	Hose between transmission case - steering case	1	
11	Inspection hose assembly for power train pressure	1	
12	Hose between HSS motor - main control valve	2	
13	Hose between HSS pump - central drain block	1	
14	Hose between HSS motor - central drain block	1	
15	Hose between drain relay block (power train) - hydraulic tank	1	
16	Hose between oil cooler - central drain block	2	
17	Hose between Fan pump - self-reducing pressure valve	1	
18	Hose between self-reducing pressure valve - fan motor	3	
19	Hose between PCC divider block - main control valve	2	

NO.	Safety critical parts for periodic replacement	Q'ty	Replacement frequency
20	Hose between PCC divider block - fan pump	1	Every 2 years or 4000 hours, whichever comes sooner
21	Hose between PCC divider block - main control lock valve	2	
22	Hose between oil cooler bypass valve - hydraulic oil cooler	2	
23	Hose between self-reducing pressure valve - central drain block	1	
24	Hose between main control valve - central drain block	1	
25	Hose between fan motor - hydraulic tank	4	
26	Hose between self-reducing pressure valve - PPC lock valve	1	
27	Hose between PPC lock valve - blade PPC valve	1	
28	Hose between PPC lock valve - ripper PPC valve	1	
29	Hose between blade PPC valve - main control valve	4	
30	Hose between ripper PPC valve - main control valve (fixed multi-shank ripper)	2	
31	Hose between ripper PPC valve - main control valve (variable multi-shank ripper)	4	
32	Hose between blade PPC valve - central drain block	1	
33	Hose between ripper PPC valve - central drain block	1	
34	Hose between HSS pump - main control valve	2	
35	Hose between oil cooler bypass valve - hydraulic tank	1	
36	Hose between central drain block - hydraulic tank	1	
37	Accumulator (for operating circuit)	1	
38	Injector nozzle chip	1S	
39	Seat belt	1	
40	High-pressure tube clamp	1S	Every 8000 hours
41	Fuel spray prevention cap	1S	

MAINTENANCE SCHEDULE CHART

MAINTENANCE SCHEDULE CHART

The maintenance interval for adjusting the injector differs according to the exhaust gas regulations for each area. When carrying out the adjustment, check the maintenance time. For details, see "ADJUST INJECTOR (PAGE 4-18)".

INITIAL 250 HOURS SERVICE (ONLY AFTER THE FIRST 250 HOURS)

REPLACE POWER TRAIN OIL FILTER ELEMENT	4- 55
CHANGE OIL IN POWER TRAIN CASE, WASH STRAINER (POWER TRAIN PUMP STRAINER, SCAVENGING PUMP STRAINER)	4- 56
CHANGE OIL IN FINAL DRIVE CASE	4- 59
CHANGE OIL IN HYDRAULIC TANK, REPLACE HYDRAULIC OIL FILTER ELEMENT, CLEAN HYDRAULIC TANK STRAINER	4- 63

WHEN REQUIRED

CLEAN INSIDE OF COOLING SYSTEM	4- 20
CHECK, CLEAN AND REPLACE AIR CLEANER ELEMENT	4- 24
CHECK AND ADJUST TRACK TENSION	4- 28
CHECK AND TIGHTEN TRACK SHOE BOLTS	4- 30
ADJUST IDLER CLEARANCE	4- 31
REVERSE AND REPLACE THE END BITS AND CUTTING EDGES	4- 33
CLEAN, CHECK RADIATOR FINS AND OIL COOLER FINS	4- 34
CLEAN FUEL TANK STRAINER	4- 36
DRAIN WATER AND SEDIMENT IN FUEL TANK	4- 36
CLEAN STEERING CLUTCH CASE BREATHER	4- 36
CHECK UNDERCARRIAGE OIL	4- 37
CLEAN AIR CONDITIONER AIR FILTER (FRESH/RECIRC FILTER)	4- 38
CHECK AND ADJUST AIR CONDITIONER	4- 38
LUBRICATE DOOR HINGE	4- 40
CHECK DOOR LATCH	4- 40
CHECK DOOR LOCK STRIKER	4- 40
REPLACE DOOR DAMPER	4- 41
CHECK WINDOW WASHER FLUID LEVEL, ADD FLUID	4- 41
REPLACE WIPER BLADE	4- 42
BLEEDING AIR IN HYDRAULIC SYSTEM	4- 43
CHECK ELECTRICAL INTAKE AIR HEATER	4- 43
LUBRICATING	4- 43

CHECK BEFORE STARTING

EVERY 250 HOURS SERVICE

LUBRICATING	4- 45
CHECK ALTERNATOR DRIVE BELT TENSION, ADJUST	4- 47
CHECK LEVEL OF BATTERY ELECTROLYTE	4- 48
CHECK BRAKE PERFORMANCE	4- 50
CHECK OIL LEVEL IN DAMPER CASE, ADD OIL	4- 51

EVERY 500 HOURS SERVICE

CHANGE OIL IN ENGINE OIL PAN, REPLACE ENGINE OIL FILTER CARTRIDGE ----- 4- 52
 REPLACE PRE-FUEL FILTER CARTRIDGE ----- 4- 53
 REPLACE POWER TRAIN OIL FILTER ELEMENT ----- 4- 55
 CHECK OIL LEVEL IN FINAL DRIVE CASE, ADD OIL ----- 4- 55

EVERY 1000 HOURS SERVICE

CHANGE OIL IN POWER TRAIN CASE, WASH STRAINER (POWER TRAIN PUMP STRAINER, SCAVENGING PUMP STRAINER) ----- 4- 56
 REPLACE HYDRAULIC TANK BREATHER ELEMENT ----- 4- 58
 CHANGE OIL IN FINAL DRIVE CASE ----- 4- 59
 CHECK, CLEAN FUEL STRAINER ----- 4- 59
 REPLACE FUEL MAIN FILTER CARTRIDGE ----- 4- 60
 CHECK TIGHTENING PARTS OF TURBOCHARGER ----- 4- 61
 REPLACE CORROSION RESISTOR CARTRIDGE ----- 4- 62

EVERY 2000 HOURS SERVICE

CHANGE OIL IN HYDRAULIC TANK, REPLACE HYDRAULIC OIL FILTER ELEMENT, CLEAN HYDRAULIC TANK STRAINER ----- 4- 63
 CHANGE OIL IN DAMPER CASE, CLEAN DAMPER BREATHER ----- 4- 64
 CHECK PIVOT BEARING OIL LEVEL, ADD OIL ----- 4- 65
 CHECKING CHARGE PRESSURE OF NITROGEN GAS IN ACCUMULATOR (FOR CONTROL CIRCUIT) ----- 4- 66
 CLEAN ENGINE BREATHER ELEMENT ----- 4- 69
 CHECK ALTERNATOR, STARTING MOTOR ----- 4- 69
 CHECK VIBRATION DAMPER ----- 4- 69
 CLEAN AND CHECK TURBOCHARGER ----- 4- 69
 CHECK PLAY OF TURBOCHARGER ROTOR ----- 4- 69
 CHECK ENGINE VALVE CLEARANCE, ADJUST ----- 4- 69
 CHECK INJECTOR (EPA EXHAUST GAS REGULATION AREAS ONLY) ----- 4- 69

EVERY 4000 HOURS SERVICE

REPLACE ACCUMULATOR (FOR CONTROL CIRCUIT) ----- 4- 70
 CHECK WATER PUMP ----- 4- 70
 CHECK INJECTOR (All areas except EPA exhaust gas regulation areas) ----- 4- 70
 REPLACE INJECTOR ASSEMBLY (EPA exhaust gas regulation areas only) ----- 4- 70
 CHECKING FOR LOOSENESS OF HIGH-PRESSURE CLAMP, HARDENING OF RUBBER ----- 4- 71
 CHECKING FOR MISSING FUEL SPRAY PREVENTION CAP, HARDENING OF RUBBER ----- 4- 72
 CHECK MAIN FRAME, WORK EQUIPMENT (BLADE, RIPPER) ----- 4- 73

EVERY 8000 HOURS SERVICE

REPLACE INJECTOR NOZZLE TIP (All areas except EPA exhaust gas regulation areas) ----- 4- 74
 REPLACE HIGH-PRESSURE PIPING CLAMPS ----- 4- 74
 REPLACE FUEL SPLAY PREVENTION CAPS ----- 4- 74

ADJUST INJECTOR

This machine uses an engine that conforms with all exhaust gas regulations.

The exhaust gas regulations differ according to the applicable area. To ensure that the engine conforms with the regulations in the area of use and can fully display its performance, keep to the following periodic maintenance intervals when adjusting the injector.

If the periodic maintenance intervals are not observed correctly, the engine may not be able to display its performance fully, and it may also not conform with the regulations.

NOTICE

When transporting a machine from an A regulation area to a B regulation area, always replace all the injector assemblies before transporting the machine to the new area.

Check with your Komatsu distributor to confirm if your area of operation is an A regulation area or a B regulation area.

A REGULATION AREA

EPA regulation areas and areas with the regulations equivalent to EPA regulations

EVERY 2000 HOURS SERVICE

Check injector

Check the exhaust gas color visually. If there is any abnormality in the exhaust gas color, please ask your Komatsu distributor to carry out inspection or replacement. For details of the procedure if any abnormality is found, see Section "ENGINE (PAGE 3-152)".

EVERY 4000 HOURS SERVICE

Replace injector assembly

Ask your Komatsu distributor to carry out this work.

B REGULATION AREA

Areas not applying EPA regulations or areas not applying regulations equivalent to EPA regulations

EVERY 4000 HOURS SERVICE

Check injector

Check the exhaust gas color visually. If there is any abnormality in the exhaust gas color, please ask your Komatsu distributor to carry out inspection or replacement. For details of the procedure if any abnormality is found, see Section "ENGINE (PAGE 3-152)".

EVERY 8000 HOURS SERVICE

Replace injector nozzle tip

Ask your Komatsu distributor to carry out this work.

SERVICE PROCEDURE

INITIAL 250 HOURS SERVICE (ONLY AFTER THE FIRST 250 HOURS)

Perform the following maintenance only after the first 250 hours.

- Replace power train oil filter element
- Change power train case oil and wash strainer (power train pump strainer, scavenging pump strainer)
- Change oil in final drive case
- Change oil in hydraulic tank, replace hydraulic oil filter element, clean hydraulic tank strainer

For details of the methods of maintenance, see EVERY 500 HOURS SERVICE, EVERY 1000 SERVICE, EVERY 2000 HOURS SERVICE.

WHEN REQUIRED

CLEAN INSIDE OF COOLING SYSTEM



WARNING

- Immediately after the engine is stopped, the cooling water is at high temperature and the radiator is under high internal pressure. If the radiator cap is removed in this condition and the water is drained, it may cause burns. To prevent this, wait for the temperature to go down, then turn the cap slowly to release the internal pressure.
- The cleaning operation is carried out with the engine running. When standing up from the operator's seat or leaving the cab, set the parking brake lever and work equipment lock lever to the LOCK position.
- For details when starting the engine, see "CHECK BEFORE STARTING ENGINE, ADJUST (PAGE 3-76)" and "STARTING ENGINE (PAGE 3-95)".
- When the engine is running, never come close to the fan at the front of the machine. There is danger of touching the fan.
- When the engine is running, it is extremely dangerous to go under the machine during the cleaning operation. The machine may move unexpectedly, so never go under the machine when the engine is running.

Stop the machine on level ground when cleaning or changing the coolant.

Clean the inside of the cooling system, change the coolant according to the table below.

Antifreeze coolant	Interval for cleaning inside of cooling system and changing antifreeze coolant	Precautions for use
Komatsu supercoolant (AF-NAC)	Every two years or every 4000 hours whichever comes first	1*

*1: When using Komatsu Supercoolant (AF-NAC), there is no need to use a corrosion resistor.

When no corrosion resistor is used, use the special cover (600-411-9000). Please consult your Komatsu distributor about the method of installing.

When using corrosion resistor, use Komatsu genuine corrosion resistor. If you use another corrosion resistor, it may cause serious problems such as corrosion of the engine and parts of the cooling system that use light metals such as aluminum.

The coolant has the important function of preventing corrosion as well as preventing freezing.

Even in the areas where freezing is not an issue, the use of antifreeze coolant is essential.

Komatsu machines are supplied with Komatsu Supercoolant (AF-NAC). Komatsu Supercoolant (AF-NAC) has excellent anticorrosion, antifreeze and cooling properties and can be used continuously for 2 years or 4000 hours. As a basic rule, we do not recommend the use of any coolant other than Komatsu genuine supercoolant (AF-NAC). If you use another coolant, it may cause serious problems such as corrosion of the engine and parts of the cooling system that use light metals such as aluminum.

To maintain the anticorrosion properties of Supercoolant (AF-NAC), always keep the density of Supercoolant between 30% and 68%.

When deciding the ratio of antifreeze to water, check the lowest temperature in the past, and decide from the mixing table given below.

It is actually better to estimate and temperature about 10°C (18°F) lower when deciding the mixing ratio.

The mixing ratio depends on the ambient temperature, but it should always be a minimum of 30% by volume (antifreeze/total amount of coolant x 100).

Even in areas where it is not necessary to prevent freezing, use Supercoolant (AF-NAC) at a mixing ratio of at least 30% to prevent corrosion of the cooling system.

The freezing temperature of undiluted antifreeze is -15°C (5°F). Do not store undiluted antifreeze at a temperature of below -15°C (5°F).

Mixing rate of water and antifreeze

Min. atmospheric temperature	°C	-10	-15	-20	-25	-30	-35	-40
	°F	14	5	-4	-13	-22	-31	-40
Amount of antifreeze	liter	24.6	29.5	33.6	37.7	41.0	44.3	47.6
	US gal	6.50	7.79	8.88	9.96	10.83	11.70	12.58
Amount of water	liter	57.4	52.5	48.4	44.3	41.0	37.7	34.4
	US gal	15.17	13.87	12.79	11.70	10.83	9.96	9.90
Volume ratio (%)		30	36	41	46	50	54	58



WARNING

Antifreeze coolant is flammable, so keep it away from flame.

Antifreeze coolant is toxic. When removing the drain plug, be careful not to get water containing antifreeze coolant on you. If it gets in your eyes, flush your eyes with large amount of fresh water and see a doctor at once.

Use antifreeze and appropriate water for diluting (for details, see "COOLANT AND WATER FOR DILUTION (PAGE 4-6)")

We recommend use of an antifreeze density gauge to control the mixing proportions.



WARNING

When removing the drain plug, be careful not to be covered with the drained coolant.

1. Stop the engine, wait for the coolant to cool completely, then turn valve (2) of corrosion resistor (1) to the Close stopper position.

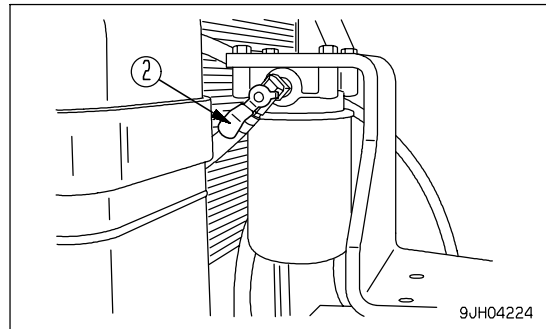
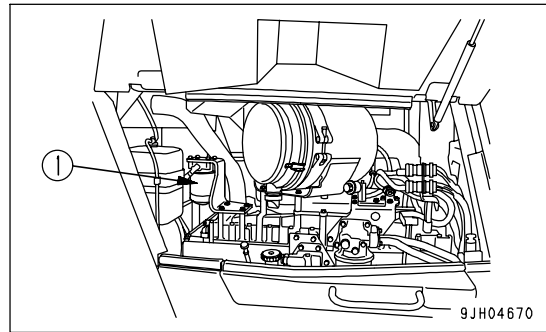

2. Turn main radiator cap (3) slowly, and remove.

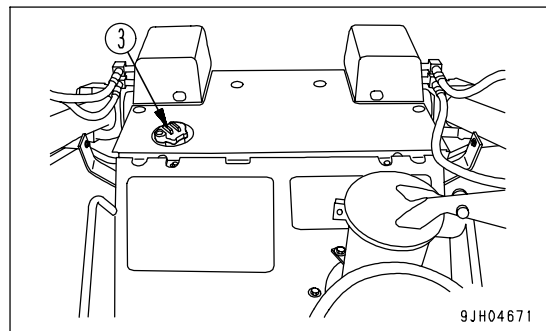

3. Prepare a container to catch the coolant, pull out hose (4) of the main radiator at the bottom front right of the machine, then open drain valve (5) and drain the water.
4. Open the drain valve (6) in the water pump piping on the right side of the engine, and drain the water.
5. After draining, close up drain valve (5), (6) and pour in clean water up to the vicinity of the water filler.
6. After the radiator is filled with water, start the engine and run it at low idle. After the water temperature rises above 90°C (194 °F), run the engine for approx. 10 minutes.
7. Stop the engine and open drain valve (5), (6) to drain the water.
8. After draining the water, clean the cooling system with cleaning agent.
For the cleaning method, see the instructions for the cleaning agent.

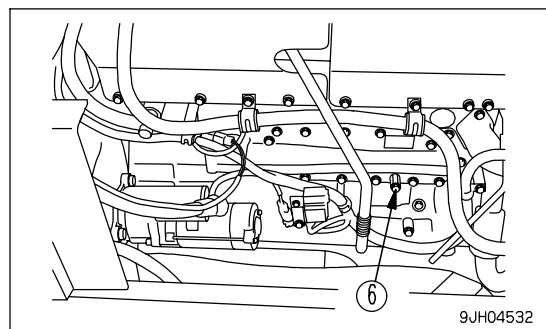
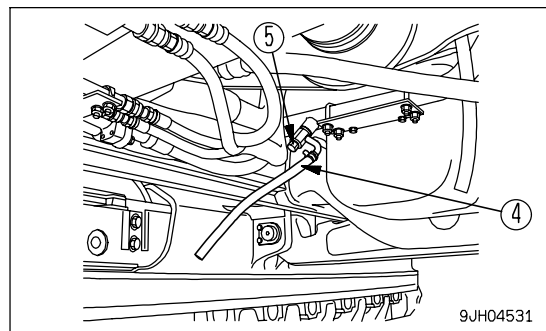

9. Replace the corrosion resistor, then open each valve (3).
 For details of the procedure for replacing the corrosion resistor, see "REPLACE CORROSION RESISTOR CARTRIDGE (PAGE 4-62)".
10. Close drain valve (5), (6).
11. Add coolant mixed with antifreeze until it overflows from the water filler.
 Decide the proportions of antifreeze and water according to the table for the mixing rate of water and antifreeze.
12. To remove air in the cooling system, run the engine for 5 minutes at low idle, then for 5 minutes at high idle.
 (While doing this, leave the radiator cap removed.)
13. Drain the coolant from sub-tank (7), clean the inside of the sub-tank, then add water until the coolant level is between the FULL and LOW marks.
14. Stop the engine, wait for approx. 3 minutes, then add coolant until the coolant level is near the coolant filler port, and tighten the cap (3). Check the coolant level and add coolant if necessary.

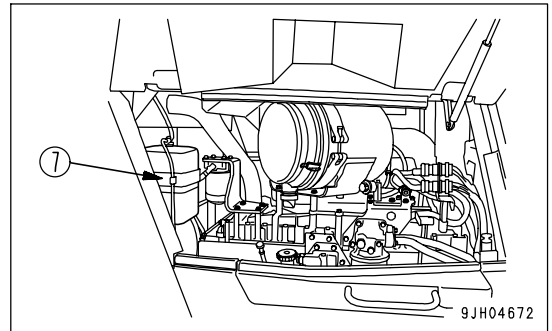

CHECK, CLEAN AND REPLACE AIR CLEANER ELEMENT

! WARNING

- Always wear protective glasses, dust mask, or other protective equipment.
- When removing the air cleaner element from the air cleaner body, it is dangerous to pull it out by force.
When working at high places or where the foothold is poor, be careful not to fall because of the reaction when pulling out the outer element.

CHECKING

If the internal yellow piston overlaps the red zone on the outside diameter of dust indicator (1), clean the air cleaner element. After cleaning, press the reset button to reset the piston.

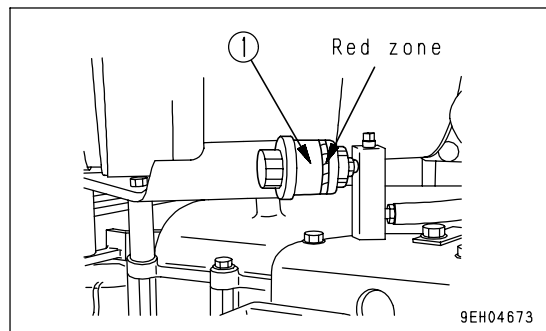

NOTICE

Always wait for the yellow piston in the dust indicator to overlap the red zone on the outside before cleaning the element.

If the element is cleaned frequently before the yellow piston in the dust indicator overlaps the red zone on the outside, the air cleaner will be unable to display its normal performance and the cleaning effect will become poor.

In addition, the frequency of dust stuck to the element falling inside the inner element during the cleaning operation will increase.

INSPECTION FOR MACHINES EQUIPPED WITH AIR CLEANER CLOGGING MONITOR

(If equipped)

If air cleaner clogging monitor (1) of the monitor panel flashes, clean the air cleaner element.

NOTICE

Do not clean the air cleaner element until the air cleaner clogging monitor on the monitor panel flashes. If the element is cleaned frequently before the clogging monitor flashes, the air cleaner will not be able to display its performance fully, and the cleaning efficiency will also go down.

In addition, during the cleaning operation, more dirt stuck to the element will fall inside the inner element.

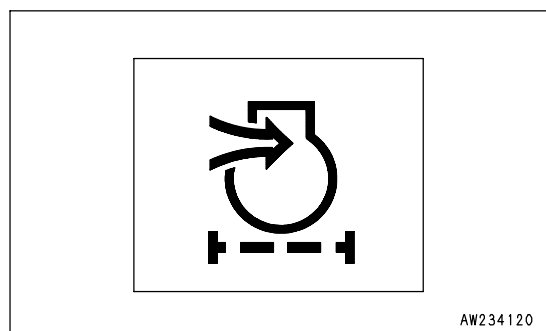
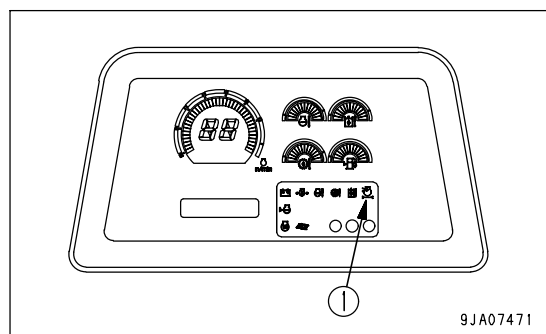

CLEANING OR REPLACING OUTER ELEMENT

NOTICE

Before and after cleaning the element, do not leave or keep it in direct sunlight.

1. Open the left engine side cover.
2. Remove three clips (2), then remove cover (3).

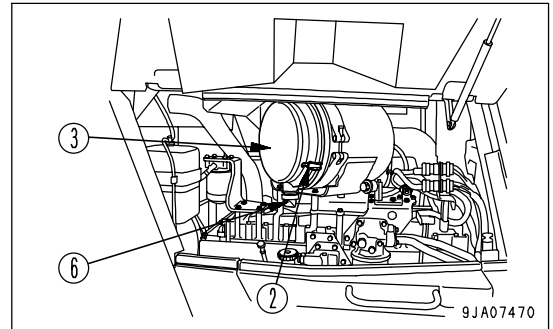

NOTICE

Never remove inner element (5). If it is removed, dust will enter and cause engine trouble.

3. Remove outer element (4).
4. Hold the outer element, rock it lightly up and down and to the left and right, and rotate the element to the left and right to pull it out.
5. Clean the interior of the air cleaner body, cover (3) and evacuator valve (6).

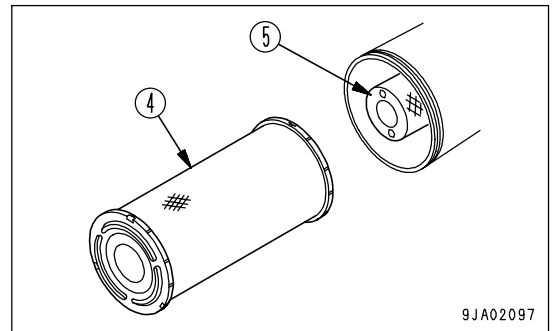

NOTICE

The inner element must not be used again even after cleaning. When replacing the outer element, replace the inner element at the same time.

6. Direct dry compressed air (Max. 0.69 MPa (7 kg/cm², 99.4 PSI)) from the inside of the outer element along its folds. Then direct the compressed air from the outside along the folds, and again from the inside.
 - 1) Check that the inner element is not loose. If it is loose, insert it securely.
 - 2) Replace any outer element which has been cleaned 6 times or used for 1 year. Replace the inner element at the same time.

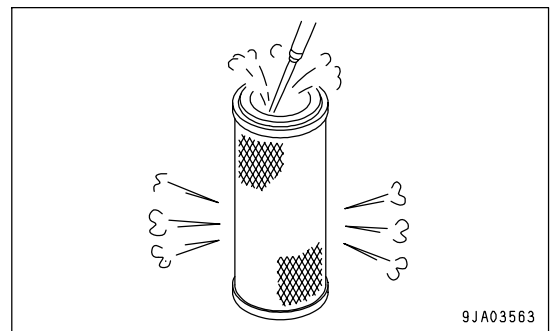

- 3) Even if the outer element has not been cleaned 6 times, if the yellow piston in the dust indicator goes to the 5 kPa position immediately after cleaning (when the engine is running at high idling, replace both the inner and the outer element.

7. If small holes or thinner parts are found on the element when it is checked by shining a light through it after cleaning, replace the element.

NOTICE

- When cleaning the element, do not hit or beat it against anything.
- Do not use an element whose folds or gasket or seal are damaged.

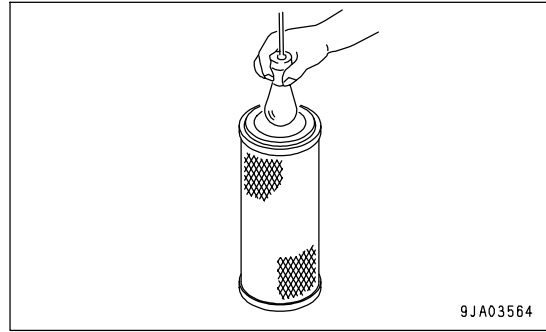

8. Before installing the outer element, check that the inner element is fitted securely. If the inner element is not fitted securely, push it in properly.

CAUTION

When installing the cover (3), check O-ring (7) and replace it if there are any scratches or damage.

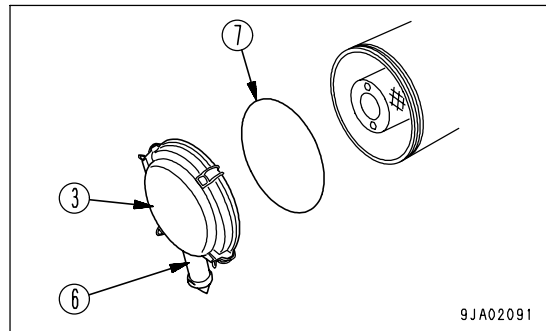

9. Set the cleaned outer element in position, then secure cover (3) with mounting clips (2).

10. Push the button of dust indicator (1) and return the yellow piston to its original position.

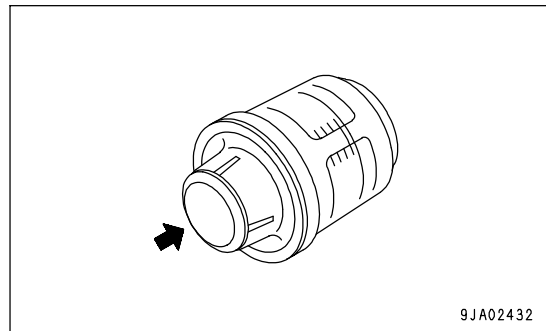

11. Close the left engine side cover.

REPLACING ELEMENT

1. Open the left engine side cover.
2. Remove three clips (2), then remove cover (3).

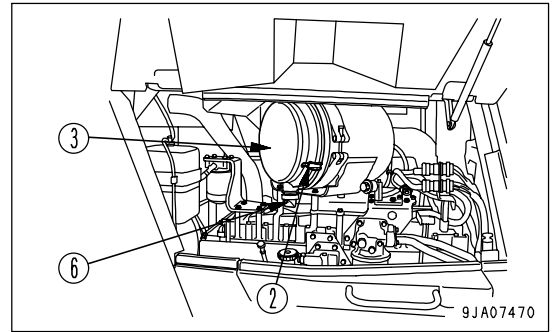

3. Remove outer element (4).
Do not remove inner element (5) at this time, however.
4. Clean the interior of the air cleaner body, cover (3) and evacuator valve (6).

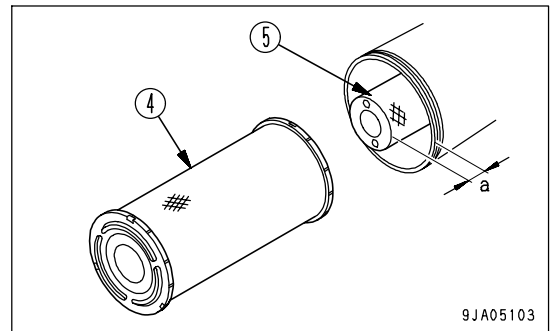

NOTICE

If the outer element and cover are installed when the inner element is not installed properly, the outer element may break.
When installation is correct, protrusion "a" of the inner element from the air cleaner body is 35 mm.

5. Remove inner element (5), then quickly install the new inner element.
Push the inner element in properly and check that it is fitted securely.
6. Set the new outer element (4) in position.
7. Replace O-ring (7) for cover (3) with new one.
8. Set the arrow mark on cover (3) at the top, install to the air cleaner body, then secure with clip (2).

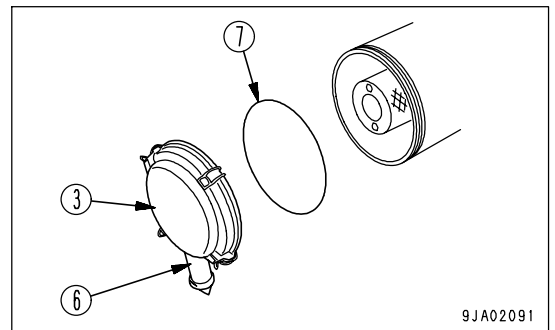

9. Push the button of dust indicator (1) and return the yellow piston to its original position.

REMARK

Immediately after a new element has been installed, the yellow piston of the dust indicator may go to the 2nd position, but this does not indicate any abnormality.

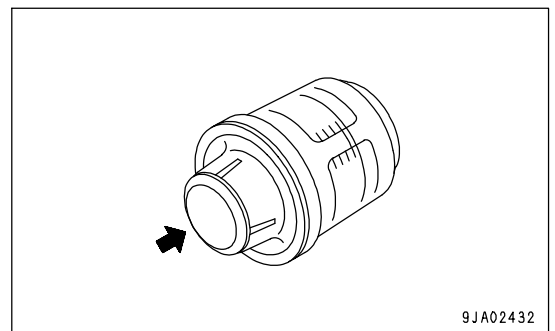

10. Close the left engine side cover.

CHECK AND ADJUST TRACK TENSION

The wear of pins and bushings on the undercarriage will vary with the working conditions and types of soil. It is thus necessary to continually inspect the track tension so as to maintain the standard tension.

Carry out the check and adjustment under the same conditions as when operating (on jobsites where the track becomes clogged with mud, measure with the track clogged with mud).

INSPECTION

Stop the machine on level ground (stop with the transmission in FORWARD without applying the brake). Then place a straight bar on the track shoes between the carrier roller and the idler as shown in the figure, and measure the clearance between the bar and the grouser at the midpoint. If the clearance (A) is 20 to 30 mm (0.79 to 1.18 in), the tension is standard.

If the track tension is not at the standard value, adjust it in the following manner.

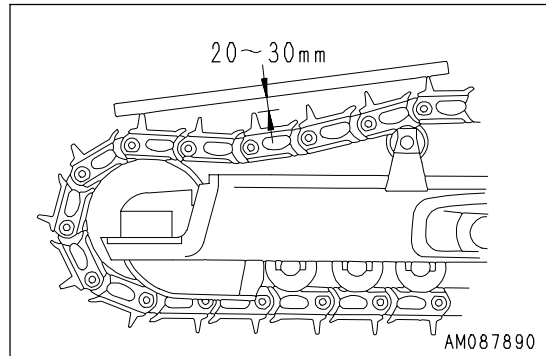

ADJUSTMENT

! WARNING

Grease inside adjusting mechanism is under high pressure. Grease coming from lubricator (1) under pressure can penetrate the body causing injury or death.

For this reason, do not loosen lubricator (1) more than one turn. Do not loosen any part other than lubricator (1). Furthermore, do not get any part of your body in front of the grease fitting.

If the track tension is not relieved by this procedure, please contact your Komatsu distributor.

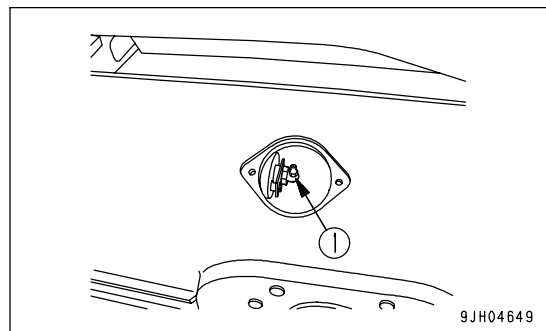

WHEN INCREASING TENSION

1. Pump in grease through grease fitting with a grease pump.
2. To check that the correct tension has been achieved, move the machine backwards and forwards.
3. Check the track tension again, and if the tension is not correct, adjust it again.
4. Continue to pump in grease until (S) becomes 0 mm. If the tension is still loose, the pin and bushing are excessively worn, so they must be either turned or replaced. Please contact your Komatsu distributor.

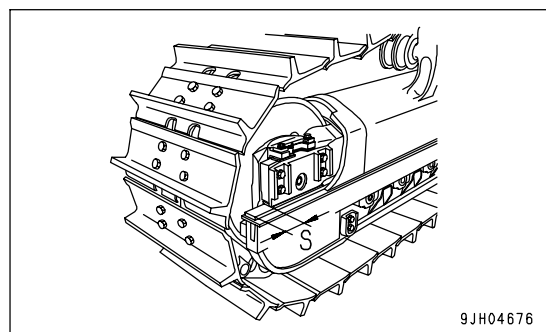

WHEN LOOSENING TENSION

**WARNING**

It is extremely dangerous to release the grease by any method except the procedure given below.
If track tension is not relieved by this procedure, contact your Komatsu distributor for repairs.

1. Loosen lubricator (1) gradually to release the grease.
2. When loosening lubricator (1), turn it a maximum of one turn.
3. If the grease does not come out smoothly, move the machine forwards and backwards a short distance.
4. Tighten lubricator(1).
5. To check that the correct tension has been achieved, move the machine backwards and forwards.
6. Check the track tension again, and if the tension is not correct, adjust it again.

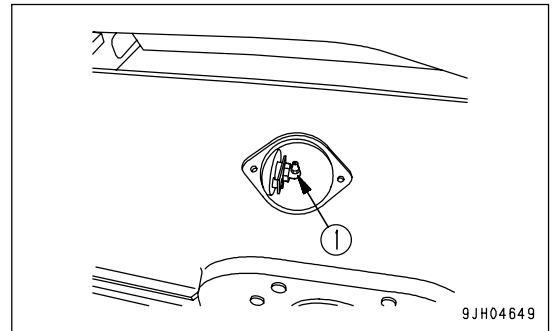

CHECK AND TIGHTEN TRACK SHOE BOLTS

If the machine is used with track shoe bolts (1) loose, they will break, so tighten any loose bolts immediately.

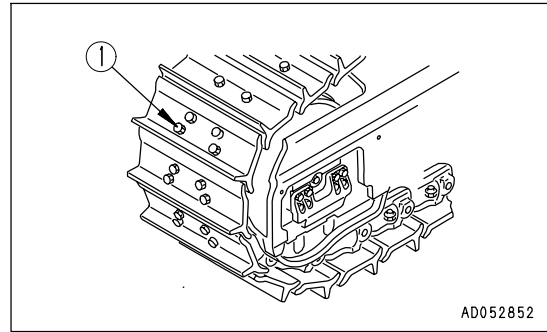
**METHOD OF TIGHTENING SHOE BOLT**

1. First, tighten to the tightening torque below, then check that the nut and shoe are in close contact with the link mating surface.
 - D85EX: 343 ± 39 Nm (35 ± 4 kgm, 253.2 ± 28.9 lbft)
 - D85PX: 539 ± 49 Nm (55 ± 5 kgm, 253.2 ± 28.9 lbft)
2. After checking, tighten a further $120^\circ \pm 10^\circ$.

METHOD OF TIGHTENING MASTER LINK CONNECTING BOLT

1. First tighten to a tightening torque of 343 ± 39 Nm (35 ± 4 kgm, 253 ± 29 lbft) then check that the link contact surfaces are in close contact.
2. After checking, tighten a further 160° to 180° .

ORDER FOR TIGHTENING

Tighten the bolts in the order shown in the diagram on the right.

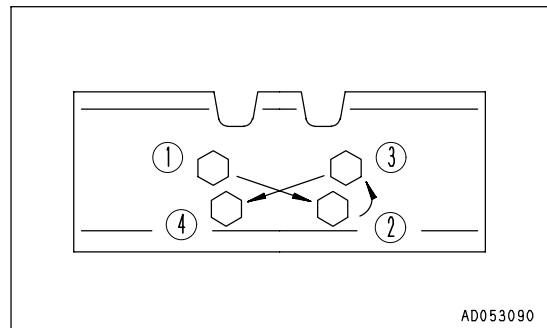

ADJUST IDLER CLEARANCE

The idler moves forward and backward under external pressure when this happens, side guide and guide plate become worn.

As they become worn, there is side play in the idler, or the idler turns at an angle, causing the track to come off or resulting in uneven wear, so adjust as follows.

ADJUSTING IN SIDEWAYS DIRECTION

1. Drive the machine for 8 to 12 m (24.4 to 36.6 ft) on flat ground, then measure clearance A (4 places: left, right, inside outside) between the track frame and side guide (1).
2. If clearance A is more than 4 mm (0.158 in), remove bolt (1), then take out shim, and adjust to that the clearance on one side is less than 0.5 to 1 mm (0.020 to 0.039 in).

REMARK

There are two types of shim (thickness: 0.5 mm (0.02 in) and 1.0 mm (0.04 in)).

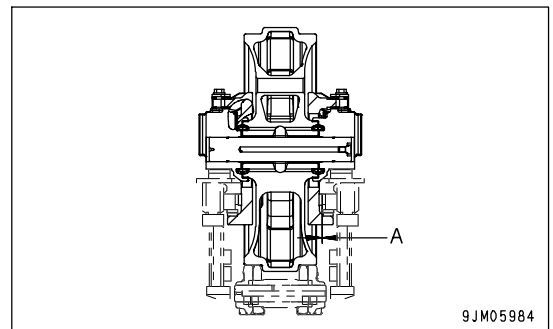
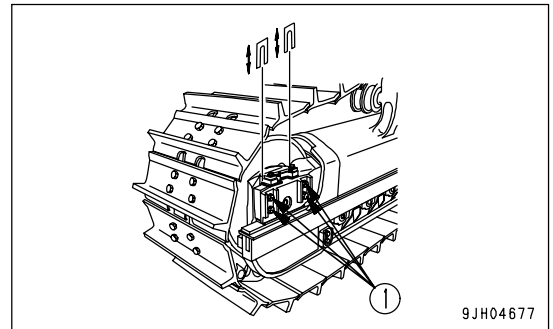

ADJUSTING IN VERTICAL DIRECTION

1. To determine the amount of adjustment, measure clearance B, then subtract 2 mm and record the result (amount of adjustment).

Example

If clearance B = 5 mm (0.197 in):

Amount of adjustment = 5 - 2 = 3 mm (0.118 in)

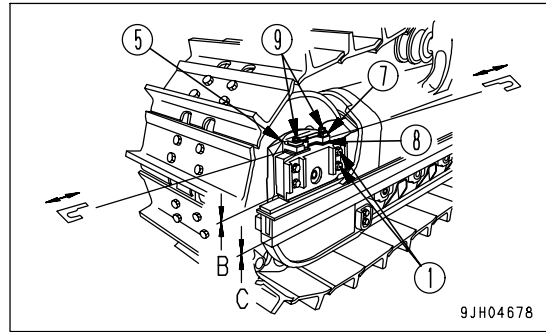

2. Loosen bolts (9) (inside, outside: Total 4) to a point where there is no more reaction from the spring.
3. Loosen bolt (1) (inside, outside: Total 8) . When doing this, do not loosen it more than 3 turns.
4. Using a bar, pull up up-down guide (5) to set clearance C to 0, then remove shims of a thickness equal to the amount of adjustment measured in Step 1.
5. After removing shims (7), add them on top of shim (8).

(Left, right, inside, outside: Total 8 places)

When doing this, check that the total thickness of shim (7) and shim (8) is the same after adjustment as it was before adjustment at all places.

Discarding shims or adding shims will result in improper function of the built-in spring.

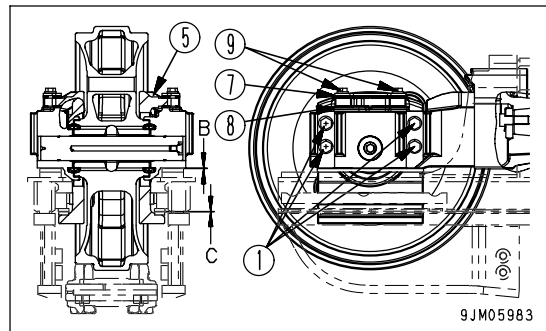

REMARK

There are two types of shim thickness: 1 mm (0.039 in) and 2 mm (0.079 in).

REVERSE AND REPLACE THE END BITS AND CUTTING EDGES

 **WARNING**

It is dangerous if the work equipment moves by mistake when the cutting edges and end bits are being reversed or replaced. Set the work equipment in a stable condition, then stop the engine and lock the blade control lever securely with the work equipment lock lever.

Reverse or replace the end bits and cutting edges before it is worn out to the blade end.

1. Raise the blade to a proper height, position a block under the frame to prevent the blade from falling.
2. Operate the work equipment lock lever to the LOCK position.
If the cutting edge and the end bit on both sides are worn out, replace with new one.
If the mounting surface is worn, correct it before turning or replacing the end bits.

3. Loosen nut (1) and remove bolt (2). Then remove the cutting edge and the end bit and clean the mounting surface.
4. Reverse or replace the cutting edge and the end bit when worn out.
If bolt (1) and nut (2) are damaged, replace them with new ones at the same time.

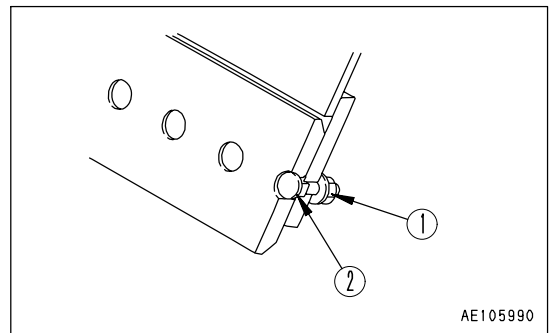

5. Install the edge to the blade, then tighten partially. Drop the blade three to five times on to the ground or rock to remove any play in bolt (2), then tighten it to the correct tightening torque. When installing end bit (3), put top surface (4) of the end bit in close contact with stopper (5), then tighten with the bolts.

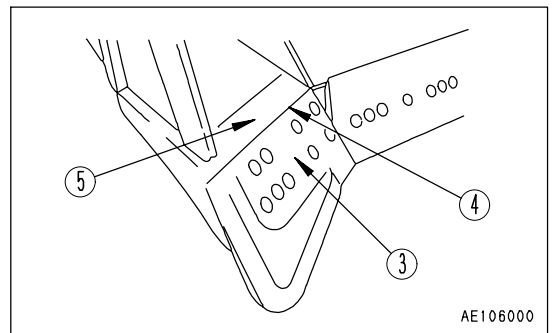

Tightening torque: 628 ± 79 Nm (64 ± 8 kgm, 462 ± 57.9 lbft)

6. After several hours of running, retorque the nuts.

CLEAN, CHECK RADIATOR FINS AND OIL COOLER FINS

Carry out this procedure if there is any mud or dirt stuck to the radiator or oil cooler.

REMARK

Check the hydraulic cooler hoses. If any hose is cracked or hardened by age, replace with a new hose. Also check and tighten all loose hose clamps.

CLEANING BY ROTATING COOLING FAN IN REVERSE DIRECTION

NOTICE

When rotating the cooling fan in the reverse direction, be extremely careful of flying dust.

When stopping the engine when the cooling fan is rotating in the reverse direction, first run the engine at low idling, then stop it.

The dust and dirt stuck to the radiator and cooler can be blown out by rotating the cooling fan in the reverse direction.

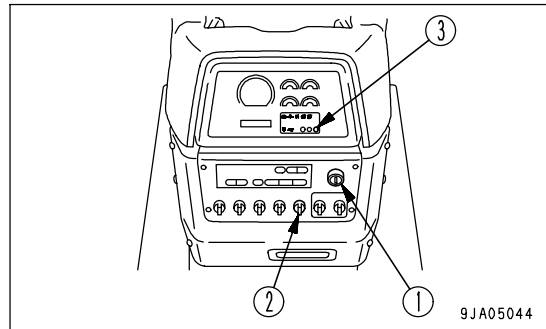

1. Turn starting switch (1) to the "OFF" position and stop the engine.
2. Turn starting switch (1) to the "ON" position.
3. Set fan rotation selector switch (2) to the cleaning position (CLN:(C)).

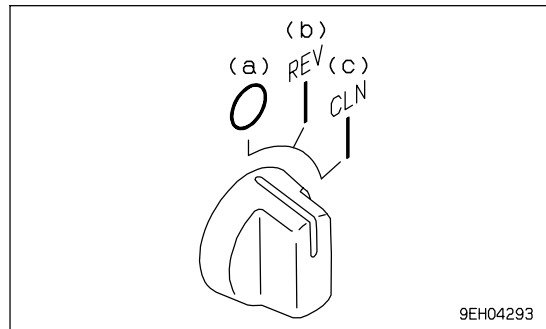

REMARK

If the engine is running, the direction of rotation of the fan will not change even when the fan rotation selector switch is operated. Fan operation confirmation lamp (3) will flash to inform the operator that the direction of rotation of the fan has not been switched. Stop the engine, then start it again. The direction of rotation of the fan will be switched.

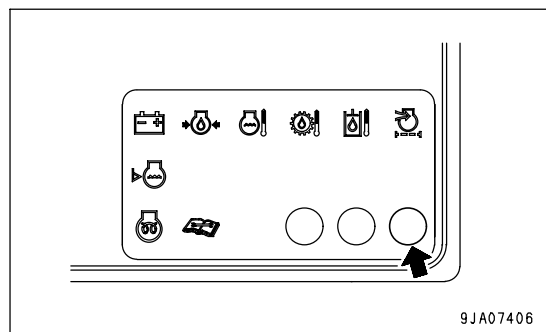

4. Turn starting switch (1) to the START position and start the engine. The cooling fan will rotate in the reverse direction.
5. Run the engine at high idle.
 - Select the time for running the engine at high idle as follows according to the condition of clogging.
 - Normal clogging: 1 to 2 minutes
 - Excessive clogging: 2 to 3 minutes
6. After completing the cleaning, run the engine at low idle for approx. 10 seconds.
7. Turn starting switch (1) to the "OFF" position and stop the engine.

8. Turn starting switch (1) to the "ON" position.
9. Turn the fan rotation selector switch (2) to the normal rotation position (a) and cancel the reverse rotation.

REMARK

If dirt is caught in the radiator fins, blow with compressed air to clean.

CLEANING WITH COMPRESSED AIR

 **WARNING**

- Directing compressed air, pressurized water, or steam directly at your body, or using these and causing dust to fly may cause personal injury. Always wear protective glasses, anti-dust mask, and other protective equipment.
- When carrying out cleaning, always stop the engine and check that the fan is not rotating. If you touch the fan when it is rotating, it will cause serious personal injury.

1. Remove bolts (1) at the four corners of the radiator grill, then open radiator grill (2).
2. Clean the radiator fins clogged with mud, dust and leaves with compressed air. Steam or water may be used instead of compressed air.

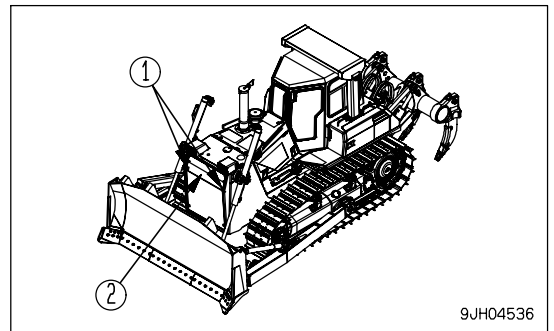

3. Use compressed air to remove the mud, dirt, and leaves clogging the hydraulic cooler fins. Steam or water may be used instead of compressed air.

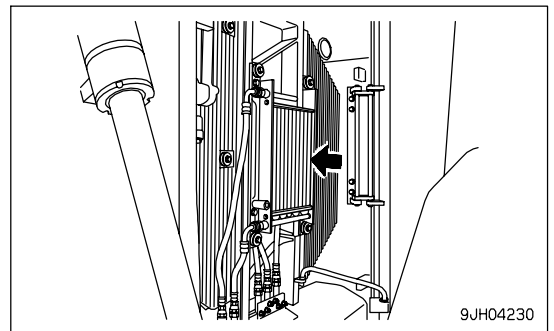

REMARK

Check the hydraulic cooler hoses. If any hose is cracked or hardened by age, replace with a new hose. Also check and tighten all loose hose clamps.

CLEAN FUEL TANK STRAINER

Clean the strainer if there is any dirt collected in it.

Remove the filler cap (1) of the fuel tank and take out strainer.

If the strainer is dirty, clean it with diesel fuel.

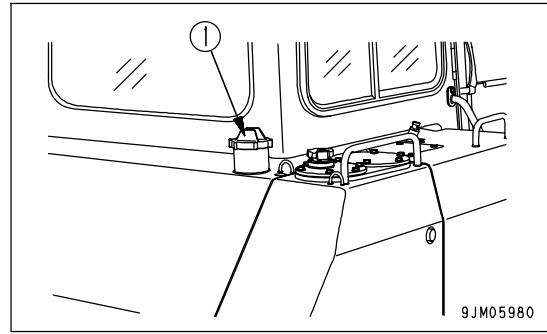

9JM05980

DRAIN WATER AND SEDIMENT IN FUEL TANK

Carry out this procedure after the machine has been at rest for a long time and after a long spell of rainy days.

- Prepare a container to catch the fuel that is drained.
- 1. Open drain valve(1) at the bottom of the tank to drain sediment and water accumulated on the bottom, together with fuel.
At this time, take care not pour fuel over yourself.
- 2. When clear fuel comes out, close drain valve (1).

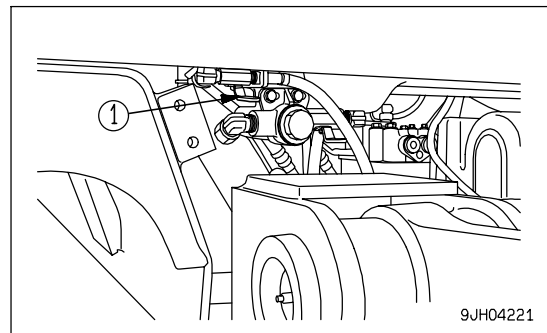

9JH04221

CLEAN STEERING CLUTCH CASE BREATHER

1. Open the valve cover.
2. Remove the bolts, then remove cover (1).
3. Remove breather (2) at the side of the hydraulic tank, remove the dirt stuck to the breather, then wash it in clean diesel oil or flushing oil.

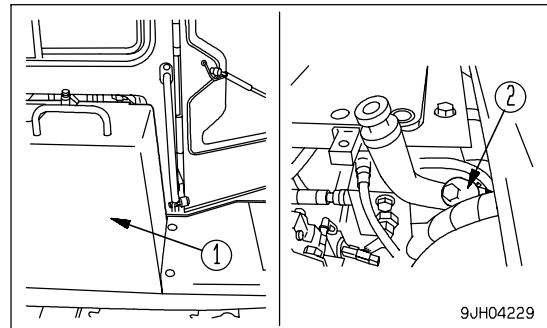

9JH04229

CHECK UNDERCARRIAGE OIL



WARNING

If the oil level in the idler is low, new oil must be added, and the machine body must be inclined in this case. Since this work is dangerous, ask your Komatsu distributor.

REMARK

At the idler portion, seal bolt (1) cannot be seen if the side outer cover is not removed.

Stop the machine on level ground, and check for any reduction in the oil at the idler (portion P), track roller (portion Q), and carrier roller (portion R).

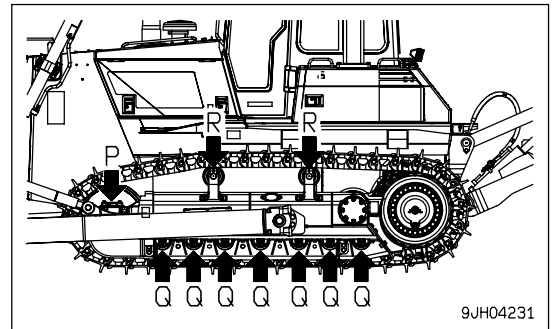

1. Loosen seal bolt (1) slowly and check if oil oozes out from the thread. If oil oozes out, the oil level has not gone down, so tighten the bolt.
2. If no oil comes out even when seal bolt is removed, the oil level is low. Contact your Komatsu distributor for repairs.

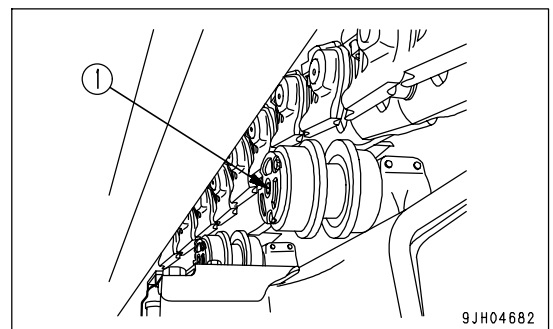
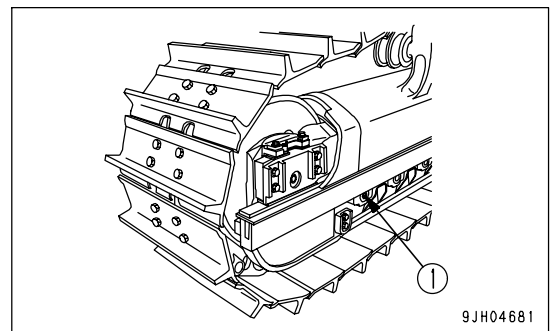
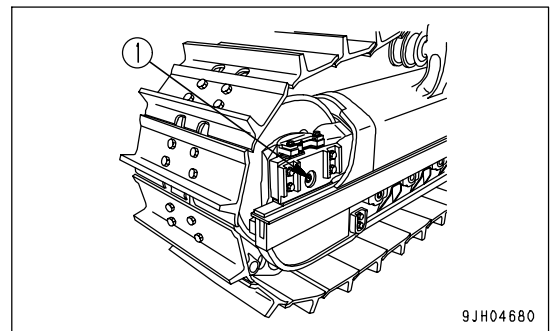

CLEAN AIR CONDITIONER AIR FILTER (FRESH/RECIRC FILTER)

Clean the air conditioner air filter if it becomes clogged or if there is dirt or oil stuck to it.

In places where there is a lot of dust, clean the air filter once a week. In addition, clean the air conditioner air filter at the same time, when cleaning the engine air cleaner.

1. Open inspection cover (1) on top of the hood, then remove pressure air filter (2).
2. Open inspection cover (3) under the front panel and pull up recirculation air filter (4) to remove it.
3. Clean filters (2) and (4) with compressed air. If there is oil stuck to the filter, or it is extremely dirty, wash it in a neutral agent. After washing it, dry it completely before installing it again.

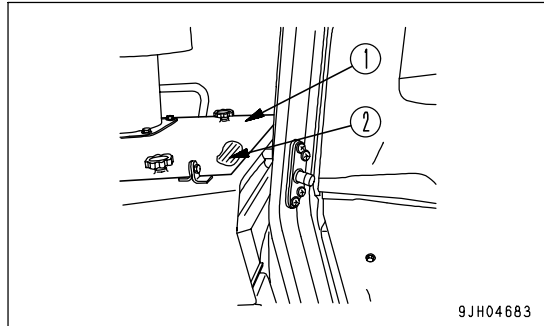

REMARK

If the filters cannot be cleaned with air or in water, replace them with new ones.

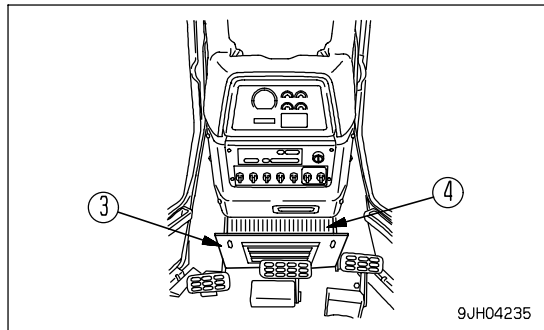

CHECK AND ADJUST AIR CONDITIONER

CHECK TENSION OF COMPRESSOR BELT

If the belt is loose, it will slip and the cooling effect will be reduced. From time to time, press a point midway between the drive pulley and compressor pulley with your finger (approx. 58.8 N {6 kg}) and check that the tension is 15 to 18 mm (0.6 to 0.7 in). When the belt is new, there will be initial elongation, so always adjust again after 2 or 3 days.

REMARK

If the V-belt has stretched and there is no more allowance for adjustment, replace the V-belt.

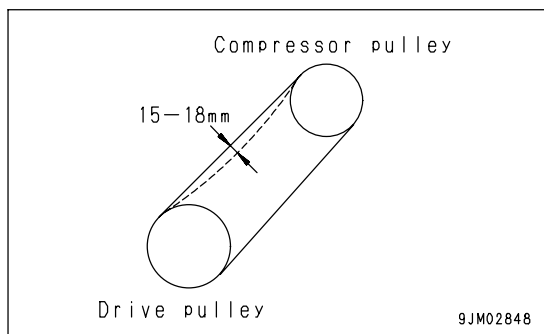

REPLACE BELT

1. Loosen 4 bolts (1) and jack bolt (2), then move compressor (3) to the side.
2. Replace the V-belt.
 - When adjusting the V-belt, do not push the compressor directly with the bar. Use jack bolt (2).
3. Tighten jack bolt (2) and bolts (1), and apply tension to the V-belt. The standard deflection for the belt is approx. 10 mm (0.4 in) when pressed with a finger force of approx. 58.8N (6 kg) at a point midway between the air conditioner compressor pulley and fan pulley.

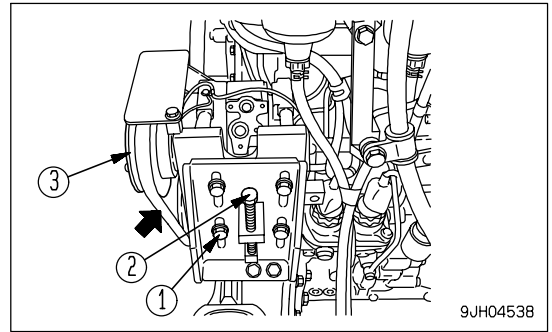

CHECK LEVEL OF REFRIGERANT(GAS)

! WARNING

If the refrigerant used in the air conditioner gets into your eyes or on your hands, it may cause loss of sight or frostbite. Do not touch the refrigerant. Never loosen any part of the refrigerant circuit. Do not bring any flame close to any point where the refrigerant gas is leaking.

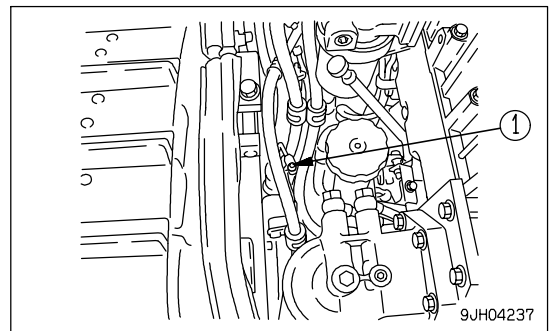

If the level of the refrigerant (gas) is low, the cooling effect will be reduced. Run the engine at high idling, and check the flow of the refrigerant in the refrigerant circuit through the sight glass of the receiver (1) when the cooler is running at high speed.

- No bubbles in refrigerant flow: Suitable
- Some bubbles in flow (bubbles pass continuously): Lack of refrigerant
- Colorless, transparent: No refrigerant

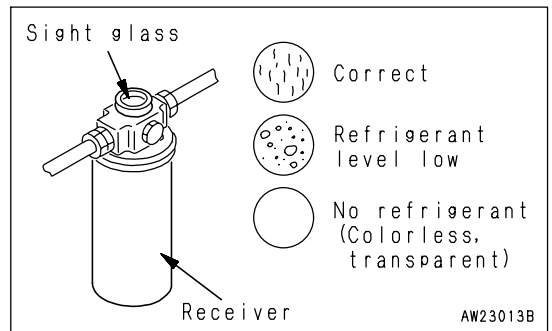

REMARK

- When there are bubbles, the refrigerant gas level is low, so contact your refrigerant dealer to have refrigerant added. If the air conditioner is run with the refrigerant gas level low, it will cause damage to the compressor.
- New R134a is used as the refrigerant.

OPERATING AIR CONDITIONER OFF-SEASON

Even during the off-season, operate the air conditioner for 3 to 5 minutes once a month to maintain the oil film at all parts of the compressor.

LUBRICATE DOOR HINGE

If the door makes a squeaking noise when it is opened or closed, spray lubricant in through the split in the hinge bushing. If the bushing is worn, replace the hinge.

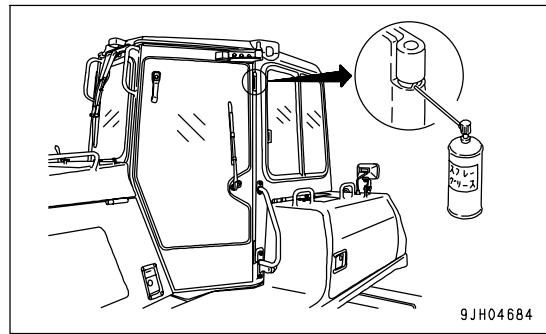

CHECK DOOR LATCH

WARNING

If the control lever is touched by accident during checking, the machine moves off suddenly, and this may lead to serious injury or death. Before checking door latch, stop the engine and set the parking brake lever securely to the LOCK position.

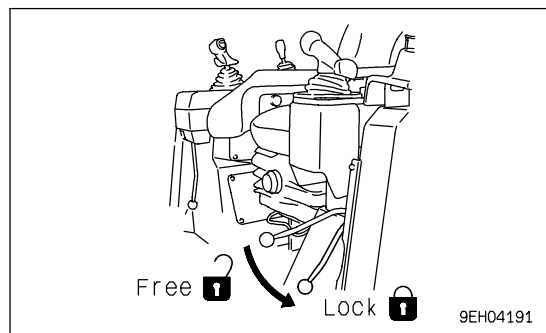

Check

Hold the door open-locked, and check that there is still grease inside the latch. If the amount of grease is low or there is no more grease, coat the inside of the latch with grease from portion (1).

REMARK

If there is no more grease inside the latch, the movement will become poor because of dust inside the latch, and the handle may be stiff when opening the door.

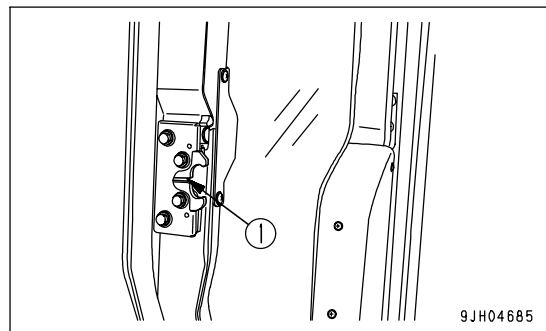

CHECK DOOR LOCK STRIKER

If the wear of the door lock striker exceeds 0.5 mm (0.02 in), replace the striker. If it is used at it is, the play will increase and this may result in breakage of the hinge or door lock.

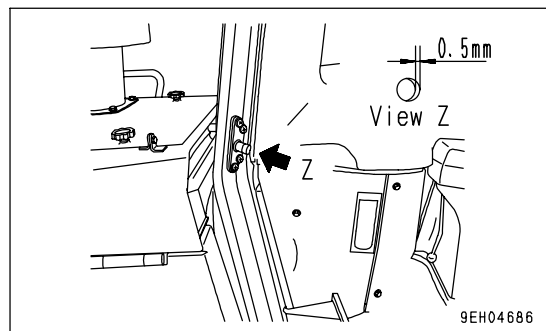

REPLACE DOOR DAMPER

If the depth of the door damper rubber groove is less than 2 mm (0.08 in), replace the damper.

There are four dampers each at the top and bottom on the left and right doors.

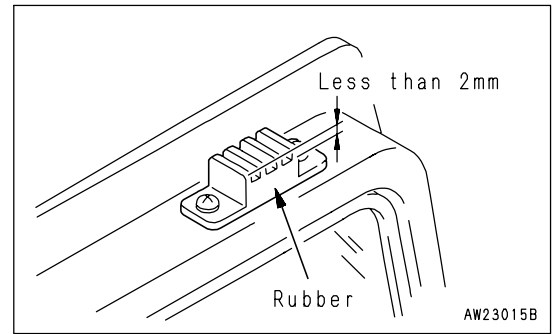

CHECK WINDOW WASHER FLUID LEVEL, ADD FLUID

If there is air in the window washer fluid, check the level and add fluid.

Open the battery cover, check the level of the fluid in window washer tank (1), and if it is low, add automobile window washer fluid.

When adding fluid, be careful not to let any dust get in.

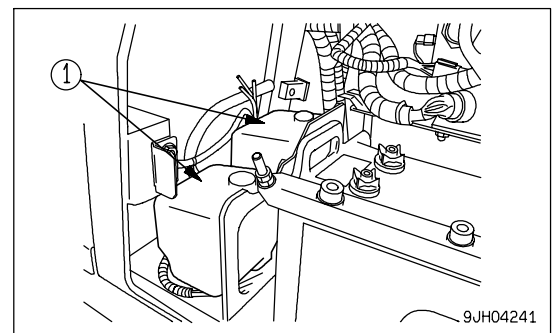

PROPORTION FOR MIXING FLUID WITH WATER

The proportion differs according to the ambient temperature, so dilute the washer fluid with water to the following proportions before adding.

Area, season	Proportions	Freezing temperature
Normal	Washer fluid 1/3: water 2/3	-10°C (14°F)
Winter in cold area	Washer fluid 1/2 : water 1/2	-20°C (-4°F)
Winter in extremely cold area	Pure washer fluid	-30°C (-22°F)

There are two types depending on the freezing temperature:

-10°C (14°F) (general use) and -30°C (-22°F) (cold area use), select according to the area and season.

REPLACE WIPER BLADE

If the blade is damaged, it will not wipe the window clean, so replace the blade.

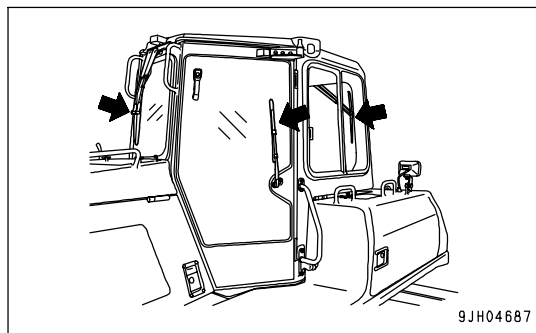

REPLACEMENT

FRONT, REAR WIPER

1. It is hooked at portion (A), so move the blade in the direction of the arrow to remove it.
2. Install the new blade and hook it securely.

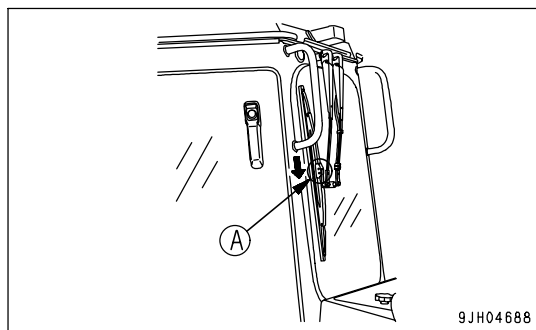

REAR WIPER

1. Remove E-ring (1).
The blade can then be removed.
2. Install a new blade, then install securely with E-ring (1).

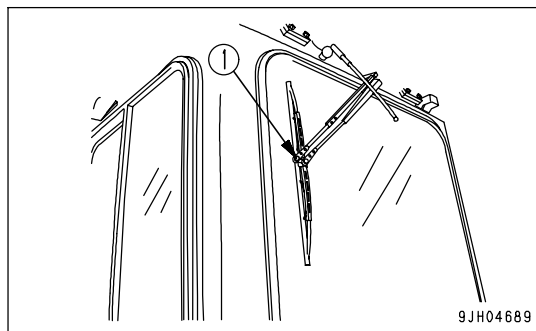

DOOR WIPER

1. It is hooked at portion (A), so move the blade in the direction of the arrow to remove it.
2. Install the new blade and hook it securely.

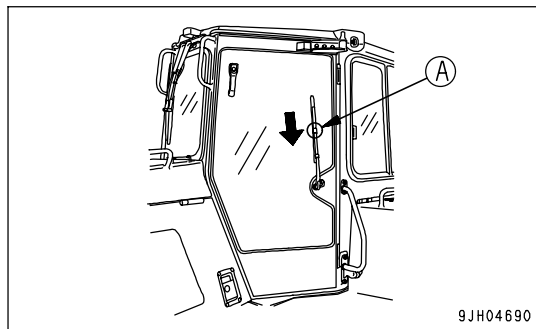

BLEEDING AIR IN HYDRAULIC SYSTEM

See "OPERATIONS AND CHECKS AFTER STARTING ENGINE (PAGE 3-100)".

Since the engine must be started and the blade must be operated, see OPERATION.

NOTICE

If the engine is run at high speed immediately after startup or a cylinder is pushed up to its stroke end, air taken inside the cylinder may cause damage to the piston packing.

1. Bleeding air from cylinders

- 1) Run the engine at low idle, and extend and retract each cylinder 4 to 5 times, taking care that a cylinder is not moved to the end of its stroke. (Stop the cylinder approx. 100 mm (3.9 in) short of its stroke end)
- 2) Next, operate each cylinder 3 to 4 times to the end of its stroke.
- 3) Finally, operate each cylinder 4 to 5 times to the end of its stroke to completely remove the air.

CHECK ELECTRICAL INTAKE AIR HEATER

Check before the cold season starts (once a year).

Remove the electric heater from the engine intake manifold and check for wire disconnections and dirt clinging to it.

When checking and installing the electric heater, replace its gasket with a new one.

LUBRICATING

1. Lower the work equipment to the ground, then stop the engine.
2. Using a grease pump, pump in grease through the grease fittings shown by arrows.
3. After greasing, wipe off any old grease that was pushed out.

Fuel control (1 place)

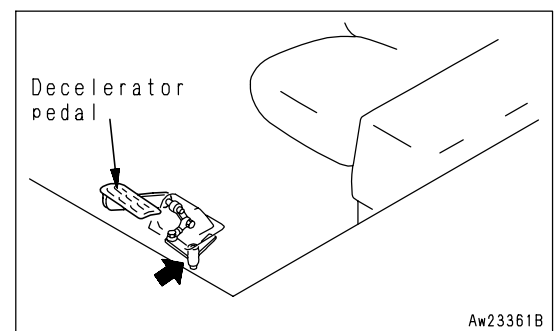

CHECK BEFORE STARTING

For details of the following items, see "CHECK BEFORE STARTING (PAGE 3-78)".

- Check oil level in engine oil pan, add oil
- Check coolant level, add coolant
- Check dust indicator
- Check water separator, drain water and sediment
- Check oil level in power train case, add oil
- Check oil level in hydraulic tank, add oil
- Check electric wiring
- Checking with machine monitor
- Check fuel level, add fuel
- Check brake pedal travel
- Check that lamps light up
- Check horn sound
- Check backup alarm sound

EVERY 250 HOURS SERVICE

LUBRICATING

1. Lower the work equipment to the ground, then stop the engine.
2. Using a grease pump, pump in grease through the grease fittings shown by arrows.
3. After greasing, wipe off any old grease that was pushed out.

(1) Blade lift cylinder support yoke (4 places)

REMARK

These are at the front and rear of the left and right cylinders.

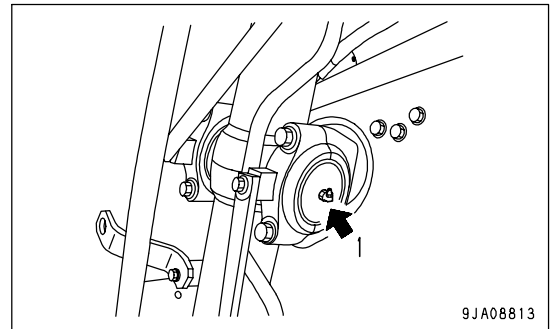

(2) Blade lift cylinder support shaft (2 places)

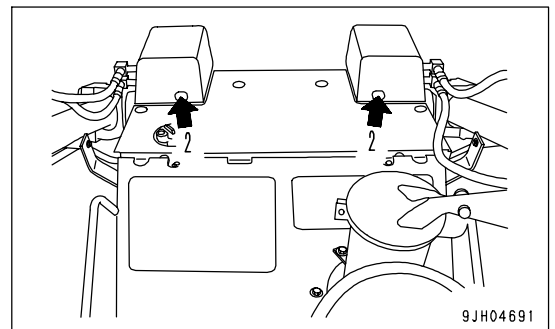

(3) Blade arm ball joint (4 places)

(4) Brace screw (2 places)

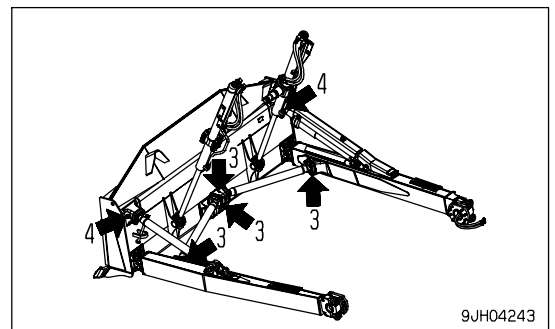

(5) Ripper lift cylinder bottom pin (2 places)

(6) Ripper lift cylinder rod end pin (2 places)

(7) Ripper arm pin (front) (6 places)

(8) Ripper arm pin (rear) (6 places)

- (5) - (8) indicate the greasing points for the fixed multi-shank ripper specification.

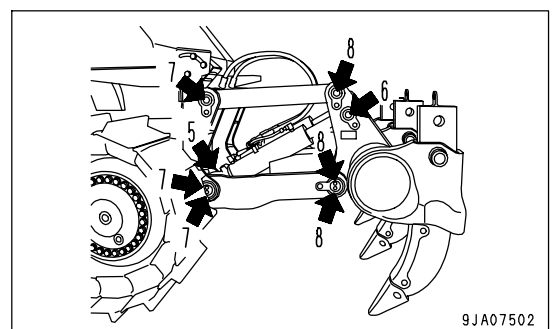

- (9) Ripper arm pin (front) (2 places)
- (10) Ripper arm pin (rear) (2 places)
- (11) Lift cylinder bottom pin (2 places)
- (12) Lift cylinder head pin (2 places)
- (13) Tilt cylinder bottom pin (2 places)
- (14) Tilt cylinder head pin (2 places)

- (9) - (14) indicate the greasing points for the variable multi-shank ripper specification.

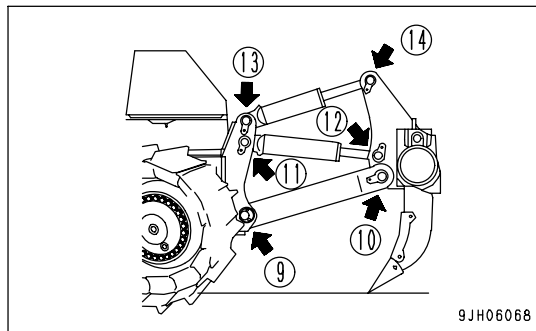

- (15) Equalizer bar side shaft (2 places)

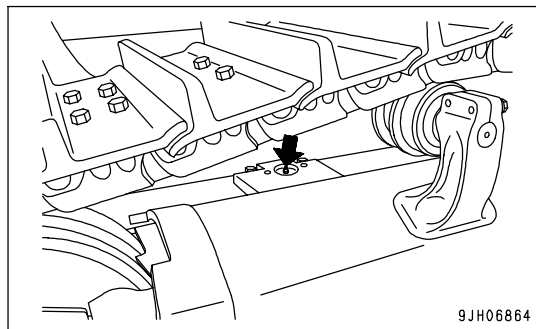

- (16) Suspension (Equalizer bar center shaft) (1 place)

- 1) Carry out greasing of the suspension (equalizer bar center shaft) through the grease fittings marked by arrows.
- 2) Pump the greasing lever up and down 3 to 5 times.

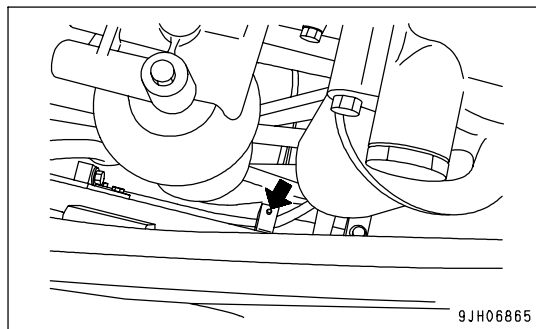

CHECK ALTERNATOR DRIVE BELT TENSION, ADJUST

CHECKING

The standard deflection for the drive belt is approx.13 to 16 mm (0.51 to 0.63 in) when pressed by thumb (approx 99.1N {10 kg}) at a point midway between the drive pulley and alternator pulley.

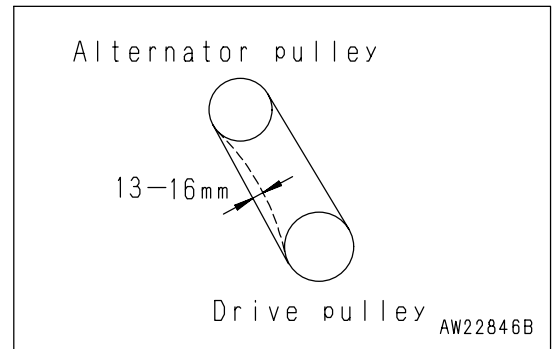

ADJUSTING

1. Loosen bolts (1) and nuts (2), (4), and (5), then turn nut (4) and adjust the belt tension.
2. After adjusting, tighten bolts and nuts (2), (4), and (5), to secure alternator (3) in position.

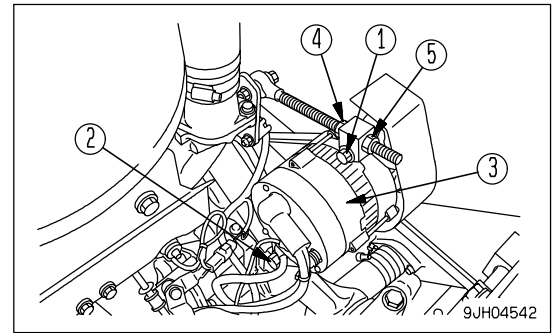

REMARK

- Check each pulley for breakage and wear of the V-groove. In particular, check that the V-belt does not touch the bottom of the V-groove.
- If any abnormality is found, ask your Komatsu distributor for replacement of the pulley.
- If the V-belt is so lengthened that it cannot be adjusted any more or if it has any cuts or cracks, replace it.
- When adjusting the V-belt, do not press the alternator directly with a bar, but put a wood piece, etc. in-between them.
- If the V-belt has been replaced with a new part, there will be initial elongation, so inspect and adjust it again after one-hour of operation.

CHECK LEVEL OF BATTERY ELECTROLYTE

Carry out this procedure before operating the machine.

**WARNING**

- Do not use the battery if the battery electrolyte level is below the LOWER LEVEL line. This will accelerate deterioration of the inside of the battery and reduce the service life of the battery. In addition, it may cause an explosion.
- The battery generates flammable gas and there is danger of explosion, do not bring fire or sparks near the battery.
- Battery electrolyte is dangerous. If it gets in your eyes or on your skin, wash it off with a large amount of water and consult a doctor.
- When adding distilled water to the battery, do not allow the battery electrolyte to go above the UPPER LEVEL line. If the electrolyte level is too high, it may leak and cause damage to the paint surface or corrode other parts.

NOTICE

If there is a fear that the battery water may freeze after refilling with purified water (e.g. commercially available replenishment water for a battery), do the replenishment before the day's work on the next day.

Inspect the battery electrolyte level at least once a month and follow the basic safety procedures given below.

Open battery cover on the left side of the machine.

WHEN CHECKING ELECTROLYTE LEVEL FROM SIDE OF BATTERY

If it is possible to check the electrolyte level from the side of the battery, check as follows.

1. Use a wet cloth to clean the area around the electrolyte level lines and check that the electrolyte level is between the UPPER LEVEL (U.L.) and LOWER LEVEL (L.L.) lines.
If the battery is wiped with a dry cloth, static electricity may cause a fire or explosion.

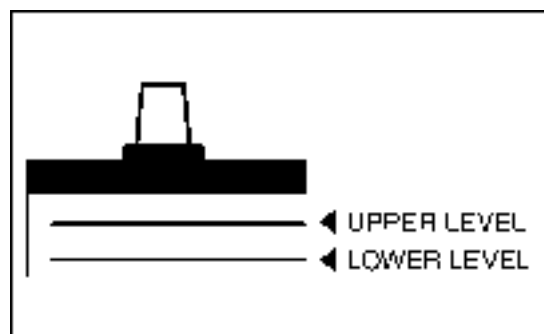

2. If the electrolyte level is below the midway point between the U.L and L.L lines, remove cap (1) and add distilled water to the U.L line.
3. After adding distilled water, tighten cap (1) securely.

REMARK

If distilled water is added to above the U.L. line, use a syringe to lower the level to the U.L. line. Neutralize the removed fluid with baking soda (sodium bicarbonate), then flush it away with a large amount of water or consult your Komatsu distributor or battery maker.

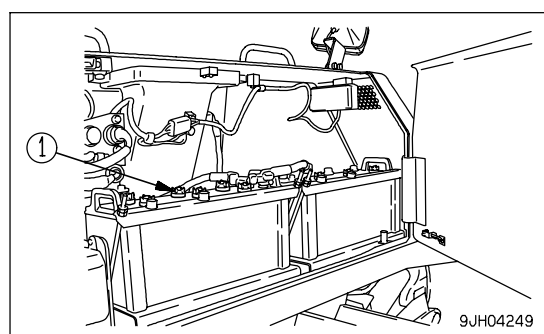

WHEN IT IS IMPOSSIBLE TO CHECK ELECTROLYTE LEVEL FROM SIDE OF BATTERY

If it is impossible to check the electrolyte level from the side of the battery, or there is no display of the UPPER LEVEL line on the side of the battery, check as follows.

1. Remove cap (1) on the top of the battery, look through the water filler port, and check the electrolyte surface. If the electrolyte does not reach the sleeve, add distilled water so that the level reaches the bottom of the sleeve (UPPER LEVEL line) without fail.

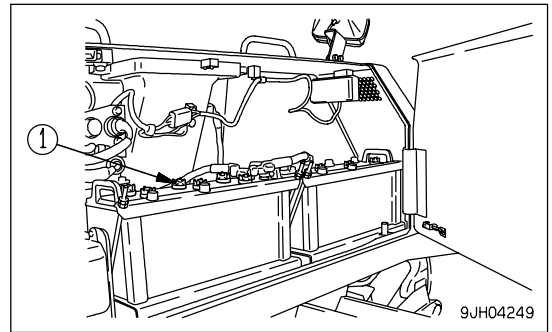

Use the diagram below for reference, and check if the electrolyte reaches the bottom of the sleeve.

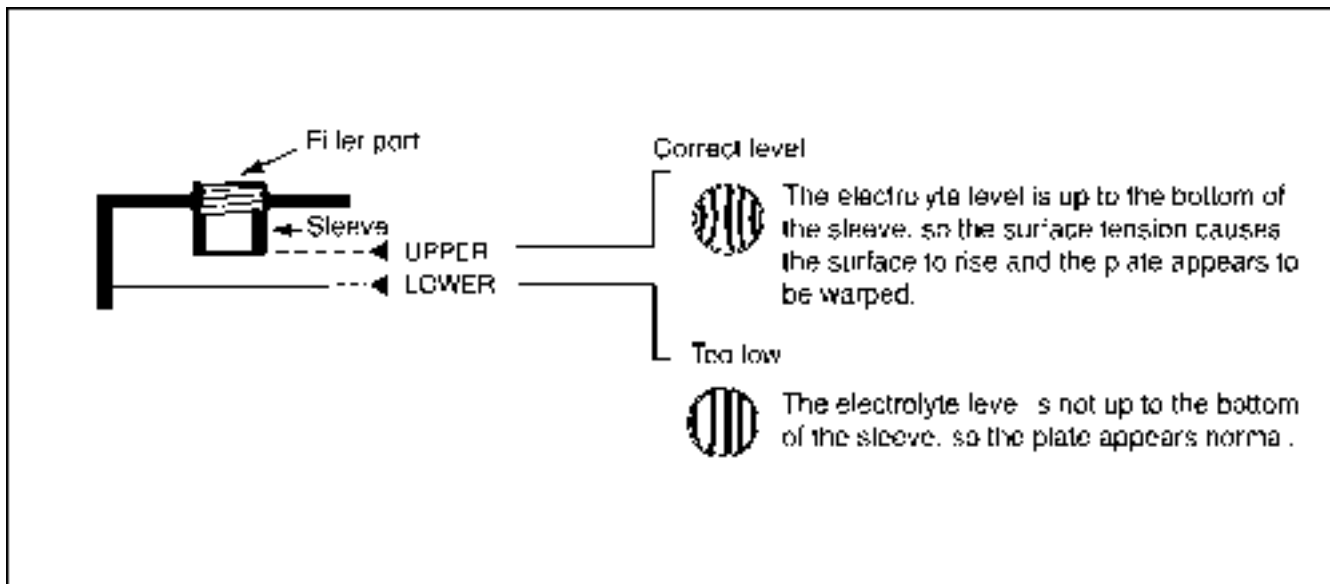

2. After adding distilled water, tighten cap (1) securely.

REMARK

If water is added to above the bottom tip of the sleeve, use a pipette to remove electrolyte. Neutralize the removed electrolyte with sodium bicarbonate, then flush it away with a large amount of water. If necessary, contact your Komatsu distributor or your battery maker.

WHEN IT IS POSSIBLE TO USE INDICATOR TO CHECK ELECTROLYTE LEVEL

If it is possible to use an indicator to check the electrolyte level, follow the instructions given.

CHECK BRAKE PERFORMANCE

**WARNING**

If the machine moves during the following operation, please contact your Komatsu distributor for repairs immediately.

NOTICE

Do not place the joystick in the 1st speed position.
Otherwise, it will cause damage to the machine.

Before starting the engine, check that the area around the machine is safe, then do as follows:

1. Start the engine.
2. After completing the warm-up operation, set fuel control dial (3) to the SLOW position.
3. Set work equipment lock lever (1) to the FREE position then operate blade control lever (6) and ripper control lever (7) to raise the blade and ripper.
Leave the work equipment lock lever (1) in the FREE position.
4. Set parking brake lever (2) to the FREE position.
5. Depress brake pedal (5), set joystick (4) in FORWARD, then press the shift up button to enter 2nd speed.
6. Operate fuel control dial (3) and gradually raise the engine speed to full throttle. (Keep the brake pedal depressed.)
7. Check that the machine does not move. This indicates that brake performance is normal.

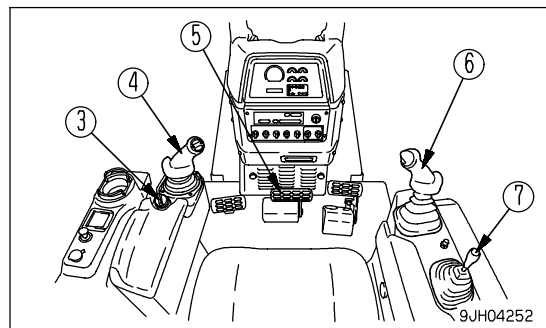
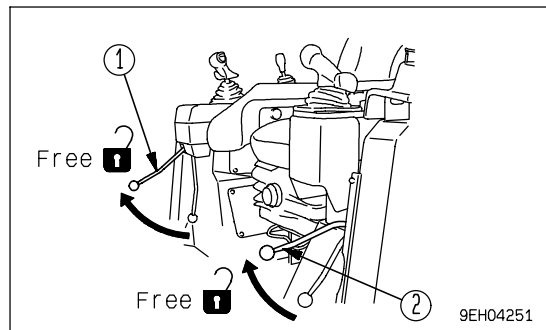

CHECK OIL LEVEL IN DAMPER CASE, ADD OIL

1. Open the engine side cover on the left side of the chassis.
2. Remove dipstick (G) and wipe the oil off with a cloth.
3. Fully insert dipstick (G) into filler pipe (F), then remove it.

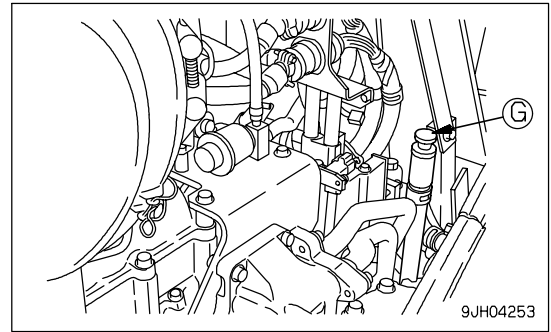

4. The oil on the oil level gauge (G) should be between the H mark and L mark.
If the oil is below the L mark, add oil through the dipstick guide.

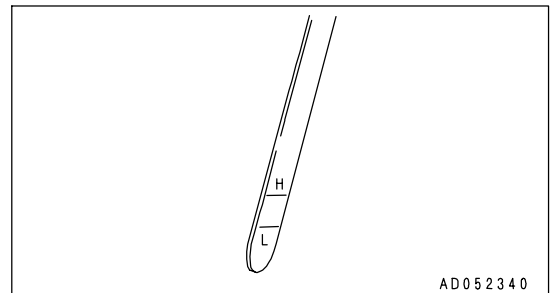

5. If the oil is above the H mark, open inspection cover (2) in the center of the bottom face of the power train case, drain the excess oil from drain plug (P) of the engine damper which can be seen towards the front of the machine from the inspection window, then check the oil level again.

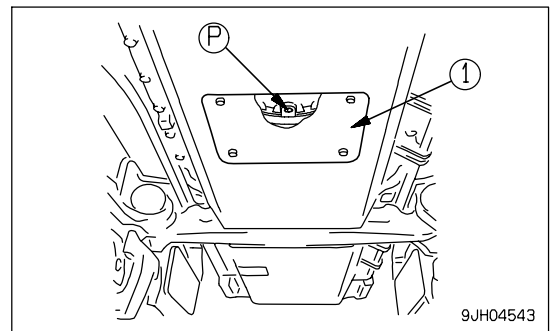

REMARK

- Check the oil level while the engine is stopped.
- If the machine is inclined, set it in a level position before checking the oil level.

EVERY 500 HOURS SERVICE

Maintenance for every 250 hours should be performed at the same time.

CHANGE OIL IN ENGINE OIL PAN, REPLACE ENGINE OIL FILTER CARTRIDGE

(including engine by-pass filter cartridge)



WARNING

Parts and oil are at high temperature immediately after the engine is stopped and may cause serious burns. Wait for the oil temperature to go down before performing this operation.

- Refill capacity: 38 liters (10.04 US gal)
 - Prepare a socket wrench and filter wrench.
1. Remove the covers at the bottom left at the front of the machine and on the side face, and put a container directly underneath to catch the drained oil.
 2. Loosen drain plug (P) (with a slit) slowly to avoid getting oil on yourself, and drain the oil.
 3. Check the drained oil, if there is excessive metal particles or foreign material, contact your Komatsu distributor.
 4. Install drain plug (P).
 5. Using a filter wrench, turn filter cartridge (1) counterclockwise to remove it.
 6. Clean the filter holder, fill the new filter cartridge with clean oil, coat the thread and packing portion of the new filter cartridge with oil (or coat thinly with grease), then install.
 7. When installing the filter cartridge, bring the packing surface into contact with the filter holder, then tighten a further 3/4 to 1 turn.
 8. After replacing the filter cartridge, add oil through oil filler (F) until the oil level is between the H and L marks on the dipstick (G).
 9. Run the engine at idling for a short time, then stop the engine, and check that the oil level is between the H and L marks on the dipstick. For details, see "CHECK OIL LEVEL IN ENGINE OIL PAN, ADD OIL (PAGE 3-78)".

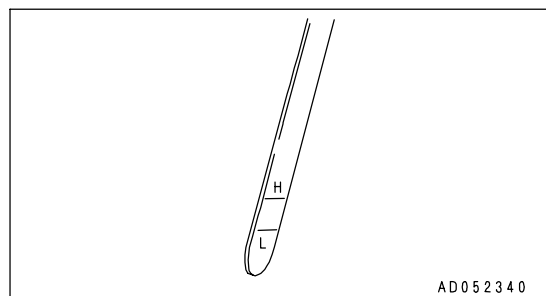
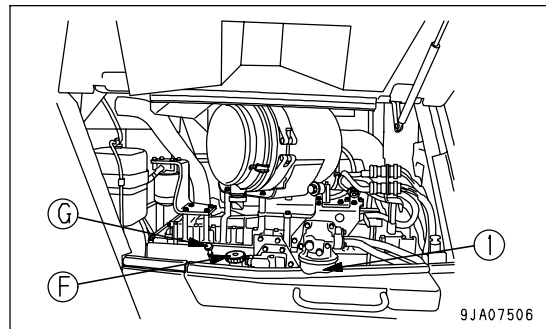
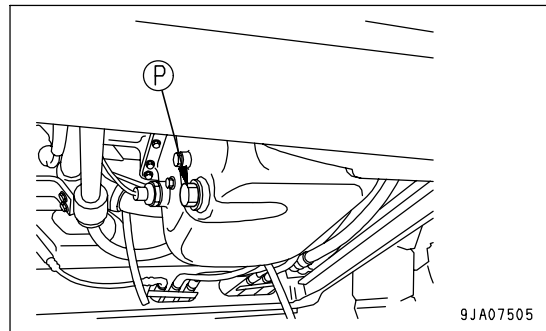

REPLACE PRE-FUEL FILTER CARTRIDGE

 **WARNING**

- After the engine has been operated, all parts are at high temperature, so do not replace the filter immediately. Wait for all parts to cool down before starting the operation.
- High pressure is generated inside the engine fuel piping system when the engine is running. When replacing the filter, wait for at least 30 seconds after stopping the engine to let the internal pressure go down before replacing the filter.
- Do not bring any fire or flame close.
- Be careful when opening the air bleed plug in the fuel filter head. It is still under pressure, so fuel may spurt out.

NOTICE

- Genuine Komatsu fuel filter cartridges use a special filter that has highly efficient filtering ability. When replacing the filter cartridge, always use a genuine Komatsu part.
- The common rail injection system used on this machine consists of more precise parts than the conventional injection pump and nozzle. If any part other than a genuine Komatsu filter cartridge is used, dust or dirt may get in and cause problems with the injection system. Always avoid using substitute parts.
- When carrying out inspection or maintenance of the fuel system, pay more attention than normal to the entry of dirt. If dirt is stuck to any part, use fuel to wash it off completely.

Prepare a filter wrench and a container to catch the fuel.

1. Close the fuel valve (1).

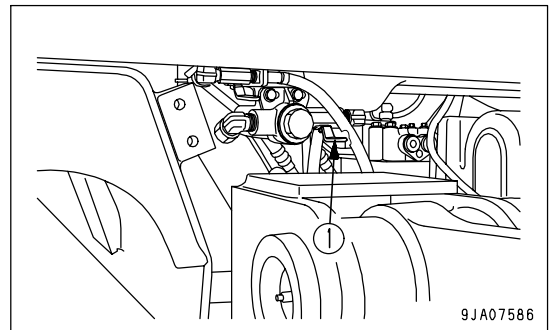

2. Set the container to catch the fuel under the pre-fuel filter cartridge.
3. Using a filter wrench, turn filter cartridge (2) counterclockwise to remove it.
4. After removing the cartridge, turn cup (3) of the water separator installed to the bottom of the cartridge counterclockwise. (This cup is used again. If it is damaged, replace it with a new part.)

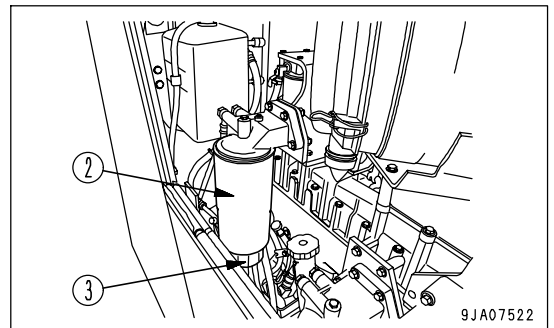

5. Install cup (3) to the bottom of the new pre-fuel filter cartridge. When doing this, always replace the seal ring with a new part.
 - Cup tightening torque: 10 Nm (1.0 kgm , 7.2 lbft)

When the seal ring has been replaced, coat the surface with clean fuel before installing it.

6. Check that the drain plug(4) at the bottom of the pre-fuel filter cup(3) is tightened securely.
Tightening torque: 0.2 to 0.45 Nm (0.02 to 0.046 kgm , 0.1 to 0.3 lbf)
7. Clean the filter holder.

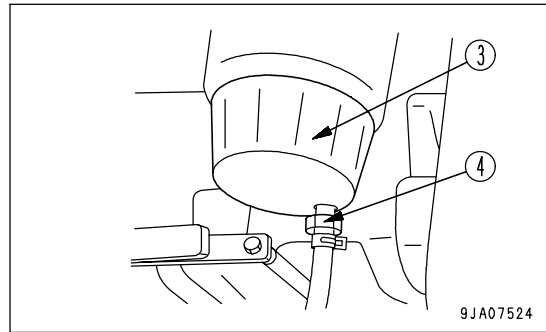

NOTICE

When filling the filter cartridge with fuel, carry out the filling operation with cap (A) fitted.
Cap (A) acts to prevent the entry of dirt or dust into the filter cartridge.

8. Fill the filter cartridge with clean fuel through the 8 small holes (B) in the new filter cartridge.
9. Coat the packing surface of the filter cartridge with oil.

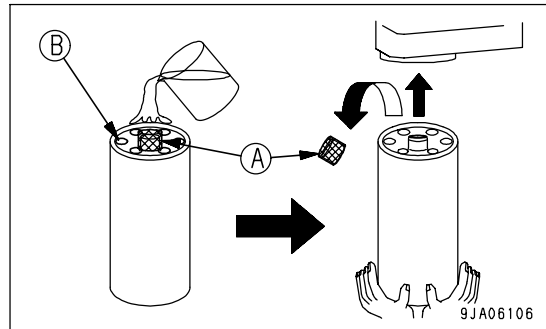

10. Remove filter cartridge cap (A) and install to the filter holder.

11. When installing, tighten until the packing surface contacts the seal surface of the filter holder, then tighten it 3/4 of a turn.
If the filter cartridge is tightened too far, the packing will be damaged and this will lead to leakage of fuel. If the filter cartridge is too loose, fuel will also leak from the packing, so always tighten the correct amount.
 - When tightening with a filter wrench, be extremely careful not to dent or damage the filter.

12. When carrying out standard replacement of the fuel filter cartridge (every 1000 hours), replace the cartridge and bleed the air. For details, see "REPLACE FUEL MAIN FILTER CARTRIDGE (PAGE 4-60)".

13. Open the fuel valve (1).

14. Start the engine, check that there is no leakage of fuel from the filter seal surface or water separator mounting surface, then run for approx. 10 minutes at low idling.

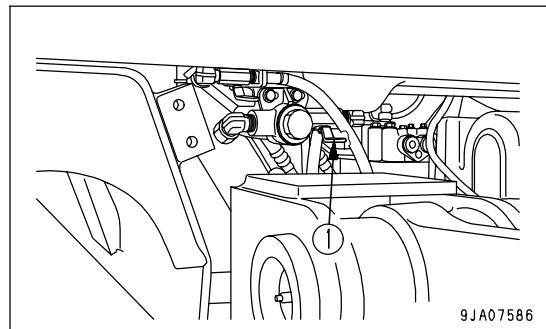

REPLACE POWER TRAIN OIL FILTER ELEMENT

! WARNING

- Immediately after the engine is stopped, the oil and parts are at high temperature, and may cause burns. To prevent this, wait for the temperature to go down before starting the operation.
- Before opening the filter cases, depress the brake pedal several times to release the pressure, then lock the brake pedal. If there is still pressure inside the filter, oil may spurt out.

1. Open the engine side cover on the left of the machine.

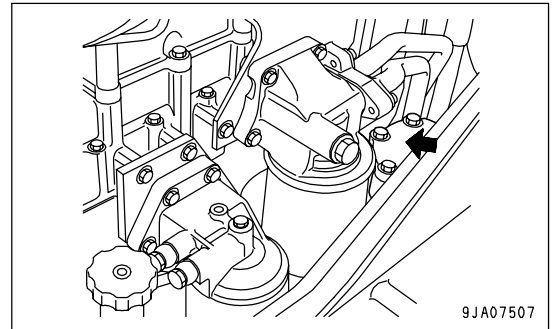

2. Remove bolts (1) and cover (2) is lifted up, then take out element (3).
3. Clean inside of the case and the removed parts, then install a new element.
- Replace the O-ring with a new one.

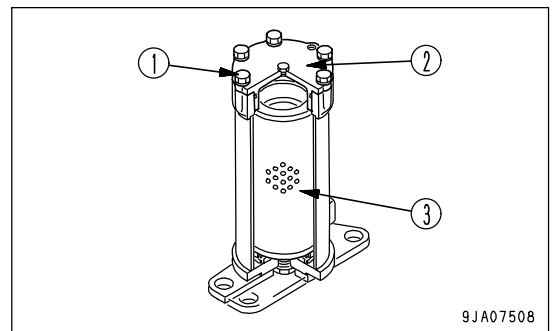

CHECK OIL LEVEL IN FINAL DRIVE CASE, ADD OIL

! WARNING

There is danger that oil may spurt out under internal pressure, so stand to the side, and gradually turn the plug to release internal pressure before removing the plug.

1. Place the machine on a horizontal place.
2. Remove oil level plug (G) and check whether the final drive case is filled with oil to lower edge of the plug hole.
3. If the oil level is low, add oil through oil level plug (G). Before removing the oil level plug (G), remove all the mud and dirt from around the plug, and be careful not to let any dirt or mud get in when adding oil.

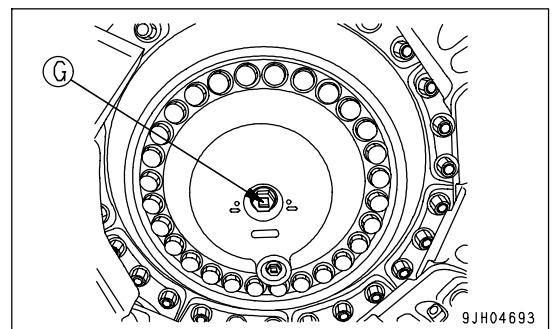

EVERY 1000 HOURS SERVICE

Maintenance for every 250 and 500 hours service should be carried out at the same time.

CHANGE OIL IN POWER TRAIN CASE, WASH STRAINERS (POWER TRAIN PUMP STRAINER, SCAVENGING PUMP STRAINER)**WARNING**

- The oil is at high temperature immediately after operations, so wait for the temperature to go down before starting the operation.
 - The undercover is heavy. Do not go directly under the cover when opening or closing it. When removing bolts (5), carry out the operation at the rear of the point immediately under the cover so that it is possible to escape at any time.
- Prepare the following.

- Refill capacity: 60 liters (15.85 US gal)

1. Remove drain cover (1) at the bottom Right of the power train case, then loosen drain plug (P) and drain the oil.
Do not remove drain plug (P).
2. After draining the oil, tighten drain plug (P).

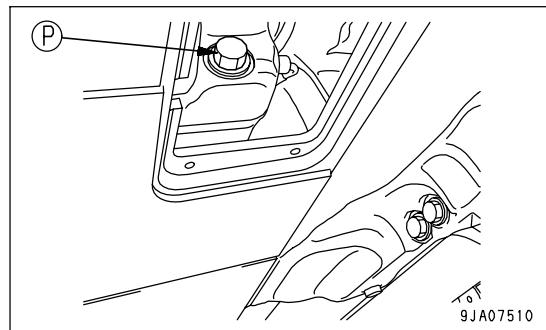
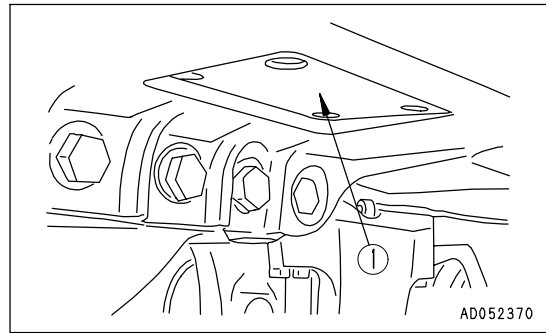

3. Remove inspection cover (2) in the undercover at the bottom rear of the machine as follows.
 - 1) Remove 2 bolts (3) at the Right of machine.
 - 2) Hold cover (2) in position and gradually remove 2 bolts (4) at the Left of machine. (Rain water may flow out when doing this.)

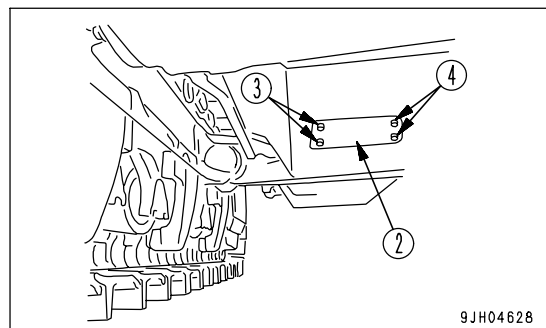

- 3) Lower cover (2) slowly and open it. (The right side of the cover has a hinge.)
The strainer can be seen at portion P at the top.

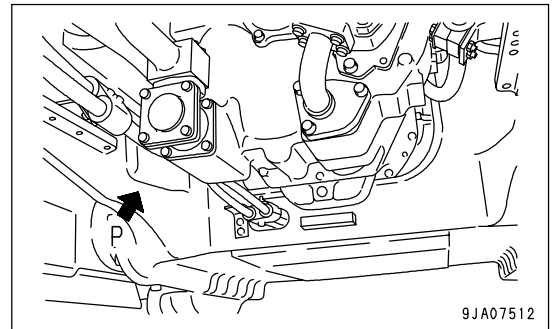
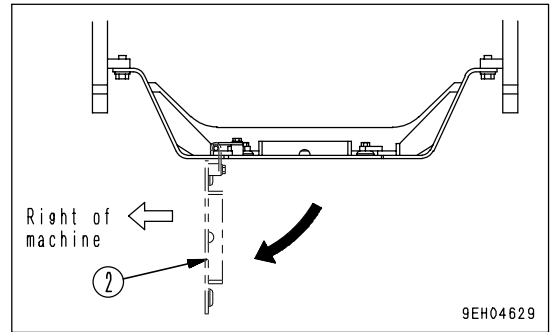

4. Remove drain plug (P2) in the strainer cover, and drain the oil (approx. 4 liters (1.06 US gal)) collected inside the piping.
5. Loosen mounting bolt (5) of the power train strainer, then remove cover (6).
6. Remove spring (7), then remove strainer (8).
7. Remove any dirt stuck to strainer (8), then wash it in clean diesel oil or flushing oil. Wash the removed parts and the inside of the case at the same time.
8. Loosen mounting bolt (9) of the scavenging pump strainer, then remove cover (10).
9. Remove strainer (11).

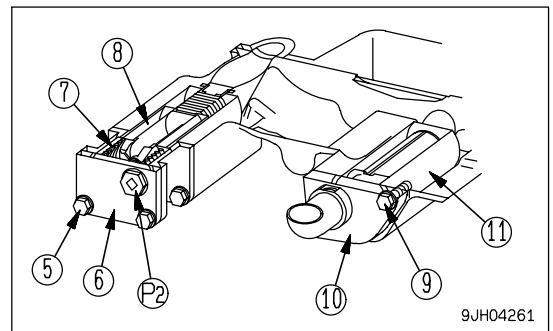

10. Remove any dirt stuck to strainer (11), then wash it in clean diesel oil or flushing oil. Wash the removed parts and the inside of the case at the same time.
11. Install the strainers in their original position.
12. Replace the power train filter element.

For details, see "REPLACE POWER TRAIN OIL FILTER ELEMENT (PAGE 4-55)".

13. Refill the specified quantity of oil through oil filler (F).
14. After filling with oil, check that the oil is at the specified level.
For details, see "CHECK OIL LEVEL IN POWER TRAIN CASE, ADD OIL (PAGE 3-82)".

If the spring or strainer are damaged, replace them with a new part.

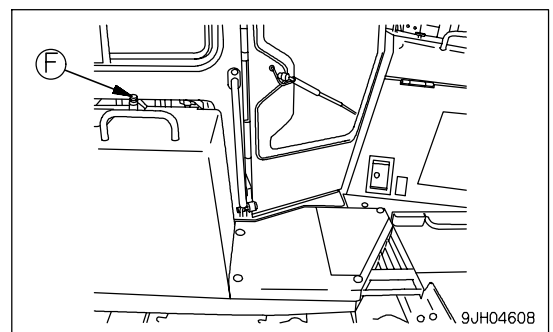

REPLACE HYDRAULIC TANK BREATHER ELEMENT

**WARNING**

- The parts and oil are at high temperature immediately after the engine is stopped, and may cause burns. Wait for the temperature to go down before starting the work.
- When removing the oil filler cap, oil may spurt out, so push the cap down to release the internal pressure, then remove the cap carefully.

1. Push down cap (1) of oil filler (F) to release the air and remove the internal pressure.
2. Keep cap (1) pushed down, turn it slowly counterclockwise, then remove cap (1).

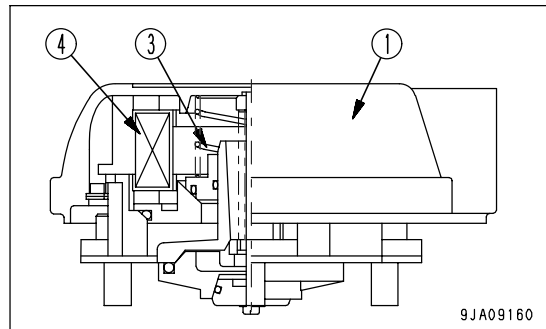
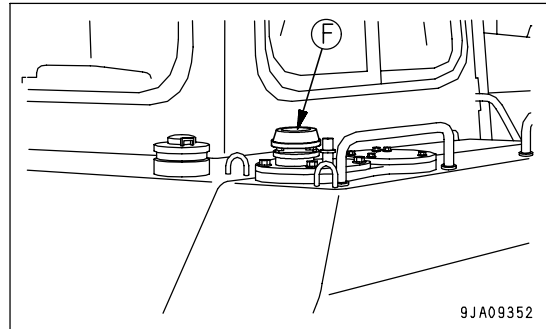

3. Remove ring (2) from inside the lip of cap (1).
4. Remove valve (3).
5. Replace filter element (4).

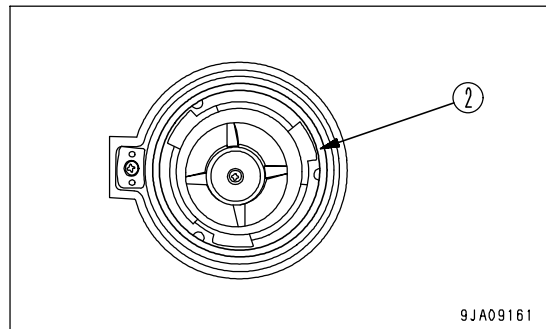

6. Install valve (3) and ring (2) in their original positions.
7. Install cap (1).
When installing cap (1) to the tank, push it down, then turn it clockwise.

REMARK

If the cap is not installed correctly, it will cause leakage of oil.

When installing the cap, press the cap down, and turn it until it is securely in contact with the stopper.

The cap is the lock addition type.

About handling method of cap with the lock, see "CAP WITH LOCK (PAGE 3-49)".

CHANGE OIL IN FINAL DRIVE CASE

⚠ WARNING

- The oil is at high temperature immediately after the machine has been operated. Wait for the oil to cool down before starting the operation.
- There is danger that oil spouts out due to the internal pressure. When removing the plug, work from the side, turn the plug slowly to release the internal pressure, and remove it carefully.

- Refill capacity:
 D85EX : (each) 26 liters (6.87US gal)
 D85PX : (each) 36 liters (9.51US gal)
- 1. Stop the machine so that drain plug (H) is directly at the bottom.
- 2. After removing oil filler/level plug (G), remove drain plugs (H) and (I), drain the oil, then tighten the plug again.
- 3. Add the replacement amount of oil through the hole of plug (G).
- 4. After adding oil, check that the oil is up to to the specified level.
 For details, see "CHECK OIL LEVEL IN FINAL DRIVE CASE, ADD OIL (PAGE 4-55)".

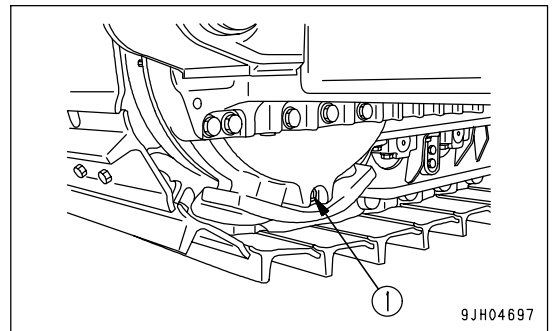
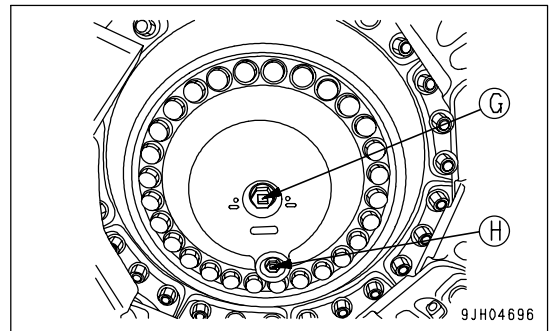

CHECK, CLEAN FUEL STRAINER

1. Close fuel supply valve (1), then remove strainer cap (2).
 The strainer forms one unit with the strainer cap.
2. Remove any dirt stuck to the strainer, then wash in clean diesel fuel or flushing oil. If the strainer is damaged, replace it.
3. After checking and cleaning, set the strainer in the case, then tighten cap (2).
4. After installing, open fuel supply valve (1).

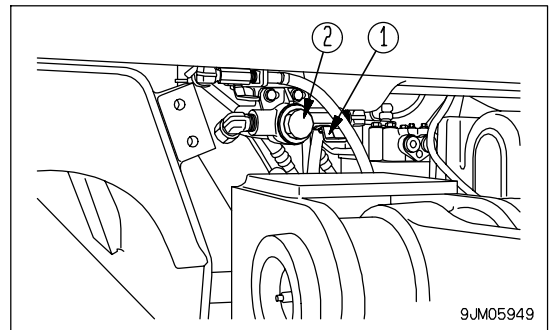

REPLACE FUEL MAIN FILTER CARTRIDGE

Carry out this operation after carrying out the maintenance in the "REPLACE PRE-FUEL FILTER CARTRIDGE (PAGE 4-53)" for every 500 hours.

**WARNING**

- After the engine has been operated, all parts are at high temperature, so do not replace the filter immediately. Wait for all parts to cool down before starting the operation.
- High pressure is generated inside the engine fuel piping system when the engine is running. When replacing the filter, wait for at least 30 seconds after stopping the engine to let the internal pressure go down before replacing the filter.
- Do not bring any fire or flame close.
- Be careful when opening the air bleed plug in the fuel filter head. It is still under pressure, so fuel may spurt out.

NOTICE

- Genuine Komatsu fuel filter cartridges use a special filter that has highly efficient filtering ability. When replacing the filter cartridge, always use a genuine Komatsu part.
- The common rail fuel injection system used on this machine consists of more precise parts than the conventional injection pump and nozzle. If any part other than a genuine Komatsu filter cartridge is used, dust or dirt may get in and cause problems with the injection system. Always avoid using substitute parts.
- When carrying out inspection or maintenance of the fuel system, pay more attention than normal to the entry of dirt. If dirt is stuck to any part, use fuel to wash it off completely.

Prepare a filter wrench and a container to catch the fuel.

1. Set the container under the filter cartridge to catch the drained oil.
2. Close the fuel valve (1).

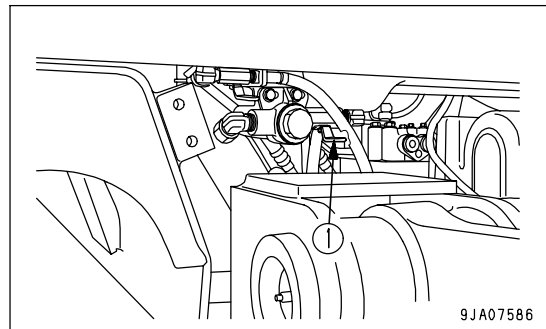

3. Using a filter wrench, turn filter cartridge (2) counterclockwise to remove it.

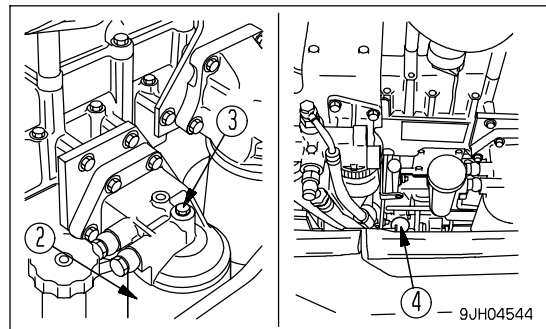

NOTICE

- Do not fill the fuel filter cartridge with fuel.
- Remove cap (B) and install the fuel filter.

4. Clean the filter holder, coat the packing surface of the new filter cartridge thinly with oil, then install the filter cartridge to the filter holder.

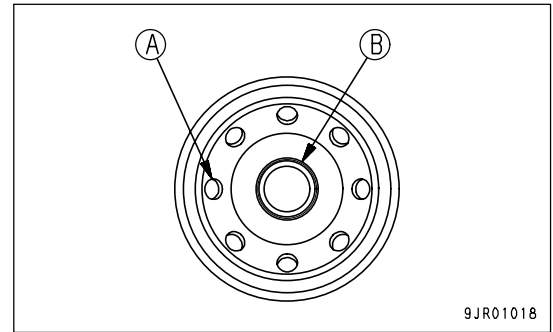

5. When installing, tighten until the packing surface contacts the seal surface of the filter holder, then tighten it 3/4 of a turn.

If the filter cartridge is tightened too far, the packing will be damaged and this will lead to leakage of fuel. If the filter cartridge is too loose, fuel will also leak from the packing, so always tighten the correct amount.

Bleed the air as follows:

6. Open the cock(1) and loosen air bleeding plug (3).
7. Loosen the knob of priming pump (4), move it up and down, and continue until no more bubbles come out with the fuel from air bleed plug (3).
8. Tighten air bleed plug (3), push in the knob of priming pump (4), then tighten it.
9. After replacing the filter cartridge, start the engine and check for leakage from the filter seal surface.

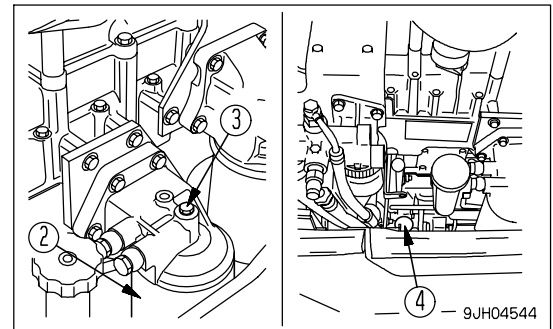

REMARK

When only the filter cartridge is replaced, it is sufficient that air bleeding is carried out for the filter head alone. But when the fuel piping is removed, air bleeding should also be carried out for the injection pump air-bleeding valve.

CHECK TIGHTENING PARTS OF TURBOCHARGER

Contact your Komatsu distributor to have the tightening portions checked.

REPLACE CORROSION RESISTOR CARTRIDGE

**WARNING**

If the engine has been operated, all parts will be at a high temperature, so never try to replace the cartridge immediately after stopping the engine.

Always wait for the engine and other parts to cool down.

- Container to catch drained coolant
 - Prepare a filter wrench for fuel filter element.
1. Turn valve (2) of corrosion resistor (1) as far as the CLOSE stopper.
 2. Set a container to catch the coolant under the cartridge.
 3. Using a filter wrench, turn cartridge (3) to the left to remove it.
 4. Clean the filter holder, coat the packing surface and thread of the new cartridge with oil, then install it to the filter holder.
 5. When installing, tighten until the packing surface contacts the seal surface of the filter holder, then tighten it up 2/3 of a turn. If the filter cartridge is tightened too far, the packing will be damaged and this will lead to leakage of coolant. If the filter cartridge is too loose, coolant will also leak from the packing, so always tighten to the correct amount.
 6. Turn valve (2) of the cartridge to the OPEN position.
 7. After replacing the cartridge, start the engine and check for any coolant leakage from the filter seal surface. If there is any leakage, check if the cartridge is tightened properly.

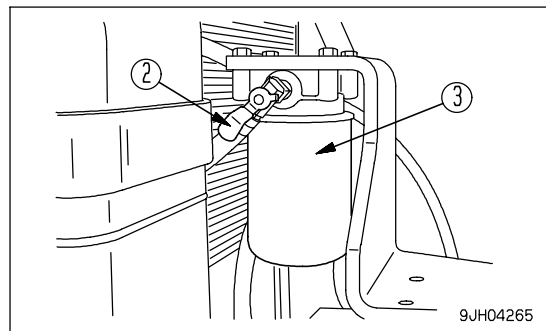
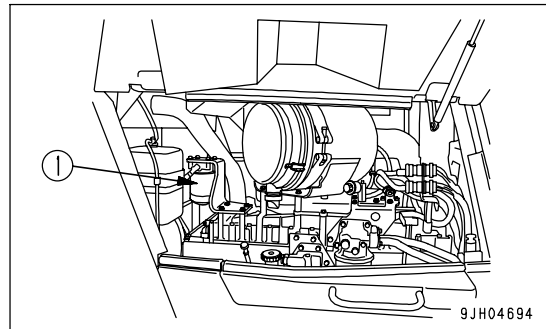

EVERY 2000 HOURS SERVICE

Maintenance for every 250, 500 and 1000 hours service should be carried out at the same time.

CHANGE OIL IN HYDRAULIC TANK, REPLACE HYDRAULIC OIL FILTER ELEMENT, CLEAN HYDRAULIC TANK STRAINER



WARNING

- The parts and oil are at high temperature immediately after the engine is stopped, and may cause burns. Wait for the temperature to go down before starting the work.
- When removing the oil filler cap, oil may spurt out, so push the cap down to release the internal pressure, then remove the cap carefully.

- Refill capacity: 71 liters (18.76 US gal)
1. Lower the work equipment to the ground, then stop the engine.
 2. Push down cap of oil filler (F) to release the air and remove the internal pressure.
 3. Keep cap pushed down, turn it slowly counterclockwise, then remove cap.

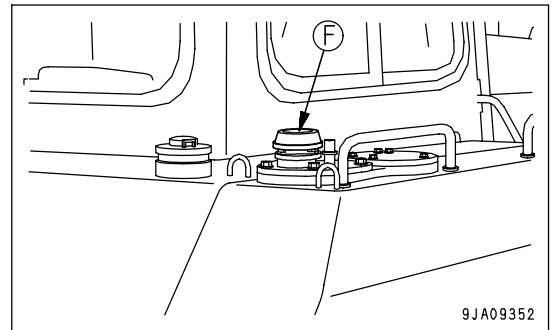

4. Remove drain plug (1) at the bottom of the tank and loosen drain valve (2). After draining the oil, tighten drain plug (1) and drain valve (2). When loosening drain valve (1), be careful not to get oil on yourself.

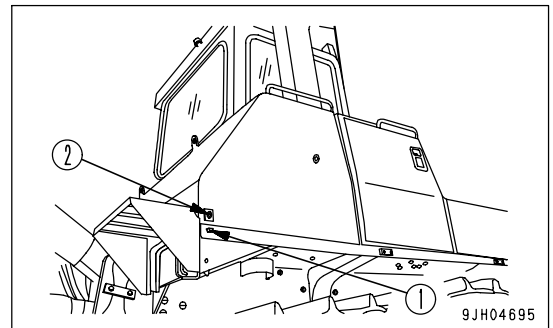

5. Remove bolts (3), then remove cover (4) and take out the element.
6. Clean the inside of case and removed parts and install a new element.

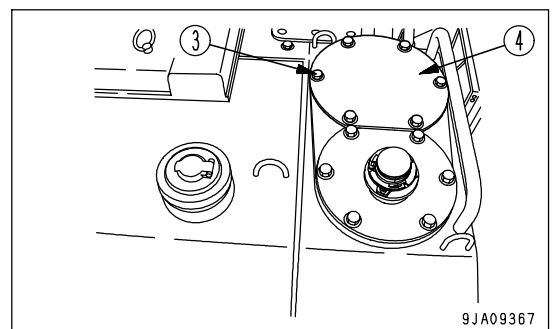

7. Remove bolts (5), then remove cover (6) and take out the strainer.
8. Wash the strainer in clean diesel oil or flushing oil.
9. Install the strainer to its original position.

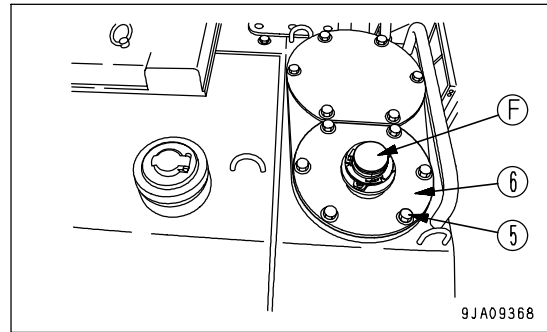

10. Add the refill amount of engine oil through oil filler port (F), then install the cap. When installing cap to the tank, push it down, then turn it clockwise.

REMARK

If the cap is not installed correctly, it will cause leakage of oil.

When installing the cap, press the cap down, and turn it until it is securely in contact with the stopper.

11. After adding oil, check that the oil is at the specified level. For details, see "CHECK OIL LEVEL IN HYDRAULIC TANK, ADD OIL (PAGE 3-83)".

CHANGE OIL IN DAMPER CASE, CLEAN DAMPER BREATHER**WARNING**

- The oil is at high temperature immediately after the machine has been operated. Wait for the oil to cool down before carrying out maintenance.
- The undercover is heavy, so do not go directly under the cover when opening or closing it. When removing bolts (2) and (3), carry out the operation at the rear of the point immediately under the cover so that it is possible to escape at any time.

- Refill capacity: 1.5 liters (0.40 US gal)
1. Open the engine side cover on the left of the machine; you can see dipstick (G).

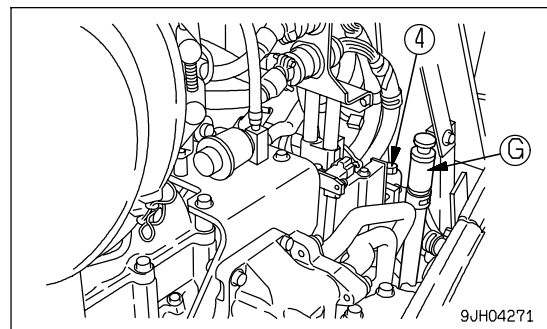

2. Remove the undercover (1) at the bottom rear of the chassis as follows.

- 1) Remove 2 bolts (2) at the Right of machine.
- 2) Hold cover (1) in position and gradually remove 2 bolts (3) at the Left of machine. (Rain water may flow out when doing this.)
- 3) Lower cover (1) slowly to open it. (There is a hinge on the right side of the cover.)
Drain plug (P) can be seen at the top.

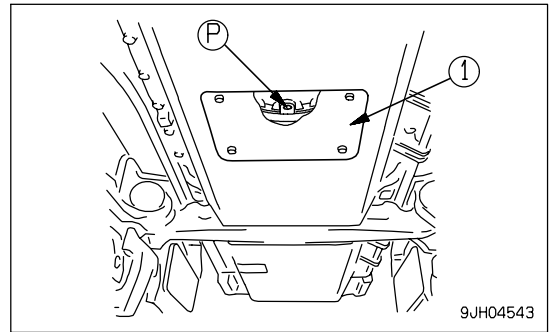

3. Remove dipstick (G), then remove drain plug (P) and drain the oil.

After draining the oil, tighten drain plug (P).

4. Add oil through the holder of dipstick (G). After adding the oil, insert dipstick (G).
5. Wipe away dust around the breather (4).
6. Remove breather (4).
7. Remove any dirt or dust stuck to breather (4), then wash with clean diesel oil or flushing oil. If it cannot be cleaned completely, replace with a new part.
8. Install the breather (4).
9. Then close cover (1).

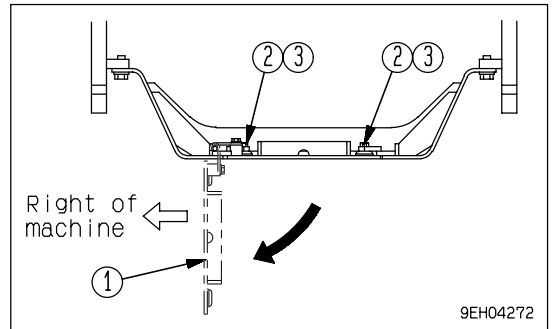

CHECK PIVOT BEARING OIL LEVEL, ADD OIL

1. Remove plug (1).

When removing plug (1), be careful not to let dirt or dust get it.

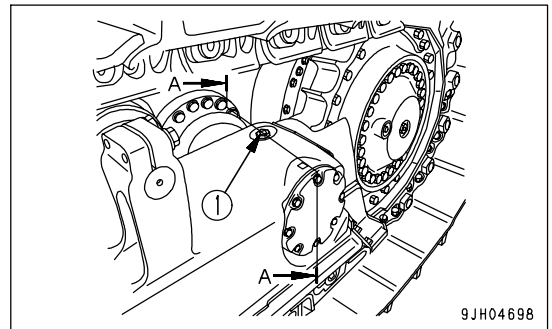

2. Check that the oil is at the level shown in the diagram. If the oil level is low, add oil through the hole of plug (1).

Use class TO30 (SAE 30) engine oil regardless of the ambient temperature.

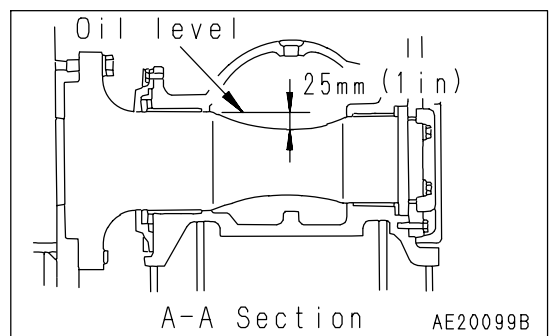

CHECKING CHARGE PRESSURE OF NITROGEN GAS IN ACCUMULATOR (FOR CONTROL CIRCUIT)

**WARNING**

The accumulator is charged with high-pressure nitrogen gas, so mistaken operation may cause an explosion, which will lead to serious injury or damage. When handling the accumulator, always do as follows.

- The pressure in the hydraulic circuit cannot be completely removed. When removing the hydraulic equipment, do not stand in the direction that the oil spurts out when carrying out the operation. In addition, loosen the bolts slowly when carrying out the operation.
- Do not disassemble the accumulator.
- Do not bring it near flame or dispose of it in fire.
- Do not make holes in it or weld it.
- Do not hit it, roll it, or subject it to any impact.
- When disposing of the accumulator, the gas must be released. Please contact your Komatsu distributor to have this work carried out.

FUNCTION OF ACCUMULATOR

The accumulator stores the pressure in the control circuit. Even after the engine is stopped, the control circuit can be operated, so the following actions are possible.

- If the control lever is operated in the direction to lower the work equipment, it is possible for the work equipment to go down under its own weight.
- The pressure in the hydraulic circuit can be released.

The accumulator is installed to the position shown in the diagram on the right.

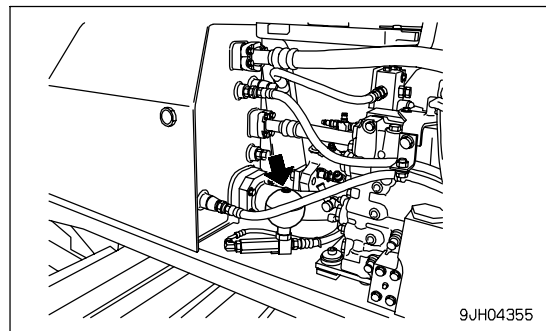
**CHECKING FUNCTION OF ACCUMULATOR**

Replace the accumulator every 2 years or every 4000 hours, whichever comes sooner.

Check the nitrogen gas charge pressure as follows.

1. Stop the machine on firm, level ground.
2. Set the parking brake lever to the LOCK position.

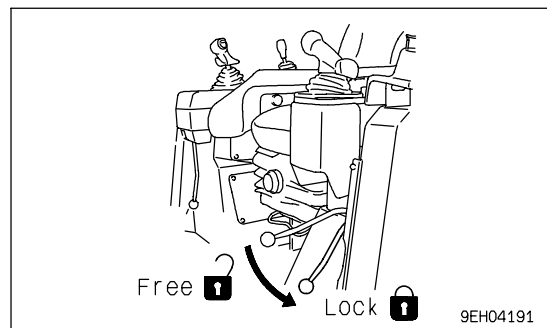

3. Raise the work equipment (blade) to the maximum height.

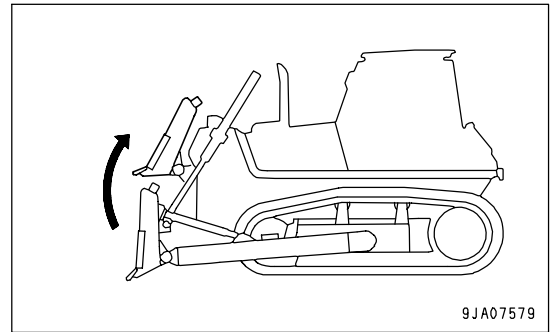

NOTICE

Carry out the following procedure for lowering the blade to the ground within 15 seconds after stopping the engine. When the engine is stopped, the pressure inside the accumulator gradually goes down, so this inspection can be carried out only immediately after the engine is stopped.

4. Leave the work equipment raised to the maximum height, turn the starting switch to the OFF position and stop the engine.
5. Turn the starting switch to the ON position.

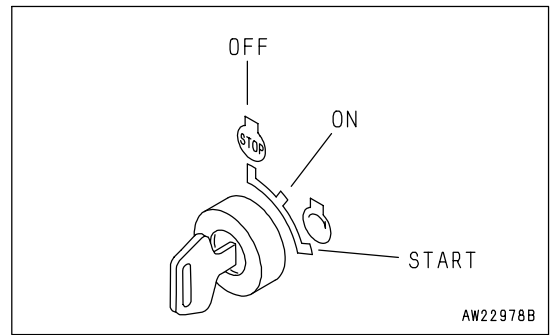

6. Set the work equipment lock lever to the FREE position.
7. Operate the blade control lever fully in the direction to lower the blade.

REMARK

Check that the area around the machine is safe, then operate the blade control lever to the LOWER position.

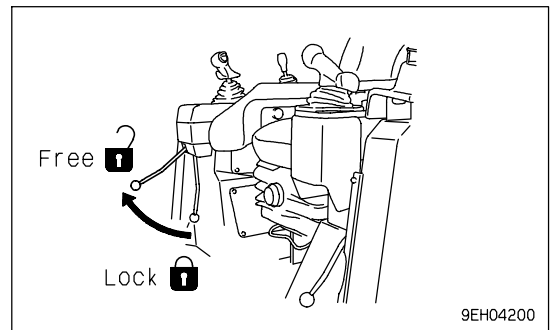

8. Check that the work equipment goes down to the ground under its own weight.
9. This completes the inspection.

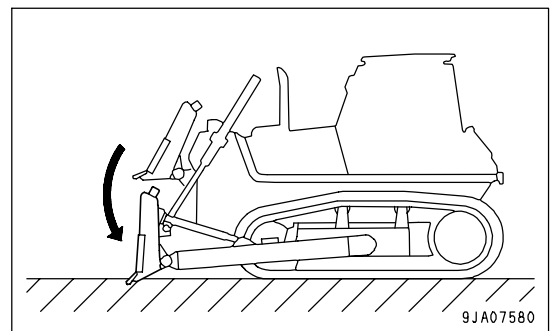

NOTICE

If the nitrogen gas charge pressure in the accumulator is low and operations are continued, it will become impossible to release the remaining pressure inside the hydraulic circuit if a failure occurs on the machine.

In the following cases, the charge pressure of the accumulator has gone down. Please contact your Komatsu distributor.

- Work equipment does not go down
- Stops while going down

METHOD OF RELEASING PRESSURE IN HYDRAULIC CIRCUIT

NOTICE

Finish the steps of operating the blade control lever to the front and back, and to the right and left, to each stroke end within 15 seconds after the engine has stopped. After the engine stops, pressure inside the accumulator begins to gradually go down, so the pressure cannot be released except right after the engine stops.

1. Lower the work equipment and stop the engine.
2. Turn the starting switch to the ON position.
3. Set the work equipment lock lever to the FREE position.
4. Operate the blade control lever fully to the front, rear, left, and right to release the pressure from the hydraulic circuit.

When releasing the pressure from the hydraulic ripper circuit, operate the ripper control lever fully to the left and right (in the case of the fixed multi-shank ripper) or to the front, rear, left, and right (in the case of the variable multi-shank ripper).

5. Set the work equipment lock lever to the LOCK position.

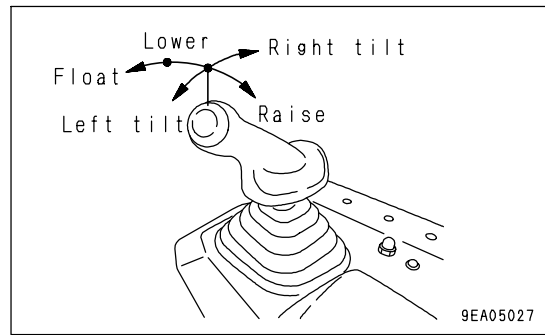

CLEAN ENGINE BREATHER ELEMENT**WARNING**

- The parts and oil are at high temperature after the engine is stopped, and may cause serious burns. Wait for the temperature to go down before cleaning the engine breather.
- When using compressed air, there is a hazard that dirt may be blown up and cause serious injury. Always use safety glasses, dust mask, or other protective equipment.

1. Wipe away dust around the breather.
2. Loosen clamp (1), then remove the hose.
3. Then remove breather (2).
4. Rinse the whole breather in diesel oil or flushing oil. Dry with compressed air, then install it.
5. Check the breather hose, and if any deteriorated oil is stuck to the inside, replace the hose with a new hose.

REMARK

The engine breather element is at the front end on top of the engine (behind the radiator).

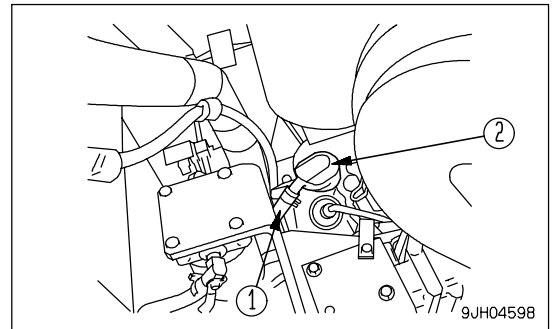
**CHECK ALTERNATOR, STARTING MOTOR**

The brushes may be worn or the bearing may have run out of grease, contact your Komatsu distributor for inspection and repairs.

If the engine is started frequently, have this inspection carried out every 1000 hours.

CHECK VIBRATION DAMPER

Check decrease of damper fluid, dent or out-of-flat. If there is any abnormality, contact Komatsu distributor for repair.

CLEAN AND CHECK TURBOCHARGER

Contact your Komatsu distributor for cleaning or inspection.

CHECK PLAY OF TURBOCHARGER ROTOR

Contact your Komatsu distributor to have the rotor play checked.

CHECK ENGINE VALVE CLEARANCE, ADJUST

Special tools are needed for inspection and maintenance, so contact your Komatsu distributor.

CHECK INJECTOR

See Section "A REGULATION AREA (PAGE 4-18)".

EVERY 4000 HOURS SERVICE

Maintenance for every 250, 500, 1000 and 2000 hours service should be carried out at the same time.

REPLACE ACCUMULATOR (FOR CONTROL CIRCUIT)



WARNING

The accumulator is charged with high-pressure nitrogen gas, so mistaken operation may cause an explosion, which will lead to serious injury or damage. When handling the accumulator, always do as follows.

- The pressure in the hydraulic circuit cannot be completely removed. When removing the hydraulic equipment, do not stand in the direction that the oil spurts out when carrying out the operation. In addition, loosen the bolts slowly when carrying out the operation.
- Do not disassemble the accumulator.
- Do not bring it near flame or dispose of it in fire.
- Do not make holes in it or weld it.
- Do not hit it, roll it, or subject it to any impact.
- When disposing of the accumulator, the gas must be released. Please contact your Komatsu distributor to have this work carried out.

If operations are continued after the performance of the accumulator has dropped, it will be impossible to release the remaining pressure in the hydraulic circuit if there should be a failure on the machine. Please ask your Komatsu distributor to replace the accumulator.

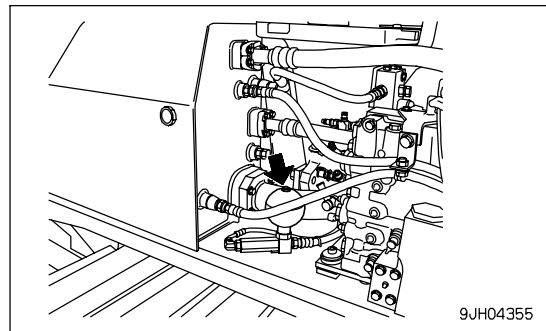

CHECK WATER PUMP

Check for oil and coolant leakage, or clogging of the drain hole. If any abnormality is found, contact your Komatsu distributor for disassembly, repair, or replacement.

CHECK INJECTOR

See Section "B REGULATION AREA (PAGE 4-18)".

REPLACE INJECTOR ASSEMBLY

See Section "A REGULATION AREA (PAGE 4-18)".

CHECKING FOR LOOSENESS OF HIGH-PRESSURE CLAMP, HARDENING OF RUBBER

Check visually and touch with your fingers to check that there are no loose bolts or hardening of rubber parts at clamps (1) to (10). If there is any looseness or hardened rubber, contact your Komatsu distributor for replacement.

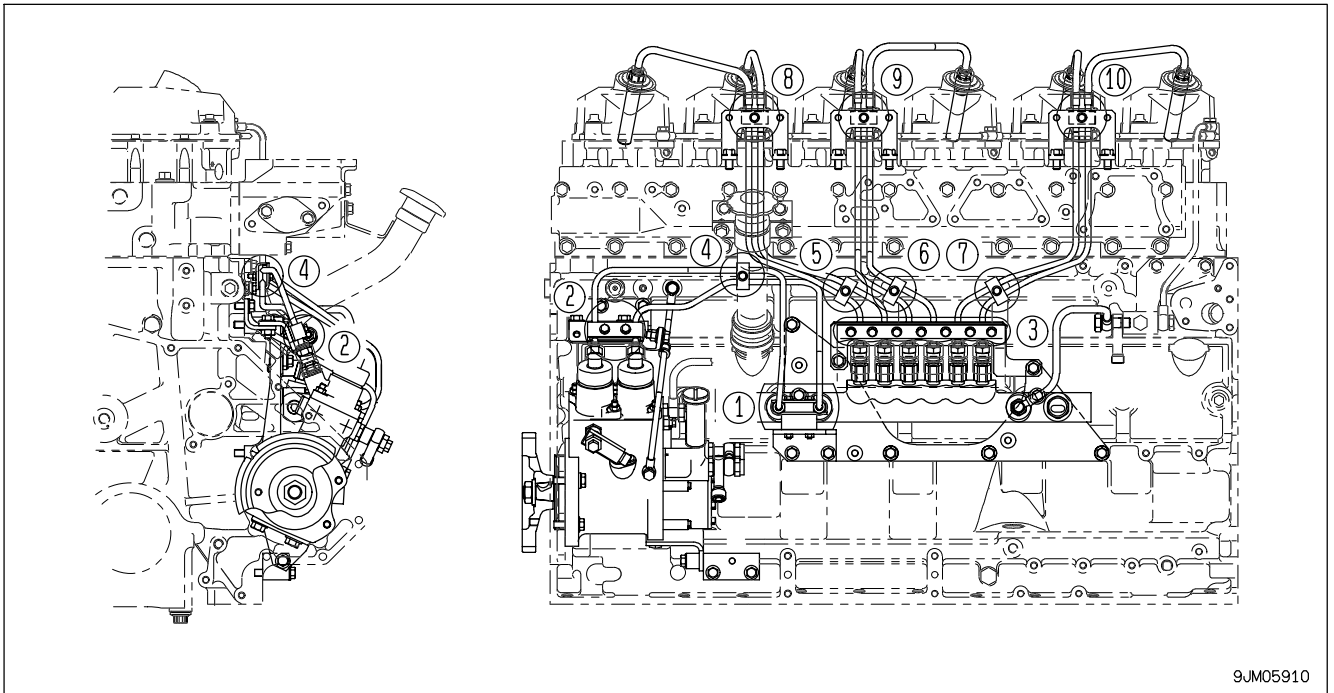

9JM05910

NOTICE

If the engine continues to be used when there are loose bolts, hardened rubber, or missing parts, there is danger of damage or breakage occurring due to vibration and wear at the connections of high-pressure piping. Always check that the proper high-pressure piping clamps are correctly installed.

CHECKING FOR MISSING FUEL SPRAY PREVENTION CAP, HARDENING OF RUBBER

Fuel spray prevention caps (1) - (16) and fuel spray prevention cover (17) are protective parts installed to prevent fire caused by fuel leaking and spraying out on to high temperature parts of the engine. Check visually that there are no missing caps or loose bolts, and feel with your finger to check that the rubber has not hardened. If there is any problem, the problem part must be replaced. Contact your Komatsu distributor for part replacement.

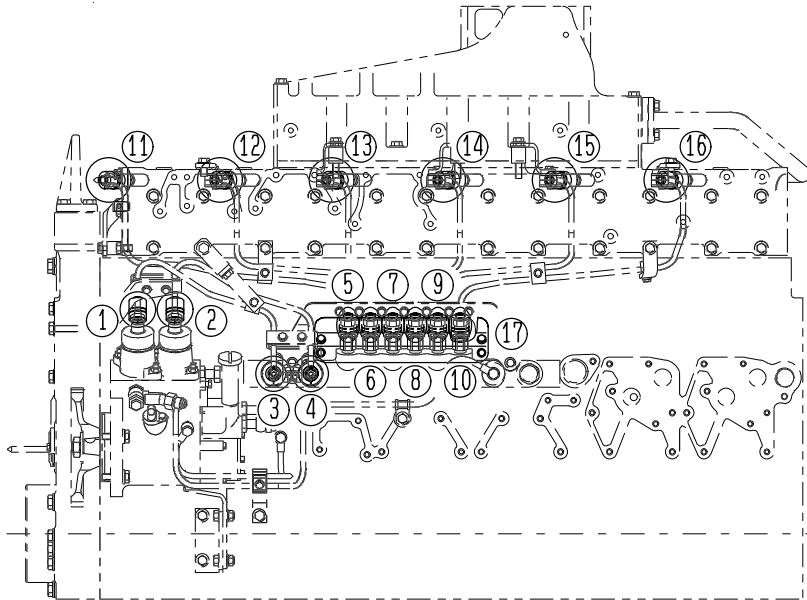

9JH01926

CHECK MAIN FRAME, WORK EQUIPMENT (BLADE, RIPPER)

Check after the first 4000 hours, and every 1000 hours after that.

- Preparation

Wipe off all the mud that is stuck around portions (A) - (L) of the work equipment and frame to make it easier to carry out the check.

- Visual check

Carefully check the base material of the steel casting and welding at portions (A) - (L), and check that there is no damage.

If any cracks or other damage is found, repair them.

Contact your Komatsu distributor for details of the repair procedure.

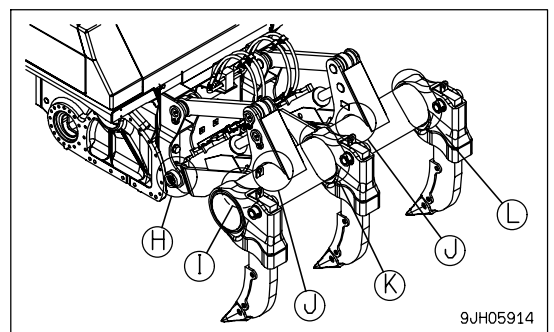
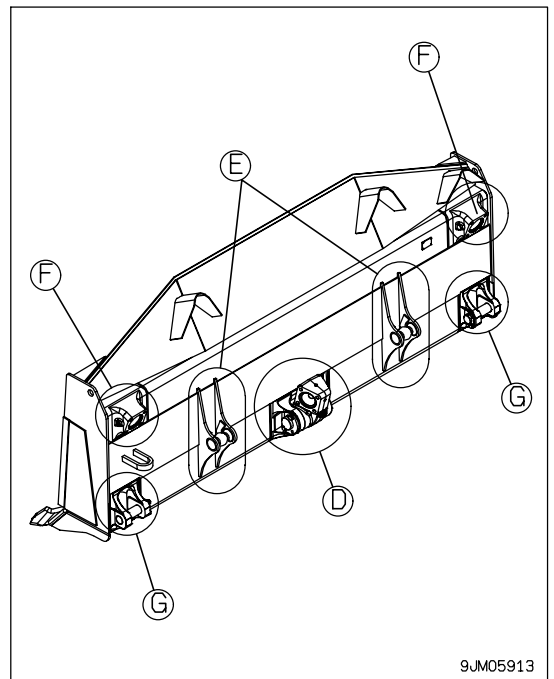
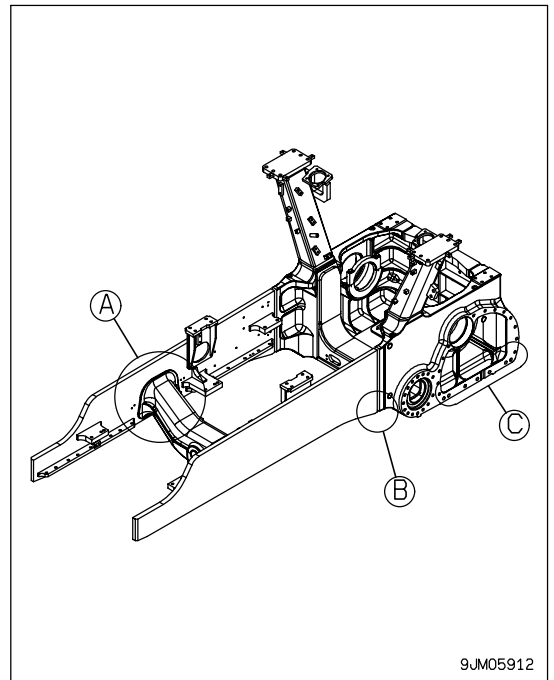

EVERY 8000 HOURS SERVICE

Maintenance for every 250, 500, 1000, 2000, and 4000 hours service should be carried out at the same time.

REPLACE INJECTOR NOZZLE TIP

See Section "B REGULATION AREA (PAGE 4-18)".

REPLACE HIGH-PRESSURE PIPING CLAMPS

Contact your Komatsu distributor to have the engine high-pressure clamps replaced.

REPLACE FUEL SPLAY PREVENTION CAPS

Contact your Komatsu distributor to have the fuel spray prevention cap replaced.

SPECIFICATIONS

SPECIFICATIONS

Item	Unit	D85EX-15	D85PX-15
		Semi-U tilt dozer	Straight tilt dozer
Operating weight (without operator)	kg (lb)	28,000 (61,740)(*1)	27,550 (60,748)(*2)
Blade unit weight (including cylinder)	kg (lb)	3,565 (7,861)	3,345 (7,376)
Ripper unit weight(Multi ripper)	kg (lb)	2,215 (4,884)	-
Drawbar unit weight	kg (lb)	-	176 (388)
Name of engine	-	KOMATSU SA6D125E-3 diesel engine	
Engine horsepower	kW(HP)/rpm	179 (240)/1,900	
A Overall length	mm (ft in)	7,255 (23'10")	6,065 (19'11")
B Overall height	mm (ft in)	3,330 (10'11")	3,360 (11')
C Overall width	mm (ft in)	3,635 (11'11")	4,365 (14'4")
Travel speed (1st/2nd/3rd)	Forward	km/h (MPH)	3.6/6.1/10.1 (2.2/3.8/6.3)
	Reverse	km/h (MPH)	4.7/8.0/13.0 (2.9/5.0/8.1)

*1: Semi-U tilt dozer, multi-shank ripper, ROPS cab, air conditioner

*2: Straight tilt dozer, drawbar, ROPS cab, and air conditioner

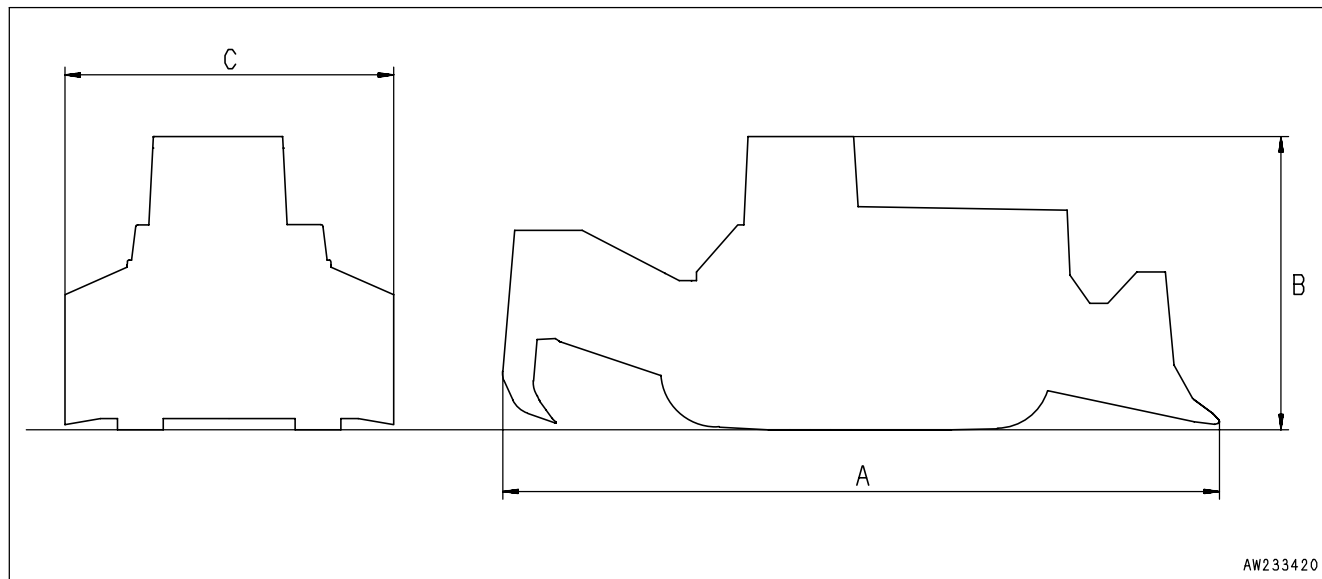

AW233420

ATTACHMENTS, OPTIONS

WARNING

Please read and make sure that you understand the SAFETY section before reading this section.

GENERAL PRECAUTIONS

PRECAUTIONS RELATED TO SAFETY

If attachments or options other than those authorized by Komatsu are installed, this will not only affect the life of the machine, but will also cause problems with safety.

When installing attachments not listed in this Operation and Maintenance Manual, contact your Komatsu distributor first.

If you do not contact Komatsu, we cannot accept any responsibility for any accidents or failures.



WARNING

General precautions

- Read the instruction manual for the attachment carefully, and do not use the machine before you understand the operation method completely.

If you lose the instruction manual, be sure to order another copy from your Komatsu distributor.

- To prevent serious personal injury caused by misoperation, place your foot on the pedal only when operating the pedal.

Precautions for removal and installation

When removing or installing an attachment, observe the following items and work safely.

- Select a firm, level surface when installing or removing an attachment.
- When working in cooperation with one or more other workers, decide signs and observe them when carrying out the operation.
- When carrying a heavy part (25 kg (55 lb) or more), use a crane.
- When removing a heavy part, always place a support in position before removing it.

When lifting a load with a crane, be particularly careful of the center of gravity.

- It is dangerous to carry out operations when the load has been raised by a crane. Always lower the load onto a stand and check that it is safe.
- When leaving an attachment removed or installing it, place it in a stable position to prevent it from falling over.
- Never go under a load raised by a crane.

Always stand in a place which is safe even if the load should fall.

NOTICE

Qualifications are required to operate a crane. Never allow the crane to be operated by an unqualified person.

For details of removal and installation operations, contact your Komatsu distributor.

SELECTION OF TRACK SHOE

Select suitable track shoes to match the operating conditions.

METHOD OF SELECTING SHOES

If a wider shoe than necessary is used, the load on the track will increase, and this will cause the shoes to bend, links to crack, pins to break, shoe bolts to come loose, and various other problems.

Category	Use	Precautions when using
A	Bedrock, normal soil	This shoe can be used for a wide range of work from crushed rock to general civil engineering work such as reclamation of residential land. There is no particular limit to its use.
B	Normal soil	Use this shoe for general soil, such as where the main work is scraper work and pusher work, reclaiming land for golf courses, or stripping the overburden for coal mines. This shoe cannot be used on bedrock. On jobsites where there are rocks in the soil, be careful to avoid letting the machine mount the rocks.
C	Soft soil	Use this shoe on soft ground where the shoe in category B sinks into the ground. Do not use this shoe on jobsites where there are rocks in the soil.
D	Extremely soft ground (swamp)	<ul style="list-style-type: none"> • With A, B, or C, use these shoes only in places where the machine sinks. • These shoes cannot be used on rough ground where there are large obstacles such as boulders or fallen trees. • Travel at Hi or Mi speed only on flat ground, and if it is impossible to avoid going over obstacles, shift down and travel at half speed in Lo.

REMARK

- Use heavy single shoes for machines operating in category A (rocky ground).
- Using heavy single shoes in categories B or C will help to improve the wear life.

	D85EX-15		D85PX-15	
	Specifications	Category	Specifications	Category
Standard	560mm Single	A	910mm Swamp	D
Option	610mm Single	B	---	---
Option	660mm Single	C	---	---
Option	560mm Heavy single	A	---	---
Option	610mm Heavy single	B	---	---
Option	660mm Heavy single	C	---	---

PROCEDURE FOR SELECTING RIPPER POINT

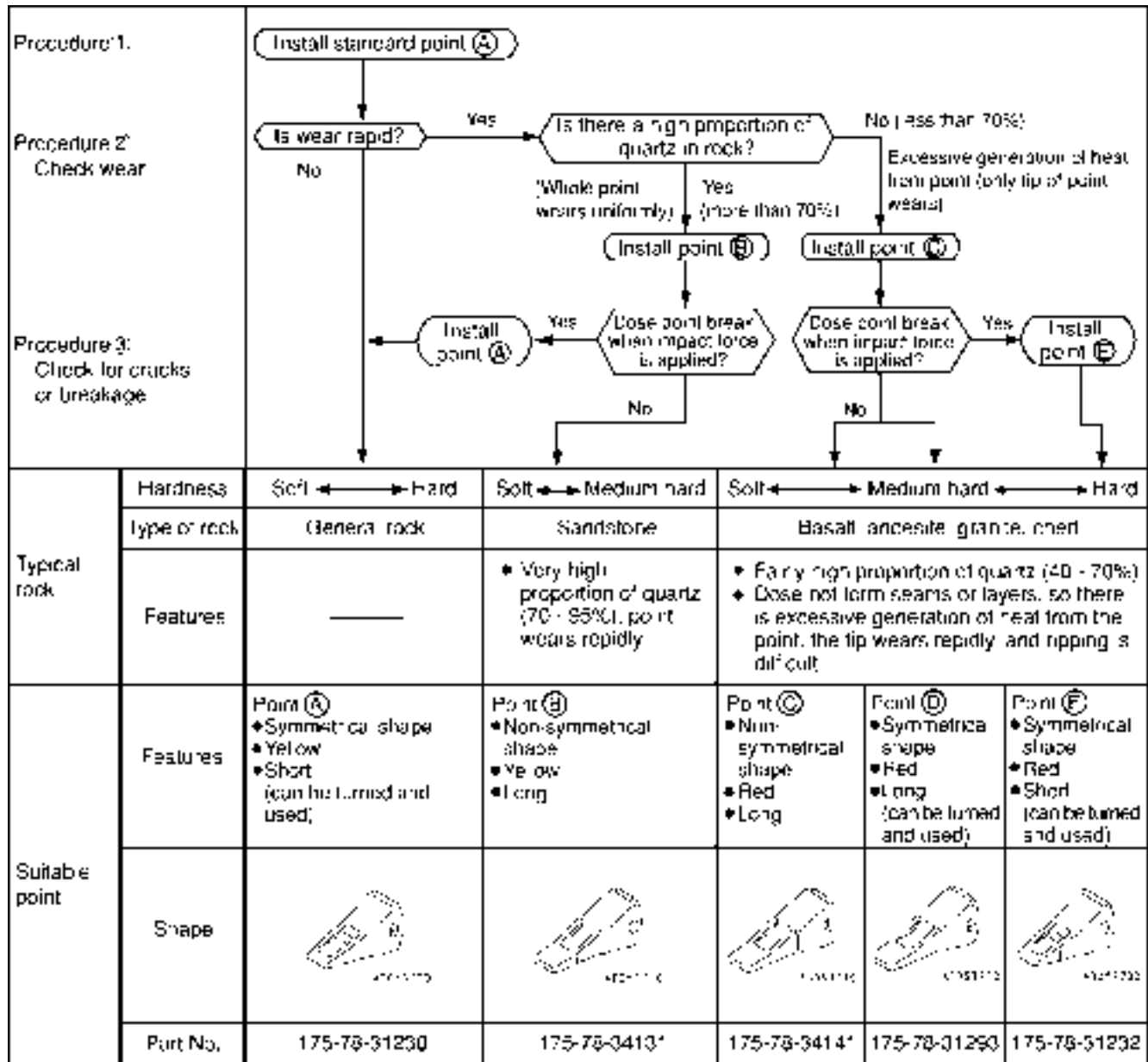

HANDLING TRIMMING DOZER

GENERAL VIEW

GENERAL VIEW OF MACHINE

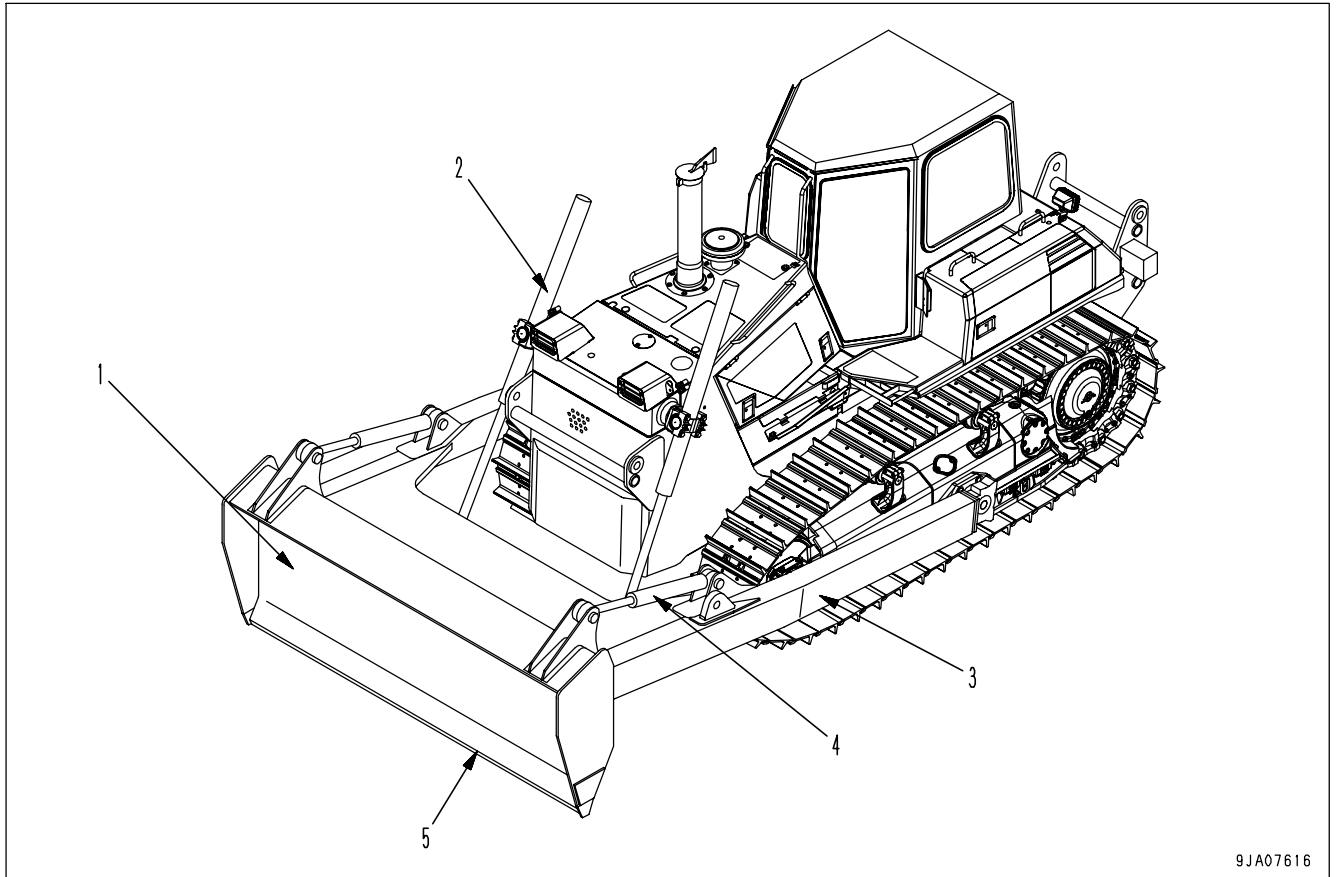

9JA07616

- | | |
|-------------------|-----------------------|
| (1) Blade | (4) Trimming cylinder |
| (2) Lift cylinder | (5) Cutting edge |
| (3) Frame | |

EXPLANATION OF COMPONENTS

The following is an explanation of devices needed for operating the machine.

To perform suitable operations correctly and safely, it is important to completely understand methods of operating the equipment, and the meanings of the displays.

CONTROL LEVERS AND PEDALS

WORK EQUIPMENT LOCK LEVER



WARNING

When standing up from the operator's seat, lower the blade to the ground and set the work equipment lock lever securely to the LOCK position. If the work equipment is not locked securely, there is danger of serious injury if the blade control lever is touched by mistake.

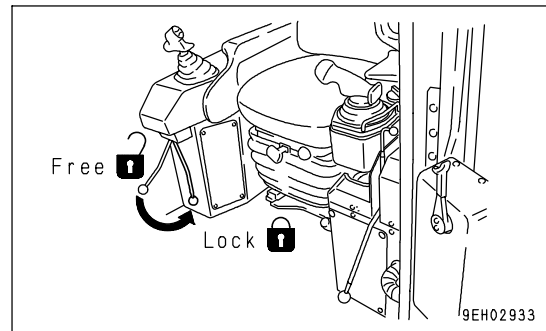

The work equipment lock lever is a device to lock the blade control lever. If it is set to the LOCK position, operations of the trimming dozer are locked.

REMARK

When starting the engine, to ensure safety, always set the work equipment lock lever to the LOCK position.

BLADE CONTROL LEVER

Use the blade control lever to operate the trimming dozer.

- (a) RAISE:
- (b) HOLD: Blade is stopped and held in this position.
- (c) LOWER:
- (d) FLOAT: Blade will move freely according to external force.
- (A) Tilted forward: Blade is tilted forward
- (B) Tilted back: Blade is tilted back

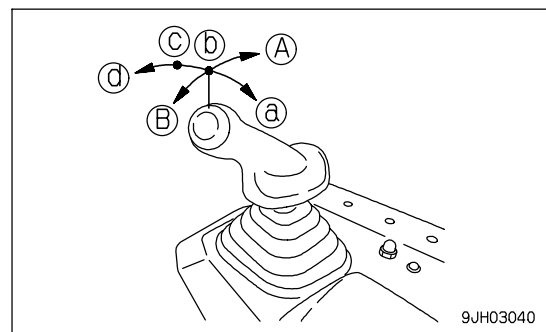

CAUTION

- Do not use this machine for dozing operations or digging operations.
- Do not operate the machine in forward or reverse with the machine jacked up by the blade.

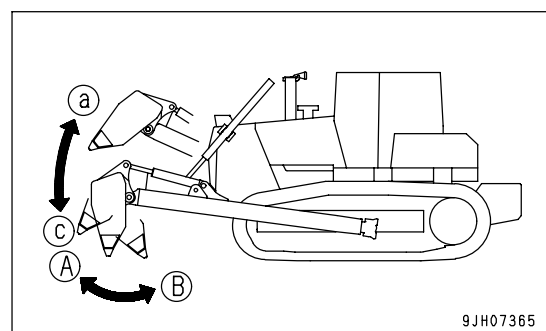

MAINTENANCE**MAINTENANCE SCHEDULE CHART****MAINTENANCE SCHEDULE CHART****EVERY 250 HOURS SERVICE**

LUBRICATING	6- 8
CHECK OIL LEVEL IN HYDRAULIC TANK, ADD OIL	6- 8

EVERY 2000 HOURS SERVICE

CHANGE OIL IN HYDRAULIC TANK, REPLACE HYDRAULIC OIL FILTER ELEMENT AND CLEAN HYDRAULIC TANK STRAINER	6- 9
---------------------------------------------------------------------------------------------------------------	------

SERVICE PROCEDURE

EVERY 250 HOURS SERVICE

LUBRICATING

1. Lower the work equipment to the ground, then stop the engine.
2. Using a grease pump, pump in grease through the grease fittings shown by arrows.
3. After greasing, wipe off any old grease that was pushed out.

- (1) Frame shaft (2 places)
- (2) Support shaft (2 places)
(hydraulic cylinder for trimming)
- (3) Piston rod (2 places)
(hydraulic cylinder for trimming)

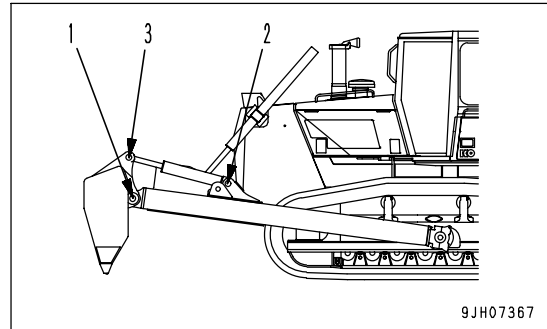

CHECK OIL LEVEL IN HYDRAULIC TANK, ADD OIL

Stop the machine at a level place, lower the blade perpendicularly to the ground, stop the engine, then carry out inspection.

REMARK

For details of the procedure for checking and adding oil, see "CHECKS BEFORE STARTING, CHECK OIL LEVEL IN HYDRAULIC TANK, ADD OIL" in the Operation and Maintenance Manual for the D85EX-15 bulldozer.

EVERY 2000 HOURS SERVICE

Carry out the maintenance for EVERY 250 HOURS SERVICE at the same time.

CHANGE OIL IN HYDRAULIC TANK, REPLACE HYDRAULIC OIL FILTER ELEMENT AND CLEAN HYDRAULIC TANK STRAINER**WARNING**

- The oil is at high temperature immediately after the machine has been operated. Wait for the oil to cool down before changing the oil.
- When removing the oil filler cap (F), push the cap down to release the internal pressure, then remove the cap carefully.

- Refill capacity: 71 liters (18.76 US gal)

1. Lower the blade to the ground, stop the engine, then move the blade to the front and rear.
2. Push down cap of oil filler (F) to release the air and remove the internal pressure.
3. Keep cap pushed down, turn it slowly counterclockwise, then remove cap.

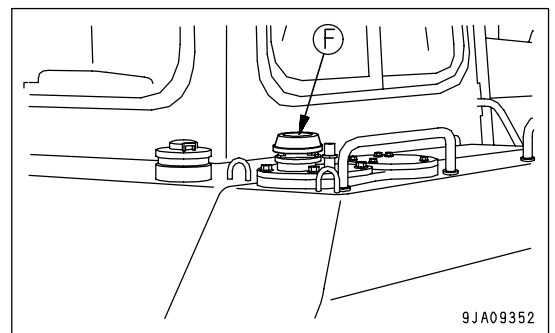

4. Remove drain plug (1) at the bottom of the tank and loosen drain valve (2). After draining the oil, tighten drain plug (1) and drain valve (2). When loosening drain valve (1), be careful not to get oil on yourself.

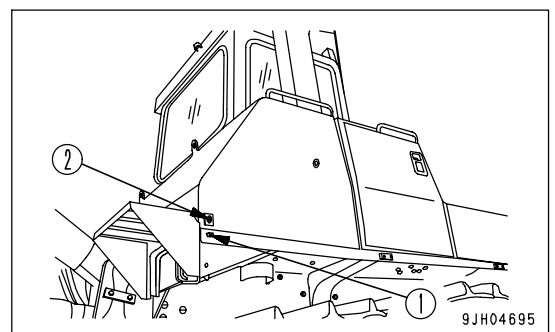

5. Remove bolts (3), then remove cover (4) and take out the element.
6. Clean the inside of case and removed parts and install a new element.

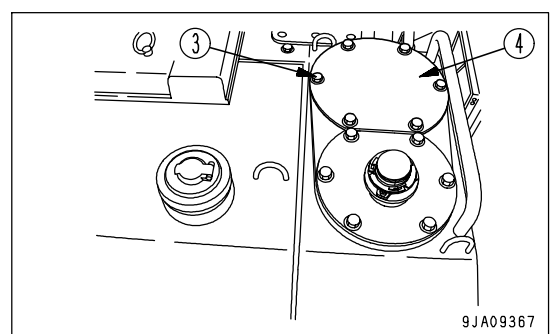

7. Remove bolts (5), then remove cover (6) and take out the strainer.
8. Wash the strainer in clean diesel oil or flushing oil.
9. Install the strainer to its original position.

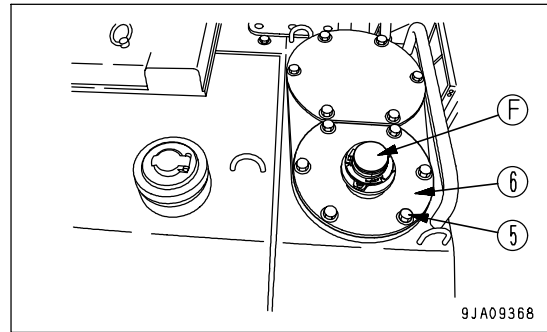

10. Add the refill amount of engine oil through oil filler port (F), then install the cap.
When installing cap to the tank, push it down, then turn it clockwise.

REMARK

If the cap is not installed correctly, it will cause leakage of oil.

When installing the cap, press the cap down, and turn it until it is securely in contact with the stopper.

11. After adding oil, check that the oil is at the specified level. For details, see "CHECKS BEFORE STARTING, CHECK OIL LEVEL IN HYDRAULIC TANK, ADD OIL" in the Operation and Maintenance Manual for the D85EX-15 bulldozer.

SPECIFICATIONS

	Item	Unit	D85EX-15 Trimming dozer
	Weight of bare machine (*1)	kg (lb)	3,810 (8,401)
	Operating weight (*2)	kg (lb)	25,760 (56,801)
	Hydraulic equipment Pump type Hydraulic oil Hydraulic oil amount	ℓ (US gal)	Force-feed plunger pump type Engine oil CD SAE10W 106 (28.01)
A	Overall length	mm (ft in)	6,690 (21' 11")
B	Overall height	mm (ft in)	3,045 (10' 0")
C	Overall width	mm (ft in)	3,410 (11' 2")
D	Blade forward tilt angle	degrees	35
E	Blade rear tilt angle	degrees	35

*1: Includes blade cylinder, trimming cylinder.

*2: Includes air conditioner, counterweight.

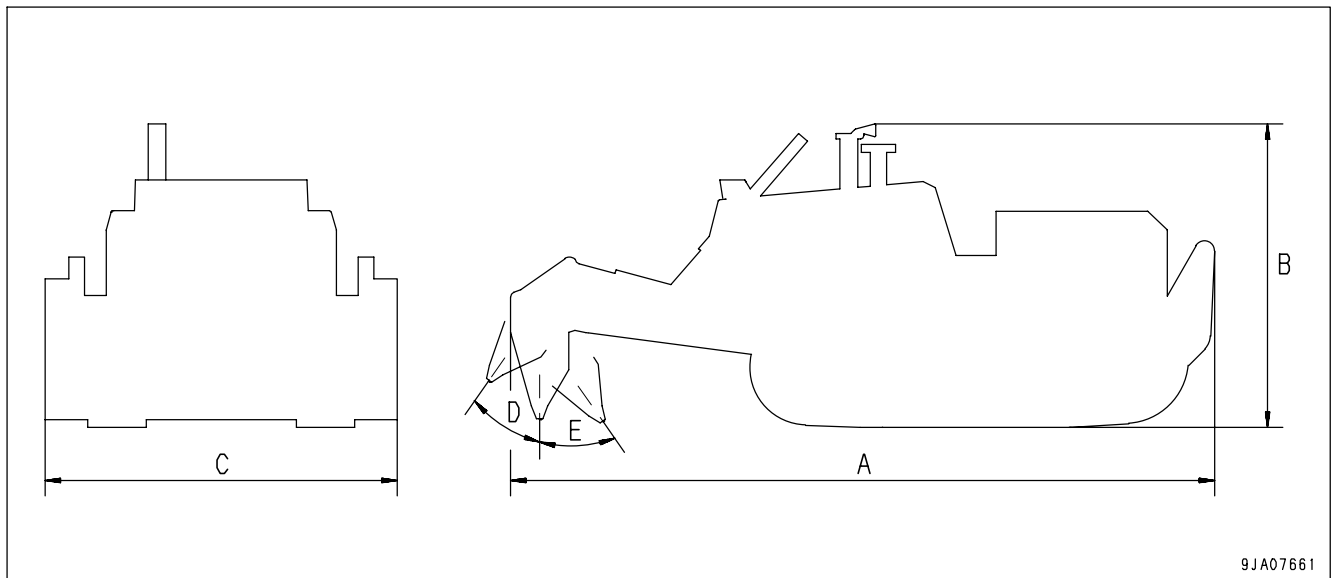

HANDLING MACHINES EQUIPPED WITH KOMTRAX

- KOMTRAX is a machine management system that uses wireless communications.
- A contract with your Komatsu distributor is necessary before the KOMTRAX system can be used. Any customers desiring to use the KOMTRAX system should consult their Komatsu distributor.
- The KOMTRAX equipment is a wireless device using radio waves, so it is necessary to obtain authorization and conform to the laws of the country or territory where the machine equipped with KOMTRAX is being used. Always contact your Komatsu distributor before selling or exporting any machine equipped with KOMTRAX.
- When selling or exporting the machine or at other times when your Komatsu distributor considers it necessary, it may be necessary for your Komatsu distributor to remove the KOMTRAX equipment or to carry out action to stop communications.
- If you do not obey the above precautions, neither Komatsu nor your Komatsu distributor can take any responsibility for any problem that is caused or for any loss that results.

BASIC PRECAUTIONS



WARNING

- Never disassemble, repair, modify, or move the communications terminal, antenna, or cables. This may cause failure or fire on the KOMTRAX equipment or the machine itself. (Your Komatsu distributor will carry out removal and installation of KOMTRAX.)
- Do not allow cables or cords to become caught; do not damage or pull cables or cords by force. Short circuits or disconnected wires may cause failure or fire on the KOMTRAX equipment or the machine itself.
- For anyone wearing a pacemaker, make sure that the communications antenna is at least 22 cm (8.7 in) from the pacemaker. The radio waves may have an adverse effect on the operation of the pacemaker.

NOTICE

- Even when the key in the starting switch of the KOMTRAX system is at the OFF position, a small amount of electric power is consumed. When putting the machine into long-term storage, take the action given in "LONG-TERM STORAGE (PAGE 3-140)".
- Please contact your Komatsu distributor before installing a top guard or other attachment that covers the cab roof.
- Be careful not to get water on the communications terminal or wiring.

REMARK

- The KOMTRAX system uses wireless communications, so it cannot be used inside tunnels, underground, inside buildings, or in mountain areas where radio waves cannot be received. Even when the machine is outside, it cannot be used in areas where the radio signal is weak or in areas outside the wireless communication service area.
- There is absolutely no need to inspect or operate the KOMTRAX communications terminal, but if any abnormality is found, please consult your Komatsu distributor.

INDEX

<A>			
ADJUSTING POSTURE OF WORK EQUIPMENT -----	3-120		
AIR CONDITIONER -----	3-	53	
ASHTRAY -----	3-	52	
			
BREAKING IN THE MACHINE -----	1-	7	
<C>			
CAP WITH LOCK -----	3-	49	
CAR STEREO, HANDLING -----	3-	60	
CHECK AFTER FINISHING WORK -----	3-126		
CHECK BEFORE STARTING ENGINE, ADJUST -----	3-	76	
CIRCUIT BREAKER -----	3-	47	
COLD WEATHER OPERATION -----	3-137		
AFTER COLD WEATHER -----	3-139		
AFTER COMPLETION OF WORK -----	3-139		
PRECAUTIONS FOR LOW TEMPERATURE -----	3-137		
CONTROL LEVERS, PEDALS -----	3-	38	
<D>			
DOOR OPEN LOCK -----	3-	51	
DOOR POCKET -----	3-	52	
<E>			
ENGINE SERIAL NO. PLATE -----	1-	8	
EXPLANATION OF COMPONENTS -----	3-	5	
EXTERNAL POWER SOURCE TYPE			
ENGINE PREHEATING HEATER -----	3-	68	
<F>			
FOREWORD -----	1-	2	
FRONT PANEL -----	3-	5	
FRONT/REAR, LEFT/RIGHT DIRECTIONS OF MACHINE -----	1-	7	
FUSE -----	3-	45	
<G>			
GENERAL PRECAUTIONS -----	2-	9	
GENERAL PRECAUTIONS -----	6-	2	
PRECAUTIONS RELATED TO SAFETY -----	6-	2	
GENERAL VIEW -----	3-	2	
GENERAL VIEW OF CONTROLS AND			
GAUGES -----	3-	3	
GENERAL VIEW OF MACHINE -----	3-	2	
GUIDES TO MAINTENANCE -----	4-	2	
<H>			
HANDLING MACHINES EQUIPPED WITH KOMTRAX -----	6-	12	
BASIC PRECAUTIONS -----	6-	12	
HANDLING OIL, FUEL, COOLANT, AND PERFORMING OIL CLINIC -----	4-	5	
HANDLING TRIMMING DOZER -----	6-	5	
EXPLANATION OF COMPONENTS -----	6-	6	
GENERAL VIEW -----	6-	5	
MAINTENANCE -----	6-	7	
SPECIFICATIONS -----	6-	11	
HEATER, HANDLING -----	3-	59	
<I>			
INSTALLATION OF CAB -----	3-131		
INSTALLATION OF ROPS -----	3-131		
INTRODUCTION -----	1-	7	
<L>			
LOADING, UNLOADING WORK -----	3-132		
LOCKING -----	3-126		
LONG-TERM STORAGE -----	3-140		
AFTER STORAGE -----	3-140		
BEFORE STORAGE -----	3-140		
DURING STORAGE -----	3-140		
<M>			
MACHINE OPERATION -----	3-104		
MAIN POWER CIRCUIT BREAKERS -----	3-	47	
MAINTENANCE SCHEDULE CHART -----	4-	16	
ADJUST INJECTOR -----	4-	18	
METHOD OF LIFTING MACHINE -----	3-135		
<N>			
NECESSARY INFORMATION -----	1-	8	
<O>			
OPERATION -----	3-	76	
OPERATIONS AND CHECKS AFTER STARTING ENGINE -----	3-100		
OUTLINE OF ELECTRIC SYSTEM -----	4-	8	
OUTLINES OF SERVICE -----	4-	5	

<P>		WHEN REQUIRED -----	4- 20
PARKING MACHINE -----	3-124	SHIFTING BETWEEN FORWARD AND REVERSE -----	3-111
PERIODIC REPLACEMENT OF SAFETY CRITICAL PARTS -----	4- 14	SHIFTING GEAR -----	3-107
POSITION OF SERVICE METER -----	1- 9	SPECIFICATIONS -----	5- 2
POWER SOURCE -----	3- 48	STANDARD TIGHTENING TORQUES FOR BOLTS AND NUTS -----	4- 13
PRECAUTIONS FOR MAINTENANCE -----	2- 27	STARTING ENGINE -----	3- 95
PRECAUTIONS FOR OPERATION -----	2- 17	STEERING MACHINE -----	3-113
BATTERY -----	2- 24	STOPPING ENGINE -----	3-103
BEFORE STARTING ENGINE -----	2- 17	SWITCHES -----	3- 34
OPERATION -----	2- 19		
TOWING -----	2- 26	<T>	
TRANSPORTATION -----	2- 23	TABLE TO ENTER SERIAL NO. AND DISTRIBUTOR -----	1- 9
PRECAUTIONS FOR OPERATION -----	3-115	TIPS FOR LONGER UNDERCARRIAGE LIFE -----	3-127
PRECAUTIONS FOR TRANSPORTATION -----	3-136	TOOL BOX -----	3- 52
PROCEDURE FOR SELECTING RIPPER POINT -----	6- 4	TORQUE LIST -----	4- 13
PRODUCT IDENTIFICATION NUMBER (PIN), MACHINE SERIAL NO. PLATE -----	1- 8	TRANSPORTATION -----	3-130
		TRANSPORTATION PROCEDURE -----	3-130
<R>		TRAVELING ON ROADS -----	3-136
RECOMMENDED FUEL, COOLANT, AND LUBRICANT -----	4- 10	TROUBLESHOOTING -----	3-141
USE OF FUEL, COOLANT AND LUBRICANTS ACCORDING TO AMBIENT TEMPERATURE -----	4- 11	AFTER RUNNING OUT OF FUEL -----	3-141
REMOVAL OF CAB -----	3-130	IF BATTERY IS DISCHARGED -----	3-144
		METHOD OF TOWING MACHINE -----	3-142
		OTHER TROUBLE -----	3-148
		<W>	
<S>		WEAR PARTS -----	4- 9
SAFETY -----	2- 2	WEAR PARTS LIST -----	4- 9
SAFETY CRITICAL PARTS -----	4- 14	WORK POSSIBLE USING BULLDOZER ---	3-118
SAFETY INFORMATION -----	1- 5		
SAFETY LABELS -----	2- 4		
POSITIONS OF SAFETY PICTOGRAMS -----	2- 4		
SAFETY LABELS -----	2- 5		
SASH GLASS INTERMEDIATE LOCK -----	3- 51		
SELECTION OF TRACK SHOE -----	6- 3		
METHOD OF SELECTING SHOES -----	6- 3		
SERVICE PROCEDURE -----	4- 19		
CHECK BEFORE STARTING -----	4- 44		
EVERY 1000 HOURS SERVICE -----	4- 56		
EVERY 2000 HOURS SERVICE -----	4- 63		
EVERY 250 HOURS SERVICE -----	4- 45		
EVERY 4000 HOURS SERVICE -----	4- 70		
EVERY 500 HOURS SERVICE -----	4- 52		
EVERY 8000 HOURS SERVICE -----	4- 74		
INITIAL 250 HOURS SERVICE (ONLY AFTER THE FIRST 250 HOURS) -----	4- 19		

D85EX-15, D85PX-15 BULLDOZER

Form No. PEN00025-02

©2007 KOMATSU

All Rights Reserved

Printed in Japan 12-07
