



**intelligent touch Manager**

Daikin *intelligent Touch Manager*
for Building Control

Application Guide





Contents

1.	Introduction	4
2.	Overview	6
3.	<i>intelligent Touch Manager</i> as a BACnet™ Client	8
3.1	System Architecture	9
3.2	Product Specifications	9
3.3	Better Integration with Daikin Applied DOAS	10
3.4	Applying <i>iTM BACnet</i> Client	10
3.5	Setup and Commissioning of <i>iTM BACnet</i> Client	11
4.	WAGO® I/O Option	13
4.1	Point Type Definitions	13
	Analog Outputs	14
	Typical Points and their Points type	15
	List of approved WAGO I/O Modules	16
4.2	Selection of a WAGO Node	17
4.3	WAGO Wiring Reference	17
5.	Daikin WAGO BACnet/IP controller	18
	Features	18
	Example: Controlling a water loop system	18
6.	Budgeting for <i>iTM</i> as a Mini-BMS	20
7.	Native <i>intelligent Touch Manager</i> Programming	22
7.1	Scheduling	22
7.2	Interlock Programming Reference	22
7.3	Email and Alarming	25
8.	WAGO Overview	26
9.	Protocol Implementation Conformance Statement (PICS) for <i>iTM BACnet</i> Client	29
10.	Appendix-1: List of Operation Data Indoor Units and Outdoor Units	31
	A. Indoor Unit Operation Data	31
	B. General Outdoor Unit Operation Data	31
	C. Outdoor Unit Operation for each condenser module*	31
11.	Appendix-2: IT Network Requirements	33
12.	Glossary	34

1. Introduction

According to a U.S Department of Energy (DOE) study in 2012, less than 10% of the buildings have a Building Management System (BMS). Over 90% of the buildings are below 50,000 Sq. Ft. Most buildings use 50-100 indoor units for comfort cooling and heating purposes. An uncontrolled building could have higher energy consumption compared to a managed building.

Buildings that are less than 10,000 Sq. Ft. in the area may prefer smart thermostat type solution and buildings that are greater than 50,000 Sq. Ft. can afford a traditional BMS. The *intelligent Touch Manager (iTM)* as mini BMS fits the 10,000 Sq. Ft. – 50,000 Sq. Ft. market segment which amounts to 22% of the buildings. Typical controls scope for a building that is less than 50,000 Sq. Ft. is shown below.

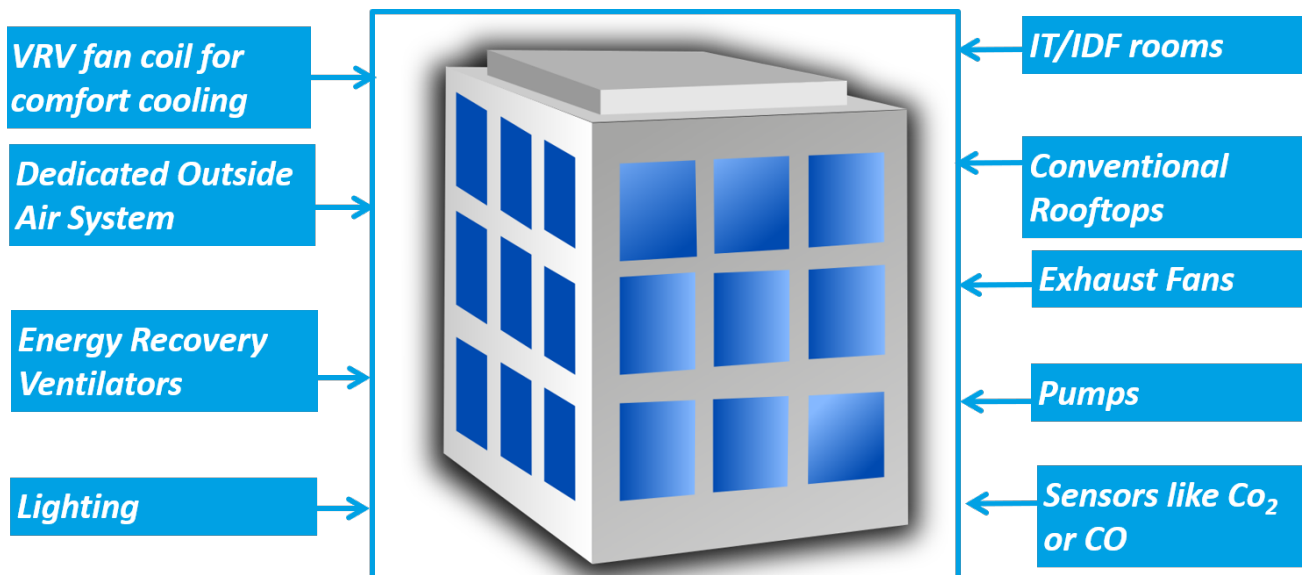
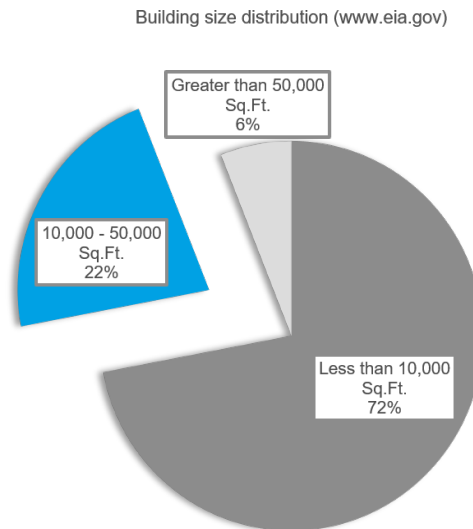

A mini-BMS in the building could control and monitor equipment such as Variable Refrigerant Volume (VRV) system, Dedicated Outside Air System (DOAS), Energy Recovery Ventilator (ERV), Exhaust Fans, Conventional Rooftops, Critical Rooms Units, IT Rooms and Lighting System. The *intelligent Touch Manager* operating as a Mini-BMS can control and monitor the equipment mentioned above with its standard features and add-on features.

The *iTM* could be a mini-BMS in the following applications

- Healthcare such as a private office or small clinics
- Lodging/hotels
- Retail (other than malls, auto dealerships, large showrooms)
- Office spaces
- Banks and credit unions
- Public order and safety
- Religious worship
- Order and safety
- Education (could also be adult learning or private/charter schools)

1. Introduction

The *intelligent Touch Manager* can control and monitor the *VRV* indoor units as well as control and monitoring of third-party units with the following options

1. BACnet™ Client Software option (PN# DCM009A51)
2. WAGO® Input and Output modules (PN# 60359653 and Modules)
3. Daikin *WAGO BACnet/IP* Controller (PN# 750-831)

This application guide describes various features and options available for the *intelligent Touch Manager* and how to apply them. Based on the application one or a combination of the above options can be used to control third-party equipment.

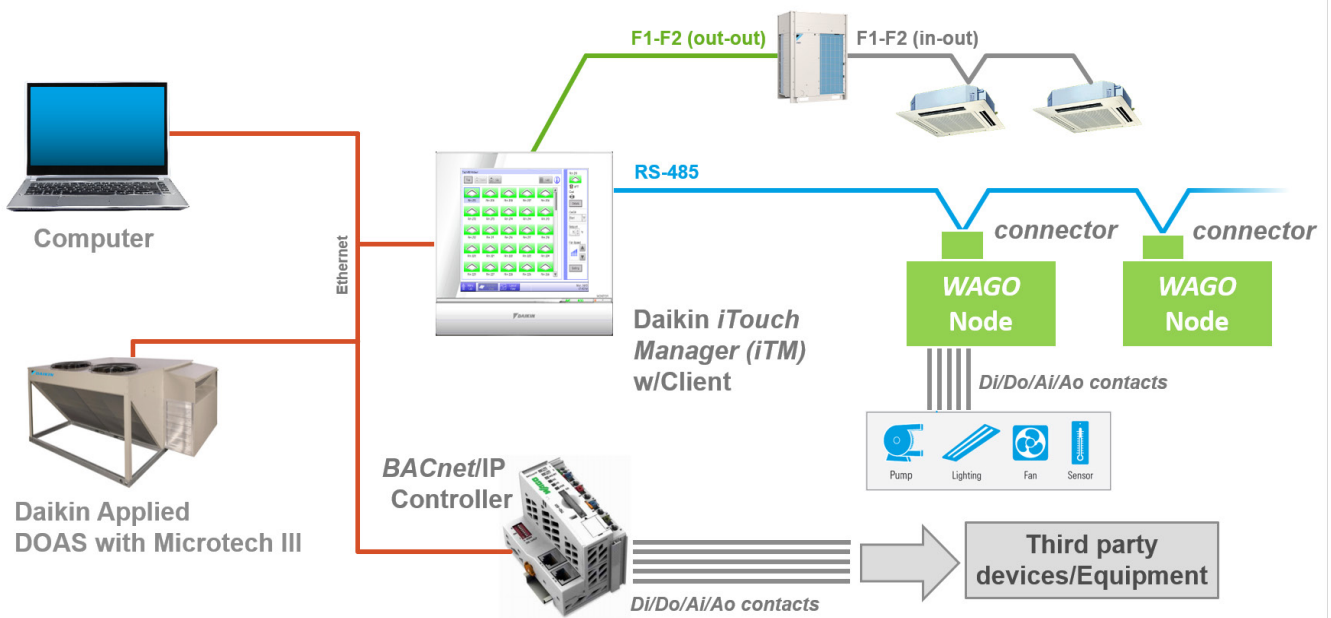

2. intelligent Touch Manager Overview



The *intelligent Touch Manager (iTM)* is an advanced multi-zone controller that controls and monitors the Daikin VRV system as well as third-party equipment. The *iTM* can provide a cost-effective mini Building Management System (BMS) solution to integrate and control third-party devices through optional software and hardware. If a BMS already exists, the *iTM* can be used as a *BACnet* gateway for BMS integration with the *iTM BACnet* Server Gateway Option.

Easy Operation and Configuration

- » Intuitive user interface with 10.4" LCD touchscreen.
- » Flexible screen views include the icon view, list view, and layout view for system configurations.
- » Easy engineering with the use of the Preset Tool and USB port.

Advanced VRV Control Logic

- » Independent Cool and Heat setpoints or Single setpoint in the occupied period.
- » Independent Setback setpoints in the unoccupied period.
- » Weekly Schedule with Optimum Start and Timed Override.
- » Auto Changeover with configurable methods.

Facility Management and Billing

- » Remote web access.
- » Automatic error and alert emails.
- » Tenant Billing with *iTM* PPD option.
- » Provide indoor unit and outdoor unit operation data for up to five days.

Mini BMS Solution with Software and Hardware Options

- » Interlock and Emergency Stop for facility management.
- » DI, DO, AI, AO points integrated via the *WAGO* I/O System.
- » *BACnet* points (AI, AO, AV, BI, BO, BV, MSI, MSO, MSV) integrated with the *iTM BACnet* Client Option.

2. intelligent Touch Manager Overview

BACnet Server Gateway Option

- » Direct connection to the VRV system using the *iTM* as a gateway.
- » Individual device ID assigned to each indoor unit and outdoor unit management point.
- » Seamless control logic integration between the *iTM* and BMS.
- » Greatly reduces the need for BMS integrator programming.

Built-in Service Tool with remote access

- » Operation data are stored in the *iTM* for the last 5 days:
 - » Indoor unit and outdoor unit operation data
 - » BACnet Client objects
 - » WAGO I/O system data
- » Operation data can be exported through a USB drive or via the *iTM* web browser remotely.
- » The BMS can monitor the BACnet objects of the indoor unit, and outdoor unit operation data with the BACnet Server Gateway Option activated.

Web function and remote monitoring

The Web function enables remote management for the Daikin VRV system with other general equipment integrated into the *iTM* so they can be accessed from a PC using a browser compatible with a flash player. Four administrators and sixty general users can be registered to access the *iTM*. Screens and operation accessible to general users can be restricted using the menu functions.

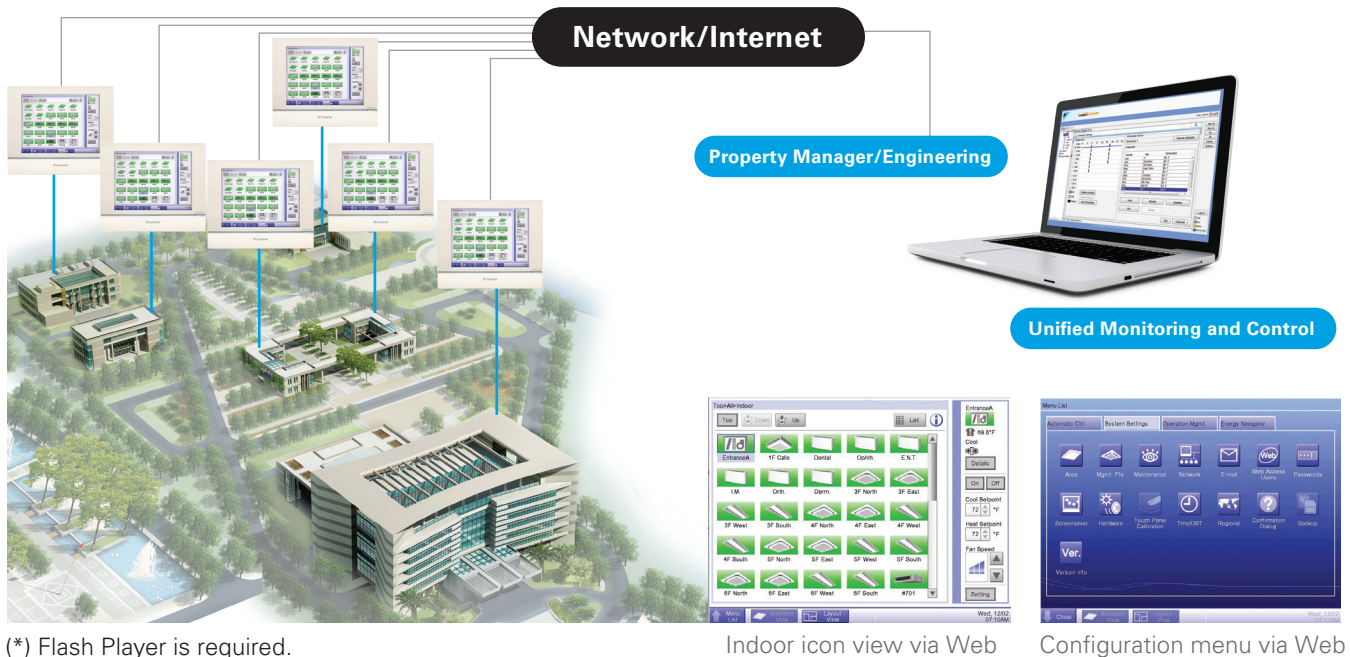

2. intelligent Touch Manager Overview

Automatic Alert/Error e-mail enables prompt response by service personnel based on timely and precise knowledge of what happened in the system at the remote site.

- » Up to 10 e-mail addresses can be set.
- » The SMTP server authentication method is selectable from no authentication, POP before SMTP, and SMTP-AUTH.

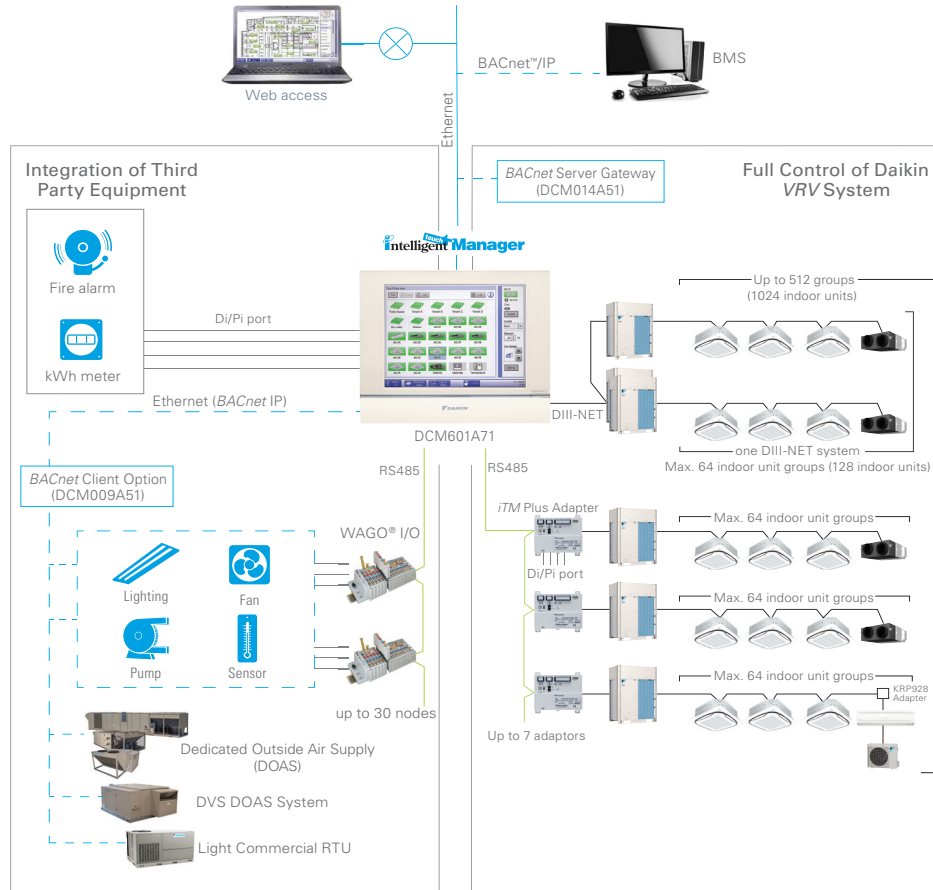

3. intelligent Touch Manager as a BACnet Client

The *iTM* offers a cost-effective solution for building management system (BMS) applications using the *BACnet* Client software option. The *iTM BACnet* Client Option (DCM009A51) provides more flexibility to enhance the *iTM*'s function as a mini BMS with *BACnet* capabilities. Using the *BACnet* Client option, the *iTM* can control and monitor a third party Dedicated Outside Air System (DOAS) and other third-party equipment using the *BACnet*/IP protocol.

- » It is a cost-effective BMS solution for small and medium-size buildings under 50,000 Sq. Ft.
- » Controls and monitors any equipment with an integrated *BACnet* IP servers such as generators, third-party air handlers, energy recovery ventilators, lighting panels, and the Daikin Zoning Kit (DZK).
- » Offers integrated control on Daikin *VRV* systems and third-party mechanical equipment.
- » Perform easy commissioning with pre-Engineering Tool
- » Add user-generated graphical user interface to *iTM* to view third-party units.
- » *iTM BACnet* Client software option reduces the need for a third-party controls integrator saving valuable project costs and reduces integration issues.
- » Able to download operation data from *VRV* indoor unit and outdoor unit and data from third-party devices connected via *WAGO* or *BACnet*.

3. intelligent Touch Manager as a BACnet Client

3.1 System Architecture:

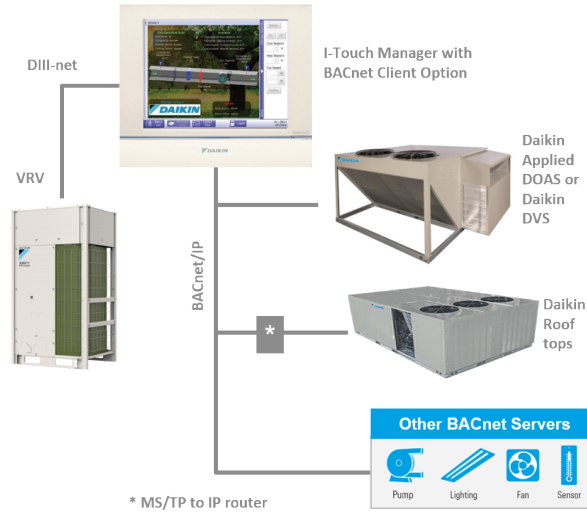

3.2 Product Specifications:

- » Communication Protocol: *BACnet/IP*.
- » Wiring for *BACnet/IP*: Requires a CAT5 Ethernet cable.
- » A maximum of 50 *BACnet* devices can be registered in one *iTM*.
- » A maximum of 512 *iTM* Management Points can be created for *BACnet* objects.
- » A maximum of 1536 *BACnet* objects can be monitored.
- » The *BACnet* Client function supports the following nine *BACnet* object types.
 - » Analog Input (7 digits)
 - » Analog Output (7 digits)
 - » Analog Value (7 digits)
 - » Binary Input
 - » Binary Output
 - » Binary Value
 - » Multistate Input (max 10 states)
 - » Multistate Output (max 10 states)
 - » Multistate Value (max 10 states)

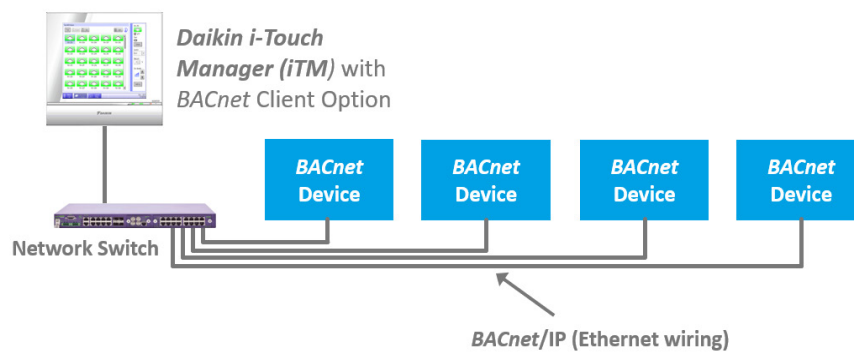

- » Use the *BACnet* Objects in schedule and interlock function of the *iTM* to control third-party units.
- » Record and monitor operation data (See Appendix).

3. intelligent Touch Manager as a BACnet Client

3.3 Better Integration with Daikin Applied DOAS:

- » By using the *intelligent Touch Manager* as the Mini-BMS better integration can be achieved with Daikin Applied DOAS compared older integration methods such as a D3-Gateway.
- » The complete equipment and control solution can be created with Daikin equipment by combining VRV and Applied Air Handlers.
- » The cost of controls can be reduced compared to having a traditional BMS.

3.4 Applying *iTM* BACnet Client

When applying the *BACnet* Client, it is important to make sure the project needs can be met with an *intelligent Touch Manager* considering the current and future needs of the building. The *intelligent Touch Manager BACnet* Client uses very common building communications protocol, i.e. *BACnet*. Designing and building a project using the *iTM BACnet* Client creates a *BACnet* ready building that is easy for a possible future integration to a full-scale BMS as *BACnet* is an open protocol. The project needs can be broadly classified into three parameters

(1) Total number of management points allowed in the *intelligent Touch Manager*

Calculate the total number of points, so it does not exceed the *iTM* limitation. The following table below can help in the calculation:

		Limit	Enter the Count
A	Indoor Unit (VRV Fan Coil, VAM, Mini-splits, FXMQ_OA)	<512	
B	<i>BACnet</i> Data Points	(All Categories combined) < 512	
	WAGO I/O Data Points		
	D3Dio, D3Di		
	Internal Management Point		
Total (A+B)		<650	

Total management points in an *iTM* should not be greater than 650.

(2) Programming complexity to achieve the sequence of operation.

Here is a list of common programming options available using *iTM*

- » Scheduling
- » Interlock Programming
- » Alarm Monitoring
- » History Logging and Trending

3. *intelligent Touch Manager* as a *BACnet* Client

The *intelligent Touch Manager* is designed to be a simple building management system and acts as a supervisory controller, and it is expected that the heavy programming is supported by the field controller (controller installed to control specific equipment) installed at the third-party equipment.

The following list provides examples of heavy programming items and these cannot be programmed at the *intelligent Touch Manager*

- » PID Loop programming.
- » Lead/Lag programming or duty cycle rotation.
- » Visualization of trend graphs.
- » Dynamic graphics.

Applications that specifically require heavy programming can be achieved by using a third-party building management system or using the Daikin *WAGO BACnet/IP* Controller. The Daikin *WAGO BACnet/IP* Controller is discussed later in the guide.

(3) The third-party equipment monitored by the *iTM* should communicate *BACnet/IP*

- » The third-party equipment should be furnished with *BACnet/IP* communication module.
- » If the device only communicates *BACnet* MS/TP, then a *BACnet* MS/TP to *BACnet/IP* router is required.
- » If the device only communicates Modbus®, then a *Modbus* to *BACnet/IP* router is required
- » If the device uses only input and output contacts for control, then *WAGO* I/O or Daikin *WAGO BACnet/IP* Controller may be required.

3.5 Setup and Commissioning of *iTM BACnet* Client

To setup the *iTM* as a *BACnet* client, the option has to be activated using the activation code. Once the *BACnet* Client software has been activated at the *intelligent Touch Manager*, the external *BACnet* devices can be integrated. The point mapping is performed by downloading a .CSV (comma-separated value file) using a USB drive. The .CSV file is edited by using Microsoft Excel software. The points mapping can be created remotely saving precious on-site time.

- » The third-party equipment should be furnished with a *BACnet/IP* communication module
- » If the device only communicates *BACnet* MS/TP, then a *BACnet* MS/TP to *BACnet/IP* router is required.
- » If the device only communicates Modbus®, then a *Modbus* to *BACnet/IP* router is required.
- » If the device uses only input and output contacts for control, then *WAGO* I/O or Daikin *WAGO BACnet/IP* controller may be required.

Daikin also offers Microsoft Excel-based tools to create the point mapping file. The tools save time compared to creating the excel file manually. The Microsoft Excel tools (*iTM BACnet* Client Macro Tools) can be downloaded from www.Daikincity.com, and the tools are provided along with instructions on how to use them.

3. intelligent Touch Manager as a BACnet Client

Graphics screens can also be added to the *intelligent Touch Manager* to display the equipment.

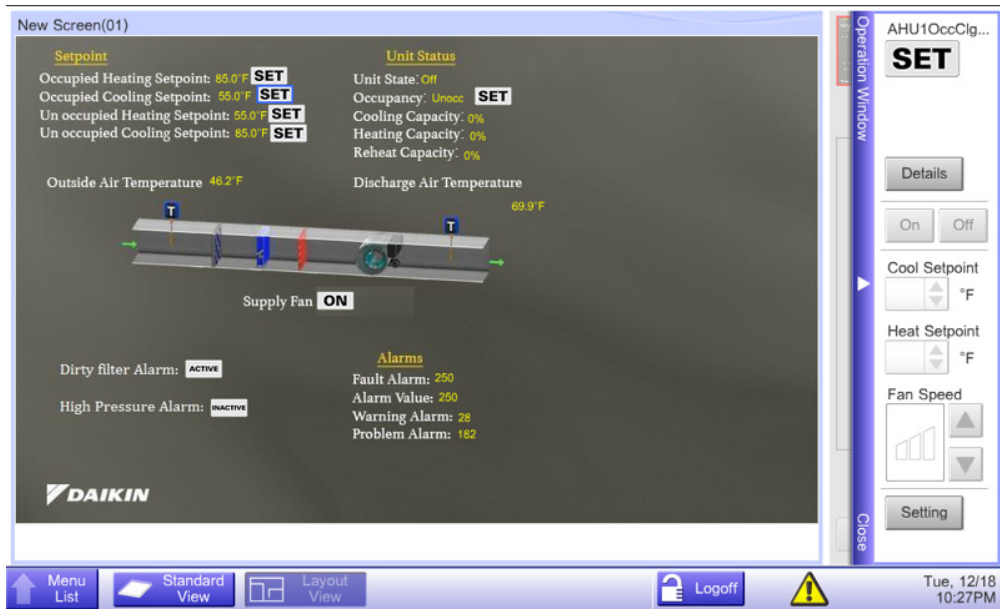

The graphics screen can be custom created or created from templates (*iTM BACnet Client GUI Templates*) that are available to download from the www.Daikincity.com.

The following flow chart shows basic steps involved in the commissioning of the *intelligent Touch Manager* with the *BACnet Client* option,

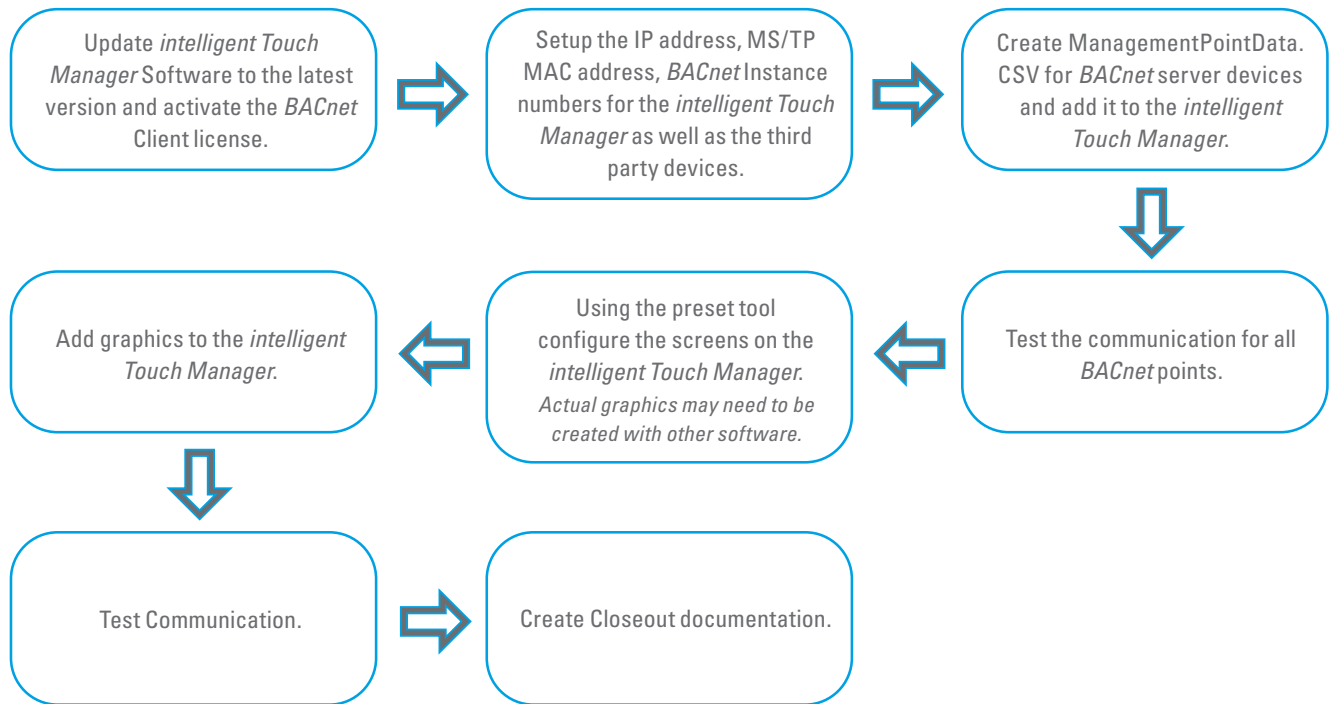

For the startup of *iTM BACnet Client*, it is essential that a startup technician is familiar with the entire project and equipment that are being integrated. Note that the equipment could come from multiple vendors and there may be other startup personnel involved; project coordination is paramount.

4. WAGO I/O Option

WAGO I/O integrates ancillary equipment into the *intelligent Touch Manager (iTM) DCM601A71* with the use of Digital Input (DI), Digital Output (DO), Analog Input (AI) and Analog Output (AO) signals. It provides monitoring and control of non-Daikin equipment via manual control, interlock, scheduling, and remote access using the *iTM*'s touchscreen or web access.

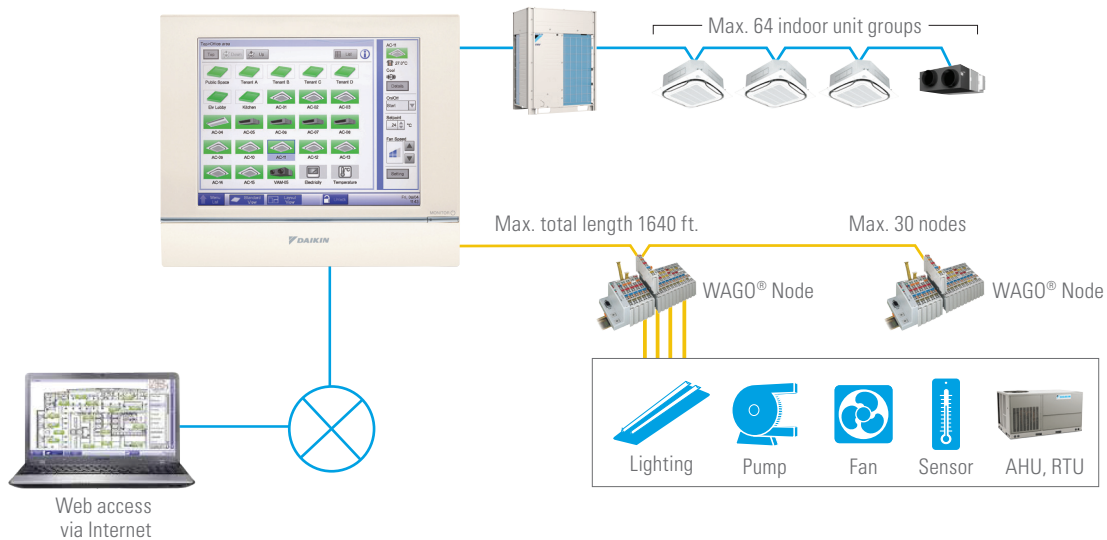

- » Connect various sensors to WAGO I/O modules such as Analog Inputs, Analog Outputs, Digital Inputs, and Digital Outputs.
- » The WAGO node can connect up to 120 contacts or hardwired points.
- » Up to 30 WAGO nodes can be connected to an *intelligent Touch Manager*. However, please note that an *intelligent Touch Manager* can monitor only 512 WAGO points.

4.1 Point Type Definitions

Digital Input

- » A Digital Input is used to monitor status as either 'on' or 'off,' i.e., contact status. It is a confirmation of unit operation. For example, A switch is either open or closed; A Fan status can be 'On' or 'Off'; A Room is Occupied or Unoccupied
- » Use Digital Input points to monitor status (Status Object) and alarms (Error Object).

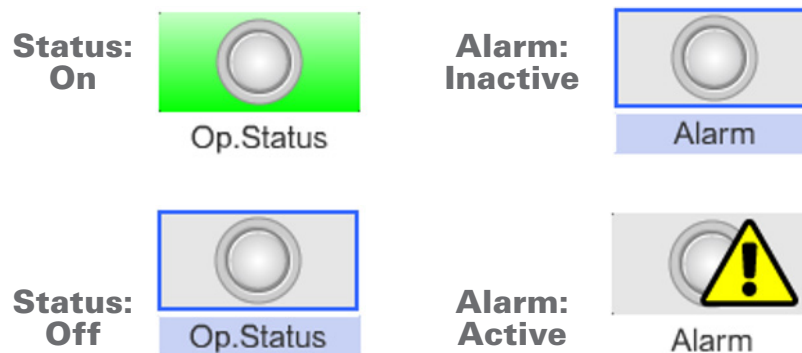

- » Common Digital Input signals are occupancy sensor and current switch.

4. WAGO I/O Option

Digital Output

- » A Digital Output is used to command a point either to 'turn the unit on' or 'turn the unit off,' i.e., contact cycling. Example, A Fan is commanded ON or OFF; A light is turned ON or OFF
- » Use Digital Output to command ON/OFF for other equipment



- » Common Digital Output signals include: Fan Start/Stop, Pump Start/Stop, and Lights On/Off.

Analog Input

An Analog Input is a signal that represents a continuous time-varying quantity (It is a point that is represented by a number) such as humidity, CO₂, and temperature:

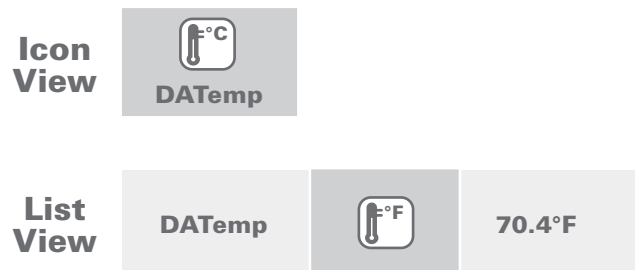

Analog Output

An Analog Output is a command signal that represents a continuous time-varying quantity (It is a point that is represented by a number) that is used to send values such as Temperature Setpoint, Pressure Setpoint, Damper position, Fan Speed.



4. WAGO I/O Option

Typical Points and their Points type

Point	Point Type
Temperature (Example: Space Temperature, Outside Air Temperature, Return Air Temperature, Discharge Air Temperature, Entering Water Temperature, Leaving Water Temperature)	Analog Input
Carbon Dioxide	Analog Input
Relative Humidity	Analog Input
Carbon Monoxide	Analog Input
Pressure (Example: Outside Air Pressure, Building Pressure, Duct Static Pressure, Differential Pressure)	Analog Input
Occupancy Sensor	Digital Input
Fan Status	Digital Input
Door Switch	Digital Input
Generic Alarm Contact	Digital Input
Fan Start/Stop (Example: Exhaust Fans, Supply Fans)	Digital Output
On/Off Command (Example: Lights On/Off, ERV On/Off, MAU On/Off)	Digital Output
2-position Damper or Valve	Digital Output
Modulating Damper or Valve	Analog Output
VFD Speed Command	Analog Output

4. WAGO I/O Option

List of approved WAGO I/O Modules:

	Item	Note	Part
Required	Daikin <i>iTM</i> Basic Kit	24 VDC Power Supply Unit, Connector, Bus Coupler, End Module	60359653
Digital Input	2 Channel Di Module		750-400
	4 Channel Di Module		750-432
	8 Channel Di Module		750-430
Digital Output	2 Channel Do Module		750-513/000-001
	4 Channel Do Module		750-504
Analog Input (Commonly Used Modules)	2 Channel Ai Module	4-20 mA	750-454
	2 Channel Ai Module	±10 VDC	750-479
	2 Channel Ai Module	20KΩ Thermistor	750-461/020-000
	4 Channel Ai Module	4-20 mA	750-455
	4 Channel Ai Module	±10VDC	750-459
	4 Channel Ai Module	10/20 K(Ohm) Thermistor	750-464/020-000
Analog Output	2 Channel Ao Module	0-10VDC	750-550
	2 Channel Ao Module	4-20 mA	750-554
	4 Channel Ai module	0-10 VDC	750-559
	4 Channel Ai module	4-20 mA	750-555
Internal Bus Power Supply	24 VDC Power Supply	Required every 32 contacts	750-613
Passive Power Supply	24VDC Power Supply		750-602
Power Jumper	24VDC Power Jumper	Field Side Connection Module For use with the 750-430 8 channel DI	750-603
Analog Input (Additional Modules)	2 Channel Ai Module	Pt100/RTD	750-461
	4 Channel Ai Module	Pt100/RTD	750-460
	2 Channel Ai Module	Pt1000/RTD	750-461/000-003
	4 Channel Ai Module	Pt1000/RTD	750-461/000-003
	2 Channel Ai Module	Ni100/RTD	750-461/000-004
	2 Channel Ai Module	Ni1000 TK6180/RTD	750-461/000-005
	4 Channel Ai Module	Ni 1000 TK 6180/RTD	750-460/000-005

4. WAGO I/O Option

4.2 Selection of a WAGO Node

The appropriate WAGO nodes can be selected by using the WAGO selection software; available to download from www.daikincity.com website. The WAGO selection tool comes with instruction on how to use along with the tool. Additionally, how to use videos can be accessed by using Daikin's training system.

4.3 WAGO Wiring Reference

Description	Type	Size	Length
Communication wiring between the <i>intelligent Touch Manager</i> and the WAGO nodes	Stranded copper plenum rated cable; CPEV or FCPEV	24 AWG – 18AWG	1640 ft
Individual IO wiring	Stranded copper plenum rated cable; CPEV or FCPEV	24 AWG – 18AWG	DI/DO: 500ft AI/AO (0-10VDC or 2-10VDC) * = 50Ft – 150Ft AI/AO (4-20mA) * = 250Ft – 500Ft

*Voltage loops have lower wiring lengths because there is a voltage drop associated with longer wiring length thus creating a signal loss.

Typically wiring schematics for WAGO and its IO module in AutoCAD format can be downloaded from www.daikincity.com website.

5. WAGO BACnet/IP controller

Daikin WAGO BACnet/IP Controller is a custom programmed controller that can be used when the *intelligent Touch Manager* interlock is not capable of meeting the programming requirement. This controller can also be used in place of a third party DDC controller depending upon the application. The custom programming for the controller is made easy as the factory performs programming. This controller is ideal for small and medium projects with a complicated custom sequence of operation.



Features

- » The Daikin WAGO BACnet/IP controller can be custom programmed to control external equipment or system based on custom sequences, such as custom AHU or water loop.
- » The controller provides the two major following functionalities:
 - » Application server: Can be controlled by a third party BMS or by the *intelligent Touch Manager* with BACnet Client Option.
 - » Application client: Can control and monitor other BACnet controllers using the BACnet network communication.
- » The controller can also be programmed to function as a standalone controller without the BACnet BACnet/IP communication.

The controller can handle up to 1,000 BACnet points.

- » Connect up to 64 Inputs and Outputs (a combination of Analog Inputs, Analog Outputs, Digital Inputs, and Digital Outputs).
- » Programmable features include multiple PID loops, staging sequence, lead-lag, duty time rotation, schedule function, alarms, trending, data logging, etc.
- » Custom programming adds flexibility to the project's sequence of operation.

The Daikin WAGO BACnet/IP Controller is commonly used for custom design AHU and water loop control when water-cooled VRV is used in a project. The Daikin WAGO BACnet/IP Controller can be used as a BACnet server or a BACnet client providing programming versatility.

This controller's BACnet points can be monitored and controlled by using the *intelligent Touch Manager* BACnet Client. The controller's onboard SD card allows custom programming with an optional trending feature.

Example: Controlling a water loop system (see on page 20)

When using the water-cooled VRV system, most projects require the additional scope to control other waterside equipment.

5. WAGO BACnet/IP controller

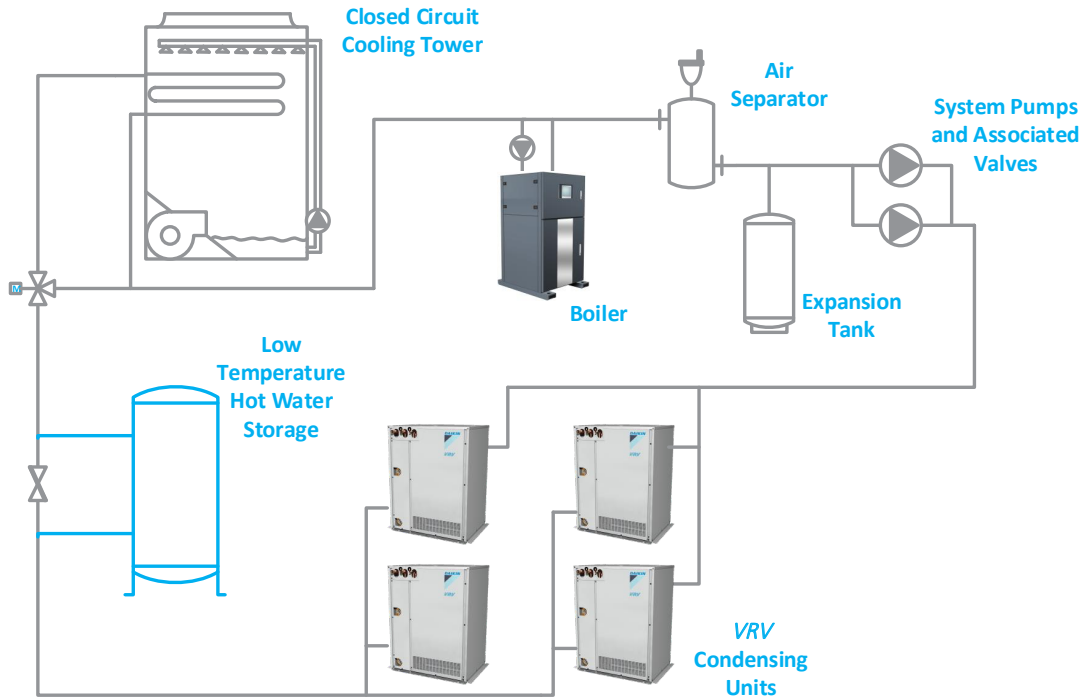

The Daikin *BACnet/IP* Controller can be used to control the

- » Loop temperature
- » Lead/Lag pump control
- » Boiler control
- » Dry cooler or fluid cooler control
- » Pump speed control
- » Cooling tower control

The following documentation is available from Daikin after an order is placed,

1. Pricing estimates for programming
2. *WAGO* hardware selection and node configuration
3. Reference wiring diagrams
4. Controller programming document which includes a specified sequence of operation and bill of materials.
5. *intelligent Touch Manager BACnet* configuration file
6. Startup documentation

Things to consider when selecting the *WAGO BACnet/IP* controller for your project,

1. Most applications if not all require additional field devices such as sensors, relays, switches, etc. These can be purchased through local distributors or online retailers.
2. The controller and its I/O modules must be mounted in a panel box; typically, the panel box is required to be built at a UL rated shop.
3. Installation and wiring of the controllers
4. Installation and wiring of field devices (such as sensors, actuators) to the controller is provided by others.
5. Creating contract drawings for the project (Daikin does not perform this).
6. Field commissioning time and site visits to troubleshoot the problem by commissioning technicians.

The field technician commissioning the *WAGO BACnet* Controller is recommended to have taken training classes offered by Daikin.

6. Budgeting for *iTM* as a Mini-BMS

When budgeting for a project with the *iTM* as a Mini-BMS be sure to consider items mentioned below.

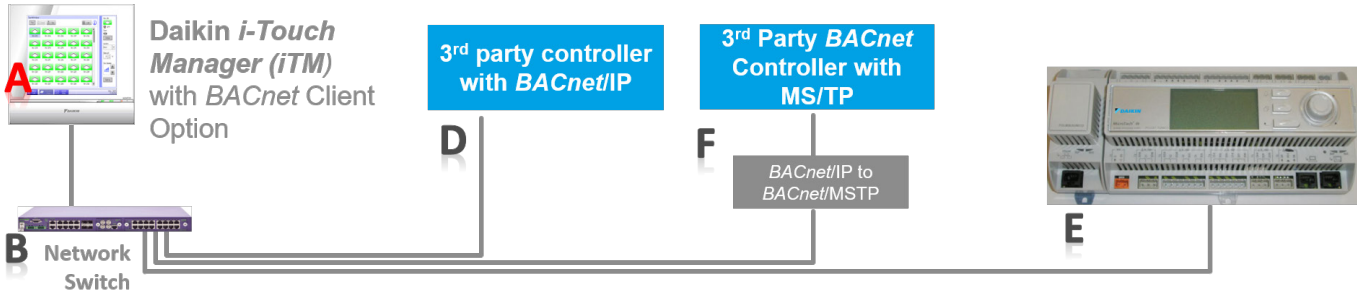

#	To be provided for the project
A	<p><i>intelligent Touch Manager</i> with the <i>BACnet</i> Client Option</p> <ol style="list-style-type: none"> <i>intelligent Touch Manager</i> DCM601A71 <i>intelligent Touch Manager</i> <i>BACnet</i> Client software option DCM009A51 24VAC Power Supply Panel Box
B	<p>Network Switch (Field Provided)</p> <ul style="list-style-type: none"> If the <i>intelligent Touch Manager</i> ties into the building, then typically there is no need for a field provided switch. The building's IT department will provide the required parts. If a standalone network is created for building's controls equipment, then a field provided switch is required, <ul style="list-style-type: none"> The switch is available from a local electronics store or online electronics store. The size of the switch is selected based on many units to be connected to the <i>BACnet/IP</i>.
C	<p><i>BACnet/IP</i> or Ethernet Cable</p> <ul style="list-style-type: none"> Each <i>BACnet</i> device should have a CAT 5 Ethernet cable (field provided) between the device and the network switch. Do not use power over Ethernet cables. Each Ethernet cable segment cannot be greater than 328ft.
D	<p>3rd party <i>BACnet/IP</i> controller</p> <ul style="list-style-type: none"> The 3rd party Rooftop Unit (RTU) and 3rd party Dedicated Outside Air System (DOAS) units that have a controller should be furnished with <i>BACnet/IP</i> communication capability. Please note: For the third-party controller the <i>BACnet/IP</i> communication may be an add-on option, please check with the supplier of the third-party controller.
E	<p>Daikin <i>Rebel</i>, <i>Maverick</i> or <i>DVS</i>,</p> <ul style="list-style-type: none"> The factory furnished Microtech III controller will need a <i>BACnet/IP</i> communication module Part number: 090016709. Select the communication module from the Daikin Selection Tool.

6. Budgeting for *iTM* as a Mini-BMS

F	<p>3rd party controller with <i>BACnet</i>/MSTP option only</p> <ul style="list-style-type: none"> • A controller that only has a <i>BACnet</i>/MSTP option will require the use of third-party <i>BACnet</i> MS/TP to <i>BACnet</i>/IP router. • <i>BACnet</i>/IP to <i>BACnet</i>/MSTP is available thru following the 3rd party manufacturers (please check with manufactures for current part number & compatibility) <ol style="list-style-type: none"> 1. Contemporary controls PN# BASRT-B 2. KMC PN# BAC5051-E
G	<p>Estimate for <i>WAGO</i> I/O option</p> <ul style="list-style-type: none"> • <i>WAGO</i> selection: The <i>WAGO</i> parts can be selected by using the <i>WAGO</i> selection Tool. • Panel or Enclosure • Inputs and Output Wiring • Communication Wiring • Field Devices – Including sensors, transmitters, and damper motors, etc.
H	<p>Estimating for Daikin <i>WAGO</i> <i>BACnet</i>/IP Controller</p> <ul style="list-style-type: none"> • <i>WAGO</i> selection: Bill of materials is provided by Daikin controls department • Programming Cost: Programming cost estimate is provided by Daikin controls department • Panel or enclosure • Inputs and Output Wiring • Field Devices – Including sensors, transmitters, and damper motors, etc. • Startup and commissioning
I	Field commissioning and startup time

Panel Box or Enclosure

A panel box or enclosure is used to house control components such as a *WAGO* Controller, its power modules, and power supply. This panel box is field provided. It is also common for the *intelligent Touch Manager* to be mounted on the door. If only the *WAGO* Controller is placed inside the enclosure, then a 6-inch depth panel box is used. If the *intelligent Touch Manager* is mounted on the door, along with the *WAGO* Controller, then the 8-inch enclosure is used. Make sure to check the NEMA rating required for the panel enclosure. Based on the local code it may be required that the panel be built-in UL rated shop. The below list provides common items that are housed in a panel other than *WAGO* and *intelligent Touch Manager* accessories.

- (1) Power supply
- (2) Terminal Blocks
- (3) Surge Protector
- (4) Disconnect
- (5) DIN RAIL
- (6) Backplate
- (7) Panduit
- (8) Relays

7. Native *intelligent Touch Manager* Programming

7.1 Scheduling

The *intelligent Touch Manager* offers 4 different Schedule types to easily schedule a unit or system: 7 days, Weekdays + Saturday + Sunday (5+1+1), Weekdays + Weekends (5+2), Every day.

The screenshot shows a software window titled "New Schedule 001". It has four tabs: "Properties", "Weekly Pattern", "Special Day Pattern", and "Calendar". The "Properties" tab is active. Inside the window, there is a "Name" field with the text "DOAS Schedule" and a "Modify" button to its right. Below this is an "Activation" section with two radio buttons: "Enable" (which is selected) and "Disable". Underneath is a "Weekly Pattern" section with four radio buttons: "7 Days", "Weekday+Saturday+Sunday", "Weekday+Weekend" (which is selected), and "Everyday". At the bottom right of the window are "OK" and "Cancel" buttons.

The *iTM*'s offers rolling holiday function can be used with *BACnet* points. Example: July 4th Every year can be set as a holiday.

7.2 Interlock Programming Reference

Interlock programming provides automated control of third-party equipment as well as *VRV* indoor units. The interlock programming can be created between indoor unit management points, *BACnet* management points, and *WAGO* managements; any of these points can be used either as an input or an output. A maximum of 500 interlock programs can be created. These interlock programs can be simple or complex depending on the application. Below is an example of a simple interlock condition:

Turn on the FCU -1 and FCU -2 if any of the lights 1A, 1B, 2A, 2B on the second floor is turned on for 60 seconds

7. Native *intelligent Touch Manager* Programming

Format of an interlock condition,

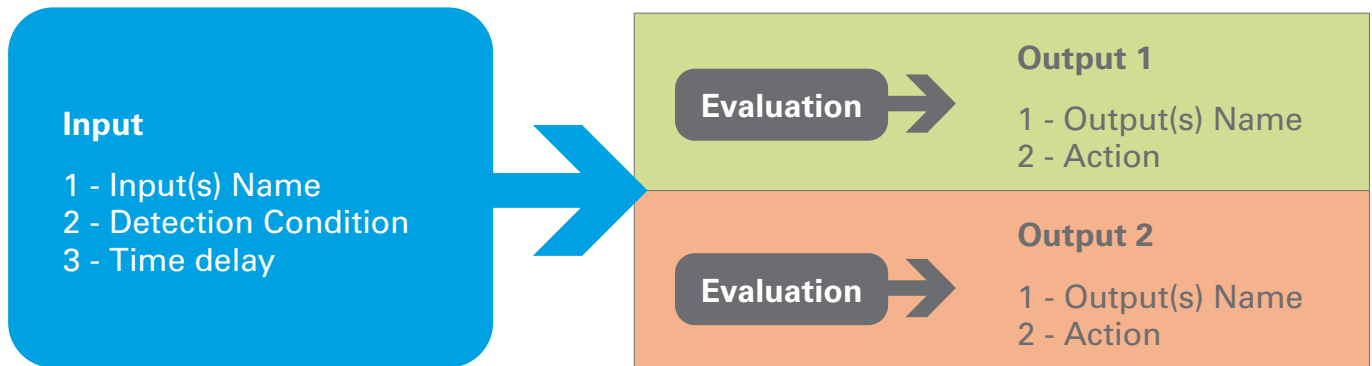

- » Input Management Points: One or more management points can be added as the input to the interlock condition so its status can be used as a condition in the interlock.
- » Detection Condition: Detection condition specifies the condition the input management has to satisfy to trigger the interlock condition.

Types of detection condition:

- » Switch: Detects On/Off status of the management point
 - » Equipment Error: Detect error status of management point when configured.
 - » Analog lower/upper limit error detects the upper limit or lower limit error condition of an analog input.
 - » Operation Mode: This condition only applied to indoor unit management points to detect the operation mode of the indoor unit.
 - » Analog Value: This condition uses an analog value as a detection condition for other analog values. The condition can be a constant value or any analog management point.
- » Time Delay: Specify the time delay for the duration that the input condition should be continuously valid before the interlock is a trigger. The setting ranges from 0 minutes to 30 minutes in a 1-minute interval. For analog values, 1 minute is the minimum setting.
- » Evaluation: This setting determines how all the inputs are evaluated, the below are the settings available,
- » At least one input becomes valid.
 - » All inputs become valid.
 - » At least one input becomes invalid.
 - » All inputs become invalid.
- » Output 1: One or more management points can be added as the output to the interlock condition so its value can be changed per the action set.
- » Output 2: This is an optional setting; typically used to reverse the interlock's actions.
- » Action: Specify the action to be taken for the management point based on interlock,

Example:

- » ON/OFF, mode, Setpoint, RC Prohibits for indoor unit management points.
- » On/Off for digital outputs or binary output
- » Set a specific value for analog outputs

7. Native intelligent Touch Manager Programming

Now looking back at the example above, the interlock can be described by the below figure:

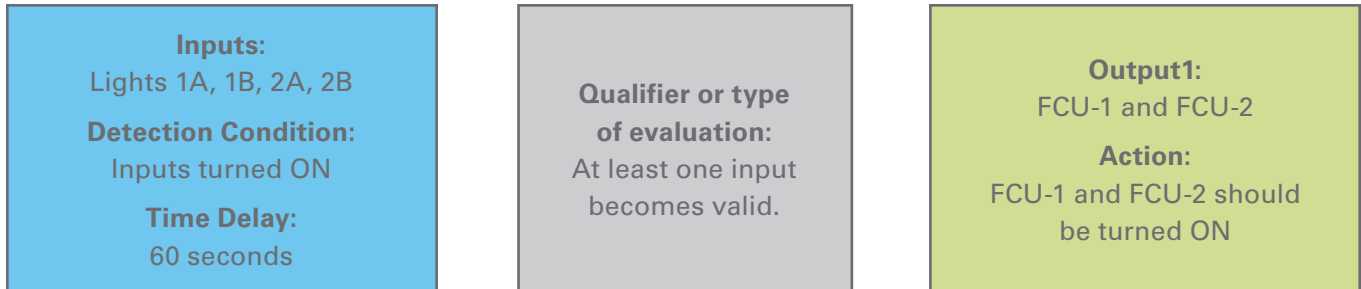

The below diagram shows the interlock programmed on the *intelligent Touch Manager*.

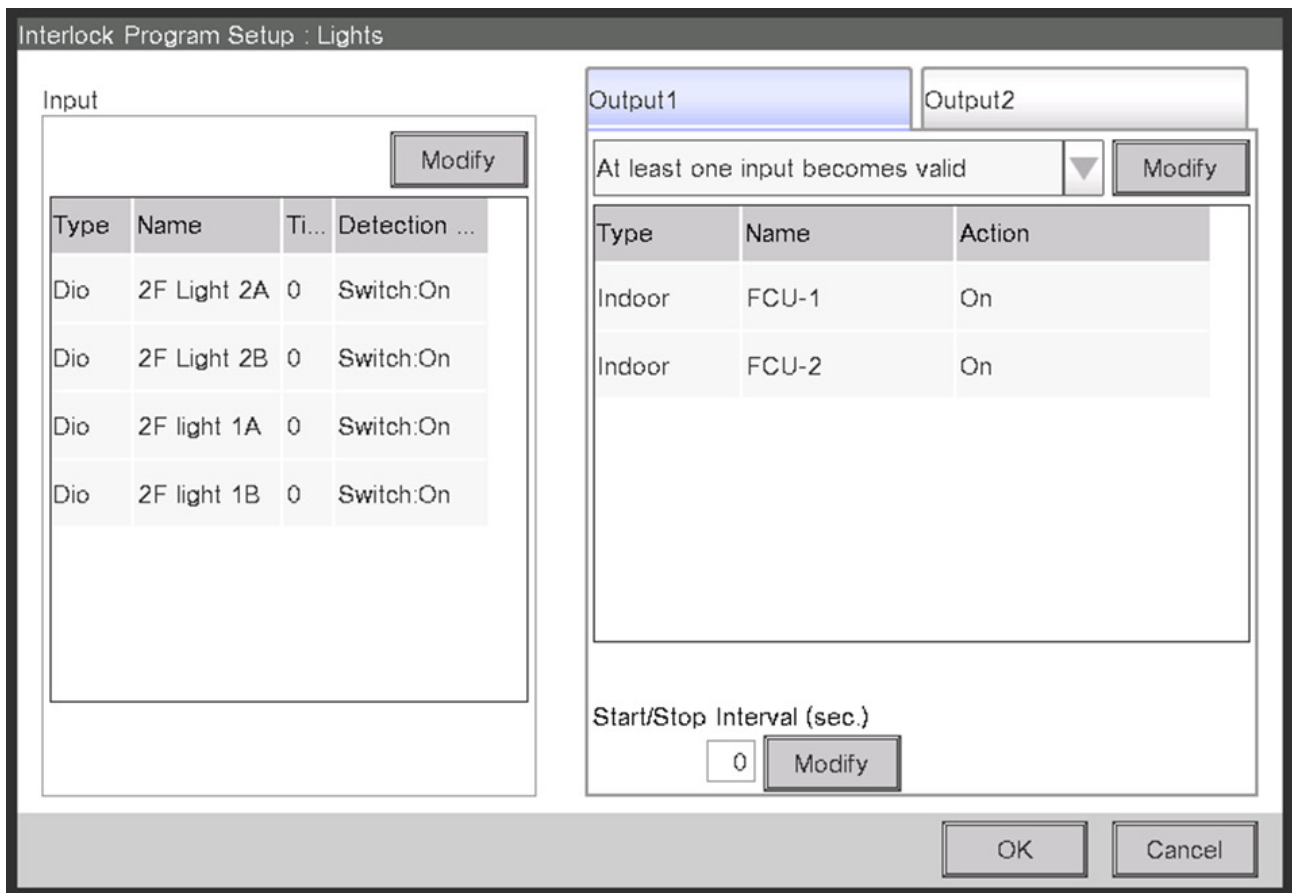

Examples of various interlock programs

- » When the Lights are ON, turn on the corresponding indoor unit.
- » When the indoor unit status is OFF, turn OFF the lights.
- » When the outside air temperature is below 50°F, and the indoor unit is in error, turn on the emergency radiant heater.
- » When the CO₂ level is greater than 1000ppm, turn on the exhaust & supply fans.
- » When the outside air temperature drops below the predetermined setpoint, enable economizer.
- » When CO₂ values generate an upper limit error, turn on exhaust & supply fans
- » When the indoor units are ON and in heating mode, enable humidifiers to maintain humidity setpoint.

7. Native *intelligent Touch Manager* Programming

Interlocking Analog Output

The programming for Analog Output signal using the *intelligent Touch Manager* is limited. The interlock only allows the analog output to be set to a specific value, hence only step control can be achieved; there is no advanced controls logic such as PID. There is a one-minute time delay when Analog Inputs are used in the input condition of the interlock.

Here is an example sequence of operation of step control interlock; (multiple interlocks are required for the below example),

- Two steps with modulating OA Damper:** When CO₂ is greater than 900ppm; set the OA damper position to 100%. If the CO₂ drops below 500ppm; set the OA damper to 50%.
- Three steps with OA Damper:** The conference room CO₂ level is monitored using a CO₂ sensor. If the CO₂ is higher than 800 ppm, open the OA damper to 50%, and if the CO₂ level is still higher than 800ppm for 5 minutes, open OA damper to 100%. If the CO₂ level is less than 500 ppm for at least 5 minutes, the damper shall be at a minimum position of 20%.
- Two steps with variable fan speed:** When CO₂ is greater than 900ppm, set the fan speed to 100%. If the CO₂ drops below 500ppm; set the fan speed to 50%.

Total interlock timing is approx. 1 minute and 40 seconds when Analog Inputs are used in detection conditions

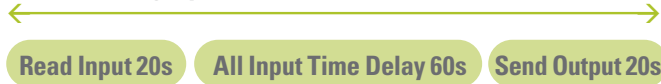

Total interlock timing is approx. 40 seconds when Digital Inputs are used in detection conditions



Typical interlock could take 40 seconds to execute.

If it is determined that an advanced programming sequence of operation is required, then Daikin *WAGO BACnet/IP* Controller is required.

7.3 Email and Alarming

- The *intelligent Touch Manager* monitors alarms and warning for *VRV*, *BACnet* points, *WAGO I/O* points.
- The *iTM* can send out email alerts of alarms occurring in the system. With the correct network settings, the *iTM* can send an E-mail containing the date/ time of occurrence, error code, and other information to predefined E-mail addresses if an equipment error or analog upper/lower limit error occurs in a management point.
- Additionally, the *intelligent Touch Manager* logs all errors occurring in the system for review later. The history file which is downloadable by a USB or by remote access can contain up to 500,000 items. An example of history is shown to the right.

ERROR

Time	Type	History ...	Contents	Name
05:45...	Error	B020	Analog lower limit ...	spacetemp
05:43...	Status	B104	Fan speed change...	1:4-14
05:43...	Cont...	A011	Logged in(10.169...	d
05:42...	Status	B102	Operation mode c...	1:4-14
05:42...	Rele...	B024	Communication re...	1:4-14
05:41...	Rele...	B032	Communication re...	Start
05:41...	Rele...	B032	Communication re...	Fan Only

8. WAGO Overview

The WAGO node consists of an *iTM* Basic Kit which includes a power supply, BUS coupler, connector, and an end module, I/O modules are added to the node based on the application requirement. A WAGO node can also be created with WAGO BACnet/IP Controller, end module, and I/O modules.

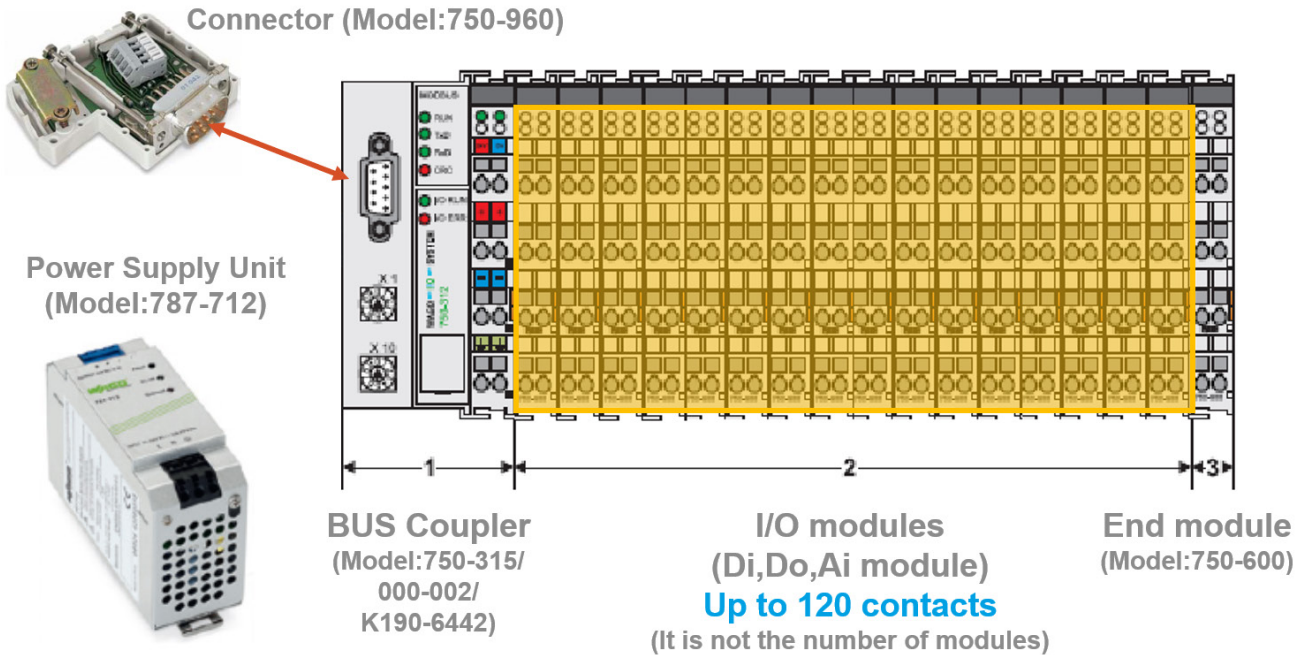

The WAGO is powered using a 24VDC power supply. The power supply part number is 787-712; it supplied by Daikin either as a part of *iTM* basic kit (PN# 60359653) or separately when using it with the WAGO BACnet/IP Controller. The WAGO controller mounts to a 35mm DIN RAIL system so that it can mounted in a field provided panel.

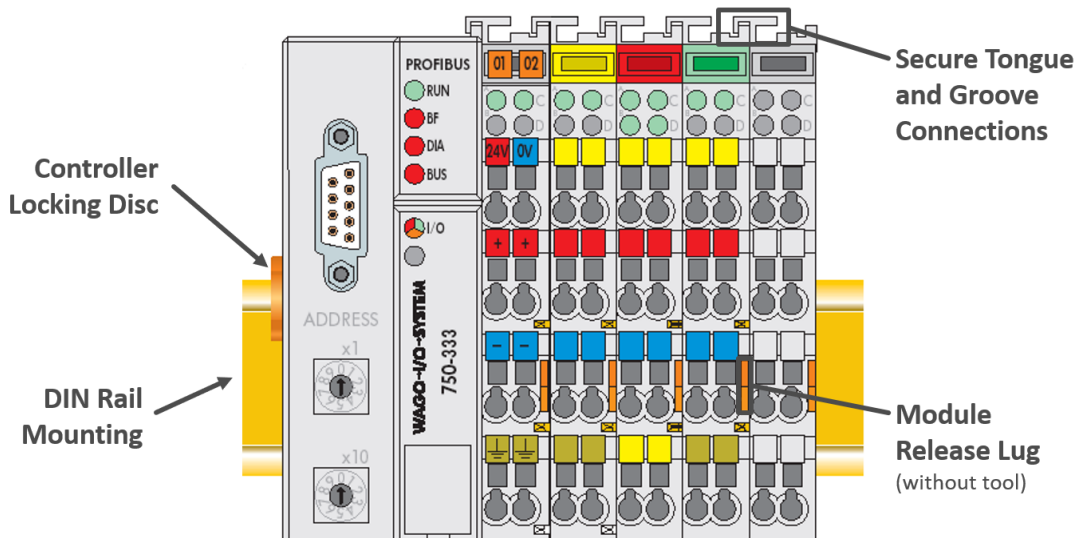

Components of an I/O module include status LED, markers, K-bus contacts, power jumper contacts, and cage clamp connections

8. WAGO Overview

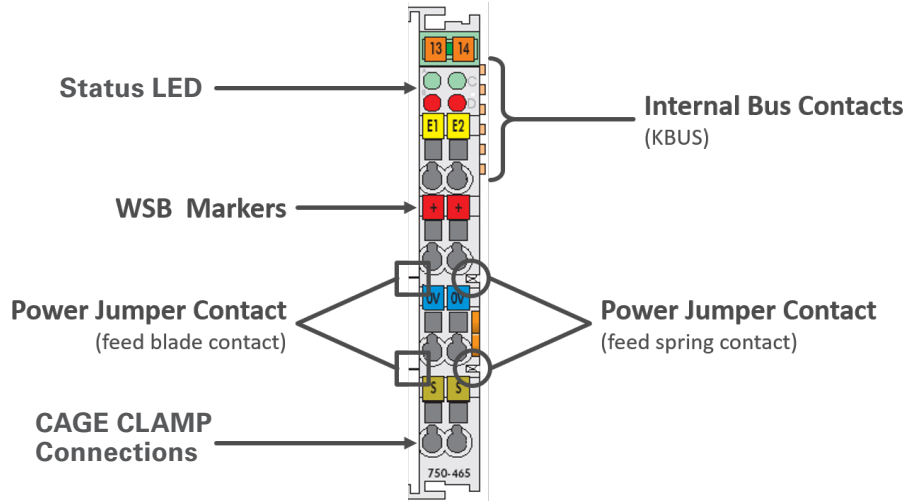

Power jumper contacts consist of blade and spring contacts built into the sides of modules. Depending on the module type and features, the contact configuration varies.

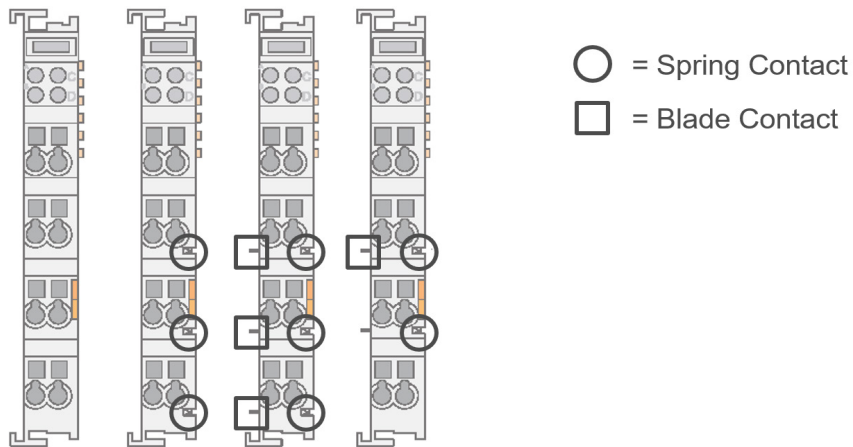

Power jumper contacts of adjacent I/O modules must be compatible (i.e., blade contacts must have corresponding spring contacts)

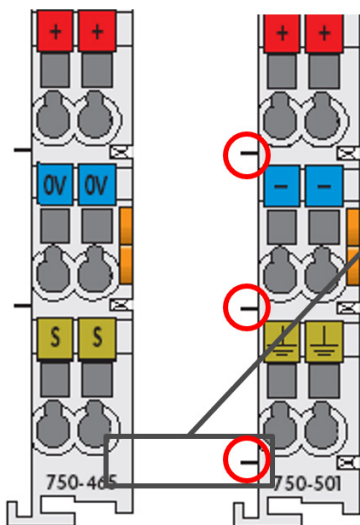

PROBLEM

These two modules cannot be adjacent to each other as shown. The left module does not have a lower spring contact for the right module's lower blade.

SOLUTION

Rearrange the node to remove this incompatibility (swap modules) or insert a supply module between them. A supply module has 0 blade contacts and 3 spring contacts.

8. WAGO Overview

Communication between the Fieldbus coupler/controller and the I/O modules as well as the system supply of the I/O modules is carried out via the internal bus. It is comprised of 6 data contacts, which are available as self-cleaning gold spring contacts. To avoid soiling or scratching, do not lay the I/O modules on the gold spring contacts.

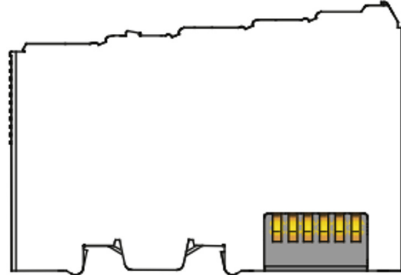

Landing wires on a WAGO module:

All modules use WAGO CAGE CLAMP connections. This connection is appropriate for solid, stranded, and fine stranded conductors. Each clamping unit accommodates one conductor. The WAGO CAGE CLAMP connections provide fast and easy wiring. The connections are vibration resistant.

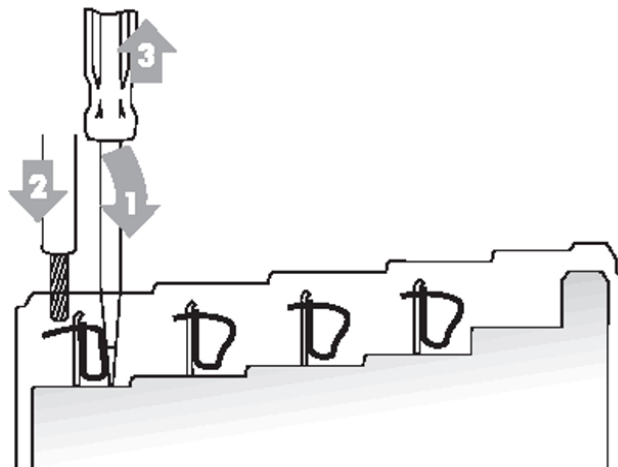

1. Insert a screwdriver or operating tool in the opening above the connection point.
2. The screwdriver blade holds the clamping spring open. Insert the conductor into the connection point.
3. Withdraw the screwdriver – the conductor is securely clamped.

9. PICS for *iTM* BACnet Client

Date: 1st April, 2012

Vendor Name: DAIKIN INDUSTRIES, Ltd.

Product Name: *intelligent Touch Manager (iTM)*

Product Model Number: DCM601A71

Application Software Version: 2.04.00

Firmware Revision: 000.001

BACnet Protocol Revision: 4

Product Description: This product provides the functions as a *BACnet* operator workstation to control and monitor the other *BACnet* server devices.

BACnet Standardized Device Profile (Annex L): *BACnet* Operator Workstation (B-OWS)

BACnet Interoperability Building Blocks Supported (Annex K):

	Supported BIBBs	BIBB Name	Support	
			STANDARD	OPTIONAL
Data Sharing	DS-RP-A	Data Sharing-ReadProperty-A	■	□
	DS-RP-B	Data Sharing-ReadProperty-B	■	□
	DS-RPM-A	Data Sharing-ReadPropertyMultiple-A	■	□
	DS-RPM-B	Data Sharing-ReadPropertyMultiple-B	□	■
	DS-WP-A	Data Sharing-WriteProperty-A	■	□
	DS-COVU-B	Data Sharing-COV-Unsolicited-B	□	■
Device Management	DM-DDB-A	Device Management-Dynamic Device Binding-A	■	□
	DM-DDB-B	Device Management-Dynamic Device Binding-B	■	□
	DM-DOB-B	Device Management-Dynamic Object Binding-B	■	□
	DM-TS-A	Device Management-Time Synchronization-A	■	□

Segmentation Capability:

- Able to transmit segmented messages Window Size _____
 Able to receive segmented messages Window Size _____

Standard Object Types Supported:

Object Type	Creatable	Delectable	Optional Object properties supported
Device Object	No	No	Max_Segment_Accepted, Local_Time, Local_Date, APDU_Segment_Timeout

9. PICS for *iTM BACnet Client*

The following objects can be monitored and controlled by the intelligent Touch Manager with *BACnet Client* software option based on object list available at a *BACnet* server.

Object Type	Creatable	Delectable	Optional Object properties supported
Analog Input	No	No	Present Value, Status_Flag
Analog Output	No	No	Present Value, Status_Flag
Analog Value	No	No	Present Value, Status_Flag
Binary Input	No	No	Present Value, Status_Flag
Binary Output	No	No	Present Value, Status_Flag
Binary Value	No	No	Present Value, Status_Flag
Multistate Input*	No	No	Present Value, Status_Flag
Multistate Output*	No	No	Present Value, Status_Flag
Multistate Value*	No	No	Present Value, Status_Flag

* Up to 10 states.

Data Link Layer Options: *BACnet* IP, (Annex J)

Device Address Binding:

Is static device binding supported? (This is currently necessary for two-way communication with MS/TP slaves and certain other devices.) Yes No

Networking Options:

Router, Clause 6 - List all routing configurations, e.g., ARCNET-Ethernet, Ethernet-MS/TP, etc.

Annex H, *BACnet* Tunneling Router over IP

BACnet/IP Broadcast Management Device (BBMD)

Does the BBMD support registrations by Foreign Devices? Yes No

Does the BBMD support network address translation? Yes No

Character Sets Supported:

Indicating support for multiple character sets does not imply that they can all be supported simultaneously.

ANSI X3.4

IBM™/Microsoft™ DBCS

ISO 8859-1

ISO 10646 (UCS-2)

ISO 10646 (UCS-4)

JIS X 0208

If this product is a communication gateway, describe the types of non-*BACnet* equipment/networks(s) that the gateway supports:

Not Applicable

10. Appendix-1

Appendix-1: List of Operation Data Indoor Units and Outdoor Units

A. Indoor Unit Operation Data

#	Point Name	Description
1	Discharge Air Temperature	Monitors and displays the discharge air temperature of the FXMQ_PB indoor unit. (displays zero all other units)
2	Liquid Pipe Temperature	Monitors and displays the liquid pipe temperature.
3	Gas Pipe Temperature	Monitors and displays the gas pipe temperature.
4	EEV Position	Monitors and displays the electronic expansion valve position.
5	Freeze Protection	Monitors if the freeze protection is active for FXFQ_T, FXUQ_P, or FXEQ_P indoor unit. (displays Off all other units)
6	Return Air Temperature	Monitor and displays the return air temperature.

B. General Outdoor Unit Operation Data

#	Point Name	Description
1	Communication Status	Monitors and displays the communication status
2	Operation Mode	Monitors and displays the operation mode (Cool, Heat, Fan or Heat & Cool)
3	Outdoor Unit Alarm Status	Monitors whether or not the outdoor unit is operating normally.
4	Defrost Mode	Monitors if the defrost mode is active.
5	Oil Return Mode	Monitors whether or not the outdoor unit is in oil return operation.
6	Electric Power	Monitors and displays the electric power. Calculated
7	Electric Current	Monitors and displays the electric current. Calculated
8	System Capacity Code	Monitors and displays the system capacity code.
9	Outdoor Air Temperature	Monitors and displays the outdoor air temperature.

C. Outdoor Unit Operation for each condenser module*

#	Point Name	Description
1	Condensing Pressure	Monitors and displays the condensing pressure
2	Evaporating Pressure	Monitors and displays the evaporating pressure
3	Condensing Temperature	Monitors and displays the condensing temperature
4	Evaporating Temperature	Monitors and displays the evaporating temperature
5	Inverter Compressor 1 Speed	Monitors and displays the speed of the inverter compressor1
6	Inverter Compressor 2 Speed	Monitors and displays the speed of the inverter compressor2
7	Fan Step	Monitors and displays the fan step
8	EV Position 1	Monitors and displays the position of the expansion valve1
9	EV position 2	Monitors and displays the position of the expansion valve2

10. Appendix-1

10	Hot Gas Temperature (Compressor 1)	Monitors and displays the hot gas temperature of the compressor1
11	Hot Gas Temperature (Compressor 2)	Monitors and displays the hot gas temperature of the compressor2
12	Liquid Pipe Temperature	Monitors and displays the liquid pipe temperature
13	Liquid Pipe Temperature (HX Upper)	Monitors and displays the liquid pipe temperature for the upper HX
14	Liquid Pipe Temperature (HX Lower)	Monitors and displays the liquid pipe temperature for the lower HX
15	Liquid Pipe Temperature (De-Icer)	Monitors and displays the liquid pipe temperature for the de-icer
16	Gas Pipe Temperature (HX Upper)	Monitors and displays the gas pipe temperature for the upper HX
17	Gas Pipe Temperature (HX Lower)	Monitors and displays the gas pipe temperature for the lower HX
18	Suction Temperature	Monitors and displays the suction temperature
19	Compressor Suction Temperature	Monitors and displays the compressor's suction temperature
20	Subcool Inlet Temperature	Monitors and displays the subcool inlet temperature
21	Subcool Outlet temperature	Monitors and displays the subcool outlet temperature
22	Subcool EV Position	Monitors and displays the subcool expansion valve position
23	Target Evaporator Temperature	Monitors and Displays the target evaporator temperature
24	Target Confessing Temperature	Monitor and Displays the target condensing temperature

*Points Availability varies based on the outdoor unit model type.

11. Appendix-2

Appendix-2: IT Network Requirements

The *intelligent Touch Manager* can be connected to the network to take advantages of the following features and options,

- » Remote Access
- » Email Alerts
- » *BACnet* Client option
- » *BACnet* Server/Gateway option
- » D-Net Monitoring

When connecting the *intelligent Touch Manager* to any network, the following IPv4 static IP address* settings are required and should be requested from building IT person.

1. IP Address
2. Subnet Mask
3. Default Gateway

In addition to the above settings, the additional settings may be required such as DNS address and a communication port.

If an IT person does not manage the building, all the network settings will have to be made by the startup technician. This will be a dedicated network and to connect a dedicated network to the internet there two options,

1. A dedicated public IP address from the internet provider.
2. 3G/4G modem with a cellular connection.

When using *BACnet* communication and the remote access features of the *iTM*, then IP NAT addressing or port forwarding may be required which should be set up by an IT person.

*The *intelligent Touch Manager* does not support DHCP or IPv6.

12. Glossary

Term	Definition
BACnet™	<i>BACnet</i> is a communications protocol for Building Automation and Control (BAC) networks that leverage the ASHRAE, ANSI, and ISO 16484-5 standard protocol
BTL	<i>BACnet</i> Testing Laboratories was established by <i>BACnet</i> International to support compliance testing and interoperability testing activities
<i>BACnet</i> Client	<i>BACnet</i> Client is a <i>BACnet</i> device that can control and monitor other <i>BACnet</i> servers in the building. Example: Building Management System (BMS)
<i>BACnet</i> Point	Refer to data points that are created by the programming in a <i>BACnet</i> Network, these typically calculated values such as setpoint, target values.
<i>BACnet</i> Server	<i>BACnet</i> server is a <i>BACnet</i> device that can be controlled or monitored by a Building Management System. Example: Rooftop Controller
BMS (Building Management System)	A system for building management activities such as HVAC control, lighting control, fire, energy, and security.
BTL Certification	BTL Certification provides certification of conformance for <i>BACnet</i> features implemented on a device.
D3-NET	A proprietary communication network developed by Daikin
Direct Digital Control (DDC)	Direct Digital Control is automation control of equipment or a process by an electronic controller based on its programming
DOAS	Dedicated Outside Air Unit or 100% outside air unit
DZK	Daikin Zoning Kit; A multi-zone variable volume solution for the <i>VRV</i>
Hardwire Point	Refers to any physically wired sensor or field devices
MS/TP	Master-slave - Token Passing, A communication type for the <i>BACnet</i> communication
POP Before SMTP	It is a type of authentication scheme used by a mail server
SMTP	Simple Mail Transfer Protocol (SMTP) is an Internet standard for electronic mail (email) transmission
SMTP=AUTH	It is a type of authentication scheme used by a mail server
<i>VRV</i>	Variable Refrigerant Volume
IP Address	IP is an identifier for a controller and a computer on a TCP/IP network. An IP address consists of four sets of numbers from 0 to 255, separated by three dots. Example: 172.20.15.44
DHCP	Stands for "Dynamic Host Configuration Protocol." DHCP is a protocol that automatically assigns a unique IP address to each device that connects to a network. With DHCP, there is no need to assign IP addresses to new devices manually. Not supported by <i>intelligent Touch Manager</i> .
Static IP Address	A static Internet Protocol (IP) address (static IP address) is a permanent number assigned to a computer or controller by a Network Administrator. A static IP address is required for the <i>intelligent Touch Manager</i>
NAT	Network Address Translation (NAT). NAT is a method of remapping an IP address onto another IP address. This method is used when a local network IP address is remapped to a more global IP address to provide access.



WARNING

- » Only qualified personnel must complete the installation.
- » Consult your Daikin dealer regarding relocation and reinstallation of the remote controller. Improper installation may result in electric shock or fire.
- » Electrical work must be performed in accordance with relevant local and national regulations, and with the instructions in this installation manual. Improper installation may cause electric shock or fire.
- » Only use specified accessories and parts for installation. Failure to use specified parts may result in electric shock, fire, or controller damage.
- » Do not disassemble, reconstruct, or repair. Electric shock or fire may occur.
- » Only use specified wiring and verify all wiring is secured. Assure no external forces act on the terminal connections or wires. Improper connections or installation may result in electric shock or fire.
- » Confirm power to the unit is OFF before touching electrical components.

About Daikin:

DAIKIN Daikin Industries, Ltd. (DIL) is a global Fortune 1000 company which celebrated its 95th anniversary in May 2019. The company is recognized as one of the largest HVAC (Heating, Ventilation, Air Conditioning) manufacturers in the world. DIL is primarily engaged in developing indoor comfort systems and refrigeration products for residential, commercial and industrial applications. Its consistent success is derived, in part, from a focus on innovative, energy-efficient and premium quality indoor climate and comfort management solutions.

ADDITIONAL INFORMATION

Before purchasing this appliance, read important information about its estimated annual energy consumption, yearly operating cost, or energy efficiency rating that is available from your retailer.

Visit www.daikinac.com or www.daikincity.com to learn more.



Our continuing commitment to quality products may mean a change in specifications without notice.

© 2020 **DAIKIN NORTH AMERICA LLC** · Houston, Texas · USA · www.daikincomfort.com or www.daikinac.com

CAG-ITM_BMS 07-20