

MAKING MODERN LIVING POSSIBLE



Danfoss VLT Drives VLT® Product Catalogue



50%

Energy saving

Speed control of fans and pumps can in many cases lead to significant energy savings.

www.danfoss.com/drives

VLT[®]
THE REAL DRIVE





Contents

PAGE 6



VLT® AutomationDrive

A single drive concept that covers the entire spectrum of drives applications – a major benefit in commissioning, operating and maintaining the equipment. VLT® AutomationDrive comes in a standard version (FC 301) and an advanced high dynamic version (FC 302) with additional functionalities, asynchronous and PM motor control.

PAGE 10



VLT® HVAC Drive

The VLT® HVAC Drive is a dedicated, globally supported drive that combines flexibility and efficiency in a package designed to minimize total system and lifecycle costs in HVAC applications. Designed to provide the highest efficiency solution with both asynchronous and permanent magnet motors from all major suppliers, the VLT® HVAC drive is the leading drive for heating, ventilation and air conditioning systems.

PAGE 13



VLT® Refrigeration Drive

Specially designed for the needs of refrigeration applications covering compressors, evaporators, condensers, pumps and cooling towers. Efficiently runs compressors, fans and pumps. Setup of the drive is made easy by the built-in setup guide, that helps the installer program the drive effectively & efficiently thus improving people productivity and processes performance.

PAGE 16



VLT® AQUA Drive

The perfect match for pumps and blowers in modern water and wastewater systems, offering advanced application protective features. Available with cascade control of up to 8 pumps in fixed speed mode or master/follower mode.

PAGE 20



VLT® Lift Drive

Ideal solution for rope and hydraulic elevators. The drive is designed to meet the comfort requirements. High efficiency and motor independent-concept help us differentiate from competitors.

PAGE 22



VLT® 2800 Series

A multi purpose drive offering a perfect match between price and performance for industrial applications up to 18,5 kW.

PAGE 24



VLT® Micro Drive

A compact general purpose drive for AC motors up to 22 kW. It performs perfectly even in complex application set-ups and optimises energy efficiency and operation.

PAGE 26



VLT® Decentral Drive FCD 302

The new generation of decentral drives based on the VLT® AutomationDrive FC 302 platform. It combines the key features of both products in a completely re-designed enclosure, made for best fit on direct machine mounting.

PAGE 28



VLT® Decentral Drive FCD 300

A complete frequency converter designed for decentral mounting. It can be mounted on the machine/wall – close to the motor. The decentral design eliminates the need for space-consuming control cabinets and the need for long screened motor cables is significantly reduced.

PAGE 30



VLT® DriveMotor FCP 106

With a wide range of standard integrated pump and fan features, the VLT® DriveMotor FCP 106 can provide efficient control of motors in the 0.55 – 7.5 kW range. By mounting the drive directly on the motor, owners are free to choose their own motor manufacturer and design the optimal system for their application.

PAGE 32



VLT® DriveMotor FCM 106

With a wide range of standard, integrated pump and fan features, the VLT® DriveMotor FCM 106 is a highly dedicated, space saving motor and control solution in the 0.55-7.5 kW range. The drive is delivered from the factory attached to either a standard induction motor or a size optimized permanent magnet motor.

PAGE 34



VLT® DriveMotor FCM 300

Integrated drive-motor solution which combines a VLT® frequency converter and a high standard quality induction motor in a single product. The frequency converter is attached in place of the motor terminal box and it is no higher than the standard terminal box – nor wider or longer than the motor.

PAGE 36



VLT® OneGearDrive®

A highly efficient permanent-magnet three-phase synchronous motor coupled to an optimised bevel gear box. As part of the Danfoss VLT® FlexConcept® the VLT® OneGearDrive® is an energy-efficient drive system that helps to optimise plant productivity and reduce energy costs.

PAGE 38



VLT® Integrated Servo Drive System ISD 410

A high performance Integrated Servo Drive system based on PM motor technology. The motion control is integrated in the drive. The communication bus is CAN. It is a system for applications with a variable number of axis and it allows flexible machine structure within food & beverage and packaging.



VLT® Soft Starter MCD 500

A total motor-starting solution with advanced start, stop and protection features, Adaptive Acceleration Control, inside delta connection, 4 line graphical display and multiple programming setup menus.



VLT® Compact Starter MCD 200

A compact and cost effective soft starter range for applications where direct-on-line starting is undesirable. MCD 200 is, because of its size and functionality, a good alternative to other reduced voltage starting methods such as star/delta starters.



VLT® Soft Start Controller MCD 100

A cost effective and extremely compact soft starter for AC motors from 1.1 – 11 kW. Due to a unique semiconductor design it is a true “fit and forget” product.



VLT® Low Harmonic Drive

Meets the toughest harmonic requirements under all load/grid conditions. The Danfoss VLT® Low harmonic drive is the first solution combining an active filter and a drive in one package. The VLT® Low harmonic drive continuously regulates harmonic suppression according to the load and grid conditions without affecting the connected motor.



12-pulse VLT® drive

A robust and cost effective harmonic solution for the higher power range. The Danfoss 12-pulse VLT® drive offers reduced harmonics for demanding industry applications above 250 kW. The 12-pulse VLT® drive is a high efficiency variable frequency converter which is built to the same modular design as the popular 6-pulse VLT® drives.



VLT® Advanced Active Filter AAF 006

A flexible and adaptable solution for central or decentral harmonic mitigation. Danfoss Advanced Active Filters can compensate for individual VLT® drives as a compact integrated solution or can be installed as a compact stand-alone solution at a point of common coupling, compensating for multiple loads simultaneously. Danfoss Active Filters can operate at medium voltage level by means of a step-down transformer.



VLT® Advanced Harmonic Filter AHF 005/010

The Danfoss Advanced Harmonic Filters have been specially designed to match the Danfoss frequency converters. The solution is available in two variants, AHF 005 and AHF 010, connected in front of a Danfoss frequency converter, the harmonic current distortion generated back to the mains is reduced to 5% and 10% Total Harmonic Current Distortion at full load.



VLT® Common Mode Filters

Common mode filters are placed between the frequency converter and the motor. They are nano-crystalline cores that mitigate high frequency noise in the motor cable (shielded or unshielded) and reduce bearing currents in the motor.



VLT® Sine-Wave Filters

Sine-Wave filters are placed between the frequency converter and the motor. They are differential-mode low-pass filters that suppress the switching frequency component from the frequency converter and smooth out the phase-to-phase output voltage of the frequency converter to make it sinusoidal. This reduces the motor insulation stress, bearing currents and eliminates the switching acoustic noise from the motor.



VLT® dU/dt Filters

dU/dt filters are placed between the frequency converter and the motor. They are differential-mode low-pass filters that reduce motor terminal phase-to-phase peak voltage spikes and reduce the rise time to a level that lowers the stress on the insulation of motor windings. dU/dt filters are smaller, weigh less and have a lower price compared to Sine-Wave filters.



VLT® Motion Control Tool MCT 10

The VLT® Motion Control Tool MCT 10 is the perfect tool to handle all drive-related data. The tool is useful in all phases of your project: programming, commissioning, daily use and even useful for service and maintenance purposes. During commissioning a project can be prepared offline in advance and uploaded when the system is online.



VLT® Motion Control Tool MCT 31

With VLT® Motion Control Tool MCT 31, you can determine whether harmonics will be an issue in your installation as a consequence of nonlinear load. MCT 31 estimates the benefits of adding various harmonic mitigation solutions from the Danfoss product portfolio and calculates system harmonic distortion.



VLT® Energy Box

With the VLT® Energy Box Software you can early in the project estimate the energy savings. Later you can easily compare your estimations with the actual energy savings and carbon footprint reduction using the trend and energy data stored in your drive.



VLT® Service – Your way

DrivePro™ is an efficient productivity programme tailored to meet your specific needs. All the necessary VLT® Service facilities are at your disposal, which will minimize downtime and increase productivity at your factory.

VLT® AutomationDrive



The premier, globally supported drive concept for exceptional control of motor driven applications.

Designed for variable speed control of all asynchronous motors and permanent magnet motors, on any industrial machine or production line, a VLT® AutomationDrive helps its owner save energy, increase flexibility, and optimize processes.

Flexible and expandable

Built on a flexible, modular design concept the AutomationDrive is packed with standard, industry features out of the box. These can be expanded with plug-and-play options with additional features, positioning control, fieldbuses, safety functions such as STO, SS1, SLS, SMS and SSM, motor protection and more.

Robust and safe

VLT AutomationDrives are proven performers in all industrial environments and grid voltages, including 690V. Enclosures are available up to IP 66 (depending on model), and integrated DC chokes and RFI filters in all models protect installations by minimizing harmonic distortion and electromagnetic interferences. All drives are fully tested at the factory before they are shipped.

Feature	Benefit
Reliable	Maximum uptime
Ambient temperature 50° C without derating	Less need for cooling or oversizing
Available in IP 00, 20, 21, 54, 55 and 66 enclosures	Enclosures for all environments
Resistant to wear and tear	Low lifetime cost
Back-channel cooling for frame D, E and F	Prolonged lifetime of electronics
User-friendly	Saves commissioning and operating cost
Plug-and-Play technology	Easy upgrade and changeover
Awarded control panel	User-friendly
Intuitive VLT® interface	Saves time
Pluggable cage clamp connectors	Easy connection
Exchangeable languages	User-friendly
Intelligent	
Intelligent warning systems	Warning before controlled stop
Smart Logic Control	Reduces need for PLC capacity
Advanced plug-in features	Easy commissioning
Safe stop	Safety cat. 3, PL d (ISO 13849-1), Stop cat. 0 (EN 60204-1)
STO: Safe Torque Off (IEC 61800-5-2)	SIL 2 (IEC 61508) SIL CL 2 (IEC 62061)
Intelligent heat management	Intelligent heat management

Easy to set up and operate via the user-friendly graphical control panel, a VLT AutomationDrive only requires little maintenance once in operation. The result is a market leading control solution that provides a fast return on investment and a highly competitive cost of ownership.

Power range

3 x 200 – 240 V.....	0.25 – 37 kW
3 x 380 – 480/500 V.....	0.37 – 800 kW
3 x 525 – 600 V.....	0.75 kW – 75 kW
3 x 525 – 690 V.....	1.1 kW – 1.2 MW
Normal overload.....	1.5 kW – 1.4 MW

Fieldbus options

- VLT® PROFIBUS DP MCA 101
- VLT® DeviceNet MCA 104
- VLT® CanOpen MCA 105
- VLT® Profibus Converter MCA 113
- VLT® Profibus Converter MCA 114
- VLT® PROFINET MCA 120
- VLT® Ethernet/IP MCA 121
- VLT® Modbus TCP MCA 122
- VLT® POWERLINK MCA 123
- VLT® EtherCAT MCA 124
- VLT® DeviceNet Converter MCA 194

I/O and feedback options

- VLT® General Purpose I/O MCB 101
- VLT® Encoder Input MCB 102
- VLT® Resolver Input MCB 103
- VLT® Relay Card MCB 105
- VLT® 24 V External Supply MCB 107
- VLT® Extended Relay Card MCB 113
- VLT® Sensor Input MCB 114

Safety options

- VLT® Safe PLC I/O MCB 108
- VLT® PTC Thermistor Card MCB 112
- VLT® Safe Option MCB 140 Series
- VLT® Safe Option MCB 150 Serie

Motion Control Options

- VLT® Motion Control Option MCO 305
- VLT® Synchronizing Controller MCO 350
- VLT® Position Controller MCO 351
- VLT® Center Winder MCO 352

Power options

- VLT® Brake resistors MCE 101
- VLT® Sine-Wave Filters MCC 101
- VLT® dU/dt Filters MCC 102
- VLT® Common Mode Filter MCC 105
- VLT® Advanced Harmonic Filters AHF 005/010

Other accessories

- IP 21/NEMA 1 Kit (convert IP 20 to IP 21)
- PROFIBUS adapter
- Sub-D9 Connector
- Decoupling plate for fieldbus cables
- USB connection cable to PC
- Panel Through option
- LCP panel mounting kit
- Mounting brackets
- Mains disconnect option
- USB Extension
- Interbus gateway MCA 110
- Option Adapter
- RCMB20/RCMB35 Leakage Current Monitor Module

Specifications

Mains supply (L1, L2, L3)	
Supply voltage	200 – 240 V ±10% FC 301: 380 – 480 V ±10% FC 302: 380 – 500 V ±10%, 525 – 600 V ±10% 525 – 690 V ±10%
Supply frequency	50/60 Hz
True Power Factor (λ)	0.92 nominal at rated load
Displacement Power Factor ($\cos \phi$) near unity	(> 0.98)
Switching on input supply L1, L2, L3	Maximum 2 times/min.
Output data (U, V, W)	
Output voltage	0 – 100% of supply voltage FC 301: 0.2 – 590 Hz (0.25 – 75 kW) FC 302: 0 – 590 Hz (0.25 – 75 kW) 0 – 590 Hz (90 – 1200 kW) 0 – 300 Hz (Flux mode)
Output frequency	
Switching on output	Unlimited
Ramp times	1–3600 sec.
<i>Note: 160% current can be provided for 1 minute. Higher overload rating is achieved by oversizing the drive.</i>	
Digital inputs	
Programmable digital inputs	FC 301: 4 (5) / FC 302: 4 (6)
Logic	PNP or NPN
Voltage level	0–24 VDC
<i>Note: One/two digital inputs can be programmed as digital output for FC 301/FC 302.</i>	
Analogue input	
Analogue inputs	2
Modes	Voltage or current
Voltage level	FC 301: 0 to +10 V FC 302: -10 to +10 V (scaleable)
Current level	0/4 to 20 mA (scaleable)
Pulse/encoder inputs	
Programmable pulse/encoder inputs	FC 301: 1 / FC 302: 2
Voltage level	0 – 24 V DC (PNP positive logic)
Digital output*	
Programmable digital/pulse outputs	FC 301: 1 / FC 302: 2
Voltage level at digital/frequency output	0 – 24 V
Analogue output*	
Programmable analogue outputs	1
Current range	0/4–20 mA
Relay outputs*	
Programmable relay outputs	FC 301: 1 / FC 302: 2
Cable lengths	
Max. motor cable lengths	FC 301: 50 m / FC 302: 150 m (screened/armoured) FC 301: 75 m / FC 302: 300 m (unscreened/unarmoured)

*More analogue and digital inputs/outputs can be added with options.

Brake chopper (IGBT) option

Limits the load on the intermediate circuit in the case the motor acts as a generator.

High power options

- Emergency stop with Safety Relay
- Safety Stop with Safety Relay
- RFI Filters
- NAMUR terminals
- Residual Current Device
- Insulation Resistance Monitor
- Mains shielding
- Regen terminals

Please see the VLT® High Power Drive Selection Guide for the complete range of options.

Current and power ratings

FC 300	kW		T2 200 – 240 V						T4/T5 380 – 480/500 V													
			Amp.		IP 20	IP 21	IP 55	IP 66	Amp. HO		Amp. NO		IP 00	IP 20	IP 21	IP 54	IP 55	IP 66				
	HO	NO	HO	NO					≤440 V	>440 V	≤440 V	>440 V										
PK25	0.25		1.8		A1*/A2	A2	A4/A5	A4/A5														
PK37	0.37		2.4						1.3	1.2	1.3	1.2										
PK55	0.55		3.5						1.8	1.6	1.8	1.6										
PK75	0.75		4.6						2.4	2.1	2.4	2.1										
P1K1	1.1		6.6						3	2.7	3	2.7										
P1K5	1.5		7.5						4.1	3.4	4.1	3.4										
P2K2	2.2		10.6						5.6	4.8	5.6	4.8										
P3K0	3		12.5						7.2	6.3	7.2	6.3										
P3K7	3.7		16.7																			
P4K0	4.0												10	8.2	10	8.2						
P5K5	5.5	7.5	24.2	30.8	B3	B1	B1	B1	13	11	13	11										
P7K5	7.5	11	30.8	46.2					16	14.5	16	14.5										
P11K	11	15	46.2	59.4					24	21	32	27										
P15K	15	18	59.4	74.8					32	27	37.5	34										
P18K	18.5	22	74.8	88					37.5	34	44	40										
P22K	22	30	88	115					44	40	61	52										
P30K	30	37	115	143					61	52	73	65										
P37K	37	45	143	170					73	65	90	80										
P45K	45	55							90	80	106	105										
P55K	55	75							106	105	147	130										
P75K	75	90			147	130	177	160														
N55K																						
N75K																						
N90K	90	110							177	160	212	190										
N110	110	132							212	190	260	240										
N132	132	160							260	240	315	302										
N160	160	200							315	302	395	361										
N200	200	250							395	361	480	443										
N250	250	315							480	443	588	535										
N315	315																					
P250	250	315							480	443	600	540										
P315	315	400							600	540	658	590										
P355	355	450							658	590	745	678										
P400	400	500							695	678	800	730										
P450	450	500							800	730	880	780										
P500	500	560							880	780	990	890										
P560	560	630							990	890	1120	1050										
P630	630	710							1120	1050	1260	1160										
P710	710	800							1260	1160	1460	1380										
P800	800	1000							1460	1380	1720	1530										
P900	900	1000																				
P1M0	1000	1200																				
P1M2	1200	1400																				
P1M4	Consult factory																					
P1M6	Consult factory																					

* For selection of A1 see enclosure types in the code position 4 (FC 301 only)

IP 00/Chassis	IP 20/Chassis	IP 21/Type 1	With upgrade kit – available in US only	IP 54/Type 12	IP 55/Type 12	IP 66/NEMA 4X
---------------	---------------	--------------	---	---------------	---------------	---------------

FC 300	kW		T6 525 – 600 V								T7 525 – 690 V										
			Amp. HO		Amp. NO		IP 20	IP 21	IP 55	IP 66	Amp. HO		Amp. NO		IP 00	IP 20	IP 21	IP 54	IP 55	IP 66	
	HO	NO	≤550 V	>550 V	≤550 V	>550 V					550 V	690 V	550 V	690 V							
PK25	0.25																				
PK37	0.37																				
PK55	0.55																				
PK75	0.75				1.8	1.7															
P1K1	1.1				2.6	2.4					2.1	1.6									
P1K5	1.5				2.9	2.7	A3	A3	A5	A5	2.7	2.2			A3	A3					
P2K2	2.2				4.1	3.9					3.9	3.2									
P3K0	3				5.2	4.9					4.9	4.5									
P3K7	3.7																				
P4K0	4.0				6.4	6.1					6.1	5.5									
P5K5	5.5	7.5			9.5	9	A3	A3	A5	A5	9	7.5			A3	A3					
P7K5	7.5	11			11.5	11					11	10	14	13							
P11K	11	15	19	18	23	22	B3	B1	B1	B1	14	13	19	18							
P15K	15	18	23	22	28	27					19	18	23	22							
P18K	18.5	22	28	27	36	34					23	22	28	27							
P22K	22	30	36	34	43	41	B4	B2	B2	B2	28	27	36	34							
P30K	30	37	43	41	54	52					36	34	43	41							
P37K	37	45	54	52	65	62	C3	C1	C1	C1	43	41	54	52							
P45K	45	55	65	62	87	83					54	52	65	62							
P55K	55	75	87	83	105	100	C4	C2	C2	C2	65	62	87	83							
P75K	75	90	105	100	137	131					87	83	105	100							
N55K	55	75									76	73	90	86							
N75K	75	90									90	86	113	108							
N90K	90	110									113	108	137	131							
N110	110	132									137	131	162	155							
N132	132	160									162	155	201	192							
N160	160	200									201	192	253	242							
N200	200	250									253	242	303	290							
N250	250	315									303	290	360	344							
N315	315	400									360	344	418	400							
P250	250	315																			
P315	315	400																			
P355	355	450									395	380	470	450	E2	E1	E1				
P400	400	500									429	410	523	500							
P450	450	500																			
P500	500	560									523	500	596	570	E2	E1	E1				
P560	560	630									596	570	630	630							
P630	630	710									659	630	763	730							
P710	710	800									763	730	899	850							
P800	800	900									889	850	988	945							
P900	900	1000									988	945	1108	1060							
P1M0	1000	1200									1108	1060	1317	1260							
P1M2	1200	1400									1317	1260	1479	1415							

Dimensions [mm]

	A1	A2	A3	A4	A5	B1	B2	B3	B4	C1	C2	C3	C4	D1h	D2h	D3h	D4h	D5h	D6h	D7h	D8h	E1	E2	F1	F2	F3	F4
H	200	268	390	420	480	650	399	520	680	770	550	660	901	1107	909	1122	1324	1665	1978	2284	2000	1547	2280	2280	2280	2280	2280
W	75	90	130	200		242		165	230	308	370	308	370	325	420	250	350	325	420	600	585	1400	1804	1997	2401		
D	207	205	175	200	260	249	242	310	335			333		378		375	381	384	402	494	498	607	607	607	607	607	607
H+		375				475	670					755	950														
W+	90	130				165	255					329	391														

Note: H and W dimensions are with back-plate. H+ and W+ are with IP upgrade kit. D dimensions are without option. A or B for A2 and A3.

VLT® HVAC Drive



The VLT® HVAC Drive series is available in a wide power range designed for all HVAC applications. An advanced drive built on HVAC dedication.

The VLT® HVAC Drive is a full-featured, HVAC dedicated drive with built-in intelligence. Every VLT® HVAC Drive is based on 25 years of experience and innovation.

The VLT® HVAC Drive has a vast number of functions developed to meet the diverse needs of the HVAC business. Easy to use, all models follow the same basic design and operating principle. Once you know one, you know them all.

It is the perfect match for pumps, fans and compressors in modern buildings that are fitted with increasingly sophisticated solutions.

Product range

3 x 200 – 240 V.....	1.1 – 45 kW
3 x 380 – 480 V.....	1.1 – 1000 kW
3 x 525 – 600 V.....	1.1 – 90 kW
3 x 525 – 690 V.....	1.1 – 1400 kW

With 110% over load torque

Available enclosure ratings

IP 00.....	335 – 630 kW
IP 20.....	1.1 – 400 kW
IP 21 (Type 1).....	1.1 – 1400 kW
IP 54 (Type 12).....	75 – 1400 kW
IP 55 (Type 12).....	1.1 – 90 kW
IP 66 (NEMA 4X indoor).....	1.1 – 90 kW

Optional coating providing extra protection for aggressive environments.

Feature	Benefit
All built-in – low investment	
Modular product concept and a wide range of options	Low initial investment – max. flexibility, later upgrade possible
Dedicated HVAC I/O functionality for temperature sensors etc.	External conversion saved
Decentral I/O control via serial communication	Reduced wiring costs, and external controller I/O saved
Wide range of HVAC protocols for BMS controller connectivity	Less extra gateway solutions needed
4 x auto tuned PID's	No external PID controller needed
Smart Logic Controller	Often makes PLC unnecessary
Real Time Clock	Enables daily and weekly settings
Integrated fan, pump and compressor functionality i.e.	Saves external control and conversion equipment
Fire Override Mode, Dry run Detection Constant Torque etc.	Protects equipment and saves energy
Back-channel cooling for frame D, E and F frame	Prolonged lifetime of electronics
Save energy – less operation cost	
Automatic Energy Optimizer function, advanced version	Saves 5 – 15% energy
Advanced energy monitoring	Overview on energy consumption
Energy saving functions i.e. flow compensation, sleep mode etc.	Saves energy
Unequaled robustness – maximum uptime	
Robust single enclosure	Maintenance-free
Unique cooling concept with no ambient air flow over electronics	Problem-free operation in harsh environments
Max ambient temp. 50° C without derating	No external cooling or oversize necessary
User-friendly – save commissioning and operating cost	
Smart start	Quick and precise start-up
Awarded graphical display, 27 languages	Effective commissioning and operation
USB plug and play connection	Easy to use PC software tools
Global HVAC support organisation	Local service – globally
Built-in DC coils and RFI filters – no EMC concerns	
Integrated DC link harmonic filters	Small power cables. Meets EN 61000-3-12
Integrated EMC filters	Meets EN 55011 Class B, A1 or A2 and IEC61800-3 Category C1, C2 and C3

Application options

A wide range of integrated HVAC options can be fitted in the drive:

VLT® General Purpose I/O MCB 101

3 digital inputs, 2 digital outputs, 1 analogue current output, 2 analogue voltage inputs.

VLT® Relay Card MCB 105

Adds 3 relay outputs

VLT® Analog I/O MCB 109

3 PT1000/Ni1000 inputs, 3 analogue voltage outputs and back-up power for Real-Time Clock.

VLT® 24 V External Supply MCB 107

24 V DC external supply can be connected to supply, control and option cards.

Sensor input card

Sensor input card for motor protection with 2 or 3 PT100 or PT1000 inputs (VLT® Sensor Input MCB 114).

Brake chopper (IGBT) option

Connected to an external brake resistor, the built-in brake chopper limits the load on the intermediate circuit in the case the motor acts as a generator.

Power options

A wide range of external power options are available for VLT® HVAC Drive in critical networks or applications:

- **Advanced Harmonic Filters:** For critical demands on harmonic distortion
- **dU/dt filters:** For special demands on motor isolation protection
- **Sine-Wave filters**

HVAC PC software tools

- **VLT® Motion Control Tool MCT 10:** Ideal for commissioning and servicing the drive
- **VLT® Energy Box:** Comprehensive energy analysis tool. Energy consumption with and w/o drive can be calculated (drive payback time). Online function for accessing drives energy log.
- **VLT® Motion Control Tool MCT 31:** Harmonics calculations tool

Specifications

Mains supply (L1, L2, L3)	
Supply voltage	200–240 V ±10% 380–480 V ±10% 525–600 V ±10% 525–690 V ±10%
Supply frequency	50/60 Hz
Displacement Power Factor (cos φ) near unity	(> 0.98)
Switching on input supply L1, L2, L3	1–2 times/min.
Output data (U, V, W)	
Output voltage	0–100% of supply voltage
Switching on output	Unlimited
Ramp times	1–3600 sec.
Output frequency	0–590 Hz
Digital inputs	
Programmable digital inputs	6*
Logic	PNP or NPN
Voltage level	0–24 VDC
* 2 can be used as digital outputs	
Pulse inputs	
Programmable pulse inputs	2*
Voltage level	0–24 VDC (PNP positive logic)
Pulse input accuracy	(0.1–110 kHz)
* Utilize some of the digital inputs	
Analogue input	
Analogue inputs	2
Modes	Voltage or current
Voltage level	0 V to +10 V (scaleable)
Current level	0/4 to 20 mA (scaleable)
Analogue output	
Programmable analogue outputs	1
Current range at analogue output	0/4–20 mA
Relay outputs	
Programmable relay outputs	2 (240 VAC, 2 A and 400 VAC, 2 A)
Fieldbus communication	
Standard built-in: FC Protocol N2 Metasys Modbus RTU BACnet embedded	Optional: VLT® LonWorks MCA 108 VLT® BACnet MCA 109 VLT® DeviceNet MCA 104 VLT® PROFIBUS DP MCA 101 VLT® PROFINET MCA 120 VLT® EtherNet/IP MCA 121 VLT® Modbus TCP MCA 122

High power options

- IEC Emergency stop with Safety Relay
- Safety Stop with Safety Relay
- RFI Filters
- NAMUR terminals
- RCD
- IRM
- Mains shielding
- Regen terminals

Please see the VLT® High Power Drive Selection Guide for the complete range of options.

Current and power ratings

FC 102	kW	T2 200 – 240 V				T4 380 – 480 V						T6 525 – 600 V					T7 525 – 690 V							
		Amp.	IP 20	IP 21	IP 55	IP 66	Amp.		IP 00	IP 20	IP 21	IP 54	IP 55	IP 66	Amp.		IP 20	IP 21	IP 54	IP 55	IP 66			
							≤440 V	>440 V							≤550 V	>550 V						550 V	690 V	
P1K1	1.1	6.6					3	2.7						2.6	2.4						2.1	1.6		
P1K5	1.5	7.5	A2	A2	A4/A5	A4/A5	4.1	3.4						2.9	2.7						2.7	2.2		
P2K2	2.2	10.6					5.6	4.8	A2	A2				4.1	3.9	A3	A3	A5	A5		3.9	3.2	A3	
P3K0	3	12.5	A3	A3	A5	A5	7.2	6.3						5.2	4.9						4.9	4.5		
P3K7	3.7	16.7																						
P4K0	4.0						10	8.2	A2	A2				6.4	6.1						6.1	5.5		
P5K5	5.5	24.2					13	11	A3	A3				9.5	9	A3	A3	A5	A5		9	7.5	A3	
P7K5	7.5	30.8	B3	B1	B1	B1	16	14.5						11.5	11						11	10		
P11K	11	46.2					24	21						19	18						14	13		
P15K	15	59.4					32	27	B3	B1				23	22	B3	B1	B1	B1		19	18		
P18K	18	74.8	B4	B2	B2	B2	37.5	34						28	27						23	22		B2
P22K	22	88					44	40						36	34						28	27		B2
P30K	30	115	C3	C1	C1	C1	61	52	B4	B2				43	41	B4	B2	B2	B2		36	34		
P37K	37	143					73	65						54	52						43	41		
P45K	45	170	C4	C2	C2	C2	90	80						65	62						54	52	C3	C2
P55K	55						106	105	C3	C1				87	83	C3	C1	C1	C1		65	62		C2
P75K	75						147	130						105	100						87	83		
P90K	90						177	160	C4	C2				137	131	C4	C2	C2	C2		105	100		
N75K*	75																				90	86		
N90K*	90																				113	108		
N110	110						212	190													137	131	D3h	D1h/D5h/D6h
N132	132						260	240	D3h	D5h/D6h	D5h/D6h										162	155		D1h/D5h/D6h
N160	160						315	302													201	192		
N200	200						395	361													253	242		
N250	250						480	443	D4h	D2h/D7h/D8h	D2h/D7h/D8h									303	290			
N315	315						588	535													360	344	D4h	D2h/D7h/D8h
N400	400																				418	400		
P355	355						658	590																
P400	400						745	678	E2	E1	E1													
P450	450						800	730													470	450	E2	E1
P500	500						880	780													523	500		E1
P560	560						990	890													596	570		E1
P630	630						1120	1050													630	630		
P710	710						1260	1160													763	730		
P800	800						1460	1380													889	850		F1/F3
P900	900																				988	945		F1/F3
P1M0	1000						1720	1530													1108	1060		F2/F4
P1M2	1200																				1317	1260		F2/F4
P1M4	1400																				1479	1415		F2/F4

* @ 690 V

IP 00/Chassis	IP 20/Chassis	IP 21/Type 1	With upgrade kit – available in US only	IP 54/Type 12	IP 55/Type 12	IP 66/NEMA 4X
---------------	---------------	--------------	---	---------------	---------------	---------------

Dimensions [mm]

	A2	A3	A4	A5	B1	B2	B3	B4	C1	C2	C3	C4	D1h	D2h	D3h	D4h	D5h	D6h	D7h	D8h	E1	E2	F1	F2	F3	F4
H	268		390	420	480	650	399	520	680	770	550	660	901	1107	909	1122	1324	1665	1978	2284	2000	1547	2280	2280	2280	2280
W	90	130	200		242		165	230	308	370	308	370	325	420	250	350		325		420	600	585	1400	1804	1997	2401
D	205		175	200	260		249	242	310	335		333									494	498	607	607	607	607
H+	375						475	670				755	950													
W+	90	130					165	255				329	391													

Note: H and W dimensions are with back-plate. H+ and W+ are with IP upgrade kit. D dimensions are without option. A or B for A2 and A3.

VLT® Refrigeration Drive



Dedicated

to refrigeration application

Specially designed for the needs of refrigeration applications, but also capable of running pump and fan applications.

Regardless if you want to operate compressors, pumps or fans, the VLT® Refrigeration Drive FC 103 provides you the possibility to save energy and extend the lifetime of the components.

Speed control provides many benefits in all motor driven parts of refrigeration applications. The VLT® Refrigeration Drive moves the user in the position to profit from this in a very simple way by saving energy and prolonging lifetime of essential equipment.

One drive for all

The VLT® Refrigeration Drive FC 103 covers a power range between 1.1-315 kW. Available in a variety of protection classes the drive suits the needs of pump, fan and compressor applications. Every application and power size can be operated and programmed with the same common user interface.

Easy commissioning

The VLT Refrigeration Drive FC 103 offers a setup Wizard, using common refrigeration terms rather than computer language, making installation quick and easy for service technicians and installers. The wizard menu also supports the commissioning engineers if they encounter any problems. The menu will help the engineer troubleshoot and offer solutions to get the drive up and running again if there is a problem.

Feature	Benefit
Robust single enclosure	Maintenance free
Protection classes IP 20/21/55/66	Fits every application
Coated electronics (class 3C2 or 3C3)	Withstands challenging environments
Max. ambient temp. 50° C without derating	No external cooling or oversize necessary
Software features	Benefits
Sleep mode	Optimum system efficiency
Thermostat/Pressostat function	System protection
Fieldbus (AKD LON, Modbus RTU...)	Open for all kind of controllers
Velocity-to-flow conversion	Saves costs
Day/Night Control	Reduces wear and energy consumption
Advanced energy monitoring	Overview of energy consumption
Pressure to temperature conversion	Saves costs
Compressor features	Benefits
High starting torque	Operates all types of compressor
PO optimization	Optimum system efficiency
Injection on/off	Improves refrigeration processes
Discharge temperature monitor	Protects the compressor
Pack controller	Saves energy and reduce maintenance
Neutral zone controller	Handling of unsymmetrical zones
Pump features	Benefits
Pump cascade controller	Saves energy and reduce maintenance
Dry pump protection and end of curve	Protects the pump
Flow compensation	Saves energy
Fan features	Benefits
Broken belt detection	Protects the system
Operate induction motors in parallel	Reduces investment cost
Automatic Energy Optimizer AEO function	Saves energy
No EMC concerns	Benefits
Integrated DC link harmonic filters	Low harmonic load on mains
Integrated EMC filters	No external filters required

VLT® Refrigeration Drive – continued

Product range

3 x 200 – 240 V 1.1 – 45 kW
 3 x 380 – 480 V 1.1 – 315 kW
 3 x 525 – 600 V 1.1 – 90 kW
 With 110% overload torque

Available enclosure ratings

IP 20 (NEMA 1) 1.1 – 315 kW
 IP 21 (NEMA 1) 1.1 – 315 kW
 IP 54 (NEMA 12) 110 – 315 kW
 IP 55 (NEMA 12) 1.1 – 90 kW
 IP 66 (NEMA 4X) 1.1 – 90 kW

Standard coating providing extra protection for aggressive environments.

Options

A wide range of VLT® Refrigeration Drive FC 103 options are available mounted and tested from the factory or as plug-and-play options for later upgrades.

VLT® General purpose I/O MCB 101

3 digital inputs, 2 digital outputs,
 1 analogue current output,
 2 analogue voltage inputs

VLT® Relay Card MCB 105

3 relay outputs

VLT® Analogue I/O MCB 109

3 Pt1000/Ni1000 inputs,
 3 analogue voltage outputs
 Buffer for Real Time Clock

VLT® 24 V External Supply MCB 107

24 V DC external supply can be connected to supply control- and option cards.

Filters

- **Advanced Harmonic Filters:**
For critical demands on harmonic distortion
- **dU/dt filters:**
For special demands on motor isolation protection
- **Sine-Wave filters:**
For noiseless motor operation or special demands on motor isolation protection

PC software tools

- **VLT® Motion Control Tool MCT 10:**
Ideal for commissioning and servicing the drive

Specifications

Mains supply (L1, L2, L3)	
Supply voltage	200 – 240 V ±10% 380 – 480 V ±10% 525 – 600 V ±10%
Supply frequency	50/60 Hz
Displacement Power Factor (cos φ)	Near unity (> 0.98)
Switching on input supply L1, L2, L3	1-2 times/min.
Output data (U, V, W)	
Output voltage	0 – 100% of supply voltage
Switching on output	Unlimited
Ramp times	1 – 3600 sec.
Output frequency	0 – 590 Hz
Digital inputs	
Programmable digital inputs	6*
Logic	PNP or NPN
Voltage level	0 – 24 V
* 2 can be used as digital outputs	
Analogue input	
Analogue inputs	2
Modes	Voltage or current
Voltage level	0 – 10 V (scaleable)
Current level	0/4 to 20 mA (scaleable)
Relay outputs	
Programmable relay outputs	2 (240 VAC, 2 A and 400 VAC, 2 A)
Fieldbus communication	
Standard built-in:	Optional:
FC Protocol	VLT® AK-LonWorks MCA 107
Modbus RTU	VLT® PROFIBUS MCA 101
N2 Metasys	VLT® PROFINET MCA 120

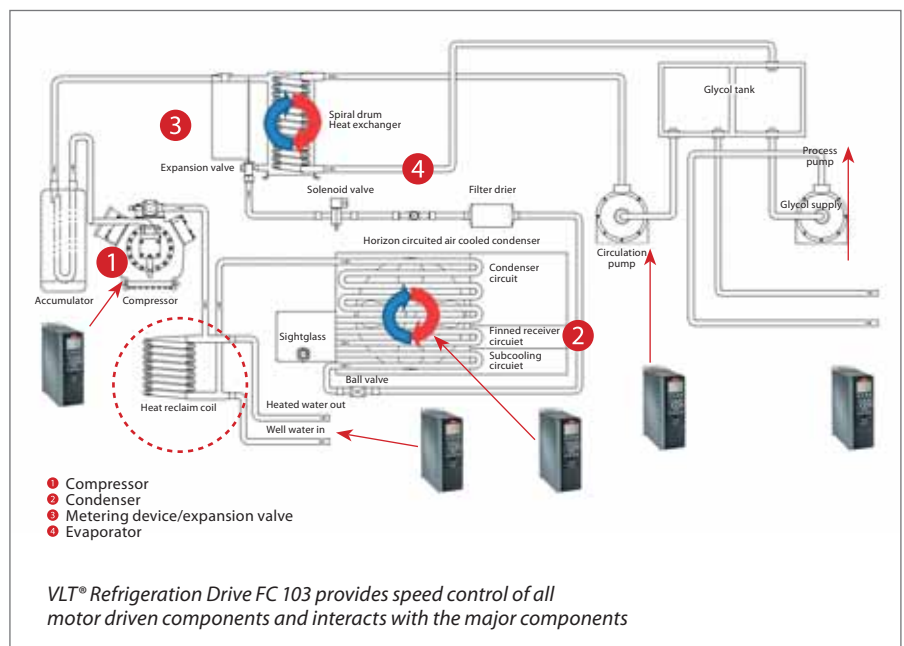

Current and power ratings

FC 103	kW	T2 200 – 240 V				T4 380 – 480 V					T6 525 – 600 V*								
		Amp.	IP 20	IP 21	IP 55	IP 66	Amp.		IP 20	IP 21	IP 54	IP 55	IP 66	Amp.		IP 20	IP 21	IP 55	IP 66
							≤440 V	>440 V						≤550 V	>550 V				
P1K1	1.1	6.6					3	2.7						2.6	2.4				
P1K5	1.5	7.5	A2	A2	A4/A5	A4/A5	4.1	3.4						2.9	2.7				
P2K2	2.2	10.6					5.6	4.8	A2	A2				4.1	3.9	A3	A3	A5	A5
P3K0	3	12.5					7.2	6.3						5.2	4.9				
P3K7	3.7	16.7	A3	A3	A5	A5													
P4K0	4.0						10	8.2	A2	A2				6.4	6.1				
P5K5	5.5	24.2					13	11	A3	A3				9.5	9	A3	A3	A5	A5
P7K5	7.5	30.8	B3	B1	B1	B1	16	14.5						11.5	11				
P11K	11	46.2					24	21						19	18				
P15K	15	59.4	B4	B2	B2	B2	32	27	B3	B1				23	22	B3	B1	B1	B1
P18K	18	74.8					37.5	34						28	27				
P22K	22	88	C3	C1	C1	C1	44	40						36	34				
P30K	30	115					61	52	B4	B2				43	41	B4	B2	B2	B2
P37K	37	143					73	65						54	52				
P45K	45	170	C4	C2	C2	C2	90	80						65	62	C3	C1	C1	C1
P55K	55						106	105	C3	C1				87	83				
P75K	75						147	130						105	100	C4	C2	C2	C2
P90K	90						177	160	C4	C2				137	131				
N110	110						212	190											
N132	132						260	240	D3h	D1h	D1h								
N160	160						315	302											
N200	200						395	361											
N250	250						480	443	D4h	D2h	D2h								
N315	315						588	535											

* available in US only

IP 00/Chassis	IP 20/Chassis	IP 21/Type 1	With upgrade kit – available in US only	IP 54/Type 12	IP 55/Type 12	IP 66/NEMA 4X
---------------	---------------	--------------	---	---------------	---------------	---------------

Dimensions [mm]

	A2	A3	A4	A5	B1	B2	B3	B4	C1	C2	C3	C4	D1h	D2h	D3h	D4h
H	268		390	420	480	650	399	520	680	770	550	660	901	1107	909	1122
W	90	130	200		242		165	231	308	370	308	370	325	420	250	350
D	205		175	200	260		248	242	310	335	333		378		375	
H+	375						475	670			755	950				
W+	90	130					165	255			329	391				

Note: H and W dimensions are with back-plate. H+ and W+ are with IP upgrade kit. D dimensions are without option. A or B for A2 and A3.

VLT® AQUA Drive



Dedicated

features for water applications

User friendly setup of water and pump settings reduces installation time ensuring maximum energy efficiency and motor control.

Optimized drive for AC motor driven water and wastewater applications. User friendly setup makes installation easy and enables owners to reach the highest level of performance and lowest cost of ownership.

Featuring a wide range of powerful, standard features, which can be expanded with performance improving options, the VLT® AQUA Drive is equally suited to both new and retrofit projects.

Set up the drive quickly and easily with the user friendly quick menu. By collecting the most important water and pump parameters in one place, the risk of incorrect configuration is reduced significantly.

Instantly benefit from high efficiency, fast payback and the lowest overall cost of ownership for water and wastewater applications.

Power range

1 x 200 – 240 V AC:	1.1 – 22 kW
1 x 380 – 480 V AC:	7.5 – 37 kW
3 x 200 – 240 V AC:	0.25 – 45 kW
3 x 380 – 480 V AC:	0.37 – 1000 kW
3 x 525 – 600 V AC:	0.75 – 90 kW
3 x 525 – 690 V AC:	11 – 1400 kW

Feature	Benefit
Dedicated features	
Dry run detection	Protects the pump
Flow compensation function	Saves energy
2 step ramps (initial/final ramp)	Protects deep well pumps
Check valve ramp	Protects against water hammering and saves installation cost for soft close valves
Pipe fill mode	Eliminates water hammering
Built-in motor alternation feature	Duty stand by operation, cost reduction
Sleep Mode	Saves energy
No/low flow detection	Protects the pump
End of pump-curve detection	Pump protection, leakage detection
Pump cascade controller	Lower equipment cost
Built-in Smart Logic Controller	Often makes PLC omissible
Deragging	Preventive/reactive pump cleaning
Back-channel cooling for frame D, E and F	Prolonged lifetime of electronics
Energy saving	
VLT® efficiency (98%)	Saves energy
Automatic Energy Optimisation (AEO)	Saves 3 – 8% energy
Auto Tuning of Staging Speeds	Smoothens the staging and saves energy
Reliable	
Maximum uptime	
IP 00 – IP 66 enclosures (depending on power size)	Choose the protection class you need
All power sizes available in IP 54/55 enclosures	Broad usability in standard enclosure
Password protection	Reliable operation
Mains disconnect switch	No need for external switch
Optional, built-in RFI suppression	No need for external modules
One Wire safe stop	Safe operation/less wiring
Max. ambient temperature up to 50°C without derating (D-frame 45°C)	Reduced need for cooling
User-friendly	
Save initial and operation cost	
One drive type for the full power range	Less learning required
Intuitive user interface	Time saved
Integrated Real Time Clock	Lower equipment cost
Modular design	Enables fast installation of options
Auto tuning of PI-controllers	Time saved
Payback time indication	Monitor performance

Application options

Extend the functionality of the drive with integrated options:

VLT® General Purpose I/O MCB 101

3 digital inputs, 2 digital outputs, 1 analogue current output, 2 analogue voltage inputs.

VLT® Extended Cascade Controller MCO 101, VLT® Advanced Cascade Controller MCO 102

Upgrade the built-in cascade controller to operate more pumps with higher energy efficiency using master/follower pump control. Run the pumps in use at the same speed and optimise staging speeds automatically during operation. Runtime of all pumps is balanced to distribute wear and tear evenly.

VLT® Sensor Input MCB 114

Monitors the PT100/PT1000 and protects motors from overheating.

VLT® PTC Thermistor Card MCB 112

The MCB 112 is connected to safe stop and protects the motor from overheating. It is approved for controlling a certified Ex proof motor in a potentially explosive atmosphere (ATEX) in zones 1 + 2 (gas) zones 21 + 22 (dust).

VLT® 24 V External Supply MCB 107

Back-up option to keep the control system alive during mains loss.

Coated PCB available

For harsh environments according to levels in IEC61721-3-3, standard 3C2, optional 3C3.

Relay & Analogue I/O option

(VLT® Relay Card MCB 105, VLT® Analog I/O MCB109)

Flexible I/O options adding 3 relays or 3 analogue inputs and 3 analogue outputs respectively.

High power options

See the VLT® High Power Drive Selection Guide for a complete list.

Specifications

Mains supply (L1, L2, L3)	
Supply voltage	200 – 240 V ±10%, 380 – 480 V ±10%, 525 – 600 V ±10%, 525 – 690 V ±10%
Supply frequency	50/60 Hz
Displacement Power Factor (cos φ) near unity	(> 0.98)
True power factor (λ)	≥ 0.9
Switching on input supply L1, L2, L3	1 – 2 times/min.
Output data (U, V, W)	
Output voltage	0 – 100% of supply
Switching on output	Unlimited
Ramp times	0.1 – 3600 sec.
Output frequency (dependent on power size)	590 Hz
<i>Note: VLT® AQUA Drive can provide 110% current for 1 minute. Higher overload rating is achieved by oversizing the drive.</i>	
Digital inputs	
Programmable digital inputs	6*
Logic	PNP or NPN
Voltage level	0 – 24 V DC
<i>* Two of the inputs can be used as digital outputs.</i>	
Analogue inputs	
Number of analogue inputs	2
Modes	Voltage or current
Voltage level	-10 to +10 V (scaleable)
Current level	0/4 to 20 mA (scaleable)
Pulse inputs	
Programmable pulse inputs	2
Voltage level	0 – 24 V DC (PNP positive logic)
Pulse input accuracy	(0.1 – 110 kHz)
<i>* Two of the digital inputs can be used for pulse inputs.</i>	
Analogue output	
Programmable analogue outputs	1
Current range at analogue output	0/4 – 20 mA
Relay outputs	
Programmable relay outputs	2 (240 VAC, 2 A and 400 VAC, 2 A)
Fieldbus Communication	
FC Protocol and Modbus RTU built-in (Optional: Modbus TCP, Profibus, Profinet, DeviceNet, Ethernet IP)	
Ambient temperature	
Up to 55° C (50° C without derating; D-frame 45° C)	

Power options

Choose from a wide range of external power options for use with our drive in critical networks or applications:

- **VLT® Low Harmonic Drive:** Optimum reduction of harmonic distortion with built-in active filter.
- **VLT® Advanced Harmonic Filter:** For applications where reducing harmonic distortion is critical.
- **VLT® dU/dt filter:** Provides motor isolation protection.
- **VLT® Sine-Wave filter:** For noiseless motor

PC software tools

- **VLT® Motion Control Tool MCT 10** Ideal for commissioning and servicing the drive, including guided programming of cascade controller, real time clock, smart logic controller and preventive maintenance.
- **VLT® Energy Box** Comprehensive energy analysis tool. Energy consumption with and w/o drive can be calculated (drive payback time). Online function for accessing drives energy log.
- **VLT® Motion Control Tool MCT 31** Harmonics calculations tool.

Current and power ratings

FC 202	kW	S2/T2 200 – 240 V								S4/T4 380 – 480 V						T6 525 – 600 V				T7 525 – 690 V																			
		1 ph				3 ph				1 ph		3 ph				Amp.				Amp.																			
		Amp.	IP 20	IP 21	IP 55	IP 66	IP 20	IP 21	IP 55	IP 66	≤440 V	>440 V	IP 21/55/66	≤440 V	>440 V	IP 00	IP 20	IP 21	IP 54	IP 55	IP 66	≤550 V	>550 V	IP 20	IP 21	IP 55	IP 66	550 V	690 V	IP 00	IP 20	IP 21	IP 54	IP 55	IP 66				
PK25	0.25	1.8																																					
PK37	0.37	2.4											1.3	1.2																									
PK55	0.55	3.5											1.8	1.6																									
PK75	0.75	4.6											2.4	2.1																									
P1K1	1.1	6.6	A3	A3	A5	A5	A2	A2	A4/A5	A4/A5			3	2.7	A2	A2						1.8	1.7												A5	A5			
P1K5	1.5	7.5											4.1	3.4								2.6	2.4																
P2K2	2.2	10.6											5.6	4.8								2.9	2.7	A3	A3	A5	A5									A3*			
P3K0	3	12.5		B1	B1	B1							7.2	6.3								4.1	3.9																
P3K7	3.7	16.7					A3	A3	A5	A5												5.2	4.9																
P4K0	4.0												10	8.2	A2	A2						6.4	6.1																
P5K5	5.5	24.2		B1	B1	B1							13	11								9.5	9	A3	A3	A5	A5									A3*			
P7K5	7.5	30.8		B2	B2	B2	B3	B1	B1	B1	33	30	B1	16	14.5	A3	A3					11.5	11													A5	A5		
P11K	11	46.2									48	41	B2	24	21							19	18																
P15K	15	59.4		C1	C1	C1							32	27	B3	B1						23	22	B3	B1	B1	B1												
P18K	18	74.8					B4				37.5	34	C1	37.5	34							28	27													B2	B2		
P22K	22	88		C2	C2	C2							44	40								36	34																
P30K	30	115					C3	C1	C1	C1			61	52	B4	B2					43	41	B4		B2	B2													
P37K	37	143									151	135	C2	73	65							54	52																
P45K	45	170											90	80								65	62	C3	C1	C1	C1											C2	
P55K	55												106	105								87	83														C2		
P75K	75												147	130								105	100																
P90K	90												177	160								137	131																
N75K	75																																						
N90K	90																																						
N110	110												212	190																									
N132	132												260	240	D3h	D1h/D5h/D6h	D1h/D5h/D6h																				D3h	D1h/D5h/D6h	
N160	160												315	302																									
N200	200												395	361																									
N250	250												480	443	D4h	D2h/D7h/D8h	D2h/D7h/D8h																						
N315	315												600	540																									
N400	400																																						
P315	315												600	540																									
P355	355												658	590	E2		E1	E1																					
P400	400												745	678																									
P450	450												800	730																									
P500	500												880	780																									
P560	560												990	890																									
P630	630												1120	1050																									
P710	710												1260	1160																									
P800	800												1460	1380																									
P900	900																																						
P1M0	1000												1720	1530																									
P1M2	1200																																						
P1M4	1400																																						

* Expected release: Q1, 2013

IP 00/Chassis	IP 20/Chassis	IP 21/Type 1	With upgrade kit – available in US only	IP 54/Type 12	IP 55/Type 12	IP 66/NEMA 4X
---------------	---------------	--------------	---	---------------	---------------	---------------

Dimensions [mm]

	A2	A3	A4	A5	B1	B2	B3	B4	C1	C2	C3	C4	D1h	D2h	D3h	D4h	D5h	D6h	D7h	D8h	E1	E2	F1	F2	F3	F4
H	268	390	420	480	650	399	520	680	770	550	660	901	1107	909	1122	1324	1665	1978	2284	2000	1547	2280	2280	2280	2280	
W	90	130	200	242	165	230	308	370	308	370	325	420	250	350	325	420	600	585	1400	1804	1997	2401				
D	205	175	200	260	249	242	310	335	333	378	375	381	384	402	494	498	607	607	607	607						
H+	375				475	670		755	950																	
W+	90	130			165	255		329	391																	

Note: H and W dimensions are with back-plate. H+ and W+ are with IP upgrade kit. D dimensions are without option. A or B for A2 and A3.

Option overview

An overview of available options for VLT® HVAC Drive, VLT® Refrigeration Drive, VLT® AQUA Drive, VLT® AutomationDrive, VLT® Lift Drive and VLT® Decentral Drive.

	Options	VLT® HVAC Drive	VLT® Refrigeration Drive	VLT® AQUA Drive	VLT® Automation Drive		VLT® Lift Drive	VLT® Decentral Drive	
		FC 102	FC 103	FC 202	FC 301	FC 302	LD 302	FCD 300	FCD 302
Slot A	VLT® PROFIBUS DP MCA 101	■	■	■	■	■		■	■
	VLT® PROFINET MCA 120	■	■	■	■	■			■
	VLT® DeviceNet MCA 104	■		■	■	■			
	VLT® DeviceNet Converter MCA 194					■			
	VLT® EtherNet/IP MCA 121	■		■	■	■			■
	VLT® CANopen MCA 105				■	■			
	VLT® EtherCAT MCA 124					■			■
	VLT® POWERLINK MCA 123				■	■			■
	VLT® LonWorks MCA 108	■							
	VLT® BACnet MCA 109	■							
	VLT® Modbus TCP MCA 122	■		■	■	■			
	VLT® PROFIBUS Converter MCA 113					■			
	VLT® PROFIBUS Converter MCA 114					■			
	VLT® AK-LonWorks MCA 107		■						
Slot B	VLT® General Purpose I/O MCB 101	■	■	■	■	■			
	VLT® Encoder Input MCB 102				■	■	■		
	VLT® Resolver Input MCB 103				■	■			
	VLT® Relay Card MCB 105	■	■	■	■	■			
	VLT® Safe PLC I/O MCB 108	■	■	■	■	■			
	VLT® Analog I/O Option MCB 109	■	■	■					
	VLT® PTC Thermistor Card MCB 112	■		■		■			
	VLT® Sensor Input MCB 114	■		■	■	■			
	VLT® Safe Option MCB 140 Series	■	■	■	■	■			
	VLT® Safe Option MCB 150 Series					■			
	VLT® Extended Cascade Controller MCO 101			■					
Slot C	VLT® Advanced Cascade Controller MCO 102			■					
	VLT® Motion Control MCO 305				■	■	■		
	VLT® Extended Relay Card MCB 113				■	■			
	VLT® Synchronizing Controller MCO 350				■	■			
	VLT® Position Controller MCO 351				■	■			
Slot D	VLT® Lift Controller MCO 361						■		
	VLT® 24 V Supply MCB 107	■	■	■	■	■			

VLT® Lift Drive



2.1 million

Load cycles

Is the minimum life time of the VLT® Lift Drive at 16 KHz frequency and 45 °C ambient temperature.

Developed specifically for lifts to provide reliable and excellent ride comfort. Operates without motor contactors and can be commissioned in less than 10 minutes.

Designed specifically for lifts

The VLT® Lift Drive's compact, rugged design is optimized for easy installation. Built in features ensure a long life of reliable operation, a smooth ride, and low total costs.

Easy commissioning with customized software

Setup and service is easily handled using the drive's dedicated software, which can be accessed at your convenience via the graphical display, VLT® Control Panel LCP 102. Read-outs are simple and clear, including the scope function that presents analog and digital data.

With parameterization tailored specifically for lifts all settings use "elevator language". This means that specialists are not required, as owners can set up and service their lift themselves in the shortest possible time.

Feature

Patented Safe Stop technology

IP 20, 21, 55, 66 protection rating

Dedicated lift functionality

Integrated RFI filter and DC coils

Benefit

- Save space
- Reduce costs for materials
- No switching noise
- Higher reliability

- Flexible installation options
- Mount the drive outside the lift cabinet

- Increases comfort during start-up, operation, and passenger entry/exit
- Very little noise from the lift shaft
- Reduces total system costs

- Reduces space requirements
- Lowers installation costs
- Easy compliance with EMC and harmonics standards

Operates without motor contactors

The patented Safe Stop function eliminates the need for motor contactors, increasing the reliability of the elevator installation, which is at least as safe as a solution with motor contactors.

An integrated RFI filter and DC coils eliminate the costly installation of external components. This reduces space requirements and eliminates a complex EMC-compliant wiring.

Power range

■ 4 – 55 kW (380-400 V) IP 20/21/55

Reliable in all environments

The Lift Drive can be installed in challenging ambient conditions outside the control of the variety of available housing and protection classes. For example, a unique feature of the Lift Drive means that when the temperature rises, the drive maintains the output current so that only the switching frequency is derated.

Specifications

Mains supply (L1, L2, L3)	
Supply voltage	380 – 400 V ±10%
Motor and Motor Feedback	
Load profile and lifetime expectancy	2.1 million load cycles
Motor feedback supported types	Incremental: 5V TTL (RS422) Incremental: 1Vpp SinCos Absolute: ENDAT, Hiperface
Acoustics	
Acoustic noise	55 dB
Maximum switching frequency	16 kHz
Environment	
Temperature operation	0 to 45°C
Enclosure IP protection	IP 20/21, IP 55
RFI filter	Included as standard

Power rating	4 kW			5.5 kW		7.5 kW		11 kW		15 kW	18 kW		22 kW	30 kW		37 kW	45 kW	55 kW	
IP Class	IP 20	IP 20	IP 55	IP 20	IP 55	IP 20	IP 55	IP 20	IP 55	IP 20	IP 20	IP 55	IP 20	IP 20	IP 55	IP 20	IP 20	IP 20	IP 55
Frame size	A2	A3	A5	A3	A5	B3	B1	B4	B4	B2	B4	C3	C1	C4	C4	C4	C4	C4	C2
Voltage [V]	400 V																		
Continuous output current 100%	10	13		16		26	21	35	44	35	51	60	50	75	90	110	98		
Overload 6s/60s [A]	16	20.8		26.6		46.8/ 41.6	33.6	60/ 56	74.4	56	91.3/ 81.6	180/ 90	75	135/ 112.5	162/ 135	198/ 165	147		
Current @ 16kHz [A]	10	13		16		N/A	N/A	32	35	35	44	N/A	50	N/A	N/A	N/A	N/A	N/A	N/A
Current @ 14kHz [A]	10	13		16		N/A	N/A	32	35	35	44	N/A	50	N/A	N/A	N/A	N/A	N/A	N/A
Current @ 12kHz [A]	10	13		16		21	21	35	44	35	51	60	50	75	83	98	98		
Current @ 10kHz [A]	10	13		16		26	21	35	44	35	51	60	50	75	90	98	98		
Current @ 8kHz [A]	10	13		16		26	21	35	44	35	51	60	50	75	90	110	98		
Ambient temperature	45 °C																		
Duty cycle	50%																		

VLT® 2800 Series



18.5 kW

maximum motor size

Energy efficient control of a wide range of applications, with built-in brake chopper and coated printed circuit board as standard features.

The multi purpose drive with a perfect match between price and performance in a wide range of industrial applications.

The VLT® 2800 series is designed to fit the needs in a wide range of general purpose drive applications up to 18.5 kW.

Over the years it has shown its value to a large number of customers, resulting in a large base of installed drives all over the world.

The VLT® 2800 is delivered with a factory fitted brake chopper and coated printed circuit boards for increased protection as standard features.

Power range

1/3 x 200 – 240 V 0.37 – 3.7 kW
 3 x 380 – 480 V 0.55 – 18.5 kW

With 160% overload torque (normal overload)

Feature	Benefit
Easy to integrate and operate	
Quick menu	Easy start-up and fast parameter access
Automatic Motor Tuning	Ensures optimal match and performance increase between VLT 2800 and motor
PID-controller	Optimized process control
Fieldbus communication	Control and surveillance from PLC or PC
Built-in brake chopper	Standard feature that increases flexibility. Eliminates need to decide up front if a brake chopper is needed
Application dedication	
Counter precise stop	The drive counts pulses and stops safely after the programmed number of counts.
Precise stop function	Increases performance in packaging applications
Dry run protection	Protects the pump in dry run situations
Enhanced sleep mode	Excellent control for shutting down the drive in low flow situations
Pipe fill mode	Prevents water hammering in pump applications
Flexible and robust	
Max. ambient temperature 45°C without derating	No external cooling or oversizing required
Mounting with ventilated heat sink	Flexible mounting incl. horizontal mounting
Side by side mounting	Saves space in installations
Built-in RFI filter	Complies with EMC standards incl. EN55011 1A
Coated Printed Circuit Boards	Standard feature that increases protection of electronics against condensation and hazardous substances in the surroundings

PC software tools

- **VLT® Motion Control Tool MCT 10:**
Ideal for commissioning and servicing the drive.
- **VLT® Motion Control Tool MCT 31:**
Harmonics calculations tool.

RFI filter

The RFI filter ensures that the frequency converter will not disrupt other electrical components that are connected to the mains and might cause operating disruption.

By fitting an RFI 1B filter module between the mains supply and the VLT® 2800, the solution complies with the EMC norm EN 55011-1B.

Mains	Type	Power		Input current	
		$P_{N,M}$ [kW]	I_{INV} [A]	$I_{L,N}$ [A]	
1 x 220–240 V	2803	0.37	2.2	5.9	
	2805	0.55	3.2	8.3	
	2807	0.75	4.2	10.6	
	2811	1.1	6.0	14.5	
	2815	1.5	6.8	15.2	
	2822*	2.2	9.6	22.0	
	2840*	3.7	16.0	31.0	
3 x 200–240 V	2803	0.37	2.2	2.9	
	2805	0.55	3.2	4.0	
	2807	0.75	4.2	5.1	
	2811	1.1	6.0	7.0	
	2815	1.5	6.8	7.6	
	2822	2.2	9.6	8.8	
	2840	3.7	16.0	14.7	
3 x 380–480 V	2805	0.55	1.7	1.6	
	2807	0.75	2.1	1.9	
	2811	1.1	3.0	2.6	
	2815	1.5	3.7	3.2	
	2822	2.2	5.2	4.7	
	2830	3.0	7.0	6.1	
	2840	4.0	9.1	8.1	
	2855	5.5	12	10.6	
	2875	7.5	16	14.9	
	2880	11.0	24	24.0	
2881	15.0	32	32.0		
2882	18.5	37.5	37.5		

* Not available with RFI filter

Specifications

Mains supply (L1, L2, L3)	
Supply voltage	200-240 V ±10%, 380-480 V ±10%
Supply frequency	50/60 Hz
Displacement Power Factor (cos φ) near unity	(> 0.98)
Switching on input supply L1, L2, L3	1–2 times/min.
Output data (U, V, W)	
Output voltage	0–100% of supply voltage
Switching on output	Unlimited
Ramp times	0.02–3600 sec.
Output frequency	0–590 Hz
Digital inputs	
For start/stop, reset, thermistor, etc.	5
Logic	PNP or NPN
Voltage level	0–24 VDC
Analogue input	
No. of analogue inputs	2
Voltage level	-10 to +10 V (scaleable)
Current level	0/4 to 20 mA (scaleable)
Pulse inputs	
No. of pulse inputs	2
Voltage level	0 – 24 V DC (PNP positive logic)
Pulse input accuracy	(0.1–110 kHz)
Digital output	
No. of digital outputs	1
Analogue output	
Programmable analogue outputs	1
Current range	0/4–20 mA
Relay outputs	
No. of relay outputs	1
Communication	
Standard built-in	RS485 Modbus RTU Metasys N2 protocols
Fieldbus built-in	PROFIBUS DP V1 12 Mbit/s DeviceNet
Ambient temperature	
	50°C

Cabinet sizes [mm]

Height				
	A	B	C	D
A	200	267.5	267.5	505
a	191	257	257	490
Width				
	B			
B	75	90	140	200
b	60	70	120	120
Depth				
	C			
C	168	168	168	244

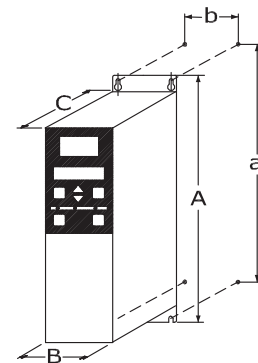

VLT® Micro Drive



The VLT® Micro Drive is a general purpose drive that can control AC motors up to 22 kW. It's a small drive with maximum strength and reliability.

VLT® Micro Drive is a full member of the VLT® family sharing the overall quality of design, reliability and user-friendliness.

Due to high quality components and genuine VLT® solutions, VLT® Micro Drive is extremely reliable.

RoHS compliant

The VLT® Micro Drive is manufactured with respect for the environment, and it complies with the RoHS Directive.

Power range

1 phase 200–240 V AC 0.18–2.2 kW
 3 phase 200–240 V AC 0.25–3.7 kW
 3 phase 380–480 V AC 0.37–22 kW

Feature	Benefit
User friendly	
Minimum commissioning	Saves time
Mount – connect – go!	Minimum effort – minimum time
Copy settings via local control panel	Easy programming of multiple drives
Intuitive parameter structure	Minimal manual reading
Complies with VLT® software	Saves commissioning time
Self-protecting features	Lean operation
Process PI-controller	No need for external controller
Automatic Motor Tuning	Ensure optimal match between drive and motor
150% motor torque up to 1 minute	Plenty of brake-away and acceleration torque
Flying start (catch a spinning motor)	Doesn't trip when started on a spinning (freewheeling) motor
Electronic Thermal Relay (ETR)	Replaces external motor protection
Smart Logic Controller	Often makes PLC unnecessary
Built-in RFI filter	Saves cost and space
Energy saving	
Energy efficiency 98%	Minimises heat loss
Automatic Energy Optimisation (AEO)	Saves 5-15% energy in HVAC applications
Reliable	
Earth fault protection	Protects the drive
Over temperature protection	Protects the motor and drive
Short circuit protection	Protects the drive
Optimum heat dissipation	Longer lifetime
Unique cooling concept with no forced air flow over electronics	Problem-free operation in harsh environments
High quality electronics	Low lifetime cost
High quality capacitors	Tolerates uneven mains supply
All drives full load tested from factory	High reliability
Dust resistant	Increased lifetime
RoHS compliant	Protects the environment
Designed for WEEE	Protects the environment

Coated PCB standard

For harsh environments.

Power options

Danfoss VLT Drives offers a range of external power options for use together with our drives in critical networks or applications:

- **VLT® Advanced Harmonic Filter:**
For applications where reducing harmonic distortion is critical.

PC software tools

- **VLT® Motion Control Tool MCT 10:**
Ideal for commissioning and servicing the drive including guided programming of cascade controller, real time clock, smart logic controller and preventive maintenance.
- **VLT® Energy Box:**
Comprehensive energy analysis tool, shows the drive payback time.
- **VLT® Motion Control Tool MCT 31:**
Harmonics calculations tool.



Cabinet sizes

(mounting flange incl.)

[mm]	M1	M2	M3	M4	M5
Height	150	176	239	292	335
Width	70	75	90	125	165
Depth	148	168	194	241	248

+ 6 mm with potentiometer

Specifications

Mains supply (L1, L2, L3)	
Supply voltage	1 x 200–240 V ± 10%, 3 x 200–240 V ± 10% 3 x 380–480 V ± 10%
Supply frequency	50/60 Hz
Displacement Power Factor (cos φ) near unity	(> 0.98)
Switching on input supply L1, L2, L3	1–2 times/min.
Output data (U, V, W)	
Output voltage	0–100% of supply voltage
Output frequency	0–200 Hz (VVC+ mode), 0–400 Hz (U/f mode)
Switching on output	Unlimited
Ramp times	0.05–3600 sec
Digital inputs	
Programmable digital inputs	5
Logic	PNP or NPN
Voltage level	0–24 VDC
Pulse inputs	
Programmable pulse inputs	1*
Voltage level	0–24 V DC (PNP positive logic)
Pulse input frequency	20–5000 Hz

* One of the digital inputs can be used for pulse inputs.

Analogue input	
Analogue inputs	2
Modes	1 current/1 voltage or current
Voltage level	0–10 V (scaleable)
Current level	0/4 to 20 mA (scaleable)
Analogue output	
Programmable analog outputs	1
Current range at analog output	0/4–20 mA
Relay outputs	
Programmable relay outputs	1 (240 VAC, 2 A)
Approvals	
CE, C-tick, UL	
Fieldbus communication	
FC Protocol, Modbus RTU	

Ordering numbers

Power [kW]	200 V		400 V		
	Current [I-nom.]	1 ph.	3 ph.	Current [I-nom.]	3 ph.
0.18	1.2	132F 0001			
0.25	1.5		132F 0008		
0.37	2.2	132F 0002	132F 0009	1.2	132F 0017
0.75	4.2	132F 0003	132F 0010	2.2	132F 0018
1.5	6.8	132F 0005	132F 0012	3.7	132F 0020
2.2	9.6	132F 0007	132F 0014	5.3	132F 0022
3.0				7.2	132F 0024
3.7	15.2		132F 0016		
4.0				9.0	132F 0026
5.5				12.0	132F 0028
7.5				15.5	132F 0030
11.0				23.0	132F 0058
15.0				31.0	132F 0059
18.5				37.0	132F 0060
22.0				43.0	132F 0061

Micro drives from 1.5 kW and up have built in brake chopper

VLT® Control Panel LCP 11 Without potentiometer: 132B0100
 VLT® Control Panel LCP 12 With potentiometer: 132B0101

VLT® Decentral Drive FCD 302



IP 66

enclosure

for conveyor applications, installations in wash-down areas or widely distributed applications with a large number of drives

The VLT® Decentral Drive FCD 302 is the new generation of the VLT® Decentral Drive FCD 300, based on the VLT® AutomationDrive FC 302 platform. Combining the key features of both products in a completely re-designed enclosure, the drive is made for the best fit for direct machine mounting.

Designed for simplicity and robustness the new VLT® Decentral Drive FCD 302 is a user-friendly product with high performance and strong protection degree.

Decentral drives are meant for decentral mounting, eliminating the need for space-consuming control cabinets. With the drives placed near the motor, there is no need for long screened motor cables.

One-box concept

All options are built into the unit, reducing the number of boxes to be mounted, connections and terminations in the installation. Consequently labor costs for mounting and risk of failures are dramatically reduced.

Power range

0.37 – 3 kW, 3 x 380 – 480 V

Feature	Benefit
Reliable	Maximum uptime
Pluggable twin-part design (installation box and electronic part)	Easy and fast service
Integrated lockable service switch available	Local disconnection possible
User-friendly	Saves commissioning and operation cost
Smooth surface	Easy cleaning; no dirt trap
Adapts to any brand of motor and geared motor, induction as well as permanent magnet motors	Easy and flexible installation
Integrated power and fieldbus looping terminals	Cable savings
Visible LEDs	Quick status check
Set-up and control through pluggable control panel, fieldbus communication and set-up software VLT® Motion Control Tool MCT 10	Easy commissioning
Awarded control panel with on-board manual (accessory)	Easy operation
Screwless spring-loaded terminals	Easy and fast connection
Integrated USB port	Direct connection to PC
Intelligent	Built-in feature
Smart Logic Control	Reduces need for PLC capacity
Safe Torque Off (Safe Stop) as standard	Reduces the need for extra components
Intelligent warning systems	Warning before controlled stop

Enclosure

- IP 66 standard black
 - IP 66 standard white
 - IP 66 hygienic white
- (all enclosures are rated as NEMA 4X)

Integrated 24 V supply

24 V DC control supply is provided by the drive. Separate supply terminals have been made for remote I/Os distribution.

Power looping

The new FCD 302 facilitates internal power looping. Terminals for 6 mm² (big box) or 4 mm² (small box) power cable inside the enclosure allows connection of multiple units in the same branch.

Ethernet switch

Integrated Ethernet switch/ hub with the two RJ-45 ports are available in the drive for easy daisy-chaining of Ethernet communication. Fieldbuses are routed easily, without adding commissioning time, by connecting Ethernet or Profibus based fieldbuses to a M12 pluggable interface.

Safety

The VLT® Decentral Drive FCD 302 is delivered as standard with the Safe Torque Off (Safe Stop) function in compliance with EN ISO 13849-1 Category 3 PL d and SIL 2 according to IEC 61508 low demand and high demand mode.

Fieldbus options

(integrated into the control card)

- PROFIBUS DP
- PROFINET
- EtherNet/IP
- EtherCAT
- POWERLINK

Application options

- VLT® Encoder Input MCB 102
- VLT® Resolver Input MCB 103
- VLT® Safe PLC I/O MCB 108

Hardware options

- Mounting brackets
- Service switch
- Internal circuit breaker
- M12 sensor plugs
- 24 V DC input for control supply
- Brake chopper
- Electromechanical brake control and supply
- Fieldbus plugs

Specifications

Mains supply (L1, L2, L3)	
Supply voltage	380 – 480 V ±10%
Supply frequency	50/60 Hz
True Power Factor (λ)	0.92 nominal at rated load
Displacement Power Factor (cos φ)	(>0.98)
Switching on input supply	2 times/min.
Output data (U, V, W)	
Output voltage	0 – 100% of supply
Output frequency	0 – 590 Hz 0 – 300 Hz (Flux mode)
Switching on output	Unlimited
Ramp times	0.01 – 3600 sec.
Digital inputs	
Programmable digital inputs	4 (6)
Logic	PNP or NPN
Voltage level	0 – 24 V DC
<i>Note: One/two digital inputs can be programmed as digital output</i>	
Analogue inputs	
Number of analogue inputs	2
Modes	Voltage or current
Voltage level	-10 to +10 V (scaleable)
Current level	0/4 – 20 mA (scaleable)
Pulse/encoder inputs	
Programmable pulse/encoder inputs	2
Voltage level	0 – 24 V DC (PNP positive logic)
Digital output	
Programmable digital/pulse outputs	2
Voltage level at digital/frequency output	0 – 24 V
Analogue output	
Programmable analogue outputs	1
Current range	0/4 – 20 mA
Relay outputs	
Programmable relay outputs	2
Integrated 24 V supply	
Max. load	600 mA

Dimensions

Small frame

(0.37 – 2.2 kW/0.5 – 3.0 HP)

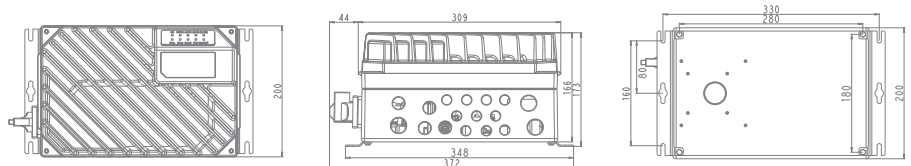

Large frame

(0.37 – 3 kW/0.5 – 4.0 HP)

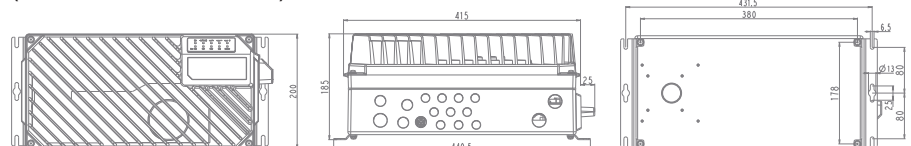

All measurements are in mm

VLT® Decentral Drive FCD 300



The VLT® Decentral Drive FCD 300 is a complete frequency converter designed for decentral mounting. It can be mounted on the machine or wall close to the motor, or directly on the motor.

The VLT® Decentral Drive FCD 300 comes in very robust enclosure, with a special painting treatment to withstand harsh environments and typical cleaning agents used in wash-down areas. Its design offers a smooth cleaning-friendly surface.

The decentral design reduces the need for central control panels and eliminates the need for space-consuming motor control cabinets. The need for long screened motor cables is significantly reduced.

Power range

0.37 – 3.3 kW, 3 x 380 – 480 V

Enclosure

IP 66/Type 4X (indoor)

Feature	Benefit
Reliable	Maximum uptime
Special surface treatment as protection against aggressive environments	Easy cleaning; no dirt trap
Twin part design (installation box and electronic part)	Easy and fast service
Integrated lockable service switch available	Local disconnection possible
Full protection is offered	Protects the motor and drive
User-friendly	Saves commissioning and operating cost
Adapts to any brand of motor and geared motor	Easy and flexible installation
Designed for power and fieldbus looping	Cable savings
Visible LEDs	Quick status check
Set-up and controlled through a remote control panel or fieldbus communication and dedicated MCT 10 set-up software	Easy commissioning

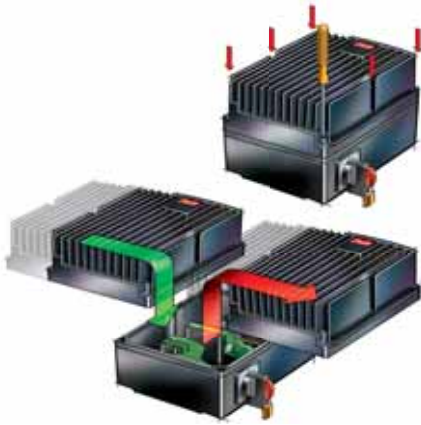

Plug-and-drive

The bottom section contains maintenance-free Cage Clamp connectors and looping facilities for power and fieldbus cables. Once installed, commissioning and upgrading can be performed in no time by plugging in another control lid.

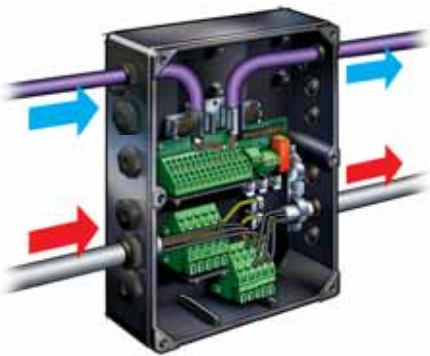

Flexible installation

The FCD 300 series facilitates internal power line and fieldbus looping. Terminals for 4 mm² power cables inside the enclosure allows connection of up to 10+ units.

Available options

- Service switch
- Connector for control panel
- M12 connectors for external sensors
- Han 10E motor connector
- Brake chopper and resistor
- 24 V external back up of control and communication
- External electromechanical brake control and supply

Specifications

Mains supply (L1, L2, L3)	
Supply voltage	3 x 380/400/415/440/480 V ± 10%
Supply frequency	50/60 Hz
Max. imbalance on supply voltage	±2.0% of rated supply voltage
Switching on input supply	2 times/min.
Power Factor (cos φ)	0.9 / 1.0 at rated load
Output data (U, V, W)	
Output voltage	0–100% of supply
Overload torque	160% for 60 sec.
Switching on output	Unlimited
Ramp times	0.02 - 3600 sec.
Output frequency	0.2 - 132 Hz, 1 - 1000 Hz
Digital inputs	
Programmable digital inputs	5
Voltage level	0–24 V DC (PNP positive logic)
Analog inputs	
Analog inputs	2 (1 voltage, 1 current)
Voltage level/Current level	0– ±10 V DC / 0/4–20 mA (scaleables)
Pulse inputs	
Programmable pulse inputs	2 (24 V DC)
Max. frequency	110 kHz (push-pull) / 5 kHz (open collector)
Analog output	
Programmable analog output	1
Current range	0/4–20 mA
Digital output	
Programmable digital/frequency output	1
Voltage/frequency level	24 V DC/10 kHz (max.)
Relay output	
Programmable relay output	1
Max. terminal load	250 V AC, 2 A, 500 VA
Fieldbus communication	
FC Protocol, Modbus RTU, Metasys N2	Built-in
Profibus DP, DeviceNet, AS-interface	Optional (integrated)
Externals	
Vibration test	1.0 g (IEC 60068)
Max. relative humidity	95 % (IEC 60068-2-3)
Ambient temperature	Max. 40°C (24 hour average max. 35°C)
Min. ambient temperature in full operation	0°C
Min. ambient temperature at reduced performance	-10°C
Approvals	CE, UL, C-tick, ATEX*

* Contact Danfoss for details

Technical data

VLT® Decentral FCD		303	305	307	311	315	322	330	335*
Output current (3 x 380 – 480 V)	I _{INV (60s)} [A]	1.4	1.8	2.2	3.0	3.7	5.2	7.0	7.6
	I _{MAX (60s)} [A]	2.2	2.9	3.5	4.8	5.9	8.3	11.2	11.4
Output power (400 V)	S _{INV} [KVA]	1.0	1.2	1.5	2.0	2.6	3.6	4.8	5.3
	P _{M,N} [kW]	0.37	0.55	0.75	1.1	1.5	2.2	3.0	3.3
Typical shaft output	P _{M,N} [HP]	0.5	0.75	1.0	1.5	2.0	3.0	4.0	5.0
	Mechanical dimensions H x W x D (mm)	Motor mounting	244 x 192 x 142					300 x 258 x 151	
	Stand alone	300 x 192 x 145					367 x 258 x 154		

* t_{amb} max. 35°C

VLT® DriveMotor FCP 106



IE4

efficiency

The VLT® DriveMotor FCP 106 complies with both IE3 and IE4 (for EN 60034-30-1) efficiency requirements.

Standalone frequency converter for mounting on any standard induction or permanent magnet motor from 0.55 – 7.5 kW.

With a wide range of standard integrated pump and fan features, the VLT® DriveMotor FCP 106 can provide efficient control of motors in the 0.55 – 7.5 kW range.

By mounting the drive directly on the motor, owners are free to choose their own manufacturer and design the optimal system for their application. Once attached to the motor the drive automatically sets the optimal parameters to provide stable, energy efficient operation.

The FCP 106 is the perfect solution for both OEMs and end-users. By mounting the drive directly on the motor, with an adjustable adaptor plate, you eliminate the need for cabinets and reduce cable costs significantly.

Setup is easy with Danfoss VLT® Motion Control Tool MCT 10.

Compatible with VLT® DriveMotor FCM 300

The FCP 106 can be retrofitted on a FCM 300 motor with an adaptor plate.

Feature	Benefit
Alphanumerical display, 7 languages	Effective commissioning
External connection for display as standard	Fast connectivity
Motor data pre-programmed	No programming needed
IP 55/66 enclosure	Reliable in wet and dirty environments
PCB protection class 3C3	Reliable in corrosive environments
Vibration up to 2 g/shock 25 g (3M6: IEC721-3-3)	Suitable for all motor mounted challenges
110% overload (0.55 – 7.5 kW)	Optimised for fans and pumps
160% overload (0.55 – 5.5 kW)	High starting torque
Asynchronous or permanent magnet motor	Free choice of motor technology
Sleep mode	Save energy and extend lifetime
Automatic Energy Optimizer function	Saves an additional 5-15% energy
AHU dedicated functions	Reduces cost and saves energy
Pump dedicated functions	Protects the pump and extends the lifetime
Built-in PI controller	No external PI controller required
Smart Logic Controller	Often makes PLC/DDC unnecessary
Control signal for mechanical brake	Reduce effort in PLC
FC Protocol, Modbus, Metasys, BACnet, integrated	Flexible connectivity
Integrated DC link	Meets EN 61000-6-12, small power cable
Integrated EMC filters	Meets EN 61800-3, (C1 and C2), and EN 55011 Class (B and A1)

Power range

3 x 380 – 480 V..... 0.55 – 7.5 kW
 (with 110% overload torque)
 3 x 380 – 480 V..... 0.55 – 5.5 kW
 (with 160% overload torque)

Enclosure ratings

IP 66 (NEMA 4X)..... 0.55 – 7.5 kW

VLT® Control Panel LCP 31 (LCP only)

Alphanumerical display for commissioning and status indication during operation. Connection easy accessible through cable gland.

Ordering number: 132B0200

VLT® Control Panel LCP 31 Mounting Kit

Including 3 m cable, panel mounting bracket, gasket and fasteners.

Ordering number: 134B0557

Local Operation Pad LOP

Panel for start/stop and setting the reference.

Ordering number: 175N0128

Potentiometer for cable gland

For setting the reference directly at the drive.

Ordering number: 177N0011

PC software tool:

VLT® Motion Control Tool MCT 10

Ideal for commissioning and servicing the drive with induction motor attached.



Mount the FCP 106 on your preferred motor.

Specifications

Mains supply (L1, L2, L3)	
Supply voltage	380 – 480 V ±10%
Supply frequency	50/60 Hz
Displacement Power Factor (cos φ)	near unity (> 0.98)
Switching on input supply L1, L2, L3	1–2 times/min.
Output data (U, V, W)	
Output voltage	0 – 100% of supply voltage
Switching on output	Unlimited
Ramp times	1–3600 sec.
Output frequency	0 – 200 Hz
Digital inputs	
Programmable digital inputs	4
Logic	PNP or NPN
Voltage level	24 V
Analogue input	
Analogue inputs	2
Modes	Voltage and current
Voltage level	0 – 10 V (scaleable)
Current level	0/4 to 20 mA (scaleable)
Digital/Analogue Output	
Programmable outputs	2
Analogue output current level	0/4 to 20 mA (scaleable)
Relay output	
Programmable relay outputs	2 (resistive load 250 VAC, 3 A 30VDC, 2A)

Additional features when mounting the electronic (FCP 106) on your motor

Note your production info into the drive	Identification of your programming
Change motor data to fit your motor	Optimize settings for your motor settings
Create new factory settings (CSIV Technology)	Ensure correct motor data settings
Motor cable length upto 0,5m	Mount FCP on every side of the motor
Custom adapter plate	Mount FCP on every motor make
Oversized FCP can be mounted on motor	Higher overload for critical applications
Motor independent cooling	FCP fits on any motor

Dimensions

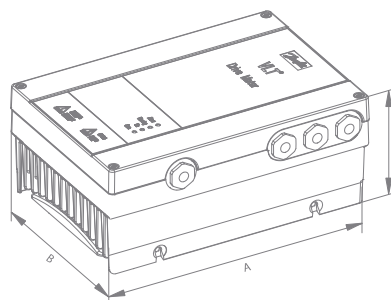

Dimensions (mm)	Length	Width	Height
	A	B	C
MH1	231	162	107
MH2	277	187	113
MH3	322	220	124

VLT® DriveMotor FCM 106



IE4

efficiency

The VLT® DriveMotor FCM 106 complies with both IE3 and IE4 (for EN 60034-30-1) efficiency requirements.

Easy to install and delivered with either permanent magnet or standard induction motor mounted.

With a wide range of standard, integrated pump and fan features, the VLT® DriveMotor FCM 106 is a highly dedicated, space saving motor and control solution in the 0.55-7.5 kW range.

The drive is delivered from the factory mounted to either a standard induction motor or a size optimized permanent magnet motor.

This enables the FCM 106 to reduce both installation costs and complexity significantly. The compact design of the motor mounted drive solution also eliminates the need for cabinets.

Due to the fact that the drive is mounted directly on the motor, long motor cables are eliminated, reducing costs further for both OEMs and end users. A plug connects the drive to the motor making assembly/disassembly fast and service friendly.

The DriveMotor is part of Danfoss EC+ concept, which maximizes the advantages and efficiency of permanent magnet motors, variable speed drives and plugfan technologies.

Feature	Benefit
Alphanumerical display, 7 languages	Effective commissioning
External connection for display as standard	Fast connectivity
Motor data pre-programmed	No programming needed
IP 66 (drive) / IP 55 (motor)	Reliable in wet and dirty environments
PCB protection class 3C3	Reliable in corrosive environments
Vibration up to 2 g / shock 25 g (3M6: IEC721-3-3)	Suitable for all motor-mounted challenges
110% overload (0.55 – 7.5 kW)	Optimised for fans and pumps
160% overload (0.55 – 5.5 kW)	High starting torque
Asynchronous or permanent magnet motor	Free choice of motor technology
Sleep mode	Save energy and extend lifetime
Automatic Energy Optimizer function	Saves an additional 5 – 15% energy
AHU dedicated functions	Reduces cost and saves energy
Pump dedicated functions	Protects the pump and extends the lifetime
Built-in PI controller	No external PI controller required
Smart Logic Controller	Often makes PLC/ DDC unnecessary
Control signal for mechanical brake	Reduce effort in PLC
FC Protocol, Modbus, Metasys, BACnet, integrated	Flexible connectivity
Integrated DC link	Meets EN 61000-6-12, small power cable
Integrated EMC filters	Meets EN 61800-3, (C1 and C2), and EN 55011 Class (B and A1)

Power range

3 x 380 – 480 V 0.55 – 7.5 kW
(with 110% overload torque)

3 x 380 – 480 V 0.55 – 5.5 kW
(with 160% overload torque)

Enclosure ratings

IP 66 (UL type 4X outdoor)
0.55 – 7.5 kW

VLT® Control Panel LCP 31 (LCP only)

Alphanumerical display for commissioning and status indication during operation. Connection easy accessible through cable gland.

Ordering number: 132B0200

VLT® Control Panel LCP 31 Mounting Kit

Including 3 m cable, panel mounting bracket, gasket and fasteners.

Ordering number: 134B0557

Local Operation Pad LOP

Panel for start/stop and setting the reference.

Ordering number: 175N0128

Potentiometer for cable gland

For setting the reference directly at the drive.

Ordering number: 177N0011

PC software tool:

VLT® Motion Control Tool MCT 10

Ideal for commissioning and servicing the drive with induction motor attached.



Choose the FCM 106 with a standard induction motor or permanent magnet motor.

Specifications

Mains supply (L1, L2, L3)	
Supply voltage	380 – 480 V ±10%
Supply frequency	50/60 Hz
Displacement Power Factor (cos φ)	near unity (> 0.98)
Switching on input supply L1, L2, L3	1–2 times/min.
Output data (U, V, W)	
Output voltage	0 – 100% of supply voltage
Switching on output	Unlimited
Ramp times	1–3600 sec.
Output frequency	IM: 0 – 200 Hz / PM: 0 – 390 Hz
Digital inputs	
Programmable digital inputs	4
Logic	PNP or NPN
Voltage level	24V
Analogue input	
Analogue inputs	2
Modes	Voltage and current
Voltage level	0 – 10 V (scaleable)
Current level	0/4 to 20 mA (scaleable)
Digital/Analogue Output	
Programmable outputs	2
Analogue output current level	0/4 to 20 mA (scaleable)
Relay output	
Programmable relay outputs	2 (resistive load 250 VAC, 3 A 30VDC, 2A)

IEC Standard Motor Frame Sizes

PM 1500 rpm	PM 3000 rpm	IM 3000 rpm	IM 1500 rpm	MH frame size	kW
71	NA	NA	NA	MH1	0.55
71	71	71	80		0.75
71	71	80	90		1.1
71	71	80	90		1.5
90	71	90	100	MH2	2.2
90	90	90	100		3
90	90	100	112		4
112	90	112	112	MH3	5.5
112	112	112	132		7.5

VLT® DriveMotor FCM 300



IE2

motors for high efficiency

combined with a high-performance, energy saving VLT®.



The VLT® DriveMotor FCM 300 Series is an integrated drive-motor solution which combines a VLT® frequency converter and a high standard quality motor in a single product.

The frequency converter is attached in place of the motor terminal box and it is no higher than the standard terminal box nor wider or longer than the motor.

Incorporated to a high standard quality motor, the VLT® DriveMotor FCM 300 is also available in a multitude of variants, individualised to meet customer requirements.

On the motor

The VLT® electronic motor control together with the motor totally eliminates motor cables and thereby minimises EMC problems. Heat from the drive is dissipated together with the motor heat.

Power range

0.55 – 7.5 kW, 3 x 380 – 480 V

Feature	Benefit
Reliable	Maximum uptime
Robust enclosure	Withstands harsh environments
No power cable length limitation	Increased flexibility
Thermal protection	Total motor-inverter protection
Straightforward EMC compliance	No problem with electromagnetic interferences
User-friendly	Saves commissioning and operating cost
Motor and drive perfectly matched to each other	Saves commissioning time
No panel space required – the DriveMotor is placed on the machine	Saves space
Flexible mounting – foot/flange/face/foot-flange/foot-face	Meets customer requirements
Retrofit without mechanical changes	Easy service
Set-up and controlled through a remote control panel or fieldbus communication and dedicated MCT 10 set-up software	Easy commissioning

Enclosure

IP 55 (standard)
IP 65/IP 66 (optional)

Motor type

2-pole
4-pole

Mounting versions

B03 foot
B05 flange
B35 foot + flange
B14 face
B34 foot + face



Control panel

A Local Control Panel is available for operating, setup and diagnostics. The LCP can be handheld or mounted in a panel front (IP65).

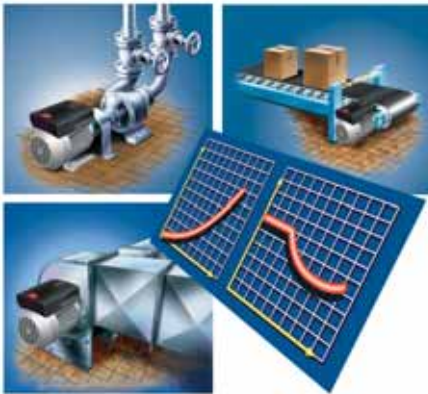

Sleep Mode

In Sleep Mode the motor will stop in a no load situation. When the load returns, the frequency converter will restart the motor.

Motor drain holes

For applications where formation of condensate water might occur.

Sensorless Pump Control – OEM version

Offers precise pressure (head) control without using a pressure transmitter.

Specifications

Mains supply (L1, L2, L3)	
Supply voltage	3 x 380/400/415/440/460/480V ± 10%
Supply frequency	50/60 Hz
Power factor (cos φ)	Max. 0.9/1.0 at rated load
Max. imbalance of supply voltage	± 2% of rated supply voltage
Switching on supply input	Once every 2 minutes
Control Characteristics (frequency converter)	
Frequency range	0 – 132 Hz
Overload torque	160% for 60 sec.
Resolution on output frequency	0.1%
System response time	30 msec. ± 10 msec.
Speed accuracy	± 15 RPM (open loop, CT mode, 4-pole motor 150 – 1500 RPM)
Digital inputs	
Programmable digital inputs	4
Voltage level	0 – 24 V DC (PNP positive logic)
Analog inputs	
Analog inputs	2 (1 voltage, 1 current)
Voltage/current level	0 – 10 V DC / 0/4 – 20 mA (scaleables)
Pulse input	
Programmable pulse input	1 (24 V DC)
Max. frequency	70 kHz (push-pull) / 8 kHz (open collector)
Analog/digital output	
Programmable analog/digital output	1
Current/voltage range	0/4 – 20 mA / 24 V DC
Relay output	
Programmable relay output	1
Max. terminal load	250 V AC, 2 A, 500 VA
Fieldbus communication	
FC Protocol, Modbus RTU	Built-in
Profibus DP	Optional (integrated)
Externals	
Vibration test	1.0 g (IEC 60068)
Max. relative humidity	95% (IEC 60068-2-3)
Ambient temperature	Max. 40° C (24 hour average max. 35° C)
Min. ambient temperature in full operation	0° C
Min. ambient temperature at reduced performance	-10° C

Technical data

FCM	305	307	311	315	322	330	340	355	375
Motor output									
[HP]	0.75	1.0	1.5	2.0	3.0	4.0	5.0	7.5	10.0
[kW]	0.55	0.75	1.1	1.5	2.2	3.0	4.0	5.5	7.5
Motor torque									
2-pole [Nm] 1)	1.8	2.4	3.5	4.8	7.0	9.5	12.6	17.5	24.0
4-pole [Nm] 2)	3.5	4.8	7.0	9.6	14.0	19.1	25.4	35.0	48.0
Frame size									
[mm]	80	80	90	90	100	100	112	132	132
Input current [A] 380 V									
2-pole	1.5	1.8	2.3	3.4	4.5	5.0	8.0	12.0	15.0
4-pole	1.4	1.7	2.5	3.3	4.7	6.4	8.0	11.0	15.5
Input current [A] 480 V									
2-pole	1.2	1.4	1.8	2.7	3.6	4.0	6.3	9.5	11.9
4-pole	1.1	1.3	2.0	2.6	3.7	5.1	6.3	8.7	12.3

1) at 400 V, 3000 RPM, 2) at 400 V, 1500 RPM

VLT® OneGearDrive®



VLT® OneGearDrive® Hygienic



VLT® OneGearDrive® Standard with brake

Up to 89%

system efficiency

can be achieved with VLT® OneGearDrive® together with VLT® AutomationDrive FC 302 or VLT® Decentral Drive FCD 302. Exceed the IE4 Super Premium Efficiency class today.

VLT® OneGearDrive® is a highly efficient permanent-magnet three-phase synchronous motor coupled to an optimised bevel gear box. As part of the Danfoss VLT® FlexConcept® the VLT® OneGearDrive® is an energy-efficient drive system that helps to optimise plant productivity and reduce energy costs.

With only one motor type and three available gear ratios, the motor concept covers all typical versions of conveyor drives commonly used in the food and beverage industry. Furthermore, the restricted range of physical configurations of the VLT® OneGearDrive® simplifies spares holding and makes it more cost efficient, easing engineering and installation thanks to uniform mechanical dimensions.

Flexible plant design

In combination with the VLT® AutomationDrive FC 302 or the VLT® Decentral Drive FCD 302 the VLT® OneGearDrive® is equally suited to central and decentral installations, giving the plant designer complete flexibility from the outset. As a whole, the system can reach energy savings of up to 40% compared with conventional systems.

Two versions

The VLT® OneGearDrive® comes in two versions, the VLT® OneGearDrive® Standard for use in dry and wet production areas and the VLT® OneGearDrive® Hygienic for use in wet areas, areas with high cleaning intensity and aseptic and clean room production areas.

Feature	Benefit
High system efficiency incl. frequency converter	Save money and energy – up to 40% energy savings compared to conventional systems
High-efficiency Permanent-magnet three-phase synchronous 10-pole motor with bevel gear drive	Better than Super Premium Efficiency class IE4
Available hollow shaft diameters: 30, 35, 40 mm and 3 imperial shaft sizes	Flexible adaption to customer standards
Completely smooth enclosure leaves no crevices or dirt traps	– Easy to clean – Safe production
Motor connection with Danfoss CleanConnect® stainless steel circular connector	– Safe connection in wet areas – Fast installation and replacement – High cleanability
Motor and brake connections via terminal box with CageClamp® technology	– Fast, reliable connection – Lower installation cost
Aseptic coating	– Resistant to detergents and disinfectants (pH 2..12)
Gearbox without breather vents and use of food grade lubricants compliant with FDA and NSF requirements	Up to 35,000 operating hours in partial loa between oil change
High degrees of protection: – IP 67 and IP 69K (OGD- H) – IP 65 and IP 67 (OGD- S)	– Unrestricted use in wash down areas – High protection in wash down areas
Fan-free operation	– Less noise emission – No air-born germs and dirt particles to be drawn into the motor and then expelled back into the surrounding air
Only 3 gearbox ratios in one common design	Up to 70% reduction in variants reduces spare part stock
Compatible with all Danfoss frequency converters FC/D 302 from 1.5-3 kW	Free choice of central and decentral instalations

In both versions, completely smooth, easy to clean surface without cooling fins, prevents pockets of dirt from forming and allows detergents to drain off freely. The fan-free motor avoids the risk of air-borne germs and dirt particles being drawn in and then expelled back into the surrounding air.

Hygienic design

The VLT® OneGearDrive® Hygienic complies with the requirements for best cleaning and hygienic design – with certification according to EHEDG (European Hygienic Engineering & Design Group). It is certified as usable for clean rooms and aseptic filling by IPA (Fraunhofer institute) according to the dedicated “Air Cleanliness Classification” DIN EN ISO 14644-1.



Specifications

Power rating 1.5 – 3.0 kW
 Speed max 3000 rpm
 Frequency max 250 Hz
 Current max 7.2 A
 Torque 1.7 Nm/A
 Voltage 120 V/1000 rpm
 Weight Approx. 28 kg

Speed/ torque characteristics for gear ratios $i = 31.13$; $i = 14.13$ and $i = 5.92$ (max 3.0 kW)

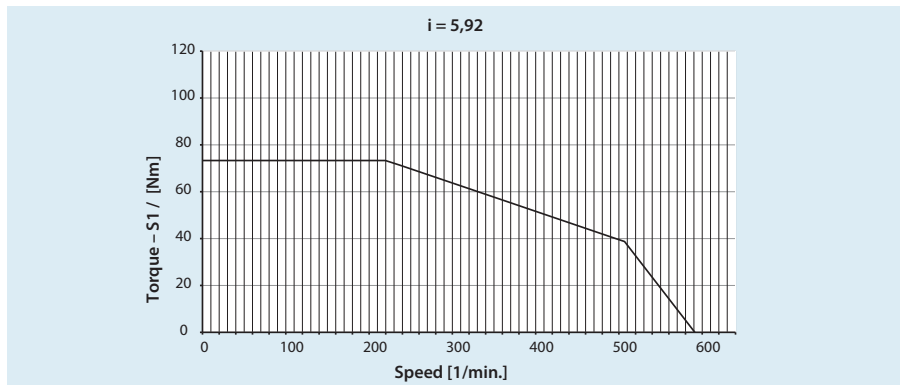
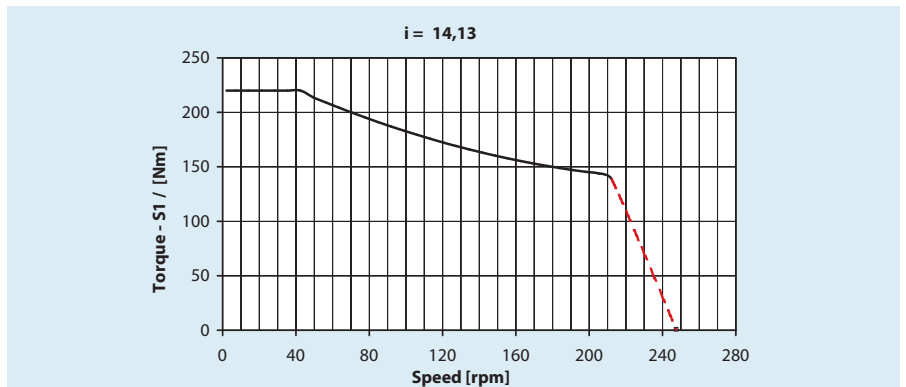
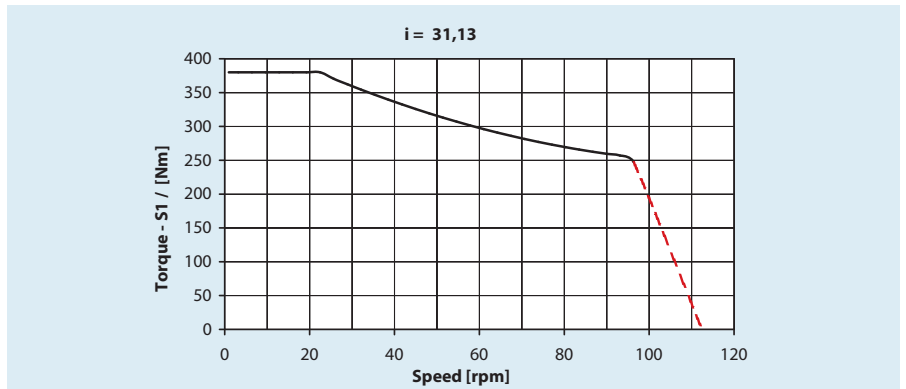

Dimensions

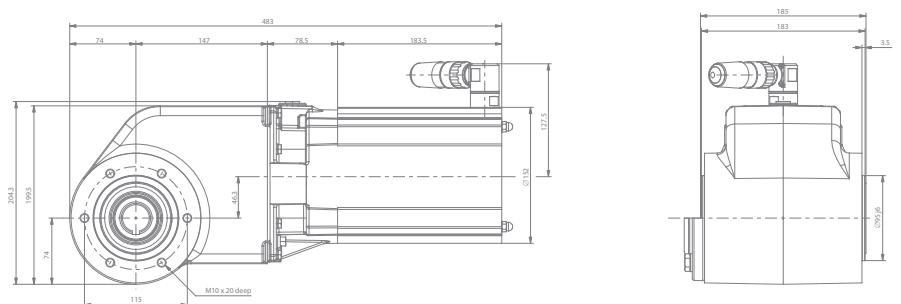

Dimensions of Danfoss VLT® OneGearDrive® Hygienic in mm

VLT® Integrated Servo Drive System ISD 410



The integration of servomotor and electronic drive unit in the same housing makes this drive system predestined for applications requiring high flexibility and dynamics, such as those in the food & beverage and packaging industries. The decentralisation of the drive unit offers benefits in mounting, installation and operation. Depending on the application, up to 60 drives can be integrated into the servo drive system.

Servo Drive

The motion control is integrated into the drive so that the motion sequences can take place independently. This releases the higher-ranking controller and offers a highly flexible drive concept. The master can be programmed via IEC 61131-3 and hybrid cables are used to connect the drives, making installation fast and simple.

Feature	Benefit
Compact and decentral servo drive	Reduced costs and high flexibility
Dynamic servo performance	Fast, accurate and energy-efficient
System setup performance	Simple and fast configuration of several drives
DC supply to drives from a central power supply module	Fast installation, reduced number of cables
Control via IEC 61131-3	Open system
Hybrid cable	Easy and fast installation, reduced number of cables
All components support CAN	Enhanced diagnostics, reduced downtime

Power Supply Module

The system is powered with DC 300 V via the power supply module. LEDs on the front of the unit enable easy monitoring of operating status. The maximum current output is 10 A and nominal power is 3 kW.

Connection Box

The connection box creates the link between the servomotors and the power supply. Two independent groups of up to 30 motors can be connected. The hybrid cable contains the DC supply, CAN and safety.

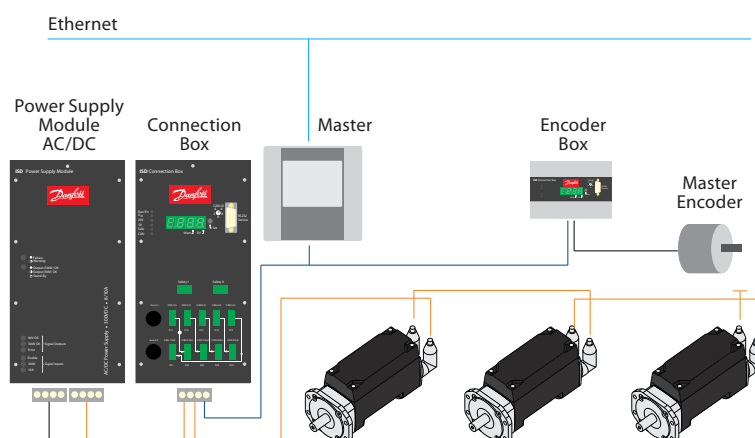

Encoder Box

The encoder box enables a master encoder to be connected, this to be read with high precision, and time information to be sent to the drives via CAN. If no encoders are connected, the encoder box functions as a virtual axis for the ISD 410 servo drive system.

Available Options

- Safe Torque Off (STO)
- Brake
- Feedback:
 - Resolver
 - Singleturn
 - Multiturn
- Flexible hybrid loop cable
- IEC flange
- Customised flange on request

Available Accessories

- Shaft seal
- Connector kits for:
 - Power Supply Module
 - Connection Box
 - Encoder Box
- Terminating resistor

Specifications

Servomotor	
Rated voltage	DC 300 V
Rated torque	1.7-2.1 Nm
Max. torque	8-11 Nm
Rated current	0.6-1.15 A
Max. current	3.95-7.05 A
Rated speed	600-1000 rpm
Max. speed	1000-1500 rpm
Rated power	180-345 W
Inertia	$3.5 \cdot 10^{-4}$ to $6.5 \cdot 10^{-4}$ kgm ²
Shaft diameter	19 mm
Enclosure	IP 54/IP 65
Power Supply Module	
Input voltage	AC 380-480 V $\pm 10\%$, 3-phase: L1, L2, L3, PE
Input current	6 A _{rms} each phase
Output voltage	DC 300 V
Rated power	3000 W
Rated current	10 A
Dimensions (H x W x D)	268 x 130 x 205 mm
Connection Box	
Input voltage	DC 300 V
Output voltage lines 1 & 2	DC 300 V
Rated power	3000 W
Rated current	10 A
Dimensions (H x W x D)	268 x 130 x 205 mm
Encoder Box	
Input voltage	DC 24 V
Supported encoder inputs	SSI, SSI-CRC, QEP, BiSS
Dimensions (H x W x D)	105.2 x 142.0 x 70.8 mm

Dimensions

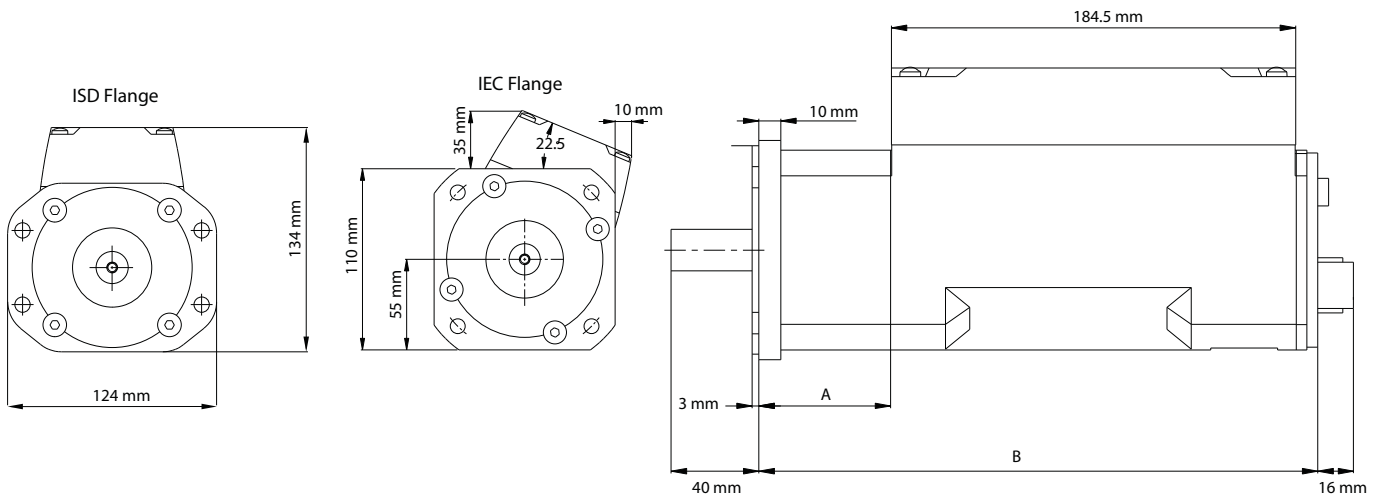

Motor ISD 410	Dimensions [mm]	
	A	B
ISD / IEC flange with brake	60	255
ISD / IEC flange without brake	35	230

VLT® Soft Starter MCD 500



VLT® Soft Starter MCD 500 is a total motor starting solution. Current transformers measure motor current and provide feedback for controlled motor ramp profiles.

AAC, Adaptive Acceleration Control, automatically employs the best starting and stopping profile for the application.

Adaptive Acceleration Control means, that for each start and stop, the soft starter compares and adapts the process to the chosen profile fitting to the application.

VLT® Soft Starter MCD 500 has a four line graphical display and a logic keypad making programming easy. Advanced setup is possible displaying operational status.

Three menu systems: Quick Menu, Application Setup and Main Menu provide optimum programming approach.

Power range

21 – 1600 A, 7.5 – 850 kW
(1.2 MW inside Delta Connection)
Versions for 200 – 690 VAC

Feature	Benefit
AAC Adaptive Acceleration Control	Automatically adapts to the chosen starting and stopping profile
Adjustable bus bars allow for both top and bottom entry (360–1600 A, 160–850 kW)	Space saving, less cable cost and easy retrofitting
DC injection braking distributed evenly over three phases	Less installation cost and less stress on the motor
Inside Delta (6-wire connection)	Smaller soft starter can be selected for the application
Log menus, 99 events and trip log provide information on events, trips and performance	Eases analysis of the application
Auto Reset	Less down-time
Jog (slow-speed operation)	Application flexibility
Second-order thermal model	Allows motors to be used to their full potential without damage from overloading
Internal bypass contactors (21–215 A, 7.5–110kW)	<ul style="list-style-type: none"> – Saves space and wiring compared to external bypass – Very little heat dissipates when running. Eliminates costly external fans, wiring or bypass contactors
Auto-start/stop clock	Application flexibility
Compact size – amongst the smallest in their class	Saves space in cabinets and other application setups
4-line graphical display	Optimum programming approach and setup for viewing operational status
Multiple programming setup (Standard Menu, Extended Menu, Quick Set)	Simplifies the programming, but still holding to maximum flexibility
Multiple languages	Serving the whole world

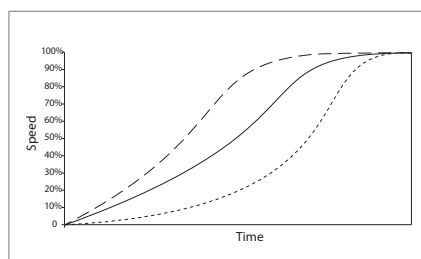

Three Adaptive Acceleration Control (AAC) start profiles; early, constant and late acceleration

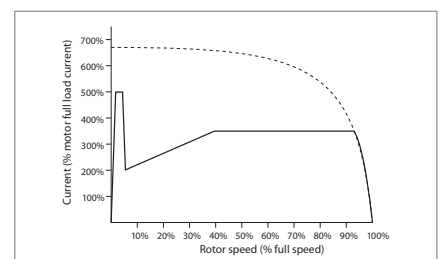

Constant current/ current ramp – here shown with kickstart

Fully featured Soft Starter for motors up to 850 kW

- Total motor starting solution
- Advanced start, stop and protection features
- Adaptive Acceleration Control
- Inside Delta connection
- 4-line graphical display
- Multiple programming setup menus

Optional

- Modules for serial communication:
 - DeviceNet
 - PROFIBUS
 - Modbus RTU
 - PROFINET
 - Modbus TCP
 - EtherNet IP
- Remote operator kit
- PC software:
 - WinMaster
 - USB
 - VLT® Motion Control Tool MCT10



VLT® Control Panel LCP 501

- A full function HMI interface
 - everything you can do on the VLT® Soft Starter MCD 500 is possible via the LCP 501
- Danfoss “FC” menu structure and button interface concept
- Multiple language selection
 - incl. Russian and Chinese
- Full graphics
- Real language in 4 lines
- Full parameter list, Quick Menu and application setup
- Adjustable multiple monitoring views
- A “copy-paste” function allows the user to copy parameter settings in the LCP and load to other unit.
- IP 65, NEMA3R
- 3 m cable and mounting kit included

Specifications

Mains voltage (L1, L2, L3)	
MCD5-xxxx-T5	200 VAC ~ 525 VAC (± 10%)
MCD5-xxxx-T7	380 VAC ~ 690 VAC (± 10%)
MCD5-xxxx-T7	380 VAC ~ 600 VAC (± 10%) (inside delta connection)
Control voltage (terminals A4, A5, A6)	
CV1 (A5, A6)	24 VAC/VDC (± 20%)
CV2 (A5, A6)	110~120 VAC (+ 10% / - 15%)
CV2 (A4, A6)	220~240 VAC (+ 10% / - 15%)
Mains frequency	50/60 Hz (± 10%)
Rated insulation voltage to earth	600 VAC
Rated impulse withstand voltage	4 kV
Form designation	Bypassed or continuous, semiconductor motor starter form 1
Short circuit capability	
Coordination with semiconductor fuses	Type 2
Coordination with HRC fuses	Type 1
MCD500-0021B to 0215B	Prospective current of 65 kA
MCD500-0245C	Prospective current of 85 kA
MCD500-1200C to 1600C	Prospective current of 100 kA
Electromagnetic capability (compliant with EU Directive 89/336/EEC)	
EMC Emissions (Terminals 13 & 14)	IEC 60947-4-2 Class B and Lloyds Marine No. 1 Specification
EMC Immunity	IEC 60947-4-2
Outputs	
Relay Outputs	10A @ 250 VAC resistive, 5A @ 250 VAC AC15 pf 0.3
Programmable Outputs	
Relay A (13, 14)	Normally open
Relay B (21, 22, 24)	Changeover
Relay C (33, 34)	Normally open
Analogue Output (07, 08)	0 – 20 mA or 4 – 20 mA (selectable)
Maximum load	600 Ω (12 VDC @ 20 mA) (accuracy ± 5%)
24 VDC Output (16, 08) Maximum load	200 mA (accuracy ± 10%)
Environmental	
Protection MCD5-0021B ~ MCD5-0105B	IP 20 & NEMA, UL Indoor Type 1
Protection MCD5-0131B ~ MCD5-1600C	IP 00, UL Indoor Open Type
Operating temperature	-10° C to 60° C, above 40° C with derating
Storage temperature	-25° C to + 60° C
Operating Altitude	0 – 1000 m, above 1000 m with derating
Humidity	5% to 95% Relative Humidity
Pollution degree	Pollution Degree 3
Heat Dissipation	
During start	4.5 watts per ampere
During run (approx.)	MCD5-0021B - MCD5-0053B = 39 watts MCD5-0068B - MCD5-0105B = 51 watts MCD5-0131B - MCD5-0215B = 120 watts
	MCD5-0245C - MCD5-0927C 4.5 watts per ampere MCD5-1200C - MCD5-1600C 4.5 watts per ampere

Dimensions

Current rating [A]	Weight [kg]	Height [mm]	Width [mm]	Depth [mm]	Frame size
21, 37, 43 and 53	4.2	295	156	192	G1B
68	4.5			223	
84, 89 and 105	4.9				
131	14	438	282	250	G2B
141	14.2				
195 and 215	15				
245	26	440	424	298	G3B
331 and 396	29.4				
469 and 525	49				
632 and 744	62.5	640	433	297	G4B
826 and 961	63				
245	23			417	
360, 380 and 428	36	698	430	302	G4C
595, 619 and 790	39				
927	51				
1200	128.5	750	574	361	G5C
1410	130				
1600	140				

VLT® Compact Starter MCD 200



The VLT® Compact Starter MCD 200 from Danfoss includes two families of soft starters in the power range from 7.5 to 110 kW.

The series offer easy DIN rail mounting for sizes up to 30 kW, 2-wire or 3-wire start/stop control and excellent starting duty ($4 \times I_e$ for 6 seconds).

Heavy starting ratings at $4 \times I_e$ for 20 seconds.

Compatible with grounded delta power systems.

Power range
7.5 – 110 kW

Feature	Benefit
Small footprint and compact size	Saves panel space
Built-in bypass	<ul style="list-style-type: none"> Minimises installation cost and eliminates power loss Reduces heat build up. Savings in components, cooling, wiring and labor
Advanced accessories	Allows enhanced functionality
Advanced SCR Control Algorithms balances output waveform	Allowing more starts per hour, accepting higher load
User friendly	Save commissioning and operating cost
Easy to install and use	Saves time
Easy DIN rail mounting for sizes up to 30 kW	Saves time and space
Reliable	Maximum uptime
Essential motor protections (MCD 202)	Reduces overall project investment
Max. ambient temperature 40° C without derating	No external cooling or oversizing necessary

MCD 201

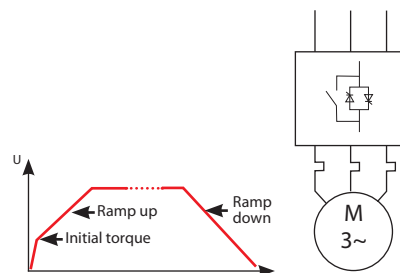

MCD 202

MCD 202 provides enhanced soft start functionality and various motor protection features

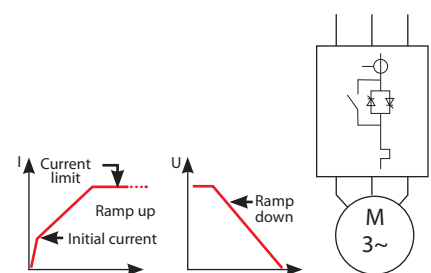

Soft Starter for motors up to 110 kW

- Total motor starting solution
- Start, stop and protection features
- Local programming keypad and display

Optional

- Modules for serial communication:
 - DeviceNet
 - PROFIBUS
 - Modbus RTU
 - PROFINET
 - Modbus TCP
 - EtherNet IP
- Remote operator kit
- PC software
 - WinMaster
 - USB



Remote operation kit

Remote Operator and display with 4–20 mA analogue output proportional to motor current (MCD 202)
 Serial communication: Modbus/485, ASCII. PC-based MCD set-up software.

Specifications

Mains supply (I1, L2, L3)	
Supply voltage	3 x 200 VAC – 440 VAC or 3 x 200 – 575 VAC
Supply frequency	45 – 66 Hz
Control voltage	110 – 240 VAC 380 – 440 VAC 24 VDC/24 VAC
Control inputs	
Control inputs	Start, Stop Reset push button on the unit
Relay outputs	
Relay outputs	1 x main contactor 1 x programmable (Trip or Run) (MCD 202 only)
Protections, MCD 201	
	Supply fault
Protections, MCD 202	
	Power Circuit (SCRs and Supply fault) Excess Start Time Motor Overload - Thermal model Motor thermistor Phase imbalance Supply Frequency Phase rotation - sequence Network Coms Starter Com Bypass Overload
LED indications	
Indications	Ready/Fault Run
Ambient operating temperature	
Ambient temperature	-10 to 60°C (above 40°C without derating)
Standards approvals	
Approvals	CE, UL, C-UL, CCC, C-tick, Lloyds

Cabinet sizes

Power range (400 V)	7 – 30 kW	37 – 55 kW	75 – 110 kW
Height [mm]	203	215	240
Width [mm]	98	145	202
Depth [mm]	165	193	214

VLT® Soft Start Controller MCD 100



VLT® Soft Start Controller MCD 100 is a cost effective and extremely compact soft starter for AC motors.

A true “fit and forget” soft starter for DIN rail mount, VLT® Soft Start Controller MCD 100 provides basic soft start and stop function.

- A robust semiconductor design
 - selection can be based on motor power which ensures easy selection.
- Can be used for an almost unlimited number of starts per hour without derating.
- A universal control voltage (24-480 V AC/V DC) – simplifies selection and keeps stock at a minimum.
- A “fit and forget” contactor design
 - simplifies installation and reduces required panel space.
- Digitally controlled rotary switches
 - secures precise settings and simplifies installation.
- Ratings for heavy duty as standard
 - simplifies installation and reduces the risk of breakdown

Feature	Benefit
Small footprint and compact size	Saves panel space
Selection can be based on motor power	Easy selection
Universal control voltage	<ul style="list-style-type: none"> – Simplifies selection – Keeps stock at a minimum
“Fit and forget” contactor design	<ul style="list-style-type: none"> – Simplifies installation – Reduces required panel space
User friendly	Save commissioning and operating cost
Easy to install and use	Saves time
Digitally controlled rotary switches	Secures precise settings and simplifies installation
Easy DIN rail mounting for sizes up to 30 kW	Saves time and space
Reliable	Maximum uptime
Robust semiconductor design	Reliable operation
Almost unlimited number of starts per hour without derating	Prevents unauthorized changes
Max. ambient temperature 50° C without derating	No external cooling or oversizing necessary

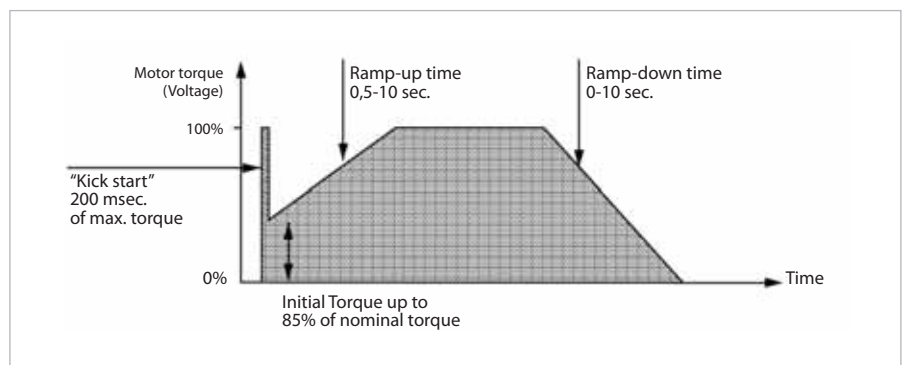

Timed voltage ramp

- Micro Soft Start Controller for motors up to 11 kW
- Extremely robust SCR design with heavy ratings as standard
- Unlimited number of starts per hour
- Contactor style design for easy selection, installation and commissioning

Power range

MCD 100-001	1,5 kW
MCD 100-007	7.5 kW
MCD 100-011	11 kW

All sizes are rated for line voltage up to 600 V AC.

Specifications

Mains supply (L1, L2, L3)	
MCD 100	3 x 208 VAC ~ 600 VAC (+10% / -15%)
Supply frequency (at start)	45 Hz – 66 Hz
Control circuit (A1, A2)	
MCD 100	24 – 480 VAC/VDC (-15% +10%)
Environmental	
Degree of protection MCD 100	IP 20
Operating temperatures	-5° C/+40° C (60° C with de-rating)
Pollution Degree	Pollution Degree 3
EMC Emission	
Equipment class (EMC)	Class A
Conducted radio frequency emission	
0.15 MHz – 0.5 MHz	< 90 dB (µV)
0.5 MHz – 5 MHz	< 76 dB (µV)
5 MHz – 30 MHz	80-60 dB (µV)
Radiated radio frequency emission	
30 MHz – 230 MHz	< 30 dB (µV/m)
230 MHz – 1000 MHz	< 37 dB (µV/m)

This product has been designed for Class A equipment. Use of the product in domestic environments may cause radio interference, in which case the user may be required to employ additional mitigation methods.

EMC Immunity	
Electro static discharge	4 kV contact discharge, 8 kV air discharge
Radio-frequency electromagnetic field	
0.15 MHz – 1000 MHz	140 dB (µV)
Rated impulse withstand voltage (Fast transients 5/50 ns – Burst)	4 kV line to earth
Rated insulation voltage (Surges 1.2/50 µs – 8/20 µs)	4 kV line to earth, 2 kV line to line
Voltage dip and short time interruption	100 ms (at 40% nominal voltage)
Short Circuit	
Rated short-circuit current MCD 100-001	Normal fuses: 25 A gL/gG
SCR I2t rating for semiconductor fuses	72 A2s
Rated short-circuit current MCD 100-007	Normal fuses: 50 A gL/gG
SCR I2t rating for semiconductor fuses	1800 A2s
Rated short-circuit current MCD 100-011	Normal fuses: 80 A gL/gG
SCR I2t rating for semiconductor fuses	6300 A2s
Heat Dissipation	
MCD 100-001	Max. 4 watts
MCD 100-007 to MCD 100-011	2 watts/Ampere
Standards Approvals	
UL/C-UL	UL508
CE	IEC 60947-4-2

Dimensions

Model	Power size (kW)	Rated current (Amps)	Dimensions (mm) H x W x D	Approvals
MCD 100	1.5	3 A: 5-5:10 (AC 53b)	102x22,5x124	UL, CSA, CE
	7.5	15 A: 8-3: 100-3000 (AC 53a)	110x45x128	
	11	25 A: 6-5:100-480 (AC 53a)	110x90x128	

VLT® Low Harmonic Drive

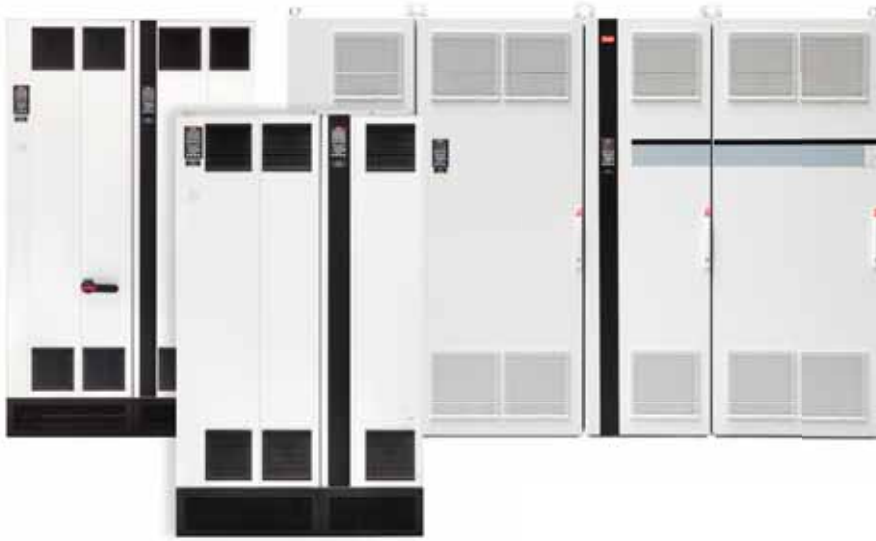

The Danfoss VLT® Low Harmonic Drive is the first solution combining an active filter and a drive in one package.

The VLT® Low harmonic drive continuously regulates harmonic suppression according to the load and grid conditions without affecting the connected motor.

The total harmonic current distortion is reduced to less than 3% on grids with balanced mains, a minimum pre-distortion to less than 5% on grids with high harmonic distortion and 2% phase unbalance. As individual harmonics also fulfil toughest harmonic requirements, the VLT® Low harmonic drive meets all present harmonic standards and recommendations.

Unique features such as sleep mode and back channel cooling offers unmatched energy efficiency for Low Harmonic Drives.

The VLT® Low harmonic drive requires the same set-up and installation as a standard VLT® drive and out of the box it ensures optimum harmonic performance.

The VLT® Low harmonic drive has the same modular build-up as our standard high power drives and shares similar features: Built-in RFI filters, coated PCB and user-friendly programming.

Feature	Benefit
Reliable	Maximum uptime
No increased winding stress on motor	– Longer motor lifetime – Less initial cost (no output filter needed)
– 100% factory tested – Coated PCBs	Low failure rate
Innovative cooling concept	Prolonged lifetime of electronics
User-friendly	Saves commissioning and operating cost
No extra wiring and set-up needed	Easy commissioning and low initial costs
Modular design	Easy serviceability
Full readout of grid conditions	Reduces needed harmonic testing
Energy saving	Lower operation costs
– High efficiency – Sleep mode and progressive switching freq.	Low running expenses
Independent of grid and load changes	– Increased transformer efficiency – Reduced cable losses

Voltage range

- 380 – 480 V AC 50 – 60 Hz

Power Range

- **High overload:**
132-630 kW
200-900 hp
- **Normal overload:**
160-710 kW
250-1000 hp

Enclosure degree

- IP 21/NEMA 1
- IP 54/NEMA 12

Options

The following options are available:

- RFI filters
- Disconnect
- Fuses
- Mains shielding
- Feedback and I/O options
- Fieldbus options
- dU/dt filters
- Sine wave filters

PC software

VLT® Motion Control Tool MCT 10 offers advanced programming functionality for all Danfoss drive products, greatly reducing programming and set-up time.

MCT 10 Basic (available free of charge from www.danfoss.com) allows access to a finite number of drives with limited functionality. The advanced edition, offering a higher level of functionality, is available from your Danfoss sales partner.

Calculation Software

With VLT® Motion Control Tool MCT 31, you can determine whether harmonics will be an issue in your installation when drives are added.

MCT 31 estimates the benefits of adding various harmonic mitigation solutions from the Danfoss product portfolio and calculates system harmonic distortion. Furthermore the software provides quick indication of whether the installation complies with the most recognised harmonic norms and recommendations.

From www.danfoss.com you can download the free tool MCT 31 – the most up-to-date version of the calculation software.

Specifications

THiD* at:	
– 40% load	< 5,5%
– 70% load	< 3,5%
– 100% load	< 3%
Efficiency* at:	
– 40% load	> 93%
– 70% load	> 95%
– 100% load	> 96%
True power factor* at:	
– 40% load	> 98%
– 70% load	> 98%
– 100% load	> 98%
Ambient temperature	50° C without derating (D-frame 45° C)
Cooling	Back-channel air cooling

* Measured at balanced grid without pre-distortion

Norms and recommendations	Compliance
IEEE519	Always
IEC61000-3-2 (up to 16 A)	Out of scope
IEC61000-3-12 (between 16 and 75 A)	Out of scope
IEC61000-3-4 (above 75 A)	Always

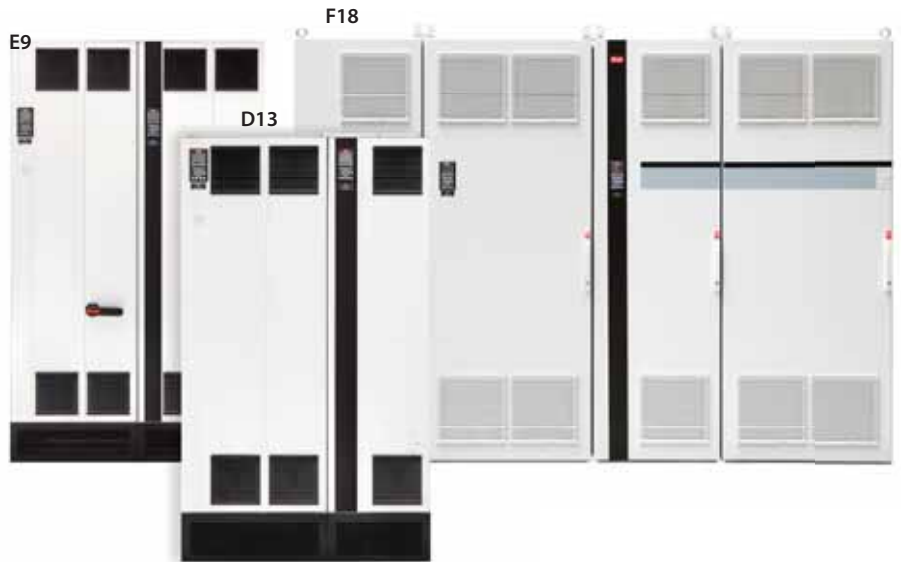

400 VAC (380 – 460 VAC)									
Normal Overload			High Overload			Frame	Dimensions H x W x D IP 21/54	Weight	
Power kW	HP	Current [A]	Power kW	HP	Current [A]			kg	lbs
160	250	315	132	200	260	D13	1780 x 1020 x 380 mm 70 x 40 x 15 inches	390	860
200	300	395	160	250	315			390	860
250	350	480	200	300	395			390	860
315	450	600	250	350	480	E9	2000 x 1200 x 500 mm 79 x 47 x 19 inches	676	1491
355	500	658	315	450	600			676	1491
400	625	745	355	500	658			676	1491
450	700	800	400	625	695			676	1491
500	780	880	450	700	800			1899	4187
560	875	990	500	780	880	F18	2277 x 2800 x 600 mm 90 x 110 x 24 inches	1899	4187
630	985	1120	560	875	990			1899	4187
710	1100	1260	630	985	1120			1899	4187

12-pulse VLT® drive

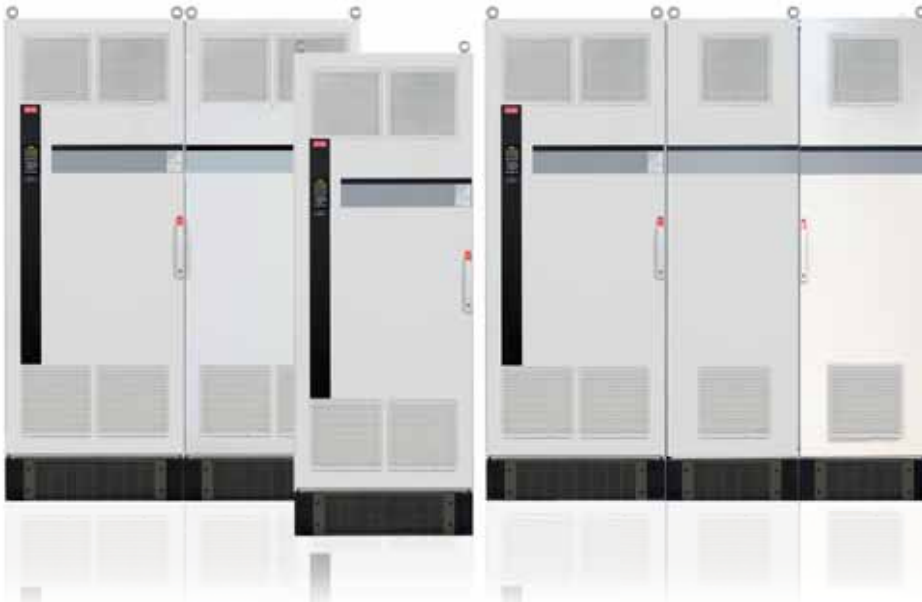

Robust and cost effective harmonic solution for the higher power range. The Danfoss 12-pulse VLT® drive offers reduced harmonics for demanding industry applications above 250 kW.

The 12-pulse VLT® drive is a high efficiency variable frequency converter which is built with the same modular design as the popular 6-pulse VLT® drives. It is offered with similar drive options and accessories and can be configured according to customer need.

Together with the needed 30°-phase shifting transformer the solution provides durability and reliability at a low cost.

Under ideal grid conditions the solution eliminates the 5th, 7th, 17th and 19th harmonics and results in a THiD of around 12% at full load.

The needed transformer makes this solution ideal for applications where stepping down from medium voltage is required or where isolation from the grid is needed.

The Danfoss 12-pulse VLT® drive provides harmonic reduction without adding capacitive or inductive components which often require network analysis to avoid potential system resonance problems.

Feature	Benefit
Reliable	Maximum uptime
Maintenance free	No running expenses
Durability	Long lifetime
Coated PCBs	Environmental robustness
100% factory tested	Low failure rate
Backchannel cooling	Prolonged lifetime of electronics
Design	Easy operation and user-friendly set-up
Modular design	Easy serviceability
Same easy programming as a 6-pulse drive	User-friendly operation
– Standard award-winning control panel (LCP)	Effective commissioning and operation
– Available in 27 languages	

Power Range

- 250 kW – 1.4 MW

Voltage Range

- 380 – 690 V

Enclosure

- IP 21/NEMA Type 1
- IP 54/NEMA Type 12

Options

The following options are available:

- RFI filters
- Disconnect
- Fuses
- Mains shielding
- Feedback and I/O options
- Fieldbus options
- dU/dt filters
- Sine wave filters

PC software

VLT® Motion Control Tool MCT 10 offers advanced programming functionality for all Danfoss drive products, greatly reducing programming and set-up time.

MCT 10 Basic (available free of charge on www.danfoss.com) allows access to a finite number of drives with limited functionality. The advanced edition, offering a higher level of functionality, is available from your Danfoss sales partner.

Calculation Software

With VLT® Motion Control Tool MCT 31 you can determine whether harmonics will be an issue in your installation when drives are added.

MCT 31 estimates the benefits of adding various harmonic mitigation solutions from the Danfoss product portfolio and calculates system harmonic distortion.

From www.danfoss.com you can download the free tool MCT 31.

Specifications

THiD* at:	
- 40% load	20%
- 70% load	14%
- 100% load	12%
Efficiency* at:	
- 40% load	95%
- 70% load	97%
- 100% load	98%
True power factor* at:	
- 40% load	91%
- 70% load	95%
- 100% load	97%
Ambient temperature	45° C without derating
Cooling	Back-channel air cooling

* Measured at balanced grid without pre-distortion

Norms and recommendations	Compliance
IEEE519	Depends on grid and load conditions
IEC61000-3-2 (up to 16 A)	Out of scope
IEC61000-3-12 (between 16 and 75 A)	Out of scope
IEC61000-3-4 (above 75 A)	Always

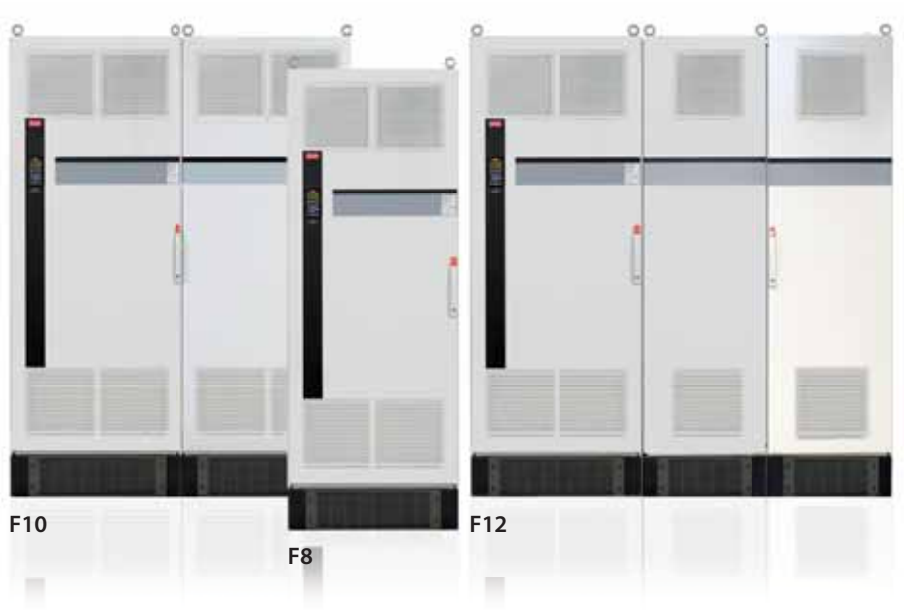

400 V AC				460 V AC				690 V AC				Frame dimensions	
Normal		High		Normal		High		Normal		High		Without options cabinet H x W x D IP 21 [mm]	With options cabinet H x W x D IP 21 [mm]
Power [kW]	Current [A]	Power [kW]	Current [A]	Power [HP]	Current [A]	Power [HP]	Current [A]	Power [kW]	Current [A]	Power [kW]	Current [A]		
315	600	250	480	450	540	350	443	450	450	355	380	F8 2280 x 800 x 607	F9 2280 x 1400 x 607
355	658	315	600	500	590	450	540	500	500	400	410		
400	745	355	658	600	678	500	590	560	570	500	500		
450	800	400	695	600	730	550	678	630	630	560	570		
500	880	450	800	650	780	600	730	710	730	630	630	F10 2280 x 1600 x 607	F11 2280 x 2400 x 607
560	990	500	880	750	890	650	780	800	850	710	730		
630	1120	560	990	900	1050	750	890	900	945	800	850		
710	1260	630	1120	1000	1160	900	1050						
800	1460	710	1260	1200	1380	1000	1160	1000	1060	900	945	F12 2280 x 2000 x 607	F13 2280 x 2800 x 607
1000	1720	800	1460	1350	1530	1200	1380	1200	1260	1000	1160		
								1400	1415	1200	1260		

VLT® Advanced Active Filter AAF 006



A flexible and adaptable solution for central or decentral harmonic mitigation.

VLT® Advanced Active Filter AAF 006 can compensate for individual VLT® drives or can be installed as a compact stand-alone solution at a common point of coupling, compensating for several loads simultaneously.

Consequently the filter ensures optimal harmonic suppression independent of the number of loads and their individual load profile. In addition the active filter corrects the power factor and balances the phase load providing an optimal energy utilization.

This improves the system efficiency and increases the grid robustness to avoid downtime.

The extensive re-use of proven VLT® components and the modular construction ensures a high reliability and at the same time offers high energy efficiency, back channel cooling and high enclosure grades without size increase.

The VLT® Advanced Active Filter is easily controlled via the user-friendly LCP, sharing design and programming structure with the VLT® drives series.

Feature	Benefit
Reliable	Maximum uptime
<ul style="list-style-type: none"> – 100% factory tested – Coated PCBs – >90% components re-used from proven VLT® FC series 	Low failure rate
Innovative cooling concept	Prolonged lifetime of electronics
User-friendly and flexible	Saves commissioning and operating cost
Innovative programming possibilities	Low running expenses
Modular design	Easy serviceability
Wide range of options	<ul style="list-style-type: none"> – Low initial investment – High degree of customisation
Energy saving	Lower operation costs
<ul style="list-style-type: none"> – High efficiency – Sleep mode and progressive switching freq. – Power factor correction 	Low running expenses

Without dismantling existing installation, the VLT® Advanced Active Filters are easily retrofitted to the existing installation, where harmonics are increased because of enlarged employment of non-linear loads such as variable speed drives.

Voltage range
380 – 480 V AC 50 – 60 Hz

Current range
190 A, 250 A, 310 A, 400 A.
Up to 4 units can be paralleled for higher power.

Enclosure degree
■ IP 21/NEMA Type 1
■ IP 54/NEMA Type 12

Options

The following options are available:

- RFI filters
- Disconnect
- Fuses
- Mains shielding

PC software

VLT® Motion Control Tool MCT 10 offers advanced programming functionality for all Danfoss drive products, greatly reducing programming and set-up time.

MCT 10 Basic (available free of charge from www.danfoss.com) allows access to a finite number of drives with limited functionality.

The advanced edition, offering a higher level of functionality, is available from your Danfoss sales partner.

Calculation Software

With VLT® Motion Control Tool MCT 31, you can determine whether harmonics will be an issue in your installation when drives are added.

MCT 31 estimates the benefits of adding various harmonic mitigation solutions from the Danfoss product portfolio and calculates system harmonic distortion. Furthermore the software provides quick indication of whether the installation complies with the most recognised harmonic norms and recommendations.

From www.danfoss.com you can down-load the free tool MCT 31 – the most up-to-date version of the calculation software.

Specifications

THiD* at:	
- 40% load	< 7%
- 70% load	< 5.5%
- 100% load	< 5%
Efficiency* at:	
- 40% load	> 95%
- 70% load	> 98%
- 100% load	> 98%
True power factor* at:	
- 40% load	> 0.98
- 70% load	> 0.98
- 100% load	> 0.98
Ambient temperature	40° C without derating
Cooling	Back-channel air cooling

* Measured at balanced grid without pre-distortion and with VLT® drive matching full load demand

Norms and recommendations	Compliance
IEEE519	Application and load dependent
IEC61000-3-2 (up to 16 A)	Out of scope
IEC61000-3-12 (between 16 and 75 A)	Out of scope
IEC61000-3-4 (above 75 A)	Out of scope



400 V AC (380 – 480 V AC)					
Total Current [A]	Max. Reactive [A]	Max. Harmonic [A]	Frame	Dimensions H x W x D mm [Inches]	Weight Kg [Lbs]
190	190	170	D14	1780 x 600 x 380 [70 x 24 x 15.0]	238 [525]
250	250	225	E1	2000 x 600 x 500 [79 x 24 x 20]	429 [945]
310	310	280			453 [998]
400	400	360			

Total Current [A]	Max. individual harmonic compensation [A]							
	I ₅	I ₇	I ₁₁	I ₁₃	I ₁₇	I ₁₉	I ₂₃	I ₂₅
190	133	95	61	53	34	34	30	27
250	175	125	80	70	50	45	40	35
310	217	155	99	87	62	56	50	43
400	280	200	128	112	80	72	64	56

VLT® Advanced Harmonic Filter AHF 005/ 010



Optimised harmonic performance with the FC series up to 250 kW.

The VLT® Advanced Harmonic Filter AHF 005/ 010 have been specially designed to match the Danfoss frequency converters for unmatched performance and design.

Compared to traditional harmonic trap filters they offer a smaller foot print and higher harmonic reduction.

The solution is available in two variants, AHF 005 and AHF 010. When connected in front of a Danfoss VLT® frequency converter, the harmonic current distortion generated back to the mains is reduced to 5% and 10% Total Harmonic Current Distortion at full load.

With a >98% efficiency the passive Advanced Harmonic Filters offer cost effective and very robust harmonic solutions specifically for power up to 250 kW.

As stand-alone options the advanced harmonic filters feature a compact housing that is easily integrated into existing panel space. This makes them well-suited for retrofit applications with limited adjustments of the frequency converter.

Feature	Benefit
Reliable	Maximum uptime
<ul style="list-style-type: none"> – 100% factory tested – Based on proven and tested filter concept 	Low failure rate
Energy saving	Lower operation costs
<ul style="list-style-type: none"> – High efficiency – Electrically matched to the individual VLT® FC drives 	Low running expenses
Design	Compact and aesthetic enclosure
<ul style="list-style-type: none"> – Innovative coil design – Side-by-side mounting – Optimized for mounting in panels 	<ul style="list-style-type: none"> – Smaller footprint – Less wall space needed
Easy commissioning	Low commissioning costs
Enclosure size and colour matches	Danfoss look and feel

Line Voltage

- 380 – 415 V AC (50 and 60 Hz)
- 440 – 480 V AC (60 Hz)
- 600 V AC (60 Hz)
- 500 – 690 V AC (50 Hz)

Filter current

- 10A-480A (380-415V AC, 50 and 60 Hz)
- 10A-436A (440-480V AC, 60 Hz)
- 15A-395A, 600V AC, 60 Hz)
- 15A-395A (500-690V AC, 50 Hz)
- (Modules can be paralleled for higher power)

Enclosure degree

- IP 20/IP 00*

* Forced cooling is required. There are no fans in the IP00 units and the required air-flow must be implemented in the cabinet.

Options

The following options are available:

- IP 21/NEMA 1 kit
- IP 21/NEMA 1 kit with capacitor disconnect feature

Calculation Software

With VLT® Motion Control Tool MCT 31, you can determine whether harmonics will be an issue in your installation when drives are added.

MCT 31 estimates the benefits of adding various harmonic mitigation solutions from the Danfoss product portfolio and calculates system harmonic distortion. Furthermore the software provides quick indication of whether the installation complies with the most recognised harmonic norms and recommendations.

From www.danfoss.com you can down-load the free tool MCT 31 – the most up-to-date version of the calculation software.

Specifications

	AHF 010	AHF 005
THiD* at:		
– 40% load	~ 12%	~ 7%
– 70% load	~ 11%	~ 6%
– 100% load	< 10%	< 5%
Efficiency* at 100% load	>98.5%	
True power factor* at:		
– 40% load	~ 81%	~ 80%
– 70% load	~ 96%	~ 95%
– 100% load	> 99%	> 98%
Ambient temperature	45° C without derating	
Cooling	Back-channel air cooling	

* Measured at balanced grid without pre-distortion

Norms and recommendations	Compliance
IEEE519	AHF 005 always AHF 010 depends on grid and load conditions
IEC61000-3-2 (up to 16 A)	Always
IEC61000-3-12 (between 16 and 75 A)	Always
IEC61000-3-4 (above 75 A)	Always

Enclosures

AHF current rating [A]										Enclosure Type
380–415 V 50 Hz		380–415 V 60 Hz		440–480 V 60 Hz		600 V 60 Hz		500–690 V 50 Hz		
AHF005	AHF010	AHF005	AHF010	AHF005	AHF010	AHF005	AHF010	AHF005	AHF010	Type
10 14						-				X1
22 29		19 25		-		-				X2
34 40 55		31 36 48		-		15 20		-		X3
66 82		60 73		-		24 29 36		-		X4
96 133		95 118		-		50 58		-		X5
171 204		154 183		-		77 87 109 128		-		X6
251 304	251 304 325 381	251	251 304 325 381	231	231 291 355 380	155 197	155 197 240	155 197	155 197 240	X7
325 381 480	480	304 325 381 480	480	291 355 380 436	436	240 296	296 366 395	240 296	296 366 395	X8

Dimensions

Enclosure Type	Dimensions in mm		
	Height*	Width	Depth
X1	347	190	206
X2	451	230	248
X3	605	378	242
X4	634	378	333
X5	747	418	333
X6	778	418	400
X7	900	468	450
X8	900	468	515

* Maximum dimension. Actual dimension depends on fan concept. Please consult manual for actual dimension

VLT® Common Mode Filters MCC 105



VLT® Common Mode Filters MCC 105 core kit reduce electromagnetic interference and eliminate bearing damage by electrical discharge.

VLT® Common Mode Filters MCC 105 (HF-CM) cores are special nanocrystalline magnetic cores which have superior filtering performance compared to regular ferrite cores. They act like a common-mode inductor (between phases and ground).

Installed around the three motor phases (U, V, W), they reduce high-frequency common-mode currents. As a result, high-frequency electromagnetic interference from the motor cable is reduced. However, the core kit should not be used as the sole mitigation measure, and even when the cores are used, the EMC installation rules shall be followed.

Prevent motor bearing currents

The most important function is to reduce high-frequency currents associated with electrical discharges in the motor currents. These discharges contribute to the premature wear-out and failure of motor bearings. By reducing or even eliminating discharges, the wear-out of the bearings is reduced and the lifetime extended. Thus, maintenance and down-time costs are lowered.

Feature	Benefit
High-performance nanocrystalline magnetic material	<ul style="list-style-type: none"> – Effective reduction of electrical discharges in the motor bearings – Reduces bearing wear-out, maintenance costs and down-time – Reduces high-frequency electromagnetic interference from the motor cable
<ul style="list-style-type: none"> – Oval shape – Scalable solution: longer cables handled by stacking more cores 	Easy to install in restricted places such as the VLT® enclosure or the motor terminal box
Only 4 core sizes cover the entire VLT® power range	<ul style="list-style-type: none"> – Easy logistics, fast delivery and comprehensible product program – Allows the addition to a service tool-kit
Low investment	Cost-effective alternative to, for example, sine-wave filters if the only phenomena to be mitigated is bearing wear-out through electrical discharge

Ideal for retrofitting

Bearing current problems are most often discovered after commissioning. Therefore, the cores have an oval shape which makes them ideal for retrofitting and for installation in restricted places.

Only 4 variants cover the entire VLT® product range making it possible to carry these valuable aids in a service tool kit.

A flexible solution

The cores can be combined with other output filters, and especially in combination with dU/dt filters they offer a low cost solution for protection of both motor bearings and insulation.

Product range

- Available for all power sizes from 0.18 kW to 1.4 MW
- 4 core sizes cover the entire VLT® power range

HF-CM selector

The cores can be installed at the frequency converter's output terminals (U, V, W) or in the motor terminal box. When installed at the frequency converter's terminals, the HF-CM kit reduces bearing stress and high-frequency electromagnetic interference from the motor cable. The number of cores depends on motor cable length and frequency converter voltage. A selection table is shown to the right.

Cable length [m]	A and B frame		C frame		D frame		E and F frame	
	T5	T7	T5	T7	T5	T7	T5	T7
50	2	4	2	2	2	4	2	2
100	4	4	2	4	4	4	2	4
150	4	6	4	4	4	4	4	4
300*	4	6	4	4	4	6	4	4

* Longer cable lengths are easily handled by stacking more HF-CM cores.

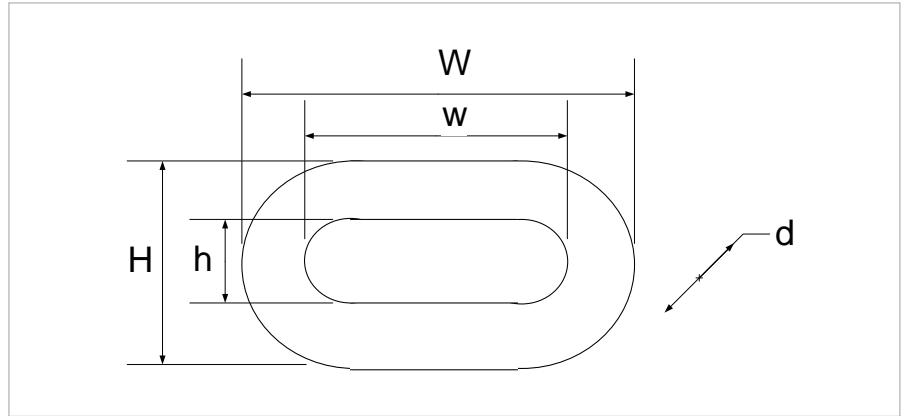

Ordering numbers and dimensions

Ordering numbers for the core kits (2 cores per package) are given in the table below.

VLT® Frame Size	Danfoss ordering number	Core dimension [mm]					Weight [kg]	Packaging dimension [mm]
		W	w	H	h	d		
A and B	130B3257	60	43	40	25	22,3	0.25	190 x 100 x 70
C1	130B7679	82,8	57,5	45,5	20,6	33		
C2, C3, C4	130B3258	102	69	61	28	37	1.6	190 x 100 x 70
D	130B3259	189	143	126	80	37	2.45	235 x 190 x 140
E and F	130B3260	305	249	147	95	37	4.55	290 x 260 x 110

Installation

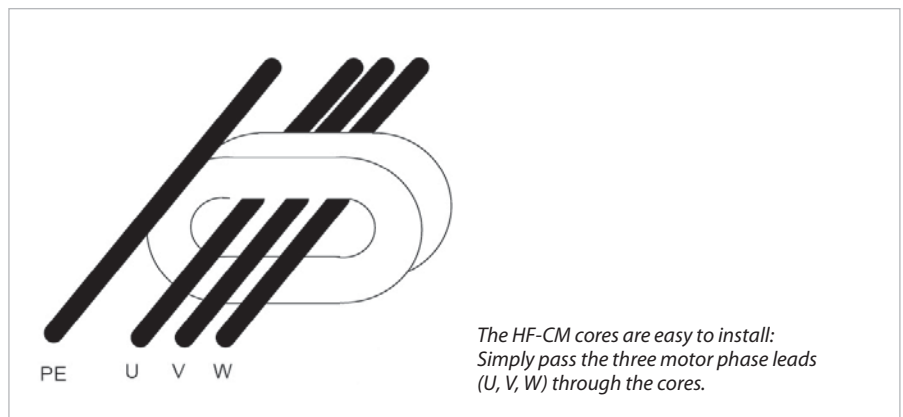

VLT® Sine-Wave Filter MCC 101



VLT® Sine-wave Filter MCC 101 output filters are low-pass filters that suppress the switching frequency component from the drive and smooth out the phase-to-phase output voltage of the drive to become sinusoidal. This reduces the motor insulation stress and bearing currents.

VLT® Sine-wave Filter MCC 101 output filters are differential-mode low-pass filters that suppress the switching frequency component from the drive and smooth out the phase-to-phase output voltage of the drive to become sinusoidal. This reduces the motor insulation stress and bearing currents.

By supplying the motor with a sinusoidal voltage waveform, the switching acoustic noise from the motor is also eliminated.

Thermal losses and bearing currents

The sinusoidal voltage supply to the motor reduces hysteresis thermal losses in the motor. Since the motor insulation lifetime is dependent on the motor temperature, the sine-wave filter prolongs the lifetime of the motor.

The sinusoidal motor terminal voltage from the sine-wave filter furthermore has the advantage of suppressing any bearing currents in the motor. This reduces the risk of flashover in the motor bearings and thereby also contributes to extended motor lifetime and increased service intervals.

Feature	Benefit
Supplies the motor with a sinusoidal voltage waveform	– Prevents flashover in motor windings
Eliminates over-voltages and voltage spikes caused by cable reflections	– Protects the motor insulation against premature aging
Reduces electromagnetic interference by eliminating pulse reflection caused by current ringing in the motor cable. This allows the use of unshielded motor cables in some applications.	– Trouble-free operation
Eliminates acoustic noise in motor	– Noiseless motor operation
Reduces high frequent losses in motor	– Prolongs service interval of motor

Quality and Design

All filters are designed and tested for operation with the VLT® Automation-Drive FC 302, VLT® AQUA Drive FC 202, and the VLT® HVAC Drive FC 102. They are rated for the nominal switching frequency of the VLT® FC series and therefore no derating of the drive is needed.

The enclosure is designed to match the look and quality of the VLT® FC series drives.

Advantages

- Compatible with all control principles including flux and VVC+
- Parallel filter installation is possible for applications in the high power range

Range

- 3 x 200 – 500 V, 2.5 – 800 A
- 3 x 525 – 690 V, 4.5 – 660 A

Enclosures

- IP 00 and IP 20 wall-mounted enclosure up to 75 A (500 V)/45 A (690 V)
- IP 23 floor-standing enclosure from 115 A (500 V)/76 A (690 V)

Mounting

- Side by side mount with the drive up to 75 A (500 V) and 45 A (690 V)

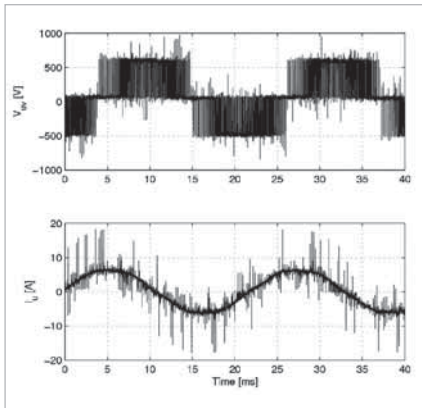

Voltage and current without filter

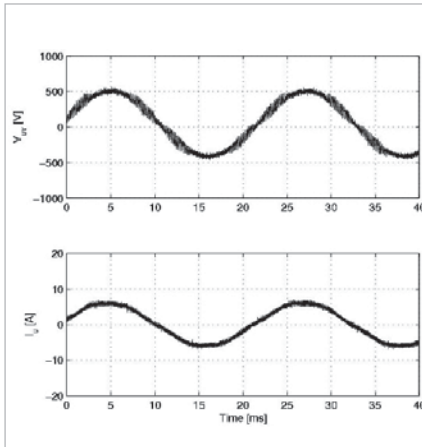

Voltage and current with filter

Specifications

Voltage rating	3 x 200 – 500 V and 3 x 525 – 690 V
Nominal current I _N @ 50 Hz	2.5 – 800A for higher power modules can be paralleled
Motor frequency	0 – 60 Hz without derating 100/120 Hz (up to 10 A) with derating
Ambient temperature	-25° to 45°C without derating
Min. switching frequency	f _{min} 1,5 kHz – 5 kHz depending on filter type
Max. switching frequency	f _{max} 8 kHz
Overload capacity	160% for 60 sec every 10 min.
Enclosure degree	IP 00/IP 20/IP 23 (ref. page 1)
Approvals	CE, UL508

Relative sound pressure measurements from the motor with and without sine-wave filter

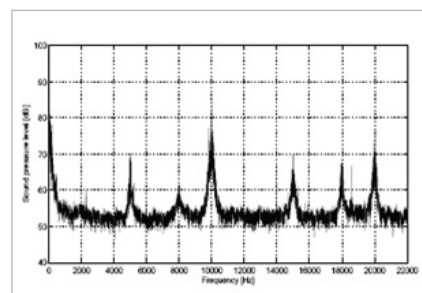

No filter

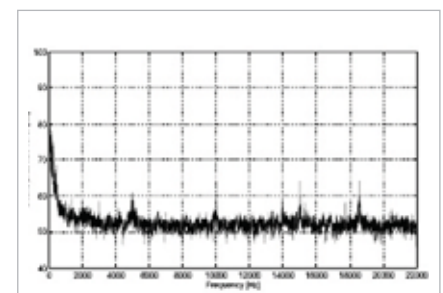

With sine-wave filter

Performance Criteria	du/dt filters	Sine-wave filters
Motor insulation stress	Up to 100 m cable (shielded/unshielded) complies with the requirements of IEC60034-17* (general purpose motors). Above this cable length the risk of "double pulsing" increases.	Provides a sinusoidal phase-to-phase motor terminal voltage. Complies with IEC-60034-17* and NEMA-MG1 requirements for general purpose motors with cables up to 500 m (1 km for frame size D and above).
Motor bearing stress	Slightly reduced, mainly in high power motors.	Reduces bearing currents caused by circulating currents. Does not reduce common-mode currents (shaft currents).
EMC performance	Eliminates motor cable ringing. Does not change the emission class. Does not allow longer motor cables as specified for the frequency converter's built-in RFI filter.	Eliminates motor cable ringing. Does not change the emission class. Does not allow longer motor cables as specified for the frequency converter's built-in RFI filter.
Max. motor cable length	100 m ... 150 m With guaranteed EMC performance: 150 m screened Without guaranteed EMC performance: 150 m unshielded	With guaranteed EMC performance: 150 m shielded and 300 m unshielded (only conducted emissions). Without guaranteed EMC performance: up to 500 m (1 km for frame size D and above).
Acoustic motor switching noise	Does not eliminate acoustic switching noise from the motor.	Eliminates acoustic switching noise from the motor caused by magnetostriction.
Relative size	15 – 50% (depending on power size).	100%
Relative price	50%	100%

*Not 690 V

VLT® dU/dt Filter MCC 102



VLT® dU/dt Filter MCC 102 reduce the dU/dt values on the motor terminal phase-to-phase voltage – an issue that is important for short motor cables.

VLT® dU/dt Filter MCC 102 are differential-mode low-pass filters which reduce motor terminal phase-to-phase peak voltages spikes and reduce the rise time to a level that lowers the stress on the insulation of motor windings.

Compared to sine-wave filters, the dU/dt filters have a cut-off frequency above the switching frequency. The voltage at the motor terminals is still PWM pulse shaped, but the rise time and U_{peak} are reduced. They are smaller, weigh less and have a lower price compared to sine-wave filters. Furthermore, because of the smaller inductance and capacitance, the dU/dt filters introduce a negligible reactance between inverter and motor and are therefore suitable for high dynamic applications.

Superior compared to output chokes

Output chokes cause undamped oscillations at the motor terminals which increase the risk of double pulsing and over-voltages higher than twice the DC link voltage. The dU/dt filters are low-pass L-C filters with a well defined cut-off

Feature

Reduces dU/dt stresses
Lowers the magnetic interference propagation on surrounding cables and equipment
Low voltage drop makes dU/dt filters the ideal solution for highly dynamic applications with flux vector regulation

Benefit

Increases motor service interval
Trouble-free operation
Small size and cost compared to sine-wave filters

frequency. Therefore the ringing oscillations at the motor terminals are damped and there is a reduced risk of double pulsing and voltage peaks.

Quality and Design

All dU/dt filters are designed and tested for operation with the VLT® AutomationDrive FC 302, VLT® AQUA Drive FC 202, and the VLT® HVAC Drive FC 102. They are designed to match the look and quality of the FC series.

Advantages

- Compatible with all control principles, including flux and VVC+
- Parallel filter installation is possible for applications in the high power range

Range

3 x 200 – 690 V (up to 880 A)

Enclosures

- IP 00 and IP 20/23 enclosure in the entire power range.
- IP 54 enclosure available up to 177 A.

Mounting

- Side by side mounting with the drive
- Filters wall mounted up to 177 A (380 V) and floor mounted above that size

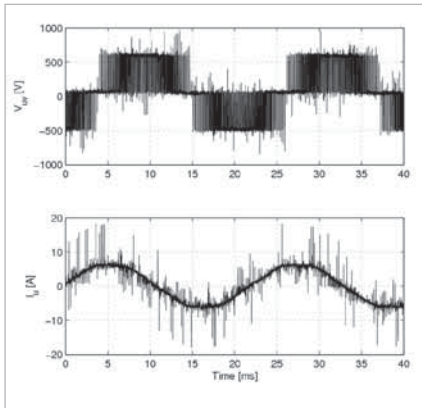

Voltage and current without filter

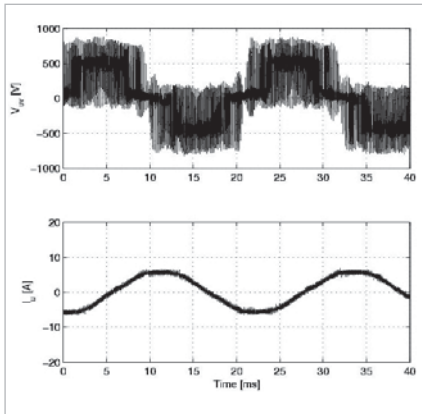

Voltage and current with filter

Specifications

Voltage rating	3 x 200 – 690 V
Nominal current I_N @ 50 Hz	44 – 880 A @ 200 – 380 V, 40 – 780 A @ 460 V 32 – 630 A @ 600 V and 27 – 630 A @ 690 V for higher power modules can be paralleled
Motor frequency	0 – 60 Hz without derating Max. 100 Hz (with derating)
Ambient temperature	-25° to 45° C without derating
Max. switching frequency	f_{sw} 1,5 kHz – 4 kHz depending on filter type
Mounting	Side-by-side
Overload capacity	160% for 60 sec every 10 min.
Enclosure degree	IP 00, IP 20/23 and IP 54
Approvals	CE, UL508

dU/dt limit curves

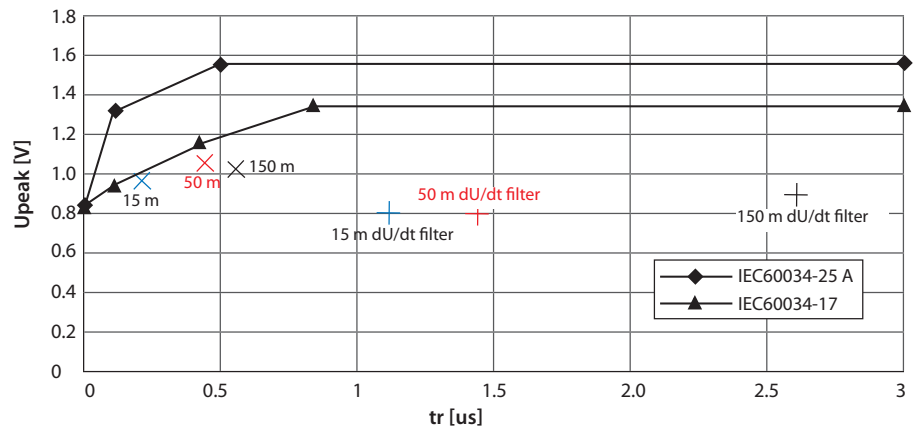

The dU/dt value decreases with the motor cable length whereas the peak voltage increases. Therefore it is recommended to use sine-wave filters in installations with motor cable lengths above 150 m.

Performance Criteria	du/dt filters	Sine-wave filters
Motor insulation stress	Up to 100 m cable (shielded/unshielded) complies with the requirements of IEC60034-17* (general purpose motors). Above this cable length the risk of "double pulsing" increases.	Provides a sinusoidal phase-to-phase motor terminal voltage. Complies with IEC-60034-17* and NEMA-MG1 requirements for general purpose motors with cables up to 500 m (1 km for frame size D and above).
Motor bearing stress	Slightly reduced, mainly in high power motors.	Reduces bearing currents caused by circulating currents. Does not reduce common-mode currents (shaft currents).
EMC performance	Eliminates motor cable ringing. Does not change the emission class. Does not allow longer motor cables as specified for the frequency converter's built-in RFI filter.	Eliminates motor cable ringing. Does not change the emission class. Does not allow longer motor cables as specified for the frequency converter's built-in RFI filter.
Max. motor cable length	100 m ... 150 m With guaranteed EMC performance: 150 m screened Without guaranteed EMC performance: 150 m unshielded	With guaranteed EMC performance: 150 m shielded and 300 m unshielded (only conducted emissions). Without guaranteed EMC performance: up to 500 m (1 km for frame size D and above).
Acoustic motor switching noise	Does not eliminate acoustic switching noise from the motor.	Eliminates acoustic switching noise from the motor caused by magnetostriction.
Relative size	15 – 50% (depending on power size).	100%
Relative price	50%	100%

*Not 690 V

VLT® Motion Control Tool MCT 10

Optimised

for:

- Commissioning
- Servicing
- Programming

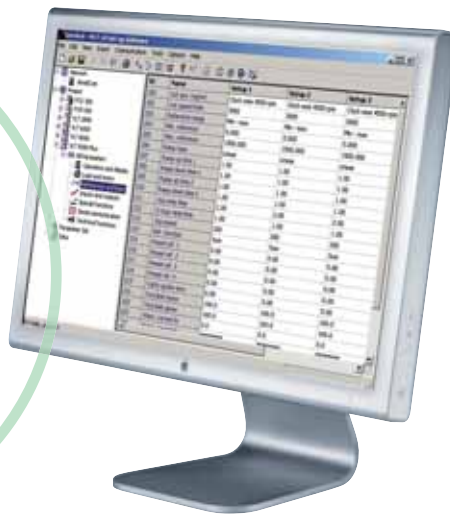

The VLT® Motion Control Tool MCT 10, is ideal for commissioning and servicing the drive including graphical configuration of cascade controller time-based actions, real-time clock, smart logic controller and preventive maintenance.

The setup software provides easy control of details as well as a general overview of systems, large or small. The tool handles all drive series, VLT® Advanced Active Filters and VLT® Soft Starter related data.

More efficient service organization

- Scope & logging: analyse problems easily
- Read out alarms, warnings and fault log in one view.
- Compare saved project with on-line drive
- Update drive or option firmware. One tool handling all
- Conversation wizard suitable for retrofit of VLT® 5000 to FC 302

More efficient commissioning

- Off-line commissioning off site
- Save/send/mail projects anywhere
- Easy field-bus handling, multiple drives in project file scalable to the application size

Feature	Benefit
One PC tool for all tasks	Save time
"Explorer-like" view	Easy to use
Option programming	Save time
Online and offline commissioning	Flexible and save cost
Scope & logging	Easy and fast analyzing – less downtime
Alarm history	Easy fault finding
Multiple interfaces	Easy connection
USB connection	Easy connection
Flexible Ethernet connection	Easy connection – save time (utilizing all Danfoss Ethernet based fieldbus options) Remote connection, also through different subnets

Basic version

- Off-line commissioning (max. 4 drives)
- Scope & Graph (max. 2 channels)
- Multiple fieldbus support
- Alarm history in saved projects
- MCO 305 support
- Graphical Smart Logic Controller
- Graphical Clock functions, Time-based Actions, Preventive Maintenance and Basic Cascade Controller (FC 102/FC 202 only)
- Update drive support to support new firmware (future compatible)
- FC drive conversion (FC 102/FC 202 & FC 300 series)

Advanced version

- Basic version functionality +
- No limitation in number of drives
- Scope & Graph (max. 8 channels)
- Real Time Logging from drive
- Motor Database
- Graphical Sensorless pump control
- Graphical Extended Cascade Controller (FC 202 only)
- Support for CSIV file creation and upload of CSIV-, SAS-, SPLASH- and language files to the drive
- Full drive password protection support
- Configuration support of the functional safety options

Fieldbusses

- PROFIBUS DP-V1
- RS485
- USB
- EtherNet-TSC

Internet download

For further information and download of the free basic version visit:
<http://www.danfoss.com/drives>

System requirements

- MS Windows® NT 4.0, 2000, XP, Vista 7 and 8
- Pentium III 350 MHz or better
- 512 MB RAM or better
- 200 MB free hard disk space
- CD-ROM drive
- VGA or XGA graphic adapter

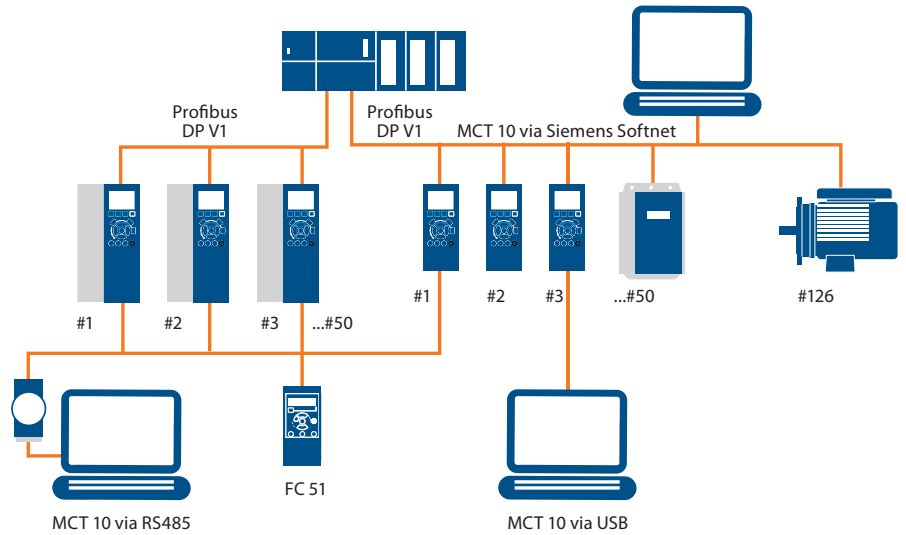

VLT® Motion Control Tool MCT 31

Optimised

for:

- Application specific simulations
- Various Power Supply sources
- Norm compliance indication
- Project Documentation



With VLT® Motion Control Tool MCT 31, you can determine whether harmonics will be an issue in your installation when drives are added. MCT 31 estimates the benefits of adding various harmonic mitigation solutions from the Danfoss product portfolio and calculates system harmonic distortion.

Save money and reduce running costs

On the basis that it is better to avoid a problem rather than cure one after it happens, it is preferable to calculate the effect of installing non-linear loads before doing so, to estimate the degree of harmonic distortion that may result.

Danfoss offers free to download, the VLT® Motion Control Tool MCT 31, a simple to use and fast software tool for calculating the harmonic distortion from your existing or intended drives installation.

A fast estimate is vital as, in this case, more is not better, simply more costly, so the MCT 31 can help save money when selecting harmonic mitigation solutions.

Simply over-specifying a harmonic mitigation solution will lead to unnecessary initial cost escalation and increased running expenses.

Feature

Explore-like view

Simple simulation model with less parameters

Configurable for various Power supply sources

One tool supporting all Danfoss harmonic mitigation solutions

Configurable Norm compliance indication

User configurable reports

Simulate the setup before installation

Benefit

Easy to use

Easy to use and fast simulation – save time

Matching all customer needs

Matching all customer needs

Save time

Project documentation

Save time and money. Prevent problems appear later

Calculate the harmonic disturbance

The MCT 31 tool can easily be used to evaluate the expected grid quality and includes a range of passive and active counter-measures which can be selected to ease system stress.

The power quality impact of electronic devices can be estimated in the frequency range up to 2.5 kHz, depending on the system configuration and standard limits.

The analysis includes indication of compliance with various standards and recommendations.

The Windows-like interface of the MCT 31 tool makes possible intuitive

operation of the software. It is built with a focus on user-friendliness and the complexity is limited to system parameters that are normally accessible.

The Danfoss VLT® frequency converter and mitigation equipment is included, allowing offline configuration.

Your local Danfoss consultant will be very happy to provide all the assistance you need to evaluate your power quality and advice in the selection of the correct mitigation for your circumstances.

Internet download

For further information and download of the MCT 31 software visit:
<http://www.danfoss.com/drives>

System requirements

- MS WindowsR NT 4.0, 2000, XP, Vista or 7
- Pentium III 350 MHz or better
- 512 MB RAM or better
- 200 MB free hard disk space
- CD-ROM drive
- VGA or XGA graphic adapter

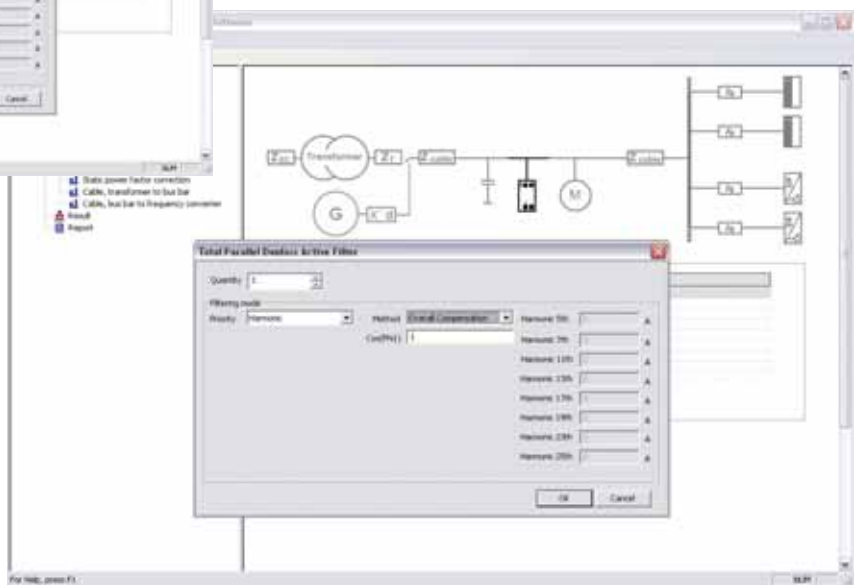
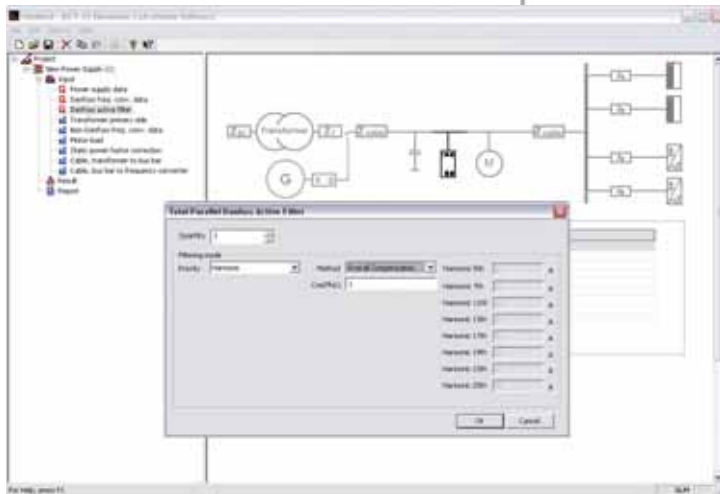
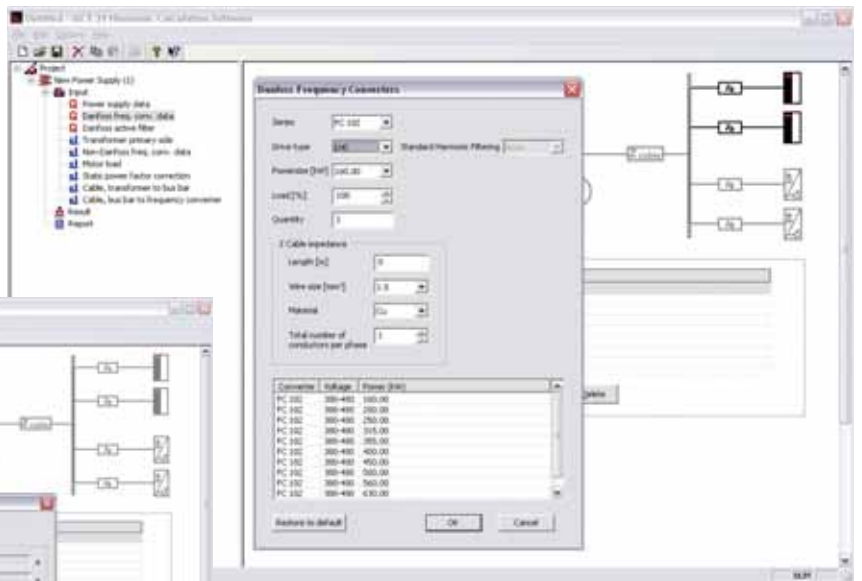
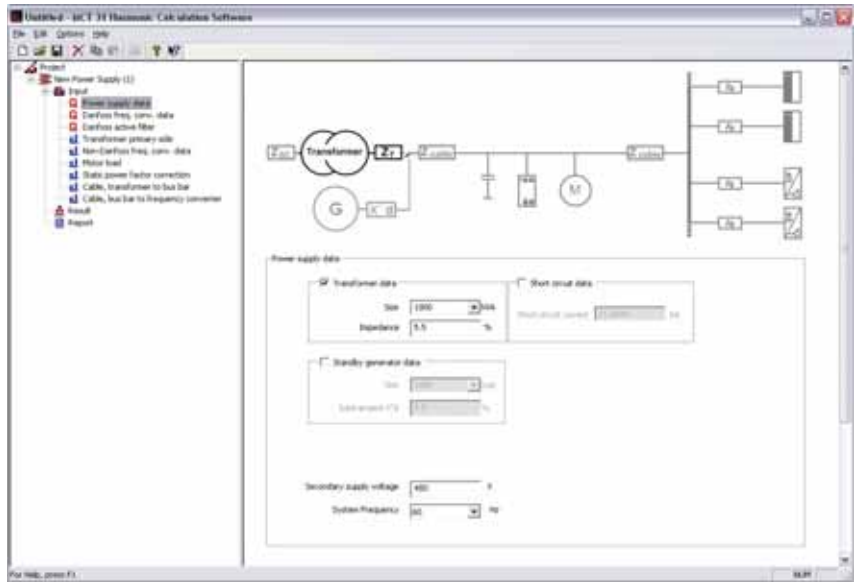

VLT® Energy Box

Optimised

for:

- Designing HVAC installations
- Obtaining energy savings
- Calculating pay-back time



With the VLT® Energy Box Software you can early in the project estimate the energy savings. Later you can easily compare your estimations with the actual energy savings and carbon footprint reduction using the trend and energy data stored in your drive.

VLT® Energy Box makes energy consumption calculations of fan, pump and cooling tower applications driven by VLT® HVAC Drives from Danfoss and compares it with alternative methods of flow control.

The program compares the total operation costs of various traditional systems compared to operation of the same system with a VLT® HVAC Drive.

With the VLT® Energy Box Software you can early in the project estimate the energy savings. Later you can easily compare your estimations with the actual energy savings and carbon footprint reduction using the trend and energy data stored in your drive.

The VLT® Energy Box communicates with the drives through the USB/RS485 port and can read all data about duty cycles and energy consumptions.

Data about duty cycles and energy consumptions can be downloaded from the VLT® HVAC Drive, making it easy to monitor your energy savings and return on investment. Monitoring via fieldbus often makes energy meters ommissible.

Feature

- Estimate savings
- Calculates pay back based on investments and annual costs
- Generates a report
- Special cooling tower mode based on climate data
- Possible to adjust climate region to local conditions
- Download of energy data from the drive via serial communication and USB
- Covers several projects and systems in same file

Benefit

- Make purchase decision easy
- Economical overview
- Easy communication
- Easy calculation
- More accurate calculations
- Facilitates the drives payback function
- Visualize actual load profile
- Generation of common project report

The software allows you to download trend and energy data from your drive and even create one report with the total energy savings, if you have several drives in the same system.

Complete financial analysis

VLT® Energy Box provides a complete financial analysis including:

- Initial cost for the drive system and the alternative system
- Installation and hardware costs

- Annual maintenance costs and any utility company incentives for installation of energy conservation products
- Payback time and accumulated savings and carbon footprint are calculated

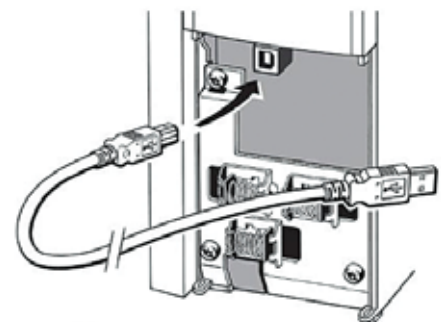

No nonsense

Since VLT® Energy Box both estimates and afterwards can compare the estimation to the real energy savings the real energy savings, it is a very trustworthy means for calculating projects involving many fans, pumps and cooling towers. You can simply install a single VLT® HVAC Drive and check the actual savings to exactly calculate the benefits from installing VLT® HVAC Drives on the other applications.

Internet download

The software can be downloaded free of charge from:
<http://www.danfoss.com/drives>

System requirements

- Windows XP, Vista, 7 or 8
- 512 MB RAM or better
- VGA or higher with a minimum resolution of 1024 x 768
- 30 MB free harddisk Space

Considers local conditions

VLT® Energy Box use local weather data in its calculations for cooling towers.

Data from weather zones around the Globe are pre-installed, but the user is free to adjust these data according to local conditions.

Specify the curve

Energy Box offers an advanced mode to specify the fan or pump curve in more detail.

The fan or pump (equipment) curve can be adjusted to match almost any shape.

Choose flow and pressure points to generate an equipment curve similar to the published fan or pump curve over the relevant section of the curve using the mechanical flow control method.

The program will not allow calculations in regions that are in a surge region or beyond the end of the curve.

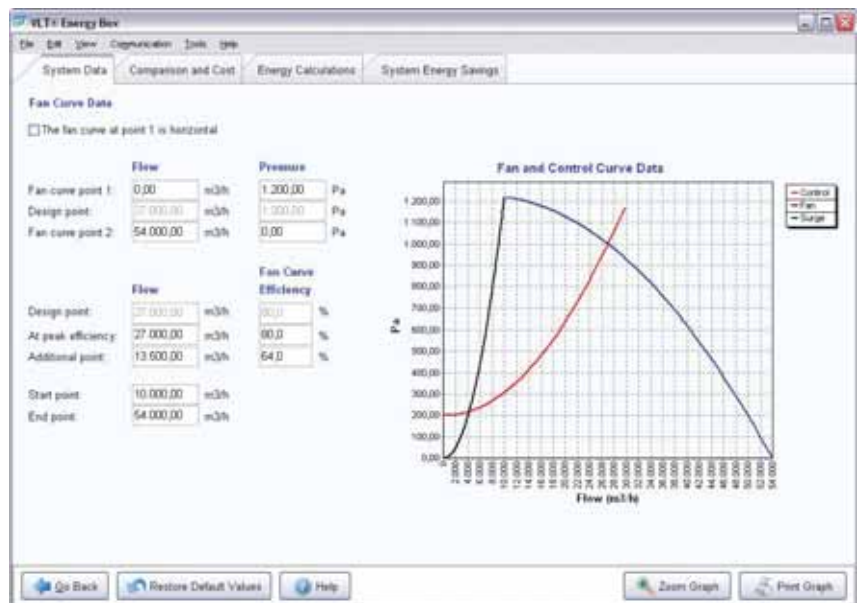
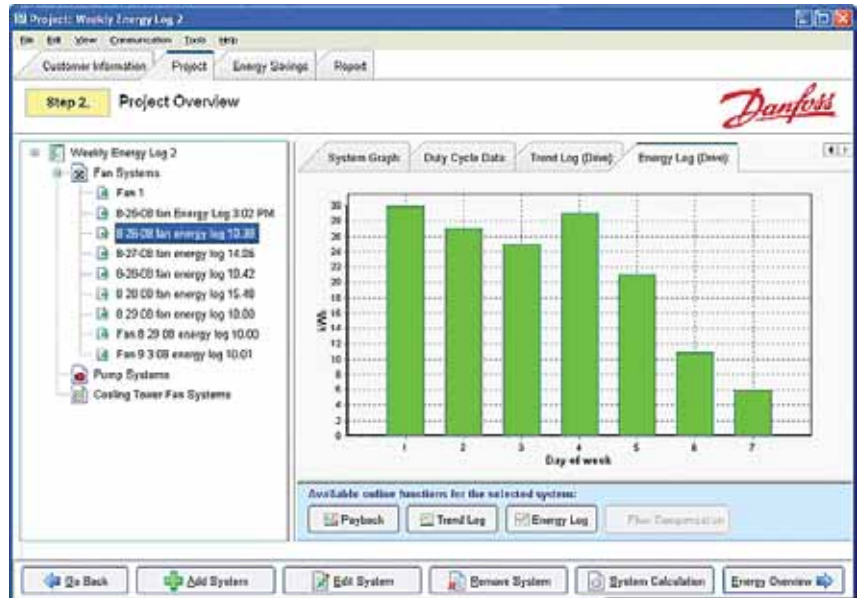

VLT® Service

VLT® DrivePro™

LifeCycle Service Packages

VLT® DrivePro™ Plus

The Plus Package offers a program of support to help customers realize improved drive availability and reliability.

Features

- Preventative Maintenance
- Standard Training
- 24 hour Hotline
- 24 hour response time
- On-site service

VLT® DrivePro™ Premium

Our Premium Program provides a combination of basic and advanced service and support resources aimed at extending the life of your drives and ensure peak economic performance.

Features

- Preventative Maintenance
- Standard and scheduled training
- 24 hour Hotline
- 6 hour response time
- On-site service, inc. labour & travel
- Start-up
- Extended warranty – Depot
- Extended warranty – On-site
- Environmental disposal

VLT® DrivePro™ Supreme

The Supreme Package provides a full scope of service to meet your operational needs, help you achieve business critical KPI metrics and last but not least give you total peace of mind.

Features

- Preventative Maintenance
- Customer-specific training
- 24 hour Hotline
- 6 hour response time
- On-site service, inc. labour & travel
- Start-up
- Extended warranty – Depot
- Extended warranty – On-site
- Environmental disposal
- Analysis and surveys
- Spare Parts/Drives
- SmartStep
- Stock Maintenance & Consignment
- Stock

VLT® DrivePro™

SmartStep

Upgrade and replace equipment proactively for total peace of mind

Upgrade sensibly

DrivePro™ SmartStep is a comprehensive replacement and upgrade program for customers to assure optimal efficiency and cost performance. It's an easy upgrade program for substantially reduced cost that's backed by professional service support.

DrivePro™ SmartStep advantages

- Customized service and upgrade program
- Flexible replacement plan
- Fixed costs

Designed for success

- Minimize down-time costs
- Extend mean-time-to-repair intervals
- Control your maintenance budget
- Avoid unexpected investments in equipment

Available for application areas such as:

- Food & Beverage
- HVAC
- CTM (chemical, textile, materials)
- Water and wastewater

Service you can rely on 24/7 – around the world

Sales and Service

Contacts worldwide. Helping to optimise your productivity, improve your maintenance, and control your finances.

- 24/7 availability
- Local hotlines, local language and local stock

The Danfoss service organisation is present in more than 100 countries – ready to respond whenever and wherever you need, around the clock, 7 days a week.

Find your local expert team on www.danfoss.com/drives

Configure your VLT® drive to fit your needs on <http://driveconfig.danfoss.com>

The Drive Configurator gives you the possibility to configure (select) the right drive for your purpose. You don't have to consider if the combinations are valid, while the configurator only gives you valid selections.

Drive Configurator

The Danfoss Drive Configurator is an advanced but easy-to-use tool to configure the Danfoss VLT® frequency converter that exactly matches your requirements.

The Drive Configurator generates the unique article number for the drive you need, preventing errors during order entry.

"Decoding" is also available: Enter a Typecode and the Drive Configurator will decode the configuration and show configuration for your drive.

"Reverse engineering" is also supported: Enter an article number and the Drive Configurator will display the exact configuration for the drive in question, including all options and special features. A further advantage of using the Drive Configurator is that it tells you exactly which options and features are available and so prevents you selecting conflicting or nonsensical combinations.

If you need to replace an obsolete product, just enter the article number of the older VLT® and the Drive Configurator will provide details of the appropriate newer generation replacement.

Last but by no means least, the Drive Configurator provides quick access to the available spare parts and accessories for both current and obsolete products.

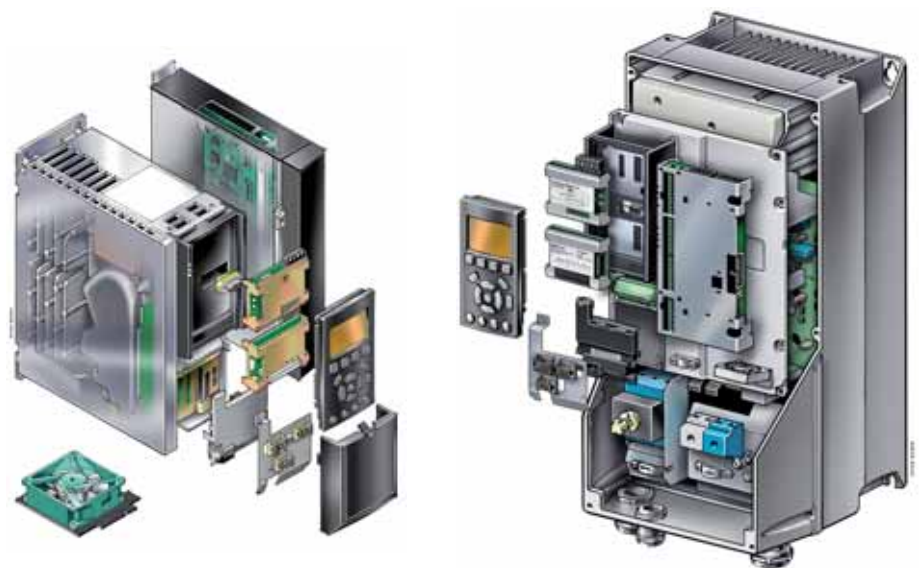
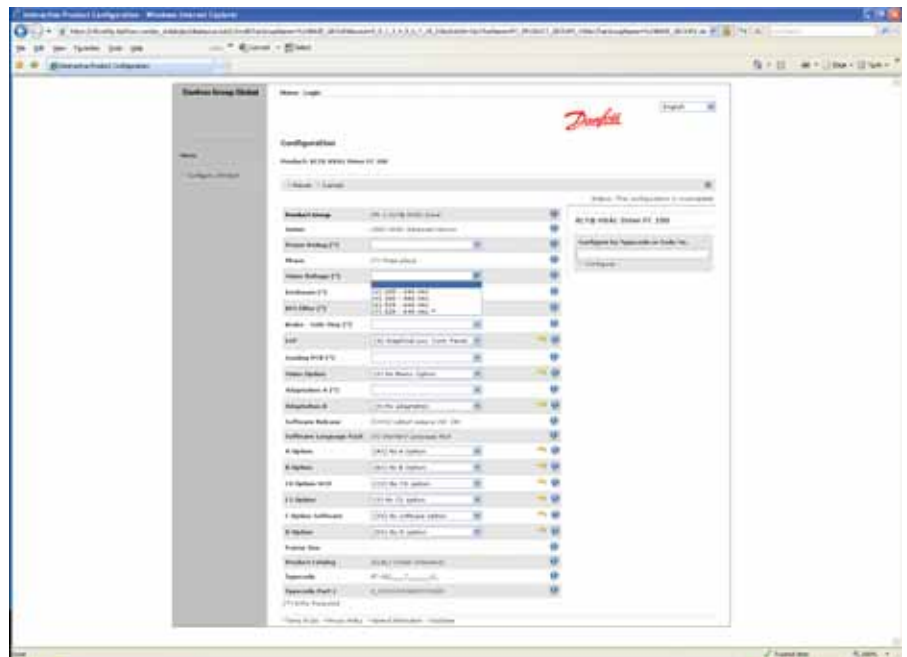



What VLT® is all about

Danfoss VLT Drives is the world leader among dedicated drives providers – and still gaining market share.

Environmentally responsible

VLT® products are manufactured with respect for the safety and well-being of people and the environment.

All frequency converter factories are certified according to ISO 14001 and ISO 9001 standards.

All activities are planned and performed taking into account the individual employee, the work environment and the external environment. Production takes place with a minimum of noise, smoke or other pollution and environmentally safe disposal of the products is pre-prepared.

UN Global Compact

Danfoss has signed the UN Global Compact on social and environmental responsibility and our companies act responsibly towards local societies.

Impact on energy savings

One year's energy savings from our annual production of VLT® drives will save the energy equivalent to the energy production from a major power plant. Better process control at the same time improves product quality and reduces waste and wear on equipment.

Dedicated to drives

Dedication has been a key word since 1968, when Danfoss introduced the world's first mass produced variable speed drive for AC motors – and named it VLT®.

Twenty five hundred employees develop, manufacture, sell and service drives and soft starters in more than one hundred countries, focused only on drives and soft starters.

Intelligent and innovative

Developers at Danfoss VLT Drives have fully adopted modular principles in development as well as design, production and configuration.

Tomorrow's features are developed in parallel using dedicated technology platforms. This allows the development of all elements to take place in parallel, at the same time reducing time to market and ensuring that customers always enjoy the benefits of the latest features.

Rely on the experts

We take responsibility for every element of our products. The fact that we develop and produce our own features, hardware, software, power modules, printed circuit boards, and accessories is your guarantee of reliable products.

Local backup – globally

VLT® motor controllers are operating in applications all over the world and Danfoss VLT Drives' experts located in more than 100 countries are ready to support our customers with application advice and service wherever they may be.

Danfoss VLT Drives experts don't stop until the customer's drive challenges are solved.

