

## Data sheet

# NovoCon® S

## Description



NovoCon® S is a high accuracy multi-functional field bus actuator, specifically designed for use in combination with the Pressure Independent Balancing Control Valve type AB-QM in sizes from DN 10-32.

The flow is modulated by the AB-QM pressure independent control valve to avoid overflow and reduced boiler and/or chiller efficiency.

The actuator with AB-QM is used to control water supply to fan coil units, chilled beams, induction units, small re-heaters, re-coolers, AHU's and other terminal units for zone control, in which heating/ chilled water is the controlled medium. Due to its accuracy, remote functionality and flow indication features, this product facilitates an accelerated commissioning process, allows easy maintenance, improves indoor comfort, increases energy savings and allows for fair cost allocation of heat/cool energy.

The high position accuracy of the actuator, together with the pressure independent and linear characteristic of the AB-QM valve, allow NovoCon® S to be used as a flow indicator.

Setup of the actuator and valve parameters are made via fieldbus. Control is achieved via field bus or via analog inputs to NovoCon® S.

### Typical applications are:

- Radiant ceiling panels, supplied by 4 pipes (Heating supply and return and cooling supply and return).
- Fan coil units, with single coils supplied by 4 pipes (Heating supply and return and cooling supply and return).

### General features:

- Remote commissioning/Pre-set/Flush features
- Flow indication
- High position accuracy
- Energy management applications
- 4/2-pipe changeover applications
- I/O applications
- LED bar displaying status
- No tools required for mounting
- Maintenance-free lifetime
- Self-positioning process
- Low-noise operation
- Plug-in halogen free cables
- Auto MAC addressing for BACnet
- Auto baud rate detection

- Intrinsic alarm reporting for BACnet
- Valve blockage alarm
- Broken wire detection on analog control and ground signal
- Choice of BACnet MS/TP or Modbus RTU in the same product
- Mis-wiring protection on any wire up to 30 V

Combined with the Actuator NovoCon® ChangeOver®, NovoCon® S offers a unique solution in controlling both the AB-QM valve and a 6-port motorised ball valve that performs a diverting function between two water circuits in 4-pipe changeover systems.

This diverting function, primarily used for radiant panels, also allows the cooling and heating capacity of a fan coil unit to be increased for the same compact size compared to a double coil model where the heating and cooling water circuits each have their own coil.

The 6-port diverting valve and actuator work in combination with an AB-QM PIBCV valve and NovoCon® S bus actuator. The AB-QM balances the flow and the NovoCon® S bus actuator controls the flow. NovoCon® S also controls the 6-port diverting valve actuator which switches between heating and cooling. This unique functionality is characterized by the following:

- There is only one single field bus and power supply connection cable to the NovoCon® S actuator. This powers both the NovoCon® S and controls the 6-port actuator. Furthermore, there is feedback from the 6-port actuator to NovoCon® S.
- The NovoCon® S actuator automatically fault-detects, by means of comparing 0-10V control & feedback signals, if the 6-port actuator is in manual operation mode, removed from the valve or if the 6-port valve is blocked.
- The NovoCon® S actuator has two Design Flow Rate pre-settings: one for heating and another for cooling.
- The NovoCon® S actuator indicates power emission and logs energy usage for heating and cooling energy based on flow, supply and return pipe temperature measurement.
- While in maintenance mode, the 6-port actuator is able to fully close the valve and prevent any leakage, thereby saving on stop valves.
- Logic contained within the NovoCon® S actuator, ensures that only one actuator in each pair (NovoCon® S and 6-port valve actuator) drives. This ensures that 2 actuators in the pair never drive at the same time. This reduces voltage booster demands in daisy chains.
- The NovoCon® S actuator detects if the 6-port actuator cable is disconnected. If this is the case an alarm is initiated.

Description (continued)

Features CO6:

- NovoCon® S + ChangeOver<sup>6</sup> actuator represents only ONE device on the fieldbus network needing no physical I/O
- No cross-flow between heating and cooling
- Simple connection and control
- Feedback for position status and alarms
- Quiet and reliable operation
- Maintenance free
- Teflon seal and polished chrome valve ball to prevent valve sticking
- Blocked valve alarm
- Manual override

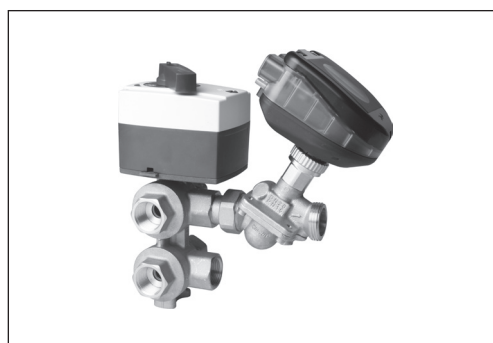

Features Energy:

- Supply and return temperature measurement
- Power/emission indication reading
- Energy Management functionality for both heating and cooling e.g. minimum delta t management
- Energy logging of both heating and cooling

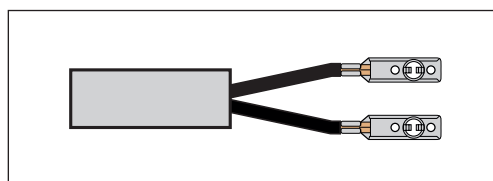

Features I/O:

- Connect to other devices and present them on the field bus, e.g. room thermostat, window contact, CO2 sensor, humidity sensors, fan control, 0-10V actuator etc.
- Select temperature units, Ohms or use as

potential free contacts. Closed circuit <900Ω, open circuit 100kΩ.

- Available connections: 1 x analog output (V), 1 x analog input (V/mA) and 2 x resistance based inputs (°C/°F/Ohms)

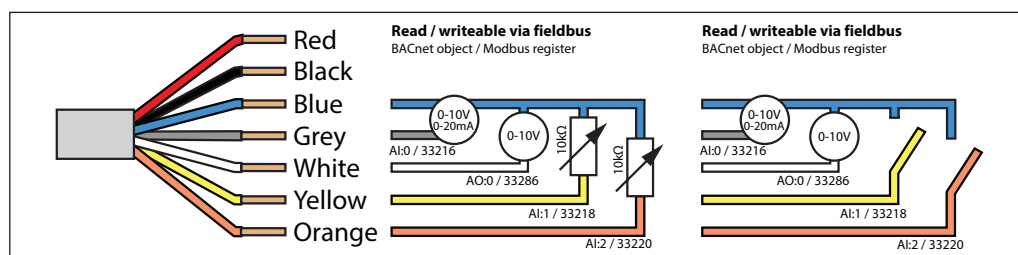

Ordering



Type	Code No.
NovoCon® S	003Z8504

Accessories



Type	Length	Connections	Cable material	Code No.
Cable NovoCon® Digital	1.5 m	bus / power	Halogen free	003Z8600
Cable NovoCon® Digital	5 m	bus / power	Halogen free	003Z8601
Cable NovoCon® Digital	10 m	bus / power	Halogen free	003Z8602
Cable NovoCon® Digital, daisy chain	0.5 m	actuator / actuator	Halogen free	003Z8609
Cable NovoCon® Digital, daisy chain	1.5 m	actuator / actuator	Halogen free	003Z8603
Cable NovoCon® Digital, daisy chain	5 m	actuator / actuator	Halogen free	003Z8604
Cable NovoCon® Digital, daisy chain	10 m	actuator / actuator	Halogen free	003Z8605
Cable NovoCon® Analog	1.5 m	0-10 V / power / voltage booster	Halogen free	003Z8606
Cable NovoCon® Analog	5 m	0-10 V / power / voltage booster	Halogen free	003Z8607
Cable NovoCon® Analog	10 m	0-10 V / power / voltage booster	Halogen free	003Z8608
Cable NovoCon® I/O	1.5 m	actuator / free wires	Halogen free	003Z8612

**Note!** Cables are not included with actuator and must be ordered separately.



Cable NovoCon® Energy	1.5 m	Plug-in cable with PT1000 surface temperature sensors	PVC	003Z8610
Cable NovoCon® Energy	1.5 m	Plug-in cable with PT1000 Immersed /universal temperature sensors	PVC	003Z8611

**Note!** If separate PT1000 temperature sensors are needed, Danfoss has an array of PT1000 sensors that can be used with NovoCon® S. See Danfoss PT1000 sensors ESMT, ESM-10, ESM-11, ESMB-12, ESMC and ESMU.

ChangeOver<sup>6</sup> actuators



Actuator NovoCon ChangeOver <sup>6</sup>	1 m	Plug-in	Halogen free	003Z8520
Actuator NovoCon ChangeOver <sup>6</sup> Energy	1 m Temp. sensors 1.5m	Plug-in incl. PT1000 surface temperature sensors	Halogen free, sensors PVC	003Z8521
Actuator NovoCon ChangeOver <sup>6</sup> Flexible	2 m	Actuator / open wires	PVC	003Z8522

## Data sheet

## NovoCon® S

### Ordering (continued)

Type	DN	Fire load class <sup>1)</sup>	Code No.
ChangeOver <sup>6</sup> insulation	15	B2	<b>003Z3159</b>

<sup>1)</sup> According to D/N 4102

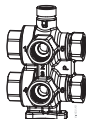

Type	DN	k <sub>vs</sub> (m <sup>3</sup> /h)	Connection	Code No.
ChangeOver <sup>6</sup> valve	15	2,4	Rp ½	<b>003Z3150</b>
	20	3,8	Rp ¾	<b>003Z3151</b>

### Accessories and spare parts (Cable NovoCon® Energy)

Type	Designation	Code No.
Pocket	Immersion, stainless steel 100 mm, for Cable NovoCon® Energy ( <b>003Z8611</b> )	<b>087B1192</b>
	Heat conducting paste, 3,5 cm <sup>2</sup>	<b>041E0110</b>

### Service kit - combination with old AB-QM

Type	Code No.
NovoCon® adapter for AB-QM, DN 10-32 (5 pcs.)	<b>003Z0239</b>

### Approvals



EMC Directive 2014/30/EU, EN 60730-2-14:1997, EN 60730-2-14/A1:2001, EN60730-1:2011  
RoHS Directive 2011/65/EU

### Technical data

Power supply range	24 V AC/DC, 50 / 60 Hz *
Power consumption	3.3 VA@24VAC / 1.4 W@24V DC / Standby: 0.9 W
Protection class	III safety extra-low voltage
Control signal NovoCon® S	BACnet MS/TP, Modbus RTU 0-10 VDC, 0-5 VDC, 2-10 VDC, 5-10 VDC, 2-6 VDC, 6-10 VDC, 0-20 mA, 4-20 mA
Actuator speed selections (open to close)	3 sec/mm, 6 sec/mm, 12 sec/mm, 24 sec/mm, Constant Time
Stroke	7 mm
Force	90 N
Position accuracy	± 0.05 mm
Ambient temp. range	-10° C to 50° C
Ambient humidity	98% r.h., non-condensing (according to EN 60730-1)
Max. medium temp.	120° C
Storage temp. range	-40 to 70° C
Grade of enclosure	IP 54 (IP 40 upside down)
Weight	0.4 kg

\* NovoCon® S is designed to operate at power deviations up to ±25%.

### BACnet data

Type	Length
BACnet device profile	BACnet Application Specific Controller (B-ASC)
BACnet protocol	BACnet Master Slave / Token Passing (MS/TP)
BACnet baud rates supported	Auto baud rate detection* / 9600 bps / 19200 bps / 38400 bps / 56700 bps / 76800 bps / 115200bps

### Modbus RTU data

Supported baud rates	Auto baud rate detection* / 9600 bps / 19200 bps / 38400 bps / 56700 bps / 76800 bps / 115200bps
Supported transmission modes	Parity: None (1-8-N-2) / Odd (1-8-O-1) / Even (1-8-E-1) / None (1-8-N-1) / Auto parity* Data format: Parity (Start bit - Data bits - Parity - Stop bits)

\* Default

### Dimensions

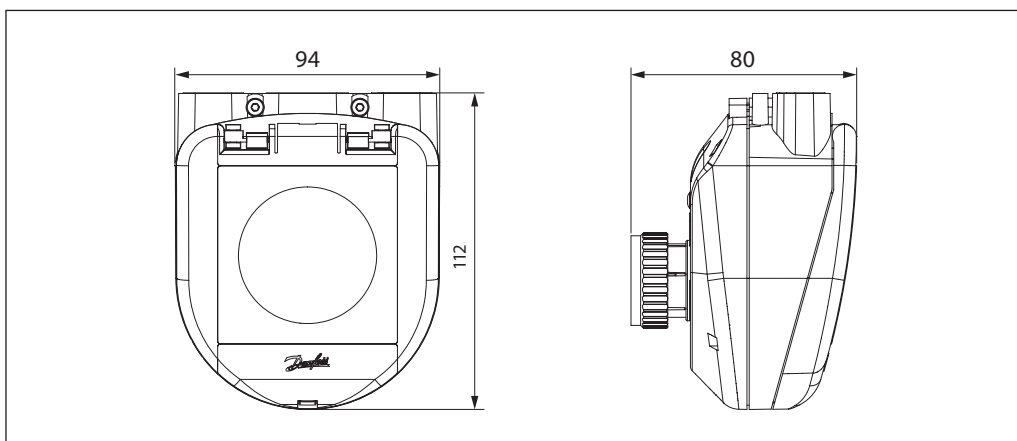

**Presetting**

Pre-setting of flow (maximum allowable flow though the valve) is achieved electronically with the NovoCon® S actuator. The pre-set scale on the AB-QM valve is not used under normal operation.

**Normal operation**

Leave valve at default factory pre-set (100 %).

**High flow operation**

In order to achieve a more efficient flush and enable pre-setting of the valve more than 100%, it is recommended to manually pre-set the AB-QM valve to maximum flow. This is done by turning the pre-set scale counter-clockwise until it stops.

See drawing.

Details about AB-QM pre-setting can be found in the AB-QM data sheet.

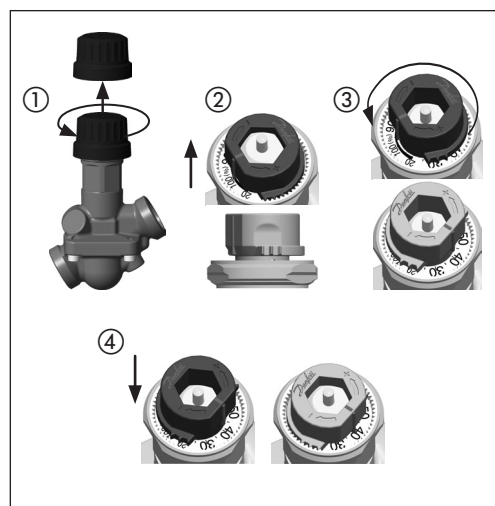

**Design**

- ① Removable lid
- ② Bus and power connections
- ③ LED window
- ④ Locking ring
- ⑤ Manual override
- ⑥ Reset button
- ⑦ DIP switches

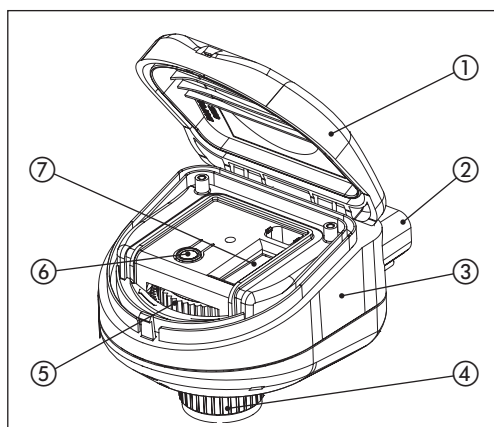

**Mounting Orientation**

NovoCon® S can be mounted in any position. However, mounting orientation affects the IP classification. See illustration.

**Note!**

IP classification is only valid when cable or plugs are present in all connections.

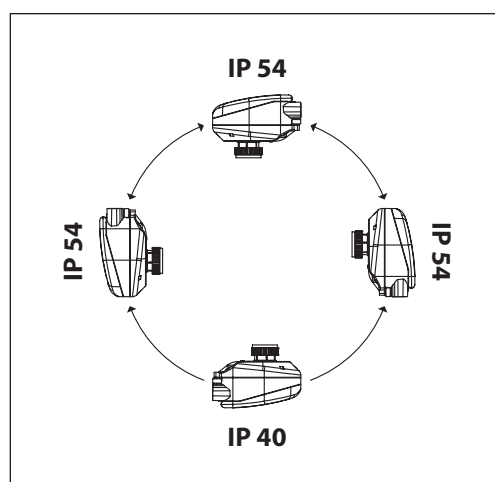

**Application principles  
NovoCon® S I/O**

When combining the NovoCon® S and the Cable NovoCon® I/O, many options are possible

**Operation example (DDC command)**

Object /Register	Write value	Description
AV:1 / 33280	85	DDC writes % opening value of the AB-QM valve
AO:0 / 33286	5.5	DDC writes level of voltage on NovoCon® S analog output, which is sent to the connected remote device

**Read on the BMS example**

Object /Register	Read value	Description
AO:0 / 33286	5.5	Voltage output from NovoCon® S to remote device
AI:0 / 33216	6.5	Voltage level on the analog control input measured by the actuator (may also be mA)
AI:1 / 33218	1160	Resistance value (Ohm) received from remote device 1
AI:2 / 33220	1263	Resistance value (Ohm) received from remote device 2

*Resistance inputs can also be used as galvanic insulated digital inputs for detection of window contact, condensation switch etc. Connected: <900 Ohm. Disconnected 100 kOhm.*

**Application principles  
NovoCon® I/O and  
Multiplexers/Relays**

Multiplexers and relays (analog-digital-analog convertors) in combination with NovoCon® S, may be used to gather information on, or control on/off devices.

Using NovoCon's 0-10V output signal (AO:0 / 33286), multiplexer relays convert this signal in order to switch devices on or off e.g. 7V signal from NovoCon® S is converted inside the multiplexer so device1=on, device 2=on, device3=off. E.g. 4V signal from NovoCon® S is converted inside the multiplexer so the device1=on, device 2=off, device3=off.

Using NovoCon's 0-10V input signal (AI:0 / 33216) received from the multiplexers, the DDC can decipher the meaning of the voltage signal e.g. 7V signal to NovoCon® S from the multiplexer is deciphered by the DDC as meaning device1=on, device 2=on, device3=off. 4V signal to NovoCon® S from the multiplexer is deciphered by the DDC as meaning device1=on, device 2=off, device3=off.

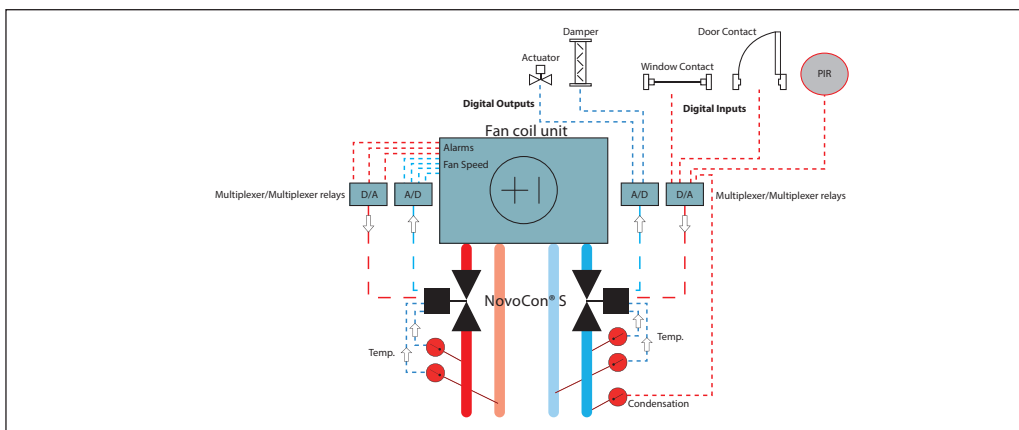

**Application principles:  
Central Plant Changeover  
– 2 pipe system**

Object / Register	Write/ read value	Description
MSV:9 / 32810	CO6 mode without alarms	The Heating and Cooling Design flow values below may be used.
MSV:3 / 32802	Selected Valve Type	ISO valve selected = l/h, °C, kW and kg/m³. ANSI valve selected = GPM, °F, kBTU and lb/ft³
AV:30 / 32796	250	Design flow setting of Heating e.g. 450 l/h
AV:31 / 32798	400	Design flow setting of Cooling e.g. 250 l/h
MSV:10 / 32811	Cooling	When the system is changed from central Heating to central Cooling the affected NovoCons may be written to so the correct Design flow will be adopted.

**Application principles  
ChangeOver<sup>6</sup> - 4 pipe system**

Separate maximum flow pre-setting for heating and for cooling  
**Setup**

Object / Register	Write/read value	Description
MSV:9 / 32810	CO6 mode	While in CO6 mode, the V/mA input and output signals are used purely for controlling the 6-port valve actuator
MSV:3 / 32802	Selected Valve Type	ISO valve selected = l/h, °C, kW and kg/m <sup>3</sup> . ANSI valve selected = g/min, °F, kBTU and lb/ft <sup>3</sup>
AV:30 / 32796	400	Design flow setting of Heating e.g. 400 l/h
AV:31 / 32798	250	Design flow setting of Cooling e.g. 250 l/h

**Application principles  
ChangeOver<sup>6</sup> Energy**

**Setup**

Object / Register	Write/read value	Description
MSV:9 / 32810	CO6 mode	While in CO6 mode, the V/mA input and output signals are used purely for controlling the 6-port valve actuator
AV:32 / 33288	Power emission	Calculates energy based on values from flow feedback (AV:2) and temperature (AI:1 and AI:2)
AV:33 / 33290	Heating Energy Counter	Accumulate Energy counter for heating
AV:34 / 33292	Cooling Energy Counter	Accumulate Energy counter for cooling
MSV:3 / 32802	Selected Valve Type	ISO valve selected = l/h, °C, kW and kg/m <sup>3</sup> . ANSI valve selected = g/min, °F, kBTU and lb/ft <sup>3</sup>
AI:1 / 33218	Temperature	Select between temperature units or ohms
AI:2 / 33220	Temperature	Select between temperature units or ohms
AV:30 / 32796	400	Design flow setting of Heating e.g. 400 l/h
AV:31 / 32798	250	Design flow setting of Cooling e.g. 250 l/h

**Application principles  
ChangeOver<sup>6</sup>**

The ChangeOver<sup>6</sup> is a 6-port valve with a rotary actuator that switches the flow between heating and cooling. An AB-QM pressure independent balancing and control valve with an actuator is used to balance the system and modulate the flow. When using the NovoCon® S for flow control, both NovoCon® S and the Actuator NovoCon® ChangeOver<sup>6</sup> are represented on the fieldbus network and need no physical I/O for control.

**Anti-sticking requirements:**  
To reduce the risk of the ball valve sticking due to water quality, the valve must be partially rotated at least every 7 days. This is a factory default setting and is handled by the object MSV:11 / register 32812.

**Cooling:**

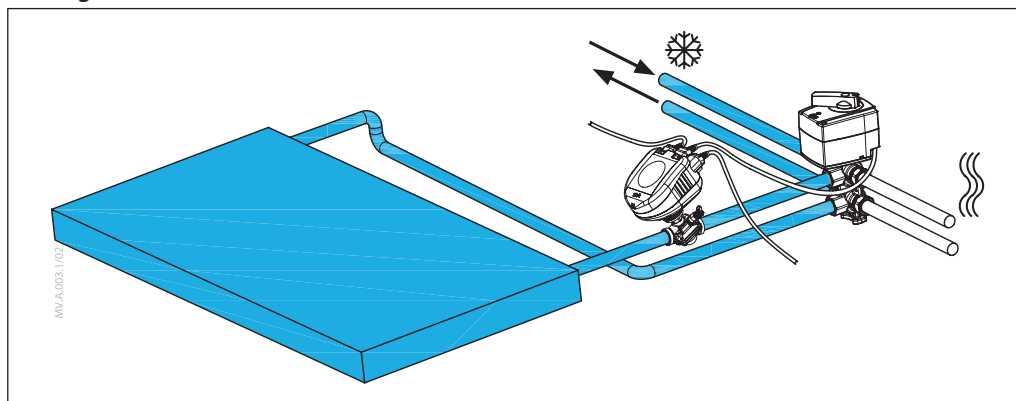

**Heating:**

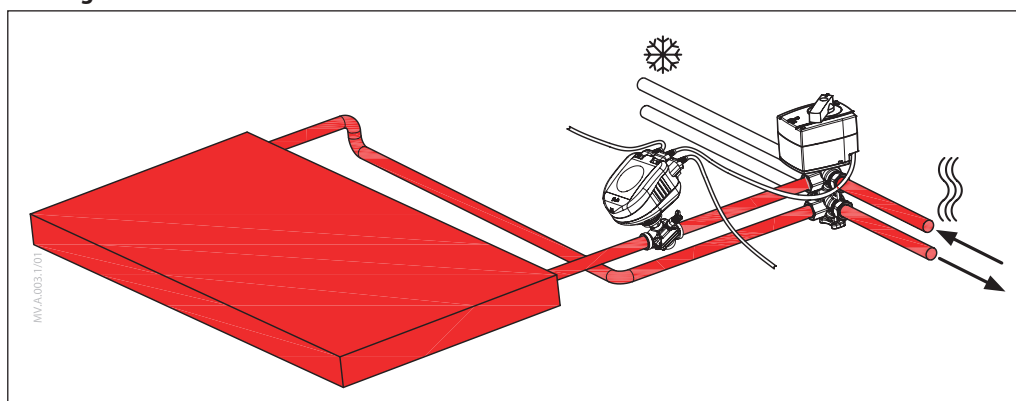

No mixing and shut off

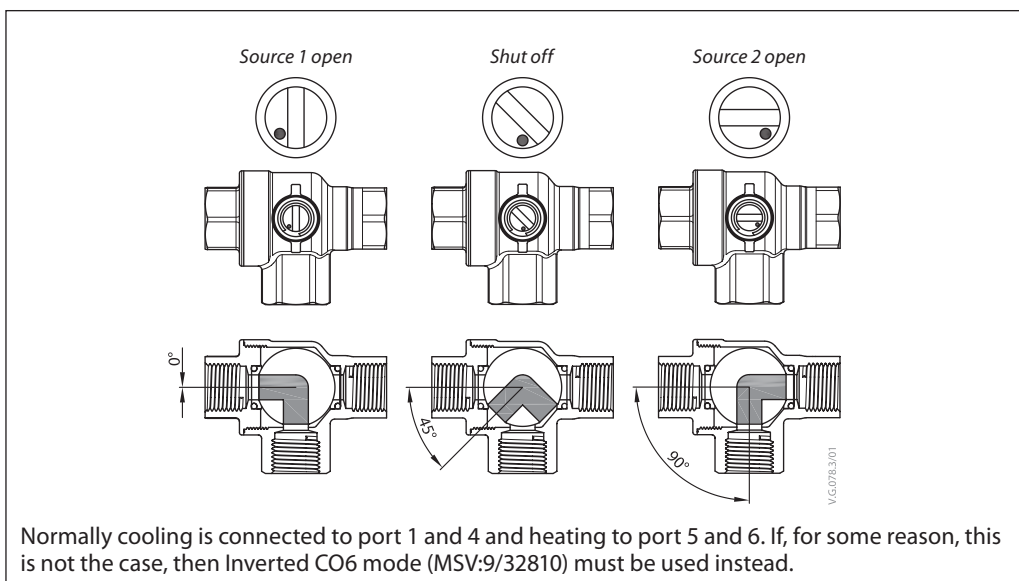

CO6, contrary to other ball valves, includes a shut off function. This function should only be used during maintenance and not during operation. This replaces the need for four ball valves. The Shut off command can only be performed when the Flow Rate Setpoint (AV:1/33280) is 0.

**MSV:9 / 32810 Application mode**

**State 3: CO6 Mode**

Normally cooling is connected to ports 1 and 4 and heating to ports 5 and 6. If that is not possible, then this may be switched and state **4: Inverted CO6 Mode** must be selected.

NovoCon® S and the ChangeOver<sup>6</sup> actuator communicate with voltage control and feedback signal. Whole functionality is available by using simple bus commands. For easier technical understanding, please see below detailed explanation of the communication between NovoCon® S and the ChangeOver<sup>6</sup> actuator.

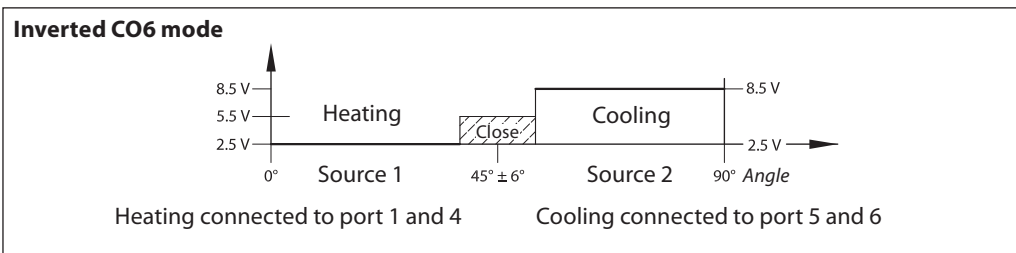
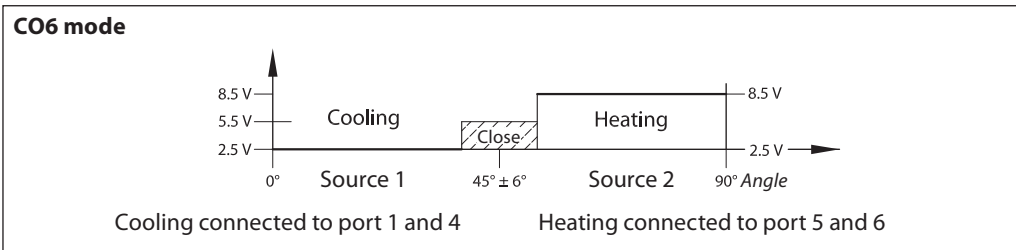

Signal from NovoCon® S to the Actuator NovoCon® ChangeOver<sup>6</sup>

	Stop the motor	Cooling	Shut-off	Heating
CO6 mode	1.0 V	2.5 V	5.5 V	8.5 V
Inverted CO6 mode	1.0 V	8.5 V	5.5 V	2.5 V

Feedback signal from the Actuator NovoCon® ChangeOver<sup>6</sup>

Unable to move	Cooling	Moving direction: Cooling to Heating	Shut-off	Moving direction: Heating to Cooling	Heating
1.0 V	2.5 V	4.0	5.5 V	7.0 V	8.5 V

**Auto baud rate**

NovoCon® S should be connected after, or at the same time as, other BACnet devices. NovoCon® S will then adapt to its network's baud rate automatically.

**Baud rate MSV:6 / 32804 must be set to 1 (default).**

If the NovoCon® S observes activity on the bus within 45 seconds after powering up, then it adopts the baud rate presently used on the network by other BACnet devices. If the actuator does not see activity on the network within this time, it generates a token and sends the token out at the default baud rate of 38400bps.

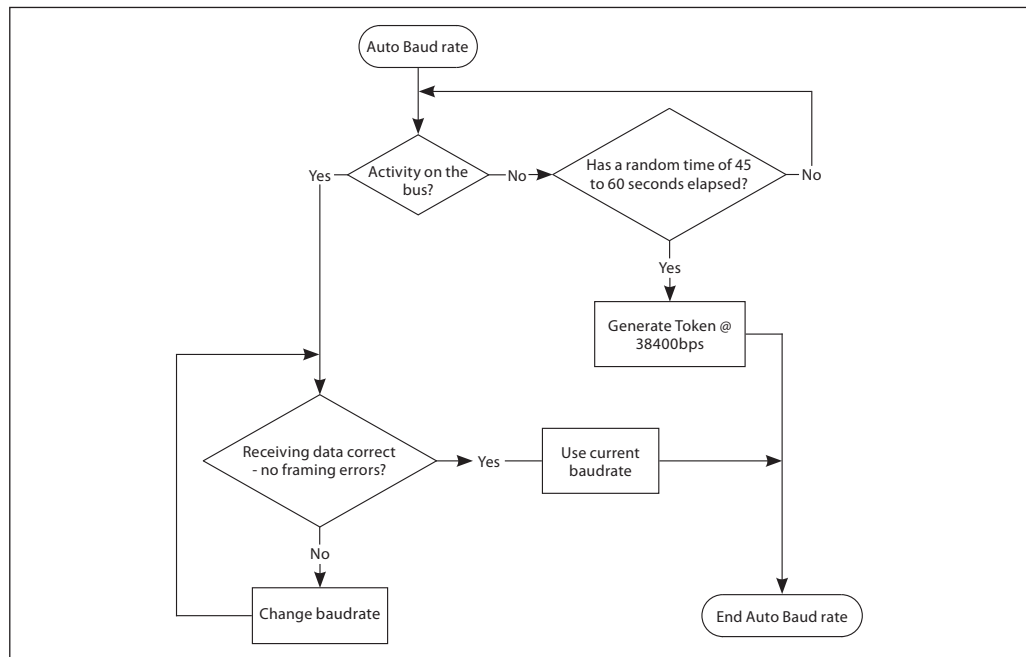

**Auto MAC Addressing  
- BACnet only**

**MAC address assignment method MSV:5 must be set to 1 (default).**

The NovoCon® S actuator observes for used which MAC addresses on the sub-network that are taken and then automatically assign an available MAC address to the actuator on first power up, if the address has not already been manually selected by DIP Switches. If a MAC address collision arises later and Auto MAC addressing is enabled, this function will start the search for an available MAC address again. When an available MAC address is found, an "I-Am" notification will be sent out via BACnet.

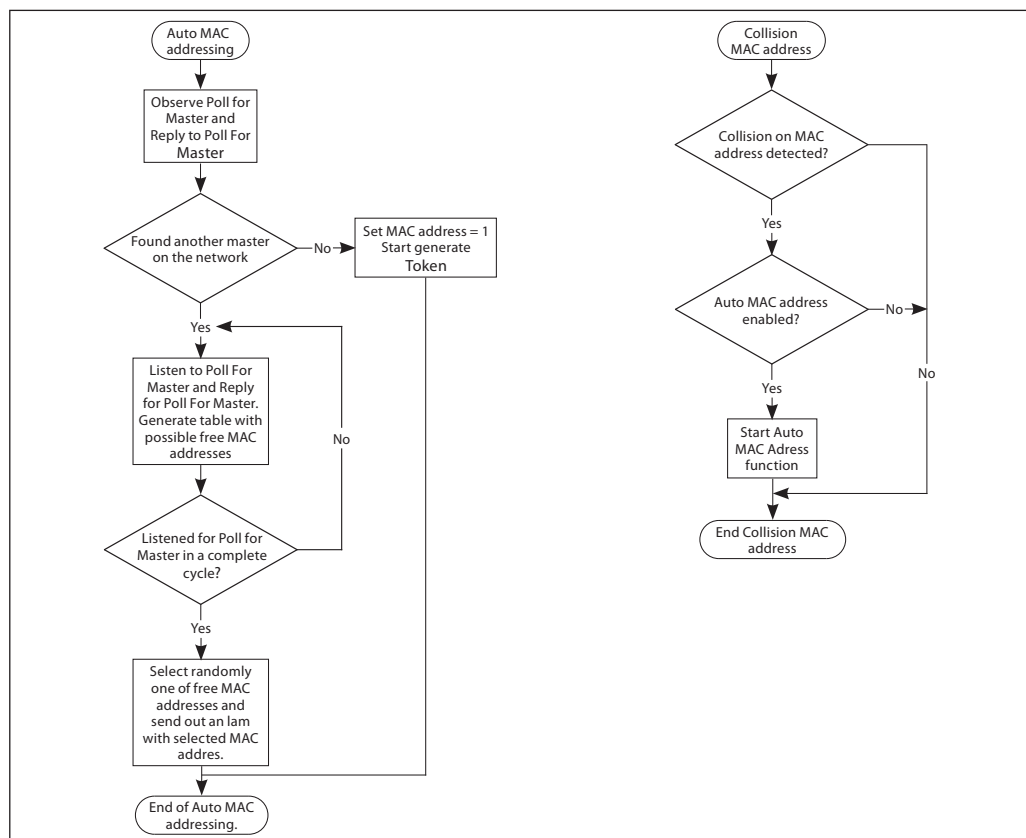



Wiring



The wiring of BACnet MS/TP or Modbus RTU (RS485) must be carried out in accordance with applicable standard ANSI/TIA/EIA-485-A-1998. **Galvanic separation shall be provided for segments crossing buildings. Common ground shall be used for all devices on the same network inclusive router, gateways etc.**

All BACnet bus connections in the cables are made with twisted wires.

The cable type used for NovoCon® analog, digital and I/O cables is AWG22/0.32mm<sup>2</sup>. If other cables are used to extend the length, always use twisted pair wire for bus signal and include ground for the bus signal. The recommended cable type for this is AWG22/0.32 mm<sup>2</sup>. If used for longer distances please use a AWG20/0.5mm<sup>2</sup> or AWG18/0.75mm<sup>2</sup> cable. The cables characteristic impedance shall be between 100-130Ω. The capacitance between conductors shall be less than 100 pf per meter. Note: the length of the cables influence on the communication speed. Longer cable lengths should mean lower baud rate. Maximum cable length allowed is 1200m.

Use a minimum 20 cm distance between 110V/230V/400V power line cables and bus cables.

NovoCon® S has mis-wiring protection on up to 30 V AC/DC on all wires, but be aware that if 30V AC are connected to the Analog input the external power supply will see this as a short circuit and blow the fuse in the external power supply.

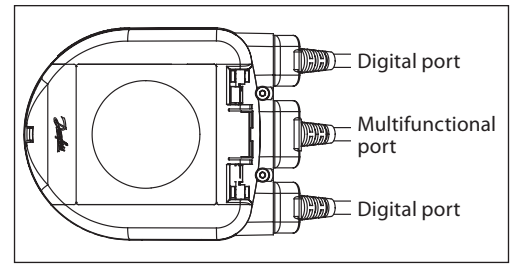

**NovoCon® digital daisy chain cable**

The digital daisy chain cable is used to connect power and BACnet/Modbus between two NovoCon® S devices.

**NovoCon® digital cable**

- Red: Power
- Black: Common ground for power and bus signal wire
- Green: '+' non-inverting signal wire
- Green/White: '-' inverting signal wire

The digital cable is used to connect NovoCon® to other BACnet/Modbus devices. It is also used to connect NovoCon to a longer length of power/communication cable other than standard sales codes.

**NovoCon® analog cable**

- Red: Power
- Black: Power ground
- Grey: Analog input
- Blue: Analog input ground

The analog cable is used to connect power and analog control signal. The analog cable can also be used as a voltage booster for NovoCon® S on the network. The "Power ground" and "Analog input ground" should be connected to the same ground on the Controller.

**Cable NovoCon® Energy with PT1000 surface sensor**

**NovoCon® Energy cable** - PT1000 surface sensors

Wiring (continued)

**Cable NovoCon® Energy with universal PT1000 temperature sensor**

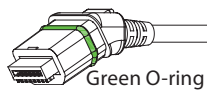

**NovoCon® Energy cable - PT1000 immersed sensors**

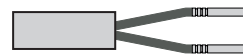

**Cable NovoCon® I/O**

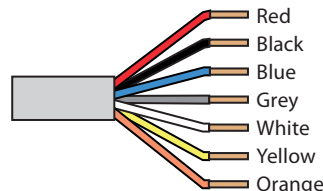
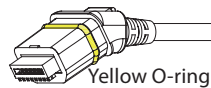

- Red Power 24V (in/out)
- Black Power ground (in/out)
- Blue Ground T1, T2, V/mA input & V output signal
- Grey V/mA input signal
- White V output signal
- Yellow T1 or resistance input
- Orange T2 or resistance input

The red and black wires can be used to boost the power on the line. They may also be used to power external devices, a separate calculation must be made for available power.



To avoid electrical short-circuiting, ensure that loose cable-ends have been connected or isolated before inserting the plug-in connector to the NovoCon® S actuator.

Wiring considerations

The important factors here are:

- Common ground
- 24VDC power supply is recommended
- In case more 24VAC power supplies are used always separate the 24VAC power supplies if different types of power supplies are used and / or different phases are used.

**Wiring with DC power supply: (recommended solution)**

Digital application – 24V DC – PSU with power sharing capability, both on the same or different phases.

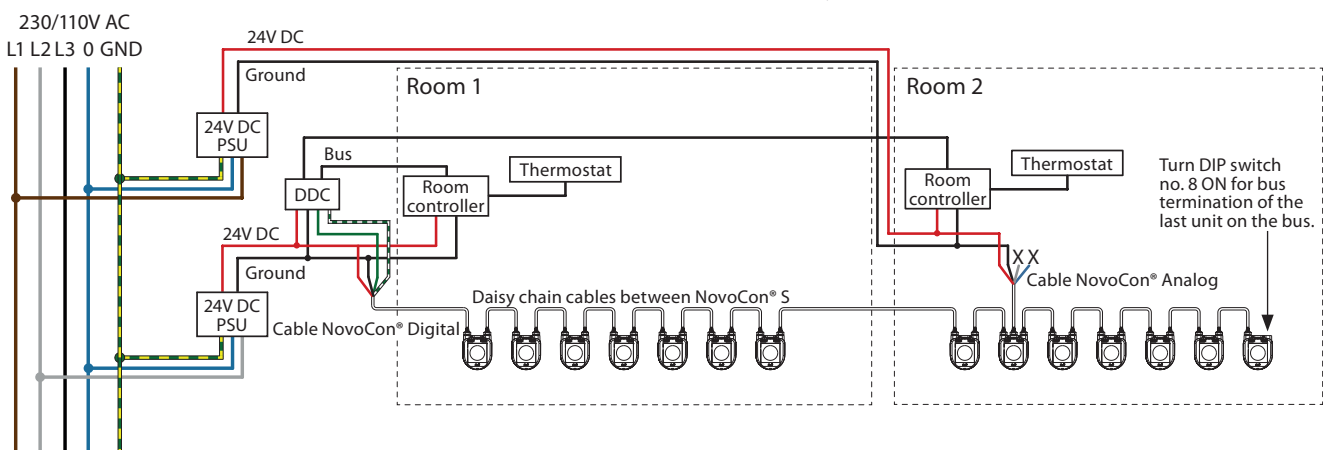

**Wiring with DC or AC power supply:**

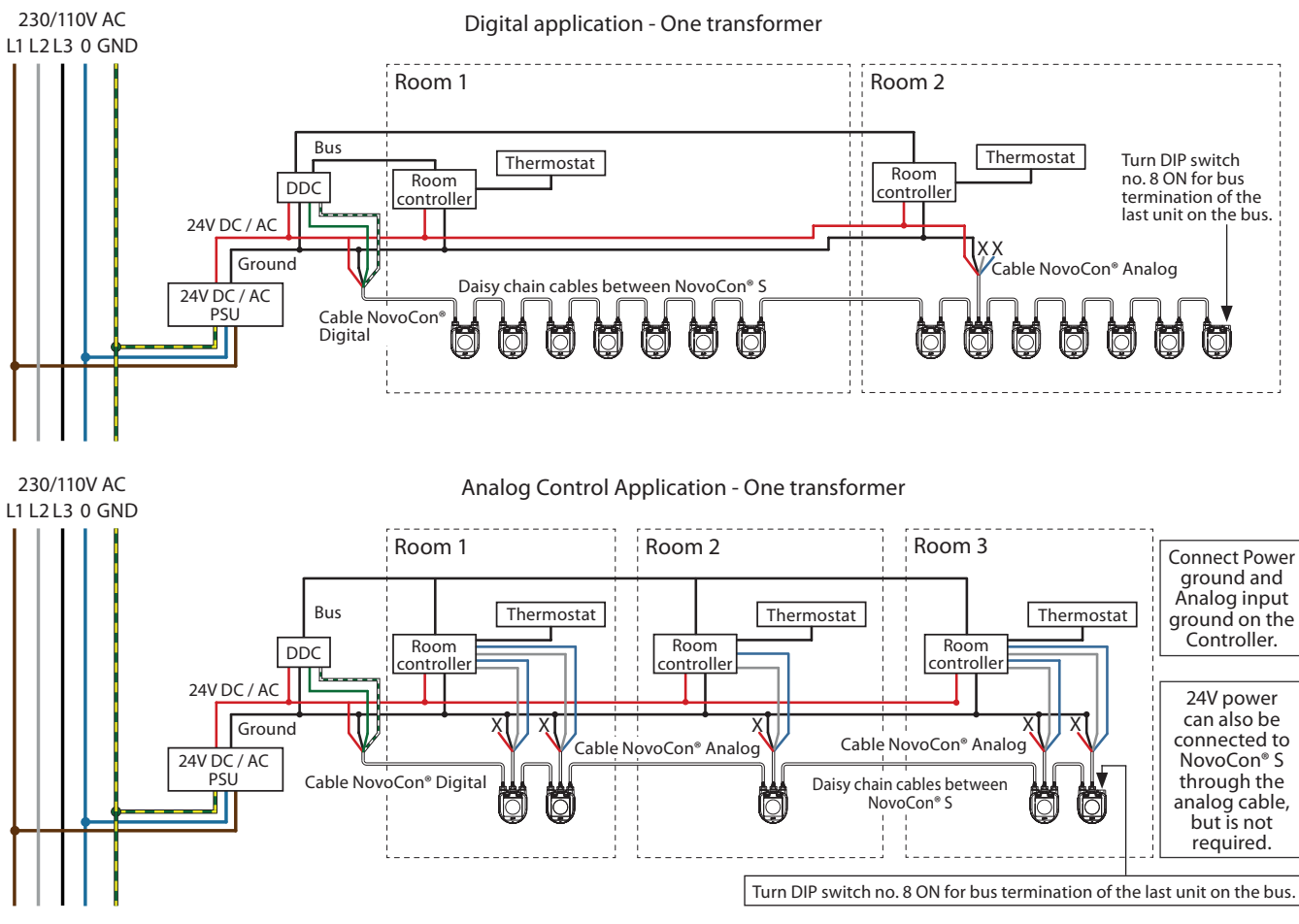

**Wiring with AC power supplies:**

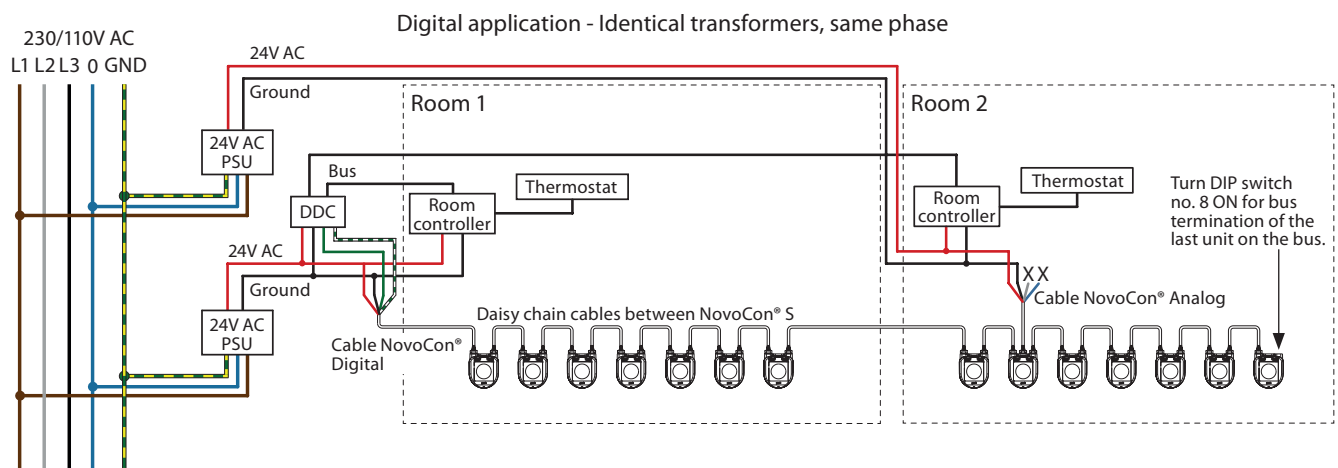

If the NovoCon® S network is supplied with two or more AC power boosters, caution must be observed when disconnecting one of the transformers from the high voltage power line. As the NovoCons are connected in a daisy chain, there may be high voltage on the primary side of the disconnected power supply. Disconnect always both the primary and secondary side of the transformer.

The power boosters must be protected against overload, otherwise the power booster may be damage if one of the other power boosters in the network is disconnected.

Wires that ends in an "X" must be properly terminated.

**Wiring with AC power supply:** (continued)

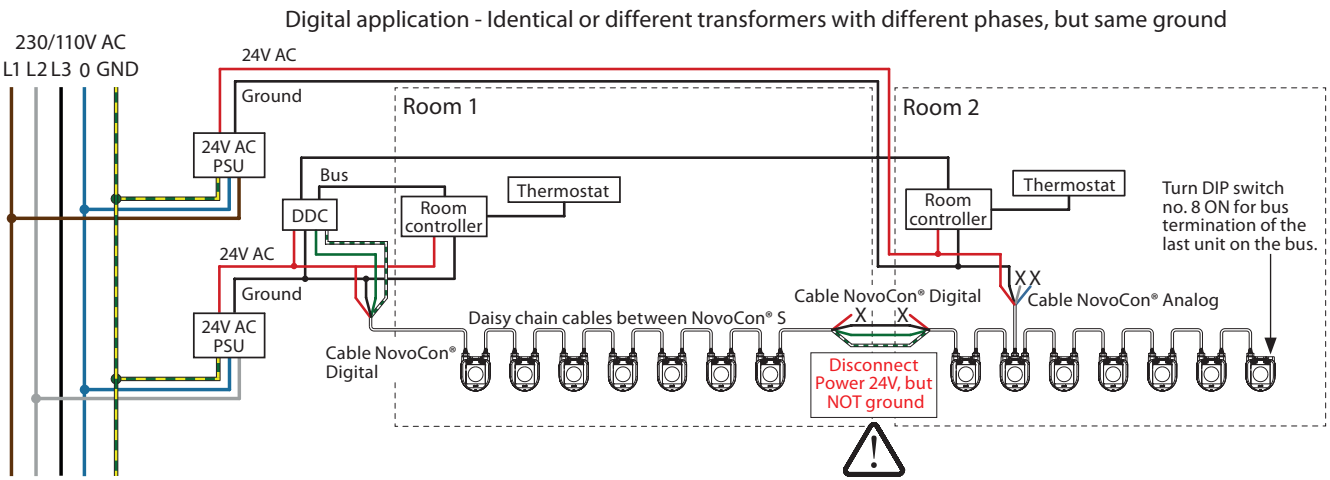

Wires that ends in an "X" must be properly terminated.

**NovoCon® S ChangeOver<sup>6</sup> application**

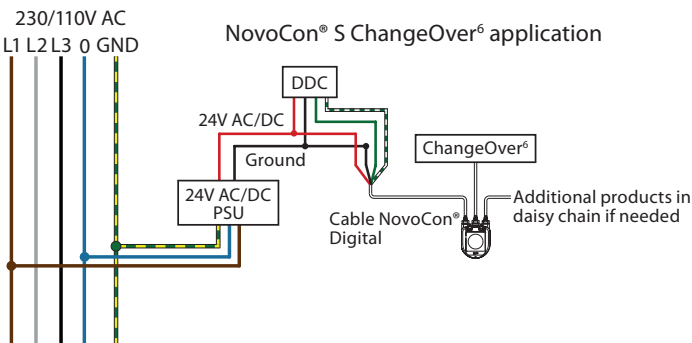

**Wiring I/O application**

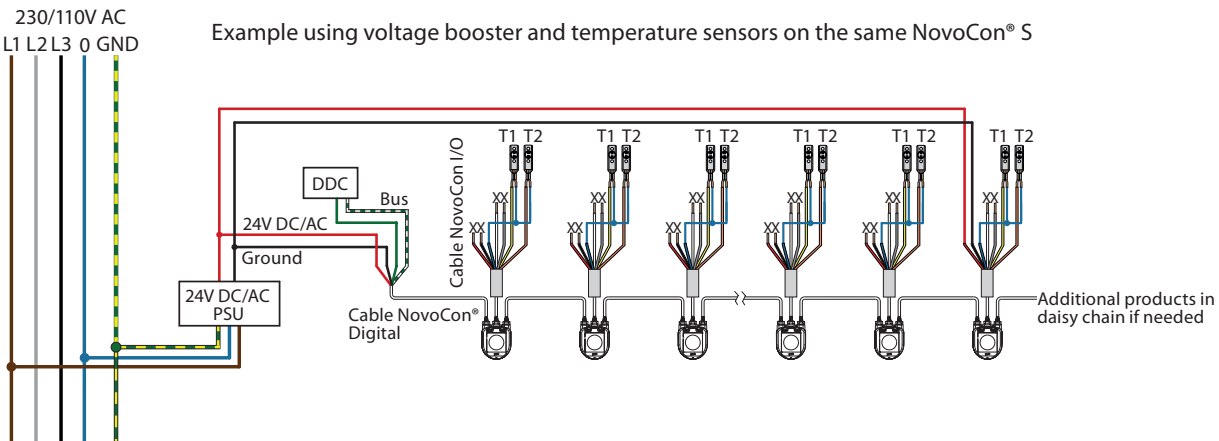



**Daisy chain** *(continued)*

Use daisy chain connection for NovoCon® S. Danfoss recommend that star topology is NEVER used with NovoCon® S as debugging the system becomes very difficult. T-junction connections (stub lines) are not recommended. In the event of T-junction connections being used, Danfoss accepts no responsibility although it is advised that the following limitations are never exceeded:

- max T-junction cable length 1.5m (shortest standard digital cable)
- total length of Network max 640m (+ 100m stub length)
- max baud rate 76 kb/s<sup>1)</sup>
- max number of devices on network 64<sup>1)</sup>
- main cable should be standard RS485 bus, twisted pair, min thickness AWG22 / 0.32mm<sup>2</sup>.

<sup>1)</sup> When using less than 32 devices you may attempt to raise the speed to 115 kb/s.

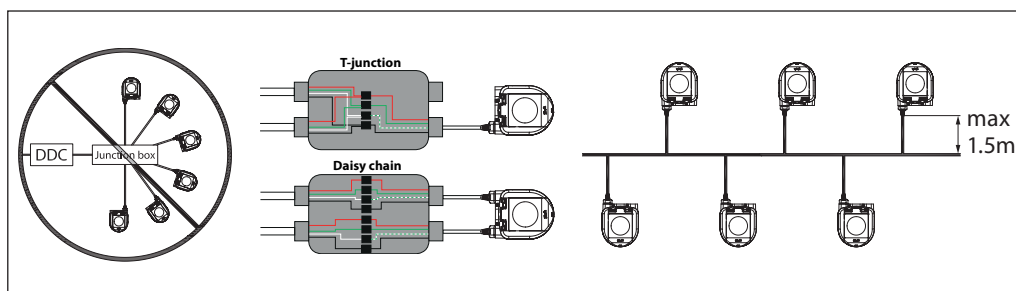

If the supply voltage to the first device in the daisy chain is lower than 24V AC/DC, or long thin cables other than NovoCon® cables are used, then the quantity of devices in the daisy chain may have to be reduced.

The recommended maximum quantities of NovoCon® S are 64 pcs in one daisy chain connection. If other BACnet devices are added with NovoCon® S in the same daisy chain connection, Danfoss recommends a maximum of 32 pcs. to ensure sufficient network speed.

Danfoss recommends that NovoCon® S should be used on its own sub-network for optimal performance.

General requirements and recommendations:

- Use Danfoss daisy chain cable to connect two NovoCon® S devices.
- Use Danfoss digital cable to connect NovoCon® S with another BACnet device.
- The current in cables should not exceed 3Arms at 30°C.
- Use the termination resistor (DIP switch 8) at the end of daisy chain.
- Voltage boosting may be achieved via any port.
- Generally, the same type of power supply is preferred.
- If two power supplies are used, they must have the same polarity and the same common ground.
- A common ground must be used for all devices on the same sub-network, including routers and gateways.
- Galvanic separation shall be provided for segments crossing buildings.
- Total maximum cable length of sub-network 1200m.

**Optimize BACnet network speed**

**Reducing Unnecessary PollforMaster Traffic**

Setting for the last NovoCon® in the daisy chain:

The MAX\_MASTER setting in NovoCon® S shall be set to the number of the highest used MAC address in the MS/TP sub network. The MAX\_MASTER property is found in the Device object and has a default value of 127. It should be noted that the MAX\_MASTER property value should be adjusted accordingly at a later stage if more devices are added to the network and the highest MAC address exceeds the MAX\_MASTER property value.

Before MAX\_MASTER can be set it is needed to ensure all devices are within the MAX\_MASTER value. If MAX:MASTER is set to 20 communication will not work with a device, which uses MAC address 22, even though e.g. MAC address 15 is not used.

**Allocating Correct INFO\_FRAMES**

Setting for Controller:

Network Routers and Controller devices that transport traffic in the MS/TP network require a higher number of INFO\_FRAMES than NovoCon® S. Therefore, these devices should have a higher value than NovoCon® S e.g. A general rule of thumb for the sub network router's MAX\_INFO\_FRAMES property value is equal to the amount of MS/TP devices in the router's sub network. The MAX\_INFO\_FRAMES property is found in the Device object of MS/TP devices. NovoCon's default MAX\_INFO\_FRAMES value is 1.

LED Display

**BACnet/Modbus (RS485) activity**

**BACnet/Modbus (RS485) activity**  
 No light from LED: Actuator sees no activity on the network.  
 LED turn on and off quickly, 10x/second:  
 Normal operation on the network communication is OK.  
 LED turn on and off slowly with green light, 3x/second: Normal operation on the network - communication over longer time directly with this actuator.

**BACnet/Modbus (RS485) activity with ERRORS**  
 LED turns on and off slowly, 3x/second, with RED color: Actuator sees activity, but with errors.  
 LED turn on and off quickly, 10x/second, with RED color: Communication is OK, EXCEPT that another device may be using the same MAC address.

**Position of valve/actuator**

AB-QM valve is **fully closed**.

AB-QM is 1-24% open.

AB-QM is 25-49% open.

AB-QM is 50-74% open

AB-QM is 75-99% open.

AB-QM valve is **fully open**.

**Flush is active**  
 All LEDs turns on/off with specific period.

LED Display (continued)

**Movement of valve/actuator**

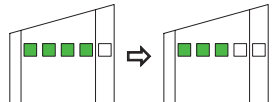

**NovoCon® S is closing the valve**  
All green LEDs are turned ON, then turned OFF one at the time (repeatedly).



**NovoCon® S is opening the valve**  
All green LEDs are turned OFF, then turned ON one at the time (repeatedly).

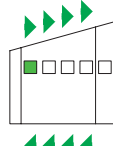

**NovoCon® S is calibrating**  
Green light moves forward and backwards, one by one.

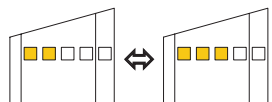

**De-air is active**  
Yellow LEDs are turned ON one by one, then turned OFF one by one (repeatedly).

**Information from actuator**

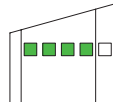

**Blinking function**, all green LEDs turns on/off. Used to physically identify individual actuator on the bus.

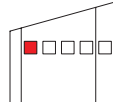

**Error during closing**  
Debris might be trapped under the AB-QM valve cone. Flushing may solve the problem.

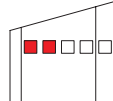

**Temperature inside NovoCon® S is out of the recommended range**  
LEDs change between showing the alarms and showing normal operation. Ambient temperature has likely exceeded 60°C.

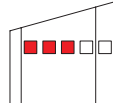

**Internal NovoCon® S error**  
LEDs change between showing the alarms and showing normal between operation. Try:  
A: Re-calibrate.  
B: Turn power off and on.  
C: If the error does not disappear actuator replacement can be necessary.

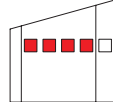

**Error during NovoCon® S calibration**  
LEDs change between showing the alarms and showing normal operation. Verify if the NovoCon® S is correctly attached to the valve and recalibrate.

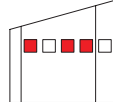

**Power supply is outside limits**  
LEDs change between showing the alarms and showing normal operation. Use analog cables as voltage booster.

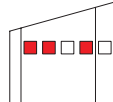

**No Control Signal**  
In analog mode the broken control wire is detected.  
In CO6 mode or Inverted CO6 mode the ChangeOver<sup>6</sup> actuator is not connected or damaged.

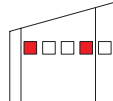

**ChangeOver<sup>6</sup> actuator**  
The ChangeOver<sup>6</sup> actuator is in manual override or unable to reach position.

LEDs change between showing the alarms and showing normal operation.



LED Display (continued)

Pressing the reset button during normal operation

**Calibration/Reset/Flush**  
 Press reset button. All LED's are turned off.  
 Keep pressing the reset button for  
 1 second: 1 LED ON  
 2 seconds: 2 LEDs ON = Start calibration (Reset).  
 3 seconds: 3 LEDs ON  
 4 seconds: 4 LEDs ON = Start flushing.  
 5 seconds or more = Return to normal operation.

**Factory reset - reset to default settings**  
 Press and hold the reset button and then power up the actuator, all LED's are initially turned off.  
 Keep pressing the reset button until 4 LED's are turned on = Reset to default settings.

**When factory reset is performed it is shown by:**  
 1 short flash with all yellow position LED's.  
 Note that after factory reset a calibration will be automatically be performed and all settings are reverted to factory settings.

**BACnet objects and Modbus registers usage**  
 - Design flow rate setting

**General**

There are simple BACnet and Modbus settings that are essential to the basic setup configuration of NovoCon® S in order to communicate and control. These are contained in the BACnet objects or in decimal format Modbus registers.

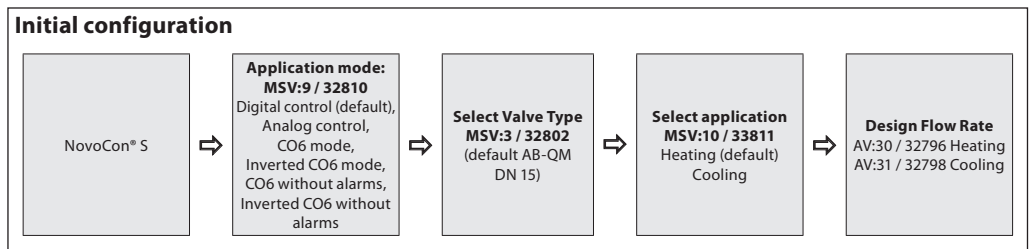

**BACnet objects and Modbus registers usage**  
 - Advanced configuration and features

If the default setup of the actuator isn't suitable, special attention has to be payed to the following objects:

MSV:9 / 32810	Application mode
MSV:3 / 32802	Selected Valve Type
AV:30 / 32796	Design Flow Rate Heating
AV:31 / 32798	Design Flow Rate Cooling
MSV:10 / 33811	Application command & status
AI:1 / 32791	Temperature T1 or resistance input
AI:2 / 32792	Temperature T2 or resistance input
AV:32 / 33288	Power Emission
MSV:13 / 32814	Energy management

**Application mode:**

The default Application mode is Digital Control. In this mode the NovoCon® S is controlled via fieldbus and the the voltage inputs and outputs are available to connect other devices.

If the CO6 functionality is needed the Application mode must be changed to CO6 mode. This is where the NovoCon® S actuator is ready to be used with the Actuator NovoCon® ChangeOver®. If the heating and cooling pipes are connected inverted to that shown on the data sheet, then CO6 Inverted mode must be selected. The object/register MSV:9 / 32810 Application mode is used to select this. Analog Control is also possible if required.

Select if the application is Heating, Cooling or CO6 in Application command & status MSV:10 / 33811.

**Selection of AB-QM valve type:**

After selecting Application mode (see above), it is then necessary to select the AB-QM valve type that the actuator is mounted on. This is done with the object MSV:3 / 32802 Selected Valve Type. The present value of MSV:3 / 32802 may be set to values between 1 and 17. Each number represents a specific AB-QM valve type, which can be found in the table: Valve type selection. The default value for MSV:3 / 32802 is 4 i.e. ABQM ISO DN15 valve.

**Selection and setting of engineering units:**

If there is a need to change the default engineering units, this is done in BACnet via the object's engineering units property or in separate objects, and in Modbus via separate registers. Se the BACnet and Modbus tables for more details.

**BACnet objects and Modbus registers usage**

**- Advanced configuration and features** *(continued)*

**Setting the Design Flow Rate:**

Now we come to the point where the designed maximum flow rate of the controlled system should be set if the nominal flow of the valve does not correspond to the designed maximum flow rate. The Design Flow Rate is set by changing the present value of:

- MSV:30 / 32796 Design Flow Rate for Heating
- MSV:31 / 32798 Design Flow Rate for Cooling

Note: If the Design Flow Rate is set to more than the nominal flow value of the valve, the mechanical pre-setting on the valve must be set to maximum open i.e. fully opening the mechanical pre-setting wheel on the AB-QM valve (100% open is the default mechanical pre-setting from our factory).

**Changing from Heating to cooling in CO6 and Inverted CO6 mode:**

The object / register MSV:10 / 32811 CO6 command & status is used to change from heating function to cooling function as well as giving feedback as to the ball position status. A more detailed description of this is found in the tables for BACnet objects / Modbus registers.

**Temperature measurements:**

AI:1 / 32791 Temperature T1 or resistance input and AI:2 / 32792 Temperature T2 or resistance input are used to measure the temperature with PT1000 temperature sensors. The resistance value may also be show directly if selected, allowing these inputs to be used for other purposes than measuring temperature e.g. window contacts or another potential free contacts. Closed circuit <900Ω, open circuit >10kΩ.

**Power emission:**

AV:32 / 33288 Power Emission is used to show the present hydronic power emission of the terminal unit, based on calculations from water flow rate and the temperature difference between supply and return pipes.

**Energy Counter:**

Both the Cooling and Heating hydronic energy used are counted and logged under AV:33 / 33290 and AV:34 / 33292. This function is enabled and disabled with MSV:12 / 32813.

**Flushing a system:**

Actuator Mode and Special Features MSV:0 / 33284 has an option which allows the user to flush the system via the field bus. To start flushing the system, set MSV:0 / 33284 to 3, Flush. The actuator will then open up the AB-QM valve completely. Flush will end when:

- MSV:0 / 33284 is set back to 1 = Normal operation
- Power is cycled.
- Or flush function times-out after 1 hour.

When flushing ends, the actuator returns to normal operation.

**De-Airing of a system:**

With MSV:0 / 33284, is it also possible to start the De-Air function in the actuator. This function will open and close the AB-QM valve a number times, helping getting rid of trapped air in the hydronic system. Start De-Air by setting MSV:0 / 33284 to 4. De-air will run undisturbed until it ends. The state of the actuator will then go back to normal operation i.e. MSV:0 / 33284 = 1, Normal.

**Controlling the actuator:**

Under normal operation Digital (MSV:9 / 32810 Application mode in CO6 mode, Inverted CO6 mode and Digital mode) of the actuator, where the flow through the AB-QM valve is to be controlled, the object Flow Rate Setpoint AV:1 / 33280 is used. The default setting for the Flow Rate Setpoint engineering unit is %.

This is the most suitable setting as the controller does not need to know anything about the Design Flow Rate setting of the actuator. The output signal from the controller needs only to be set up so it regulates from 0 to 100% of the Heating Design Flow Rate AV:30 / 32796 or Cooling Design Flow Rate AV:31 / 32798. Alternative Design Flow Rate AV:0 / 32768 can be used.

To change the flow rate through the valve, the present value of AV:1 / 33280 is written-to, in the range 0 – 100%.

If the engineering unit selected for AV:1 / 33280 must be l/h, the Flow Rate Setpoint through the valve must be written-to in integers representing l/h. An example of this could be a controller writing values to the actuator in the range 0 to 450 l/h for a DN15 valve.

**Alarms and warnings:**

System issues can be detected by using BACnet object values BV:10 to BV:24 or Modbus register 33536, see BACnet and Modbus tables for more details.

MSV:9 / 32810 has also a state called "CO6 without alarms" meaning that essentially the same CO6 functionality is present (2 Design flows and the changeover signal) without alarms, so the analog input signal may be used to connect other devices if required.

**Energy management**  
MSV:13 / 32814

**State 1: Not active**  
Energy management applications are disabled.

**Power Manager**

**State 2: Power limitation (cooling water example)**  
NovoCon® S calculates the instantaneous hydronic power used and will then override the DDC control signal and limit the flow rate / hydronic power according to the user defined values in object / register AV:35 or 36 / 32832 or 32834. The hydronic power is limited by closing the valve until the kW value measured, once again, falls below the defined limit. There are user defined limits for both Cooling Power and Heating Power. When this limitation is active, the warning object BV:23 / bit 23 in register 33536 will be set to 'on'.  
Application example: When the "Power" is limited in this way we are able to prevent over consumption (during peak load) and save money.

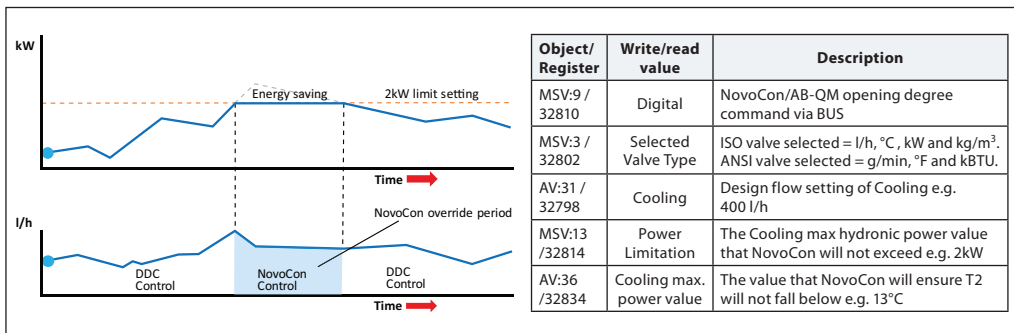

**Power Manager**

**State 3: Power control**  
Emission is controlled directly in kW or kBTU and not % or l/hr / GPM. The flowrate through the valve is controlled by the Flow Rate setpoint AV:1 in kW or kBTU/h (selected in MSV:21 / 32788) and is based on the flowrate and temperature inputs which are used to calculate the power consumption.  
Application example: Tempering a space (e.g. in storage hall) where we can set and keep the energy output constant.

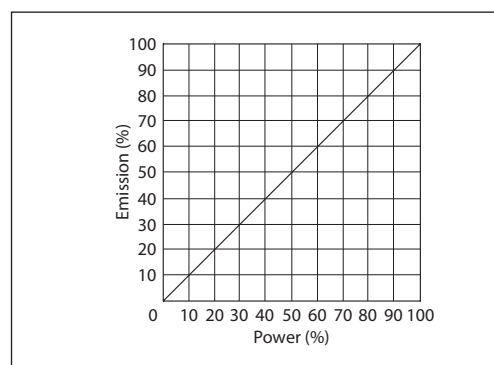

**Delta T Manager**

**State 4: Min. Delta T limitation (heating water example)**  
NovoCon® S overrides the DDC control signal and maintains a minimum temperature difference between the flow and return temperatures by closing the valve when the user defined minimum delta T is not achieved. As the flow temperature increases/decreases, so will the calculated minimum set-point for the return temperature. This always ensures a minimum energy transfer to the FCU irrespective of the flow temperature. This state may also be used in CO6 mode and will apply the appropriate value whilst in cooling/heating mode.  
The delta T value is set in object / register AV:37 / 32836 and/or AV:38 / 32838. When this limitation is active, the warning object BV:23 / bit 23 in register 33536 will be set to 'on'.  
Application example: When we would like to improve the efficiency of boiler/chiller we can define the Minimum Delta T in the system.

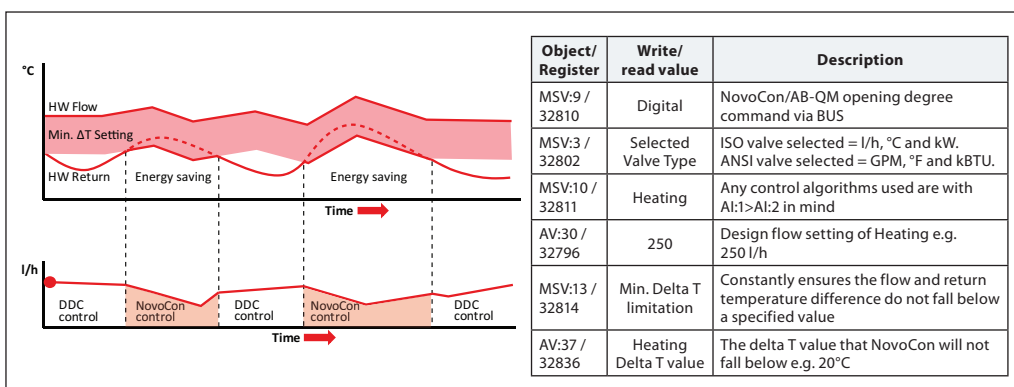

**Energy management**

MSV:13 / 32814 (continued)

**State 4: Min. Delta limitation (Colling water example)**

Application example: When we would like to improve the efficiency in the system we can define the Minimum Delta T in the system.

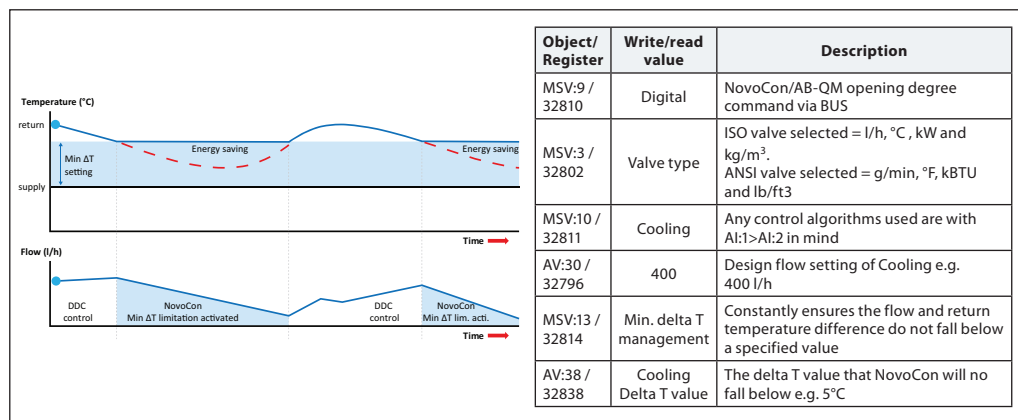

**State 5: Set Delta T control (heating water example)**

NovoCon® S overrides the DDC control signal and maintains a constant temperature difference between the flow and return temperatures by opening and closing the valve when the user defined delta T is exceeded or not achieved. When the flow temperature increases/decreases, so will the calculated delta T set-point for the return temperature. This always ensures a constant delta T across the FCU irrespective of the flow temperature. This state may also be used in CO6 mode and will apply the appropriate value whilst in cooling/heating mode.

The constant delta T is set in object / register AV:37 / 32836 and/or AV:38 / 32838.

Application example: Tempering a space (e.g. in storage hall) where we can set and keep a constant Delta T.

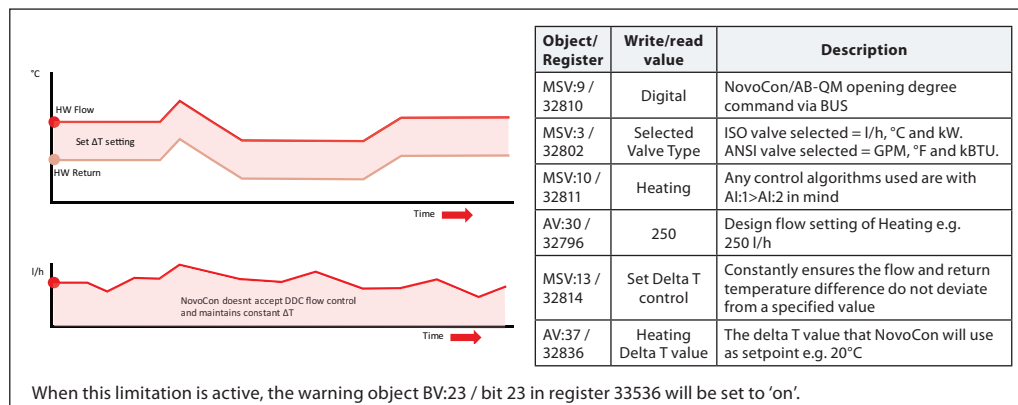

**State 6: Min. Return T limitation (cooling water example)**

NovoCon® S ensures the min. return temp. which is set in register / object AV:40 / 32842.

This function will mainly be used for a Cooling application where the return temperature is higher than the flow temperature. NovoCon® S overrides the DDC control signal and maintains a minimum return temperature closing the valve when the user defined minimum return temperature is not achieved.

When this limitation is active, the warning object BV:23 / bit 23 in register 33536 will be set to 'on'.

Application example:

To improve chiller efficiency and ensure proper flow temperature for cooling systems, we can prescribe minimum return temperature to avoid COP dropping and low Delta T syndrome.

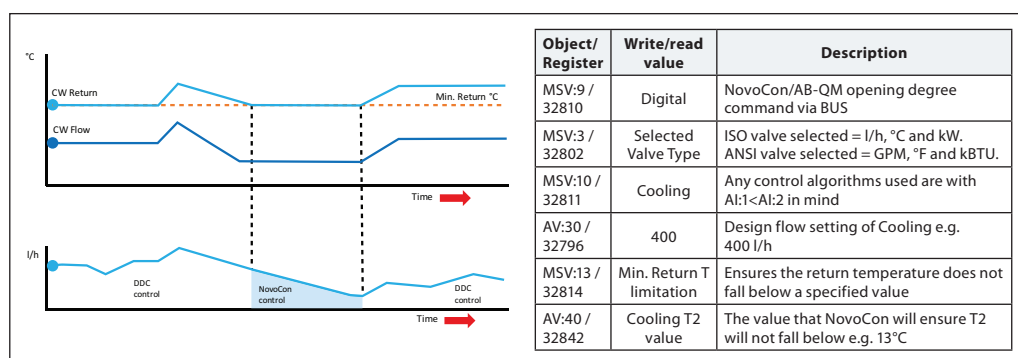

**Energy management**  
**MSV:13 / 32814** (continued)

**State 7: Max. Return T limitation (heating water example)**

NovoCon® S ensures the max return temp. set in register / object AV:39 / 32840. This function will mainly be used for a Heating application where the return temperature is lower than the flow temperature. NovoCon® S overrides the DDC control signal and maintains a maximum return temperature closing the valve when the user defined maximum return temperature is not achieved. When this limitation is active, the warning object BV:23 / bit 23 in register 33536 will be set to 'on'. Application example: Free cooling (e.g. river based) application where we would like to avoid river overheating.

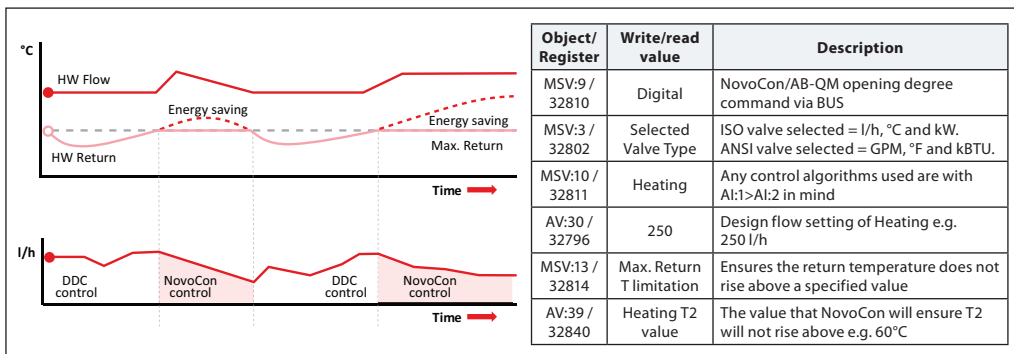

**State 8: Set Return T control (heating water example)**

A constant return temperature T2 value is set in object / register AV:37 / 32836 and/or AV:38 / 32838. NovoCon® S overrides then the DDC control signal and maintains a constant return temperature by opening and closing the valve when the user defined Return T is exceeded or not achieved. When the flow temperature increases/decreases, the Return T set-point remains the same. This will ensure a constant return temperature back to the boiler/chiller if all terminal units (Fan Coils, radiant panels etc.) are set with the same parameters. Application example: When we intend to use the return water for secondary usage (e.g. floor heating) with constant inlet temperature, worth to set constant return temperature of the primary heating water.

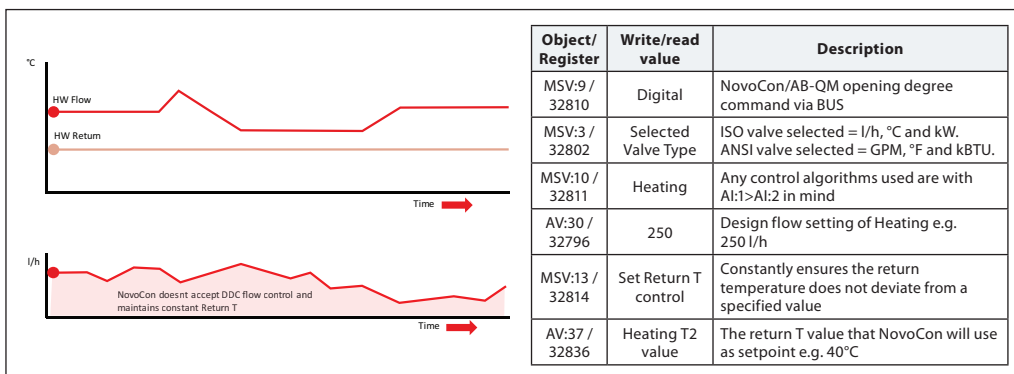

BACnet Objects - Analog Value

Ident	Object / Parameter name	Unit	Read/ Write	Min	Max	Default	Resolution	Description	Persistent Yes/No
AV:0	Design Flow Rate	98: % 136: L/h 89: GPM	R/W	Recommended 20% of nominal flow	Setting Range Maximum from Valve table	Nominal value from the Valve table in L/h	0.1	Recommended to use AV:30 for Heating and/or AV:31 for cooling. Pre-set value for the Design Flow Rate when control signal is at 100%, if the Application mode is Analog or Digital control otherwise not used. Units can be changed via the object's engineering units property and/or MSV:20. The units L/h (ISO valves) or GPM (ANSI valves) comes from the object MSV:3 Selected Valve type.	Yes
AV:1	Flow Rate Setpoint	98: % 136: L/h 89: GPM 48: kW 157: kBTU/h	R/W	0	100% or Design Flow value	100%	0.01	The Flow Rate Setpoint (max. flow rate) through the AB-QM valve. Units can be changed via the object's engineering units property and/or MSV: 21. NOTE: For kW or kBTU/h to become active, MSV:13 Power Controller (state:3) must be chosen.	No
AV:2	Actual Flow Rate feedback	%, L/h, GPM	R	0	If L/h (GPM) is selected then the valve flow rate is set to the selected valve's (MSV:3) maximum value. Otherwise 100%	L/h or GPM depending on the selected valve	0.001	Flow rate indication based on the position of the Actuator stem. Units can be changed via the object's engineering units property and/or MSV:22. This object is supported by COV.	No
AV:3	Control fallback Time	72: Minutes	R/W	0	60	10	1	Time before actuator reacts to a missing analog control signal. i.e. when MSV:9=1 Analog control and not receiving an analog control signal.	Yes
AV:4	Alpha Value	95: No units	R/W	0.05	1.0	1,0	0.01	Value used for shaping the curve in Manual Defined Function (MDF) mode to fit the characteristic curve of a heat exchanger. Linear setting: MDF=1. See curve below table. If AV:1 is in L/h in Digital mode, the alpha setting is ignored. See Alpha value diagram.	Yes
AV:5	Valve closing or opening time	73: Seconds	R/W	18	700	na	1	The time the actuator needs to move from 0% to 100% of Design Flow Rate. Use with MSV:4.	Yes
AV:6	Rectified voltage measured by the actuator	Volts	R	12	50	na	0.01	Rectified voltage which powers the actuator. Too low voltage: 16.1-17.5V. Too high voltage: 38.3-43.4V. Use to check power booster numbers a layout.	No
AV:7	MAC Address	95: No units	R/W	1	126	na	1	MAC Address used for BACnet communication.	Yes
AV:8	Temperature in the Actuator	°C, °F	R	-20	100	°C	0.5	Temperature measured inside the actuator. Units can be changed via the object's engineering units property.	No
AV:9	Total Operating Hours	Hours	R	0	MAX	na	1	Total Operating Hours of the actuator.	Yes
AV:10	Minutes since last power-up	Minutes	R	0	MAX	na	1	Minutes since the last power-up of the actuator.	No
AV:11	Minutes since last calibration	Minutes	R	0	MAX	na	1	Minutes since the last time the actuator was calibrated to an AB-QM valve.	Yes
AV:12	Minutes since fully closed	Minutes	R	0	MAX	na	1	Minutes since the last time the AB-QM valve was fully closed.	Yes
AV:13	Minutes Since fully Opened	Minutes	R	0	MAX	na	1	Minutes since the last time the AB-QM valve was fully opened.	Yes
AV:14	Lifetime estimate	na	R	0	MAX	na	0.01	Calculated percentage of expended lifetime. At 100% the valve and actuator have reached the estimated minimum lifetime. Replacement of valve and actuator is recommended.	Yes
AV:15	Server Message Count	na	R	0	MAX	na	1	Server Message Count	No
AV:16	Server Message Received	na	R	0	MAX	na	1	Server Message Received	No
AV:17	Server Error Count	na	R	0	MAX	na	1	Server Error Count	No
AV:18	Server Message sent	na	R	0	MAX	na	1	Server Message sent	No
AV:19	Server Timeout Error	na	R	0	MAX	na	1	Server Timeout Error	No
AV:20	Serial Number of the actuator	na	R	na	na	na	1	Description of this object holds the serial number of the actuator - programmed at the time of production.	na
AV:21	The name of the Selected valve is shown here	L/h or GPM, Unit type comes from MSV:3 Selected Valve Type	R	na	na	na	1	Nominal flow of the selected AB-QM valve type.	na
AV:22	Valve position at nominal flow	Millimetre	R	na	na	na	1	Position in mm for nominal flow of the selected AB-QM valve.	na
AV:23	Maximum value for the Design Flow Rate	%	R	na	Setting Range Maximum from Valve table	%	1	Maximum level the Design Flow Rate can be increased to for the selected AB-QM valve.	na
AV:24	The name of the User Defined Valve is shown here	136: L/h or 89: GPM. Unit type written here is copied to the Valve Table. Default: L/h	R/W	1	5000	450	0.1	Name and Nominal Flow for the User Defined Valve. This Object is used only if NovoCon® S is not used with an AB-QM valve. Please contact your Danfoss representative to verify if the desired connection is possible.	Yes
AV:25	Valve position at nominal flow for User Defined Valve	30: Millimetre	R/W	1.5	5.8	2.25	0.01	Position in mm for nominal flow of the User Defined Valve. This Object is used only if NovoCon® S is not used with an AB-QM valve. Please contact your Danfoss representative to verify if the desired connection is possible.	Yes
AV:26	Maximum value for the Design Flow in the User Defined Valve	98: %	R/W	100	150	120	1	Maximum level the Design Flow can be increased to for the User Defined Valve. This Object is used only if NovoCon® S is not used with an AB-QM valve. Please contact your Danfoss representative to verify if the desired connection is possible.	Yes
AV:27	Alarm summary count	95: No units	R	na	na	0	na	Numerical overview about pending errors detected. Coding for AV:27 Alarm summary count is: If BV:10 is active then AV:27 is 1.0. If BV:11 is active then AV:27 is 2.0. If BV:12 is active then AV:27 is 4.0. If BV:13 is active then AV:27 is 8.0. If BV:14 is active then AV:27 is 16.0. If BV:15 is active then AV:27 is 32.0. If BV:16 is active then AV:27 is 64.0. If BV:17 is active then AV:27 is 128.0. If BV:18 is active then AV:27 is 256.0. If BV:19 is active then AV:27 is 512.0. If BV:20 is active then AV:27 is 1024.0. If BV:21 is active then AV:27 is 2048.0. If BV:22 is active then AV:27 is 4096.0. If BV:23 is active then AV:27 is 8192.0. If BV:24 is active then AV:27 is 16384.0. e.g. if both BV:11 & BV:12 are active then AV:27 is 6.0. This object is supported by COV.	No
AV:30	Heating Design Flow Rate	98: % 136: L/h 89: GPM	R/W	Recommended 20% of nominal flow	Setting Range Maximum from Valve table	Nominal value from the Valve table in L/h	0.1	Pre-set value for the Design Flow Rate in heating mode, when the control signal is at 100%. The units L/h (ISO valves) or GPM (ANSI valves) comes from the object MSV:3 Selected Valve type	Yes
AV:31	Cooling Design Flow Rate	98: % 136: L/h 89: GPM	R/W	Recommended 20% of nominal flow	Setting Range Maximum from Valve table	Nominal value from the Valve table in L/h	0.1	Pre-set value for the Design Flow Rate in cooling mode, when the control signal is at 100%. The units L/h (ISO valves) or GPM (ANSI valves) comes from the object MSV:3 Selected Valve type.	Yes
AV:32	Power emission	48: kW 157: kBTU/h	R	0	na	kW	0.01	The hydronic power emission of the terminal unit, based on calculations from water flow rate and the temperature difference between supply (AI:1) and return (AI:2) pipes. Units can be changed via the object's engineering units property.	No

BACnet Objects - Analog Value (continued)

Ident	Object / Parameter name	Unit	Read/Write	Min	Max	Default	Description	Information	Persistent Yes/No
AV:33	Heating Energy counter	19: kWh 126: MJ 147: kBTU	R/W	0	na	19: kWh	Accumulative Energy counter for heating.	Activated/Deactivated via MSV:12. Units set via MSV:27	Yes
AV:34	Cooling Energy counter	19: kWh 126: MJ 147: kBTU	R/W	0	na	19: kWh	Accumulative Energy counter for cooling.	Activated/Deactivated via MSV:12. Units set via MSV:27	Yes
AV:35	Heating max. Power	48: kW 157: kBTU/h	R/W	0	na	48: kW	Pre-set value for the design flow rate, in heating mode.	When using MSV:13 state Power limiter this is the maximum allowed hydronic energy output. This value is intended to limit the heating power through the terminal unit.	Yes
AV:36	Cooling max. power	48: kW 157: kBTU/h	R/W	0	na	48: kW	Pre-set value for the design flow rate, in cooling mode.	When using MSV:13 state Power limiter this is the maximum allowed hydronic energy output. This value is intended to limit the cooling power through the terminal unit.	Yes
AV:37	Heating Delta T	62: °C 64: °F	R/W	na	na	62: °C	Set value for Delta T	For MSV:13 state Min. delta T management and Set Delta T control, this is the value the control is based on for heating.	Yes
AV:38	Cooling Delta T	62: °C 64: °F	R/W	na	na	62: °C	Set value for Delta T	For MSV:13 state Min. delta T management and Set Delta T control, this is the value the control is based on for cooling.	Yes
AV:39	Heating T2	62: °C 64: °F	R/W	na	na	62: °C	Set value for Heating T2 (Heating return)	For MSV:13 state Max. Return T management and Set return T control, this is the value the control is based on for heating.	Yes
AV:40	Cooling T2	62: °C 64: °F	R/W	na	na	62: °C	Set value for Cooling T2 (Cooling return)	For MSV:13 state Min. Return T management and Set return T control, this is the value the control is based on for cooling.	Yes

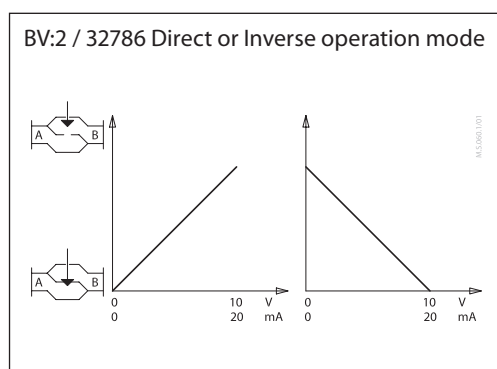
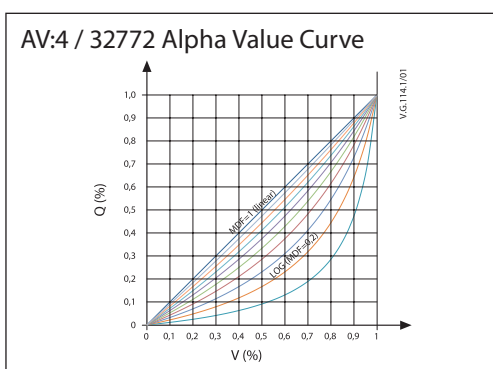

BACnet Objects - Multi State Value

Ident	Object / Parameter name	Read/Write	State Text	Default State	Description	Persistent Yes/No
MSV:0	Actuator Mode and special features	R/W	1: Normal 2: Calibration 3: Flush <sup>1)</sup> 4: De-Air <sup>2)</sup> 5: Alarm	1: Normal	Shows present mode of actuator. Calibration, flushing and de-air may be started from here.	Yes, except state 3,4 & 5
MSV:1	Analog Control signal type and range	R/W	1: 0-5 VDC 2: 0-10 VDC 3: 2-10 VDC 4: 5-10 VDC 5: 2-6 VDC 6: 6-10 VDC 7: 0-20 mA 8: 4-20 mA	2: 0-10 VDC	Used to select the analog control signal input type and range.	Yes
MSV:2	Missing Control Signal Falback Action	R/W	1: No action 2: CLOSE 3: OPEN 4: 50% of Design Flow	1: No action	The action that the actuator will commence upon a missing analog control signal when MSV:9=1.	Yes
MSV:3	Selected Valve Type	R/W	See table "Valve Type Selection"	4: AB-QM DN 15	This is the AB-QM valve type that the actuator is set-up to control.	Yes
MSV:4	Actuator Speed	R/W	1: 3 sec/mm 2: 6 sec/mm 3: 12 sec/mm 4: 24 sec/mm 5: Constant Time	4: 24 sec/mm	The amount of time the actuator takes to move 1mm or alternatively, a specified constant time function (see AV:5). The Constant Time value range is 18-700 seconds.	Yes
MSV:5	MAC Address assignment method	R/W	1: DIP Switch Settings or Auto Addressing 2: User configuration over BACnet or Auto Addressing	1: DIP Switch Settings or Auto Addressing	The MAC address selection method. If the MAC address is not set by DIP Switch, the actuator will automatically assign itself an available MAC address.	Yes
MSV:6	Baud Rate	R/W	1: Auto Baud Rate Detection 2: 9600 bps 3: 19200 bps 4: 38400 bps 5: 57600 bps 6: 76800 bps 7: 115200 bps	1: Auto Baud Rate Detection	Baud Rate used for BACnet communication.	Yes
MSV:7	LED Control	R/W	1: Normal LED mode 2: Show alarms only 3: All LED'S OFF 4: Blink	1: Normal LED mode	The LED display options.	Yes
MSV:8	Select field bus protocol	R/W	1: DIP switch 2: BACnet 3: Modbus	1: DIP switch	Selection of field bus protocol. See also the DIP Switch Settings section of the data sheet. When the protocol is changed, a power cycle is required to make the actuator adopt the newly selected protocol.	Yes

<sup>1)</sup> Opens the valve fully for one hour or until a new state is selected

<sup>2)</sup> Opens and closes the valve 5 times at maximum speed

**BACnet Objects**  
- Multi State Value  
(continued)

Ident	Object / Parameter name	Read/ Write	State Text	Default State	Description	Persistent Yes/No
MSV:9	Application mode	R/W	1: Analog control 2: Digital control 3: CO6 mode 4: Inverted CO6 mode 5: CO6 without alarms 6: Inverted CO6 without alarms	2: Digital control	Select the actuator application mode. <b>State 1:</b> Analog Control. Flow is controlled with an analog signal e.g. 0-10V. Design Flow Rate set via AV:30 Heating and/or AV:31 Cooling. Alternative AV:0 can be used. <b>State 2:</b> Digital Control. AV:1 is used to control the flow. Design Flow Rate set via AV:30 Heating and/or AV:31 Cooling. Alternative AV:0 can be used. <b>State 3:</b> CO6 mode. AV:1 is used to control the flow. Heating Design Flow Rate set via AV:30 and AV:31 for Cooling Design Flow Rate. Heating is connected to the CO6 valve to ports 5 & 6 and cooling to ports 1 & 4. <b>State 4:</b> Inverted CO6 mode. AV:1 is used to control the flow. Heating Design Flow Rate set via AV:30 and AV:31 for Cooling Design Flow Rate. Ports are inverted in relation to State 3. <b>State 5:</b> CO6 without alarms. AV:1 is used to control the flow. Heating Design Flow Rate set via AV:30 and AV:31 for Cooling Design Flow Rate. This state may be used if the Analog Input is required to be used other than CO6 feedback. Be aware that in this state the status for the CO6 valve is not shown. <b>State 6:</b> Inverted CO6 without alarms. AV:1 is used to control the flow. Heating Design Flow Rate set via AV:30 and AV:31 for Cooling Design Flow Rate. Ports are inverted in relation to State 3. This state may be used if the Analog Input is required to be used other than CO6 feedback. Be aware that in this state the status for the CO6 valve is not shown.	Yes
MSV:10	Application command & status	R/W (1-4) R (5-9)	1: Heating 2: Cooling 3: CO6 Shut Off 4: CO6 Start exercise 5: CO6 Moving towards Cooling 6: CO6 Moving towards Heating 7: CO6 Alarm 8: CO6 Exercising	1: Heating	States 1 to 4 are commands for the Actuator NovoCon® ChangeOver <sup>®</sup> and impact Energy Management Application MSV:13. States 5 to 8 are feedback from the Actuator NovoCon® ChangeOver <sup>®</sup> . <b>State 3, shut-off mode may only be used for maintenance and is only possible when the Flow Rate Setpoint is 0%.</b> In Central ChangeOver applications, state 1 and 2 are used to command heating or cooling.	Yes
MSV:11	CO6 auto exercise	R/W	1: ON 2: OFF	1: ON	ON: The ChangeOver <sup>®</sup> valve will be moved from current position to shut off and back again once per week to maintain free movement, if CO6 mode is selected. OFF: Exercising the valve should be handled by BMS.	Yes
MSV:12	Energy counter activation	R/W	1: Off 2: On	1: Off	Enable or disable energy counter	Yes
MSV:13	Energy management	R/W	1: Not active <b>Power Manager:</b> 2: Power limitation 3: Power control <b>Delta T Manager:</b> 4: Min. Delta T limitation 5: Set Delta T control 6: Min. Return T limitation 7: Max. Return T limitation 8: Set Return T control	1: Not used	Activate functions to optimize system performance. <b>State 1:</b> Not active <b>State 2:</b> If power is above the set value in AV:35/36, NovoCon will regulate to the specified limit AV:35 and/or AV:36. When this limitation is active, the warning BV:23 will be set to 'on'. <b>State 3:</b> The flowrate through the valve is controlled by AV:1 in kW or kBTU/h (selected in MSV:26) and is based on the flowrate and temperature inputs calculation. <b>State 4:</b> If delta T value in AV:37 and/or AV:38 is exceeded, NovoCon will begin to close the valve until the AV:37 and/or AV:38 values are reached. When this limitation is active, the warning BV:23 will be set to 'on'. <b>State 5:</b> The constant delta T is set in AV:37 and/or AV:38 and NovoCon will regulate within these limits. When this limitation is active, the warning BV:23 will be set to 'on'. <b>State 6:</b> NovoCon ensures the min. return temp. set in AV:39 & AV:40. Used mainly for cooling applications. When this limitation is active, the warning BV:23 will be set to 'on'. <b>State 7:</b> NovoCon ensures the max return temp. set in AV:39 & AV:40. Used mainly for heating applications. When this limitation is active, the warning BV:23 will be set to 'on'. <b>State 8:</b> A constant T2 value is set in AV:39 and/or AV:40. NovoCon will regulate to maintain these values constant.	Yes
MSV:20	Units used to set Design Flow Rate	R/W	1: L/h 2: % 3: GPM	1: L/h	Engineering Units used for the Design Flow AV:0, AV:30 and AV:31	Yes
MSV:21	Units used to set Flow Rate Setpoint	R/W	1: L/h 2: % 3: GPM 4: kW 5: kBTU/h	2: %	Engineering Units used for the desired Flow AV:1. NOTE: If kW or kBTU/h chosen then MSV:13 Power Controller (state:3) also becomes active	Yes
MSV:22	Units used to set Actual Flow feedback	R/W	1: L/h 2: % 3: GPM	1: L/h	Engineering Units used for AV:2	Yes
MSV:23	Units used to set Temperature	R/W	1: °C 2: °F	1: °C	Engineering Units used for AV:8, AV:37-40	Yes
MSV:24	Units used to set T1	R/W	1: °C 2: °F 3: Ohm	1: °C	Engineering Units used for Ai:1	Yes
MSV:25	Units used to set T2	R/W	1: °C 2: °F 3: Ohm	1: °C	Engineering Units used for Ai:2	Yes
MSV:26	Units used to set Power	R/W	1: kW 2: kBTU/h	1: kW	Engineering Units used for AV:32	Yes
MSV:27	Units used to set Energy counter	R/W	1: kWh 2: MJ 3: kBTU	1: kWh	Engineering Units used for AV:33 and AV:34	Yes

<sup>1)</sup> A zero Flow Rate Setpoint command (AV:1) closes the AB-QM, so that there is neither heating nor cooling. Do not use the CO6 maintenance shut-off function for this purpose.



The CO6 valve shut-off function should only be used for maintenance and only when the water temperature in terminal unit is equal to ambient temperature or the terminal unit is not mounted. A water temperature change inside of a closed coil could result in rising pressure and possible damage of to the terminal unit.



**BACnet Objects  
- Binary Value**

Ident	Object / Parameter name	Read/Write	Active Text (1)	Inactive Text (0)	Default	Description	Persistent Yes/No
BV:2	Direct or Inverse operation Mode	R/W	Inverse	Direct	Direct	Selection between Direct and Inverse operation mode. See Direct/Inverse diagram.	Yes
BV:3	Analog feedback signal	R/W	Active	Inactive	Inactive	By activating this feature, the analog output signal (AO:0) and the position of the valve opening become linked. The voltage output type and range is linked to the MSV:1 present value. This feature may be used for FCU fan control for example and is only made available when MSV:9 Application Mode are in State 1: Analog control or State 2: Digital control. If BV:3 is active and the analog output signal (AO:0) is written to manually it must be relinquished i.e. write "NULL" to return to the original setting of BV:3.	Yes
BV:10	Warning: Temperature of the actuator is out of recommended range	R	ON	OFF	na	The Temperature inside the Actuator is out of the recommended range.	No
BV:11	Alarm: No Control Signal	R	ON	OFF	na	The actuator has detected that it has no analog control signal.	No
BV:12	Alarm: Error during Closing	R	ON	OFF	na	Actuator can't completely close the AB-QM valve.	No
BV:13	Warning: Pre-set Conflict	R	ON	OFF	na	Conflict between the Mechanical AB-QM valve setting and the NovoCon® S. The mechanical valve setting must be 100% or above. The warning will also be activated if the Selected Valve Type has different stroke than the actually valve used. Validated during calibration.	No
BV:14	Warning: Voltage of power supply is too high	R	ON	OFF	na	Voltage of power supply is measured to be too high. When the measured voltage exceeds 43.4V the alarm will be turned ON for too high voltage. When the measured voltage is once more below 38.3V, the alarm will be turned OFF.	No
BV:15	Warning: Voltage of power supply is too low	R	ON	OFF	na	Voltage of power supply is measured to be too low. When the measured voltage level drops below 16.5V the alarm will be activated for too low voltage. When the measured voltage level drops below 16.1V the motor will also be turned off. When the measured voltage is once more above 17.5V, the motor will be activated again.	No
BV:16	Alarm: Error during Calibration	R	ON	OFF	na	There was an error during calibration of the actuator. E.g. the NovoCon® S actuator is not mounted on the valve or the valve is stuck.	No
BV:17	Warning: BACnet MAC-address Conflict was Detected	R	ON	OFF	na	Two or more devices on the same BACnet sub-network have the same MAC-address.	No
BV:18	Warning: Faults on the BACnet was detected	R	ON	OFF	na	Problems with communication on the network are detected.	No
BV:19	Alarm: An internal Error has been detected	R	ON	OFF	na	Re-calibrate or power cycle actuator to reset - actuator replacement may be necessary	No
BV:20	Alarm: CO6 in manual override or CO6 unable to move	R	ON	OFF	na	ChangeOver <sup>6</sup> actuator is in manual override or is unable to reach position.	No
BV:21	Alarm: CO6 actuator not connected or damaged	R	ON	OFF	na	The ChangeOver <sup>6</sup> actuator is not connected or is damaged.	No
BV:22	Warning: Temp. sensors are missing or misconnected	R	ON	OFF	na	Temp. sensors are missing or misconnected	No
BV:23	Warning: Energy limitation is active	R	ON	OFF	na	Limitation is active. E.g. Power limitation, min. delta T or min/max return T management limitation.	No
BV:24	Warning: Energy management controller out of range	R	ON	OFF	na	Power, delta T or return T setpoint out of range or the setpoint can't be achieved.	No

**BACnet Objects  
- Device Object**

List with some selected important Device Object properties.

Property	Value	Read / Write	Description	Persistent Yes/No
Object ID	Instance Range: 0 to 4194302	R/W	This property is normally called Device Instance number or Unique ID.	Yes
Object-Name	Combination of "NovoCon S" + Type and Object ID	R/W	Product name. Max. 25 characters.	Yes
Firmware revision	Current firmware version	R	BACnet software revision.	Yes
Application S/W version	Current Application SW version	R	Actuator Application Software version.	Yes
Location	This string is empty when actuator is new.	R/W	Free text can be used to describe location etc. Max. 50 characters.	Yes
Description	Danfoss NovoCon actuator with BACnet MS/TP	R/W	Product description. Max. 50 characters.	Yes
Segmentation-supported	NO SEGMENTATION	R	Actuator does not support segmentation.	Yes
Max-master	Default: 127 Range: 0-127	R/W	The MAX_master setting in NovoCon® S should be set to the number of devices (or the highest used MAC address) in the MS/TP sub network.	Yes

**BACnet Objects  
- Analog Input**

Ident	Object / Parameter name	Unit	Read / Write	Min	Max	Default units	Description	Persistent Yes/No
AI:0	Voltage or Current on analog input	5: Volts 2: mA	R	0	10V 20mA	Volts	Voltage(V) or Current(mA) level on the analog control input, measured by the actuator. Units comes from MSV:1 Analog Control signal type and range. This object is supported by COV. In CO6 and Inversed CO6 mode mA cannot be selected.	No
AI:1	T1 or resistance input	62: °C 64: °F, 4: Ohms	R	-10°C 10°F 900Ω	120°C 250°F 10kΩ	°C	Temperature/resistance measured from connected PT1000 sensors. For Power emission AV:32, AI:1 is temperature on the flow pipe and AI:2 is temperature on the return pipe. When used as potential free contacts: Closed circuit <900Ω, open circuit 100kΩ. Recommended max. cable length 2m. Units can be changed via the object's engineering units property. This object is supported by COV.	No
AI:2	T2 or resistance input							

**BACnet Objects  
- Analog Output**

Ident	Object / Parameter name	Unit	Read / Write	Min	Max	Default units	Description	Persistent Yes/No
AO:0	Voltage on analog output	Volts	R/W	0	10	Volt	Output Voltage value in Digital and Analog mode MSV:9. Note: In CO6 modes the present value is not writeable.	No

**BACnet Objects  
- Notification class**

Ident	Object / Parameter name	Description
NC:0	Alarm Notifier, Subscribe here for alarms	Subscribe devices for receiving alarms

NC:0 is an object where other BACnet devices can subscribe to be informed directly from this device if an alarm or warning is activated or cleared. A maximum of 4 devices can subscribe to this service. Subscribers of this object will be informed if any of the Warning or Alarms BV:10 to BV:24 is activated or cleared.

When the notification class NC:0 is going to be used to notify about changes with status of Warnings and Alarms (BV:10 – BV:24), it is necessary to subscribe for notifications for the entire day and week: From 00:00:00:00 to 23:59:59:99 and all 7 days of the week. This is because the actuator does not have a clock built in and will therefore not be able to handle notifications with respect to time.

**BACnet Objects  
- Averaging**

Ident	Object / Parameter name	Min. Value	Average value	Max. Value	Window Interval	Window Sample	Description	Persistent Yes/No
AVO:0	Average rectified voltage measured by the actuator		Updated according to actual measurements		1 Day	24	Average of the rectified voltage that powers the actuator.	No

**Valve Type Selection**



Values for flow are valid for water applications. For glycol mixtures, please use correction factor.

Index	Name	Nominal Flow	Units	Valve position for nominal flow [mm]	Setting Range Maximum [%]
1	AB-QM ISO DN 10LF	150	L/h	2.25	120
2	AB-QM ISO DN 10	275	L/h	2.25	120
3	AB-QM ISO DN 15LF	275	L/h	2.25	120
4 <sup>1)</sup>	AB-QM ISO DN 15	450	L/h	2.25	120
5	AB-QM ISO DN 20	900	L/h	2.25	120
6	AB-QM ISO DN 25	1700	L/h	4.5	110
7	AB-QM ISO DN 32	3200	L/h	4.5	110
8	AB-QM ISO DN 15HF	1135	L/h	4	110
9	AB-QM ISO DN 20HF	1700	L/h	4	110
10	AB-QM ISO DN 25HF	2700	L/h	4.5	110
11	AB-QM ISO DN 32HF	4000	L/h	4.5	110
12	AB-QM ANSI DN ½" LF	1.2	GPM	2.25	100
13	AB-QM ANSI DN ½"	2	GPM	2.25	100
14	AB-QM ANSI DN ½" HF	5	GPM	4	100
15	AB-QM ANSI DN ¾"	4	GPM	2.25	100
16	AB-QM ANSI DN ¾" HF	7.5	GPM	4	100
17	AB-QM ANSI DN 1"	7.5	GPM	4.5	100
18	AB-QM ANSI DN 1" HF	12	GPM	4.5	100
19	AB-QM ANSI DN 1¼"	14.1	GPM	4.5	100
20	AB-QM ANSI DN 1¼" HF	17.5	GPM	4.5	100
21 <sup>2)</sup>	User Defined Valve	NF	UF	VPNF	SRM

<sup>1)</sup> Default

<sup>2)</sup> The "User Defined Valve" is used only if NovoCon® S is not used with an AB-QM valve. Please contact your Danfoss representative to verify if the desired connection is possible.

When an ANSI valve is selected the units for flow and temperature are default changed from l/h to GPM and Celsius to Fahrenheit, and vice versa when an ISO valve is selected.

**BACnet BIBBs services**

Service	BIBBs	Init/Exe
ReadProperty	DS-RP-B	exe
WriteProperty	DS-WP-B	exe
Who-Is	DM-DDB-A	init
Who-Is	DM-DDB-B	exe
I-Am	DM-DDB-B	init
I-Am	DM-DDB-A	exe
Who-Has	DM-DOB-B	exe
I-Have	DM-DOB-B	init
DeviceCommunicationControl	DM-DCC-B	exe
ReinitializeDevice <sup>1)</sup>	DM-RD-B	exe
ConfirmedEventNotification	AE-N-I-B	init
UnconfirmedEventNotification	AE-N-I-B	init
AcknowledgeAlarm	AE-ACK-B	exe
GetEventInformation	AE-INFO-B	exe

Service	BIBBs	Init/Exe
GetAlarmSummary	AE-ASUM-B	exe
GetEnrollmentSummary	AE-ESUM-B	exe
AddListElement	DM-LM-B	exe
RemoveListElement	DM-LM-B	exe
ReadPropertyMultiple	DS-RPM-B	exe
WritePropertyMultiple	DS-WPM-B	exe
SubscribeCOV <sup>2)</sup>	DS-COV-B	exe
Restart	DM-R-B	exe
AtomicWriteFile	na	exe

<sup>1)</sup> NovoCon® S supports BACnet warm reset (power cycle) and Cold reset (factory reset). Note that after Cold/factory reset a calibration will be automatically performed and all settings will be reverted to factory settings.

<sup>2)</sup> COV is implemented for the following: Analog Inputs AI:0, AI:1 and AI:2, and for the following Analog Values AV:2 and AV:27.

**DIP Switch Settings**

BACnet: Auto MAC addressing is default. For manual MAC addressing using DIP Switches, MSV:5 must be set to: DIP Switch Settings.

Modbus: Manual MAC addressing is default. Automatic addressing is not available for Modbus. However, if an address has been assigned in BACnet before switching to Modbus, the address will also be used in Modbus if the DIP Switched are left in the default positions.

DIP Switch	Configuration name	OFF state (default)	ON state
1.	BACnet address / Modbus unit ID bit 0	Logic '0'	Logic '1'
2.	BACnet address / Modbus unit ID bit 1	Logic '0'	Logic '1'
3.	BACnet address / Modbus unit ID bit 2	Logic '0'	Logic '1'
4.	BACnet address / Modbus unit ID bit 3	Logic '0'	Logic '1'
5.	BACnet address / Modbus unit ID bit 4	Logic '0'	Logic '1'
6.	BACnet address / Modbus unit ID bit 5	Logic '0'	Logic '1'
7.	BACnet address / Modbus unit ID bit 6	Logic '0'	Logic '1'
8.	Termination resistor (120Ω)	No termination	Termination resistor enabled <sup>1)</sup>
9.	Not used		
10.	-	BACnet MS/TP <sup>2)</sup>	Modbus RTU <sup>2)</sup>

<sup>1)</sup> The actuator possesses a resistor, DIP Switch no. 8, that can be activated in the last actuator on the bus for correct termination of the bus.  
<sup>2)</sup> When the protocol is changed on DIP Switch no. 10, a power cycle is required to make the actuator adopt the newly selected protocol.

**DIP Switch Settings - Manual Addressing**

BACnet MAC address/Modbus Slave ID is set by DIP switch 1 to 7.  
 0 = OFF, 1 = ON

DIP switch 1, 2, 3, 4																DIP switch 5,6,7
0000	1000	0100	1100	0010	1010	0110	1110	0001	1001	0101	1101	0011	1011	0111	1111	
0*	1	2	3	4	5	6	7	8	9	10	11	12	13	14	15	000
16	17	18	19	20	21	22	23	24	25	26	27	28	29	30	31	100
32	33	34	35	36	37	38	39	40	41	42	43	44	45	46	47	010
48	49	50	51	52	53	54	55	56	57	58	59	60	61	62	63	110
64	65	66	67	68	69	70	71	72	73	74	75	76	77	78	79	001
80	81	82	83	84	85	86	87	88	89	90	91	92	93	94	95	101
96	97	98	99	100	101	102	103	104	105	106	107	108	109	110	111	011
112	113	114	115	116	117	118	119	120	121	122	123	124	125	126	127*	111

\* Addresses no. 0 and 127 must not be used.

**Example** Setting MAC address to 37:

DIP 1	DIP 2	DIP 3	DIP 4	DIP 5	DIP 6	DIP 7
ON	OFF	ON	OFF	OFF	ON	OFF

Modbus registers - Configuration

Modbus register	Read/Write	Modbus function	Modbus Data Type	Object / Parameter name	Description	Default	Unit	Description of usage	Persistent Yes/No
0x8000 32768	R/W	3,4 & 16	FLOAT	Design Flow Rate	Recommended to use 32796 for Heating and/or 32798 for cooling. Pre-set value for the Design Flow Rate when control signal is at 100%. Unit follows 32787	Nominal value from the Valve table in L/h	%, L/h, GPM	Design Flow Rate in Liters per hour i.e. 150 ..450 correspond to 150 ...450 L/h or in percent, i.e. 20 ... 100 correspond to 20 ... 100%. The maximum setting range is depending on the selected valve. See Valve Type Selection.	Yes
0x8002 32770	R/W	3,4 & 6	WORD	Control Fallback Time	Time before actuator reacts to a missing analog control signal	10	Minutes	Control Fallback Time in minutes, i.e.. 0 ... 60 correspond to 0 ... 60 minutes	Yes
0x8004 32772	R/W	3,4 & 16	FLOAT	Alpha Value	Value used for shaping the curve in Manual Defined Function (MDF) mode to fit the characteristics curve of a heat exchanger. If 33280 is in L/h in Digital mode, the alpha setting is ignored.	1.0	na	Alpha Value curve, i.e. 0.05 ... 1.00 correspond to 0.05 ... 1.00. Alpha = 1.00 is linear. Alpha = 0.2 is equal to the LOG function. See Alpha value diagram.	Yes
0x8006 32774	R/W	3,4 & 16	WORD	Valve closing or opening time	The time the actuator needs to move from 0% to 100% of Design Flow Rate. Use with 32803.	na	Seconds	Valve closing or opening time in seconds i.e.. 18 ... 700 correspond to 18 ... 700 seconds	Yes
0x8008 32776	R	3,4 & 6	FLOAT	Nominal Flow of the user defined valve	The Nominal flow of the user defined valve is shown here. This Object is used only if NovoCon® S is not used with an AB-QM valve. Please contact your Danfoss representative to verify if the desired connection is possible.	na	L/h or GPM, Unit type comes from Valve Table	Nominal flow e.g. in Liters per hour i.e. 0 ..450 correspond to 0 ...450 L/h	Yes
0x800A 32778	R	3 & 4	FLOAT	Valve position at nominal flow for User Defined Valve	Position in mm for nominal flow of the User Defined Valve. This Object is used only if NovoCon® S is not used with an AB-QM valve. Please contact your Danfoss representative to verify if the desired connection is possible.	2.25	Millimetre	Valve position for nominal flow in millimetre, i.e.. 0.5 ... 5.8 correspond to 0.5 ... 5.8 millimetre	Yes
0x800C 32780	R/W	3,4 & 6	FLOAT	Maximum value for the Design Flow in the User Defined Valve	Maximum level the Design Flow Rate can be increased to for the User Defined Valve. This Object is used only if NovoCon® S is not used with an AB-QM valve. Please contact your Danfoss representative to verify if the desired connection is possible.	120	Unit type follows 32787 selection: % or (L/h or GPM)	i.e. 0 ..150 correspond to 0 ...150 %	Yes
0x8012 32786	R/W	3,4 & 6	WORD	Direct or Inverse operation Mode	Selection between Direct and Inverse operation mode. See Direct/Inverse diagram.	0: Direct	0: Direct 1: Inverse	Selection between Direct and Inverse operation mode. See Direct/Inverse diagram.	Yes
0x8013 32787	R/W	3,4 & 6	WORD	Units used to set and display the Design Flow Rate	Units used to set and display the Design Flow Rate. Units for L/h & GPM comes from Selected Valve Type.	0: L/h	0: L/h 1: % 2: GPM	Engineering Units used for the Design Flow Rate.	Yes
0x8014 32788	R/W	3,4 & 6	WORD	Units used to set and display Flow Rate Setpoint	Units used to set and display Flow Rate Setpoint	1: %	0: L/h 1: % 2: GPM 3: kW 4: kBTU/h	Engineering Units used for the desired Flow 33280. Note: If kW or kBTU/h chosen then 32814 Power Controller (state 3) also becomes active.	Yes
0x8015 32789	R/W	3,4 & 6	WORD	Units used to set and display the Actual Flow Rate feedback	Units used to set and display the Actual Flow Rate feedback	0: L/h	0: L/h 1: % 2: GPM	Engineering Units used for 33282.	Yes
0x8016 32790	R/W	3,4 & 6	WORD	Units used to set temperature	Select between °C or °F to set and display temperature	0: °C	0: °C 1: °F	Engineering Units for 33796, 32836, 32838, 32840 & 32842.	Yes
0x8017 32791	R/W	3,4 & 6	WORD	Units used to set and display T1	Units used to read the temperature or resistance value.	0: °C	0: °C 1: °F 2: Ohms	Engineering Units used for 33218.	Yes
0x8018 32792	R/W	3,4 & 6	WORD	Units used to set and display T2				Engineering Units used for 33220.	
0x8019 32793	R/W	3,4 & 6	WORD	Units used to set Power	Units used to read the power usage.	0: kW	0: kW, 1: kBTU/h	Engineering Units for 33288.	Yes
0x801A 32794	R/W	3,4 & 6	WORD	Endian type	Byte ordering for LONG and FLOAT types	0: Big	0: Big 1: Little	Used endian type for float and long registers	Yes
0x801C 32796	R/W	3,4 & 16	FLOAT	Heating Design Flow Rate	Pre-set value for the Design Flow Rate when the control signal is at 100%. Unit follows 32787	Nominal value from the Valve table in L/h	%, L/h, GPM	Design Flow Rate in Liters per hour i.e. 150 ..450 correspond to 150 ...450 L/h or in percent, i.e. 20 ... 100 correspond to 20 ... 100%. The maximum setting range is depending on the selected valve. See Valve Type Selection.	Yes
0x801E 32798	R/W	3,4 & 16	FLOAT	Cooling Design Flow Rate					

Modbus registers - Configuration (continued)

Modbus register	Read/Write	Modbus function	Modbus Data Type	Object / Parameter name	Description	Default	Description of usage	Persistent Yes/No
0x802A 32810	R/W	3,4 & 6	WORD	Application mode	1: Analog control 2: Digital control 3: CO6 mode 4: Inverted CO6 mode 5: CO6 without alarms 6: Inverted CO6 without alarms	2: Digital	Select the actuator application mode. <b>State 1:</b> Analog Control. Flow is controlled with an analog signal e.g. 0-10V. Design Flow Rate set via register 32796 Heating and/or 32798 Cooling. Alternative 32738 can be used. <b>State 2:</b> Digital Control. Register 33280 is used to control the flow. Design Flow Rate set via register 32796 Heating and/or 32798 Cooling. Alternative 32738 can be used. <b>State 3:</b> CO6 mode. Register 33280 is used to control the flow. Heating Design Flow Rate set via register 32796 and register 32798 for Cooling Design Flow Rate. Heating is connected to the CO6 valve to ports 5 & 6 and cooling to ports 1 & 4. <b>State 4:</b> Inverted CO6 mode. Register 33280 is used to control the flow. Heating Design Flow Rate set via register 32796 and 32798 for Cooling Design Flow Rate. Ports are inverted in relation to State 3. <b>State 5:</b> CO6 without alarms. Register 33280 is used to control the flow. Heating Design Flow Rate set via register 32796 and 32798 for Cooling Design Flow Rate. This state may be used if the Analog Input is required to be used other than CO6 feedback. Be aware that in this state the status for the CO6 valve is not shown. <b>State 6:</b> Inverted CO6 without alarms. register 33280 is used to control the flow. Heating Design Flow Rate set via register 32796 and 32798 for Cooling Design Flow Rate. Ports are inverted in relation to State 3. This state may be used if the Analog Input is required to be used other than CO6 feedback. Be aware that in this state the status for the CO6 valve is not shown.	Yes
0x802B 32811	R/W	3,4 & 6	WORD	Application command & status	1: Heating 2: Cooling 3: CO6 Shut Off 4: CO6 Start exercise 5: CO6 Moving towards Cooling 6: CO6 Moving towards Heating 7: CO6 Alarm 8: CO6 Exercising	1: Heating	States 1 to 4 are commands for the Actuator NovoCon® ChangeOver6 and impact Energy Management Application register 32814. States 5 to 8 are feedback from the Actuator NovoCon® ChangeOver6. <b>State 3, shut-off mode may only be used for maintenance and is only possible when the Flow Rate Setpoint is 0%.</b> In Central ChangeOver applications, state 1 and 2 are used to command heating or cooling.	Yes
0x802C 32812	R/W	3,4 & 6	WORD	CO6 auto exercise	1: ON 2: OFF	1: ON	1: ON: The ChangeOver6 valve will be moved from current position to shut off and back again once per week to maintain free movement, if CO6 mode is selected. 2: OFF: Exercising the valve should be handled by BMS.	Yes
0x802D 32813	R/W	3,4 & 6	WORD	Energy counter activation	1: Off 2: On	1: Off	Enable or disable energy counter	Y
0x802E 32814	R/W	3,4 & 6	WORD	Energy management	1: Not active <b>Power Manager:</b> 2: Power limitation 3: Power control <b>Delta T Manager:</b> 4: Min. Delta T limitation 5: Set Delta T control 6: Min. Return T limitation 7: Max. Return T limitation 8: Set Return T control	1: Not used	Activate functions to optimize system performance. <b>State 1:</b> Not active. <b>State 2:</b> If power is above the set value in register 32832 or register 32834, NovoCon will regulate to the specified limit register 32832 and/or 32834. When this limitation is active, the warning bit 23 in register 33536 will be set to 'on'. <b>State 3:</b> The flowrate through the valve is controlled by register 33280 in kW or kBTU/h (selected in 32793) and is based on the flowrate and temperature inputs. <b>State 4:</b> If delta T value in register 32836 and/or 32838 is exceeded, NovoCon will begin to close the valve until the register 32836 and/or 32838 values are reached. When this limitation is active, the warning bit 23 in register 33536 will be set to 'on'. <b>State 5:</b> The constant delta T is set in register 32836 and/or 32838 and NovoCon will regulate within these limits. When this limitation is active, the warning bit 23 in register 33536 will be set to 'on'. <b>State 6:</b> NovoCon ensures the min. return temp. set in register 32840 & 32842. Used mainly for cooling applications. When this limitation is active, the warning bit 23 in register 33536 will be set to 'on'. <b>State 7:</b> NovoCon ensures the max return temp. set in register 32840 & 32842. Used mainly for heating applications. When this limitation is active, the warning bit 23 in register 33536 will be set to 'on'. <b>State 8:</b> A constant T2 value is set in register 32840 and/or 32842. NovoCon will regulate to maintain these values constant.	Y
0x8020 32800	R/W	3,4 & 6	WORD	Analog Control signal type and range	Used to select the analog control signal input type and range	2: 0-10 VDC	Select 1, 2 or... based on the table below: 1: 0-5 VDC 2: 0-10 VDC 3: 2-10 VDC 4: 5-10 VDC 5: 2-6 VDC 6: 6-10 VDC 7: 0-20 mA 8: 4-20 mA	Yes
0x8021 32801	R/W	3,4 & 6	WORD	Missing Control Signal Fallback Action	The action that the actuator will commence upon a missing analog control signal.	1: No action	Select 1, 2 or... based on the table below: 1: No action 2: CLOSE 3: OPEN 4: Go to 50% of Design Flow Rate	Yes

<sup>1)</sup> A zero Flow Rate Setpoint command (33280) closes the AB-QM, so that there is neither heating nor cooling, do not use the CO6 maintenance shut-off function for this purpose.



The CO6 valve shut-off function should only be used for maintenance and only when the water temperature in terminal unit is equal to ambient temperature or the terminal unit is not mounted. A water temperature change inside of a closed coil could result in rising pressure and possible damage of to the terminal unit.

Modbus registers - Configuration (continued)

Modbus register	Read/Write	Modbus function	Modbus Data Type	Object / Parameter name	Description	Default	Unitw	Description of usage	Persistent Yes/No
0x8022 32802	R/W	3,4 & 6	WORD	Selected Valve Type	This is the AB-QM valve type that the actuator is set-up to control	4: AB-QM DN 15	na	See table "Valve Type Selection 1-17"	Yes
0x8023 32803	R/W	3,4 & 6	WORD	Actuator Speed	The amount of time the actuator takes to move 1mm or alternatively, a specified constant time function (see 32774). The Constant Time value range is 18-700 seconds.	4: 24 sec/mm	na	Select 1, 2 or... based on the table below: 1: 3 sec/mm 2: 6 sec/mm 3: 12 sec/mm 4: 24 sec/mm 5: Constant Time (set by register 0x8006)	Yes
0x8024 32804	R/W	3,4 & 6	WORD	Baud Rate	Baud Rate used for bus communication	1: Auto Baud Rate Detection	na	Select 1, 2 or... based on the table below: 1: Auto Baud Rate Detection 2: 9600 bps 3: 19200 bps 4: 38400 bps 5: 57600 bps 6: 76800 bps 7: 115200 bps	Yes
0x8025 32805	R/W	3,4 & 6	WORD	Select UART mode	Supported transmission modes	5: Auto parity	na	Select 1, 2, 3 or 4 based on the table below: 1: 1-8-N-2 2: 1-8-O-1 3: 1-8-E-1 4: 1-8-N-1 5: Auto parity Data format: (Start bit-Data bits-Parity-Stop bits)	Yes
0x8026 32806	R/W	3,4 & 6	WORD	Slave ID	Slave ID used for communication.	na	na	Slave ID used for communication	Yes
0x8027 32807	R/W	3,4 & 6	WORD	Slave ID assignment method	The Slave ID address selection method.	1: DIP Switch Settings	na	1: DIP Switch Settings 2: User configuration over Modbus If DIP Switches are in an invalid position the actuator will automatically check if a Slave ID is present in the User Configuration.	Yes
0x8028 32808	R/W	3,4 & 6	WORD	BUS protocol	Select field bus protocol to be used. See also the DIP Switch Settings section of the data sheet. When the protocol is changed, a power cycle is required to make the actuator adopt the newly selected protocol.	1: DIP switch	na	Select 1, 2 or 3 based on the table below: 1: DIP switch 2: BACnet 3: Modbus	Yes
0x8029 32809	R/W	3,4 & 6	WORD	LED Control	The LED display options.	1: Normal LED mode	na	Select 1, 2 or... based on the table below: 1: Normal LED mode 2: Show alarms only 3: All LED's OFF 4: Blink (can be used to locate the actuator)	Yes
0x8030 32816	R/W	3,4 & 6	WORD	Units used to set Energy counter	Units used to set energy counter	0: kWh	0: kWh 1: MJ 2: kBTU	Engineering Units used for 33290 & 33292.	Yes
0x8031 32817	R/W	3,4 & 6	WORD	Analog feedback signal	Set analog output according to valve position	0: Inactive	na	0: Inactive 1: Active By activating this feature, the analog output signal (33286) and the position of the valve opening become linked. The voltage output type and range is linked to the 32800 present value. This feature may be used for FCU fan control for example and is only made available when 32810 Application Mode are in State 1: Analog control or State 2: Digital control. If 32817 is active and the analog output signal (33286) must be written to manually, it is necessary to change the setting of 32817 to inactive.	Yes
0x8500 34048	W	6	WORD	Reset	Warm reset = Power cycle. Cold reset = Factory reset. Note that after factory reset a calibration will be automatically be performed and all settings will be reverted to factory settings.	na	na	0x5741 / 22337: Warm reset 0x434F / 17231: Cold reset.	na

Modbus registers - Operating

Modbus register	Read/Write	Modbus function	Modbus Data Type	Object / Parameter name	Description	Default	Unit	Description of usage	Persistent Yes/No
0x8200 33280	R/W	3,4 & 16	FLOAT	Flow Rate Setpoint	The Flow Rate Setpoint through the AB-QM valve. Unit follows 32788	100%	%, L/h, GPM, kW, kBTU/h	Flow Rate Setpoint in percent, i.e.0 ... 100 correspond to 0 ... 100%	No
0x8202 33282	R	3 & 4	FLOAT	Actual Flow Rate feedback	Flow Rate Indication based on the position of the Actuator stem. Unit follows 32788	na	%, L/h, GPM	Design Flow Rate feedback in percent, i.e. 0 ... 100 correspond to 0 ... 100%. If L/h (GPM) is selected in 32787 then the valve flow rate is set to the selected valve's 32776 maximum value. Otherwise 100%	No
0x8204 33284	R/W	3,4 & 6	WORD	Actuator Mode and special features	Shows present mode of actuator. Calibration, Flush and de-air may be started from here	1: Normal	na	Select 1, 2 or... based on the table below: 1: Normal 2: Calibration 3: Flush 4: De-Air 5: Alarm	Yes, except state 3,4 & 5
0x8206 33286	R/W	3,4 & 16	FLOAT	Voltage on analog output	Output Voltage value in Digital and Analog mode 32810. Note: In CO6 and Inversed CO6 mode the present value is not writeable	V	Volts	Voltage level i.e. 0.00 ... 10.00 correspond to 0.00 ... 10.00 V	No
0x8208 33288	R/W	3,4 & 16	FLOAT	Power emission	The hydronic power emission of the terminal unit, based on calculations from water flow rate and the temperature difference between supply (33218) and return (33220) pipes. Positive values reflect heating power emission. Negative values reflect cooling power emission. Units can be changed via the object's engineering units property.	kW	kW, kBTU/h	Power in kW or kBTU/h i.e. -1000.00 ... 1000.00 correspond to -1000.00 ... 1000.00 kW or in kBTU/h, i.e. -1000.00 ... 1000.00 correspond to -1000.00 ... 1000.00 kBTU/h	No

Modbus registers - Operating (continued)

Modbus register	Read/Write	Modbus function	Modbus Data Type	Object / Parameter name	Description	Default	Unit	Description of usage	Persistent Yes/No
0x820A 33290	R/W	3,4 & 16	FLOAT	Heating Energy counter	Energy counter for heating	kWh	kWh, MJ, kBTU	Accumulative Energy counter for heating. i.e. 0.00 ... 1000.00 correspond to 0.00 ... 1000.00 kWh	Yes
0x820C 33292	R/W	3,4 & 16	FLOAT	Cooling Energy counter	Energy counter for cooling	kWh	kWh, MJ, kBTU	Accumulative Energy counter for cooling. i.e. 0.00 ... 1000.00 correspond to 0.00 ... 1000.00 kWh	Yes
0x8040 32832	R/W	3,4 & 16	FLOAT	Heating max. Power	Pre-set value for the design power, in heating mode, when control signal is at 100%	kW	kW, kBTU/h	When using register 32814 state Power limiter this is the maximum allowed hydronic energy output. This value is intended to limit the heating power through the terminal unit. i.e. 0.00 ... 10.00 correspond to 0.00 ... 10.00 kW	Yes
0x8042 32834	R/W	3,4 & 16	FLOAT	Cooling max. power	Pre-set value for the design power, in cooling mode, when control signal is at 100%	kW	kW, kBTU/h	When using register 32814 state Power limiter this is the maximum allowed hydronic energy output. This value is intended to limit the cooling power through the terminal unit. i.e. 0.00 ... 10.00 correspond to 0.00 ... 10.00 kW	Yes
0x8044 32836	R/W	3,4 & 16	FLOAT	Heating Delta T	Set value for delta T	°C	°C or °F	For register 32814 state Minimum Delta T management and Set Delta T control, this is the value the control is based on for heating. i.e. 5 ... 50 correspond to 5°C ... 50°C	Yes
0x8046 32838	R/W	3,4 & 16	FLOAT	Cooling Delta T	Set value for delta T	°C	°C or °F	For register 32814 state Minimum Delta T management and Set Delta T control, this is the value the control is based on for cooling. i.e. 5 ... 50 correspond to 5°C ... 50°C	Yes
0x8048 32840	R/W	3,4 & 16	FLOAT	Heating T2	Set value for T2 (return)	°C	°C or °F	For register 32814 state Max. Return T management and Set return T control, this is the value the control is based on for heating. i.e. 5 ... 50 correspond to 5°C ... 50°C	Yes
0x804A 32842	R/W	3,4 & 16	FLOAT	Cooling T2	Set value for T2 (return)	°C	°C or °F	For register 32814 state Min. Return T management and Set return T control, this is the value the control is based on for cooling. i.e. 5 ... 50 correspond to 5°C ... 50°C	Yes

Modbus registers - Information

Modbus register	Read/Write	Modbus function	Modbus Data Type	Object / Parameter name	Description	Default	Unit	Description of usage	Persistent Yes/No
0x8100 33024	R	3 & 4	FLOAT	Nominal flow of the selected valve type	Nominal flow of the selected valve type	450	L/h or GPM, Unit type comes from Valve Table	Nominal flow e.g. in Litres per hour i.e. 0..450 correspond to 0 ... 450 L/h.	na
0x8102 33026	R	3 & 4	FLOAT	Valve position at nominal flow	Position in mm for nominal flow of the selected valve	na	Millimetre	Valve position for nominal flow in millimetre, i.e.. 0.5 ... 5.8 correspond to 0.5 ... 5.8 millimetre.	na
0x8104 33028	R	3 & 4	FLOAT	Maximum value of the Design Flow Rate	Maximum level the Design Flow Rate can be increased to for the selected valve	Setting Range Maximum from Valve table	%	Maximum level of the Design Flow Rate in percent, i.e. 20 ... 100 correspond to 20 ... 100%.	na
0x8120 33056	R/W	3 & 4	STRING	Device name	Product name	NovoCon S	na	Ascii coded STRING	Yes
0x8140 33088	R	3 & 4	STRING	Model name	Type of the actuator	CO6	na	Ascii coded STRING	Yes
0x8160 33120	R	3 & 4	STRING	Vendor name	Name of the Manufacture	Danfoss A/S	na	Ascii coded STRING	Yes
0x8180 33152	R/W	3,4 & 16	STRING	Location description	Free text can be used to describe location etc. E.g. Room 1	na	na	Ascii coded STRING. Max. 50 characters.	Yes
0x81A0 33184	R	3,4	String	Serial number	Serial number of the actuator	na	1	Description of this object holds the serial number of the actuator, programmed at the production time.	Yes
0x8108 33032	R	3,4	LONG	Product ID	Serial number of the actuator	na	1	Unique Product id. The last part of the serial number.	Yes
0x810A 33034	R	3 & 4	WORD	SW version	Software version of the actuator	na	na	Ascii coded WORD	Yes
0x810B 33035	R	3 & 4	WORD	HW version	Hardware version of the actuator	na	na	Ascii coded WORD	Yes
0x81C0 33216	R	3 & 4	FLOAT	Voltage or Current on analog input	Voltage(V) or Current(mA) level on the analog control input, measured by the actuator. In CO6 modes mA cannot be selected.	na	Volts / mA	Voltage level measured i.e. 0.00 ... 10.00 correspond to 1.00 ... 10.00 V or in mA, i.e. 0.00 ... 20.00 correspond to 0.00 ... 20.00 mA	No
0x81C2 33218	R	3 & 4	FLOAT	T1 or resistance input	Temperature/resistance measured from connected PT1000 sensors. For Power emission 33288, register 33218 is temperature on the flow pipe and 33220 is temperature on the return pipe.	°C	°C, °F, Ohms	Temperature measured in °C i.e. -10°C ... 120°C or resistance measured i.e. 900Ω ... 10kΩ. When used as potential free contacts: Closed circuit <900Ω, open circuit 100kΩ. Recommended max. cable length 2m.	No
0x81C4 33220	R	3 & 4	FLOAT	T2 or resistance input	Temperature/resistance measured from connected PT1000 sensors. For Power emission 33288, register 33218 is temperature on the flow pipe and 33220 is temperature on the return pipe.	°C	°C, °F, Ohms	Temperature measured in °C i.e. -10°C ... 120°C or resistance measured i.e. 900Ω ... 10kΩ. When used as potential free contacts: Closed circuit <900Ω, open circuit 100kΩ. Recommended max. cable length 2m.	No
0x8402 33794	R	3 & 4	FLOAT	Rectified voltage measured by the actuator	Measured rectified voltage which powers the actuator	na	Volts	Rectified voltage which powers the actuator. Too low voltage: 16.1-17.5V Too high voltage: 38.3-43.4V	No
0x8404 33796	R	3 & 4	FLOAT	Temperature in the actuator	Temperature measured inside the Actuator	na	na	Temperature measured inside the actuator. Unit is decided by 32790.	No
0x8406 33798	R	3 & 4	LONG	Total Operating Hours	Total Operating Hours of the actuator	Hours	Hours	Total Operating Hours of the actuator	Yes
0x8408 33800	R	3 & 4	LONG	Lifetime estimate	Calculated percentage of expended lifetime	%	na	At 100% the valve and actuator have reached the estimated minimum lifetime. Replacement of valve and actuator is recommended.	Yes
0x8410 33808	R	3 & 4	LONG	Minutes since last power-up	Minutes since the last power-up of the actuator	Minutes	Minutes	Minutes since the last power-up of the actuator	No
0x8412 33810	R	3 & 4	LONG	Minutes since last calibration	Minutes since the last time the actuator was calibrated to an AB-QM valve	Minutes	Minutes	Minutes since the last time the actuator was calibrated to a valve	Yes
0x8414 33812	R	3 & 4	LONG	Minutes since fully closed	Minutes since the last time the AB-QM valve was fully closed	Minutes	Minutes	Minutes since the last time the valve was fully closed	Yes
0x8416 33814	R	3 & 4	LONG	Minutes Since Fully Opened	Minutes since the last time the AB-QM valve was fully opened	Minutes	Minutes	Minutes since the last time the valve was fully opened	Yes

Alarms & warning

Modbus register	Read/Write	Modbus function	Modbus Data Type	Object / Parameter name	Description	Default	Description of usage	Persistent Yes/No
0x8300 33536	R	3&4	LONG	Alarm: No Control Signal	The actuator has detected that it has no analog control signal	0: OFF	Bit 0: 0:OFF; 1:ON	No
				Alarm: Error during Closing	Actuator can't completely close the AB-QM valve	0: OFF	Bit 1: 0:OFF; 1:ON	No
				Alarm: Error during Calibration	There was an error during calibration of the actuator. E.g. the NovoCon® S actuator is not mounted on the valve or the valve is stuck	0: OFF	Bit 2: 0:OFF; 1:ON	No
				Alarm: An internal Error has been detected	Re-calibrate or power cycle actuator to reset - actuator replacement may be necessary	0: OFF	Bit 3: 0:OFF; 1:ON	No
				Alarm: CO6 in manual override or CO6 unable to move	ChangeOver <sup>®</sup> actuator is in manual override or is unable to reach position.	0: OFF	Bit 4: 0:OFF; 1:ON	No
				Alarm: CO6 actuator not connected or damaged	The ChangeOver <sup>®</sup> actuator is not connected or is damaged.	0: OFF	Bit 5: 0:OFF; 1:ON	No
				Alarm: Temp. sensors are missing or misconnected	Temp. sensors are missing or misconnected	0: OFF	Bit 6: 0:OFF; 1:ON	No
				Warning: Temperature of the actuator is out of recommended range	The Temperature inside the Actuator is out of the recommended range	0: OFF	Bit 16: 0:OFF; 1:ON	No
				Warning: Pre-set Conflict	Warning: Conflict between the Mechanical AB-QM valve setting and the NovoCon® S. The mechanical valve setting must be 100% or above. The warning will also be activated if the Selected Valve Type has different stroke than the actually valve used. Validated during calibration.	0: OFF	Bit 17: 0:OFF; 1:ON	No
				Warning: Voltage of power supply is too high	Voltage of power supply is measured to be too high. When the measured voltage exceeds 43.4V the alarm will be turned ON for too high voltage. When the measured voltage is below 38.3V the alarm will be turned OFF	0: OFF	Bit 18: 0:OFF; 1:ON	No
				Warning: Voltage of power supply is too low	Voltage of power supply is measured to be too low. When the measured voltage level drops below 16.5V the alarm will be activated for too low voltage. When the measured voltage level drops below 16.1V the motor will also be turned off. When the measured voltage is once more above 17.5V the motor will be activated	0: OFF	Bit 19: 0:OFF; 1:ON	No
				Warning: Faults on communication was detected	Problems with Communication on the network are detected	0: OFF	Bit 21: 0:OFF; 1:ON	No
				Warning: Invalid Slave ID setting	Slave ID assignment was done incorrectly to either 0 or 127	0: OFF	Bit 22: 0:OFF; 1:ON	No
Warning: Energy limitation is active	Limitation is active. E.g. Power limitation, min. delta T or min/max return T management limitation.	0: OFF	Bit 23: 0:OFF; 1:ON	No				
Warning: Energy management controller out of range	Power, delta T or return T setpoint out of range or the setpoint can't be achieved.	0: OFF	Bit 24: 0:OFF; 1:ON	No				

Firmware update

Manual update

Using BACnet MS/TP

Ident	Object / Parameter name	Read/Write	State Text	Default State	Description
MSV:19	Firmware update	R/W	1: Normal 2: Prepare 3: Ready 4: Error 5: Received 6: Update	1: Normal	Commands & status for firmware update. Method used to update the firmware: • Send 'Prepare' command to MSV:19. NovoCon® S will prepare for the firmware update and change status to 'Ready'. • Send file to FIL:0. If successful, status should be 'Received'. • Send 'Update' command. NovoCon® S will reboot and update the firmware. The status should be 'Normal' after a successful firmware update.

Ident	Object / Parameter name	Read/Write	State Text	Default State	Description
FIL:0	File	W	File used to update the firmware	na	Used to transfer the new firmware to NovoCon® S.

Using Modbus RTU

Modbus register	Read/Write	Modbus function	Modbus Data Type	Object / Parameter name	Description	Default	Description of usage
0x8501 34049	R/W	3, 4 & 6	WORD	Firmware update	1: Normal 2: Prepare 3: Ready 4: Error 5: Received 6: Update	1: Normal	Commands & status for Firmware update. Method used to update the Firmware: • Send 'Prepare' command to 34049. NovoCon® S will prepare for the firmware update and change status to 'Ready'. • Send file using Modbus function 21. If successful, status should be 'Received'. • Send 'Update' command. NovoCon® S will reboot and update the software. The status should be 'Normal' after a successful software update



When using modbus function 21 (0x15) to update the firmware in NovoCon® S it is necessary to perform the upload in smaller sections due to modbus limitations in file size, please see the modbus standard for more details.

Broadcast, update multiple NovoCon® S by sending the firmware to Slave Id 0, is supported in modbus. However each NovoCon® S must be Prepared before the firmware upload is performed.

**Danfoss NovoCon® Configuration tool**

Easy configuration, commissioning and firmware updates can be performed with the Danfoss configuration tool. Please see separate operating manual.



Temperature sensors

Functional description

The sensor unit consists of a platinum element, the resistance value of which, changes proportionally with the temperature.

Pt 1000 ohm sensor (1000 ohm at 0°C).

The sensor is adjusted and meets the tolerance requirements of EN 60751 Class B.

The accuracy of temperature measurement is approximately 0.5° in typical operating range. It is unlikely, that during calculation of ΔT, deviation of both sensors would be summed up. Therefore, it is estimated that ΔT measurement accuracy is 0.5° when the sensors are mounted correctly.

It is not recommended to use longer wires on temperature sensors than 2m due to risk of electromagnetic interference. If long or thin wires are used it may be necessary to make an offset of the temperature reading in the BMS system.

R (Typ.) Ohm	Temp. °C	Temp. °F	Tolerance. °C
1117	30	86	0.45
1078	20	68	0.40
1039	10	50	0.35
1000	0	32	0.30
961	-10	14	0.35
922	-20	-4	0.40
882	-30	-22	0.45

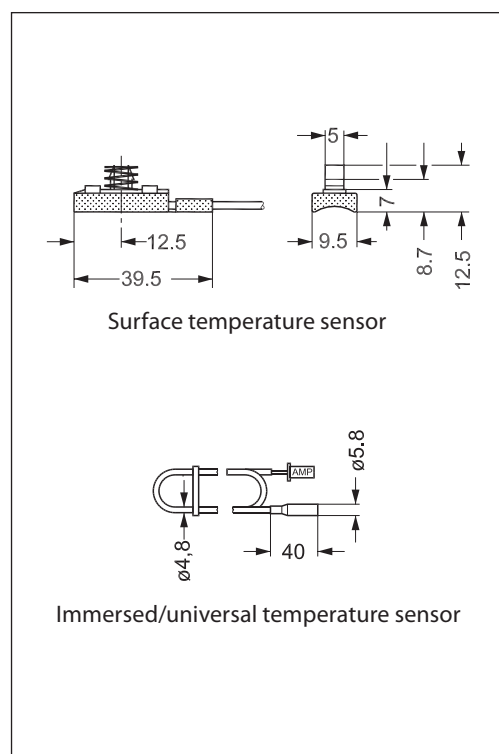

Tender text

NovoCon® S actuator

Modulating geared actuator with field bus (BACnet MS/TP and Modbus RTU) connectivity used to control pressure independent balancing and control valves DN10-32.

Control signal: BACnet MS/TP, Modbus RTU, 0-10V/2-10V, 0-20/4-20mA

Direct connection to 6-port ball valve actuator with position feedback signal <sup>1)</sup>

Direct connection to 2x PT1000 surface/immersed sensors and emission power indication

Direct connection I/O: 2x resistance, AO and AI <sup>3)</sup>

Actuator functionality is remotely accessible via the field bus:

- Design flow pre-setting
- Flushing the valve and terminal unit
- Error during closing intrinsic alarm reporting
- Alarm if CO6 6-port ball valve actuator is blocked, in manual override or disconnected <sup>1)</sup>
- Supply and return temperature readings, emission power indication <sup>2)</sup>
- Energy counter (kWh, MJ, kBtu) <sup>2)</sup>
- Alarm high/low deltaT and temperature sensors disconnected <sup>2)</sup>
- Alpha characteristics setting
- Speed selection 3/6/12/24 s/mm
- Opening/closing time selection from 18s to 700s
- Auto MAC addressing (BACnet only)
- Auto Baud rate detection
- Flow indication based on measured stroke in l/h

Eu.bac interchangeability approved in combination with PIBCV valve

Supply Voltage: 24V DC/AC 50/60Hz

Spindle position accuracy: ±0.05mm

Cables: Halogen free plug-in available in 1.5m, 5m and 10m length

Temperature sensors: plug-in 2x PT1000 surface or immersed 1.5m length

64 actuators can be connected to the same network

IP Class: 54

Stroke: 7mm

BACnet Testing Laboratories (BTL) listed BACnet MS/TP fieldbus device <sup>4)</sup>

Manual override function

Configuration tool available easy configuration, commissioning and firmware updates

Commissioning tool available for addressing, parametrization and hydronic continuous commission

<sup>1)</sup> CO6 application

<sup>2)</sup> Energy application

<sup>3)</sup> Remote I/O application

<sup>4)</sup> Certification in progress

**Trouble shooting**

**BACnet Fieldbus check:**

It is possible to check the fieldbus state by examining error messaging related to the actuator in order to verify communication and detect early potential fieldbus related problems. This is done by the object values AV:15 to AV:19.

**Quality of the BACnet network:**

An important thing for good operation of the actuator is a well functioning network. Some values that tell you about the quality of the network can be found in the objects AV:15 to AV:19. The most important values are AV:17 Server Error Count and AV:19 Server Timeout Error. These two values should be much lower than AV:15, AV:16 and AV:18. As a general rule, it is important that AV:17 and AV:19 are not constantly increasing their count.

**Quality of power supply:**

The object / register AV:6 / 33794 may be used to check if the power supply and cabling, used to supply the actuator with power, is according to specification requirements. The present value of AV:6 / 33794 represents the current voltage measured inside the actuator. This is the voltage that the actuator monitors at all times and subsequently reacts on if outside the recommended range. See in the table below how the actuator reacts at different voltage levels.

Voltage (Present value of AV:6 / 33794)	Reaction
Voltage below 16.5V	Start alarm indication with LED. Initiate and alarm BV: 15 / 33536 Bit 19 and that the supply voltage is too low.
Voltage below 16.1V	Motor is stopped. The LEDs indicating alarm and actuator still initiating alarm BV:15 / 33535 Bit 19 if the voltage hasn't dropped too low.
When voltage rises above 17.5V again	Motor can run again. LED alarm indication stops and returns to normal operation. Alarm BV:15 / 33536 Bit 19 returns to normal operation.
When voltage rises above 43.4V	Start alarm indication with LED. Initiate an alarm BV:14 / 33536 Bit 18.
When voltage drops below 38.3V again	LED alarm indication stops and returns to normal operation. Alarm BV:14 / 33536 Bit 18 returns to normal operation.

**NB:** the voltage level will be constantly changing depending on the operational activity of the entire group of actuators and other devices connected. The supply voltage will go up and down in value if:

- Power supply is not strong and stable
- If long cables are used in a daisy chain setup

A higher number of actuators running at the same time will reduce the supply voltage (for the last devices on a daisy chain cable, in particular).

The actuator's voltages are considered to be OK when all values of AV:6 / 33794 are above 18V, when all actuators are moving the motor/running. To ensure voltage in each device is OK under worst case operational conditions, the following is recommended:

- Run all the actuators on the daisy chain cable at the same time. While all are running, check each value of AV:6 / 32794. These values should still be above 18V and no previously mentioned voltage level alarms should be initiated or indicated. If LEDs indicate an alarm state or a BACnet/Modbus alarm is initiated, or a value less than 18V is observed, then cabling should be reviewed.
- Check the values of AVO:0. This BACnet object holds 3 values: Average measured voltage, Maximum measured voltage and Minimum measured voltage. The most important value here is the Minimum measured voltage. It can tell you the lowest voltage that has been measured during operation of the actuator.





**Danfoss A/S**

Heating Segment • [heating.danfoss.com](http://heating.danfoss.com) • +45 7488 2222 • E-Mail: [heating@danfoss.com](mailto:heating@danfoss.com)

Danfoss can accept no responsibility for possible errors in catalogues, brochures and other printed material. Danfoss reserves the right to alter its products without notice. This also applies to products already on order provided that such alterations can be made without subsequential changes being necessary in specifications already agreed. All trademarks in this material are property of the respective companies. Danfoss and all Danfoss logotypes are trademarks of Danfoss A/S. All rights reserved.