

Managed Ethernet switch 500NMD02

EDS500 series - Ethernet & DSL switches

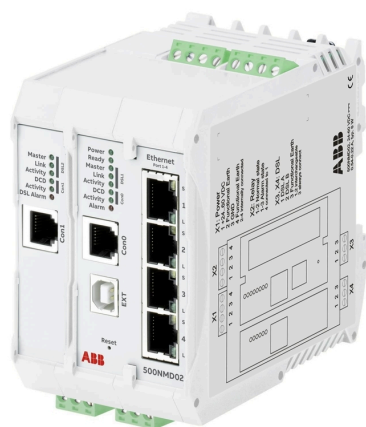

- Integrated managed layer-2-switch
- 24... 60 V DC supply voltage
- 4x 10/100 BaseT (RJ45, auto-negotiating)
- 2x SHDSL-ports for copper wire
- Provides redundant topologies by the Spanning Tree Protocol (STP/ RSTP/ MSTP)
- 1x RS-232/ RS-485 and 1x RS-232 interface suitable for tunneling of serial protocols

Application

The DIN rail mountable 500NMD02 is a managed plug and play layer-2-switch, providing:

- 4 fast Ethernet auto-negotiating RJ45 ports with auto MDI/X (Automatic Crossover Detection and Correction)
- two 2-wire SHDSL-ports for use with private copper cables
- 1x RS-232/ RS-485 and 1x RS-232 interface suitable for tunneling of serial protocols

The switch is able to provide redundant topologies by the Spanning Tree Protocol (STP/ RSTP/ MSTP). It supports VLAN frames and tunneling of serial data. Ethernet may be distributed within a station through the 4 RJ45 ports of the switch.

The SHDSL port can be used for interconnecting stations with a maximum distance of 25 km (copper cable with diameter of 0.8 mm). The SHDSL interface can be connected to any EDS500 SHDSL compatible device including 560NMS24 and 560NMS34 and any EFM based SHDSL device.

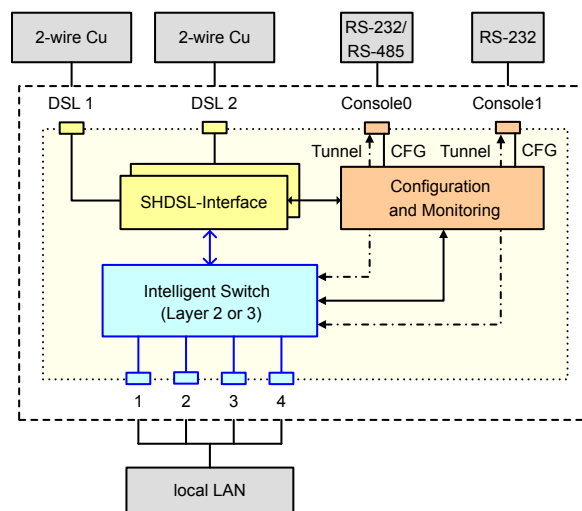

Figure 1: Block diagram of 500NMD02

Characteristics

For documentation purposes, the Ethernet ports are labeled from 1 to 4. There is no specific uplink port. All ports are equal in function. The SHDSL port is connected through a pluggable screw connector. Link and speed status of each Ethernet and the SHDSL ports are displayed by status indicators (refer to Connectors and Indicators).

The switch learns Ethernet addresses by analyzing received frames and stores them in a lookup-table (max. 2048 entries), which is used to forward frames only to the correct port. If it is broad- or multicast or if the target address is not found in the lookup-

table, a received frame is forwarded to all ports except the receiving one. If an entry in the lookup-table is not refreshed by an incoming frame with the specific source address, it is aged out within a maximum of 304 seconds (by default, value is configurable).

Regarding IEEE 802.1Q VLAN frames, the switch can be configured to VLAN or transparent mode. In transparent mode the switch will never change any frame or TAG of a frame; in VLAN mode it can be configured to support several applications like trunk or access ports.

Quality-of-Service is supported by the switch if an IEEE 802.1p compliant frame format is used. The switch can separate frames into up to four queues, which can be configured to priority based or weighted-fair queuing.

The 500NMD02 uses a wide range power supply and works with a voltage from 24 to 60 V.

The component itself, the Ethernet ports as well as the SHDSL connection, the RS-232 interface and the extension bus interface (Ext) are hot-plug capable.

Topology

The 500NMD02 provides a total of six ports for use with end devices, switches, bridges, hubs and routers. Star, ring or line topologies can easily be built by this family of switches.

Redundant topologies are automatically detected and handled by the Rapid Spanning Tree Protocol (RSTP) or the Multiple Spanning Tree Protocol (MSTP). This is fully backward compatible with the wide-spread Spanning Tree Protocol (STP).

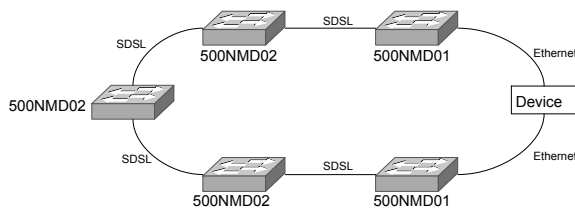

Figure 2: Typical topology for use with 500NMD02

Management and Configuration

Management and configuration of the 500NMD02 can be done by Telnet, Secure Shell (SSH), SNMP, RS-232 or Web-interface. All methods can be used to either read or write parameters of the device.

Additionally the interface and alarm state of the device can be monitored by IEC 60870-5-101 or -104.

An existing configuration can be saved as well as restored. The configuration can also be stored to an external configuration stick (500NMA01), which supports the simple exchange of a device without trained personnel.

By default, the IP address for the configuration of a 500NMD02 switch is 10.0.0.2 with a subnet mask of 255.0.0.0 and a gateway of 10.0.0.1. Connections for configuration purposes may be accepted through any

interface. All Ethernet ports are administratively up in default state.

The preconfiguration for the RS-232 interface is baudrate 57600, 8 databits, no parity, 1 stopbit (57600, 8N1). The command-line interpreter for configuration via this interface can be accessed by any terminal software (e.g. Hyperterminal).

Ports

All ports of the device can be disabled or enabled by configuration. Furthermore, the speed and duplex of any port can be set according to its capabilities. This is 10 or 100 Mbps, Full or Half duplex for the Ethernet ports. It is also possible to use an auto-detect setting.

The switch supports multiple additional features, like port mirroring, bandwidth control, or quality of service.

Alerts, Notifications and Logging

The 500NMD02 provides Syslog and SNMP capabilities to send alerts and notifications to one or more predefined destinations. There is also a relay for configurable out-of-band alerts.

For each Syslog server entry a severity can be entered to filter outgoing messages.

A system log stores critical messages. The log includes a timestamp either by system uptime, or date and time if a time server is configured.

For Syslog and local logging, a SNTP time server can be used to synchronize clocks and to enable the generation of date and time timestamps instead of uptime referencing messages.

Redundancy Support

The redundancy protocols Spanning Tree Protocol (STP), Rapid Spanning Tree Protocol (RSTP) and Multiple Spanning Tree Protocol (MSTP) are fully supported. Without configuration RSTP is enabled for all ports. Switching from RSTP to STP is done automatically to ensure the compatibility to existing STP installations.

For every port, the parameters can be adjusted separately. This includes port priority for root bridge control as well as point-to-point and edge connection settings. A global bridge priority is also settable.

The protocol Ethernet Ring Protection Switching (ERPS) is supported as well.

Security

Access to the configuration interfaces of the 500NMD02 is controlled by a two-level password protection. The first level enables the user to access parameters in read-only mode and has to be entered as soon as a connection is established. To read and write parameters, the device has to be put in a configuration mode that requires an additional password. Any password can be disabled.

Some security sensitive information, such as the configuration file, are not available in read-only mode.

Besides the two-level password protection, users may be authenticated by a standard RADIUS server.

Devices can be authenticated via optional IEEE 802.1X support using a central authentication server (RADIUS).

Access control lists provide packet filtering and class-of-service rewriting on a per port basis.

Technical data

In addition to the EDS500 series general technical data, the following applies:

General standards	
Safety tested according to	• IEC 60950-1
Environmental conditions tested according to	• ETSI EN 300 019-1-3 class 3.4 • ETSI EN 300 019-2-8 test condition T8.1 • IEC 61850-3 • IEC 60255-21-1 class 2 • IEC 60255-21-2 class 1 • IEC 60721-3-3 class 3M5 • EN 50125-3 class T1 and T2
Electromagnetic compatibility (EMC) tested according to	• IEC 61000-6-2 • IEC 61000-6-4 • ETSI EN 300 386 • EN 50121-4 • IEC 61850-3

Environmental conditions - climatic	
Nominal operating temperature range EN 60068-2-1, EN 60068-2-2, EN 60068-2-14	-40 °C... 80 °C
Relative humidity EN 60068-2-30	5... 95 % (non condensing)
Railway applications EN 50125-3	climatic class T1 and T2

Environmental conditions - mechanical	
Vibration sinusoidal, Test Fc, IEC 60068-2-6	1.2 mm (5... 9 Hz) 4 m/s ² (9... 200 Hz) 1 octave/ min, 5 cycles per axis EN 300 019-2-8 class T8.1 0.075 mm (10... 60 Hz) 9.8 m/s ² (60... 150 Hz) 1 octave/ min, 1 cycle per axis IEC 60255-21-1 class 2
Shock and Bump, Test Ea, IEC 60068-2-27	300 m/s ² , 18 ms 3 shocks per direction IEC 60721-3-3 class 3M5 50 m/s ² , 11 ms 100 shocks per direction EN 300 019-2-8 class T8.1 100 m/s ² , 16 ms 1000 shocks per direction IEC 60255-21-2 class 1
Vibration broad-band random, Test Fh, IEC 60068-2-64	1.5 m/s ² (5... 100 Hz) 30 min per axes EN 300 019-2-8 class T8.1
Hammer test, Test Eh, IEC 60068-2-75	energy: 0.2 J

Emission test

Radiated emissions - enclosure ports (30 Mhz to 1 GHz), CISPR 16-2-3/ EN 55016-2-3	EN 55022/ CISPR 22 class A
Radiated emissions - enclosure ports (1 to 3 GHz), CISPR 16-2-3/ EN 55016-2-3	EN 55022/ CISPR 22 class A

Immunity test

Electrostatic discharge, IEC 61000-4-2	8 kV air / 6 kV contact (level 3), criterion A
Radiated radio-frequency electromagnetic field, IEC 61000-4-3	20 V/m (level x), criterion A
Impulse magnetic field, IEC 61000-4-9	100 A/m (level 3), criterion A

Mean time between failure (MTBF)

Calculation according to MIL-Handbook-217F	110 years @ 40 °C
--	-------------------

Mechanical layout

Dimensions	99 x 68 x 115 mm (H x W x D)
Mounting	35 mm DIN-rail
Cooling	thermal convection (no moving parts)
Weight	325 g

Power supply input (X1)

Operating voltage	24... 60 V DC -20%... +20%
Power consumption (typical)	6 W (all ports active)
Current demand (peak)	540 mA @ 24 V / 220 mA @ 60 V
Plug type	Phoenix Contact MSTBT 2.5/4-ST
Reverse polarity protection	yes
Circuit classification	SELV (acc. IEC 60950-1)
Galvanic isolation	1.5 kV isolation voltage
Overvoltage protection	line to earth ±4 kV, line to line ±2 kV
Electrical fast transient / Burst, IEC 61000-4-4	4 kV line to earth, 2 kV line to line (level 4), criterion A
Surge 1.2/50 µs, IEC 61000-4-5	4 kV line to earth, 2 kV line to line (level 4), criterion A
Conducted, common mode disturbances in the frequency range 0 Hz to 150 kHz, IEC 61000-4-16	30 V continuous disturbance/ 300 V short duration disturbance (level 4), criterion A
Conducted emissions - asymmetrical DC ports, common mode (0.15 MHz to 30 MHz)	EN 55032/ CISPR 32 class A IEC 61000-6-4

Ethernet interfaces (Port1 - Port4)	
Electrical specification	IEEE 802.3
Protocol	Fast Ethernet, Auto negotiation, Auto sense
Data rate	100 Mbps, 10 Mbps or auto
Duplex	full duplex, half duplex or auto
Transmission / Network termination	MDI, MDI-X or auto
Cable	shielded CAT5e cable (or better), maximum length: 100m
Plug type	RJ-45 (8P8C)
Circuit classification	TNV-1 (acc. IEC 60950-1)
Galvanic isolation	1.5 kV isolation voltage
Overvoltage protection	Shield to earth ± 4 kV
Electrical fast transient / Burst, IEC 61000-4-4	4 kV (level 4), criterion A
Surge 1.2/50 μ s, IEC 61000-4-5	4 kV (level 4), criterion A
Conducted disturbances, induced by radio-frequency fields, IEC 61000-4-6	10 V (level 3), criterion A
Conducted, common mode disturbances in the frequency range 0 Hz to 150 kHz, IEC 61000-4-16	30 V continuous disturbance/ 300 V short duration disturbance (level 4), criterion A
Conducted emissions - symmetrical network ports (0.15 MHz to 30 MHz)	EN 55032/ CISPR 32 class B

Serial interfaces (Con0 - Con1)	
Electrical specification	Con0: ITU-T V.24, EIA RS-232 or EIA RS-422/485, Con1: ITU-T V.24, EIA RS-232
Data rate	50 bps... 230.4 kbps
Plug type	RJ-12 (6P6C)
Cable	shielded RS-232 cable, up to 3 m
Adapter cable	500CAB06 1KGT038912R0001: RS-232 cable, RJ12 to SubD9F (DTE-PC)
Circuit classification	SELV (acc. IEC 60950-1)
Galvanic isolation	no
Overvoltage protection	Shield to earth ± 4 kV
Electrical fast transient / Burst, IEC 61000-4-4	4 kV (level 4), criterion A
Surge 1.2/50 μ s, IEC 61000-4-5	4 kV (level 4), criterion A
Conducted disturbances, induced by radio-frequency fields, IEC 61000-4-6	10 V (level 3), criterion A
Conducted, common mode disturbances in the frequency range 0 Hz to 150 kHz, IEC 61000-4-16	30 V continuous disturbance/ 300 V short duration disturbance (level 4), criterion A

DSL interface (X3 - X4)	
Electrical specification	ETSI TS 101 524, ITU-T G.991.2, IEEE 802.3-2008 Cl. 63
Protocol	ETSI SDSL (ETSI TS 101 524 V 1.2.1) ETSI SDSL.bis (ETSI TS 101 524 V 1.2.2) ITU-T G.shdsl (ITU-T G.991.2) ITU-T G.shdsl.bis (ITU-T G.991.2) ITU-T G.hs (ITU-T G.994.1) IEEE EFM (IEEE 802.3)
Data rate	up to 15 Mbps
Plug type	Phoenix Contact MSTBT 2,5/3-ST
Cable	shielded, twisted telecommunications cable, up to 25 km with cable diameter 0.8 mm
Circuit classification	TNV-1 (acc. IEC 60950-1)
Auto crossover detection	yes
Galvanic isolation	3 kV isolation voltage
Overvoltage protection	Shield to earth ± 6 kV, line to earth ± 6 kV, line-line ± 6 kV
Electrical fast transient / Burst, IEC 61000-4-4	4 kV (level 4), criterion A
Surge 1.2/50 μ s, IEC 61000-4-5	6 kV line to earth, 6 kV line to line (level x), criterion B
Surge 10/700 μ s, IEC 61000-4-5	6 kV line to earth, 6 kV line to line (level x), criterion B
Conducted disturbances, induced by radio-frequency fields, IEC 61000-4-6	10 V (level 3), criterion A
Conducted, common mode disturbances in the frequency range 0 Hz to 150 kHz, IEC 61000-4-16	30 V continuous disturbance/ 300 V short duration disturbance (level 4), criterion A

Ext Connector	
Connector	Proprietary
For usage of the configuration stick 500NMA01 to save the configuration to an external media.	

Alarm output (X2)	
Type of switch	Toggle (potential free)
Switching voltage	60 VDC / 25 VAC
Switching current	500 mA
Plug type	Phoenix Contact MSTBT 2,5/4-ST
Circuit classification	SELV (acc. IEC 60950-1)
Overvoltage protection	line to earth ± 4 kV, line to line ± 2 kV
Electrical fast transient / Burst, IEC 61000-4-4	4 kV (level 4), criterion A
Surge 1.2/50 μ s, IEC 61000-4-5	4 kV (level 4), criterion A

Alarm output (X2)	
Conducted disturbances, induced by radio-frequency fields, IEC 61000-4-6	10 V (level 3), criterion A
Conducted, common mode disturbances in the frequency range 0 Hz to 150 kHz, IEC 61000-4-16	30 V continuous disturbance/ 300 V short duration disturbance (level 4), criterion A

Switching	
Flow Control	Full duplex flow control according to IEEE 802.32005 An. 31B and IEEE 802.3x-1997 Half duplex back pressure
Max. Frame size	1552 Bytes
Quality of Service	IEEE 802.1p Tag based priority
MAC Lookup Table	Max. 2048 entries Max. 304 s hold time
Switching Mode	Store and forward

Supported Protocols	
Telecontrol Comm.	IEC 60870-5-101 IEC 60870-5-104
Link Layer Discovery	IEEE 802.1AB-2009
Spanning Tree	IEEE 802.1D-2004
Class of Service	IEEE 802.1p
VLAN Tagging	IEEE 802.1Q-2005
Network Access Ctrl.	IEEE 802.1X-2001
UDP	RFC-768
IP	RFC-791
ICMP	RFC-792
TCP	RFC-793
ARP	RFC-826
Telnet	RFC-854
SNMP	RFC-1155 to RFC-1157 RFC-1901 to RFC-1908
SNMP MIB-II	RFC-1213
TFTP	RFC-1350
CIDR	RFC-1519
RIP	RFC-2453
HTTP	RFC-2616
L2TP	RFC-2661
RADIUS	RFC-2865
Syslog	RFC-3164
SSHv2	RFC-4254 and RFC-5251

Supported Protocols	
SNTP	RFC-4330

Ordering information	
500NMD02 R0002	1KHW025097R0002

Accessories ordering information 500NMA01 configuration adapter	
500NMA01 R0001	1KHW027870R0001

Accessories ordering information 500CAB06 RS-232 adapter cable RJ12 to SubD9F (DTE-PC)	
500CAB06 R0001	1KGT038912R0001