

WHITEHALL TOWNSHIP

DECK GUIDE

(see DCA-6 Prescriptive Deck Guide 2018)

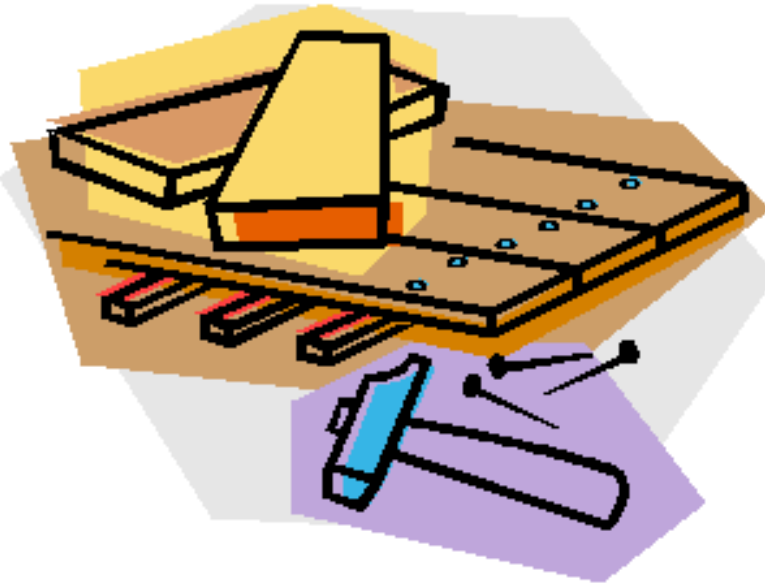

PERMIT FEES

- Deck (over 48" above grade): \$ 224.50
- Deck (any portion under 48" above grade): \$ 299.50
(Pursuant to Contracted Agent fee schedule)

ATTENTION: There is a non-refundable application fee due at time of submission. The fee for **RESIDENTIAL** is \$ 60.00. **NO PERMIT WILL BE ACCEPTED WITHOUT THE APPLICATION FEE.** Additional fees may be due at permit issuance. Note: Fees are subject to change without notice

*Please provide a valid email address on your application for correspondence. If our third-party inspection agency, zoning officer, or permit clerk needs additional information from you they will reach out via email.

NOTE: THIS IS A GUIDE ONLY!
FOR DETAILED INFORMATION CONTACT THE TOWNSHIP OR THE BUILDING INSPECTOR, AS ADDITIONAL REQUIREMENTS MAY PERTAIN TO YOUR DECK.

**WHITEHALL TOWNSHIP
BUREAU OF PLANNING, ZONING & DEVELOPMENT
DECK CODE GUIDE**

Whitehall Township has assembled the information contained in this “Code Guide” to assist homeowners when planning to construct a deck on their property. It contains general information regarding zoning and setback issues as well as materials and types of construction permitted by Township Ordinances.

While we hope that this information is most helpful to you, please remember that it is a ***guide*** only, and if you have additional questions beyond the information contained herein, you should contact either the Zoning Officer at (610-437-5524 x1155) or the Building Inspector at Keycodes Inspection Agency at (610-866-9663).

Please also know that the Township’s hours are 8:00 a.m. to 4:00 p.m. Monday thru Friday, and all permit applications must be considered complete before review. This means all plans and specifications must be included with the application, contractor’s workmen’s compensation coverage information submitted, and plot plan included, and the non-refundable application fee be received at the time of submission.

Please note that no construction materials are ever permitted to be stored on any township street.

Definition

Decks in this code guide will refer to all such structures constructed either on or above ground, of lumber or other approved materials.

Permits and Plans

A building permit application must be submitted with complete construction details (including but not limited to) ledger, flashing, footer, framing, hardware, hand and guardrail details. A detailed plot plan showing property lines, easements, size of deck and setbacks from all property lines must be submitted with the permit application. No deck shall be constructed, installed, enlarged, or altered unless and until the appropriate permit has been secured from the Bureau of Planning, Zoning and Development. A building permit must be submitted **by the individual doing the work** and must include detailed plans as outlined in this guide; and if involving a contractor, be accompanied by the appropriate Workmen's Compensation insurance information. If any information is missing, the application will not be accepted.

Location

According to the Whitehall Township Zoning Ordinance, all decks, porches, patios, and similar structures shall:

- Be permitted within the rear and side yard areas, provided that same shall not exceed one third (1/3) of the rear yard setback required for the district in which the property is located or shall not be closer than ten (10) feet to the rear property line, whichever is greater.
 - Not be enclosed unless the deck, porch or patio meets all the structural and setback requirements for a principal structure in the zoning district where property is located.
 - No deck, patio, porch or similar structure shall be permitted in the front yard.
 - Decks for swimming pools must also adhere to the regulations contained in the Whitehall Township Swimming Pool Code Guide, as well as any other applicable regulations.
- * Shall not be permitted to encroach in any easement areas dedicated to Whitehall Township.
- * Special requirements may apply to properties located in a flood zone; it is your responsibility as a property owner to be aware of flood zones on your property. For more information visit msc.fema.gov or floodsmart.gov.

Plans and Specifications

General Notes

Decks constructed according to this guide are not to be used for hot tub support. Decks for hot tubs have heavy design loads that are outside the scope of this guide and generally require a structural engineer's sealed design.

Decks shall not be attached to house overhangs (cantilevers), cantilevered box or bay windows, brick or stone veneers, or chimneys. These decks would require self supporting construction methods or a design stamp by a Pennsylvania licensed engineer.

Footings / Piers

Footings / Piers shall be properly sized for the design and loading of the deck. Post holes for pier footings must be excavated to a minimum of thirty-six (36) inches in depth below grade. If within 5' of foundation depth shall be as deep as house footer. Piers must be sized per Section R507.3 or by a registered design professional. Locations of posts will be determined by the size of the deck proposed and must be indicated on plans.

Framing

Beam and joist size must be clearly indicated on plans. Ledger board shall be secured according to the chart provided within (Please see Span Chart Table – R 507.9.1.3(1)). Alternative fasteners are allowed if specifically tested for ledgers and will require submittal of test data.

No screws are permitted in framing unless approved for the use such as Simpson SDS screws.

All deck measurements - widths and lengths - must be clearly indicated on plans, so the sizes of proposed materials can be checked for the proper span.

Railings

Railings are required around all elevated (30" or more above ground level) deck areas, at a minimum of thirty-six (36) inches height, and maximum spacing permitted between balusters or spindles may not permit a 4-inch sphere. Handrails are also required on stairs with four or more step and must be continuous for the full length of the stairs. Handrail ends shall terminate back into a wall or post.

Deck Boards

Must be a minimum thickness of 5/4" or plastic composite installed in conformance with the manufacturer's installation instructions.

REMEMBER: Applicant must call PA ONE CALL (8-1-1) 3 days prior to any excavation.

Materials

All wood decks must be constructed of pressure treated lumber or other approved material; and all fasteners, nails, etc. must be of galvanized steel. Teco nails should be used. Roofing nails shall ***not*** be used.

Inspections

A minimum of three (3) inspections are required for all decks; post hole inspection for the footings prior to pouring concrete; ledger board must be installed and flashed at the time of footing inspection; framing inspection when all the beams and joists have been placed; final inspection when work is complete. **Note:** framing can be done at the same time as the Final inspection if the framing is not less than three (3) feet above grade. Please know that Keycodes Inspection Agency requires a minimum of forty-eight (48) hour notice for all inspection requests. You must have the permit number, type of inspection needed and address of job location when calling to schedule an inspection. If there is a contractor performing the work, *they* must request the inspections. Additional fees may be charged if inspections are requested for work not yet complete.

Furthermore, if a contractor is constructing said deck, appropriate documentation of Workmen's Compensation insurance coverage must be provided to the Township, pursuant to PA Workmen's Compensation Laws, which ***must*** accompany building permit application at time of submission.

Typical Deck Details

Based on the 2018 International Residential Code
and Pennsylvania Uniform Construction Code Amendments
(Designed and Printed February 2022)

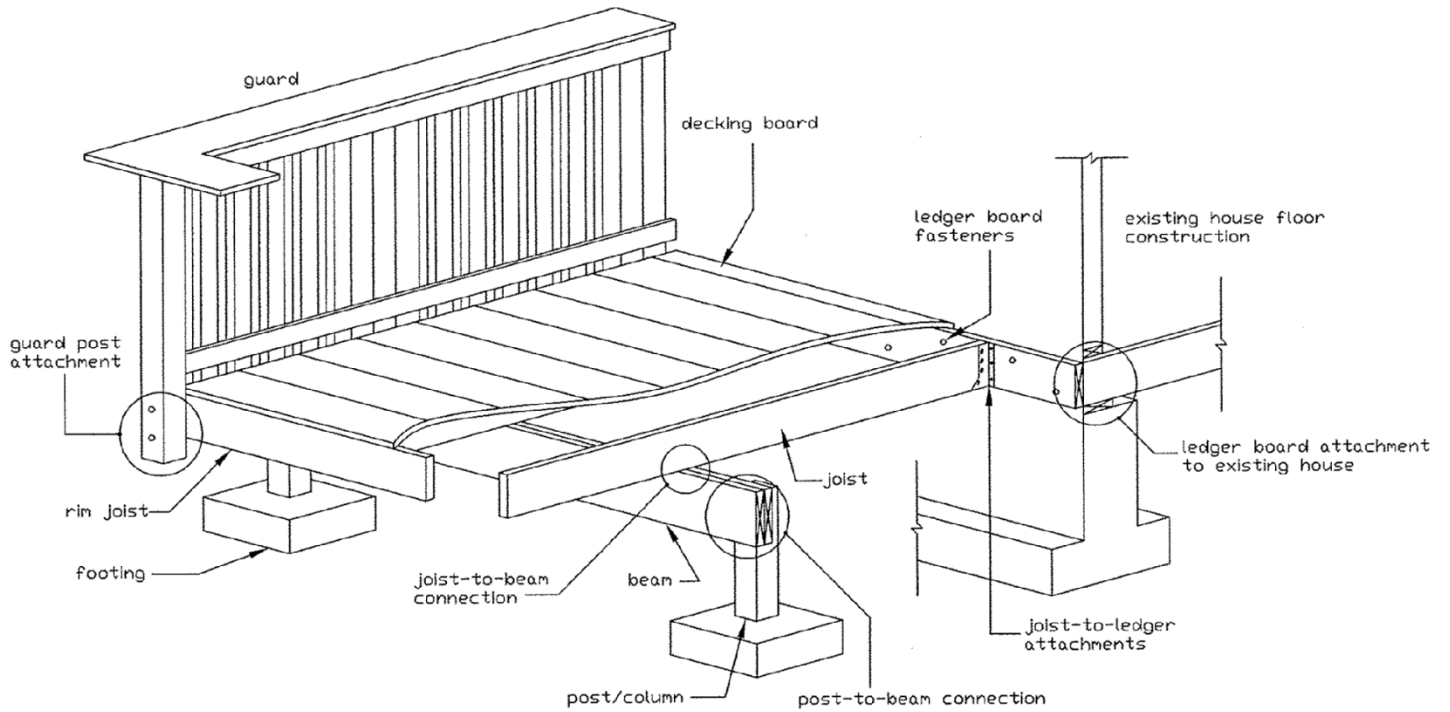

GENERAL INFORMATION

1. Definition: Deck – An exterior floor system supported on at least two opposing sides by an adjoining structure and/or posts, piers, or other independent supports.
2. All wood in contact with the ground, embedded in concrete in direct contact with the ground or embedded in concrete exposed to the weather that supports permanent structures intended for human occupancy shall be approved pressure-preservative treated wood suitable for ground contact use. [R317.1.2]
3. Wood/plastic composites used in deck boards, stair treads, handrails and guardrail systems shall comply with the provisions of ASTM D 7032 and shall be installed per the manufacturer's instructions. [R507.3]
4. Lag screws, bolts and washers shall be hot-dipped galvanized or stainless steel.
5. All screws and nails shall be hot-dipped zinc-coated galvanized steel, stainless steel, silicon bronze or copper. All steel bolts shall be of one-half-inch diameter or larger. [R317.3]
6. To resist corrosion, fasteners shall meet the requirements of ASTM A 153. [R317.3]
7. All connectors (post anchors, joist hangers, post-to-beam connectors) shall be galvanized or stainless steel. [R317.3.1]
8. Where exterior decks attach to a wall or floor assembly of wood-frame construction, corrosion-resistant metal flashing or approved non-metallic material shall be installed to prevent water from contacting the house band joist. [R703.4/R507.2 footnote a]
Bare aluminum shall not be used in direct contact with lumber treated with preservatives that contain copper (such as ACQ, Copper Azole or ACZA)
9. All of the following inspections are required during construction of deck:
 - Footing inspections are required before the concrete is poured. All holes must be cleaned and free from loose dirt.
 - Framing inspections must be completed before the decking may be attached, unless otherwise noted.
 - Final inspection shall be scheduled when all construction of the deck has been completed.
 - NOTE: ALL INSPECTIONS ARE MANDATORY BY LAW. FAILURE TO OBTAIN THE INSPECTIONS MAY CAUSE VIOLATIONS AND FINES.
10. It shall be the duty of the permit holder or their agent to notify the building official that such work is ready for inspection. It shall be the duty of the person requesting any inspections required by this code to provide access and means for inspection of such work.
11. All inspections must be made at least 48 hours in advance. All construction documents shall be on the jobsite and provided to inspector upon request.
12. Decks may not be occupied until all inspections have been completed and a final approval (in the form of a certificate of occupancy) has been issued by the Building Code Official.

FOOTINGS

All footers must be a minimum of 36" below grade and bear on undisturbed, natural soil. Deck footings closer than 5'-0" to an existing exterior house wall must bear at the same elevation as the existing footer of the house. **The size of footings supporting piers and columns shall be based on tributary load and the allowable soil pressure of 1500 psf** (unless soil test data is provided). [R403.1.1] Do not construct footings over utility lines or enclosed meters - Call 811 before you dig.

To determine pier minimum width, first calculate tributary area supported by each column/post (see Figure 1).

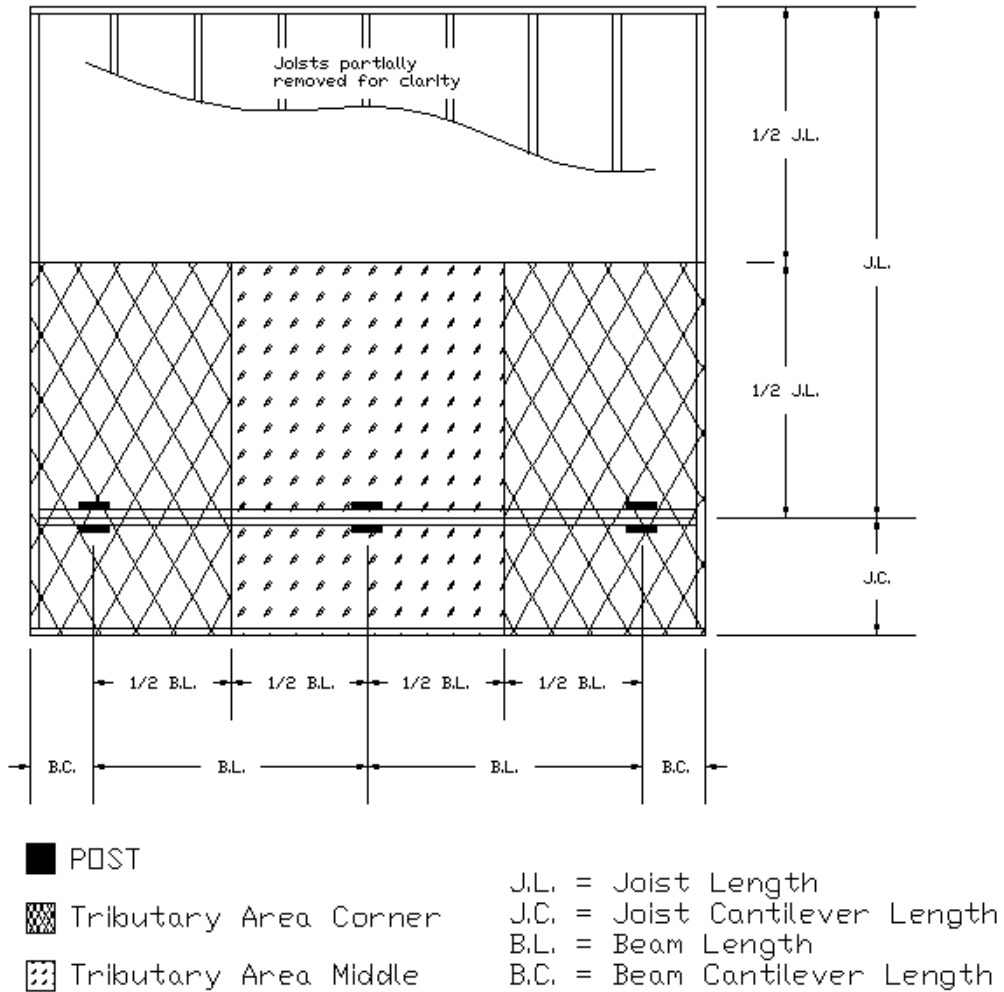

Then, use the tributary area to find required footing size in Table 1 (on following page):

TABLE 1

Live Load (psf)	Tributary Area (sq.ft.)	Load-bearing Value of Soils = 1,500 psf		
		Side of square footing (inches)	Diameter of round footing (inches)	Thickness (inches)
40	20	12	14	6
	40	14	16	6
	60	17	19	6
	80	20	22	7
	100	22	25	8
	120	24	27	9
	140	26	29	10
	160	28	31	11

(Interpolation permitted. Extrapolation not permitted)

JOIST SIZING AND SPAN

Maximum allowable spans for wood deck joists shall be in accordance with Table 1 and the Figure 2 below. Deck joists are permitted to cantilever not greater than one-fourth of the actual, adjacent span. [R507.5] Joist framing into the side of a ledger board or beam shall be supported by approved joist hangers. Joists bearing on a beam shall be connected to the beam to resist lateral displacement. [R507.7]

TABLE 2
DECK JOIST SPANS FOR COMMON LUMBER SPECIES^f (ft. - in.)

SPECIES ^a	SIZE	SPACING OF DECK JOISTS WITH NO CANTILEVER ^b			SPACING OF DECK JOISTS WITH CANTILEVERS ^c		
		(inches)			(inches)		
		12	16	24	12	16	24
Southern pine	2 x 6	9-11	9-0	7-7	6-8	6-8	6-8
	2 x 8	13-1	11-10	9-8	10-1	10-1	9-8
	2 x 10	16-2	14-0	11-5	14-6	14-0	11-5
	2 x 12	18-0	16-6	13-6	18-0	16-6	13-6
Douglas fir-larch ^d , hem-fir ^d , spruce-pine-fir ^d	2 x 6	9-6	8-8	7-2	6-3	6-3	6-3
	2 x 8	12-6	11-1	9-1	9-5	9-5	9-1
	2 x 10	15-8	13-7	11-1	13-7	13-7	11-1
	2 x 12	18-0	15-9	12-10	18-0	15-9	12-10
Redwood, western cedars, ponderosa pine ^e , red pine ^e	2 x 6	8-10	8-0	7-0	5-7	5-7	5-7
	2 x 8	11-8	10-7	8-8	8-6	8-6	8-6
	2 x 10	14-11	13-0	10-7	12-3	12-3	10-7
	2 x 12	17-5	15-1	12-4	16-5	15-1	12-4

a. No. 2 grade with wet service factor.

b. Ground snow load, live load = 40 psf, dead load = 10 psf, $L/\Delta = 360$

c. Ground snow load, live load = 40 psf, dead load = 10 psf, $L/\Delta = 360$ at main span, $L/\Delta = 180$ at cantilever with a 220-pound point load applied to end.

d. Includes incising factor.

e. Northern species with no incising factor.

f. Cantilevered spans not exceeding the nominal depth of the joist are permitted.

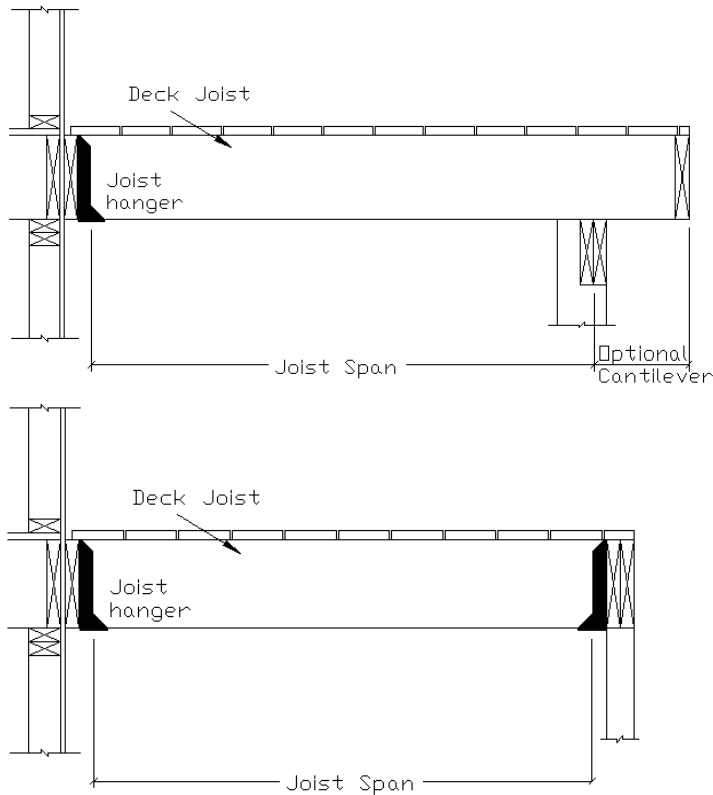

Figure 2

BEAM SIZE AND ASSEMBLY REQUIREMENTS

Maximum allowable spans for wood deck beams shall be in accordance with Table 2. Beam spans are measured to the centerline of each post. Beam plies shall be fastened with two rows of 10d nails minimum at 16 inches on center along each edge. Beams shall be permitted to cantilever at each end up to one-fourth of the actual beam span. Splices of multi-span beams shall be located at interior post locations. [R507.5/2018 IRC Table 507.5] The ends of each beam shall have not less than 1.5 inches of bearing on wood or metal and not less than 3 inches on concrete or masonry. [R507.7] Beams may not be supported on deck ledgers or band joists. [R507.2.1] If using engineered lumber, an engineer's seal is required upon submission. [R301.1.3]

TABLE 3
DECK BEAM SPAN LENGTHS (feet - inches)

SPECIES ^c	SIZE ^d	DECK JOIST SPAN LESS THAN OR EQUAL TO:						
		(feet)						
		6	8	10	12	14	16	18
Southern pine	1 - 2 x 6	4-11	4-0	3-7	3-3	3-0	2-10	2-8
	1 - 2 x 8	5-11	5-1	4-7	4-2	2-10	3-7	3-5
	1 - 2 x 10	7-0	6-0	5-5	4-11	4-7	4-3	4-0
	1 - 2 x 12	8-3	7-1	6-4	5-10	5-5	5-0	4-9
	2 - 2 x 6	6-11	5-11	5-4	4-10	4-6	4-3	4-0
	2 - 2 x 8	8-9	7-7	6-9	6-2	5-9	5-4	5-0
	2 - 2 x 10	10-4	9-0	8-0	7-4	6-9	6-4	6-0
	2 - 2 x 12	12-2	10-7	9-5	8-7	8-0	7-6	7-0
	3 - 2 x 6	8-2	7-5	6-8	6-1	5-8	5-3	5-0
	3 - 2 x 8	10-10	9-6	8-6	7-9	7-2	6-8	6-4
	3 - 2 x 10	13-0	11-3	10-0	9-2	8-6	7-11	7-6
	3 - 2 x 12	15-3	13-3	11-10	10-9	10-0	9-4	8-10
Douglas fir-larch ^e , hem-fir ^e , spruce-pine-fir ^e , redwood, western cedars, ponderosa pine ^f , red pine ^f	3 x 6 or 2 - 2 x 6	5-5	4-8	4-2	3-10	3-6	3-1	2-9
	3 x 8 or 2 - 2 x 8	6-10	5-11	5-4	4-10	4-6	4-1	3-8
	3 x 10 or 2 - 2 x 10	8-4	7-3	6-6	5-11	5-6	5-1	4-8
	3 x 12 or 2 - 2 x 12	9-8	8-5	7-6	6-10	6-4	5-11	5-7
	4 x 6	6-5	5-6	4-11	4-6	4-2	3-11	3-8
	4 x 8	8-5	7-3	6-6	5-11	5-6	5-2	4-10
	4 x 10	9-11	8-7	7-8	7-0	6-6	6-1	5-8
	4 x 12	11-5	9-11	8-10	8-1	7-6	7-0	6-7
	3 - 2 x 6	7-4	6-8	6-0	5-6	5-1	4-9	4-6
	3 - 2 x 8	9-8	8-6	7-7	6-11	6-5	6-0	5-8
	3 - 2 x 10	12-0	10-5	9-4	8-6	7-10	7-4	6-11
	3 - 2 x 12	13-11	12-1	10-9	9-10	9-1	8-6	8-1

a. Ground snow load, live load = 40 psf, dead load = 10 psf, L/Δ = 360 at main span, L/Δ = 180 at cantilever with a 220-pound point load applied to end.

b. Beams supporting deck joists from one side only.

c. No. 2 grade, wet service factor.

d. Beam depth shall be greater than or equal to depth of joists with a flush beam condition.

e. Includes incising factor.

f. Northern species. Incising factor not included.

g. Beam cantilevers are limited to the adjacent beam's span divided by 4.

DECK POST ALLOWABLE HEIGHTS

For single-level wood-framed decks, the deck post size shall be in accordance with Table 3 below. [R507.4]

TABLE 4
DECK POST HEIGHT^a

DECK POST SIZE	MAXIMUM HEIGHT ^a
4 x 4	8'
4 x 6	8'
6 x 6	14'

a. Measured to the underside of the beam.

b. Based on 40 psf live load.

c. The maximum permitted height is 8 feet for one-ply and two-ply beams.

The maximum permitted height for three-ply beams on post cap is 6 feet 9 inches.

DECK POST-TO-BEAM CONNECTIONS

Deck post-to-beam connections shall be by either approved post cap or the notching of a 6x6 post to allow the beam to rest directly on the post. The remaining portion of the 6x6 post shall be minimum 2-1/2" and shall use through-bolts with washers and nuts. [R507.5.2] See Figure 3 below.

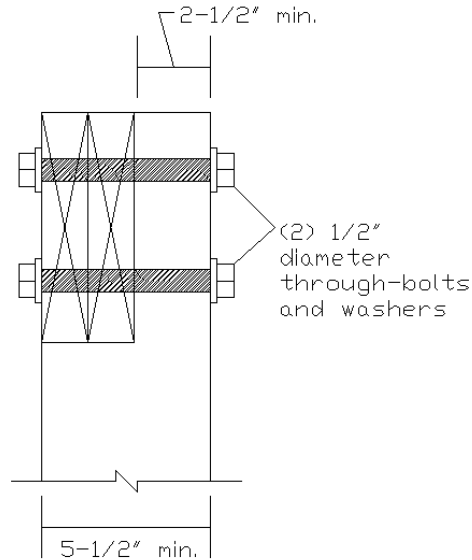

Figure 3

DECK POST-TO-FOOTING CONNECTIONS

Deck posts shall bear onto footings and be restrained to prevent lateral displacement at the bottom support. This may be achieved by using an approved manufactured connector or with a minimum 12-inch post embedment into concrete or soil surround pier. [R507.3]

BRACING

Exterior landings, decks, and stairs shall be positively anchored to the primary structure to resist both vertical and lateral forces or shall be designed to be self-supporting. Attachment shall not be accomplished by use of toenails or nails subject to withdrawal. [R507.8]

Freestanding decks shall require diagonal bracing both parallel and perpendicular to the beam at each post. If it is attached to the house in accordance with the information contained herein, then the bracing perpendicular to the house shall not be required.

LEDGER ATTACHMENT

The deck ledger shall be minimum 2-inch by 8-inch nominal pressure-preservative-treated southern pine, incised pressure-preservative-treated Hem-fir, or approved, naturally durable, No. 2 grade or better lumber. [R507.9.1.1] For any other grade or species, or other connection

details or loading conditions, the deck ledger connection shall be approved by a registered design professional. [R507.9.1.4]

Deck ledgers shall not support concentrated loads from beams or girders, nor shall be supported on stone or masonry veneer. [R507.2.1]

The band joist shall be minimum 2-inch-nominal, solid-sawn, spruce-pine-fir lumber or a minimum 1-inch by 9-1/2-inch dimensional, Douglas fir, laminated veneer lumber. Band joists shall be fully supported by a wall or sill plate below. [R507.9.1.2]

The connection between a deck ledger and band joist shall be constructed with 1/2-inch lag screws or bolts with washers in accordance with Table 4. Lag screws, bolts and washers shall be hot-dipped galvanized or stainless steel. The removal of siding and installation of flashing is required between the house and the ledger. NOTE: YOU MAY NOT ATTACH LEDGER BOARDS TO EXISTING CANTILEVERS, OPEN WEB TRUSSES OR STONE OR MASONRY VENEER. If these conditions occur, the deck must be freestanding.

TABLE 5
DECK LEDGER CONNECTION TO BAND JOIST^{a, b}
(Deck live load = 40 psf, deck dead load = 10 psf, snow load ≤ 40 psf)

CONNECTION DETAILS	JOIST SPAN						
	6' and less	6'1" to 8'	8'1" to 10'	10'1" to 12'	12'1" to 14'	14'1" to 16'	16'1" to 18'
	On-center spacing of fasteners						
1/2-inch diameter lag screw with 1/2-inch maximum sheathing ^{c, d}	30	23	18	15	13	11	10
1/2-inch diameter bolt with 1/2-inch maximum sheathing ^d	36	36	34	29	24	21	19
1/2-inch diameter bolt with 1-inch maximum sheathing ^e	36	36	29	24	21	18	16

- a. Ledgers shall be flashed in accordance with Section R703.4 to prevent water from contacting the house band joist.
- b. Snow load shall not be assumed to act concurrently with live load.
- c. The tip of the lag screw shall fully extend beyond the inside face of the band joist.
- d. Sheathing shall be wood structural panel or solid sawn lumber.
- e. Sheathing shall be permitted to be wood structural panel, gypsum board, fiberboard, lumber or foam sheathing. Up to 1/2-inch thickness of stacked washers shall be permitted to substitute for up to 1/2-inch of allowable sheathing thickness where combined with wood structural panel or lumber sheathing.

The placement of lag screws and bolts in ledgers shall be in accordance with Table 6 and Figure 4 below. [R507.9.1.3]

TABLE 6
PLACEMENT OF LAG SCREWS AND BOLTS IN DECK LEDGERS AND BAND JOISTS

MINIMUM END AND EDGE DISTANCES AND SPACING BETWEEN ROWS				
	TOP EDGE	BOTTOM EDGE	ENDS	ROW SPACING
Ledger ^a	2 inches ^d	3/4 inch	2 inches ^b	1-5/8 inches ^b
Band Joist ^c	3/4 inch	2 inches	2 inches ^b	1-5/8 inches ^b

- a. Lag screws or bolts shall be staggered from the top to the bottom along the horizontal run of the deck ledger in accordance with Figure R507.2.1(1).
- b. Maximum 5 inches.
- c. For engineered rim joists, the manufacturer's recommendations shall govern.
- d. The minimum distance from bottom row of lag screws or bolts to the edge of the ledger shall be in accordance with Figure R507.2.1(1).

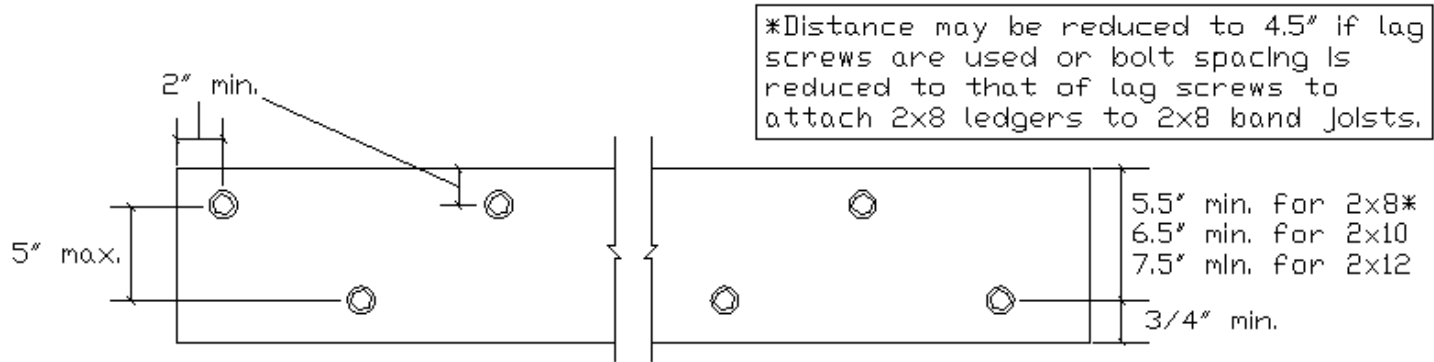

Figure 4

Where supported by attachment to an exterior wall, decks shall be positively anchored to the primary structure and designed for both vertical and lateral loads. [R507.8] Hold-down tension devices (such as the Simpson Strong-tie DTT2Z) shall be installed in not less than two locations per deck, within 24-inches of each end of the deck and each device shall have an allowable stress design capacity of not less than 1500 pounds (see example in Figure 5). If hold-down tension devices (such as the Simpson Strong-tie DTT1Z) are used, the minimum allowable stress design capacity of each device shall be 750 pounds and be installed in not less than four locations per deck (see example in Figure 10). [R507.9.2] Refer to manufacturer's installation instructions for specific information.

Where positive attachment cannot be verified during inspection, decks shall be self-supporting/free standing. [R507.1] Note: Tension devices used with I-joists must be installed per I-joist's manufacturer's engineered installation instructions.

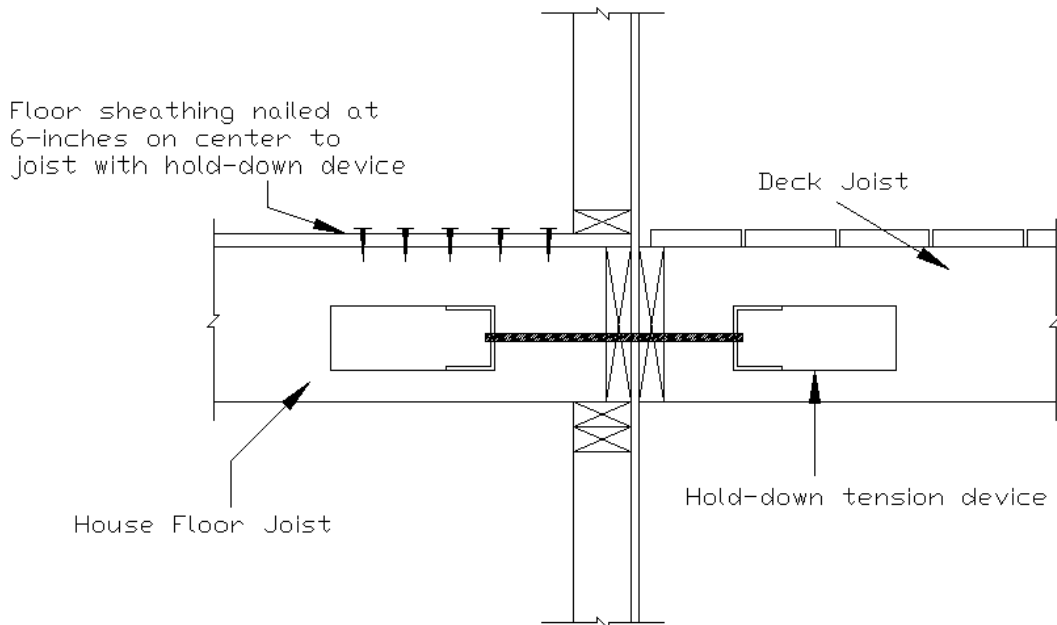

Figure 5

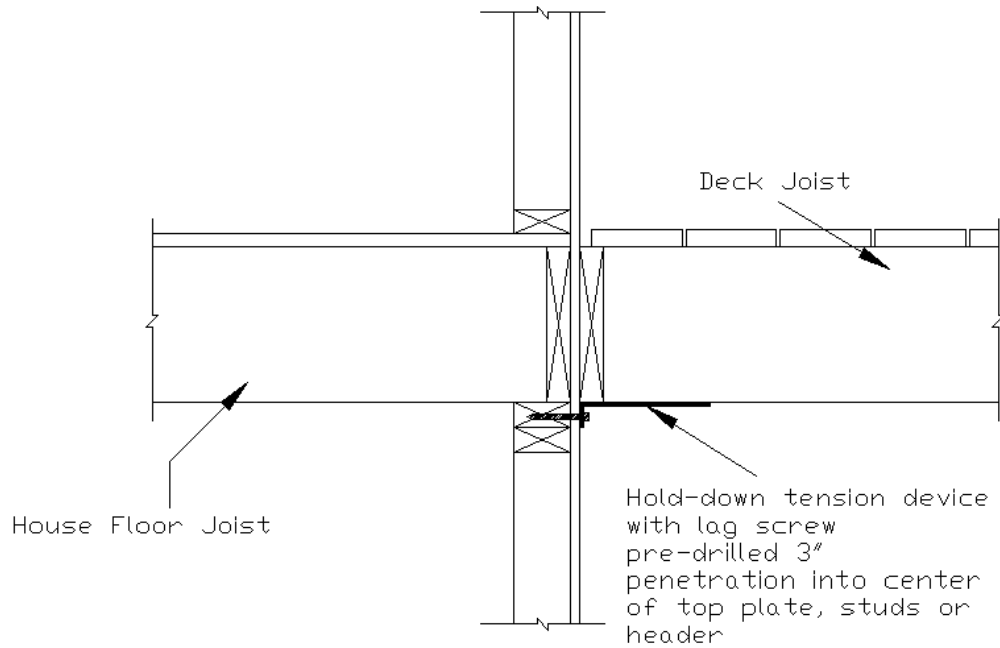

Figure 6

FRAMING AROUND A CANTILEVERED FLOOR SYSTEM

Attaching the ledger to a house overhang, chimney or bay window shall be prohibited. Use an alternate deck framing plan to achieve structural stability without fastening to the projection (see Figure 11 for example). [R507.9.1.2] Girders supporting deck joists shall not be supported by deck ledgers or band joists. [R507.9.1.1]

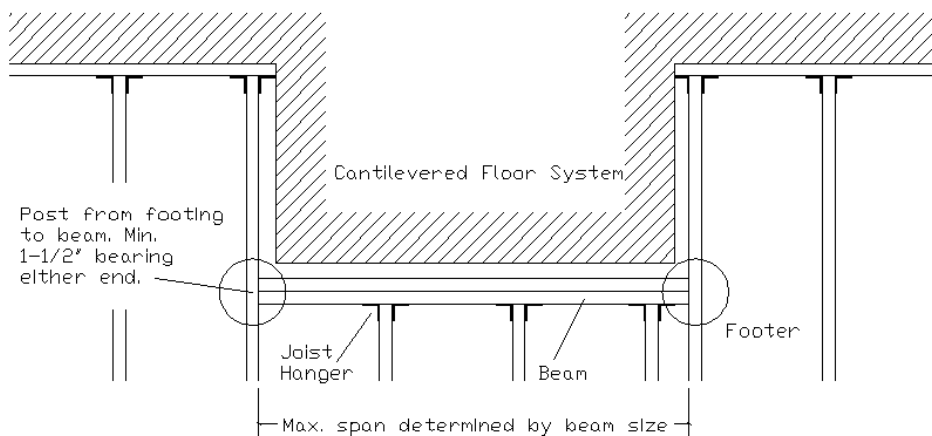

Figure 7

LATERAL RESTRAINTS AT SUPPORTS

Bearing locations and joist ends shall be provided with lateral restraints to prevent rotation. This can be accomplished by use of joist hangers or blocking between joists at a depth of at least 60 percent of joist depth. If accomplished by rim board, use (3) 10d nails or (3) No. 10x3-inch long wood screws to attach rim joist into each floor joist (see Figure 8). [R507.6.2]

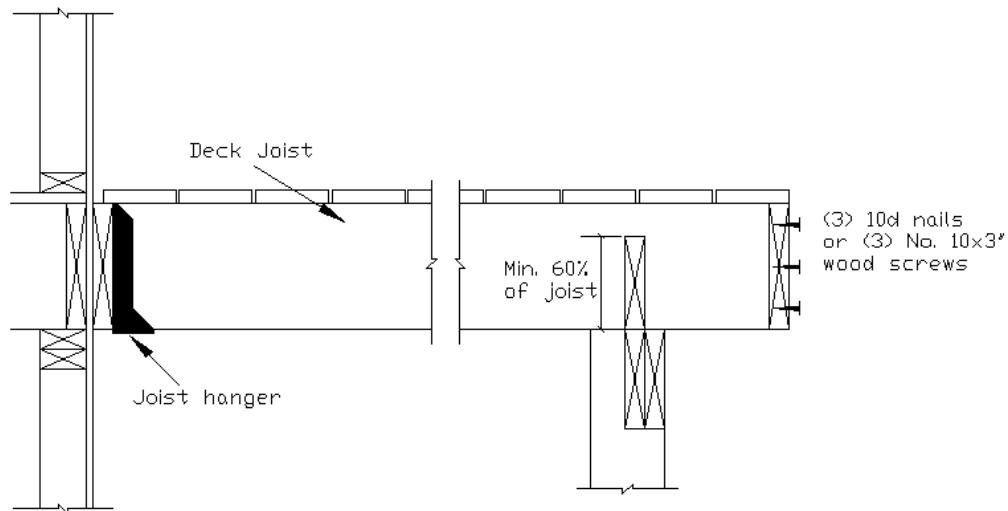

Figure 8

GUARD REQUIREMENTS

Porches, balconies, ramps or raised floor surfaces located more than 30" above the floor or grade, within 36" horizontally to the edge of the open side, shall have guards not less than 36" in height. [R312.1.1/R312.1.2] Open sides of stairs with a total rise of more than 30" shall not have guards less than 34" measured vertically from the tread nosing. [R312.1.2 exception 1]

Required guards on open sides of stairways, raised floor areas, balconies and porches shall have intermediate rails or ornamental closures which do not allow the passage of a sphere 4" or more in diameter. [R312.1.3] Exceptions:

1. The triangular openings formed by the riser, tread and bottom rail at the open side of the stairway are permitted to be of such size that a 6" sphere cannot pass through.
2. Openings for required guards on the sides of stair treads shall not allow the passage of a sphere 4-3/8" in diameter.

The maximum riser height shall be 8-1/4" measured vertically between leading edges of adjacent treads. The minimum tread depth shall be 9" measured horizontally from beginning to end of tread. [PA UCC] Handrails may not be less than 34" nor greater than 38" above tread nosing and must be continuous throughout the run of stairs.

GUARD POST INSTALLATION

Consideration must be taken to the installation techniques of guard posts. Guards and handrails shall be able to resist a live load of 200 psf as a single concentrated load applied in any direction at any point along the top. [R301.5] The International Code Council Evaluation Service Acceptance Criteria 273 for Handrails and Guards (AC273) places reasonable limits on tested assemblies. The maximum permissible deflection in AC273 for 36"-high guards is 3". Due to the large leverage arm of a guard post, and in order to achieve less than a 3-inch deflection at the top of a 36" rail, the post attachment at the deck must be capable of resisting a safety factor of 2.5 (or 500 lbs)! Virginia Tech's *"Design and Testing of Residential Deck*

Guard Rail Connections” guide prescribes post connection details found to have met compliance of the 2018 International Residential Code (see Figure 13).

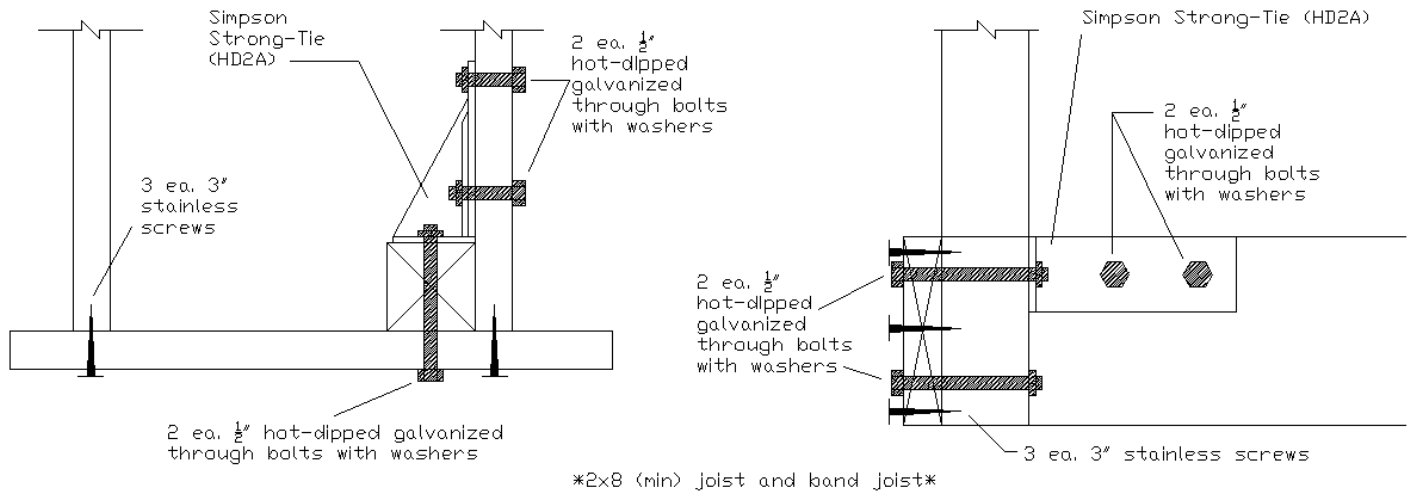

Figure 9

Note that to achieve code-compliance guard posts are not notched.

STAIR HANDRAIL REQUIREMENTS

Handrails shall be provided on at least one side of each continuous run of treads or flight with four or more risers. Handrails shall be located between 34” and 38” measured vertically from the sloped plane adjoining tread nosing. It shall be continuous for the full length of the flight. Handrails shall terminate back to post/wall.

Handrail shall comply with one of the following options:

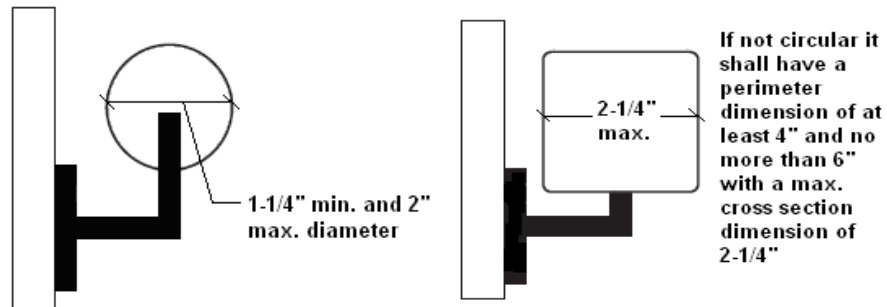

Graspable finger recess area required on both sides

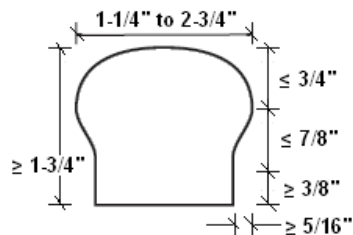

Figure 10

GLAZING IN HAZARADOUS LOCATIONS

Glazing (or glass) in the following hazardous locations shall be tempered: [R308.4]

- In guards and railings, including nonstructural in-fill panels and structural baluster panels. [R308.4.4]
- Adjacent to stairs, landings, and ramps. Glazing where the exposed bottom edge is less than 36-inches above the plane of the adjacent walking surface of stairs, landings, or ramps. [R308.4.6]
 - Exception: A minimum 1-1/2" cross-sectional rail is installed between 34-38 inches above the walking surface. Such rail shall be capable of withstanding 50 plf without contacting the glass. Any glazing a minimum of 36-inches horizontally from the stairway, ramp or landing does not have to be tempered.
- Glazing less than 36-inches above the bottom landing and within 60-inch horizontal arc less than 180 degrees from the bottom tread nosing. [R308.4.7]
 - Exception: Where glazing is protected by a guard, complying with Section R312, and the plane of the glass is more than 19-inches from the guard.

DECKING REQUIREMENTS

Decking material shall be 2"x6" or 5/4" lumber or other approved composite matter. Any synthetic or composite material shall be approved by the building official, only after an ICC Evaluation Report of the particular product. The reports may be found at http://www.icc-es.org/Evaluation_Reports/index.shtml by searching the manufacturer or product name. Decking shall not have a span that would compromise a 50 lb. per square foot load capacity.

APPLICATION AND PROCESS FOR PERMIT

Any owner or authorized agent, who intends to construct a deck, or any other work regulated by the International Residential Code, shall first make application to the building official and obtain the required permit.

A total square footage of the proposed deck and the contractor's name (if any), address, phone number and email address will be required.

Submittals at the time of application shall include a framing/footer plan and a site plan.

The framing plan shall include placement of footers, spans of joists, and size/span of girder beams. Step, railing and attachment details shall also be incorporated into the plans.

EXAMPLE ONLY

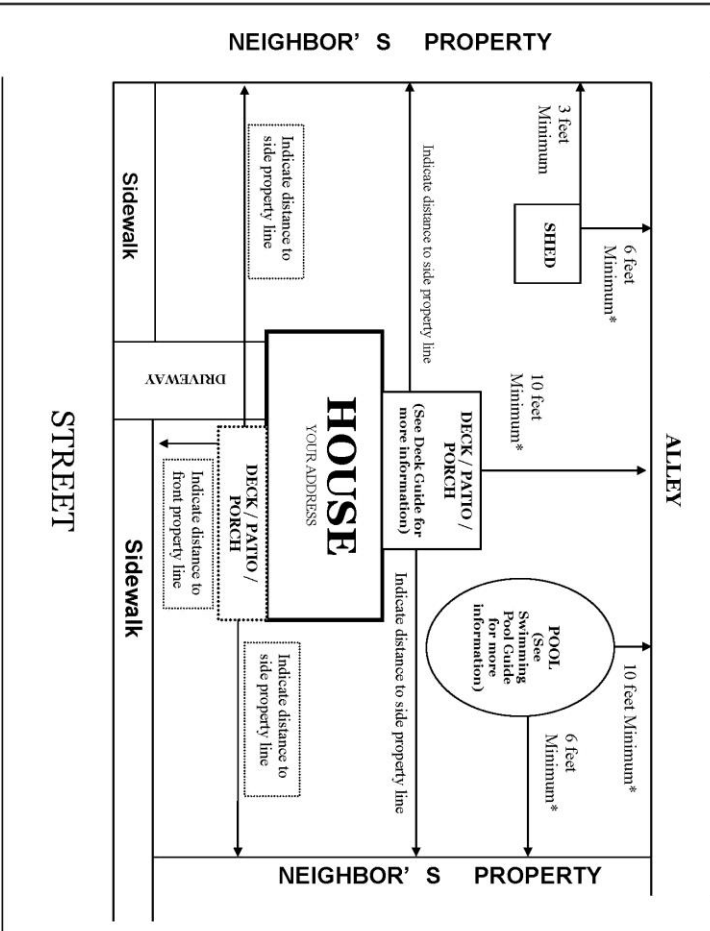

SITE PLAN REQUIREMENTS

- > PLAN MUST SHOW ALL EXISTING STRUCTURES AND THEIR DIMENSIONS (i.e. shed, deck, pool, garage, fence, etc.)
 - > PLAN MUST SHOW ALL PROPERTY LINES AND WHAT SURROUNDS PROPERTY (i.e. neighbors, streets, alleys).
 - > PLAN MUST INCLUDE ALL RIGHT OF WAYS OR EASEMENTS ENCLINBERING YOUR LOT.
 - > FOR FENCE INSTALLATIONS: MUST SHOW LOCATION OF PROPOSED FENCE AND INDICATE THE DISTANCE TO ALL PROPERTY LINES. FENCE MUST BE TWELVE (12) INCHES WITHIN THE OWNER'S PROPERTY LINE AND MAY NOT CONSTITUTE A VISION OBSTRUCTION WITHIN ANY CLEAR SITE TRIANGLE. TO PLACE FENCE ON PROPERTY LINE, SEE ORDINANCE 2559.
- * Minimum setback distances vary depending on the zoning district in which you reside. Any questions, please contact the Zoning Officer, at 610-437-5524 Ext. 1155.

REMEMBER you MUST call PA One Call (811) before ANY excavation begins!