



## **RE Industrial Electronic Actuator General Specifications**

All industrial electric/electronic actuators used for valve applications and air damper control shall incorporate adjustable current limiting as a means of protecting the actuator from over-torque situations. Actuators shall be available from 150 in-lbs to 10,200 in-lbs with these features.

### **Voltage Offering**

All actuators must be capable of accepting 24 VAC or VDC power and 120 or 220 VAC with the addition of a transformer.

### **Duty Cycle**

All actuators shall be rated for 100% duty cycle regardless of application.

### **Motor Protection**

All actuators shall have adjustable current limiting accurate to 1%. Thermal overloads or torque switches shall not be acceptable. The current limiting feature must activate a light upon exceeding the current limit set to allow for easy field diagnostics. The actuator must also have a separate light that stays latched (ON) until power is reset to provide diagnostics for intermittent over-torque situations. An optional solid-state relay (electrically isolated) rated for a minimum of 130 mA from 9 to 130 VAC or VDC shall be available as an option for critical applications where remote indication of the exceeded current limit is required.

### **Speed Control**

All actuators shall have field adjustable speed control as a standard feature.

### **Operating Temperature - Ambient**

Actuators shall be designed for temperatures ranging from -40°F to 150°F (-40°C to 65°C). For temperatures below 32°F (0°C), outdoor applications, high humidity or wet locations the actuators shall be supplied with an electric heater and thermostat.

### **Signal Range/Acceptance**

For On/Off (two-position) or tri-state control, the actuator shall be capable of accepting a wide signal input range of 9 to 130 VAC or VDC without the need for special add on isolation modules.

### **Signal and Power Isolation**

All actuators shall have optically isolated signal inputs so that power and signal do not have to come from the same source to control the actuator. Signal inputs shall not be polarity sensitive.

### **Braking**

All actuators shall have a solid state braking system, which works with or without power, (rated to 1-1/4 times the torque rating of the actuator). Electro-Mechanical brakes or clutches shall not be acceptable.

### **Manual Override**

All units shall be equipped with a manual override which will allow the actuator to be rotated in the clockwise or counter-clockwise direction. Optional solid cast aluminum override handwheels shall be available. Spoked handwheels shall not be acceptable due to safety issues.

### **Enclosure**

The actuator housing shall be a high strength aluminum casting with an exterior grade polyurethane enamel coating for excellent wear, corrosion, impact and UV resistance. All actuators shall be NEMA 4/4X type minimum. All cover fasteners shall be stainless steel. All actuators shall have a position indicator with the angle of rotation clearly marked. All actuators used in outdoor applications shall have white covers to lessen the solar heat load.



### **Mounting**

All actuators shall have interchangeable female output drive shafts to allow for direct mounting and easy mounting for a wide variety of applications.

### **Conduit Entry**

All units shall have two conduit entries. One shall be used for signal and one for power.

### **Gear Train**

All gearing shall be high strength and heat-treated with permanent lubrication. All cluster gears shall be single piece design. Two gears pressed together to form a single cluster shall not be acceptable.

### **Actuators with Modulating Control**

All modulating actuators shall have control circuitry capable of a minimum of 180 points of discrete control in 90 degrees of movement. All internal feedback potentiometers shall be direct mounted to the output shaft. Gear driven potentiometers shall not be acceptable.

### **Input Signals**

The actuator shall be capable of accepting 4-20 mA with 250 Ohms impedance, 0-10 VDC or 2-10 VDC signals. Input signal isolation shall be provided to isolate the input signal from the actuator power so that the signal and power can come from different sources, without the need for exterior isolation modules. Modulating circuitry shall come standard with 4-20 mA and 0-10 VDC feedback circuits and not require additional modules.

### **Limit Switches**

All limit switches shall be independently activated by adjustable cams, one for each direction. An individual light must be provided for each direction of rotation. A separate limit switch and cam shall be provided for customer use rated for 125/250 VAC 10 Amp, 1/3 H.P.

### **Agency Certification**

Entire actuator must be UL508 Listed or certified to CSA C22.2 No. 14-M91. Actuators that only have their motors or individual components recognized are not acceptable.



## How to Select the RE Industrial Actuator Part Number

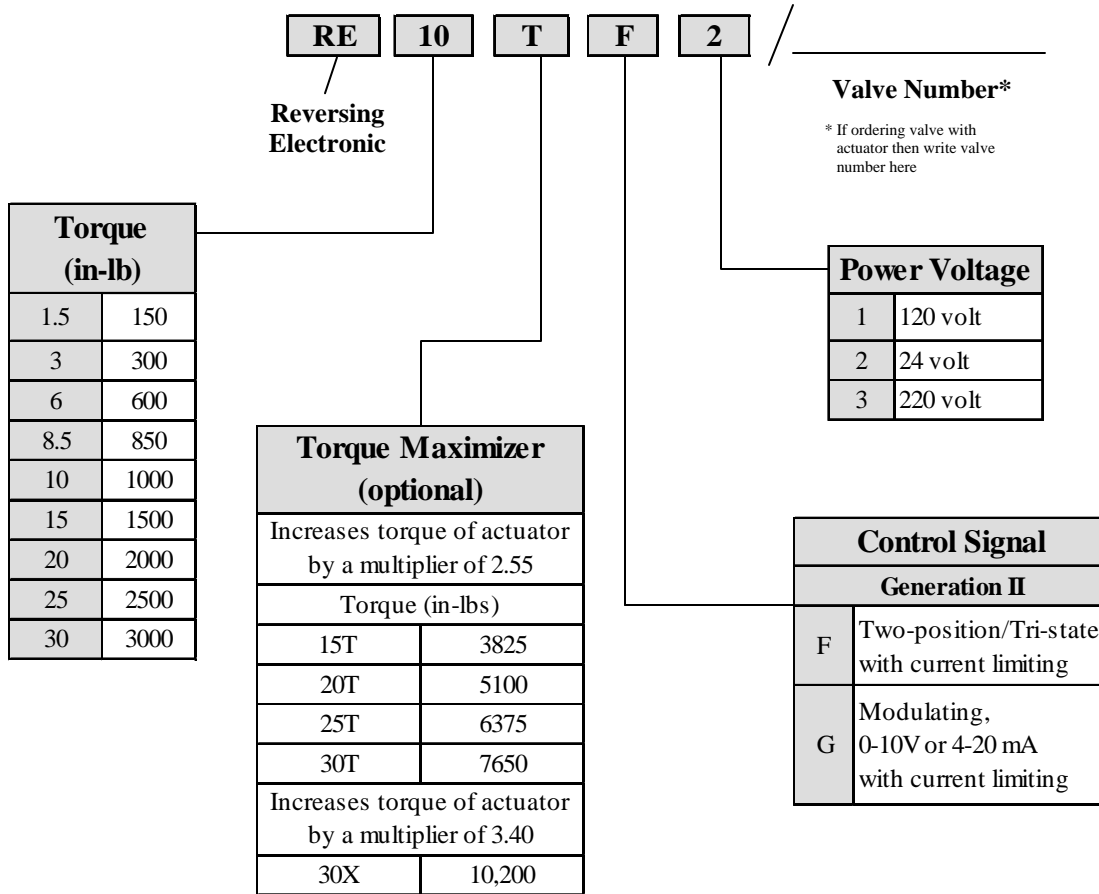

*Note:*

- H/S at end of part number indicates heater and stat (use for very moist or outdoor applications).

Example: Torque                      Part No.  
 1000 in-lb ..... RE10  
 5100 in-lb ..... RE20T





## RE Series Industrial Actuators Features and Benefits

Features	Benefits
Solid state industrial 1/4 turn actuators with current limiting	Actuator stops and holds position when current setpoint is exceeded. Can continue to operate if driven in the opposite direction.
Field adjustable speed setting standard	Can slow speed of actuator by a factor of 2 (i.e. 90 degrees of rotation can be slowed from 35 seconds to 70 seconds).
Optically isolated signal inputs	Power and signal do not have to come from the same source (no more ground loop problems).
Inputs are not polarity sensitive for on/off or tri-state control	Positive and negative are interchangeable. Easier wiring, application and troubleshooting.
LED diagnostic indicators 2 end of travel and 2 torque related	Simple troubleshooting.
Standard 4 Amp knife blade standard automotive fuse	Commonly available.
True 100 % Duty Cycle	Requires no rest period between cycles.
Solid state braking system works with or without power (rated to 1-1/4 X torque)	Prevents valve or damper from drifting when power is absent. Not moisture sensitive. Elect./Mechanical brakes tend to be extremely sensitive to moisture and can lock up.
Heavy duty terminals for field interface	Fast, reliable field hook-up.
Designed with higher voltage electronic components	Reduces typical static and handling problems.
Automatic adjustment for damper or valve seal wear	Current limiting feature ensures positive close-off. Prevents jamming the damper or driving the valve too far into seat.
Two-position control: Wide input signal voltage range (9 - 130 VAC or VDC)	Allows for long distance signal runs. Flexibility also allows for early commissioning.
Entire Actuator is UL508 and cUL C22.2 No. 14-M91 listed.	Meets rigid engineering specifications



**RE Series Industrial NEMA 4/4X Type Actuators  
Torque: 150 In-Lb to 10,200 In-Lb**

<b>Technical Data</b>	<b>RE1.5F - RE8.5F</b>	<b>RE1.5G - RE8.5G</b>	<b>RE10F-RE30XF</b>	<b>RE10G - RE30XG</b>
Power supply	12 VDC, 24 VAC or VDC, 120 VAC, 50/60 Hz, other options available			
Power Consumption**	30 VA (Class 2 power source required)		56 VA (Class 2 power source required)	
Electrical connection	Dual conduit entry (1/2")		Dual conduit entry (3/4")	
Overload protection	Electronic - Solid State			
Control signal	Two-pos./tri-state* (floating)	0-10 VDC, 4-20 mA std., field adj.	Two-pos./tri-state* (floating)	0-10 VDC, 4-20 mA std., field adj.
Input impedance	250 Ohms for 4 - 20 mA			
Operating range	0 to 10 VDC, 2 to 10 VDC, 4 to 20 mA, custom signal ranges available			
Feedback output	0 to 10 VDC standard, 4 to 20 mA optional			
Angle of rotation	Typically 90°, Option: adjustable 65° to 320°			
Minimum torque	Depends on model - see Table			
Direction of rotation	Standard: increase signal = CCW (jumper selectable)			
Position indication	Visual mechanical position indicator			
Gear train	Heat treated metal gears, permanently lubricated			
Brakes	Solid State braking system (power not required)			
Manual override	De-clutching shaft with flats, optional override handwheel			
Duty cycle	100%			
Auxiliary switches - Switch - Range usage - Factory setting - Ratings (Resistive)	1 standard, up to 3 optional Form C; SPDT 0 - 320° None - 125/250 VAC: 10 Amps, 1/3 hp - 12 VDC: 5.0 Amps; 30 VDC: 2.0 Amps Customs Available - Call Dodge Engineering			
Switch connections:	Male quick connect type tabs			
Control signal adjustment: (for modulating units) - Offset (startpoint) - Factory setting - Span	-	0 - 3 VDC 0 - 10 VDC or 4-20 mA Adjustable	-	0 - 3 VDC 0 - 10 VDC or 4-20 mA Adjustable
Running time (90°)(nominal)	Adjustable - See RE Series Industrial Actuators Table			
Humidity	95% RH, noncondensing			
Operating temperature†	-40°F to 150°F (-40°C to 65°C)			
Agency Compliance	UL 508 Listed, File E253925; cUL Certified to Canadian standard C22.2 No. 14-M91***			
Housing type	Type 4/4X according to UL, cUL			
Housing material	Cast aluminum, with exterior grade polyurethane enamel coating.			
Options: - Heater & thermostat † - Override handwheel - Alarm relay	For outdoor and moist environments Non-spoked for safety Output - rating 130 mA max., 9 - 130 VAC/DC			
Servicing	Maintenance free			
Weight	17 lbs		25 lbs ††	

*Notes:*

\* Input signal range from 9 - 130 VAC or VDC. Use normal switched signals only (i.e. relay contacts or switches).

**Do Not Use Triacs.**

\*\* Does not include line loss. Add 16 VA if heater and stat (H/S) is used.



RE Series Industrial Actuators					
Actuator Model No.	Output Torque		Speed* sec./90°	Speed** sec./270°	Speed** sec./360°
	in-lb	N-m			
RE1.5	150	17	10 - 25	—	—
RE3†	300	34	10 - 25	—	—
RE6	600	68	10 - 25	—	—
RE8.5	850	96	10 - 25	—	—
RE10†	1000	114	35 - 70	—	—
RE15	1500	170	35 - 70	—	—
RE20	2000	227	35 - 70	—	—
RE25	2500	284	35 - 70	—	—
RE30	3000	340	35 - 70	—	—
RE15T**	3825	434	—	105 - 210	—
RE20T**	5100	579	—	105 - 210	—
RE25T**	6375	724	—	105 - 210	—
RE30T**	7650	869	—	105 - 210	—
RE30X**	10200	1158	—	—	140-280

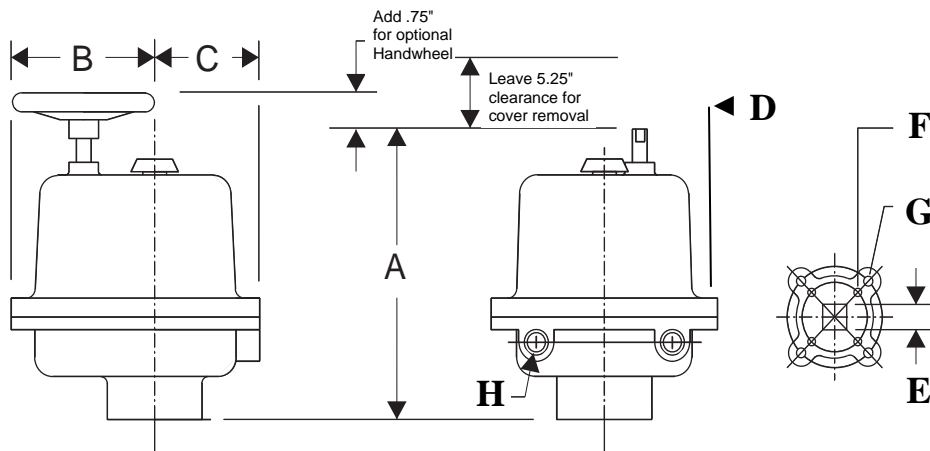

RE Series Industrial Actuators Dimensions								
Actuator Model No.	Dimensions (Inches)							
	A	B	C	D	E	F	G	H
RE1.5 - RE8.5	9.93	5.15	3.48	7.42	0.75 sq. 0.63 deep	N/A	5/16-18UNC-2B 0.625 deep BC: 3.25	1/2" NPT
RE10 - RE30	11.65	6.07	4.40	9.75	1.00 sq. 2.00 deep	3/8-16UNC-2B 1.12 deep BC: 4.00	7/16-14UNC-2B 1.50 deep BC: 4.965	3/4" NPT

**Notes:**

- \* Speed is adjustable and varies slightly with load.
- \*\* When using a Torque Maximizer, see page AC-11 in our DEI catalog for further details and requirements.
- † Faster speeds available. Please call DEI.



### RE Current Limited Board Example Wiring For 2-wire On/Off control applications

Example uses same 24VAC for power and signal (see note 5)

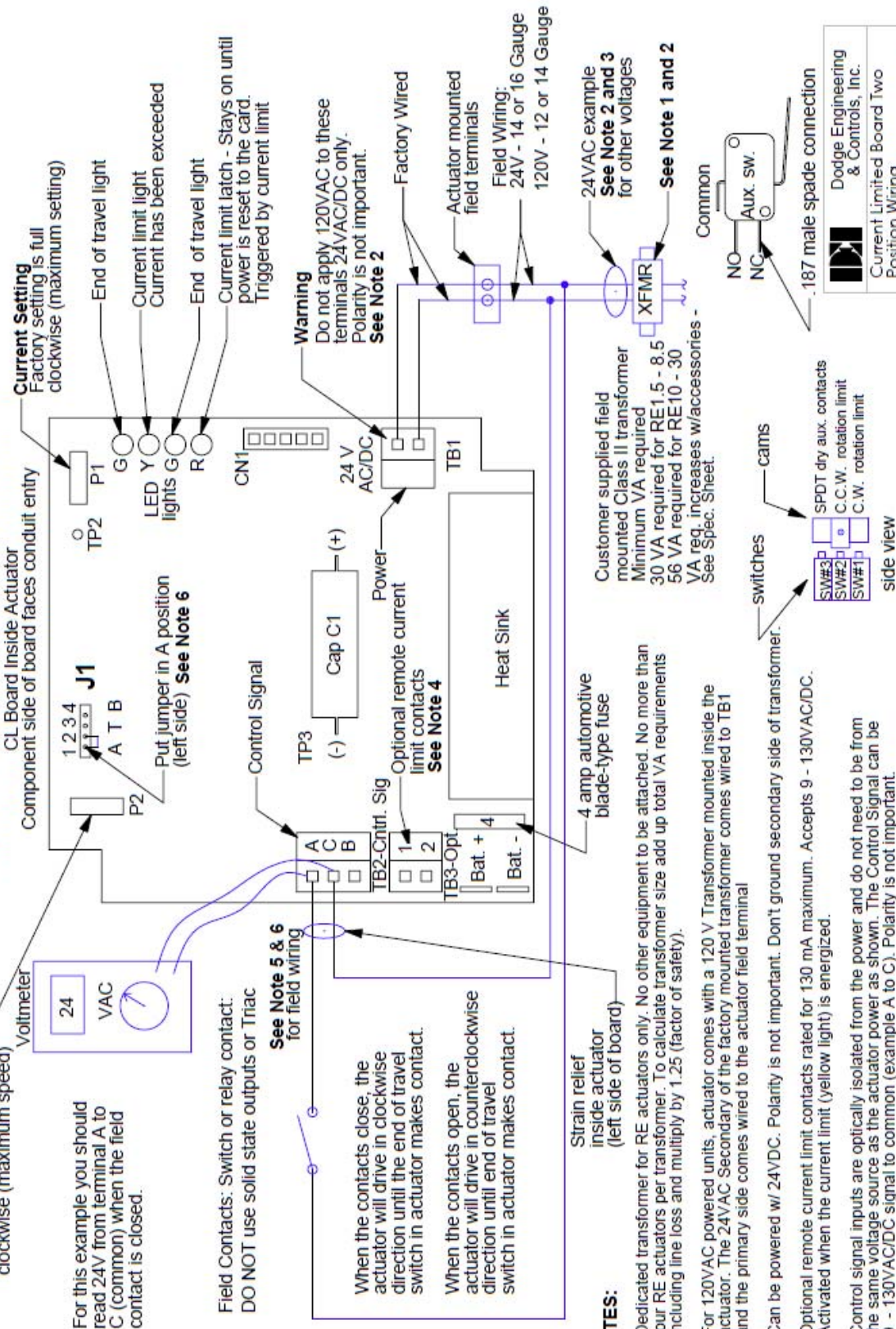

#### Speed Setting

Factory setting is full clockwise (maximum speed)

For this example you should read 24V from terminal A to C (common) when the field contact is closed.

Field Contacts: Switch or relay contact. DO NOT use solid state outputs or Triac

When the contacts close, the actuator will drive in clockwise direction until the end of travel switch in actuator makes contact.

When the contacts open, the actuator will drive in counterclockwise direction until end of travel switch in actuator makes contact.

Strain relief inside actuator (left side of board)

4 amp automotive blade-type fuse

Customer supplied field mounted Class II transformer

Minimum VA required 30 VA required for RE1.5 - 8.5 56 VA required for RE10 - 30 VA req. increases w/accessories - See Spec. Sheet.

Common NO NC

.187 male spade connection

switches

cams

SPDT dry aux. contacts

C.C.W. rotation limit

C.W. rotation limit

side view

Warning Do not apply 120VAC to these terminals 24VAC/DC only. Polarity is not important. See Note 2

Factory Wired

Actuator mounted field terminals

Field Wiring: 24V - 14 or 16 Gauge 120V - 12 or 14 Gauge

24VAC example See Note 2 and 3 for other voltages

See Note 1 and 2

Warning Do not apply 120VAC to these terminals 24VAC/DC only. Polarity is not important. See Note 2

Warning Do not apply 120VAC to these terminals 24VAC/DC only. Polarity is not important. See Note 2

Warning Do not apply 120VAC to these terminals 24VAC/DC only. Polarity is not important. See Note 2

Warning Do not apply 120VAC to these terminals 24VAC/DC only. Polarity is not important. See Note 2

Warning Do not apply 120VAC to these terminals 24VAC/DC only. Polarity is not important. See Note 2

Warning Do not apply 120VAC to these terminals 24VAC/DC only. Polarity is not important. See Note 2

Warning Do not apply 120VAC to these terminals 24VAC/DC only. Polarity is not important. See Note 2

Warning Do not apply 120VAC to these terminals 24VAC/DC only. Polarity is not important. See Note 2

Warning Do not apply 120VAC to these terminals 24VAC/DC only. Polarity is not important. See Note 2

Warning Do not apply 120VAC to these terminals 24VAC/DC only. Polarity is not important. See Note 2

Warning Do not apply 120VAC to these terminals 24VAC/DC only. Polarity is not important. See Note 2

Warning Do not apply 120VAC to these terminals 24VAC/DC only. Polarity is not important. See Note 2

Warning Do not apply 120VAC to these terminals 24VAC/DC only. Polarity is not important. See Note 2

Warning Do not apply 120VAC to these terminals 24VAC/DC only. Polarity is not important. See Note 2

Warning Do not apply 120VAC to these terminals 24VAC/DC only. Polarity is not important. See Note 2

Warning Do not apply 120VAC to these terminals 24VAC/DC only. Polarity is not important. See Note 2

Warning Do not apply 120VAC to these terminals 24VAC/DC only. Polarity is not important. See Note 2

Warning Do not apply 120VAC to these terminals 24VAC/DC only. Polarity is not important. See Note 2

#### NOTES:

1. Dedicated transformer for RE actuators only. No other equipment to be attached. No more than four RE actuators per transformer. To calculate transformer size add up total VA requirements including line loss and multiply by 1.25 (factor of safety).
2. For 120VAC powered units, actuator comes with a 120 V Transformer mounted inside the actuator. The 24VAC Secondary of the factory mounted transformer comes wired to TB1 and the primary side comes wired to the actuator field terminal
3. Can be powered w/ 24VDC. Polarity is not important. Don't ground secondary side of transformer.
4. Optional remote current limit contacts rated for 130 mA maximum. Accepts 9 - 130VAC/DC. Activated when the current limit (yellow light) is energized.
5. Control signal inputs are optically isolated from the power and do not need to be from the same voltage source as the actuator power as shown. The Control Signal can be 9 - 130VAC/DC signal to common (example A to C). Polarity is not important.
6. To reverse action of actuator, wire field contacts to B and C terminals and place jumper at J1 to the B position (right side).
7. Bottom two switches factory set for end of travel rotation. Do not adjust unless rotation angle needs to be changed. Switch #3 and above are for customer use.

Dodge Engineering & Controls, Inc.	
Current Limited Board Two Position Wiring	
REV. E	DATE 1526
SHEET 1 OF 1	APPROVED

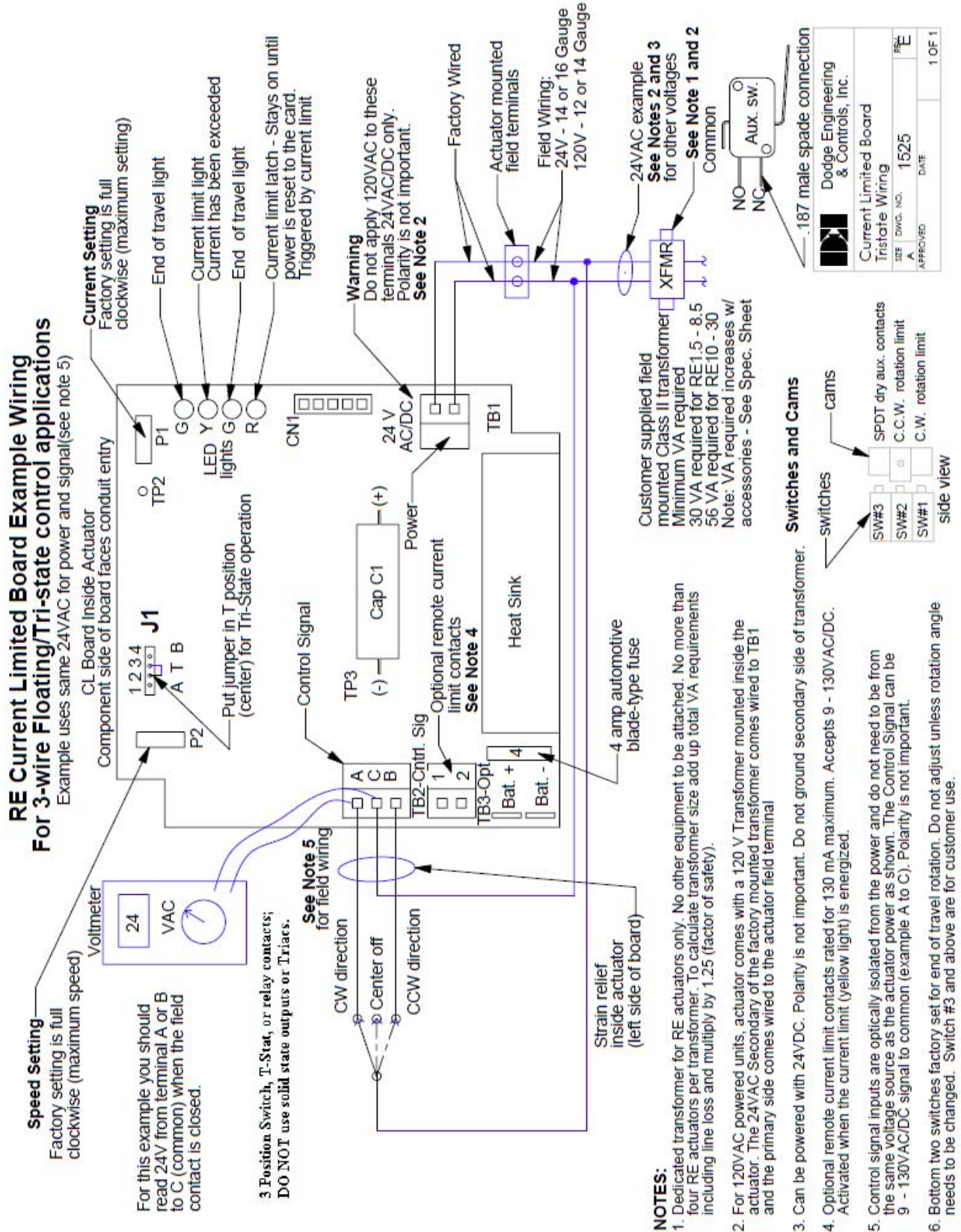

Dodge Engineering & Controls, Inc.	
Current Limited Board	
REV	DWG. NO. 1525
DATE	DATE
APPROVED	DATE
1 OF 1	





### RE Current Limited Board Example Wiring When Used With A Modulating Control Board

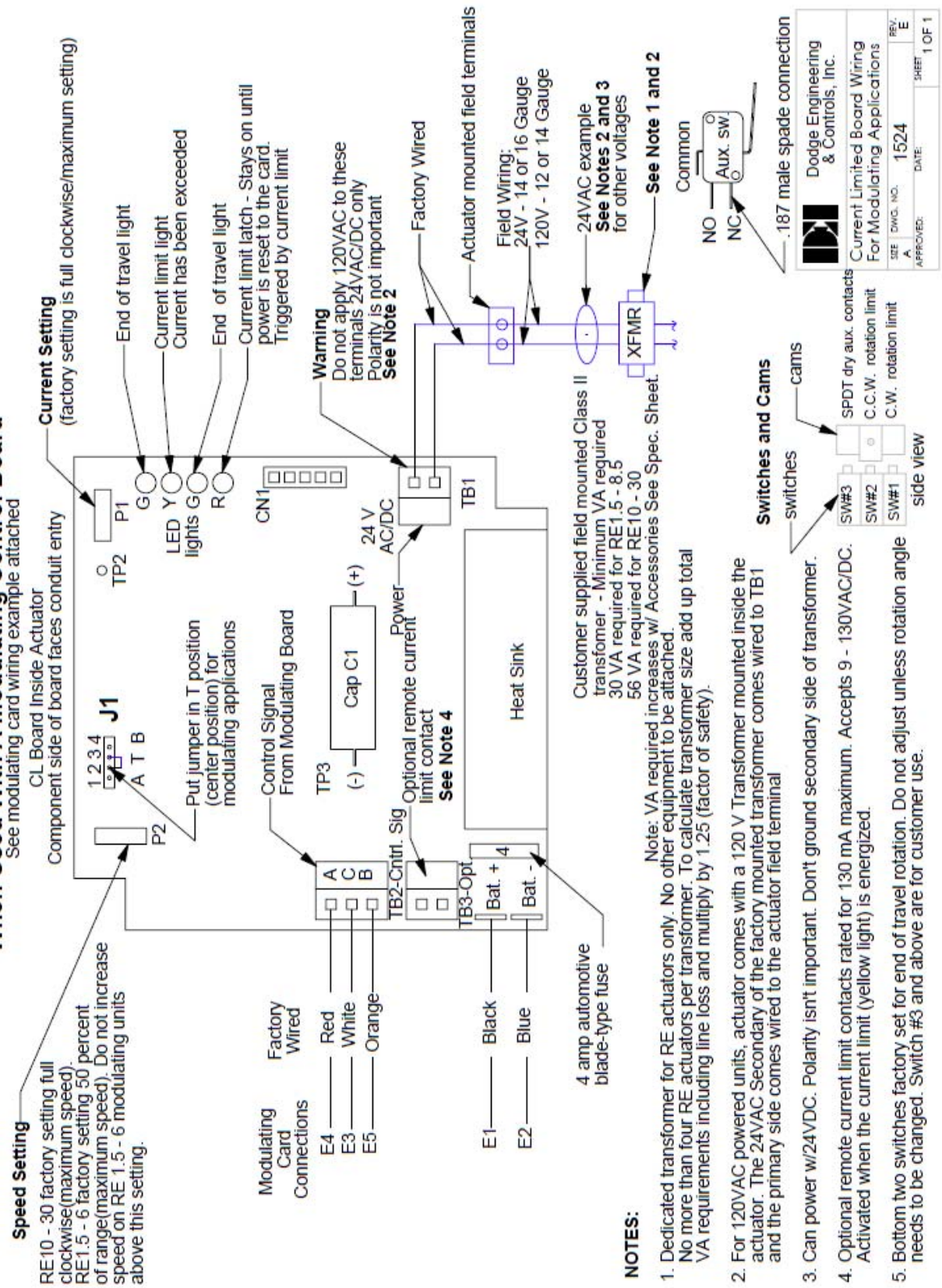

Dodge Engineering & Controls, Inc.  
Current Limited Board Wiring  
For Modulating Applications

REV. E	DATE:	SHEET 1 OF 1
APPROVED:	1524	
SEE DWG. NO.		

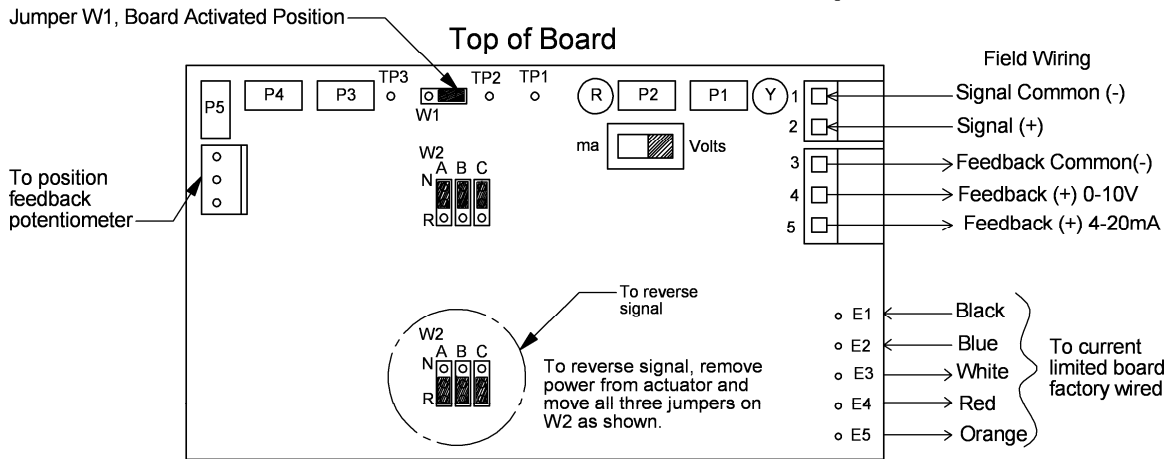
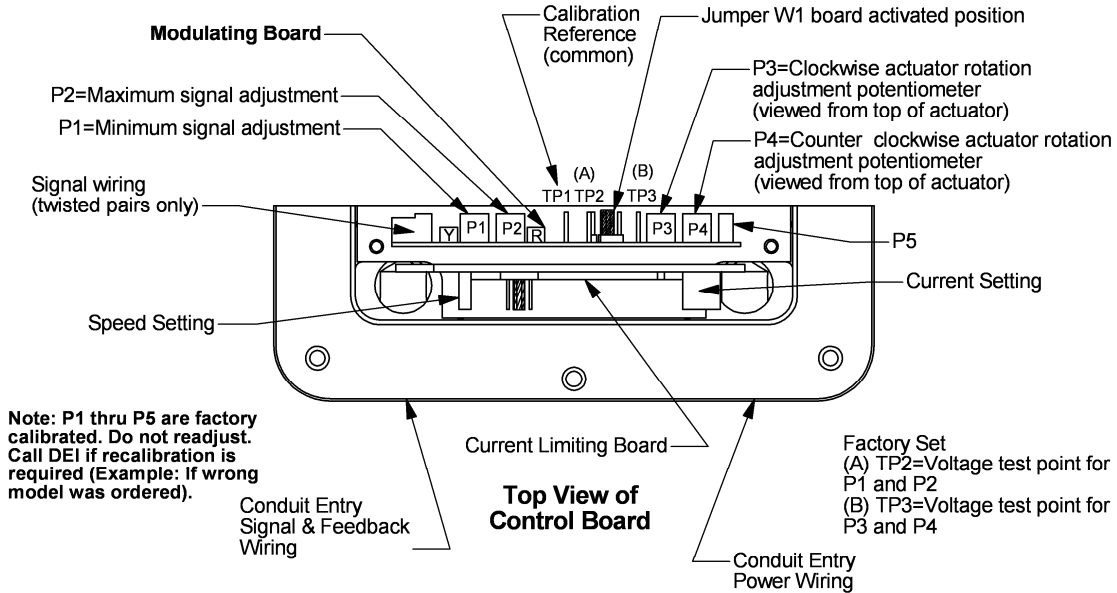

**Modulating Board Component Side**

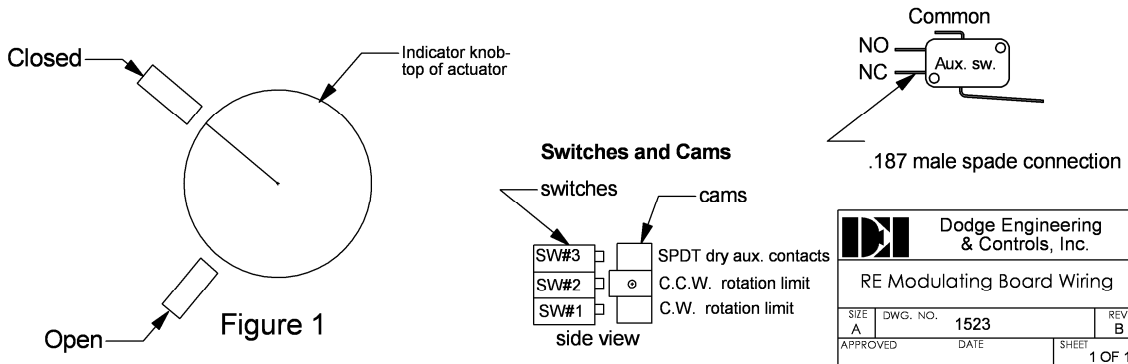



## Torque Maximizer

The Torque Maximizer permits DEI's actuators to operate at required torques up to 10,200 in-lbs. It also allows the actuator to be mounted in applications with space or location limitations.

**Operation:** The Torque Maximizer provides added gear reduction between the actuator and the valve or damper, thereby increasing the torque of the actuator. This product is 85% efficient in transferring the torque from the input to output drive shaft. This unit bolts directly onto the base of the DEI actuator, then the combined actuator/gear operator unit is mounted to the valve, damper or other application.\*

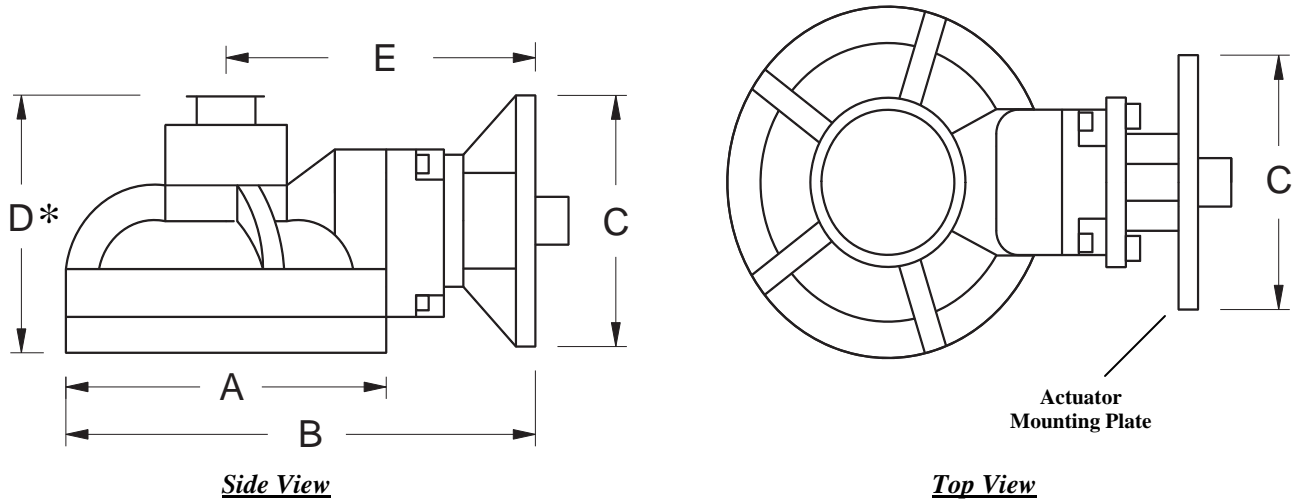

Model	Weight lbs (kg)	Dimensions in (mm)				
		A	B	C	D	E
T	38	7.25	10.63	5.25	4.63	7.00
	(17)	(184)	(270)	(133)	(118)	(178)
X	78	11.25	15.50	5.25	6.63	9.88
	(35)	(286)	(394)	(133)	(169)	(251)

**Rotation Time:** The Torque Maximizer gear unit model T (3:1 gear ratio) requires 270° of rotation to the input shaft to rotate the output shaft 90°. Model X (4:1 gear ratio) requires 360° of rotation for 90° of rotation at the output shaft. Therefore, the time it takes to rotate the output shaft of the Model T 90° is 3 times the values listed on the “RE” product specification sheet for 90° rotation. The Model X requires 4 times the values listed for the respective actuator. Please note that many applications do not require the output shaft to turn a full 90°, thereby reducing the time.

Both models are furnished with a semi-gloss black, baked epoxy, powder coat paint finish.

Torque Maximizer Input/Output						
Model	Input Torque		Output Torque		Gear Ratio	Mech. Advantage
	in-lb	N-m	in-lb	N-m		
RE15T	1,500	169	3,825	432	3:1	2.55
RE20T	2,000	225	5,100	576	3:1	2.55
RE25T	2,500	282	6,375	720	3:1	2.55
RE30T	3,000	338	7,650	864	3:1	2.55
RE30X	3,000	338	10,200	1,152	4:1	3.40

**Notes:**

- Pictures not drawn to scale.
- \* For overall assembly dimension to valve, call DEI. Bracket height is not included in dimensions.



## Rack & Pinion Pneumatic Actuators

### FEATURES & BENEFITS



DEI's Rack & Pinion Pneumatic Actuators are designed for high reliability operation. They are permanently lubricated and feature a corrosion resistant hard anodized finish.

- **ISO MOUNTING** conforms to the ISO 5211 mounting standard, which fits more mounting configurations with less hardware variation (on models PN/PS20 through PN/PS1750 only).
- **SUBSTANTIAL PINION BEARINGS** provide protection against side loading which increases cycle life.
- **CORROSION RESISTANT** rugged hard anodized finish (standard) ensures protection from most corrosive environments. Optional baked epoxy finish available for severe environments. Call DEI for more information.
- **NAMUR ACCESSORY MOUNTING PATTERN** allows for more combinations of solenoids, positioners and limit switches with minimal or no mounting hardware.
- **INDIVIDUAL SPRINGS** allow for torque adjustment. Springs can be added or deleted to "fine tune" the torque output. All the springs in each actuator are the same size.
- **ACCESSORIES** are available for a wide variety of control signals, controller, computer and control panel interface.

### TECHNICAL DATA

- **Maximum Working Pressure** 150 PSIG
- **Standard Working Temperature** -20°F to 175°F
- **Air Supply** Double Acting and Spring Return 40-150 PSIG
- **Rotation** 90° Travel - Travel Stops standard
- **Operating Media** Clean, dry air, noncorrosive gas or light hydraulic oil

#### Counter Clockwise

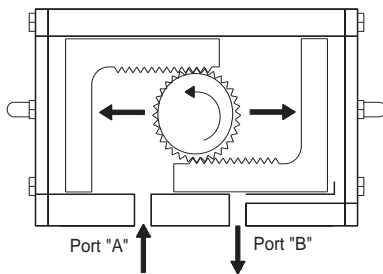

#### Double Acting Operation

##### Counter Clockwise

Air is supplied to Port A which forces the pistons away from each other (toward ends). This rotates the drive pinion counter clockwise which exhausts air out of Port B.

##### Clockwise

Air is supplied to Port B which forces the pistons toward each other (toward center). This rotates the drive pinion clockwise which exhausts air out of Port A.

#### Clockwise

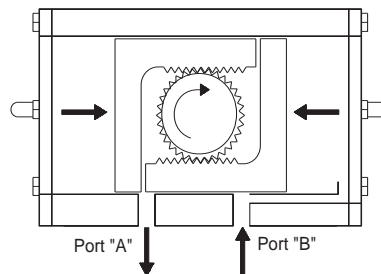

#### Spring Return Operation

##### Counter Clockwise

Air is supplied to Port A which forces the pistons away from each other (toward ends). This rotates the drive pinion counterclockwise which compresses the springs and exhausts the air out of Port B.

##### Fail Clockwise (CCW optional, call DEI)

Air failure (loss of pressure) allows the compressed springs to force the pistons toward each other (toward center). This rotates the drive pinion clockwise and exhausts air out of Port A.

#### Spring-Return Only

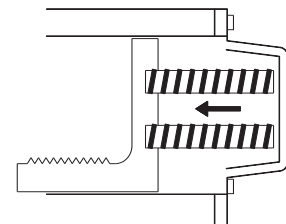



## Rack & Pinion Pneumatic Actuators Dimensional Information

### Double Acting Actuators

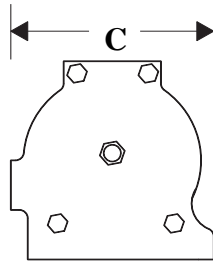
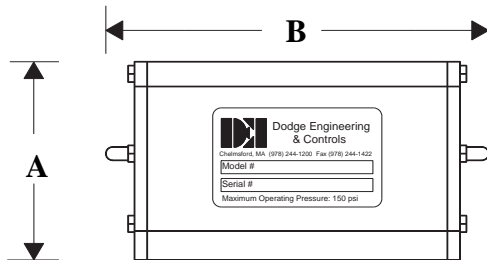

**DEI Rack & Pinion  
Double Acting Pneumatic Actuator**

Double Acting Actuators					
Actuator Model No.	Dimensions (inches)			Cycle Times (secs/90°)	
	A	B	C	CW	CCW
PN20	2.68	6.81	2.58	0.5	0.5
PN40	3.39	7.68	3.25	0.6	0.6
PN80	4.45	8.23	4.33	1	0.6
PN130	4.88	9.60	4.76	1	0.7
PN200	5.28	9.96	5.22	1	0.7
PN300	6.18	11.30	5.98	1.5	1
PN500	6.93	12.56	6.69	2	1.5
PN850	8.27	16.69	7.64	2.5	2
PN1200	9.17	15.67	7.83	4	3
PN1750	10.08	19.84	9.29	5	4

### Spring Return Actuators

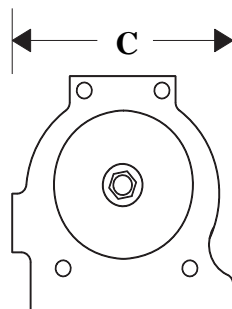
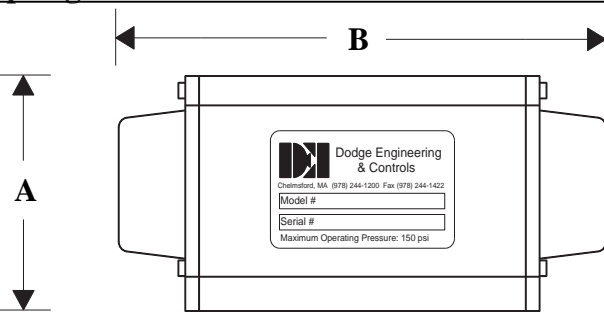

**DEI Rack & Pinion  
Spring Return Pneumatic Actuator**

Spring Return Actuators					
Actuator Model No.	Dimensions (inches)			Cycle Times (secs/90°)	
	A	B	C	CW	CCW
PS20	2.68	8.39	2.58	0.5	0.5
PS40	3.39	7.56	3.25	0.6	0.6
PS80	4.45	8.94	4.33	1	0.6
PS130	4.88	10.39	4.76	1	0.7
PS200	5.28	11.50	5.22	1	0.7
PS300	6.18	13.23	5.98	1.5	1
PS500	6.93	16.26	6.69	2	1.5
PS850	8.27	20.24	7.64	2.5	2
PS1200	9.17	19.80	7.83	4	3
PS1750	10.08	28.15	9.29	5	4



## Rack & Pinion Pneumatic Actuators

### Spring Return Torque (in-lbs)

Actuator Model No.	Spring Torque		Air Supply					
			60 PSI		80 PSI		100 PSI	
	End	Break	End	Break	End	Break	End	Break
PS20	49	84	25	60	61	96	105	140
PS40	82	142	43	103	103	164	165	226
PS80	215	410	109	304	282	477	455	651
PS130	315	573	127	385	357	614	607	864
PS200	420	760	220	560	549	889	879	1219
PS300	880	1605	485	1210	1184	1909	1874	2599
PS500	1325	2300	750	1725	1759	2734	2769	3744
PS850	1815	3050	1719	2345	2429	3664	3709	4944
PS1200	2625	4550	1460	3385	3349	5274	5169	7094
PS1750	3475	6075	2480	5080	5234	7834	7884	10484

**Notes:**

- Torques are actual. Please be sure to include appropriate safety factors and all service conditions variables when sizing.
- Three-way (master-slave) assemblies should use a 35% safety factor. Call factory for assistance.

### Double Acting Torque (in-lbs)

Actuator Model No.	Air Supply				
	40 PSI	60 PSI	80 PSI	100 PSI	120 PSI
PN20	69	109	145	180	229
PN40	103	185	246	308	370
PN80	346	519	693	866	1038
PN130	460	700	930	1180	1390
PN200	650	980	1310	1640	1968
PN300	1390	2090	2790	3480	4270
PN500	2030	3050	4060	5070	6090
PN850	2930	4160	5480	6760	8200
PN1200	3850	6010	7910	9780	11830
PN1750	5480	8555	11310	13960	16960





## Scotch Yoke Design Pneumatic Actuators PN2500, PN3500, PS2500 & PS3500

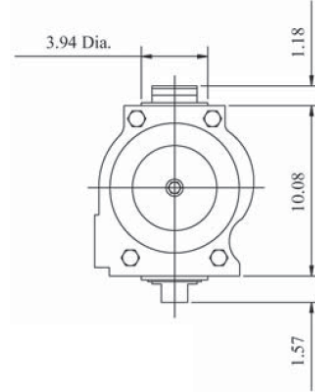
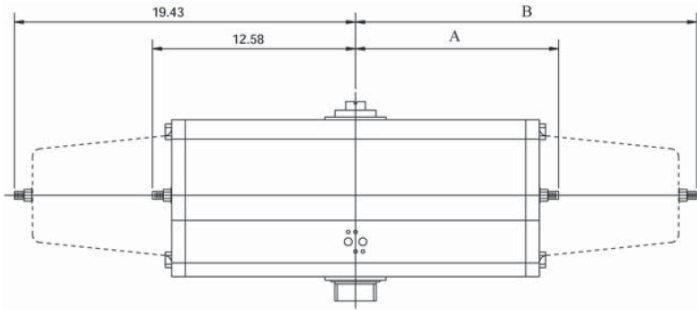

Actuator Model No.	Dimensions (inches)			Cycle Times (secs/90°)		Volume (cu. in./90°)	
	A	B	Base Width	CW	CCW	CW	CCW
<b>Double Acting</b>							
PN2500	7.25	–	9.38	5	5	525	310
PN3500	12.58	–	9.38	9	9	650	585
<b>Spring Return</b>							
PS2500	–	7.25	9.38	5	5	525	310
PS3500	–	19.43	9.38	9	9	1650	585

<b>Double Acting Torque (in-lbs)</b>			
Actuator Model No./PSI	0°	40°	90°
<b>PN2500</b>			
60 psi	13627	7858	9196
80 psi	18734	8276	12456
100 psi	24411	10366	15382
<b>PN3500</b>			
60 psi	26919	12791	18141
80 psi	35864	17054	24160
100 psi	45060	21318	30196

<b>Spring Return Torque (in-lbs)</b>						
Actuator Model No./PSI	Air Break	Run	Air End	Spring Break	Run	Spring End
	0°	60°	90°	90°	30°	0°
<b>PS2500</b>						
60 psi	6890	2852	4039	7224	2974	4241
80 psi	9152	3784	5368	9592	3960	5632
100 psi	11510	4744	6758	12038	4972	7066
<b>PS3500</b>						
60 psi	13780	5702	8078	14449	5948	8483
80 psi	18304	7568	10736	19184	7920	11264
100 psi	22978	9486	13464	24076	11264	14132

$$\text{Air Consumption (scf per 90°)} = \frac{\text{Volume}}{1,728} \times \frac{\text{Supply Pressure} + 14.7}{14.7}$$

**Notes:**

- Accessory mounting holes are not intended for Manual Gear Overrides or Stop Blocks. Cycle times are under no load conditions. Air line size, air capacity and valve torque characteristics affect these cycle times. Faster or slower cycle times can be accomplished using special control components.



# Pneumatic - Pneumatic Positioner: Rotary Type IP5100

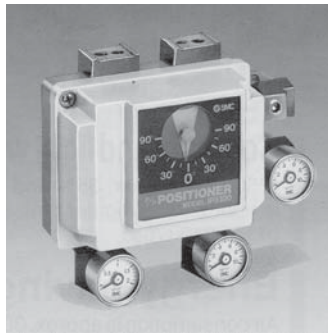

- High performance positioner
- Resistant to hostile environments
- Exceptional shock and vibration performance

### Energy Saving:

- Air consumption is approximately 30% less than existing types

### Complete Optional Specifications:

- Opening indicator
- Built-in equalizing valve (OUT1-OUT2)

### Easy Maintenance:

Maintenance and parts replacement made easy by modular construction

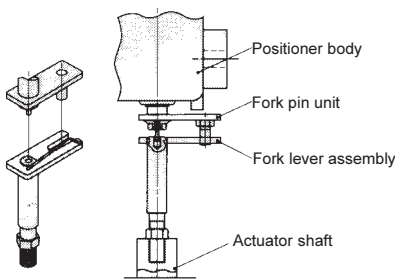

### Standardization of Fork Lever Joint:

- Linkage design tolerates a slight misalignment of shafts

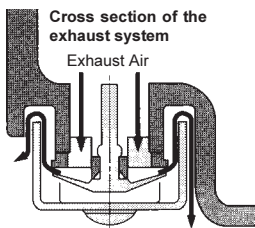

Employs the combination of the check valve and the labyrinth effect.

### Approved by JISF8007IP55:

A centralized exhaust system enhances both dust-proof and waterproof qualities. Epoxy-type coating inside the body prevents corrosion due to moisture.

### Overall Dimensions:

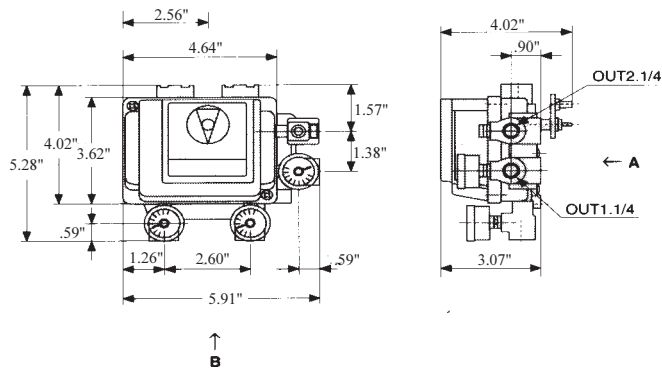





## Pneumatic - Pneumatic Positioner: Rotary Type IP5100

IP5100	
Rotary type cam feedback	
Single or double action	
Supply air pressure	20-101 PSI
Input pressure signal	3-15 PSI
Stroke	60° ~ 100°
Sensitivity	within 0.5% full scale
Linearity	within +/-2% full scale
Hysteresis	within 1% full scale
Repeatability	within +/-0.5% full scale
Air consumption	0.18 CFM* or less (SUP=20 PSI), 0.39 CFM* or less (SUP=58 PSI)**
Output flow	2.83 CFM* or less (SUP=20 PSI), 7.06 CFM* or less (SUP=58 PSI)**
Ambient and air temperature	-4°F - 176°F (standard)
Coefficient of temperature	within 0.1% full scale/°C
Air port	Rc(PT)1/4 (standard)
Main component parts	Aluminum diecast, Stainless steel, Brass, Nitrile rubber
Weight	Approx. 2.65 lbs
Dimensions	4.65" x 3.62" x 3.05" (body)

Notes: \* Standard atmospheric conditions

\*\* Standard air temp: 68°F (20°C); absolute pressure: 14.7 PSI; relative humidity: 65%

### How to Order:

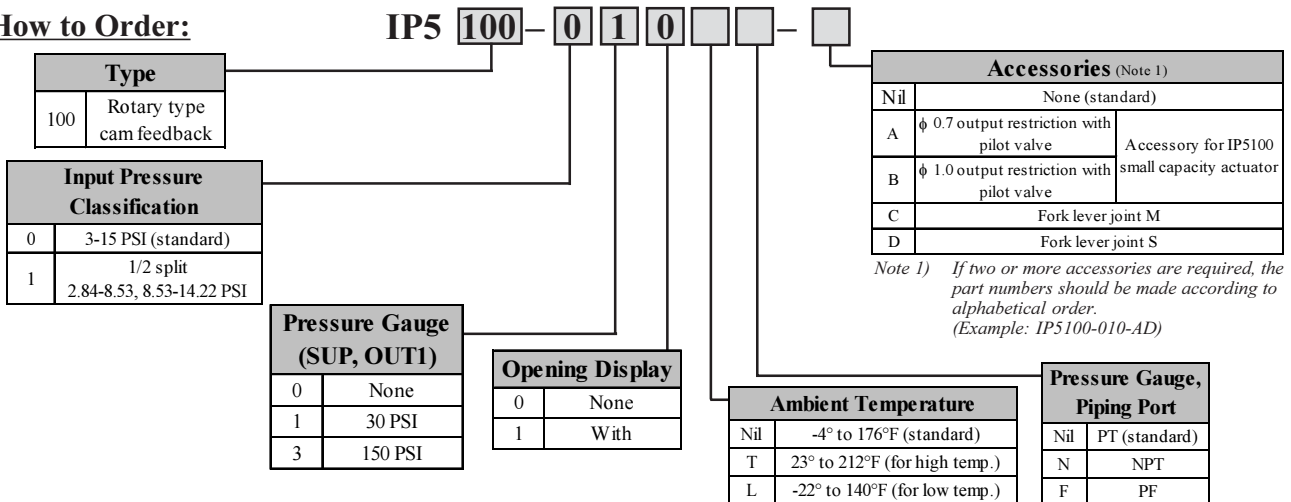



## Pneumatic - Pneumatic Positioner: Rotary Type IP5100

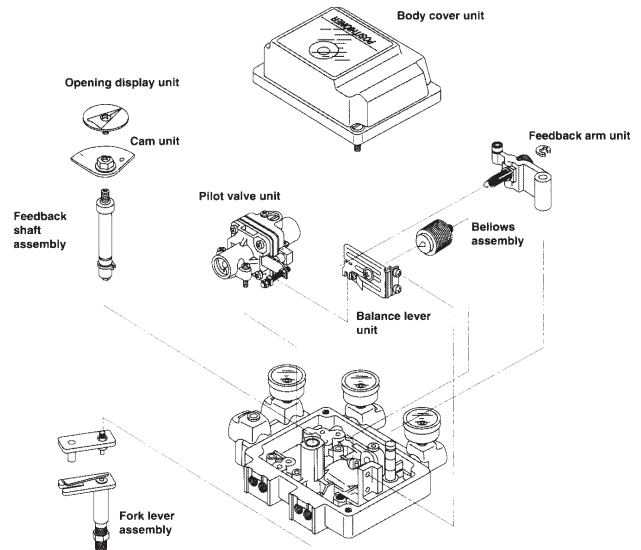
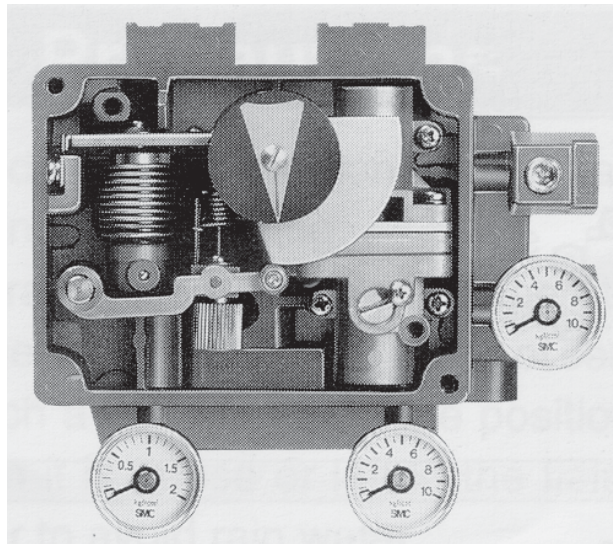

### Single Action

#### Positive Operation

When the input signal is increased, the actuator shaft rotates in a clockwise direction.

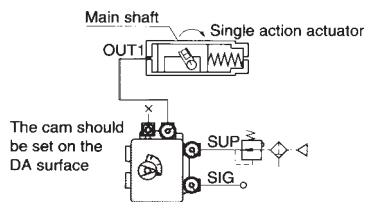

#### Reverse Operation

When the input signal is increased, the actuator shaft rotates in a counterclockwise direction.

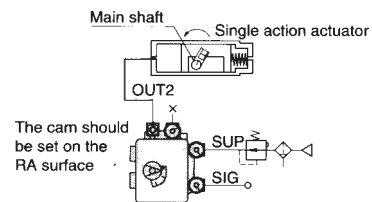

### Double Action

#### Positive Operation

When the input signal is increased, the actuator shaft rotates in a clockwise direction.

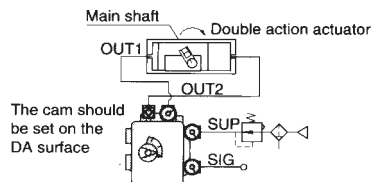

#### Reverse Operation

When the input signal is increased, the actuator shaft rotates in a counterclockwise direction.

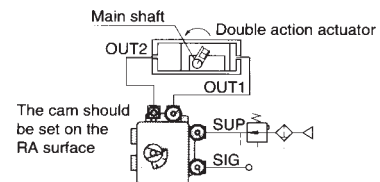



## NAMUR Interface 5 Port Solenoid Valve

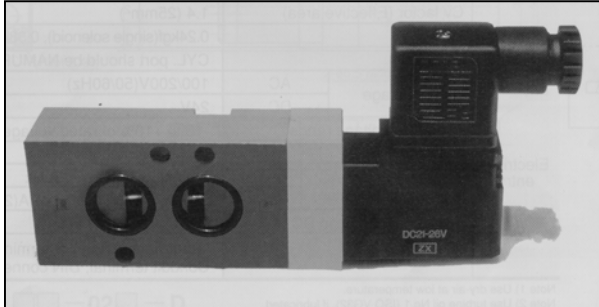

**Application:** Interface Solenoid Valve for Pneumatic Actuators

**Features:**

- NAMUR interface
- Electrical entry: conduit connection with terminals
- Manual override/classification: non-locking, push type (flush)
- Thread type: NPT

**Symbol**

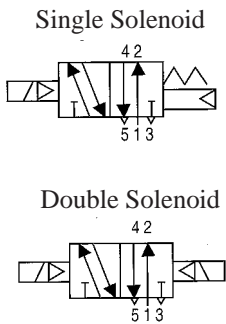

Specifications			
Valve	Fluid	Air, inert gas	
	Max. operating pressure	130 PSI (0.9 MPa)	
	Min. operating pressure	22 PSI (0.15 MPa)	
	Ambient and fluid temperature	14°F to 140°F (-10°C to 60°C) *	
	Lubrication	Not required **	
	Pilot operator manual override	Non-locking push type (Flush type)	
	Protection structure	Dust proof	
	Port size	1/4	
	Cv factor (effective area)	1.4 (1 in <sup>2</sup> , 25 mm <sup>2</sup> )	
	Weight	0.57 lb (0.26 kgf)	
	Other	Cyl. port should be NAMUR hole pattern	
Electrical Entry	Rated voltage †	AC 24/100/200 V (50/60 Hz)	
	Allowable voltage range	-15% to 10% of rated voltage	
	Coil insulation	Class B or equivalent	
	Apparent power AC (power consumption)	Inrush	5.0 VA / 60 Hz, 5.6 VA / 50 Hz
		Holding	2.3 VA (1.5 W) / 60 Hz 3.4 VA (2.1 W) / 50 Hz
	Power consumption DC	1.8 W	
	Electrical entry	Grommet, Grommet terminal, Conduit terminal, DIN connector	

**How to Order:**

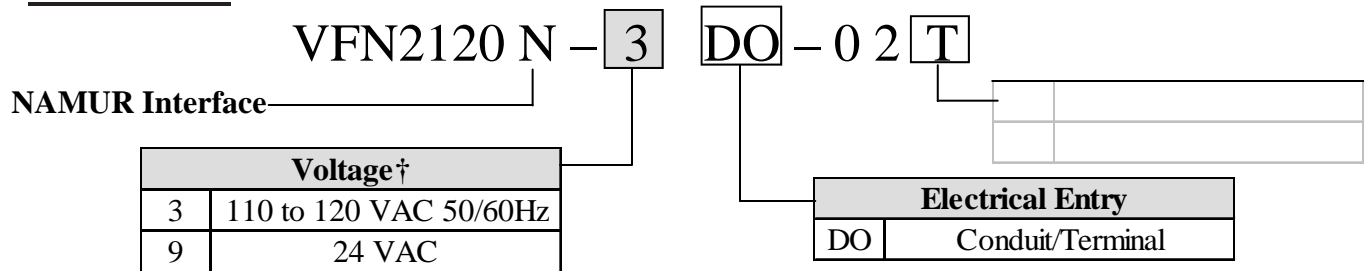

**Notes:**

- \* Use dry-air at low temperature
- \*\* Use turbine oil No. 1 (ISO VG32), if lubricated
- † Other voltages available with special order



## Low Pressure (20-30 PSI) Pneumatic Piston Type Spring Return Actuators for Butterfly Valves



The Pneumatic Piston Type Spring Return Actuators provide actuation on butterfly valves in sizes up to 10 inches.

These actuators are sized and installed for 70° disc rotation and require 20 to 30 PSIG (140 to 210 kPa) maximum input air pressure at the diaphragm to deliver the rated torque output.

Maximum Available Force* (lbs)				
Actuator Model No.	Stroke	20 PSIG Air Supply Nominal Spring Range (PSI)		
		3 to 7	5 to 10	8 to 13
PS-1	Power	195.0	150.0	105.0
	Return	45.0	75.0	120.0
PS-2	Power	–	–	163.8
	Return	–	–	187.2
PS-3	Power	–	–	163.8
	Return	–	–	187.2
PS-4	Power	–	–	327.6
	Return	–	–	374.4
PS-5	Power	–	–	327.6
	Return	–	–	374.4

**Notes:**

- Nominal Spring Range is the interval over which the piston moves from one extreme to the other when no external load is applied to the actuator. It is expressed in terms of the control pressure on the diaphragm.
- Return Force based on 0 PSIG supply.
- \* Work = Force x Stroke

Actuator Torque Comparison Data	
Actuator Model No.	Torque (in-lbs)/PSI**
PS-1	22.5
PS-2	46.8
PS-3	70.2
PS-4	93.6
PS-5	140.2

**Notes:**

- Total Torque = Supply Pressure - Spring Pressure x Torque/PSI (Power Stroke)
- Total Torque = Spring Pressure x Torque/PSI (Return Stroke)
- \*\* The torque is based on 90° angular rotation and computed for 1 PSI.



## Electronic Industrial and Pneumatic Actuators

### Electronic Industrial - NEMA 4/4X Type

RE Industrial Electronic Actuator General Specifications ..... AC-1-2

How to Select the RE Industrial Actuator Part Number ..... AC-3

RE Series Industrial Actuators Features and Benefits ..... AC-4

RE Series Industrial NEMA 4/4X Type Actuators  
Torque: 150 In-Lb to 10,200 In-Lb ..... AC-5-6

RE Current Limited Board Example Wiring  
For Two-Wire On/Off Control Applications ..... AC-7

RE Current Limited Board Example Wiring  
For Three-Wire Floating/Tri-State Control Applications ..... AC-8

RE Current Limited Board Example Wiring  
When Used With A Modulating Control Board ..... AC-9

RE Modulating Control Board Wiring ..... AC-10

Torque Maximizer ..... AC-11

### Pneumatic

Rack & Pinion Pneumatic Actuators ..... AC-12-14

Scotch Yoke Design Pneumatic Actuators  
PN2500, PN3500, PS2500 & PS3500 ..... AC-15

Pneumatic-Pneumatic Positioner: Rotary Type IP5100 ..... AC-16-18

NAMUR Interface 5 Port Solenoid Valve ..... AC-19

Low Pressure (20-30 PSI) Pneumatic Piston Type  
Spring Return Actuators for Butterfly Valves ..... AC-20