



DeKtec

Catalogue 2016

Introduction

Enabling PCs for Broadcast	03
A Short History	03
Organisation	04
What's New in 2016	04

PCI Express

DTA-2107 – Satellite Modulator	05
DTA-2111 – VHF/UHF Modulator	06
DTA-2115B – All-Standard, All-Band Modulator	07
DTA-2131 – SDR VHF/UHF Receiver	08
DTA-2136 – Dual Cable Receiver	09
DTA-2137C – Dual Satellite Receiver	10
DTA-2138B – DVB-T2/C2/ISDB-T Receiver	11
DTA-2139 – 12-Channel QAM Receiver	12
DTA-2144B – Quad ASI	13
DTA-2145 – Dual ASI	14
DTA-2152 – Dual HD-SDI	15
DTA-2154, DTA-2174 – Quad HD/3G-SDI/ASI	16
DTA-2160 – Triple ASI, GigE	17
DTA-2162 – Dual GigE	18
DTA-2179 – Twelve 3G-SDI/ASI Ports	19
DTA-2180 – H.264 HD Encoder	20
DTA-2181 – Dual H.264 HD Decoder	21
DTA-2182 – Dual H.264 HD Encoder	22
DTA-2195 – 12G-SDI In+Out with HDMI 2.0 Monitor	23

PCI Cards

DTA-107S2 – DVB-S2 Modulator	24
DTA-111 – VHF/UHF Modulator	25
DTA-115 – VHF/UHF Modulator	26
DTA-145 – Dual ASI	27
DTA-160 – Triple ASI, GigE	28

USB-2 Adapters

DTU-215 – VHF/UHF Modulator	29
DTU-236A – 8-VSB/QAM/ASI Probe	30
DTU-238 – DVB-T/T2, DVB-C and ASI Probe	31
DTU-245 – FantASI ASI Input/Output	32

USB-3 Adapters

DTU-315 – VHF/UHF/L-band Modulator	33
DTU-350, DTU-351 – HD-SDI Output, Input	34

IP Converters

DTE-3100 – IP to ASI	35
DTE-3114 – Quad QAM Modulator	36
DTE-3120 – ASI to IP	37
DTE-3137 – DVB-S2 to IP	38
DTE-RCK1 and DTE-STAND	39
DTM-3200 – IP to/from ASI	40
DTM-3224 – Quad ASI to IP Converter	41
DTM-3237 – DVB-S2 to ASI	42

Applications

DTC-300 – StreamXpress®	43
DTC-320 – StreamXpert®	44
DTC-335 – SdEye	45
DTC-342 – T2Xpert	46
DTC-343 – C2Xpert	47
DTC-378 – T2Xpress	48
DTC-379 – C2Xpress	49
DTC-382 – TmmXpress	50
DTC-700 – MuxXpert	51
DTC-706 – MuxXpert API	52
DTC-720 – Xpect®	53
DTC-720 – Xpect® Mosaic	54

Software Development Kits

DTAPI – DekTec SDK	55
DTAPI-TS – Analysis SDK	56

Sales

Distributors	57
Open Pricing	57
OEM	57
Warranty	57

The best way to predict the future
is to invent it.

Alan Kay

Enabling PCs for Broadcast

DekTec designs and manufactures PC add-on cards, USB- and IP devices, and software for the professional digital-television market. Our devices can be used in three ways

1. For Test & Measurement purposes;
2. To build broadcast infrastructure;
3. As OEM component integrated in your product.

We are pleased to see that our products are widely deployed by virtually every company operating in the digital-television field. The future looks bright, with a roadmap loaded with exciting new products.

Sito Dekker

The astonishing advances in PC technology have enabled the creation of real-time applications never thought possible. DekTec supplies the missing pieces to build complete applications in the form of interface adapters to route digital-TV signals in and out of the PC, and optimized software components to perform the signal processing. The economy of scale provided by the PC platform, combined with DekTec's multi-purpose interface devices and software, enable an exceptional price to performance ratio.

It is our mission to provide digital-TV professionals with innovative, best-in-class hardware and software to successfully deploy PCs in digital-television solutions.

A Short History

DekTec Digital Video was founded in 2000 by two engineers coming from Philips Digital Video Systems, Sito Dekker and Maarten Ghijsen, currently CEO and Head of Development of DekTec.

DekTec's first products, DVB-ASI and DVB-SPI output adapters for PCI bus, were launched in 2001, together with the *StreamXpress*® playout software. A steady stream of new PCI, PCI Express and USB devices followed. In 2004, the first USB device in the FantASI family was introduced, along with *StreamXpert*® transport-stream analyser. Immediately, these won prestigious industry awards at NAB and IBC.

StreamXpress® and *StreamXpert*® have evolved into the industry-standard toolset for digital-TV field work.

In addition to the growing range of transport-stream and SDI adapters, DekTec has been at the forefront of test modulators. This product line started in 2004 with the DTA-107 satellite modulator for PCI bus, followed by several VHF/UHF modulators. In 2015 the modulator line was completed with two high-end test modulators, agile over VHF, UHF and L-band, supporting all current cable, terrestrial and satellite standards: The DTA-2115B for PCIe and the portable DTU-315 for USB-3 bus.

At the software front, DekTec licensed software-multiplexing technology from Philips and extended it to create the most versatile multiplexing platform in the market, the MuxXpert. In 2005 work was started to create an innovative monitoring solution from the ground up. The result, Xpect®, was brought on the market at the end of 2009, immediately winning a Pick Hit award at NAB 2010.

An extraordinary achievement in applying software technology was completed by Fabrice Bellard, who started working for DekTec in 2006. He developed software-defined modulators and receivers for nearly all digital-TV modulation

standards, running on standard x86 processors. This software machinery, together with state-of-the-art all-digital upconversion hardware, has enabled DekTec to become the leading supplier of test modulators and receivers, actively involved in the development of new standards like ATSC 3.0.

All in all, since the first product introduction in 2001, the hardware and software product range has grown into the complete and consistent product portfolio you can find in this catalogue and on our website www.dektec.com

Organisation

All hardware products are manufactured in the Netherlands. DekTec has built up a sizeable engineering and distribution force, with its head office in Hilversum, two wholly owned sales offices in USA and UK, and development centers in Hilversum, Eindhoven and Denver. More than 40 appointed distributors cover all regions in the world.

DekTec is a member of DVB and ATSC, actively contributing to the development of ATSC 3.0. DekTec is also a registered member of HDMI, IABM, PCI-SIG, SMPTE, USB Forum and VSE.

What's New in 2016

- **DTA-2115B**

The B version of the DTA-2115 supports a firmware variant with eight 8-MHz modulators, each fully agile over the VHF and UHF band.

- **DTA-2153**

An attractively-priced PCIe card with three HD-SDI inputs and one HD-SDI + HDMI-monitoring output.

- **DTA-2175**

A tiny PCIe card with 3G-SDI/ASI input, output and a failover relays.

- **DTA-2195**

A PC interface for 12G-SDI and HDMI 2.0.

- **DTM-3204**

OEM module for converting IP to four ASI ports.

- **DTU-315**

A new, quiet fan has been fitted and full support for ATSC 3.0 added.

**Strive not to be a success,
but rather to be of value.**

Albert Einstein

DTA-2107

Multi-Standard L-Band Modulator

PCI Express

Features

- Satellite modulator with integrated agile L-band upconverter
- DVB-S and DVB-S2 modulation with support for all constellations (incl. 16APSK and 32-APSK) and all roll-off factors (0.20, 0.25, 0.35)
- ISDB-S modulation option with command-line multiplexer to create a valid ISDB-S stream with TMCC data from a standard Transport Stream
- Programmable output level
- AWGN inserter option
- Free Windows and Linux SDK (DTAPI) is fully compatible with other DekTec digital-video output adapters
- PCI Express x1, low profile
- Low profile and standard profile PCI brackets available

Applications

- With *StreamXpress*[®]: Multi-purpose satellite-TV RF signal-generator for R&D, demos, exhibitions, repair
- With MuxXpert: Real-time generation of a DVB-S(2) / ISDB-S signal for single Transport Streams
- With DTAPI: Create your own OEM application that generates a satellite-TV RF signal



Complete DVB-S(2), ISDB-S modulator
Fully agile from 950 to 2150 MHz
AWGN insertion

Key Attributes

Parameter	Value
Modulation	DVB-S(2), ISDB-S, DAB+, I/Q
DVB-S2 constellations	QPSK, 8PSK, 16/32APSK
Roll-off factor	0.20, 0.25, 0.35
Channel filter	256 taps
Symbol rate	0.088 to 45MBd
Symbol rate resolution	<30mBd
Output connector	75-Ω F female
Return loss	>14dB (950 to 2150MHz)
RF output frequency	950 to 2150MHz
RF output level (DVB-S2)	-46.5 to -15.0dBm
RF output level (DVB-S)	-41.5 to -10.0dBm
Phase noise	<-95dBc @ 10kHz
Spurious	>50dB (950 to 2150MHz)
PCI Express	PCIe1 x1 low profile
OS	XP/2k3/Vista/2k8/7/8/10 Linux ≥2.6.18, 3.x, 4.x

Modulation Standards

Modulation	Standard
DAB+*	EN 300 401
DVB-S	EN 300 421
DVB-S2	EN 302 307
I/Q*	Arbitrary I/Q samples
ISDB-S*	ARIB STD-B20

* Option

Ordering Information

Type	Description
DTA-2107-SP *	L-band modulator with <i>StreamXpress</i> [®]
DTC-305-CM	AWGN inserter option
DTC-371-IQ	IQ sample payout option
DTC-373-IS	ISDB-S modulation option
DTC-376-DAB	DAB modulation option

* Supports DVB-S and DVB-S2

DTA-2111

Multi-Standard VHF/UHF Modulator

PCI Express

Features

- Multi-standard modulator for PCI Express with support for most QAM-, OFDM- and VSB-based modulation standards
- Digital upconversion for excellent signal quality without need for calibration
- Supports all constellations and modulation modes for each supported standard
- All-channel upconverter 36 to 1002MHz fully agile over VHF and UHF band
- Digital channel simulator option
- RF output for direct connection to the antenna input of a digital receiver
- Free Windows and Linux SDK (DTAPI) is fully compatible with other DekTec digital-video output adapters
- PCI Express x1, low profile

Applications

- General purpose test modulator
- SMATV, hotel server, shows and exhibitions
- OEM applications



All-digital multi-standard modulator
Fully agile from 36 to 1002MHz
Upgradable to support new standards

Key Attributes

Parameter	Value	
RF connector	75-Ω F female	
Frequency range	36 to 1002MHz ±3ppm	
Bandwidth (max)	8MHz, 16MHz (option)	
I/Q sample rate	4.7 to 9.375MHz	
Level	Range	-32 to -9dBm (QAM) -35 to -12dBm (OFDM)
	Step size	0.1dB
	Accuracy	±2dB
MER	>40dB	
Adjacent channel		-54dB (QAM) -52dB (OFDM)
Phase noise	<-95dBc @ 100kHz	
Spectral purity	>50dB @ -9dBm	
Wideband noise	35dBμV (B=1MHz)	
PCI Express	PCIe1 x1 low profile	
OS	XP/2k3/Vista/2k8/7/8/10 Linux ≥2.6.18, 3.x, 4.x	

Modulation Standards

Standards
ADTB-T*, ATSC, ATSC-M/H*, CMMB*, DAB+*, DMB-T/H*, DVB-C, DVB-C2*, DVB-T, DVB-T2*, I/Q samples*, ISDB-T*, ISDB-Tmm*, QAM-B, QAM-C, T-DMB*

* Option

Ordering Information

Type	Description
DTA-2111-SP	VHF/UHF modulator with <i>StreamXpress</i> ®
DTA-2111-GOLD	DTA-2111 with all options
DTC-371-IQ	I/Q sample payout option
DTC-380-16MHZ	16-MHz bandwidth option
DTC-381-T2SPLP	DVB-T2 single PLP option
DTC-382-Tmm	ISDB-Tmm option
DTC-384-SWMC	Multi-channel software modulation option

DTA-2115B

All-Standard, All-Band Modulator

PCI Express

Features

- High-end test modulator for PCIe with support for all popular digital-TV modulation standards
- All-digital modulation
- Wideband upconverter 32 to 2186MHz, fully agile over VHF, UHF and L-band
- Digital channel simulator option including multipath echo and phase noise simulation
- Ultra low phase noise
- 10-MHz/1pps input for SFN operation or board-to-board synchronization
- Free Windows and Linux SDK (DTAPI) is compatible with DekTec's other modulators and digital-video output adapters

Eight-Channel Firmware

- With the DTC-385-HW8CH option, the DTA-2115B operates as eight independent 8-MHz modulators
- Each modulator is fully agile over the VHF and UHF band (no dependencies between modulators)
- Any combination of terrestrial and cable modulation standards is supported

Applications

- The ultimate test modulator in the lab
- Generation of a network of channels in a test and validation environment using *StreamXpress*[®]
- Play back of I/Q samples up to 72MHz bandwidth



Fully agile from 32 to 2186MHz
Single 72-MHz or eight 8-MHz channels
Supports new DVB-S2 extensions (DVB-S2X)

Key Attributes

Parameter		Value
Main output	RF connector	50-Ω SMA female
	RF level	-60 to 0dBm
	Step size	0.1dB
Monitor output	RF connector	75-Ω F female
	RF level	-45dBm
10-MHz/1pps input		2x 50-Ω BNC female
Frequency range		32 to 2186MHz
Symbol rate		88kbaud to 85Mbaud
I/Q sample rate		88kHz to 85MHz
Bandwidth (max)		72MHz
Transmit MER (typical)		42dB
Phase noise		<-110dBc @ 10kHz
Spectral flatness over 8MHz		0.5dB
Spectral purity		>50dB
PCI Express label		PCIe3 x1
OS		XP/2k3/Vista/2k8/7/8/10 Linux ≥2.6.18, 3.x, 4.x

* If the DTA-2115B is used in a PCIe gen 2 slot, certain sample rate restrictions will apply.

Modulation Standards

Standards
ADTB-T*, ATSC, ATSC-M/H*, ATSC 3.0*, CMMB*, DAB+*, DMB-T/H*, DVB-C, DVB-C2*, DVB-S, DVB-S2, DVB-S2X*, DVB-T, DVB-T2*, I/Q samples*, ISDB-S*, ISDB-T*, ISDB-Tmm*, QAM-B, QAM-C, T-DMB*

* Option

Ordering Information

Type	Description
DTA-2115B-SP	All standard, all-band modulator for PCIe with <i>StreamXpress</i> [®]
DTA-2115B-GOLD	DTA-2115B-SP with all current and future modulation options
DTC-371-IQ	I/Q sample payout option
DTC-380-16MHZ	16-MHz bandwidth option
DTC-381-T2SPLP	DVB-T2 single PLP option
DTC-382-Tmm	ISDB-Tmm option
DTC-384-SWMC	Multi-channel software modulation option
DTC-385-HW8CH	8-channel modulation firmware option

DTA-2131

Multi-Standard VHF/UHF Receiver

PCI Express

Features

- Tuner, I/Q demodulator and sample-rate converter, optimized for use with SDR technology (Software Defined Radio = demodulation in software)
- Several software demodulators available, including DVB-C2 and DVB-T2, with features and measurements exceeding those of consumer demodulator chips
- Hardware sample rate converter for obtaining I/Q samples at a convenient rate (requires DTC-361-IQ option)
- MER measurements in OFDM up to an accuracy of 42dB
- Multiple demodulated streams and advanced measurements available through Advanced Demodulator API (available for Windows and Linux, part of DTAPI)
- PCI Express x1, low profile
- Low profile and standard profile PCI brackets available

Applications

- RF network monitoring with measurements
- Universal receiver
- Front end for SDR experiments

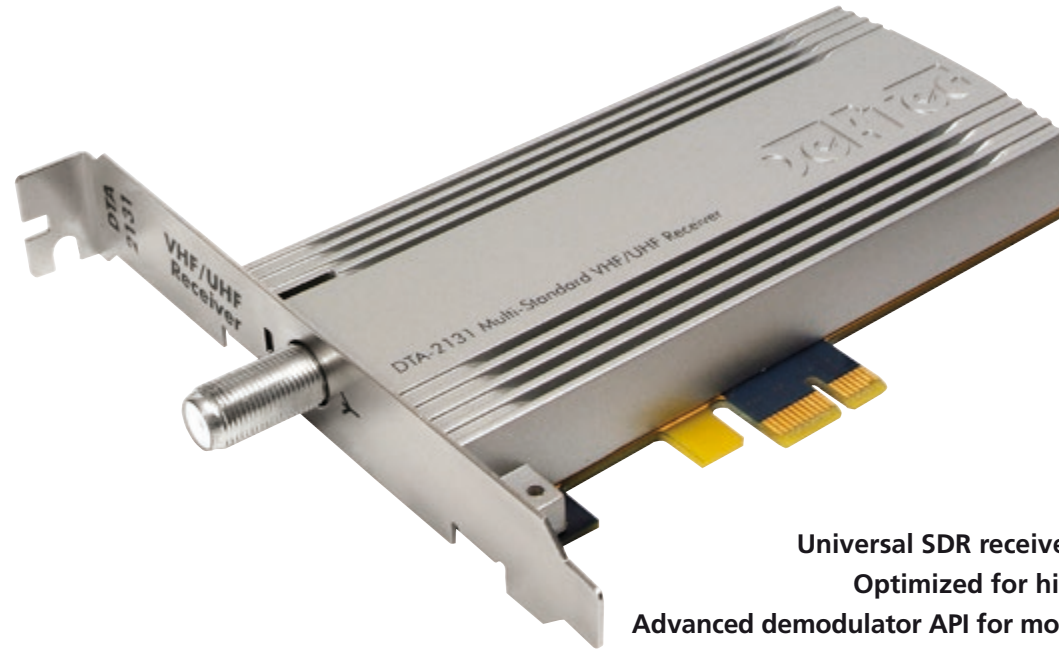

Universal SDR receiver for VHF/UHF band
Optimized for high-quality reception
Advanced demodulator API for monitoring applications

Key Attributes

Parameter	Value	
RF input	75-Ω F female	
Input return loss	>8dB	
Tuning range	42 to 870MHz	
Bandwidth	1.7, 6, 7, 8, 10MHz	
Input sensitivity	-90 to -20dBm	
I/Q sample rate	1.25 to 40Msps	
I/Q sample size	16-bit I + 16-bit Q	
SNR	50dB	
Metrology	MER	10 to 42dB
	RF level	-90 to -20dBm
	RF level accuracy	±3dB
Power consumption	4.7W typ	
Environmental temperature	0 to 45°C	
PCI Express	PCIe1 x1 low profile	
OS	XP/2k3/Vista/2k8/7/8/10 Linux ≥2.6.18, 3.x, 4.x	

Received Standards

Type	Description
DAB+	EN 300 401
DVB-C2	EN 302 769
DVB-T	EN 300 744
DVB-T2	EN 302 755
ISDB-T	ARIB STD-831

Ordering Information

Type	Description
DTC-360-RXA	Advanced demodulator option
DTC-361-IQ	I/Q sample reception option
DTC-362-T2MI	T2MI output option
DTA-2131-RXA-SX	DTA-2131 with <i>StreamXpert® Lite</i> and <i>StreamXpert®</i> and advanced RF analysis
DTA-2131-GOLD	DTA-2131 with all advanced demodulation options

DTA-2136

Dual QAM-A/B/C Receiver with ASI Monitoring Ports

PCI Express

Features

- Dual-channel QAM receiver, compliant with J.83 Annex A (DVB-C), B and C
- Applications have access to the complete Transport Stream
- Two DVB-ASI output ports for monitoring the receiver output
- ASI ports can also be used as independent general-purpose ASI outputs
- Each channel provides reception status, RF level, demodulation status, constellation, SNR, MER, pre- and post-FEC BER
- Free Windows and Linux SDK (DTAPI) is fully compatible with other DekTec digital-television adapters
- PCI Express x1

Applications

- Monitoring of cable networks (with *Xpect*®)
- Professional cable receiver

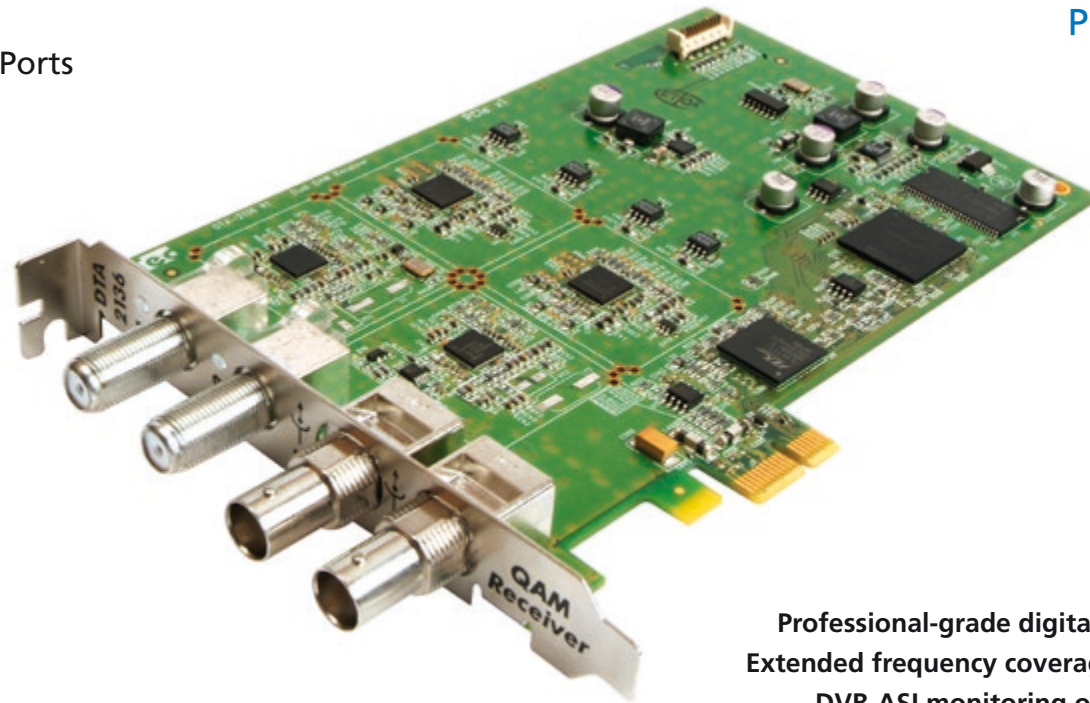

Professional-grade digital cable receiver
Extended frequency coverage to 1002MHz
DVB-ASI monitoring on each channel

Key Attributes

Parameter	Value	
RF inputs	2x 75-Ω "F" Female	
QAM standard	J.83 Annex A/B/C	
Input return loss	>10dB	
Tuning range	54 to 1002MHz	
Input sensitivity	-60 to -30dBm	
Symbol rate	5.0 to 7.1MBd	
Metrology	RF Level	-60 to -30dBm
	SNR	10 to 30dB
	MER	10 to 30dB
	BER	Pre/Post
	Constellation	2D
Receive-buffer size	2x 8MByte	
PCI Express	PCIe1 x1	
OS	XP/2k3/Vista/2k8/7/8/10 Linux ≥2.6.18, 3.x, 4.x	

Related Products

Type	Description
DTA-115-SP	Multi-standard VHF/UHF modulator supporting QAM-A/B/C
DTE-3114	Standalone quad QAM modulator with TS-over-IP input
<i>Xpect</i> ®	24/7 TS monitoring software

Ordering Information

Type	Description
DTA-2136-SLP	Dual QAM Receiver with <i>StreamXpress</i> ® and <i>StreamXpert</i> ® Lite
DTA-2136-SXP	DTA-2136-SLP bundled with <i>StreamXpert</i> ® TS analyser

DTA-2137C

Dual DVB-S2 Receiver with ASI Monitoring Ports

PCI Express

Features

- DVB-S2 receiver supports two channels in QPSK / 8-PSK mode or one channel in 16-APSK / 32-APSK mode
- Two ASI output ports can be used for monitoring or as independent output
- Reception and forwarding of BBFRAMEs
- Supports advanced DVB-S2 features: VCM, ACM, multiple input streams (MIS) and Generic Stream (GS)
- Dual LNB inputs or shared feed
- DVB-S2 demodulation compliant to EN302 307 and EN301 210, as well as legacy DVB-S support
- Implements all DVB-S2 modulation types including 16APSK and 32APSK
- Full LNB support with DiSEqC interface and 13V/18V 200mA supply (PCIe power) or 400mA with external power
- Each channel provides reception status: RF level, demodulation status, modulation type, code rate, MER, BER and error counts
- Programming interface (DTAPI) is fully compatible with other DekTec Digital-Video input adapters
- PCI Express x1

Applications

- Multipurpose DVB-S2 receiver
- Satellite data distribution
- Local redistribution of DVB-S2 channels with DekTec's remultiplexer MuxXpert

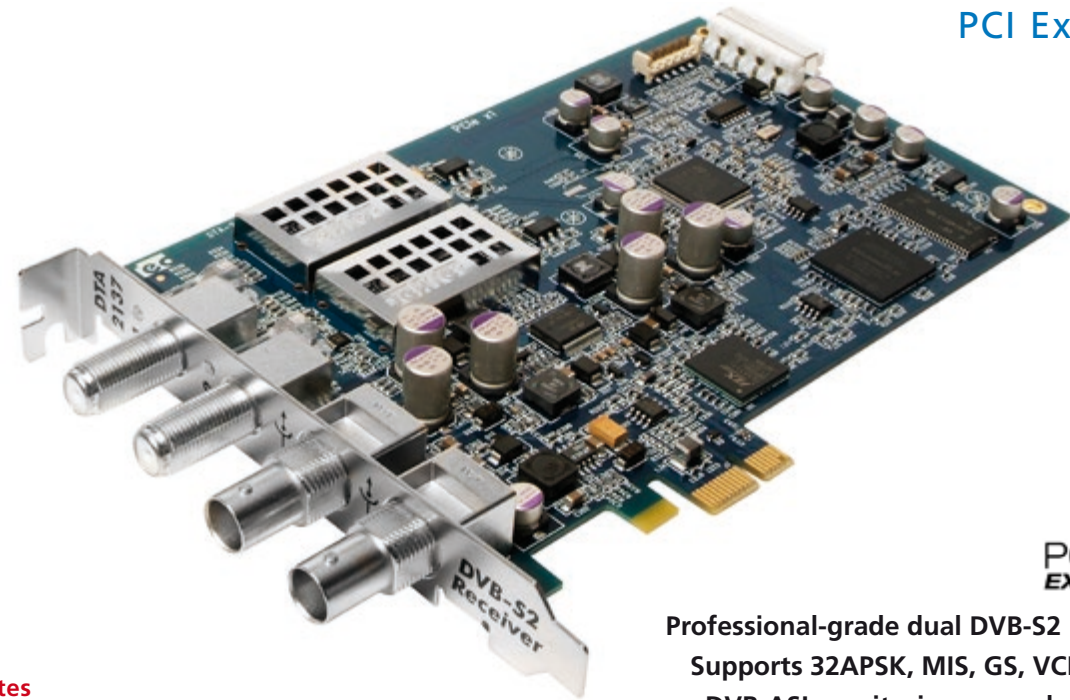

Professional-grade dual DVB-S2 receiver
Supports 32APSK, MIS, GS, VCM, ACM
DVB-ASI monitoring on each channel

Key Attributes

Parameter	Value	
Antenna inputs	2x 75-Ω "F" Female	
Input return loss	>10dB @ 0 to 1GHz > 4dB @ 1 to 2GHz	
Tuning range	950 to 2150MHz	
Input sensitivity	-60 to -30dBm	
Baud rate	2 to 40MBd	
Metrology	RF level	-60 to -30dBm ± 3dB
	SNR	0 to 22dB ±2dB
	MER	0 to 22dB ±2dB
	BER (DVB-S2)	Post BCH; Post LDPC
	BER (DVB-S)	Pre Viterbi; Pre RS
	Constellation	256 x 256
LNB supply (per channel)	13V/18V 400mA*	
Receive-buffer size	2x 8MBytes	
PCI Express	PCIe1 x1	
OS	XP/2k3/Vista/2k8/7/8/10 Linux ≥2.6.18, 3.x, 4.x	

* 200mA without 12V connected on HDD power connector

Related Products

Type	Description
DTA-107S2	DVB-S2 modulator with L-band upconverter for PCI bus
DTA-2107	Multi-standard L-band modulator for PCIe
MuxXpert	Real-time MPEG-2 multiplexer: Use DTA-2137C to remultiplex DVB-S2 channels for local redistribution

Ordering Information

Type	Description
DTA-2137C-SLP	Dual DVB-S/DVB-S2 Receiver with StreamXpress® and StreamXpert® Lite
DTA-2137C-SXP	DTA-2137-SLP bundled with StreamXpert® TS analyser

DTA-2138B

DVB-T2/C2/ISDB-T Receiver

PCI Express

Features

- Single-channel DVB-T2, DVB-C2 and ISDB-T receiver for VHF/UHF with support for DVB-T2 Lite
- Full support for legacy DVB-C and DVB-T
- Hardware-based demodulation with 0% CPU load
- Support for all DVB-T2 modes, including single and multiple PLP, SISO and MISO
- Professional RF measurements including RF level, MER and constellation diagram
- Free Windows and Linux SDK (DTAPI) is fully compatible with other DekTec digital-television adapters
- PCI Express x1, low profile
- Low profile and standard profile PCI brackets available

Applications

- Monitoring of DVB-T/T2, DVB-C/C2 or ISDB-T networks
- DVB-T/T2, DVB-C/C2, ISDB-T test receiver
- Re-multiplexing of DVB-C/T/C2/T2 or ISDB-T with DekTec's *MuxXpert* software



Professional-grade T2/C2 receiver
Optimized for monitoring applications
Enhanced reception algorithms and measurements

Key Attributes

Parameter	Value
RF input	75-Ω "F" female
Input return loss	>8dB
Tuning range	42 to 880MHz
Bandwidth	1.7/5/6/7/8 MHz
Input sensitivity	-80 to -15dBm
DVB-C	EN 300 429
DVB-C2	EN 302 769
DVB-T	EN 300 744
DVB-T2	EN 302 755 v1.3.1 (DVB-T2 Lite)
ISDB-T	ARIB STD-B31
PCI Express	PCIe1 x1 low profile
OS	XP/2k3/Vista/2k8/7/8/10 Linux ≥2.6.18, 3.x, 4.x

Related Products

Modulation	Standard
DTA-2131	Multi-standard VHF/UHF receiver
DTA-2136	Hardware-based QAM-A/B/C receiver
DTA-2137C	Hardware-based DVB-S2 receiver
DTA-2139	Twelve-channel QAM-A/B/C receiver

Ordering Information

Type	Description
DTA-2138B-SL	DVB-C2 / DVB-T2 receiver with <i>StreamXpert® Lite</i>
DTA-2138B-SX	DTA-2138B-SL with <i>StreamXpert®</i>

DTA-2139

Twelve-channel QAM-A/B/C receiver

PCI Express

Features

- High-density QAM-A/B/C receiver card with twelve independent receivers
- Applications have access to the complete Transport Stream for each channel
- RF signal is available on a loop-through output that can be connected to another DTA-2139. By cascading multiple DTA-2139s, a complete QAM network can be monitored
- Each channel provides reception status, RF level, demodulation status, constellation, SNR and post-FEC BER
- PCI Express x4
- Free Windows and Linux SDK (DTAPI) is fully compatible with other DekTec digital-video output adapters

Applications

- Monitoring of cable networks with Xpect®
- Testing and validation of edge-QAM systems

Note

This card can output the full Transport Stream but it cannot descramble services



Twelve independent QAM receivers
Full TS available from each receiver
Loop-through RF port for easy cascading

Key Attributes

Parameter	Value	
Input connector	75-Ω F female	
Return loss	>10dB	
Loop-through connector	75-Ω F female	
Loop-through attenuation	1.5dB typ.	
Tuning range	54 to 1002MHz	
Input sensitivity	-55 to -30dBm/channel	
Symbol rate	5.0 to 7.1MBd	
Metrology	RF level	-50 to -30dBm
	SNR	10 to 30dB
	BER	Post
	Constellation	2D
Receive-buffer size	12x 8MByte	
PCI Express	PCIe1 x4	
OS	XP/2k3/Vista/2k8/7/8/10 Linux ≥2.6.18, 3.x, 4.x	

Modulation Standards

Modulation	Standard
QAM-A (DVB-C)	EN 300 429
QAM-B	ITU J.83 Annex B
QAM-C	ITU J.83 Annex C

Ordering Information

Type	Description
DTA-2139-SL	Twelve-channel QAM receiver with <i>StreamXpert® Lite</i>
DTA-2139-SX	DTA-2139-SL with <i>StreamXpert®</i>

DTA-2144B

Quad ASI/SDI Adapter

PCI Express

Features

- Four ASI/SDI ports with individual status LEDs
- Each port can be independently configured as input, output or copy of another channel
- Cable equalisation and inverted ASI
- Support for genlock
- Hardware counters for bitrate measurement and statistics
- Flexible receive modes with time-stamping, packet sequence counting and false-sync pass through for full TR 101 290 support
- 10-bit SDI, full stream @ 270Mbit/s
- Lossless SDI Huffman encoding / decoding for reduction of bus bandwidth
- PCI Express x4

Applications

- Transport-stream multiplexing
- Monitoring of multiple MPEG-2 transport streams and/or SDI serial digital video streams
- Universal ASI/SDI input/output adapter for PC-based applications that record, play and/or process ASI or SDI

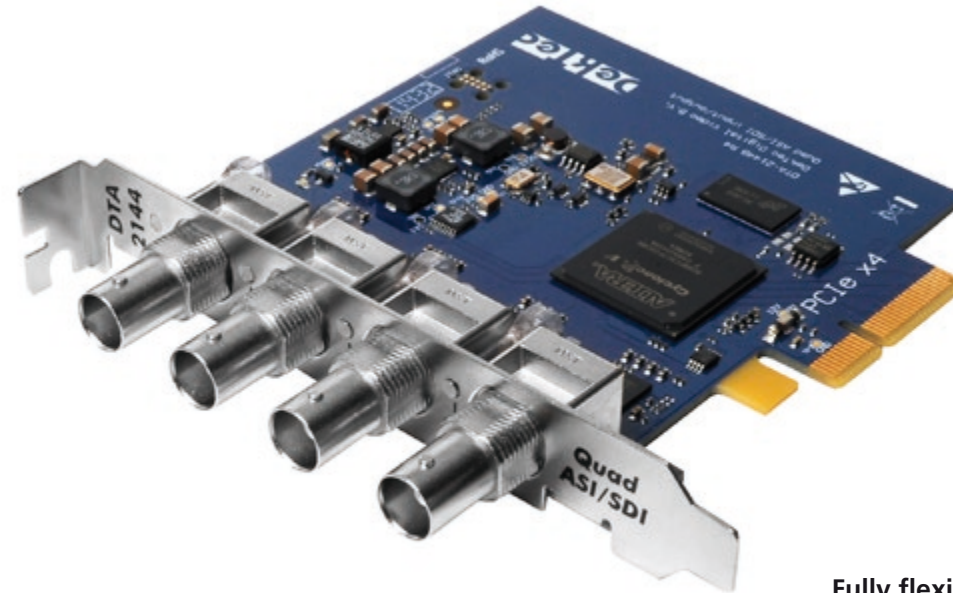

Fully flexible port configuration
PCI Express x4 for ample bandwidth
Supports DVB-ASI and full-frame SDI

Key Attributes

Parameter	Value	
ASI/SDI connector	75-Ω BNC (4x)	
Input return loss	>15dB	
Hardware buffering	32MB/channel	
ASI	Physical layer	DVB-ASI (coax) EN50083-9
	Rx or Tx bitrate	0 to 214Mbit/s
	Resolution	<1bit/s
SDI	Physical layer	SMPTE 259M/C
	Bitrate	270Mbit/s
	#Bits	8 or 10bit
PCI Express	PCIe1 x4	
OS	XP/2k3/Vista/2k8/7/8/10 Linux ≥2.6.18, 3.x, 4.x	

Related PCI-Express Products

Type	Description
DTA-2145	ASI/SDI input+output with fail-over
DTA-2152	Dual ASI/HD-SDI ports
DTA-2154	Quad ASI/HD-SDI ports
DTA-2174	Quad ASI/3G-SDI ports

Ordering Information

Type	Description
DTA-2144B-SLP	Quad ASI/SDI I/O adapter for PCI Express with <i>StreamXpress</i> ® and <i>StreamXpert</i> ® Lite
DTA-2144B-SXP	DTA-2144B-SLP with <i>StreamXpert</i> ®
DTA-2144B-SY-SLP	DTA-2144B-SLP with <i>SdEye</i>
DTA-2144B-SY-SXP	DTA-2144B-SLP with <i>SdEye</i> and <i>StreamXpert</i> ®

DTA-2145

Dual ASI/SDI Adapter

Features

- Two BNC ports: one dedicated ASI/SDI output port and one software-selectable ASI/SDI input- or second independent output port, with status LED
- All hardware and software features found in the market place, plus more
- Watchdog-controlled input-to-output relays for redundant configurations
- Support for genlock
- Cable equalisation and inverted ASI
- Bitrate measurement and statistics
- Flexible receive modes with time-stamping, packet-sequence counting and false-sync pass through for full TR 101 290 support
- Lossless SDI Huffman encoding / decoding
- PCI Express x1, low profile
- Low profile and standard profile PCI brackets available

Applications

- ASI/SDI stream station
- High-availability ASI/SDI generation
- ASI/SDI analysis or monitoring
- Universal ASI/SDI input/output adapter for PC-based applications that record, play and/or process MPEG-2 transport streams and/or SDI digital video

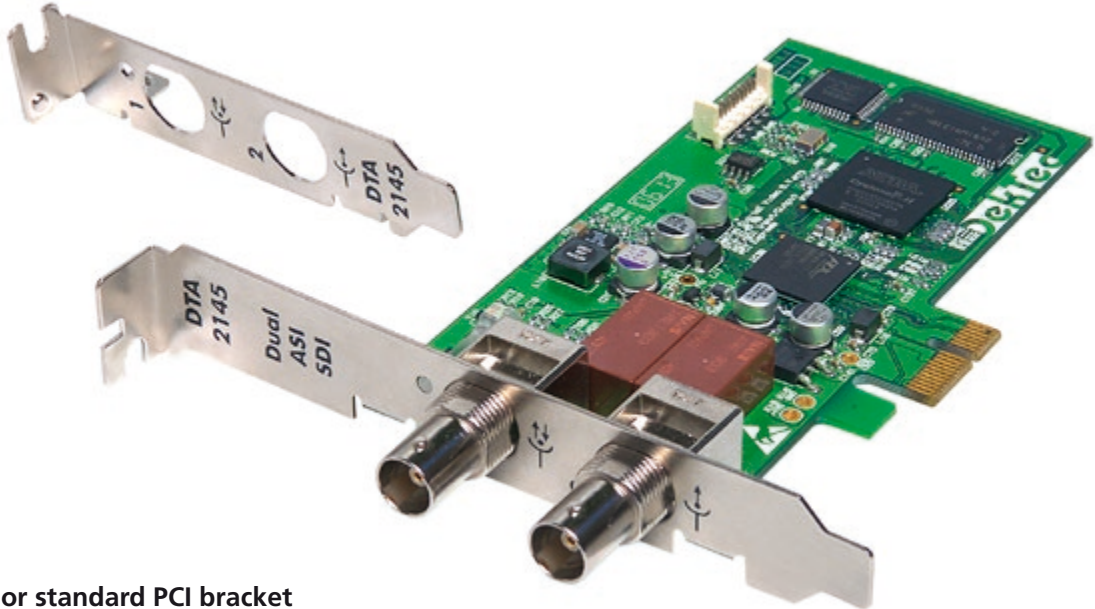

Low profile or standard PCI bracket
ASI/SDI input+output or dual output
Most complete feature set in the market

Key Attributes

Parameter		Value
Connector		75-Ω BNC (2x*)
Return loss		> 15dB
Hardware buffering		16MB/channel
ASI	Physical layer	DVB-ASI (coax) EN50083-9
	Bitrate range	0 to 214Mbit/s
	Packet size	188 or 204**
SDI	Physical layer	SMPTE 259M/C
	Bitrate	270Mbit/s
	#Bits	8 or 10bit
PCI Express		PCIe1 x1 low profile
OS		XP/2k3/Vista/2k8/7/8/10 Linux ≥2.6.18, 3.x, 4.x

* 1xOutput port and 1xsoftware-selectable input or output port
 ** Arbitrary packet size in raw mode

Related Products

Type	Description
DTA-145	Dual ASI/SDI adapter for PCI

Ordering Information

Type	Description
DTA-2145-SLP	Dual ASI/SDI I/O adapter for PCI Express with <i>StreamXpress</i> ® and <i>StreamXpert</i> ® Lite
DTA-2145-SXP	DTA-2145-SLP with <i>StreamXpert</i> ®
DTA-2145-SY-SLP	DTA-2145-SLP with <i>SdEye</i>
DTA-2145-SY-SXP	DTA-2145-SLP with <i>SdEye</i> and <i>StreamXpert</i> ®

DTA-2152

Dual HD-SDI / ASI Ports with Genlock

PCI Express

Features

- Dual-port HD-SDI adapter for PCI Express with analogue genlock input
- Each port can be independently configured as HD-SDI input or output
- Supports SD (SMPTE 259M) and HD (SMPTE 292M) signals
- Analogue genlock input accepts bi- and tri-level synchronization signals
- Hardware scaler for on-board 1/4 and 1/16 down sampling
- Comes with new Matrix API, which provides convenient C++ classes for line-based access to audio, video HANC and VANC
- Full frame capture and play-out
- Access to all 16 audio channels
- PCI Express x4, low profile
- Low profile and standard profile PCI brackets available



Each HD-SDI port can be input or output
Analogue genlock input
Random access to audio, video, HANC/VANC

Applications

- General purpose HD-SDI processor
- Key and fill generators
- HD-SDI recording and play-out
- Video encoding or transcoding

Key Attributes

Parameter	Value
Physical layer	DVB-ASI: EN50083-9 SD-SDI: SMPTE 259M HD-SDI: SMPTE 292M
Connectors	3x 75-Ω BNC
Ports	1,2: SDI (in or out) 3: Genlock input
Return loss	≥15dB @ 0 to 1.5GHz
HD format	720p and 1080i
Memory	256MB
PCI Express	PCIe1 x4 low profile
OS	XP/2k3/Vista/2k8/7/8/10 Linux ≥2.6.18, 3.x, 4.x

Supported Formats

Formats
525i59.94, 625i50
720p23.98, 720p24, 720p25, 720p29.97, 720p30, 720p50, 720p59.94, 720p60
1080p(sf)23.98, 1080p(sf)24, 1080p(sf)25, 1080p(sf)29.97, 1080p(sf)30, 1080i50, 1080i59.94, 1080i60

Ordering Information

Type	Description
DTA-2152	2x HD-SDI / ASI for PCIe
DTA-2152-SY-SXP	DTA-2152 with <i>SdEye</i> , <i>StreamXpert</i> ® and <i>StreamXpress</i> ®

DTA-2154, DTA-2174

Quad HD/3G-SDI/ASI Ports with Genlock

PCI Express

Features

- Each port is fully software configurable:
 - Input or output
 - ASI or SD/HD-SDI
 - 3G-SDI (DTA-2174)
- DTA-2174 generates or captures uncompressed Ultra-HD 4Kp50 and 4Kp60 streams following the SMPTE-425-5 quad-3G link standard
- Bi- and tri-level genlock input port
- Two RS-422 ports for controlling a deck
- Hardware provides efficient access to SDI frames:
 - Separation of audio and ancillary data
 - Conversion from and to 16-bit aligned values
 - Video scaler for generating previews
 - Sophisticated DMA engine
- DekTec SDK (DTAPI) provides the “plumbing” for real-time applications, so that you can focus on the actual SDI processing
- PCI Express x4, low profile
- Low profile and standard profile PCI brackets available

Applications

- General purpose processing with any combination of 3G/HD/SD-SDI or ASI inputs or outputs
- Video mixing and effect generators
- SDI monitoring, recording and/or play-out
- Video encoding or transcoding

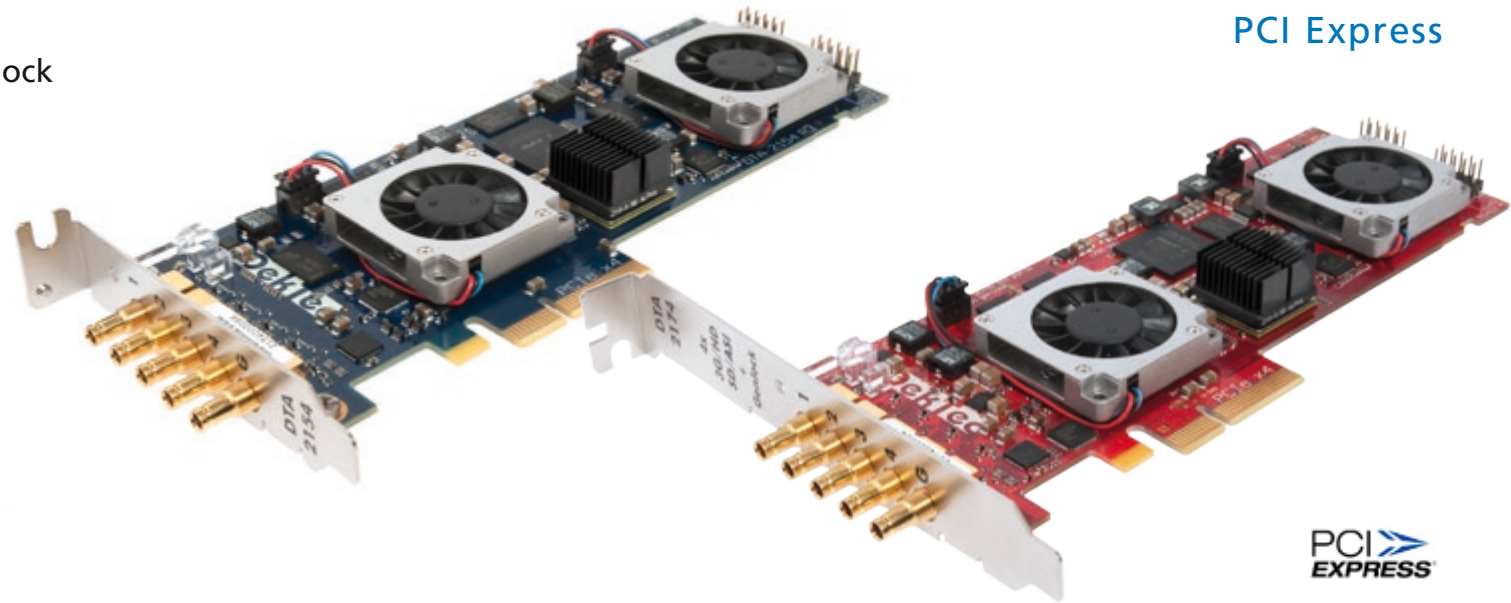

Real-time uncompressed 4Kp50/60 streaming (DTA-2174)
Efficient access to audio, video and ancillary data
Mixed ASI and SDI applications

Key Attributes

Parameter	Value
Physical layer	DVB-ASI: EN50083-9 SD-SDI: SMPTE 259M HD-SDI: SMPTE 292M 3G-SDI: SMPTE 424M level A/B
Connectors	5x 75-Ω 1.0/2.3 DIN plugs 2x 10p RS-422 header
Return loss	≥12dB @ 0 to 3GHz
Matrix API features	8/10/16-bit conversion Audio/video/ANC extraction Access to all 16 audio channels Hardware scaling by 1/4 or 1/16
PCI Express	PCIe3 x4 low profile
OS	XP/2k3/Vista/2k8/7/8/10 Linux ≥2.6.18, 3.x, 4.x

Supported Formats

Supported Formats
525i59.94, 625i50
720p23.98, 720p24, 720p25, 720p29.97, 720p30, 720p50, 720p59.94, 720p60
1080p(sf)23.98, 1080p(sf)24, 1080p(sf)25, 1080p(sf)29.97, 1080p(sf)30, 1080i50, 1080i59.94, 1080i60
DTA-2174: 1080p50, 1080p59.94, 1080p60
DTA-2174: 2160p50, 2160p59.94, 2160p60

Ordering Information

Type	Description
DTA-2154	4x HD-SDI / ASI for PCIe
DTA-2174	4x 3G/HD-SDI / ASI for PCIe
DTA-2154-SY-SXP	DTA-2154/2174 with <i>SdEye</i> , <i>StreamXpert</i> ®
DTA-2174-SY-SXP	DTA-2154/2174 with <i>SdEye</i> , <i>StreamXpert</i> ® and <i>StreamXpress</i> ®

DTA-2160

Triple ASI Ports and GigE Network Port

PCI Express

Features

- General-purpose transmission and reception of Transport Streams over ASI links and IP networks
- IP encapsulation in accordance with SMPTE 2022-1 and 2022-2
- Zero-jitter playout of multiple TS-over-IP streams
- Source-specific multicast (SSM) support
- Generation of two-dimensional FEC with programmable dimensions D and L and block-aligned FEC linearization
- Re-ordering and error correction of TS-over-IP streams with programmable latency
- Time stamping of incoming IP packets to enable TS-over-IP jitter analysis
- Comes with NDIS network driver for Windows and Linux network driver

Applications

- Contribution, primary distribution over IP
- Multipurpose ASI/TS-over-IP stream station
- Jitter measurements of TS-over-IP streams
- General-purpose ASI and TS-over-IP inputs and outputs for OEM applications

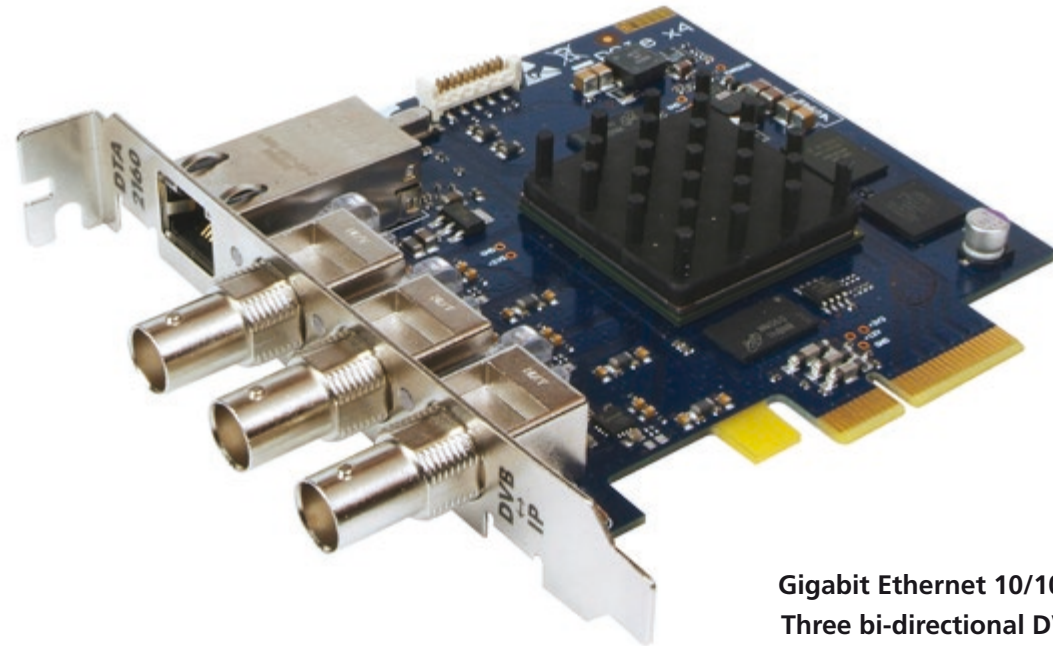

Gigabit Ethernet 10/100/1000 port
Three bi-directional DVB-ASI ports
Create your own IP/ASI stream station

Key Attributes

Parameter		Value
TS-over-IP	Physical layer	IEEE 802.3ab
	Data rate	10/100/1000
	Connector	RJ-45
	Maximum TS rate	600Mbit/s
	Parallel TS-over-IP streams	100+*
ASI	Physical layer	DVB-ASI (coax)
	Connector	75-Ω BNC (3x)
	Rx or Tx bitrate	0 to 214Mbit/s
	Resolution	<1bit/s
Transport packets per IP		1,2,3,4,5,6 or 7
TS-over-IP protocol		UDP or RTP
TS-over-IP FEC and Encapsulation		SMPTE 2022
Transcoding rate		0 to 200Mbit/s
PCI Express		PCIe1 x4
OS		XP/2k3/Vista/2k8/7/8/10 Linux ≥2.6.18, 3.x, 4.x

* Limited only by cumulative TS rate and PC resources

Related Products

Type	Description
DTA-160	Triple ASI and GigE port for PCI
DTA-2162	Dual GigE ports for PCIe
DTE-3100	Low-latency TS-over-IP to ASI converter
DTE-3120	Low-latency ASI to TS-over-IP converter
DTM-3200	OEM TS-over-IP from/to ASI converter

Ordering Information

Type	Description
DTA-2160-SLP	Triple ASI and GigE port for PCIe with <i>StreamXpress®</i> and <i>StreamXpert® Lite</i>
DTA-2160-J-SXP	DTA-2160-SLP with <i>DtJitter</i> and <i>StreamXpert®</i>

DTA-2162

Dual GigE Ports with Hardware Accelerated DTV Streaming

PCI Express

Features

- Two 100/1000 IEEE 802.3ab network ports enhanced with hardware-accelerated DTV streaming functions
- Greatly simplifies generation and consumption of TS-over-IP streams in your custom application
- Facilitates working with redundant TS-over-IP streams for creating highly-available networks
- Encapsulation and decapsulation of TS-over-IP streams with FEC support
- Hardware-based IP address filtering
- On-board packet scheduling engine for zero-jitter playout
- IP packet timestamping for jitter analysis or smoothing
- Supports TCP/IP task offloading to save CPU cycles
- Free Windows and Linux SDK (DTAPI) is fully compatible with other DekTec digital-television adapters
- Standard Windows and Linux network driver so that DTA-2162 ports can be used as standard network interface
- PCI Express x4, low profile
- Low- and standard profile PCI brackets available

Applications

- Monitoring of fully loaded Gigabit Ethernet links
- TS-over-IP processing of hundreds of streams
- Highly-available IP-based encoding, transcoding and multiplexing systems
- TS-over-IP stream station

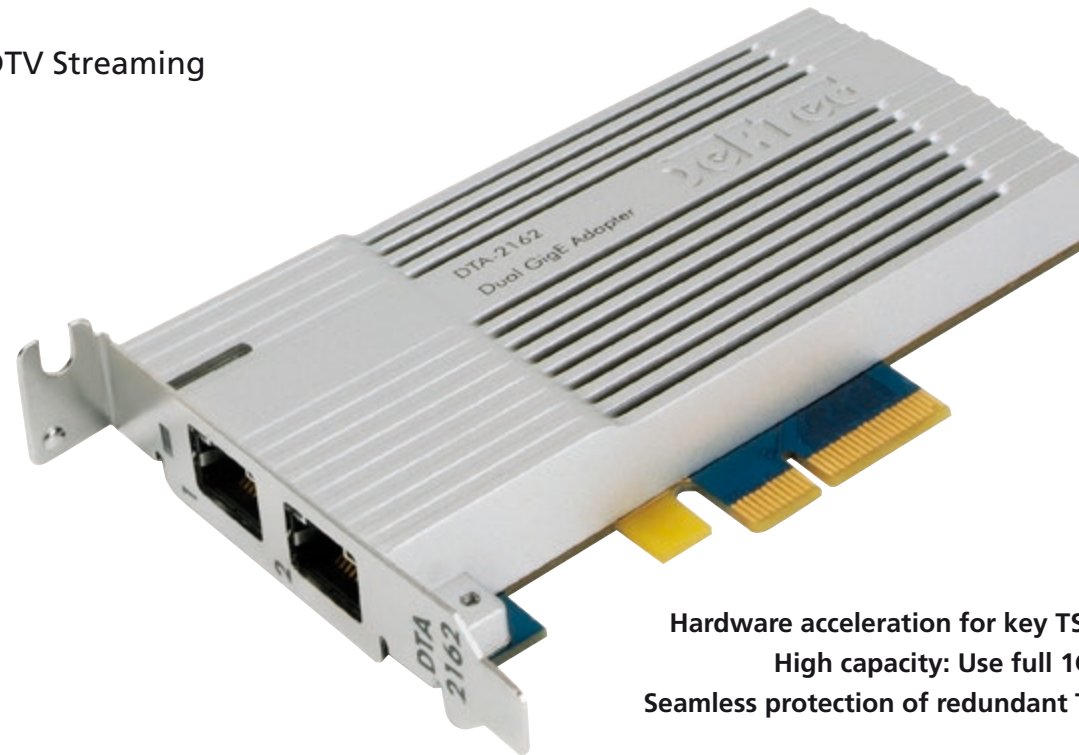

Hardware acceleration for key TS-over-IP functions
High capacity: Use full 1Gbps on each port
Seamless protection of redundant TS-over-IP streams (SMPTE 2022-7)

Key Attributes

Parameter	Value
Physical layer	IEEE 802.3ab
Ports	2x 100/1000 auto
Connector	RJ-45 with LEDs
IP protocol version	IPv4, IPv6
Seamless IP protection	SMPTE 2022-7
VLAN	IEEE 802.1Q
Maximum aggregated rate	1 Gbps per port
Parallel TS-over-IP streams	200+*
TS-over-IP protocol	UDP or RTP
IP FEC	SMPTE 2022-1
IP encapsulation	SMPTE 2022-2
PCI Express	PCIe1 x4 low profile
OS	XP/2k3/Vista/2k8/7/8/10 Linux ≥2.6.18, 3.x, 4.x

* Limited only by cumulative TS rate and PC resources

Related Products

Type	Description
DTA-160	Triple ASI and GigE port for PCI
DTA-2160	Triple ASI and GigE port for PCIe
DTE-3100	Low-latency TS-over-IP to ASI converter
DTE-3120	Low-latency ASI to TS-over-IP converter
DTM-3200	OEM TS-over-IP from/to ASI converter

Ordering Information

Type	Description
DTA-2162-SLP	Dual GigE ports for PCIe with <i>StreamXpress®</i> and <i>StreamXpert® Lite</i>
DTA-2162-J-SXP	DTA-2162-SLP with <i>DtJitter</i> and <i>StreamXpert®</i>

DTA-2179

Twelve 3G-SDI/ASI Ports with Genlock for PCIe

PCI Express

Features

- Twelve flexible ports, each independently configurable from software:
 - Input or output
 - 3G-SDI, HD-SDI, SD-SDI or ASI
- Each group of four ports supports 4K UHD transmission or reception using the SMPTE 425-5 quad 3G-link standard; Both pixel and quarter-image (annex B) multiplexing are supported
- Graphics-card class PCI Express gen3 x16 interface avoids bus-bandwidth limitations
- Bi-level and tri-level genlock input port, or digital genlock through port 1
- Matrix API 2.0 framework takes care of all the plumbing for creating robust real-time SDI processing applications.
- Free drivers and SDK (DTAPI) for 32 and 64-bit Windows and Linux

Applications

- Processing UHD signals up to 4Kp50/60
- Monitoring/creating many SDI or ASI signals
- Live production mixer and effect generators
- Image processing with many cameras

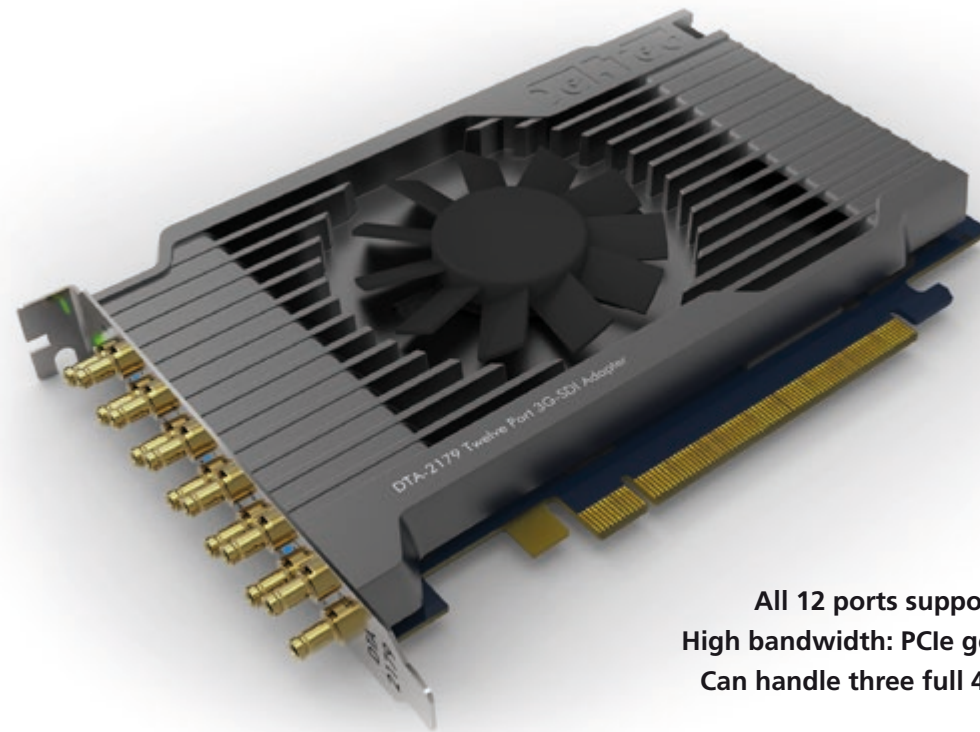

All 12 ports support 3G/HD/SD, ASI
High bandwidth: PCIe gen3 x16 interface
Can handle three full 4Kp50/60 streams

Key Attributes

Parameter	Value
Ports	12 SDI/ASI ports, 1 genlock port
Physical layer	DVB-ASI : EN50083-9 SD-SDI : SMPTE 259M HD-SDI : SMPTE 292M 3G-SDI : SMPTE 424M 4K : SMPTE 425-5 quad link
Connectors	13x 75-Ω DIN 1.0/2.3
Return loss	≥12dB @ 0 to 3GHz
Matrix API 2.0	8/10/16-bit conversion Audio/video/ANC extraction Hardware scaling by 1/4 or 1/16 Multiple stream synchronisation
PCI Express	PCIe3 x16
OS	XP/2k3/Vista/2k8/7/8/10 Linux ≥ 2.6.18, 3.x, 4.x

Supported Formats

Supported Formats
525i59.94, 625i50
720p23.98, 720p24, 720p25, 720p29.97, 720p30, 720p50, 720p59.94, 720p60
1080p(sf)23.98, 1080p(sf)24, 1080p(sf)25, 1080p(sf)29.97, 1080p(sf)30, 1080i50, 1080i59.94, 1080i60
1080p50, 1080p59.94, 1080p60
2160p50, 2160p59.94, 2160p60

Ordering Information

Type	Description
DTA-2179	Twelve 3G-SDI/ASI ports with genlock for PCI Express
DTA-2179-SLP	DTA-2179 with <i>StreamXpress®</i> , <i>StreamXpert® Lite</i>

Please refer to www.dektec.com for the latest pricing and a list of distributors and resellers.

NEW PRODUCT Please contact DekTec for availability

[Back to content](#)

DTA-2180

H.264 HD Encoder

PCI Express

Features

- Real-time, low latency MPEG-2 or H.264, SD or HD, video and audio encoder
- Audio encoding options: Dolby Digital (AC3), MPEG-1 Layer II, AAC, HE-AAC
- HD-SDI and HDMI input (one active)
- ASI output and data available on PCIe bus
- Use the HDMI input to encode the output of a PC's graphics card with high quality
- Supported on Windows and Linux by the free DekTec SDK (DTAPI), for easy mix and match with other DekTec I/O adapters
- Integrated in MuxXpert for combining multiple encoded services and adding tables
- Comes with *DtEnc*, a Windows application to set encoding parameters and check input and encoder status

Applications

- General purpose H.264 program encoder for contribution, production and distribution
- Encoding of PC desktop, running e.g. a PowerPoint or Prezi presentation
- H.264 encoding of Xpect Mosaic output

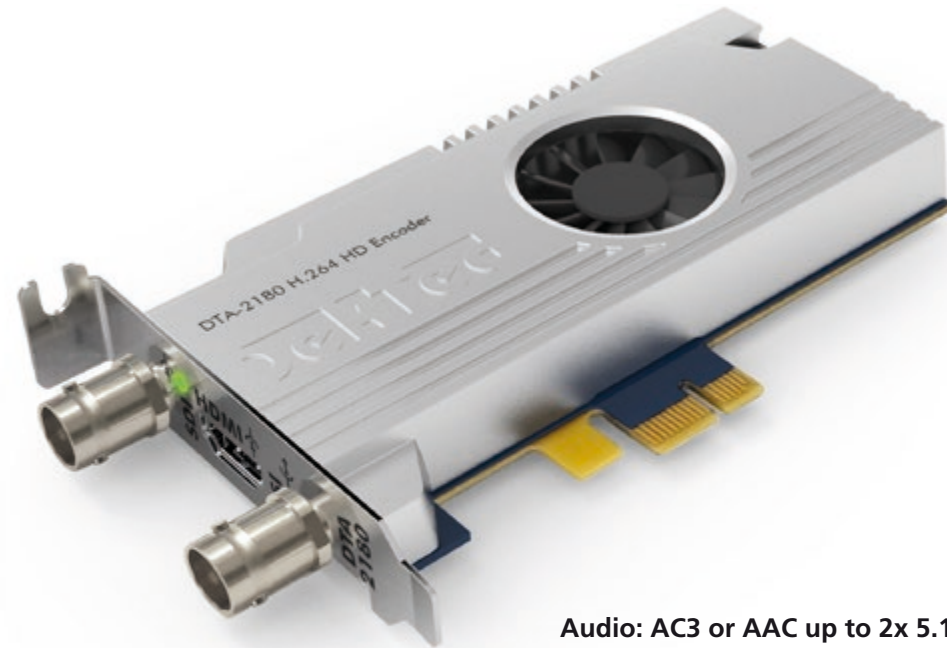

Audio: AC3 or AAC up to 2x 5.1, MPEG-1 Layer II
Built-in multiplexing with precise A/V sync
Encoder uses proven Magnum technology

Key Attributes

Parameter	Value
SDI input	SD, HD
HDMI input	HDMI 1.4a
Power connector	6-pin PCIe power
H.264 profiles	Main, high
MPEG-2 profiles	MP@ML/HL, HP@HL
Sample format	8-bit 4:2:0
#Audio channels	Up to 8x stereo or 2x 5.1
Ancillary data	Closed captions, XDS, AFD/BAR, VITC
Encoding latency	150/200/350/650ms
PCI Express	PCIe1 x1 +EXT25W low profile
OS	XP/2k3/Vista/2k8/7/8/10 Linux ≥2.6.18, 3.x, 4.x

Ordering Information

Type	Description
DTA-2180	Low-latency H.264 / MPEG-2 video encoder for SD and HD, without audio-encoding licenses
DTA-2180-AG0	H.264 HD contribution encoder for PCIe with AAC and/or MP1LII audio encoding for any number of channels (no AC-3 audio-encoding licenses)
DTA-2180-AG2	H.264 HD contribution encoder for PCIe with 2 license points (1x stereo) for AC-3 audio encoding, and AAC and/or MP1LII audio encoding for any number of channels

Please refer to www.dektec.com for more options and an on-line price calculator.

DTA-2181

Dual H.264 HD Decoder for PCI Express

PCI Express

Features

- Decoder variant of the DTA-2182
- Supports H.264 and MPEG-2 decoding in HD or SD resolution
- Transport stream can be sourced ASI input port for low-delay decoding, or from PCIe
- Decoded stream is available on two SDI outputs and on PCIe bus for processing by your application
- Audio decoding options: Dolby Digital (AC3), MPEG-1 Layer II, AAC, HE-AAC
- Closed captioning pass through
- Supported on Windows and Linux by the free DekTec SDK (DTAPI), for easy mix and match with other DekTec I/O adapters
- Standard applications available for controlling the decoder and for playout and decoding of compressed streams

Applications

- General-purpose H.264 HD decoder
- Multi-channel SDI test-signal generator
- PC applications that process uncompressed video, but which have H.264 input streams

NEW PRODUCT Please contact DekTec for availability

[Back to content](#)

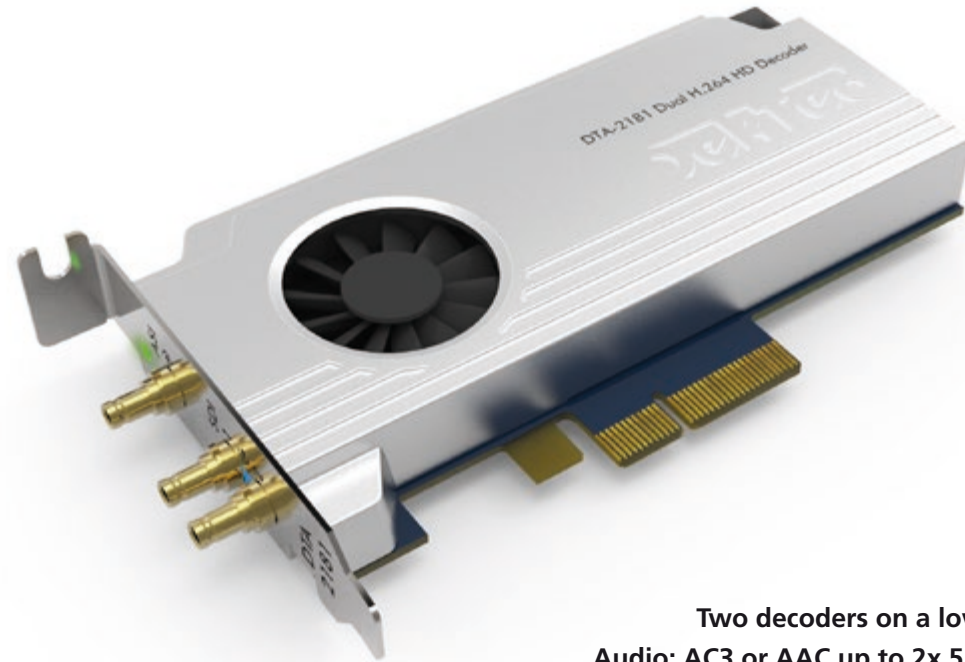

Two decoders on a low profile PCIe card
Audio: AC3 or AAC up to 2x 5.1, MPEG-1 Layer II
Precise audio/video synchronization

Key Attributes

Parameter	Value
Ports	1x 75-Ω 1.0/2.3 ASI input 2x 75-Ω 1.0/2.3 SDI output
Power connector	6-pin PCIe power
SDI input formats	SD, HD, 3G
H.264 profiles	Main, high
MPEG-2 profiles	MP@ML/HL, HP@HL
Sample format	8-bit 4:2:0
#Audio channels	Up to 8x stereo or 2x 5.1
Ancillary data	Closed captions, XDS, AFD/BAR, VITC
Decoding latency	100 ... 300ms
PCI Express	PCIe2 x4 +EXT25W, low profile
OS	XP/2k3/Vista/2k8/7/8/10 Linux ≥ 2.6.18, 3.x, 4.x

Ordering Information

Type	Description
DTA-2181	Dual H.264 decoder with stereo MP2-L2 or AAC audio decoding
DTA-2181-SP	DTA-2181 with <i>StreamXpress</i> ® and <i>DtDec</i>

Options

Option	Description
-AAC _n	<i>n</i> -channel AAC-LC audio decoding
-DD _n	<i>n</i> -channel AC3 audio decoding
-HE _n	<i>n</i> -channel HE-AAC audio decoding
-MP _n	<i>n</i> -channel MPEG1-LII audio decoding

A stereo service requires 2 channels, 5.1 requires 6 channels

DTA-2182

Dual H.264 HD Encoder for PCI Express

PCI Express

Features

- Dual-channel version of the DTA-2180
- Supports H.264 and MPEG-2 encoding in HD or SD resolution
- Two HD/3G-SDI inputs and two low-delay ASI outputs
- Video and audio samples can be sourced from the PCIe bus
- Multiplexing to transport stream, available on ASI outputs and on PCIe bus
- Audio encoding options: Dolby Digital (AC3), MPEG-1 Layer II, AAC, HE-AAC
- Closed captioning pass through
- Supported on Windows and Linux by the free DekTec SDK (DTAPI), for easy mix and match with other DekTec I/O adapters
- Standard applications available for controlling encoding parameters and for recording an encoded services

Applications

- Multi-channel H.264 HD encoder, e.g. for tunnelling multiple TV services over IP
- H.264 encoder for PC applications that generate TV channels and require the output to be encoded in H.264 or MPEG-2

NEW PRODUCT Please contact DekTec for availability

[Back to content](#)

Key Attributes

Parameter	Value
Ports	2x 75-Ω 1.0/2.3 SDI input 2x 75-Ω 1.0/2.3 ASI output
Power connector	6-pin PCIe power
SDI input formats	SD, HD
H.264 profiles	Main, high
MPEG-2 profiles	MP@ML/HL, HP@HL
Sample format	8-bit 4:2:0
#Audio channels	Up to 8x stereo or 2x 5.1
Ancillary data	Closed captions, XDS, AFD/BAR, VITC
Encoding latency	150/200/350/650ms
PCI Express	PCIe2 x4 +EXT25W, low profile
OS	XP/2k3/Vista/2k8/7/8/10 Linux ≥2.6.18, 3.x, 4.x

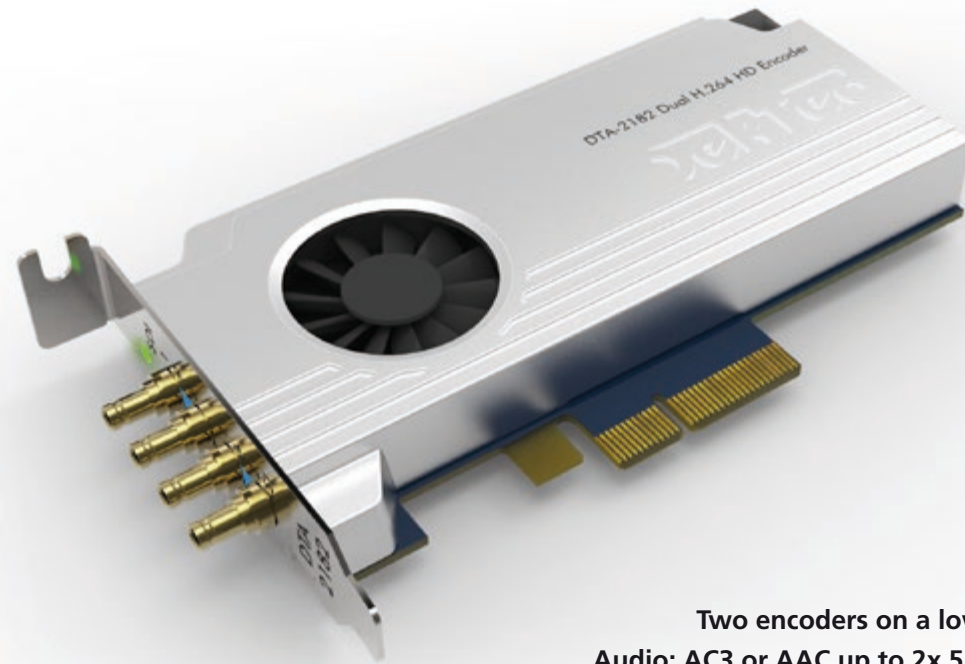

Two encoders on a low profile PCIe card
Audio: AC3 or AAC up to 2x 5.1, MPEG-1 Layer II
Built-in multiplexing with precise A/V sync

Ordering Information

Type	Description
DTA-2182	Dual H.264 encoder with stereo MP2-L2 or AAC audio service
DTA-2182-AG2	Dual H.264 HD encoder for PCIe with 2 license points (1x stereo) for AC-3 audio encoding, and AAC and/or MP1LII audio encoding for any number of channels

Please refer to www.dektec.com for more options and an on-line price calculator.

Options

Option	Description
-AAC _n	<i>n</i> -channel AAC-LC audio encoding
-DD _n	<i>n</i> -channel AC3 audio encoding
-HE _n	<i>n</i> -channel HE-AAC audio encoding
-MP _n	<i>n</i> -channel MPEG1-LII audio encoding

A stereo service requires 2 channels, 5.1 requires 6 channels

DTA-2195

12G-SDI I/O Adapter with HDMI 2.0 Monitor Output

PCI Express

Features

- 12G-SDI input port for ingesting UHD signals up to 4Kp50/60
- 12G-SDI output port with HDMI 2.0 copy for creating UHD signals up to 4Kp50/60
- Bi-level and tri-level genlock input port, or digital genlock through port 1
- PCI Express gen3 four-lane interface for ample bus bandwidth
- Hardware and Matrix API 2.0 provide efficient and convenient access to SDI frames:
 - Separation of audio (all channels) and ancillary data
 - On-board 1/4 or 1/16 video scaling for generating previews
 - Sophisticated DMA engine
 - Conversion from and to 16-bit data
- Free drivers and SDK (DTAPI) for Linux and Windows 7/8/10



**12G-SDI input and 12G-SDI output port
HDMI 2.0 port is copy of 12G-SDI output
Fully supported by Matrix API 2.0**

Applications

- General purpose I/O card for processing 12G-SDI streams in a PC
- ASI/SDI stream station (generator, analyzer) for all SDI rates up 12G-SDI
- 4K software encoder (H.264, HEVC) with 12G-SDI input and ASI output

Key Attributes

Parameter	Value
Ports	1x 12G-SDI input 1x 12G-SDI output 1x HDMI 2.0 output 1x genlock port
Physical layer	DVB-ASI : EN50083-9 SD-SDI : SMPTE 259M HD-SDI : SMPTE 292M 3G-SDI : SMPTE 424M 6G-SDI : SMPTE 2081 12G-SDI : SMPTE 2082
Connectors	3x 75-Ω BNC HDMI type A receptacle
Return loss	≥12dB @ 0 to 3GHz
PCI Express	PCIe3 x4
OS	Windows 7/8/10; Linux 2.6, 3.x, 4.x

Supported Formats

Supported Formats
525i59.94, 625i50
720p23.98, 720p24, 720p25, 720p29.97, 720p30, 720p50, 720p59.94, 720p60
1080p(sf)23.98, 1080p(sf)24, 1080p(sf)25, 1080p(sf)29.97, 1080p(sf)30, 1080i50, 1080i59.94, 1080i60
1080p50, 1080p59.94, 1080p60
2160p50, 2160p59.94, 2160p60

Ordering Information

Type	Description
DTA-2195	12G-SDI input/output port with HDMI 2.0 monitor output for PCIe
DTA-2195-SXP	DTA-2195 with <i>StreamXpress</i> ®, <i>StreamXpert</i> ®

NEW PRODUCT Please contact DekTec for availability

DTA-107S2

DVB-S2 Modulator with L-Band Upconverter

Features

- DVB-S2 modulator compliant to ETSI EN 302 307 (QPSK and 8PSK only; use DTA-2107 for APSK support)
- Integrated L-Band upconverter with on-board 950 to 2150-MHz synthesiser
- AWGN insertion option
- Complete broadcast-services modulator with BCH encoder, LDPC encoder, bit interleaver, constellation mapper and base-band shaping filter
- Supports all DVB-S2 defined code rates: 1/4, 1/3, 1/2, 2/5, 3/5, 2/3, 3/4, 4/5, 5/6, 8/9 and 9/10
- Can be operated in DVB-S mode
- DTA-107 can be upgraded to DTA-107S2 in the field with a simple procedure
- Free Windows software interface (DTAPI) that is fully compatible with other DekTec digital-video output adapters
- PCI rev 2.2, 32 bit, 33 or 66MHz bus

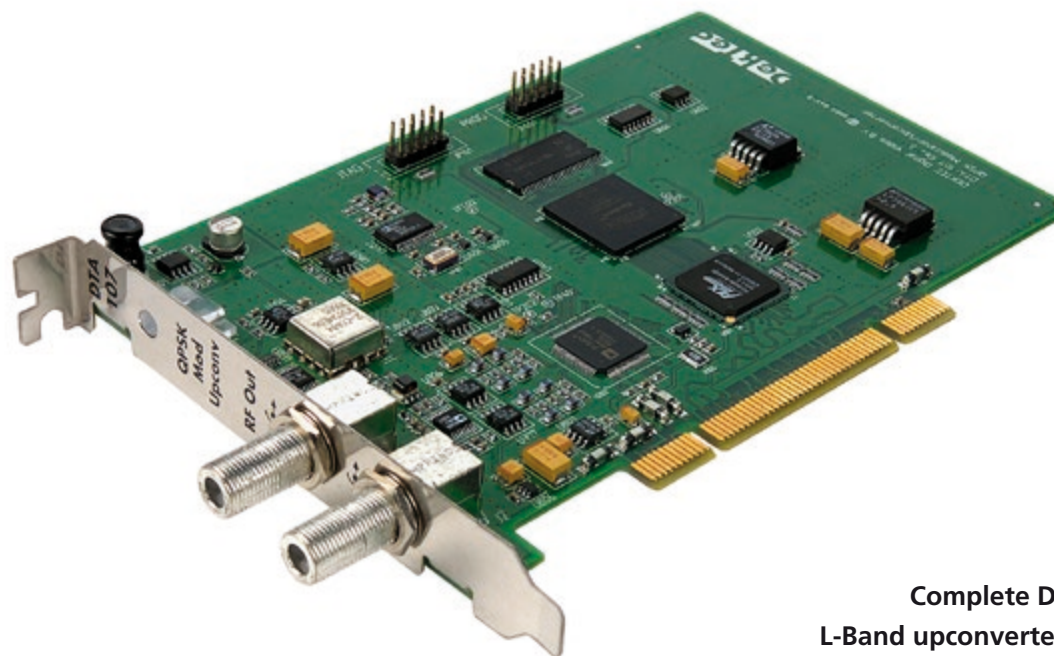

**Complete DVB-S2 modulator
L-Band upconverter 950...2150 MHz
ISDB-S modulation option**

Applications

- File-based DVB-S2 stream generator with output upconverted to L-band
- DVB-S/S2 modulator replacement
- DVB-S2 output for your (OEM) application

Key Attributes

Parameter	Value	
Modulation	QPSK, 8PSK	
Useful bitrate range	0 to 120Mbit/s	
Symbol rate	Range	1 to 45MBd
	Accuracy	±25ppm
	Resolution	<50mBd
RF output	Connector (2x)	F type, 75Ω
	Carrier frequency	950 to 2150MHz
	Accuracy	±1ppm
	Roll-off factor	0.35
	Output level	-30 ±3dBm
	Spurious	>40dB
	Return loss	≥15dB

Modulation Standards

Modulation	Standard
DVB-S	EN 300 421
DVB-S2	EN 302 307
ISDB-S*	ARIB STD-B20

* Option

Ordering Information

Type	Description
DTA-107S2-SP	DVB-S2 modulator/upconverter with StreamXpress®
DTC-305-CM	AWGN insertion option
DTC-372-S2	DVB-S2 option for DTA-107
DTC-373-IS	ISDB-S modulation option

DTA-111

Multi-Standard Modulator with VHF/UHF Upconverter

Features

- Multi-standard modulator with support for most QAM-, OFDM- and VSB-based modulation standards
- Supports all constellations and modulation modes for each supported standard
- All-channel upconverter 47 to 862MHz fully agile over VHF and UHF band
- Fixed output level of -15.0dBm for QAM and -18.0dBm for OFDM
- RF output for direct connection to the antenna input of a digital receiver
- Programming interface (DTAPI) is fully compatible with other DekTec digital-video output adapters
- PCI rev 2.2, 32 bit, 33 or 66MHz bus

Applications

- General purpose test modulator
- SMATV, hotel server, shows and exhibitions
- OEM applications



Low-cost multi-standard modulator
Fixed output level
Upgradable to support new standards

Key Attributes

Parameter	Value
Frequency range	47 to 862MHz \pm 1ppm
Bandwidth	5.0 to 8.0MHz
MER (OFDM)	\approx 38dB (QAM) \approx 40dB (OFDM)
Connector	75- Ω F
Return loss	\geq 15dB (47 to 862MHz)
Level (QAM)	-15dBm (+34dBmV)
Level (OFDM)	-18dBm (+31dBmV)
Phase noise	$<$ -90dBc @ 10kHz
Spectral purity	$>$ 50dB (47 to 862MHz) $>$ 90dB (muted)
PCI compliancy	r2.2, 32-bit, 33/66MHz
OS	XP/2k3/Vista/2k8/7/8 Linux \geq 2.6.18, 3.x, 4.x

Modulation Standards

Modulation	Standard
ATSC VSB	ATSC A/53E
CMMB*	GY/T 220.1/2-2006
DAB+*	EN 300 401
DTMB*	GB 20600-2006
DVB-C	EN 300 429
DVB-C2*	EN 302 769
DVB-T / DVB-H	EN 300 744
DVB-T2*	EN 302 755
ISDB-T*	ARIB STD-B31
QAM	J.83 Annex A/B/C

* Option

Ordering Information

Type	Description
DTA-111-SP	VHF/UHF modulator with <i>StreamXpress</i> [®]
DTA-111-GOLD	DTA-111 with all options

DTA-115

Multi-Standard Modulator with VHF/UHF Upconverter

Features

- Multi-standard modulator with support for most QAM-, OFDM- and VSB-based modulation standards
- Supports all constellations and modulation modes for each supported standard
- Channel simulator available as option (DTC-305-CM *XpressSim*)
- All-channel upconverter 47 to 862MHz covering full VHF and UHF band
- Output amplifier with programmable 0 .. 31.5dB attenuator in 0.5dB steps
- Can be used with DTA-Plus to extend output-level range to -110 to +10dBm
- Independent bi-directional DVB-ASI port
- Programming interface (DTAPI) is fully compatible with other DekTec digital-video output adapters

Applications

- Multi-standard test generator
- Modulator replacement
- RF output for your (OEM) application

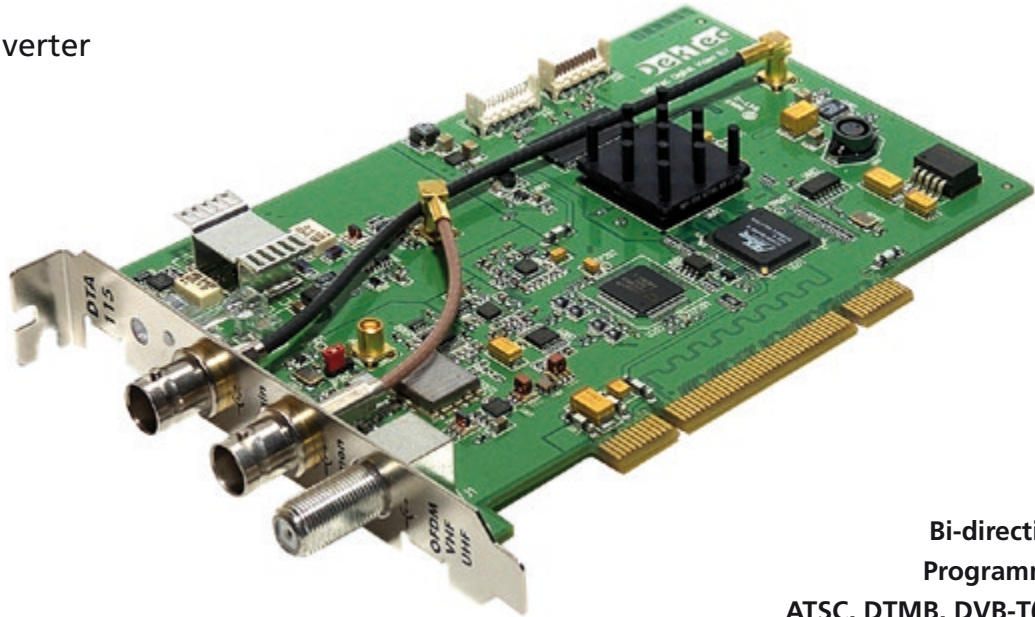

Bi-directional DVB-ASI port
Programmable output level
ATSC, DTMB, DVB-T(2)/H, ISDB-T, QAM

Key Attributes

Parameter	Value	
Frequency range	47 to 862MHz (± 1 ppm)	
Bandwidth	5.0 to 8.0MHz	
MER (OFDM)	≈ 40 dB	
Main output	Connector	50- Ω BNC
	Return loss	≥ 15 dB (47 to 862MHz)
	Level (QAM)	-31.5 to 0dBm ± 2 dB
	Level (OFDM)	-34.5 to -3dBm ± 2 dB
	Phase noise	< -90 dBc @ 10kHz
	Spectral purity	> 50 dB (47 to 862MHz)
Monitor output	Connector	75- Ω F
	Return loss	≥ 15 dB (47 to 862MHz)
	Level (QAM)	-27.5dBm ± 3 dB
	Level (OFDM)	-30.5dBm ± 3 dB
ASI	Connector	75- Ω BNC
	Return loss	≥ 15 dB (5 to 270MHz)
PCI compliancy	r2.2, 32-bit, 33/66MHz	

Modulation Standards

Modulation	Standard
ATSC VSB	ATSC A/53E
CMMB*	GY/T 220.1/2-2006
DAB+*	EN 300 401
DTMB*	GB 20600-2006
DVB-C	EN 300 429
DVB-C2*	EN 302 769
DVB-T / DVB-H	EN 300 744
DVB-T2*	EN 302 755
ISDB-T*	ARIB STD-B31
QAM	J.83 Annex A/B/C

* Option

Ordering Information

Type	Description
DTA-115-SP	Multi-standard VHF/UHF modulator with <i>StreamXpress</i> [®]
DTA-115-GOLD	DTA-115 with all options
DTC-305-CM	<i>XpressSim</i> channel-modelling option

DTA-145

Dual ASI/SDI Adapter

Features

- Two BNC ports: one dedicated ASI/SDI output port and one software-selectable ASI/SDI input- or second independent output port, with status LED
- All hardware and software features found in the market place, plus more
- Watchdog-controlled input-to-output relays for redundant configurations
- Support for genlock
- Cable equalisation and inverted ASI
- Bitrate measurement and statistics
- Flexible receive modes with time-stamping, packet-sequence counting and false-sync pass through for full TR 101 290 support
- Lossless SDI Huffman encoding / decoding
- Low profile or standard PCI bracket
- Free drivers and SDK (DTAPI) for Linux, Windows XP/2k3/Vista/2k8/7/8/10 and .NET

Applications

- ASI/SDI stream station
- High-availability ASI/SDI generation
- ASI/SDI analysis or monitoring
- Universal ASI/SDI input/output adapter for PC-based applications that record, play and/or process MPEG-2 transport streams and/or SDI digital video

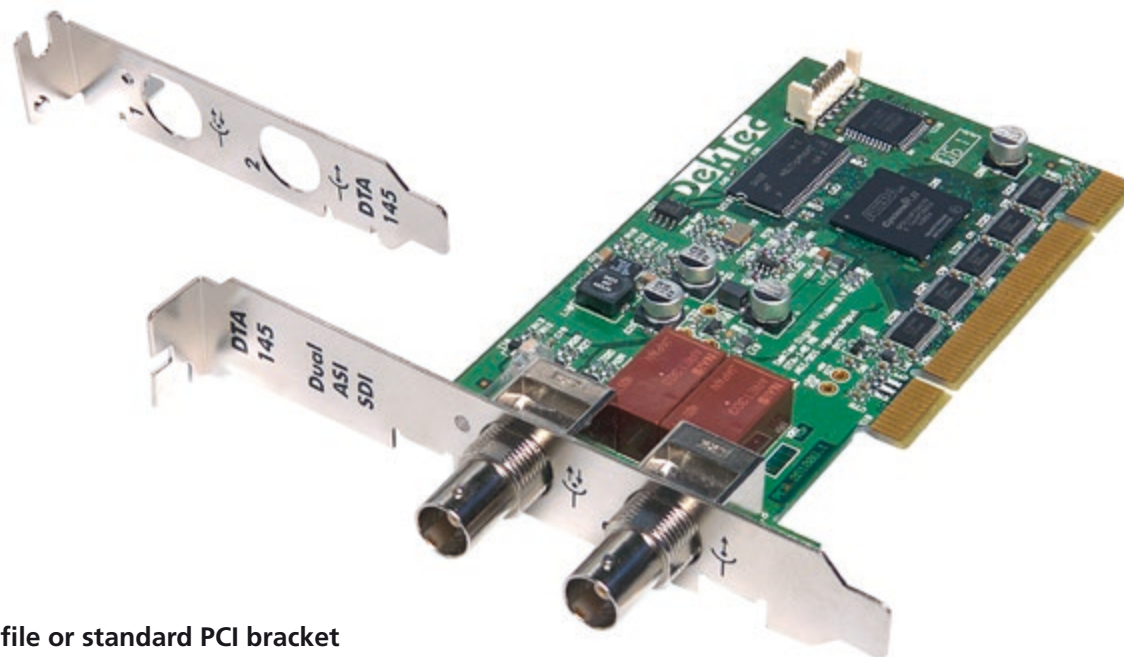

Low profile or standard PCI bracket
ASI/SDI input+output or dual output
Most complete feature set in the market

Key Attributes

Parameter	Value	
Connector	75-Ω BNC (2x*)	
Input return loss	>15dB	
Hardware buffering	16MB / channel	
ASI	Physical layer	DVB-ASI (coax) EN50083-9
	Bitrate range	0 to 214Mbit/s
	Packet size	188 or 204**
SDI	Physical layer	SMPTE 259M/C
	Bitrate	270Mbit/s
	#Bits	8 or 10 bit
PCI compliancy	r2.2, 32-bit, 33/66MHz	

* 1xoutput and 1xsoftware-selectable input or output

** Arbitrary packet size in raw mode

Related Products

Type	Description
DTA-2145	Dual ASI/SDI adapter for PCI Express

Ordering Information

Type	Description
DTA-145-SLP	Dual ASI/SDI I/O adapter for PCI Express with <i>StreamXpress</i> ® and <i>StreamXpert</i> ® Lite
DTA-145-SY-SLP	DTA-145-SLP with <i>SdEye</i>
DTA-145-SXP	DTA-145-SLP with <i>StreamXpert</i> ®
DTA-145-SY-SXP	DTA-145-SLP with <i>SdEye</i> and <i>StreamXpert</i> ®

DTA-160

Gigabit TS-over-IP and Triple ASI Ports

Features

- Transmission and reception of transport streams over IP networks, with transcoding between ASI and IP ports
- IP encapsulation in accordance with SMPTE 2022-1 and SMPTE 2022-2
- Zero-jitter playout of multiple TS-over-IP streams
- ASM and SSM multicast support
- Generation of two-dimensional FEC with programmable dimensions D and L and block-aligned FEC linearization
- Re-ordering and error correction of TS-over-IP streams
- Time stamping of incoming IP packets to enable TS-over-IP jitter analysis
- Uniform software access to ASI- and TS-over-IP ports with DTAPI
- PCI rev 2.2, 32 bit, 33 or 66 MHz bus
- Comes with NDIS network driver

Applications

- Contribution and primary distribution over IP
- Multipurpose ASI/TS-over-IP stream station
- Jitter measurements of TS-over-IP streams
- Tunnelling ASI streams over an IP network
- General-purpose ASI and TS-over-IP inputs and outputs for OEM applications

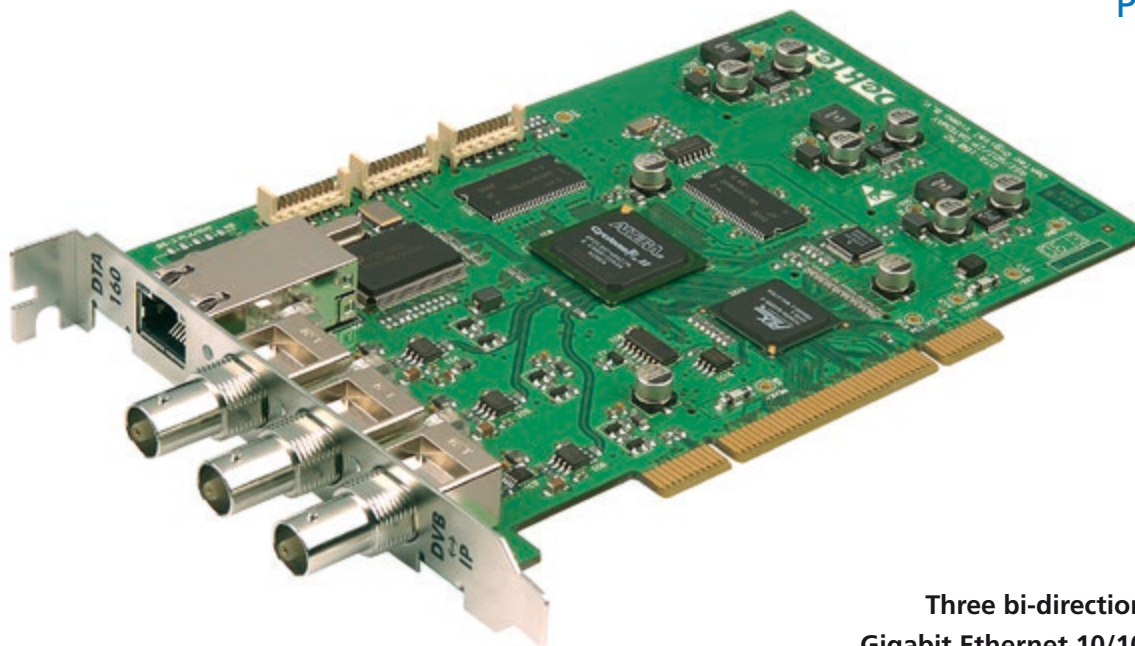

**Three bi-directional ASI ports
Gigabit Ethernet 10/100/1000 port
Transcoding between ASI and TS-over-IP**

Key Attributes

Parameter		Value
TS-over-IP	Physical layer	IEEE 802.3ab
	Data rate	10/100/1000
	Connector	RJ-45
	Maximum TS rate	600Mbit/s
	Parallel TS-over-IP streams	100+*
ASI	Physical layer	DVB-ASI (coax)
	Connector	75-Ω BNC (3x)
	Rx or Tx bitrate	0 to 214Mbit/s
	Resolution	<1bit/s
Transport packets per IP		1,2,3,4,5,6 or 7
Protocol		UDP or RTP
Transcoding rate		0 to 200Mbit/s
DVB ID		5821

* Limited only by cumulative TS rate and PC resources

Related Products

Type	Description
DTE-3100	Networked ASI output adapter
DTE-3120	Networked ASI input adapter

PC Requirements

Platform	Windows XP/2k3/Vista/2k8/7/8/10, Linux ≥2.6.18, 3.x, 4.x
Processor*	P4@2GHz, Core, Core 2, Core i7

* Or AMD equivalent

Ordering Information

Type	Description
DTA-160-SLP	Gigabit TS-over-IP and triple ASI adapter for PCI Bus with <i>StreamXpress®</i> and <i>StreamXpert® Lite</i>
DTA-160-J-SXP	DTA-160-SLP with <i>DtJitter</i> and <i>StreamXpert®</i>

DTU-215

USB-2 VHF/UHF Modulator

Features

- USB-2 based multi-standard modulator with support for most QAM-, OFDM- and VSB-based modulation standards
- Powered from the USB-2 bus, so no external power adapter is required
- Supports all constellations and modulation modes for each supported standard
- Digital upconversion for excellent signal quality without need for calibration
- Playout of I/Q sample files
- Programmable attenuator
- Free Windows and Linux SDK is fully compatible with other DekTec digital-video output adapters



No power adapter required
Fully agile from 36 to 1002MHz
Channel simulation option

Applications

- Multi-standard test generator
- Demonstrations
- Research and development

Key Attributes

Parameter	Value	
RF connector	75-Ω F male	
Frequency range	36 to 1002MHz ±3ppm	
Bandwidth (max)	8.0MHz	
I/Q sample rate	4.7 to 9.375MHz	
Level	Range	-46 to -15dBm (QAM) -49 to -18dBm (OFDM)
	Step size	0.5dB
	Accuracy	±2dB
MER	>40dB	
Adjacent channel		-54dB (QAM)
		-52dB (OFDM)
Phase noise	<-95dBc @ 10kHz	
Spectral purity	>50dB (47 to 1000MHz)	
USB port	USB-2	
Power (through USB-2)	5V, 500mA	
Dimensions (LxWxH)	123 x 62 x 22mm	

Modulation Standards

Modulation	Standard
ATSC VSB	ATSC A/53E
CMMB*	GY/T 220.1/2-2006
DAB+*	EN 300 401
DTMB*	GB 20600-2006
DVB-C	EN 300 429
DVB-C2*	EN 302 769
DVB-T / DVB-H	EN 300 744
DVB-T2*	EN 302 755
I/Q*	Arbitrary I/Q samples
ISDB-T*	ARIB STD-B31
QAM	J.83 Annex A/B/C

Ordering Information

Type	Description
DTU-215-SP	USB-2 VHF/UHF modulator with <i>StreamXpress</i> ®
DTU-215-GOLD	DTU-215 with all options

DTU-236A

8-VSB/QAM RF Probe with ASI Input for USB-2

USB-2 Adapters

Features

- Light-weight, easy-to-use RF adapter for tuning to any UHF/VHF or cable channel in the 45 to 1002MHz range
- Support for all QAM variants
- Extra input for Transport Streams on ASI
- Capture TS signals directly to file on a laptop PC for easy field recording
- Ruggedized portable unit that requires no additional power supply or batteries, operates entirely from a USB-2 connection
- Sensitive front-end allowing reception of RF signals from -30 to +50dBmV
- Combine DTU-236A with RFXpert software for RF measurements, *StreamXpert*® for real-time Transport-Stream analysis
- Channel plans for world-wide regions

RFXpert Measurements

- RF Level, MER, EVM, Constellation, Eye
- BER: Pre/Post FEC, SER (Severe Errored), Errored Seconds
- Channel, Adjacent and Full Spectrum



Receives any UHF/VHF or cable channel
Additional ASI Transport-Stream input
No power supply or batteries required

Key Attributes

Parameter	Value	
RF	Connector	75-Ω "F" female
	Frequency range	45 to 1002MHz
	Bandwidth	6/7/8MHz
	Level measurement	-30 to +50dBmV
	Level accuracy	±2dB
	MER range	15 to 38dB
ASI	Connector	75-Ω BNC
	Standard	EN50083-9
	Bit rate	0.5 to 100Mbit/s
Dimensions in mm (LxWxH)		180x107x36
Weight		< 500g

Related Products

Type	Description
DTC-320-SX	<i>StreamXpert</i> ® transport-stream analyzer
DTC-340-RX	RFXpert RF measurement and monitoring software

Ordering Information

Type	Description
DTU-236A-SL	8-VSB / QAM-A/B/C RF probe with <i>StreamXpert</i> ® Lite
DTU-236A-RX	DTU-236A-SL with <i>RFXpert</i>
DTU-236A-SX	DTU-236A with <i>StreamXpert</i> ®
DTU-236A-RSX	DTU-236A with <i>RFXpert</i> and <i>StreamXpert</i> ®

DTU-238

DVB-T2/T/C, ISDB-T and ASI Probe for USB-2

USB-2 Adapters

Features

- Light-weight, RF adapter for tuning to any UHF/VHF or cable channel in the 42 to 1002MHz range
- Receiver for DVB-T2, DVB-T and DVB-C
- Extra input for Transport Streams on ASI
- Capture TS signals directly to file on a laptop PC for easy field recording
- Ruggedized portable unit that requires no additional power supply or batteries, operates entirely from a USB-2 connection
- Sensitive front-end allowing reception of RF signals from -40 to +50dBmV
- Combine DTU-238 with RFXpert software for RF measurements, *StreamXpert*® for real-time Transport-Stream analysis
- Channel plans for world-wide regions

RFXpert Measurements

- RF Level, MER, EVM, Constellation, Eye
- BER: Pre/Post FEC, PER (Packet Error Rate), Errored seconds
- Channel, Adjacent and Full Spectrum



DVB-T2, DVB-T and DVB-C reception
Additional ASI Transport-Stream input
No power supply or batteries required

Key Attributes

Parameter		Value
RF	Connector	75-Ω "F" female
	Frequency range	42 to 1002MHz
	Bandwidth	5/6/7/8/10MHz
	Input sensitivity	-40 to +50dBmV
	Input return loss	8dB
	MER range	15 to 38dB
ASI	Connector	75-Ω BNC
	Standard	EN50083-9
	Bit rate	0.5 to 100Mbit/s
Dimensions in mm (LxWxH)		180x107x36
Weight		< 500g

Related Products

Type	Description
DTC-320-SX	<i>StreamXpert</i> ® transport-stream analyzer
DTC-340-RX	RFXpert RF measurement and monitoring software

Ordering Information

Type	Description
DTU-238-SL	DVB-T/T2, DVB-C and ASI probe for USB-2 with <i>StreamXpert</i> ® Lite
DTU-238-RX	DTU-238-SL with <i>RFXpert</i>
DTU-238-SX	DTU-238 with <i>StreamXpert</i> ®
DTU-238-RSX	DTU-238 with <i>RFXpert</i> and <i>StreamXpert</i> ®

DTU-245

FantASI USB-2 ASI/SDI Input+Output Adapter

Features

- Convenient, compact USB adapter that can be used to capture and generate MPEG-2 transport streams (ASI) and uncompressed serial digital video (SDI)
- USB powered - no power supply required
- Independent operation of input and output:
 - Full-duplex: maximum combined bitrate of 160Mbit/s
 - Half-duplex: Full DVB-ASI and SDI bitrate range
- 16-Mbytes local hardware buffer for sustained real-time streaming

Applications

- General-purpose USB adapter for capturing, generating and processing of ASI and SDI streams
- On-site recording and analysis
- Portable demo set

Bundled Software (DTU-245-SXP)

- *StreamXpert*[®] transport-stream analyzer
- *StreamXpress*[®] ASI / SDI player
- Windows/Linux drivers and associated SDK for developing custom applications



No AC power adapter required
Portable streaming of DVB-ASI and SDI
Essential tool for every digital-TV engineer

Key Attributes

Parameter	Value	
Connector	75-Ω BNC (2x)	
ASI	Physical layer	EN50083-9
	Bitrate range	0 to 160Mbit/s*
	Packet size	188 or 204
SDI	Physical layer	SMPTE 259M/C
	Bitrate (half-duplex only)	270Mbit/s
	#Bits	8 or 10 bit
USB port	USB-2**	
Power (through USB-2)	5V, 400mA max	
Dimensions in mm (LxWxH)	87 x 104 x 30	

* Maximum total bitrate (Input+Output) in full-duplex mode.

In half-duplex mode the full ASI/SDI range is supported

** USB-1 provides insufficient bandwidth and is not supported

Ordering Information

Type	Description
DTU-245-SLP	USB-2 ASI/SDI input+output adapter with <i>StreamXpress</i> [®] and <i>StreamXpert</i> [®] Lite
DTU-245-SXP	DTU-245-SLP with <i>StreamXpert</i> [®]
DTU-245-SY-SLP	DTU-245-SLP with <i>SdEye</i>
DTU-245-SY-SXP	DTU-245-SLP with <i>SdEye</i> and <i>StreamXpert</i> [®]
DTU-245-DVB+	DTU-245-SLP with <i>DVBAnalyzer</i> advanced transport-stream analyser

DTU-315

All-Standard All-Band Modulator for USB-3

Features

- Pocket-size modulator for satellite, cable and terrestrial standards
- Fully agile from 36 to 2150MHz, covering VHF, UHF and L-band
- Modulation bandwidth up to 70MHz
- Excellent signal quality
- Single USB cable to the DTU-315 supplies power, data and control
- Supports all constellations and modulation modes for each supported standard
- Digital channel simulator option including multipath echo and AWGN
- F and BNC cable assemblies included
- Use with DekTec's *StreamXpress*® for easy generation of RF test signals
- Free Windows and Linux SDK (DTAPI) for writing your own applications

Applications

- RF test generator in your R&D lab or factory for developing, qualifying or repairing any equipment with a DTV antenna input
- Portable demo set for TV receivers, easy to carry to customer demos, trade shows, etc.
- TV transmission or distribution using modulated signals in shops, hotels, hospitals etc.

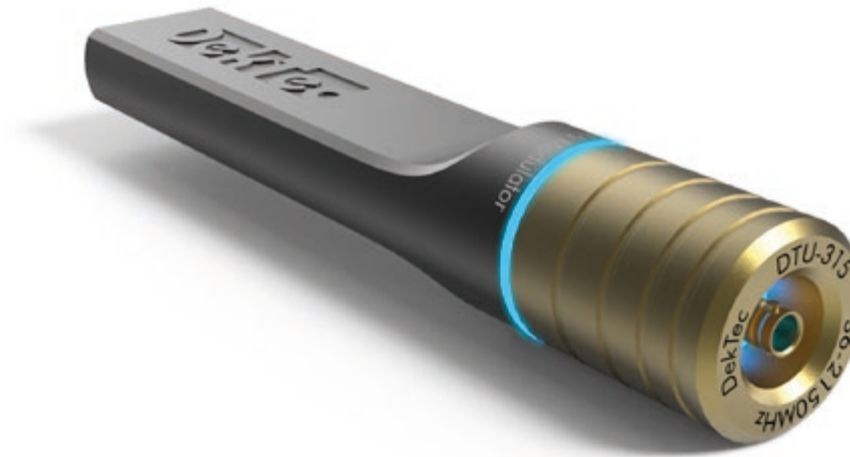

Key Attributes

Parameter	Value
RF connector	75-Ω micro-BNC female
Frequency range	36 to 2150MHz
Bandwidth (max)	70MHz
I/Q sample rate	0.08 to 70Msps
RF level	Range* -45 to -25dBm
	Step size 0.5dB
MER (typical)	>40dB
Phase noise	<-105dBc @ 10kHz
Spectral purity	>50dB
USB port	USB-3**
OS	Windows 7/8/10
	Linux 3.x, 4.x

* For OFDM standards: up to 1GHz; for single-carrier standards up to 2GHz; above 2GHz the output level is max. 5dB lower.

** Must be a real USB-3 port; the DTU-315 will not operate with USB-2.

Modulator for all popular DTV standards
Fully agile over VHF, UHF and L-band
USB cable supplies power, data and control

Modulation Standards

Standards
ADTB-T*, ATSC, ATSC-M/H*, ATSC 3.0*, CMMB*, DAB(+)*, DMB-T/H*, DVB-C, DVB-C2*, DVB-S, DVB-S2, DVB-S2X*, DVB-T, DVB-T2*, I/Q samples*, ISDB-S*, ISDB-T*, ISDB-Tmm*, QAM-B, QAM-C, T-DMB*

* Option

Ordering Information

Type	Description
DTU-315-SP	All-standard all-band modulator for USB-3 with <i>StreamXpress</i> ® player/test-generator software
DTU-315-GOLD	DTU-315 including all current and future modulation options
DTR-315-RACK	1U 19"-rack mounting kit for holding up to 8x DTU 315

DTU-350, DTU-351

HD-SDI Output for USB-3, HD-SDI Input for USB-3

DTU-350 HD-SDI OUT – FEATURES

- General purpose HD-SDI output for USB-3
- All 10-bit samples in the full SDI frame can be generated
- Supported by Matrix API to automatically build frames from HANC, VANC and video
- All 16 audio channels can be generated

Applications

- With *StreamXpress*®: HD-SDI test generator
- HD-SDI output of software video decoder
- HD-SDI output of your custom application

DTU-351 HD-SDI IN – FEATURES

- General purpose HD-SDI input for USB-3
- All 10-bit samples from the full SDI frame can be read
- Supported by Matrix API to automatically separate HANC, VANC and video
- Scaling by 1/4 or 1/16 in hardware

Applications

- With *SdEye*: HD-SDI waveform analysis
- HD-SDI input for software video encoder



HD-SDI interfaces with full frame access
Hardware scaling to reduce USB bandwidth
Support for SD-SDI

Key Attributes

Parameter	Value
Physical layer	SD-SDI: SMPTE 259M HD-SDI: SMPTE 292M
Connector	75-Ω BNC
Return loss	≥12dB @ 0 to 1.5GHz
Matrix API features	8/10/16-bit conversion Audio/Video/ANC extraction Hardware scaling by 1/4 or 1/16 Multiple unit synchronization
USB port	USB-3
SDK	DTAPI, Matrix API DirectShow filter
OS	Windows 7/8/10; Linux 3.x, 4.x

Supported Formats

Formats
525i59.94, 625i50
720p23.98, 720p24, 720p25, 720p29.97, 720p30, 720p50, 720p59.94, 720p60
1080p(sf)23.98, 1080p(sf)24, 1080p(sf)25, 1080p(sf)29.97, 1080p(sf)30, 1080i50, 1080i59.94, 1080i60

Ordering Information

Type	Description
DTU-350-SP	HD-SDI output for USB-3 with <i>StreamXpress</i> ®
DTU-351-SL-SY	HD-SDI input for USB-3 with <i>SdEye</i> , <i>StreamXpert</i> ® Lite

DTE-3100

Networked DVB-ASI Output Adapter

Features

- Standalone module can either be used as compact autonomous TS-over-IP to ASI gateway, or as remote I/O device for PC-based applications
- SMPTE-2022 and DTAPI mode
- Power over Ethernet (PoE) support: No separate power feed required
- External power supply available for use with non-PoE enabled switch
- Advanced time-reconstruction algorithm to overcome IP jitter, with programmable size of jitter-tolerance buffer
- Supports IP decapsulation and 2D FEC decoding according to SMPTE 2022-1 and SMPTE 2022-2
- LCD status display shows device identifier, bitrate, IP/MAC address and status
- Uniform software access to DekTec TS-over-IP-, PCI- and USB devices through DTAPI
- Install up to 12 modules in 3U 19" rack space using the DekTec rack-mountable rail
- Units can be mounted directly on a wall using a DIN rail

Applications

- Autonomous TS-over-IP to DVB-ASI gateway
- With DTE-3120: Tunnelling of ASI signals over LAN, WAN or the Internet
- Remote DVB-ASI output adapter for server-based data inserters, stream servers, multiplexers and similar systems



TS-over-IP to DVB-ASI converter
Power over Ethernet enabled
UDP, RTP, 2D FEC (SMPTE-2022)

Key Attributes

Parameter	Value	
GigE port	Physical layer	IEEE 802.3af
	Data rate	10/100/1000
	Connector	RJ-45
ASI port	Physical layer	DVB-ASI (coax)
	Connector	75-Ω BNC (2x)
	Tx bitrate	0 to 214Mbit/s*
	Resolution	<1bit/s
Transport	TP per IP	1 to 7
	Encapsulation	UDP or RTP
	FEC	SMPTE 2022
TS-over-IP to ASI latency	10ms	
Jitter tolerance range	1 to 120 ms	
DVB ID	5824	

* 209Mbit/s in SMPTE mode

Control

IP-address assignment	DHCP or static
Multicast support	IGMP v2
Device management	Browser based
Network management	SNMP v2c
Discovery	WS-Discovery

Related Products

Type	Description
DTE-3120	Networked ASI input adapter

Ordering Information

Type	Description
DTE-3100	Networked ASI output adapter
DTE-3100-SP	DTE-3100 with <i>StreamXpress</i> ®

Units are shipped with power supply. Add -NOPSU for ordering without power supply

DTE-3114

Networked Quad QAM Modulator

Features

- Standalone four-channel QAM modulator with TS-over-IP inputs and directly synthesized VHF/UHF outputs
- 2D FEC decoder for error correction of incoming TS-over-IP streams
- Web and SNMP interface for setting parameters and observing status
- Unit can be powered via the Ethernet cable (Power over Ethernet) or through a DC power supply jack
- Advanced removal of IP jitter with programmable size of jitter-tolerance buffer
- Full support of SMPTE 2022-1/2
- LCD status display shows device identifier, QAM-mode, carrier frequencies, output level and IP/MAC address
- Install up to 12 modules in 3U 19" rack space using DekTec rack-mountable rail



**Four QAM-A/B/C modulators
Agile over VHF/UHF up to 1GHz
RTP with FEC decoding on each channel**

Applications

- Cable-TV modulator with TS-over-IP input
- QAM test generator

Key Attributes

Parameter		Value
Main RF port	Connector	75-Ω F Female
	Output level (total)	-32 to -9dBm
Monitor port	Connector	75-Ω F Female
	Output level (total)	-33±3dBm
RF	Range	36 to 1002MHz
	Channel spacing	6 to 8MHz
	Symbol rate	4.48 to 7.0MBd
	MER	42dB
GigE port	Physical layer	IEEE 802.3af
	Connector	RJ-45
Transport	TP per IP	1 to 7
	Encapsulation/FEC	SMPTE 2022
TS-over-IP to QAM latency		10ms (max)
Jitter tolerance range		1 to 120 ms

Modulation

QAM-A	EN 300 429 (DVB-C)
QAM-B	J.83 Annex B with support for all interleaver modes
QAM-C	J.83 Annex C

Control

IP-address assignment	DHCP or static
Multicast support	IGMP v2
Device management	Browser based
Network management	SNMP v2c
Discovery	WS-Discovery

Ordering Information

Type	Description
DTE-3114	Networked quad QAM modulator

Units are shipped with power supply. Add -NOPSU for ordering without power supply

DTE-3120

Networked DVB-ASI Input Adapter

Features

- Standalone module can either be used as compact autonomous ASI to TS-over-IP gateway, or as remote I/O device for PC-based applications
- SMPTE-2022 and DTAPI mode
- Time stamping for monitoring applications
- Power over Ethernet (PoE) support: No separate power feed required
- External power supply available for use with a non-PoE enabled switch
- Fail-over relays for input-to-output connection in case of power failure
- Supports IP encapsulation and 2D FEC encoding according to SMPTE 2022-1 and SMPTE 2022-2
- LCD status display shows device identifier, bitrate, IP/MAC address and status
- Uniform software access to DekTec TS-over-IP-, PCI- and USB devices through DTAPI
- Install up to 12 modules in 3U 19" rack space using the DekTec rack-mountable rail
- Units can be mounted directly on a wall using a DIN rail

Applications

- Autonomous DVB-ASI to TS-over-IP gateway
- With DTE-3100: Tunnelling of ASI signals over LAN, WAN or the Internet
- Remote DVB-ASI input adapter for server-based analysers, monitoring applications (Xpect®), multiplexers and similar systems



DVB-ASI to TS-over-IP converter
Power over Ethernet enabled
UDP, RTP, 2D FEC (SMPTE-2022)

Key Attributes

Parameter	Value	
GigE port	Physical layer	IEEE 802.3af
	Data rate	10/100/1000
	Connector	RJ-45
ASI port	Physical layer	DVB-ASI (coax)
	Connector	75-Ω BNC (2x)
	Rx bitrate	0 to 214Mbit/s
	Return loss	17dB typ.
Transport	TP per IP	1 to 7
	Encapsulation	UDP or RTP
	FEC	SMPTE 2022
ASI to TS-over-IP latency	10ms	
Buffer size	32MB	
DVB ID	5823	

Control

IP-address assignment	DHCP or static
Multicast support	IGMP v2
Device management	Browser based
Network management	SNMP v2c
Discovery	WS-Discovery

Related Products

Type	Description
DTE-3100	Networked ASI output adapter

Ordering Information

Type	Description
DTE-3120	Networked ASI input adapter
DTE-3120-SL	DTE-3120 with <i>StreamXpert® Lite</i>
DTE-3120-SX	DTE-3120-SL with <i>StreamXpert®</i>

Units are shipped with power supply. Add -NOPSU for ordering without power supply

DTE-3137

Networked DVB-S(2) Satellite Receiver

Features

- Standalone DVB-S2 receiver supporting QPSK, 8PSK, 16APSK and 32APSK
- DVB-S2 demodulation compliant to EN302-307 and EN301-210, as well as legacy DVB-S support
- Web and SNMP interface for setting parameters and observing status
- Unit can be powered via the Ethernet cable (Power over Ethernet) or through a DC power supply jack
- LNB power insertion
- Full support of SMPTE 2022-1/2, with 2D FEC encoder for robust transport over IP
- LCD status display shows device identifier, mode, carrier frequency, level, SNR, BER and IP/MAC address
- Install up to 12 modules in 3U 19" rack space using DekTec rack-mountable rail

Applications

- SMATV: Redistribution of satellite TV
- General-purpose receiver for obtaining the full Transport Stream from a DVB-S2 signal



Compact professional satellite receiver
Full TS output on IP and DVB-ASI
LNB power insertion

Key Attributes

Parameter	Value	
RF input	Connector	75-Ω F Female
	Return loss	>10dB
	Tuning range	950 to 2150MHz
	Sensitivity	-30 to -60dBm
	Baud rate	2 to 40MBd
LNB	Supply	13V/18V 400mA
	22kHz tone	On/Off
TS output	Connector	75-Ω BNC
	DVB-ASI	EN50083-9
GigE port	Connector	RJ-45
	Physical layer	IEEE 802.3at
Transport	TP per IP	1 to 7; UDP/RTP
	FEC	SMPTE 2022-1
Device power	Connector	2.1 mm DC plug
	24V Supply	22 to 30V; 17W

Standards

Standard	Mode
EN 301 210	DVB-S
EN 302 307	DVB-S2: QPSK, 8-/16-/32APSK CCM only

Control

IP-address assignment	DHCP or static
Multicast support	IGMP v2
Device management	Browser based
Network management	SNMP v2c
Discovery	WS-Discovery

Ordering Information

Type	Description
DTE-3137	Networked DVB-S(2) receiver

DTE-RCK1

19" Mountable Rack for DTE-31XX

- Mount up to 12 DTE-31XX units in a 19" rack
- Mount another 12 units at the back side



DTE-STAND

Table Stand for DTE-31XX

- For non-wall mount applications



DTM-3200

OEM Module TS-over-IP Converter

Features

- Compact OEM module for interfacing a Transport Stream to a network. The DTM-3200 converts from IP to ASI, or from ASI to IP
- Additional 8-bit parallel Transport Stream I/O port on a 26-way boxed header
- Advanced time-reconstruction algorithm to overcome IP jitter, with programmable size of jitter-tolerance buffer
- Full supports of IP encapsulation and 2D FEC encoding/decoding as described in SMPTE 2022-1/2
- Unicast and multicast IP addressing
- Various serial interfaces available for controlling the OEM module
- Persistent storage of configuration parameters

Applications

- Easy way to add a TS-over-IP input or output to your TS-processing product
- Tunnelling of ASI signals over LAN, WAN or the Internet

Development Kit

- DTM-3200 module
- Power supply with cable
- USB to serial converter

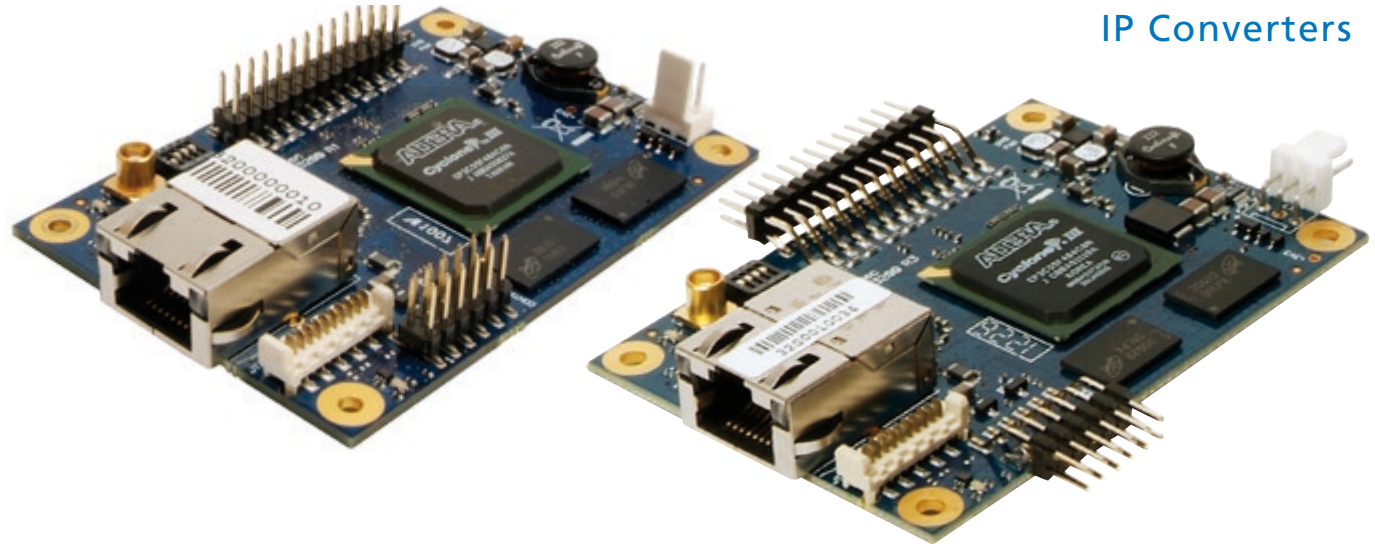

Converts ASI to IP or IP to ASI
Serial and parallel TS port
UDP, RTP, 2D FEC (SMPTE-2022)

Key Attributes

Parameter		Value
GigE port	Physical layer	IEEE 802.3a
	Data rate	100/1000
	Connector	RJ-45 with LEDs
DVB-ASI port	Physical layer	EN50083-9
	Connector	1x 75-Ω MCX
	Tx bitrate	0.01 to 214Mbit/s
Parallel port	Physical layer	M-LVDS
	Signals	Clock, sync, valid, 8-bit data
	Connector	26-way header
Transport	TP per IP	1 to 7
	Encapsulation	UDP or RTP
	FEC	SMPTE 2022
TS-over-IP to ASI latency*		1ms
Jitter tolerance range		1 to 500ms
Dimensions WxHxD		80x55x14mm

* Excluding FEC reconstruction and jitter tolerance delay.

IP Protocol Support

Encapsulation	IEEE 802.2 SNAP, Eth. II
IP support	IPv4
IP-address assignment	DHCP, link local or static
Multicast support	IGMP v2
Device management	Out of band: RS-232, RS-422, RS-485, I2C
Network management	Not supported

Related Products

Type	Description
DTE-3100	Networked ASI output (DIN-rail mount)
DTE-3120	Networked ASI input (DIN-rail mount)

Ordering Information

Type	Description
DTM-3200	OEM TS-over-IP converter
DTM-3200RA	DTM-3200 with right-angle connectors
DTM-3200-DEVKIT	Development kit for DTM-3200

DTM-3224

Standalone OEM Module Quad ASI to IP Converter

Features

- Compact OEM module for interfacing four ASI transport streams to an IP network
- Encoding and insertion of 2D FEC packets as defined in SMPTE 2022-1
- IP encapsulation with UDP and RTP support according to SMPTE 2022 2
- Unicast and multicast IP addressing
- IPv4 or IPv6
- Supports source-specific multicast
- Choice of three serial control interfaces:
USB 2.0, true RS-232 or I2C
- Persistent storage of configuration parameters in on-board flash memory
- Mounting compatible to DTM-3200

Applications

- Tunnelling of ASI transport streams over LAN, WAN or the Internet



Quad ASI to Gigabit Ethernet conversion
Serial control over USB, I²C or RS-232
UDP, RTP, 2D FEC (SMPTE-2022)

Key Attributes

Parameter		Value
GigE port	Physical layer	IEEE 802.3a
	Data rate	100/1000
	Connector	RJ-45 with LEDs
ASI ports	Number of ports	4
	Physical layer	EN50083-9
	Connector	4x 75-Ω MCX
	Bitrate per port	0.01 to 214Mbit/s
	Max. total bitrate	700Mbit/s
Transport	TP per IP	1 to 7
	Encapsulation	SMPTE 2022-2
	FEC	SMPTE 2022-1 up to 20x20
Power supply requirement		12V±10%
Dimensions WxHxD		80x55x14mm

PROTOCOL SUPPORT

Ethernet encapsulation	IEEE 802.2 SNAP, Eth. II
IP support	IPv4, IPv6
IP-address assignment	DHCP, DHCPv6, link local or static
Multicast support	IGMP v3, MLDv2
Device management	Out of band: RS-232, USB 2.0, I2C
Network management	Not supported

Ordering Information

Type	Description
DTM-3224	OEM Quad ASI to IP converter
DTM-3224-DEVKIT	Development kit for DTM-3224

DTM-3237

OEM DVB-S2 Receiver with DVB-ASI Output

Features

- Compact OEM module for receiving DVB-S2 or DVB-S and outputting it as DVB-ASI
- All DVB-S2 modulation types can be demodulated: QPSK, 8PSK, 16/32APSK
- Supports advanced DVB-S2 features including VCM, ACM, Multiple Input Streams (MIS) and Generic Stream (GS)
- Reception and forwarding of transport streams or baseband frames (BBFRAMES)
- Full LNB support with DiSEqC interface and 13V/14V/18V/19V 400mA supply
- Signal quality indicators include lock status, RF level, modulation type, code rate, BER, MER
- Serial control of the OEM module through USB, I2C or LVTTTL RS-232
- Persistent storage of configuration parameters



Converts DVB-S2 to DVB-ASI
Compact and low-cost OEM module
Supports 32APSK, MIS, GS, VCM, ACM

Applications

- Low-cost receiver module for satellite to cable transcoders
- Satellite data distribution
- Monitoring of satellite signal quality
- In combination with DTM-3200: DVB-S2 (or DVB-S) to TS-over-IP conversion

Key Attributes

Parameter	Value	
Antenna input	75-Ω MCX Female	
Input return loss	>9dB @ 1 to 2GHz	
Tuning range	950 to 2150MHz	
Input sensitivity	-60 to -30dBm	
Baud rate	2 to 45MBd	
Modulation standard	DVB-S2, DVB-S	
Metrology	RF level	-60 to -30dBm ±5dB
	MER	0 to 22dB ±2dB
	BER (DVB-S)	Pre Viterbi; Pre RS
	BER (DVB-S2)	Post BCH; Post LDPC
LNB supply	13V/14V/18V/19V 400mA	
DVB-ASI port	Physical layer	EN50083-9
	Connector	75-Ω MCX Female

Related Products

Type	Description
DTM-3200	OEM module for conversion between ASI and TS-over-IP
DTA-2107	DVB-S/DVB-S2 modulator with L-band upconverter for PCIe
DTA-2137C	DVB-S/S2 receiver for PCIe
DTE-3137	Standalone DVB-S/S2 receiver with ASI and TS-over-IP output

Ordering Information

Type	Description
DTM-3237	OEM DVB-S2 receiver with DVB-ASI output
DTM-3237-DEVKIT	Development kit for DTM-3237

DTC-300 StreamXpress®

Transport-Stream/SDI Payout Software

Features

- Integrate yourself a low-cost, high-performance stream player using a standard- or industrial PC, a DekTec output adapter and the *StreamXpress*® playout software
- Integrated (P)SI viewer
- Control of modulation parameters
- Optional channel modeling of RF output signal
- Integrated ISDB-T hierarchical multiplexer
- Supports DTA-Plus RF attenuator
- Play-out at a higher rate by null-packet stuffing with PCR correction
- Endless play with optional automatic correction of continuity-counter and PCR/PTS/DTS fields
- Automatic computation of transport rate
- Reproducible injection of errors in the transport stream with adjustable error rate
- SOAP-based remote control option

Applications

- Universal MPEG-2 stream generator for feeding set-top boxes, digital-video processing equipment, etc.
- Demoiing your MPEG-2 equipment
- Laboratory MPEG-2 test-signal generator

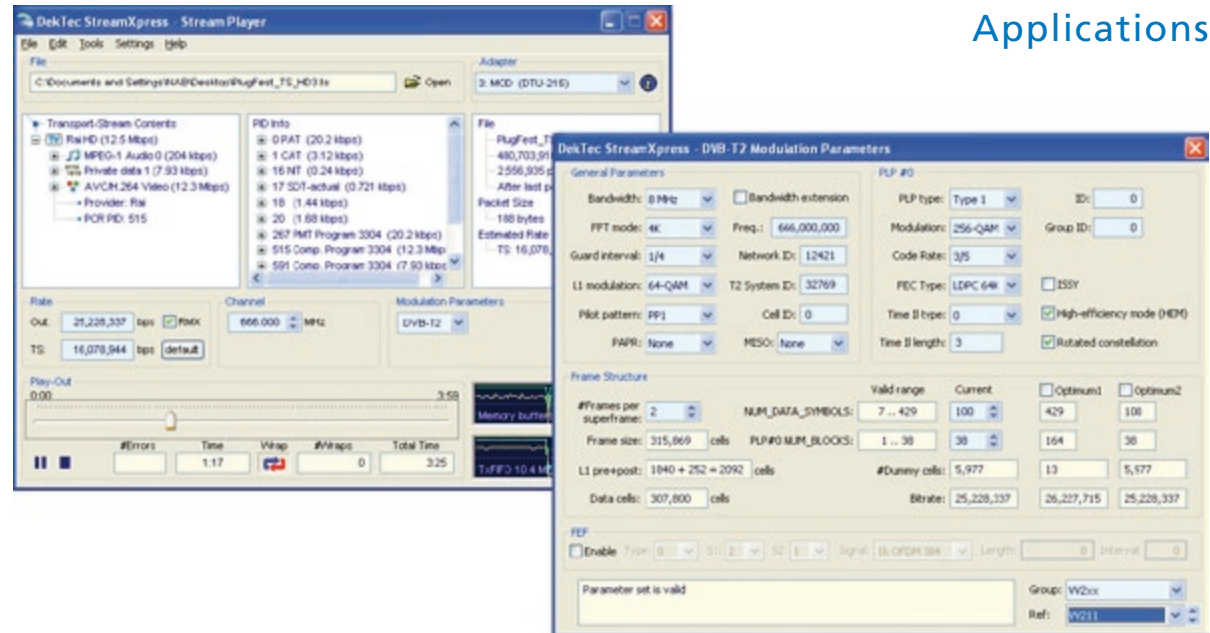

Industry-standard player
Selective error injection
Integrated (P)SI viewer, looping

Supported Output Adapters

Signal Type	Supported Adapters
DVB-ASI	DTA-105, 112, 115, 145, 160, 2136, 2137C, 2142, 2144B, 2145, 2152, 2154, 2160, 2174, 2179, 2195, DTE-3100, DTU-205, 245
DVB-SPI	DTA-102, 2142
HD-SDI	DTA-2152, 2154, 2174, 2179, 2195, DTU-350
3G-SDI	DTA-2174, 2179, 2195
Modulators	DTA-107, 110, 111, 112, 115, 116, 117, 2107, 2111, 2115B, DTU-215, 315
TS-over-IP	DTA-160, 2160, 2162, Local NIC

PC Requirements

Platform	Windows XP/2k3/Vista/2k8/7/8/10
Processor*	PIII (ASI) to Core 2/Core i7 (DVB-T2)

* Or equivalent AMD processor

Ordering Information

Type	Description
DTC-300-SP	<i>StreamXpress</i> ® playout software
DTC-300-DGL	<i>StreamXpress</i> ® license on a USB dongle for local NIC playout
DTC-302-RC	Remote control option
DTC-305-CM	<i>XpressSim</i> channel-modelling option for modulators

DTC-320 StreamXpert® v2

Transport-Stream Analyser Software

Features

- Real-time analysis, monitoring and recording of MPEG-2 transport streams
- Provides detailed statistics on PIDs, services and tables found in the transport stream
- Deep decoding of PSI, DVB-SI, DVB-RCS and ATSC-PSIP tables and descriptors
- User-definable TR 101 290 templates
- Integrated video decoder for MPEG-2 video, AVC/H.264, AVS and HEVC/H.265, with support for 4:2:2 and 10-bit video
- Integrated audio decoder with support for MPEG-1 layer II, (HE-)AAC, AC3 and AC4
- Analysis of TS-over-IP streams via a DTA-160, DTA-2160, DTA-2162 or a local network adapter
- Decoding and display of closed captions
- The world's most cost-effective and user-friendly MPEG-2 transport-stream analyser

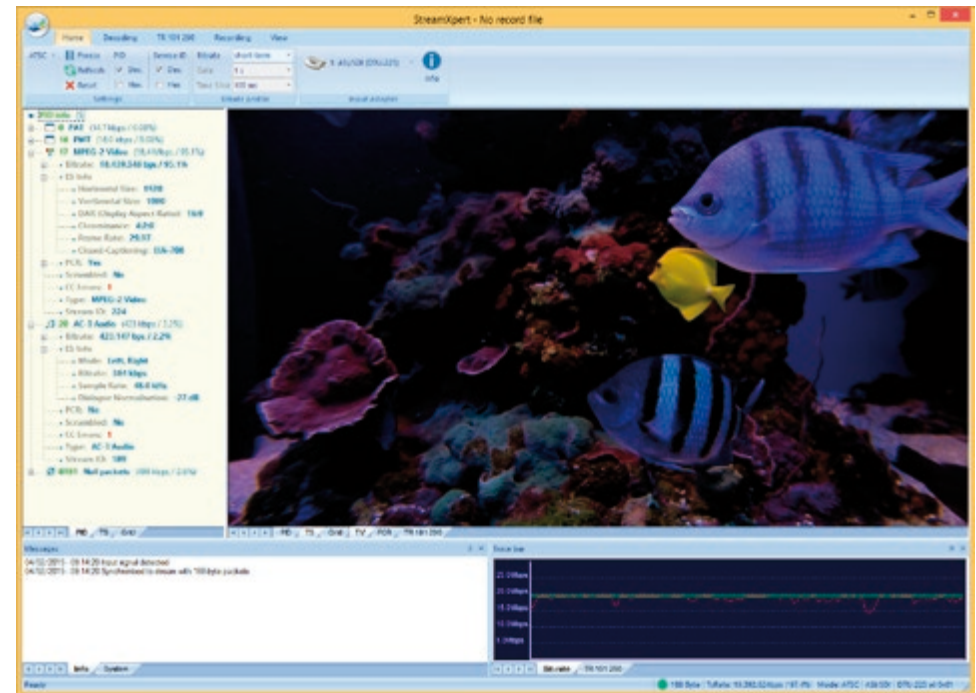

Applications

- Test and validation of equipment with transport-stream output, e.g. multiplexers
- Quality monitoring of MPEG-2 transport streams in studios, head ends, etc.

Supported Input Adapters

Signal Type	Supported Adapters
DVB-ASI	DTA-112, 115, 116, 117, 124, 145, 160, 2142, 2144B, 2145, 2152, 2154, 2160, 2174 DTE-3120, DTU-225, 245
DVB-SPI	DTA-122, 2142
Receivers	DTA-2131, 2136, 2137C, 2138B, 2139 DTU-236A, 238, DTE-3137
TS-over-IP	DTA-160, 2160, 2162, PC NIC

PC Requirements

Platform	Windows XP/2k3/Vista/2k8/7/8/10
Processor*	Core i5 (HD-AVC decoding)

* Or equivalent AMD processor

Related Products

Type	Description
DTC-335-SY	SdEye SDI analysis software
DTC-720	Xpect® transport-stream monitoring

Ordering Information

Type	Description
DTC-320-SX	StreamXpert® transport stream analyzer
DTC-320-NIC	StreamXpert® for PC NIC (dongle)
DTC-320-SXDGL	StreamXpert® license on a USB dongle
DTC-321-SL	StreamXpert® Lite (-SL option)
DTC-3201-1YR	1 year software maintenance for StreamXpert® v2

DTC-335 SdEye

Real-Time SDI Waveform Monitor

General Features

- Real-time waveform analyser for SD- and HD-SDI signals
- Contemporary GUI with quick access buttons
- Support for .dtsdi file input
- EDH/CRC error detection
- Stream out to SDI for monitoring
- SDI data logging to a CSV log file

Picture Display

- Top, bottom, interlaced, full frame
- Separate Y, Cb, Cr or RGB channel display

Waveforms

- Y,Cb,Cr or RGB graphs
- Vectorscope
- Single line selection

Audio

- Audio decoding/display
- Peak meter (up to 16-channel display)
- Stereoscope

SDI Ancillary Data

- List of all ancillary data streams
- Display of SDI data words with user selectable row and column
- Hex or decimal, 8 or 10-bit display



Key Attributes

Parameter	Value
Input signal	SD-SDI: SMPTE 259M HD-SDI: SMPTE 292M 3G-SDI: SMPTE 424M

PC Requirements

Platform	Windows XP/2k3/Vista/2k8/7/8/10
Processor*	P4@3.0Ghz Core 2, Core i7

* Or equivalent AMD processor

Supported Input Adapters

Bus	Supported Adapters
PCI	DTA-124, 145, 160
PCI Express	DTA-2144B, 2145, 2152, 2154 DTA-2160, 2174
USB	DTU-225, 245, 351

Ordering Information

Type	Description
DTC-335-SY	SdEye SDI Waveform Monitor

Features

- Real-time application for demodulating DVB-T2, displaying signalling information and outputting a demodulated Transport Stream on UDP
- T2-Lite support
- Uses DTA-2131
- Measures RF level, C/N and MER
- Gathers statistics about number of LDPC iterations required to correct all errors and displays LDPC iterations history in a graph
- Shows Constellation per PLP or Subcarrier, Impulse Response, MER per PLP and Transfer function graphs
- T2-MI output on UDP for obtaining all PLPs in parallel

Applications

- Measurements and analysis of DVB-T2 signals
- DVB-T2 demonstrations
- DVB-T2 field trials

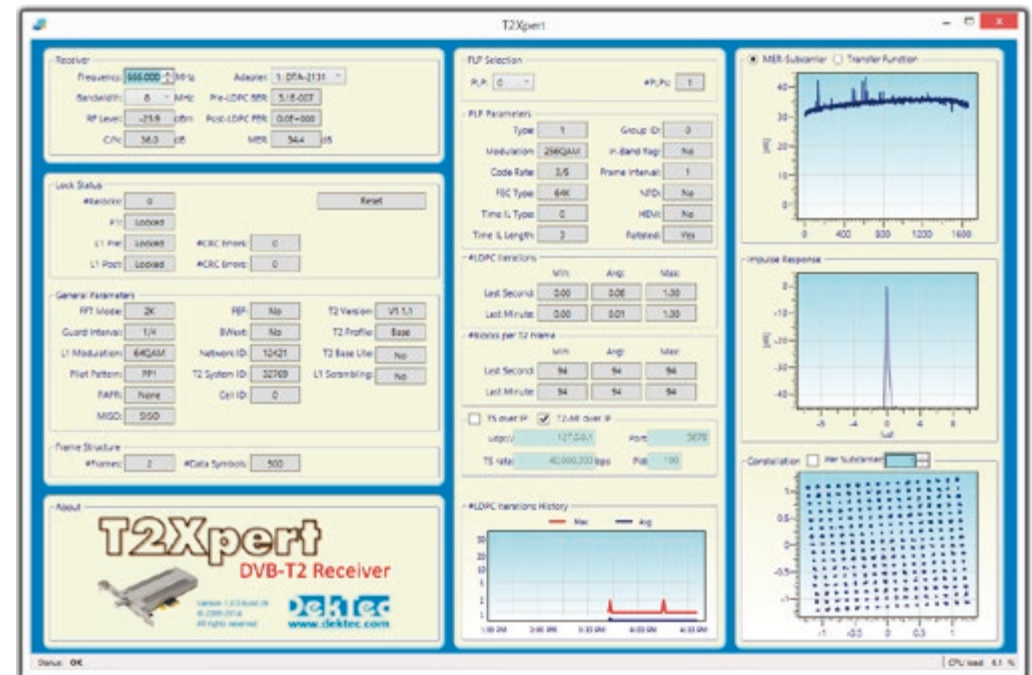

Parameters Displayed In Gui

Group	Parameters
RF	RF level, C/N, MER
Lock Status	P1, L1 pre, L1 post, #CRC errors
General	FFT, GI, L1 mod, Pilot pattern, FEF, BWExt, PAPR, MISO, Network ID, Cell ID, System ID, T2 Version
Per PLP	Type, Group ID, Code rate, FEC, Rotated, Modulation, In-band, HEM, Frame itv, NPD, TI type, TI len

PC Requirements

Platform	Windows XP/Vista/7/8/10, 2GB RAM
Processor	Intel Core i7 920 (2.66Ghz)

Related Products

Type	Description
DTA-2131	Multi-standard VHF/UHF receiver
DTA-2131-RXA	DTA-2131 with advanced demodulator API for custom monitoring applications
DTC-378-T2	DVB-T2 modulation option for DTA-115, 2115B and DTU-215, 315

Ordering Information

Type	Description
DTA-2131-RXA-SX	DTA-2131 with T2Xpert, C2Xpert and StreamXpert®

Features

- Real-time application for demodulating DVB-C2, displaying signalling information and outputting a demodulated Transport Stream on UDP
- Works with DTA-2131
- Measures RF level, C/N and MER
- Gathers statistics about number of LDPC iterations required to correct all errors and displays LDPC iterations history in a graph
- Shows Constellation per PLP, Impulse Response, MER per PLP and Transfer function graphs

Applications

- Measurements and analysis of DVB-C2 signals
- DVB-C2 demonstrations
- DVB-C2 field trials

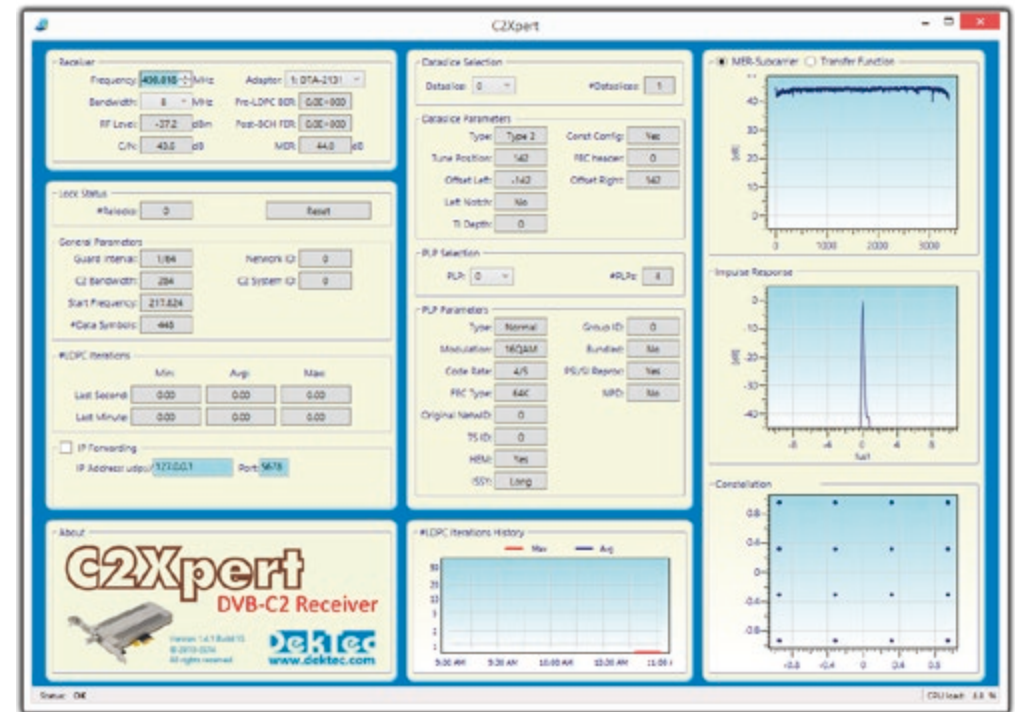

Parameters Displayed In Gui

Group	Parameters
RF	RF level, C/N, MER
General	GI, C2BWt, Start Freq, #Data Symb, Network ID, System ID
Per Dataslice	Type, Const conf, Tune Pos, FEC header, Offset left/right, Left notch, TI Depth
Per PLP	Type, Group ID, Code rate, FEC, Modulation, In-band, HEM, NPD, Bundled, PSI/SI reproc, TS ID, ISSY

PC Requirements

Platform	Windows XP/Vista/7/8/10, 2GB RAM
Processor	Intel Core i7 920 (2.66Ghz)

Related Products

Type	Description
DTA-2131	Multi-standard VHF/UHF receiver
DTA-2131-RXA	DTA-2131 with advanced demodulator API for custom monitoring applications
DTC-379-C2	DVB-C2 modulation option for DTA-115, 2115B and DTU-215, 315

Ordering Information

Type	Description
DTA-2131-RXA-SX	DTA-2131 with C2Xpert, T2Xpert and StreamXpert®

DTC-378 T2Xpress

DVB-T2 Signal Generator Software

Features

- Complete multi-PLP DVB-T2 modulator with full user control over general DVB-T2 parameters, T2-Frame structure and parameters per PLP
- T2-lite profile support
- Multi-profile stream generation, e.g. generate T2 lite and T2 base profile in each other's FEF
- Receiver Buffer Model (RBM) validation and corner cases stream generation with real video
- "Big-TS-splitter" function with SI processing for easy generation of multi-PLP streams with a common PLP from a standard Transport Stream
- Input from Transport-Stream files, built-in O151 PRBS generator or DVB V&V stream generator model
- Support for PAPR
- MISO simulation: Generation of I/Q sample files for both MISO transmitter signals with optional independent channel modelling of each signal
- Can be used in conjunction with DekTec's DTC-305-CM XpressSim channel simulator with AWGN generator (adjustable SNR), multipath fading, Rayleigh channels and Doppler simulation to accurately simulate reflections and a moving receiver

Applications

- Test-signal generator for DVB-T2 receiver chip development, testing and evaluation
- Signal generator for DVB-T2 receiver demonstrations and field trials

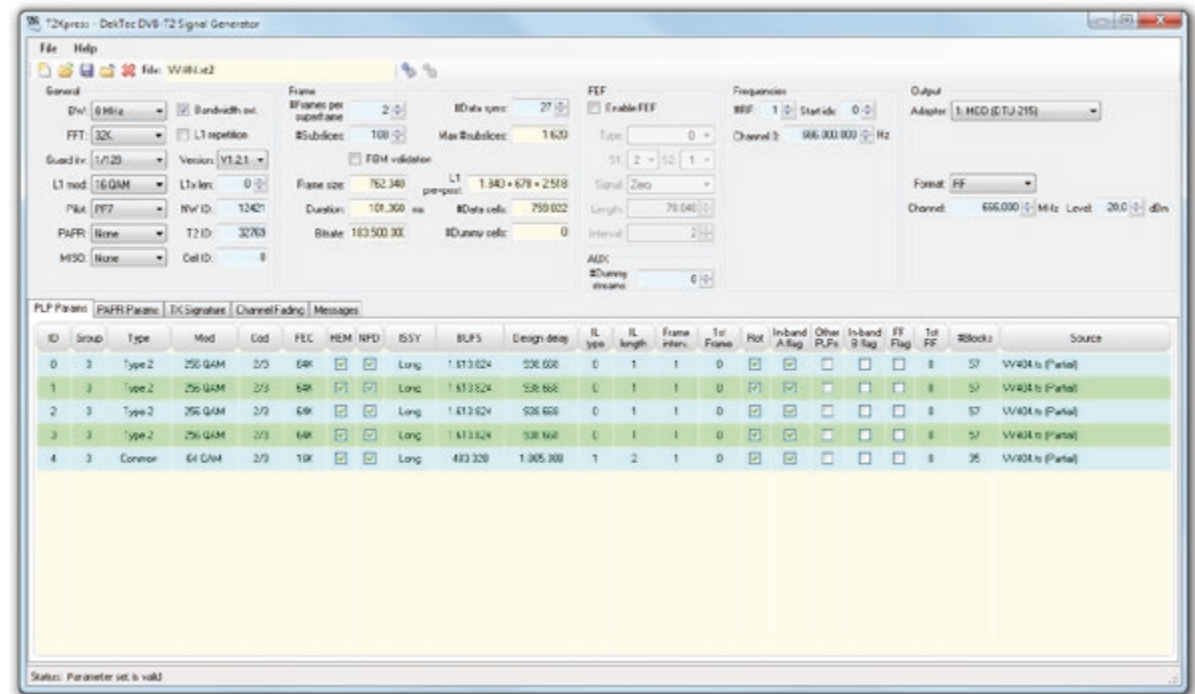

Supported Output Adapters

Output Format	Adapters / Format
RF	DTA-111, 115, 116, 117, 2111, 2115B DTU-215, 315
I/Q samples* in file	Float32, Int16, Text
Real-time T2-MI	All DekTec adapters supporting ASI or TS-over-IP
T2-MI in file	TS
Test point data* in file	TPs: 3, 4, 6, 8, 9, 11, 12, 15, 16, 19, 20, 21, 22, 23, 24, 25, 26, 27, 28, 29, 30, 32, 33, 34, 50, 51 and 53

* Requires DTC-371-IQ option

PC Requirements

Platform	Windows XP/Vista/7/8/10
Processor*	Core i7

* Or equivalent AMD processor

Related Products

Type	Description
DTC-305-CM	XpressSim channel-modelling option
DTC-371-IQ	I/Q sample generation option

Ordering Information

Type	Description
DTC-378-T2	T2Xpress DVB-T2 signal generator software

DTC-379 C2Xpress

DVB-C2 Signal Generator Software

Features

- Complete DVB-C2 modulator with file input and DVB-C2 RF output on e.g. DTA-115
- With DekTec's DTC-371-IQ option: Off-line generation of I/Q sample files
- Full user control over general DVB-C2 parameters, Data Slice parameters and parameters per PLP
- Input from Transport-Stream files or built-in O151 PRBS test-signal generator
- "Big-TS splitter" function with SI processing for easy generation of multi-PLP streams with a common PLP
- Can be used in conjunction with DekTec's DTC-305-CM XpressSim channel simulator with AWGN generator (adjustable SNR), multipath fading to accurately simulate reflections
- Adaptive Code and Modulation (ACM) support for the generation of streams with variable coding and modulation
- Optional generation of DVB-C2 Test-Point data

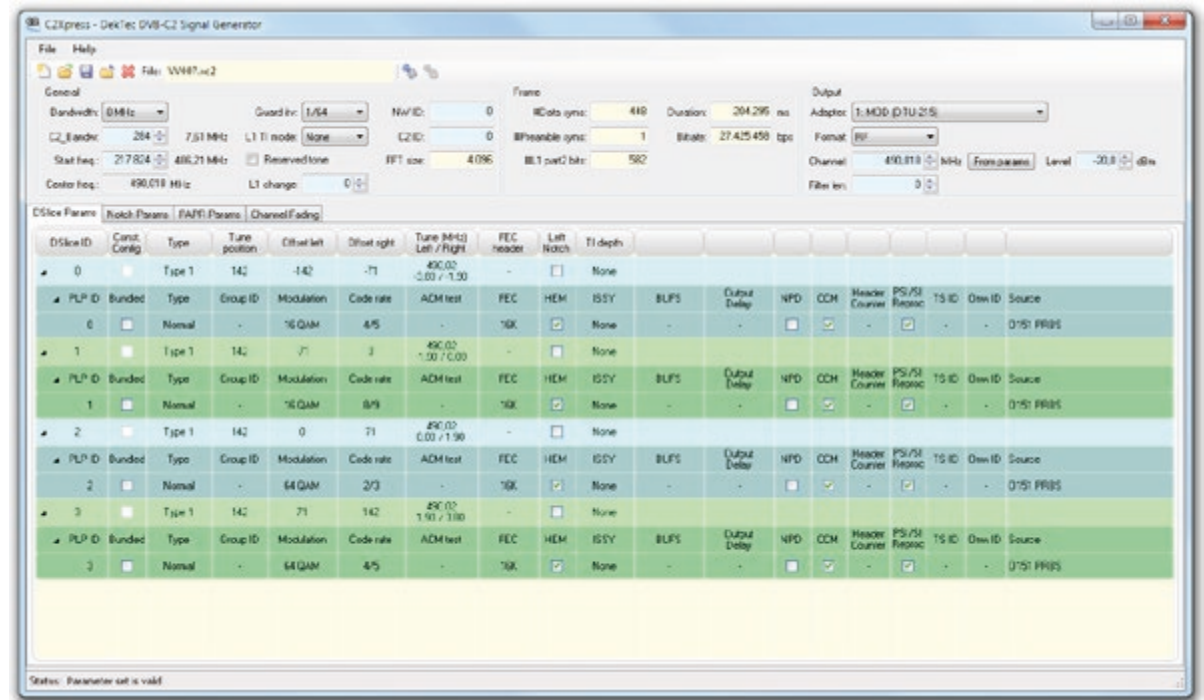

Applications

- Test-signal generator for DVB-C2 receiver chip development, testing and evaluation
- Signal generator for DVB-C2 receiver demonstrations and field trials

Supported Output Adapters

Output Format	Adapters / Format
RF	DTA-111, 115, 116, 117, 2111, 2115B DTU-215, 315
I/Q samples* in file	Float32, Int16, Text
Test point data* in file	TPs: 1, 7, 8, 10, 13, 15, 18, 20, 22, 26, 27, 31, 32, 33, 37, 40, 41 and 42

* Requires DTC-371-IQ option

PC Requirements

Platform	Windows XP/Vista/7/8/10
Processor*	Core i7

* Or equivalent AMD processor

Related Products

Type	Description
DTC-305-CM	XpressSim channel-modelling option
DTC-371-IQ	I/Q sample generation option

Ordering Information

Type	Description
DTC-379-C2	C2Xpress DVB-C2 signal generator software

DTC-382 TmmXpress

ISDB-Tmm Signal Generator Software

Features

- Complete ISDB-Tmm, TsB or T modulator compliant to ARIB STD-B46, with file input and RF output on e.g. DTA-2111
- 14.5MHz bandwidth (33 segments) on DTA-2111 or DTA-2115B
- With DekTec's DTC-371-IQ option: Off-line generation of I/Q sample files
- Full user control over all ISDB parameters
- Input from Transport-Stream files
- Can be used in conjunction with DekTec's DTC-305-CM XpressSim channel simulator with AWGN generator (adjustable SNR), multipath fading to accurately simulate reflections

Applications

- Test-signal generator for ISDB-T receiver chip development, testing and evaluation
- Signal generator for ISDB-Tmm demonstrations and field trials

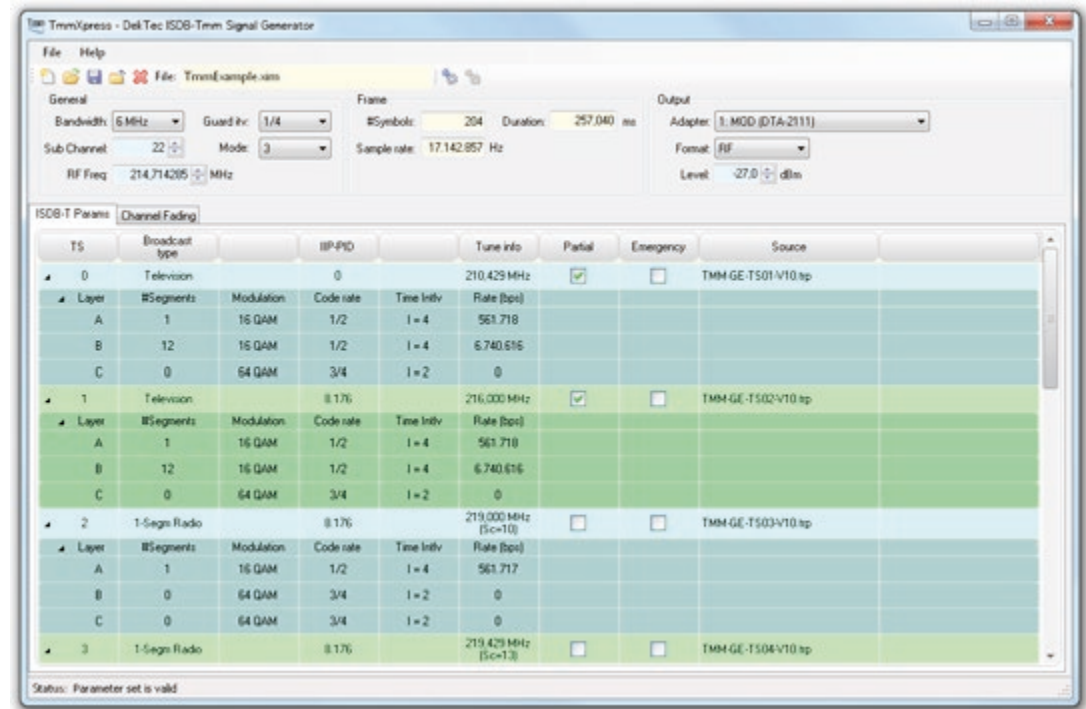

Key Parameters

Parameter	Range
Bandwidth	6, 7, 8, 14.5MHz
Guard interval	1/4, 1/8, 1/16 or 1/32
Mode	1 (2k), 2 (4k) or 3 (8k)
Sub channel	0 to 42
Broadcast type	TV, 1-seg or 3-seg radio
IIP PID	PID of the IIP
#Segments	0 to 13
Modulation	DQPSK, QPSK, 16- or 64-QAM
Code rate	1/2, 2/3, 3/4, 5/6, 7/8
Interleaving	0, 1, 2, 4, 8, 16
I/Q format*	Float32, Int16, Text
Real time output	ISDB-Tmm, Tsb, T

* I/Q format requires the DTC-371-IQ option

Related Products

Type	Description
DTA-2111	VHF/UHF modulator for PCIe
DTA-2115B	VHF/UHF/L-Band modulator for PCIe
DTC-300	StreamXpress® playout software
DTC-305-CM	XpressSim channel-modelling option
DTC-371-IQ	I/Q sample generation option
DTC-380-16MHZ	16-MHz bandwidth option

Ordering Information

Type	Description
DTC-382-TMM	TmmXpress ISDB-Tmm signal generator software

DTC-700 MuxXpert

Real-Time Multiplexer

Features

- Real-time multiplexing and re-multiplexing of live transport streams
- Integrated file players for the insertion of local content from disk into live streams
- Allows re-multiplexing of services and service components from any input to any output
- Automatic PSI and DVB-SI extraction, re-generation and insertion
- Recording of output transport stream
- Monitoring, control and programmatic access to the configuration through the *MuxXpert API*
- Runs on a standard- or industrial PC with all DekTec input and output adapters
- Flexible configuration allows adaptation of PIDs, services, tables, descriptors, etc.
- User interface provides information about services, components and bitrates in the input and output transport streams

Applications

- Master and head-end (re-)multiplexing
- Local program insertion
- Generating transport-stream bouquets
- Creation of fully customized transport streams from files and live feeds

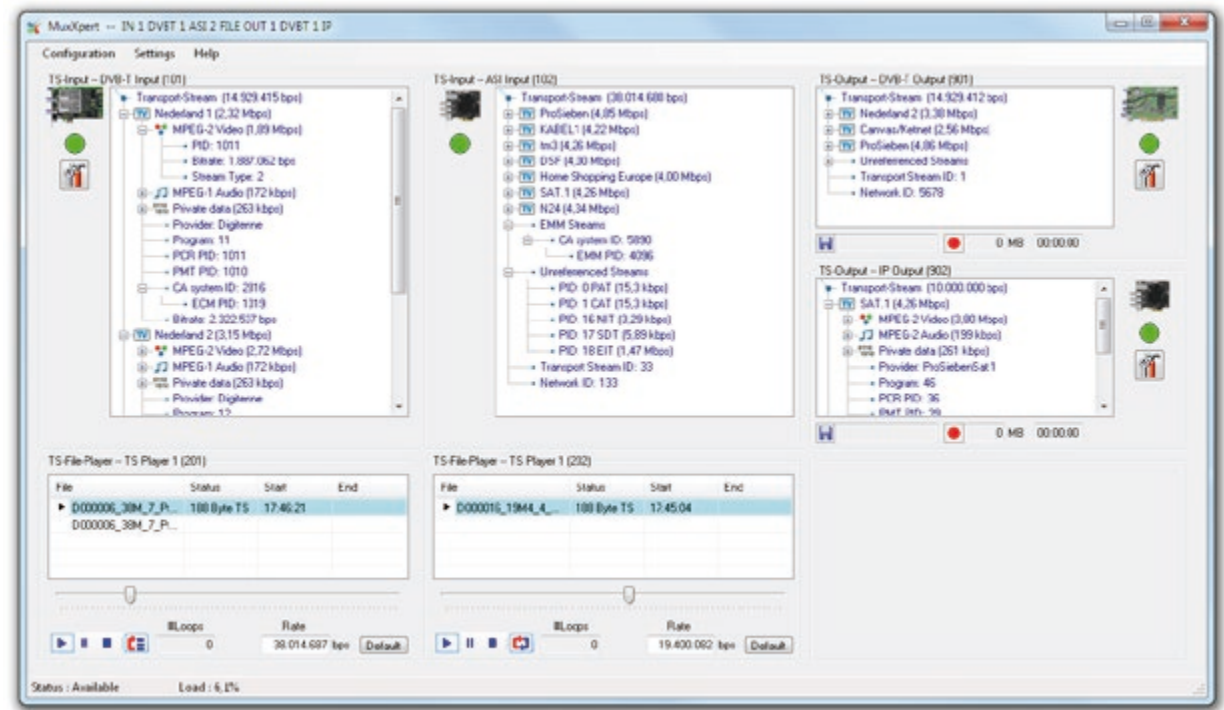

Key Attributes

Parameter	Value
Number of TS inputs	0 to 64*
Number of TS outputs	1 to 64*
Number of file players	0 to 32*
Sum of input rates	0 to 300Mbit/s
Sum of output rates	0 to 300Mbit/s

* Not all combinations are allowed and depend on CPU speed and RAM. A limited number of channels are shown in the UI.

PC Requirements

Platform	Windows XP/2k3/Vista/2k8/7/8/10 1GB to 4GB
Processor*	Core i5, i7

* Or equivalent AMD processor

Supported I/O Adapters

Bus	Types
PCI	All DekTec PCI adapters
PCI Express	DTA-2107, 2111, 2115B, 2131, 2136, 2137C, 2138B, 2139, 2144A, 2145, 2152, 2154, 2160, 2162, 2174
USB	DTU-215, 315, 245*
IP	DTE-3100, 3120, Local NIC

* For evaluation and demos, not recommended for operational use.

Ordering Information

Type	Description
DTC-700-MX	<i>MuxXpert</i> MPEG-2 multiplexer
DTDONG-1-MX	<i>MuxXpert</i> license on a USB dongle*

* For using MuxXpert with DTE-3100/3120 and/or local NIC.

DTC-706 MuxXpert SDK

SDK for Creating Custom Multiplexing Applications

Features

- The MuxXpert SDK is a development kit for the embedding of real-time multiplexing functions in your custom application
- The classes can be used to create custom:
 - Service and component selection
 - SI processing
 - Remote control
 - User interface
- Provides all functions of the MuxXpert: re-multiplexing of services and components, querying the structure of transport streams, SI extraction, table cycling, adaptation of PIDs, services, tables and descriptors
- Runs on a standard- or industrial PC with all DekTec input and output adapters
- Can be used from any .NET language such as C++/CLI, C# or VB.NET
- Location transparency: The real-time multiplexing functions running on one PC can be used from anywhere on the network
- MuxXpert SDK consists of one DTC-700-MX MuxXpert license, one DTC-705-MR run-time license, manual and help file, merge module and four hours of premium support

Applications

- Re-multiplexer with custom SI processing
- Electronic Program Guide inserter
- Generation of MuxXpert configuration files

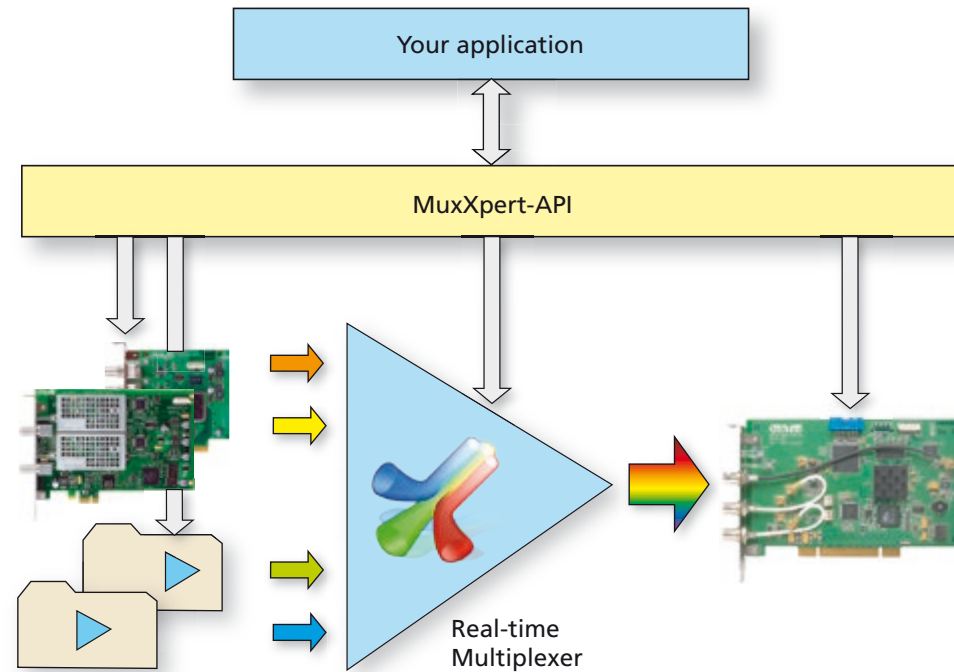

Key Attributes

Parameter	Value
Number of TS inputs	0 to 64*
Number of TS outputs	1 to 64*
Number of file players	0 to 32*
Sum of input rates	0 to 300Mbit/s
Sum of output rates	0 to 300Mbit/s

* Not all combinations are allowed and depend on CPU speed and RAM.

PC Requirements

Platform	Windows XP/2k3/Vista/2k8/7/8/10 1GB to 4GB
Processor*	Core i5, i7

* Or equivalent AMD processor

Supported I/O Adapters

Bus	Types
PCI	All DekTec PCI adapters
PCI Express	DTA-2107, 2111, 2115B, 2131, 2136, 2137C, 2138B, 2139, 2144B, 2145, 2152, 2154, 2160, 2162, 2174
USB	DTU-215, 315, 245*
IP	DTE-3100, 3120, Local NIC

* For evaluation and demos, not recommended for operational use.

Ordering Information

Type	Description
DTC-705-MR	MuxXpert runtime license (1PC)
DTC-706-MS	MuxXpert SDK

DTC-720 Xpect®

24/7 Transport-Stream Monitoring Software

Features

- Simultaneous monitoring of multiple transport streams
- Mosaic multi viewer included, see DTC-720 Xpect® Mosaic
- Web interface supports live video and audio decoding
- Full TR 101 290 conformance testing
- Freeze frame, black frame, audio silence detection
- Template Matching: Checks properties of services, service components and tables
- Capturing of the monitored transport stream to a file, with pre- and post-trigger buffer, client initiated or triggered by a TR 101 290- or template violation
- Maintains detailed statistic information about bitrates, PCR and IP jitter and packet loss
- Can be integrated with 3rd party monitoring systems for 24/7 network supervision
- SOAP and SNMP interface for remote control and automated access to statistics and error-event database
- Web interface for remote configuration and access to event log and statistic information
- Includes configuration tool for easy creation of templates and TR 101 290 profiles
- Forwarding of transport stream over IP for remote real-time analysis or viewing
- Template matching for DVB/teletext subtitles, closed captioning and SCTE-35
- Export event log to a CSV file

Applications

- 24/7 Network supervision
- Automated equipment test and validation

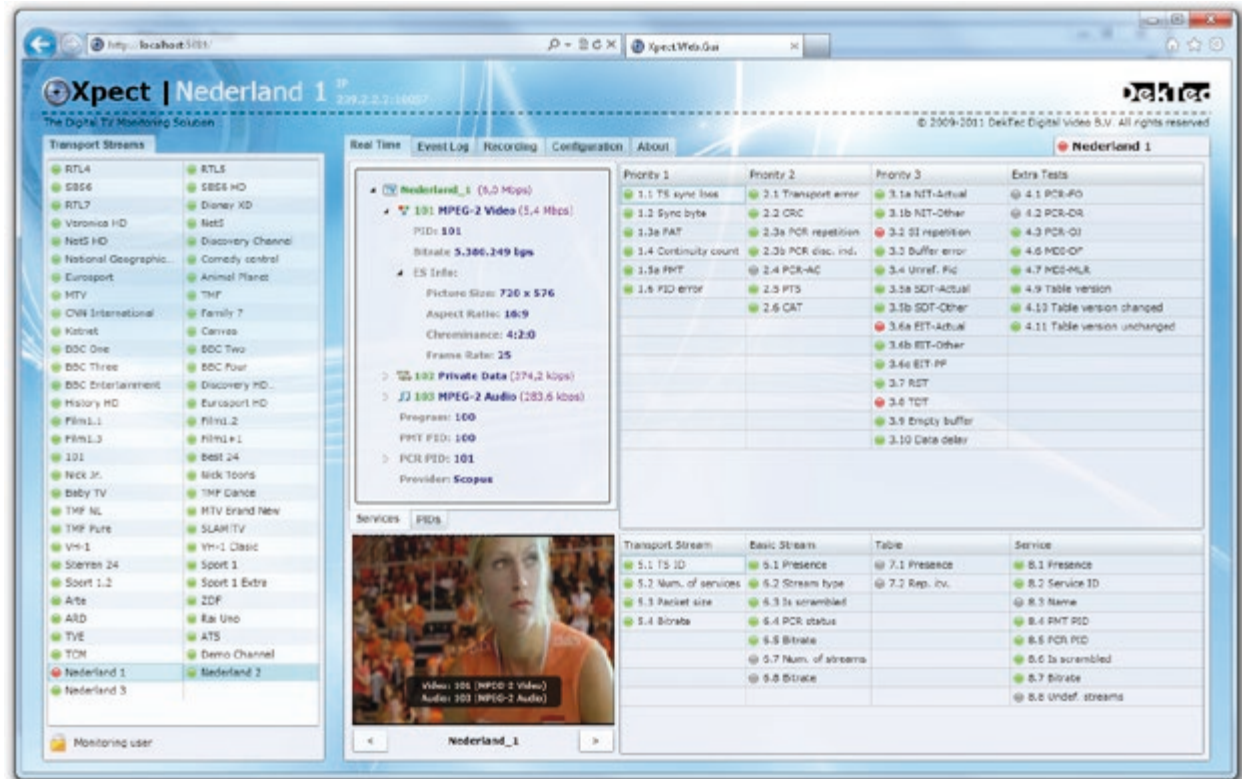

Supported Input Adapters

Signal Type	Supported Adapters
DVB-ASI	DTA-145, 160, 2144B, 2145, 2152, 2154, 2160, 2174 DTE-3120, DTU-225*, 245*
DVB-S/S2	DTA-2137C, DTE-3137
DVB-T/T2/C/C2	DTA-2138B
ISDB-T	DTA-2131
QAM	DTA-2136, 2139
TS-over-IP	DTA-160, 2160, 2162 Local NIC

* For evaluation and demos, not recommended for operational use

Key Attributes

Parameter	Value
Typical #TS that can be monitored	40 MPTS @ 40Mbit/s 250 SPTS @ 6Mbit/s
Platform	64-bit Windows 2k8/7/8/10

Ordering Information

Type	Description
DTC-720-nPT	Xpect® monitoring, n points*
DTC-720-DGL nPT	n points* on a dongle
DTC-7201-YR	1 year of software maintenance

* Each SPTS Video requires 1/2 point; each SPTS Audio requires 1/4 point, each MPTS requires 4 points

DTC-720 Xpect® Mosaic Multi Viewer

Features

- Creates an easy-to-oversee mosaic of decoded video, sub titles, audio bars and monitoring status
- Software-based solution that runs on standard PC hardware
- Supports MPEG-2 and AVC video, SD and HD
- Loudness indicators compliant to EBU R 128
- Multiple subtitles support for DVB, Teletext and CC
- Picture cells with custom contents
- Customisable clock
- Alarms from the Xpect® monitoring core can be visualized in the mosaic using LED indicators or a red border
- Customisable XML templates to change size and position of each display element, as well as colours, text font, etc.
- Supports multiple DekTec input devices to combine e.g. ASI and IP inputs
- Graphics card acceleration
- HDMI/DVI/xVGA output using standard PC graphics card or HD-SDI using DTA-2152
- Support for multiple mosaic screens
- Remote configuration tool for easy definition and uploading of a mosaic
- Predefined mosaic layout or fully customisable using 'drag and drop'
- Dynamic mosaic updates using SOAP interface, like service switching and text overlay

Applications

- Control room monitoring
- Impressive display of the services generated or received in your facility
- Fully customisable OEM multi viewer

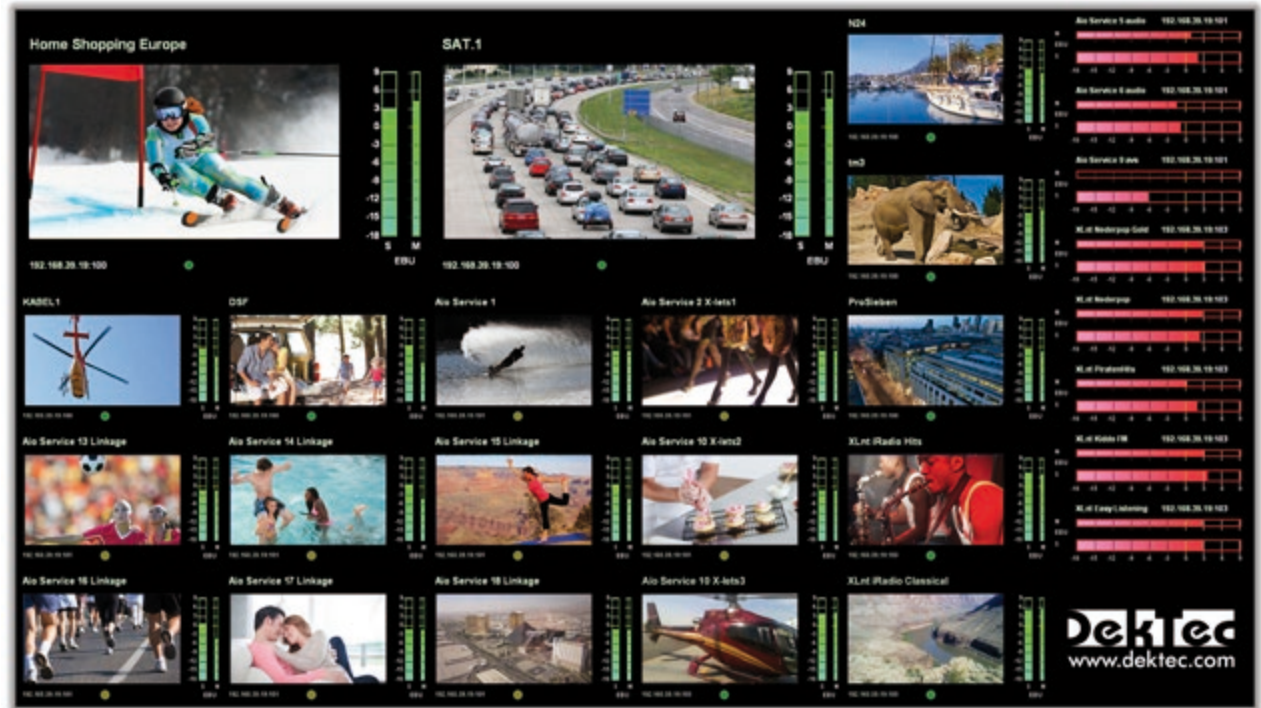

Monitored Stream Types

Type	Standard
Audio	Standard
	MPEG-1
	MPEG-2
	AC-3
Video	(HE-)AAC
	MPEG-2
DVB subtitles	AVC/H264
Teletext subtitles	EN 300 743
Closed Captioning	ETS 300 706
Status	EIA/CEA-608-B
	TR 101 290
	Template status

Key Attributes

Parameter	Value
Performance indication	60x SD MPEG-2, or
example for 64-bit Win 7 Intel Core i7 3770*	9x HD-AVC, or
	5x HD AVC + 30x SD AVC/MP2V
Platform	64-bit Windows 2k8/7/8/10
Processor	High-end Core i7

* Actual figures could be lower or higher depended on complete PC and Xpect® configuration

Ordering Information

Type	Description
DTC-720-nPT	Mosaic functionality is part of the DTC-720 Xpect® product; No extra license points are required

DTAPI

Uniform API for DekTec Digital Video Adapters

Features

- Common C++/.NET interface to DekTec's line of digital-video interface adapters
- Includes **Matrix API** for manipulating 3G/HD-SDI and **Advanced Demodulator API** for RF measurements and multiple stream demodulation
- Applications written for one device will work for any other DekTec device
- Encapsulates the device-driver layer in an easy-to-use object-oriented interface
- Access to all hardware features from user-mode programs
- High efficiency; no need to resort to kernel-mode programming to achieve real-time operation
- Same API classes and methods can be used for PCI, PCI Express, USB-2 and networked devices
- Same API classes and methods can be used on Windows and Linux
- Packaged in a C++ header file (to be included in your C++ project) and a library (to be linked to the application)
- Free download
- Royalty-free redistribution in custom applications

Applications

- Creating custom applications with DekTec devices in a convenient way

Note

DTAPI cannot descramble services

Software Development Kits

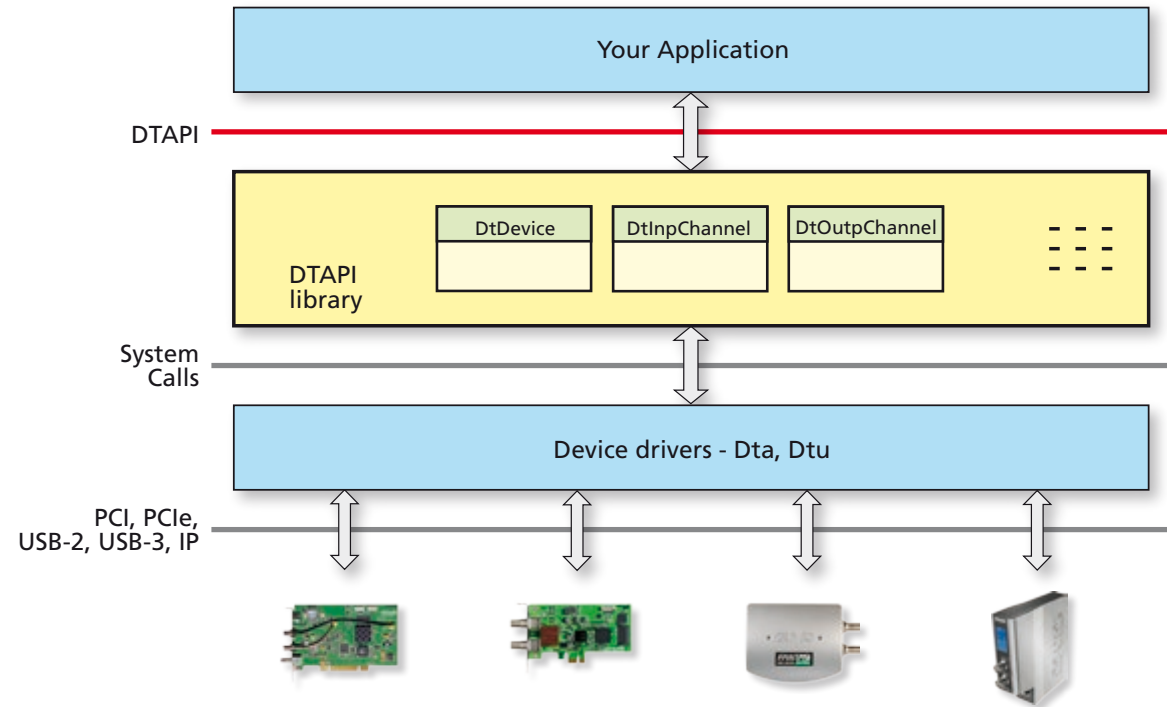

Supported DekTec Devices

Signal Type	Supported Adapters
DVB-ASI	DTA-100, 105, 120, 140, 145, 160, 2160 DTE-3100, 3120
DVB-SPI	DTA-102, 122, 2142
ASI/SDI	DTA-124, 145, 2142, 2144B, 2145, 2152, 2154, 2174 DTU-350, 351
Modulators	DTA-107, 110, 111, 112, 115, 116, 117, 2107, 2111, 2115B DTU-215, 315
Receivers	DTA-2131, 2135, 2136, 2137C, 2138B, 2139 DTU-234, 235, 236A
TS-over-IP	DTA-160, 2160, 2162
H.264 encoder	DTA-2180

PC Requirements

Platform	Windows XP/2k3/Vista/2k8/7/8/10 Linux ≥2.6.18, 3.x, 4.x
Processor	Any x86 processor

Main Classes In DTAPI

Class	Represents
DtDevice	DekTec device
DtInpChannel	Input channel
DtOutpChannel	Output channel
DtSdi	SDI helpers
DtFrameBuffer	3G/HD/SD-SDI frame buffer
DtSdiMatrix	Matrix of SDI frame buffers

DTAPI-TS

Transport-Stream Analysis and Monitoring SDK

Features

- C++ library for adding transport-stream analysis functions to your application
- Get list of services, service info (e.g. name) and elementary stream info (e.g. audio sample rate or video resolution)
- Bitrate measurement (average/min/max) with programmable sliding window
- PCR analysis with PCR-AC and PCR-OJ
- Full decoding of PSI, DVB-SI and ATSC PSIP tables and descriptors
- User-supplied callback functions can be fired upon certain events, e.g. when table data has changed, when a new PES packet was received, etc.
- Easy to use: (1) supply packets with the NewData() function, and (2) read analysis results from class DtTsData
- Transport-stream data can be supplied from any source: DekTec input card, file, network data, 3rd party hardware
- Single developer and site license available
- Applications developed with DTAPI-TS can be used or distributed royalty free

Applications

Apply transport stream analysis and monitoring to the transport stream input(s) of your application, without writing any parsing code:

- Discover services and streams
- Create TS information display
- Detect transport stream errors
- Get contents of SI tables and/or descriptors

Software Development Kits

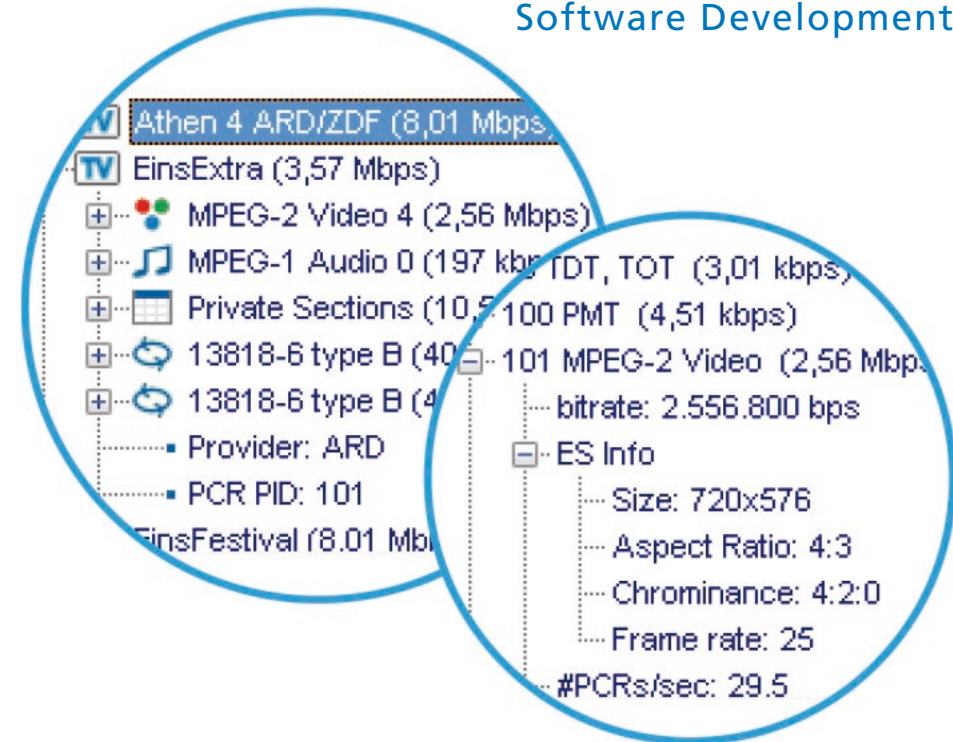

Service information extraction (DVB/ATSC)
PCR analysis and bitrate measurement
Modest NRE fee; Royalty-free distribution

General Info

Platform	Windows, Linux
Language	C++
Threading	Locking mechanism for usage in multi-threaded applications
Compiler	Visual Studio 2010 or later gcc v4.1 or later
Processor	Any x86 processor

Ordering Information

Type	Description
DTC-730-1DEV	DTAPI-TS, Transport Stream analysis SDK, single developer
DTC-7301-YR	1yr software maintenance for DTC 730-1DEV
DTC-732-SITE	DTAPI-TS, site license
DTC-7321-YR	1yr software maintenance for DTC 732-SITE

Distributors

DekTec products are shipped worldwide. Please direct any commercial enquiries or formal quotation requests to the appointed distributor in your country. A list of officially appointed distributors is provided in the contact section of our website. If no distributor is listed for your country, you can email directly to info@dektec.com.

Open Pricing

DekTec operates an open pricing policy. You can find the latest prices of each product on our website. Distributors shall not charge a price that exceeds the DekTec published price, but please beware that local prices may slightly exceed the

published prices to account for customs duties and currency exchange-rate fluctuations.

Credit Card Payment and Shipment

For urgent product requirements, DekTec accepts payment by credit card (VISA and MasterCard). Shipment is worldwide by FedEx International Priority shipment, or by your preferred courier.

DekTec - The OEM Supplier

DekTec is a leading supplier of OEM components for integration in your solution. DTAPI, DekTec's critically acclaimed SDK, provides comprehensive support that reinforces the OEM-friendly nature of our products. We provide the SDK free of charge without NDA or complex registration requirement.

Extensive Range

Most of DekTec's product range in this catalogue is suitable for OEM, including the USB products that can be supplied as an assembled PCB board only. By keeping the products standard we can keep the cost of the OEM low, along with immediate stock availability.

DekTec's OEM Minimum Order Quantity = 1

For integrators and OEM's requiring small quantities, e.g. for development of your solution or for a test run, DekTec units are available in single quantity immediately from stock.

Custom Branding

We will consider custom branding to meet specific OEM client requirements, subject to a minimum order quantity.

Warranty

DekTec's hardware is supported with a no-quibble two-year worldwide warranty. This period can be optionally extended up to seven years to provide added assurance in your critical applications.

DekTec Software

DekTec software is supplied on a USB flash drive* and via the Downloads section on our website. We provide a utility program DtInfo to help checking proper installation, licensing information, serial numbers and driver version numbers. DtInfo can also be used to install newly purchased licenses. Software upgrades are available freely for a period of one year after purchasing.

* supplied when hardware and software is purchased together.

Pleasure in the job puts perfection in the work.

Aristotle



DekTec Digital Video B.V. - Godelindeweg 4, 1217 HR Hilversum - The Netherlands
info@dektec.tv - Tel: +7 495 2218188 - Fax: +7 495 2218188 - www.dektec.tv



[Back to content](#)