

MEYER | BORGMAN | JOHNSON
STRUCTURAL DESIGN + ENGINEERING

Delegated Design

Presented by:
Matt Huber, PE & Lindsey Schultz, SE
February 12, 2019

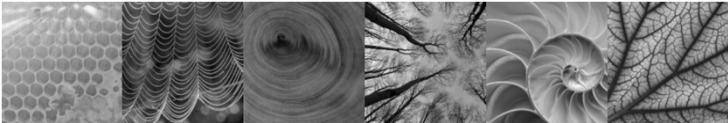

Visit our web site at www.mbjeng.com SEE STRUCTURE.

Delegated Design Overview

- Delegate: To entrust a task or responsibility to another.
- Commonplace in construction industry
 - Precast Design
 - Steel Connections
 - Cold Formed Steel Design
- Can benefit the project when done properly.



MEYER | BORGMAN | JOHNSON
STRUCTURAL DESIGN + ENGINEERING

Part 1: Delegated Connection Design

Presented by:
Matt Huber, PE, Associate and Manager of Steel Fabricator Services

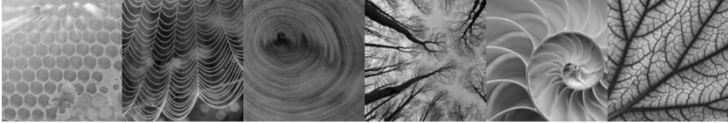

Visit our web site at www.mbjeng.com SEE STRUCTURE.

Part 1: Delegated Connection Design Outline

- Code of Standard Practice Requirements
- Delegated Design: Overview and Goals
- Current Industry Trends and Pitfalls
- Best Delegated Connection Design Practices
- Gaining Project Efficiency through Delegated Design

CODE OF STANDARD PRACTICE REQUIREMENTS

Code of Standard Practice Requirements

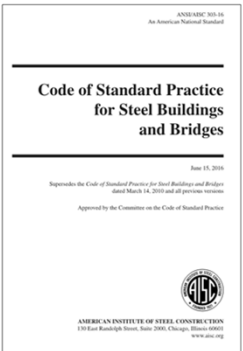

AISC 303-16 Section 3.1.1

- EOR must provide guidance on connection design
- 3 Options

Code of Standard Practice Requirements

Option #1

Connection design fully provided on contract documents (non-delegated)

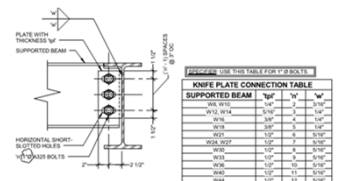

| GENERAL USE (SEE TABLE #2 OF 10 BOLTS) | | | |
|--|------|------|------|
| SUPPORTED BEAM | | | |
| WIP | WIP | WIP | WIP |
| W12 | W14 | W16 | W18 |
| W21 | W24 | W27 | W30 |
| W24 | W27 | W30 | W36 |
| W30 | W36 | W42 | W48 |
| W36 | W42 | W48 | W54 |
| W42 | W48 | W54 | W60 |
| W48 | W54 | W60 | W66 |
| W54 | W60 | W66 | W72 |
| W60 | W66 | W72 | W78 |
| W66 | W72 | W78 | W84 |
| W72 | W78 | W84 | W90 |
| W78 | W84 | W90 | W96 |
| W84 | W90 | W96 | W102 |
| W90 | W96 | W102 | W108 |
| W96 | W102 | W108 | W114 |
| W102 | W108 | W114 | W120 |

11 TYPICAL SHEAR CONNECTION
1'-2" x 1'-2"

- BOTH DOUBLE ANGLE AND KNIFE PLATE CONNECTION CONFIGURATIONS ARE ACCEPTABLE. UNLESS NOTED OTHERWISE, FABRICATION AND DETAILER SHALL SELECT WHICH OPTION IS BEST SUITED FOR THE FABRICATION PROCESS AND THE ANTICIPATED ERECTION PROCEDURES.
- DETAIL TO BE SIMILAR AT CONNECTIONS TO WIDER FLANGE OR IBS COLUMNS.
- UNLESS NOTED OTHERWISE, PROVIDE SHOWN CONNECTIONS AS INDICATED BY THIS DETAIL.
- DETAILER IS RESPONSIBLE FOR FULLY DEVELOPING GEOMETRY AND DIMENSIONAL INFORMATION REQUIRED TO FABRICATE.
- WHERE TYPICAL SHEAR CONNECTION DETAIL IS NOT APPLICABLE, FABRICATOR SHALL SELECT AND DETAIL AN ALTERNATE CONNECTION CAPABLE OF DEVELOPING EQUAL STRENGTH. ALTERNATE CONNECTION SHALL BE SELECTED IN ACCORDANCE WITH AISC AND CONNECTION TABLES.

Code of Standard Practice Requirements

Option #1: 2D Delivery

Most preferred non-delegated delivery.

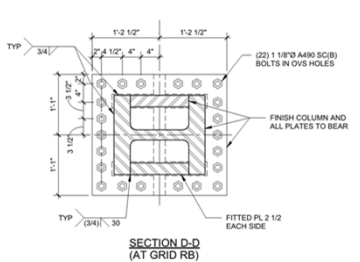

9 DETAIL
3/8" x 1'-2"

Code of Standard Practice Requirements

Option #01: EOR provides fully designed model.

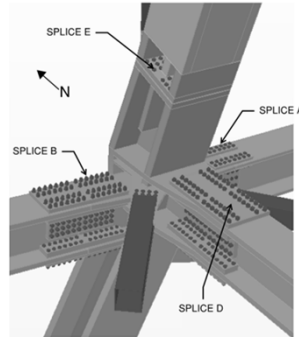
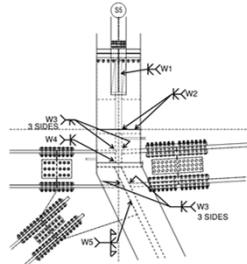

Code of Standard Practice Requirements

Option #2

The connection shall be designated to be selected or completed by an experienced detailer.

Code of Standard Practice Requirements

Option #3

The connection shall be designed by a licensed engineer working for the fabricator.

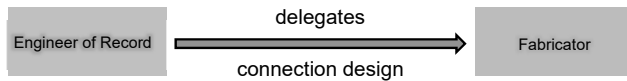

Location, Location, Location



Hybrid Approach to Connection Design

Combined Option #1 & Option #3

- EOR selects strategically what connections to design internally and which connections to delegate.
- Do some details require extra coordination?
- Do some details require certain performance requirements?
- Does review of third party design negate benefits of delegating?

DELEGATED DESIGN: OVERVIEW AND GOALS (OPTION #03)

Role of Engineer of Record in Delegated Process

- Design overall structure
- Prepare design drawings
- Communicate connection design information



Role of Fabricator in Delegated Process

- Procure and fabricate the structural steel
- Manage the connection engineer and erector

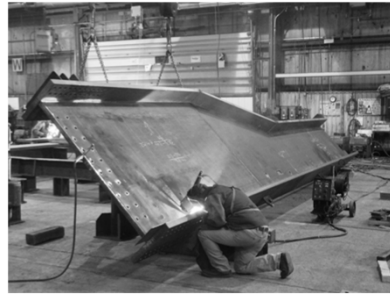

Role of Connection Engineer in Delegated Process

Design connections for the fabricator that meets design requirements set forth in the contract documents

Engineer of Record Self Interests

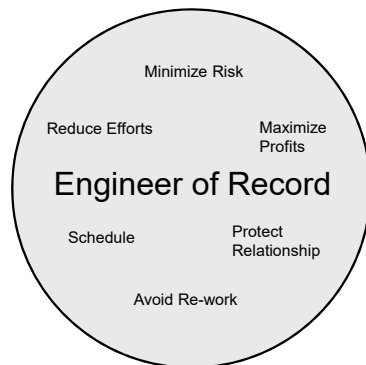

Fabricator Self Interests

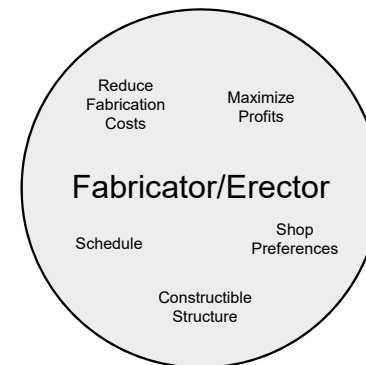

Connection Engineer Self Interests

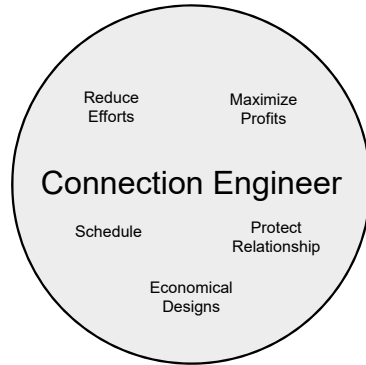

Intersecting Interests

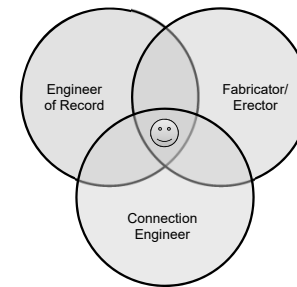

😊 The intersection of all parties' interests is where projects tend to be most successful!

CURRENT INDUSTRY TRENDS AND PITFALLS

Specifying Shear Loads

3 common ways of relaying shear load information

- % of uniform design load (UDL)
- Shear schedule
- Shear loads noted on design documents

Specifying Shear Loads

% of uniform design load (UDL)

- Typically 50%
- More for composite framing
- Defies logic
- Cost \$
- Quick and easy for EOR
- Reduces EOR risk (?)

Specifying Shear Loads

% of uniform design load (UDL) Example

- W10x22 x 4'-0" Long
- 50% UDL

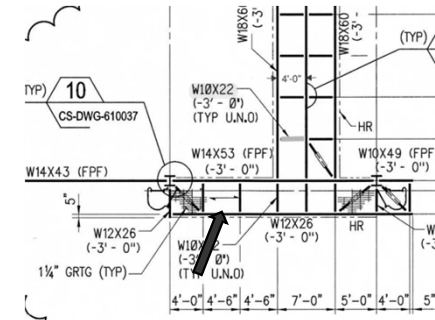

Specifying Shear Loads

% of uniform design load (UDL)

- Per 14th Edition AISC Manual Table 3-6, total load supported = 97.9 kips
- $V_a = 97.9 \text{ kips} / 2 = 49 \text{ kips}$
- Shear Capacity of member?
- This equates to 24.4 klf

Table 3-6 (continued)
Maximum Total Uniform Load, kips
W-Shapes

$F_y = 50 \text{ ksi}$

| Shape | W10- | | | | | | W12- | | | | | | W14- | | | | | | W16- | | | | | | W18- | | | | | |
|--------|------|-------|------|------|------|------|------|------|------|------|-----|------|------|------|-----|------|-----|------|------|------|-----|------|-----|------|------|------|-----|------|----|--|
| | 22 | | 19 | | 17 | | 15 | | 12 | | 10 | | 14 | | 12 | | 10 | | 14 | | 12 | | 16 | | 14 | | 18 | | 16 | |
| Design | ASD | LRFD | ASD | LRFD | ASD | LRFD | ASD | LRFD | ASD | LRFD | ASD | LRFD | ASD | LRFD | ASD | LRFD | ASD | LRFD | ASD | LRFD | ASD | LRFD | ASD | LRFD | ASD | LRFD | ASD | LRFD | | |
| 3 | | | | | | | | | | | | | | | | | | | | | | | | | | | | | | |
| 4 | | | | | | | | | | | | | | | | | | | | | | | | | | | | | | |
| 5 | | | | | | | | | | | | | | | | | | | | | | | | | | | | | | |
| 6 | 32.9 | 147 | 58.2 | 130 | 74.7 | 112 | 53.9 | 96.0 | 49.8 | 75.0 | | | | | | | | | | | | | | | | | | | | |
| 7 | | | | | | | | | | | | | | | | | | | | | | | | | | | | | | |
| 8 | 64.9 | 97.5 | 53.9 | 91.0 | 48.7 | 70.1 | 38.9 | 60.0 | 31.2 | 45.9 | 175 | 203 | | | | | | | | | | | | | | | | | | |
| 9 | 97.7 | 160.7 | 47.9 | 72.0 | 41.5 | 60.0 | 35.3 | 57.5 | 41.7 | 155 | 234 | | | | | | | | | | | | | | | | | | | |
| 10 | 51.9 | 78.0 | 43.1 | 64.8 | 37.3 | 56.1 | 31.9 | 48.0 | 25.0 | 37.5 | 140 | 210 | | | | | | | | | | | | | | | | | | |
| 11 | 47.2 | 70.9 | 39.2 | 58.9 | 33.9 | 51.0 | 29.0 | 43.6 | 22.7 | 34.1 | 127 | 191 | | | | | | | | | | | | | | | | | | |

Specifying Shear Loads

% of uniform design load (UDL)

- An F150 weighs approximately 6,000 pounds
- A reaction of 49 kips at each end means this W10x22 would be supporting (16) F150s!



Specifying Shear Loads

% of uniform design load (UDL)

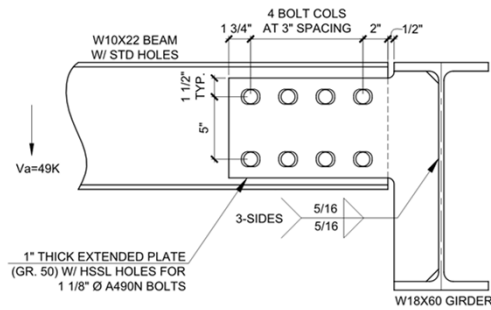

Specifying Shear Loads

% of uniform design load (UDL)

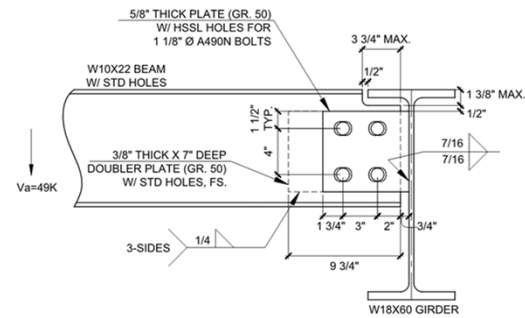

Specifying Shear Loads

Shear schedule

- Typical shear provided for each nominal depth
- Little effort from EOR
- Typical shears may be high to cover all cases
- Taxing on lightly loaded members

| BEAM VERTICAL SHEAR REACTION SCHEDULE | |
|---------------------------------------|--------------------------|
| NOMINAL STEEL BEAM SIZE | FACTORED REACTION (KIPS) |
| W8 | 22 |
| W10, C10 | 22 |
| W12, HSS10, HSS12 | 45 |
| W14 | 45 |
| W16 | 65 |
| W18 | 100 |
| W21 | 120 |
| W24, W27 | 150 |
| W30 | 180 |
| W33 | 200 |
| W36 | 230 |
| W40, W44 | 275 |

① TYPICAL BEAM CONNECTION SCHEDULE
12" = 1'-0"

Specifying Shear Loads

Shears shown on plan

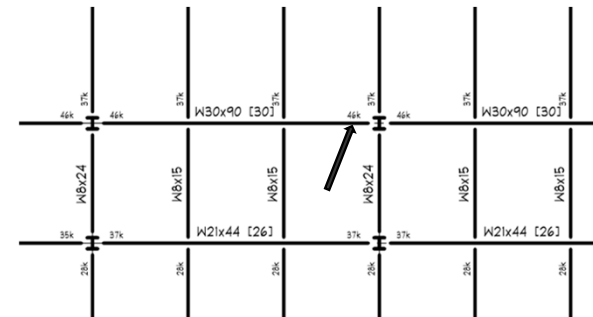

Specifying Moment Loads

- Full flexural capacity
- Design moment loads provided at each location
- Moment load schedule

| BEAM END MOMENT SCHEDULE | |
|-----------------------------|---------------------------------|
| NOMINAL STEEL BEAM SIZE | FACTORED MOMENT (KIP - FEET) |
| W12 | 70 |
| W24 | 150 |
| W27 | 175 |
| W30 | 200 |
| W33 | 250 |

NOTE:
T₁ MOMENT APPLIES WHERE MOMENT
SYMBOL APPEARS ON PLAN



BEST DELEGATED CONNECTION DESIGN PRACTICES

Who's Responsible For This Mess?

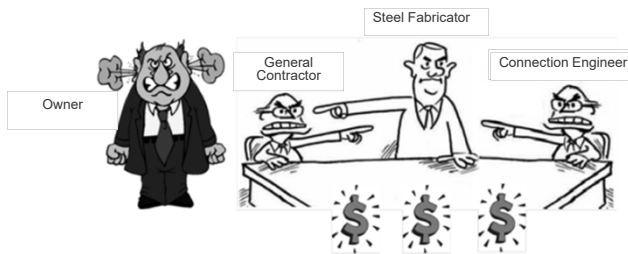

It's ALL About Communication!



What Does the EOR Need to Communicate?

Reference AISC 303-16 Section 3.1

- Materials
- Geometry
- Loading information
- Top of steel elevations
- Bidding information for member reinforcement

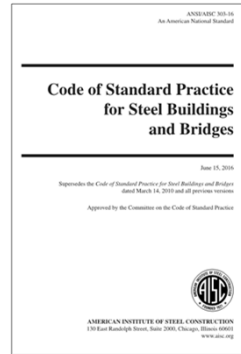

What Else Should the EOR Communicate?

- Permitted connection concepts
- Connection type restrictions
- Special load path requirements
- Other special requirements?



Don't wait for the approval process to provide these clarifications!

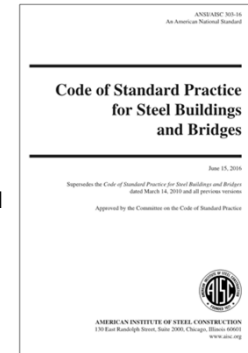

Fabrication Stats: What You Didn't Know!

Fabrication cost impacts of were discussed with a number of fabricators.



Connection Costs Large Impact on Bottom Line



Fabrication Stats: What You Didn't Know!

- 10-15% of fabrication weight is assumed to be assigned to connection material
- 20-50% of fabricated cost of steel is associated with connections
- Field welding costs up to 2x more than shop welding

Something doesn't add up!



Best Practice in Communicating Shear Loads

Reasonable shear schedule with larger loads shown on plan

BEAM SHEAR CONNECTION SCHEDULE (AISC 360-10 LRFD)

| BEAM SIZE | MINIMUM NUMBER BOLT ROWS | MINIMUM CONNECTION SHEAR CAPACITIES: (FACTORED, V_u) (KIPS) |
|-----------|--------------------------|--|
| W8 | 2 | 10 |
| W10 | 2 | 15 |
| W12 | 3 | 30 |
| W14 | 3 | 40 |
| W16 | 3 | 55 |
| W18 | 4 | 70 |
| W21 | 4 | 90 |
| W24 | 5 | 110 |
| W27 | 6 | 130 |
| W30 | 7 | 150 |
| W33 | 7 | 170 |
| W36 | 8 | 225 |
| W40, W44 | 9 | 275 |



Best Practice in Communicating Shear Loads

BEAM SHEAR CONNECTION SCHEDULE (AISC 360-10 ASD)

| BEAM SIZE | MINIMUM NUMBER BOLT ROWS | MINIMUM CONNECTION SHEAR CAPACITIES: (SERVICE, V_a) (KIPS) |
|-----------|--------------------------|---|
| W8 | 2 | 6 |
| W10 | 2 | 10 |
| W12 | 3 | 20 |
| W14 | 3 | 25 |
| W16 | 3 | 35 |
| W18 | 4 | 45 |
| W21 | 4 | 60 |
| W24 | 5 | 70 |
| W27 | 6 | 85 |
| W30 | 7 | 100 |
| W33 | 7 | 110 |
| W36 | 8 | 150 |
| W40, W44 | 9 | 180 |



Best Practice in Communicating Shear Loads

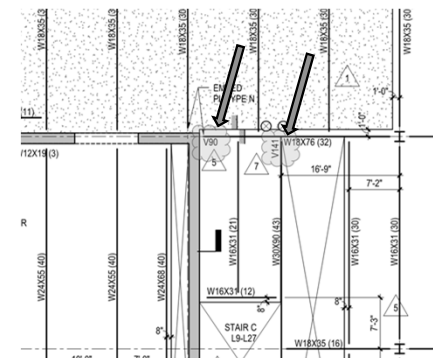

Best Practice in Communicating Moment Loads

Provide design moment at all locations

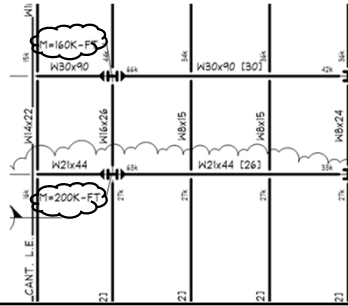

Allow Moment Connection Options

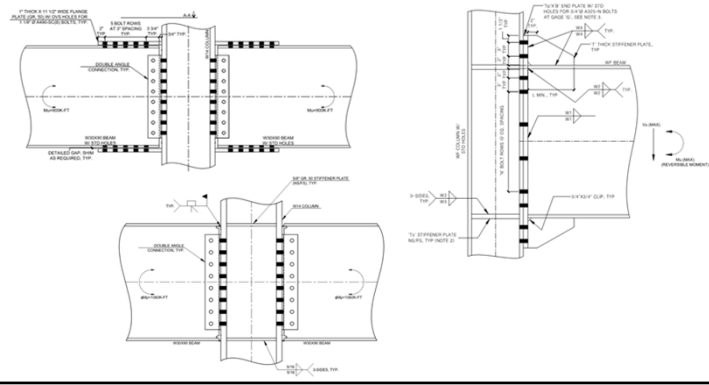

Alternative to Full Flexural Capacity

- Full flexural capacity requires....
 - Direct welded connection
 - Reinforced or unreinforced flange plated connection

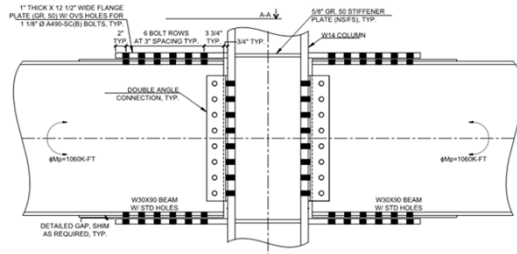

Flange Reinforcement due to Flexure AISC Specification Section F13

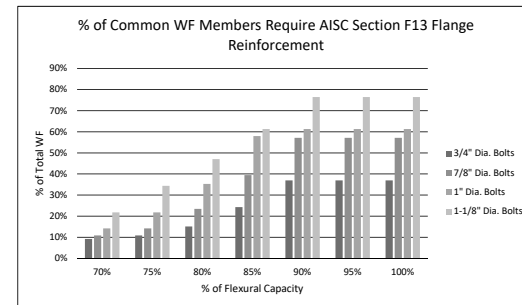

Reduce Reinforcing with Proper Member Selection

- Member Reinforcement = \$\$\$
- Size members to avoid stiffeners
- Avoid minimum reinforcing requirements

Proper way to delegate is to note reinforcement plate AS or WHEN required

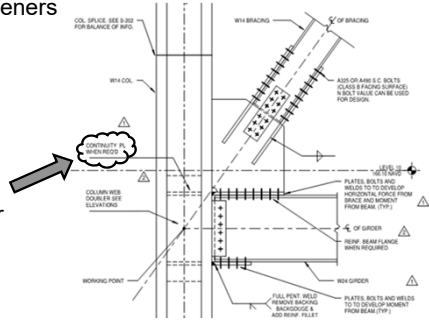

Reduce Reinforcing with Proper Member Selection

Is the Fabricator or the EOR responsible for understanding member reinforcement requirements?



Reduce Reinforcing with Proper Member Selection

- COSP AISC 303-16 Section 3.1.2 puts some responsibility on EOR
 - Option A: Member reinforcement at connection provided by EOR at bidding time.
 - Option B: EOR provides concept and bidding quantity at bidding time.

Creates equal playing field for all Fabricators during bidding phase!

Proper Member Selection

Prices Based on Fabricator Input...

- Average WF column = \$900-\$1200 per ton
- Average pair of stiffeners = \$156
- Single doubler = \$438

Comparison

- Unreinforced W14x90 x40'-0" long will cost roughly \$1600
- W14x90 x 40'-0" reinforced could cost up to \$3000

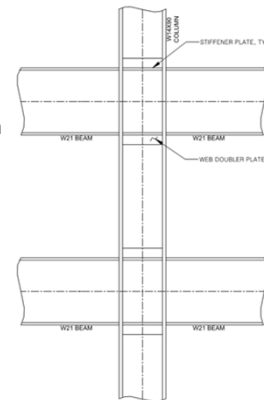

Proper Member Selection
 Prices Based on Fabricator Input...

Upsize to W14x132 costs roughly \$2375

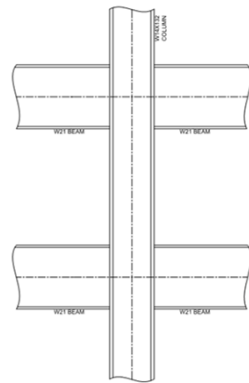

Moment Connection Cost Impact

Full Moment Capacity- Direct Welded

- Cheapest to fab
- Most expensive to erect
- Highest schedule impact

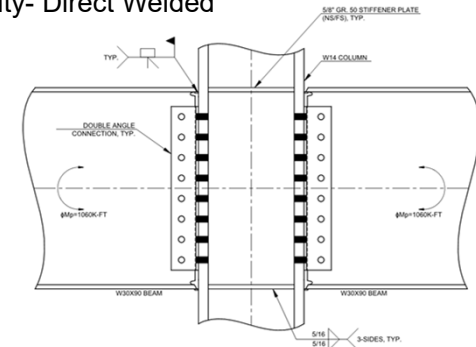

Moment Connection Cost Impact

Full Moment Capacity- Flange Plate with Reinforcement

- Most expensive to fab
- Average erection costs
- Negligible schedule impact

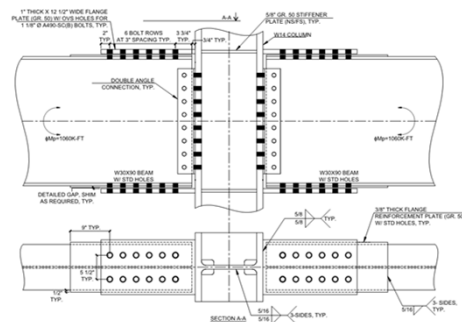

Moment Connection Cost Impact

Reduced Design Moment- Flange Plate

- Average fab costs
- Cheapest to erect
- Negligible schedule impact

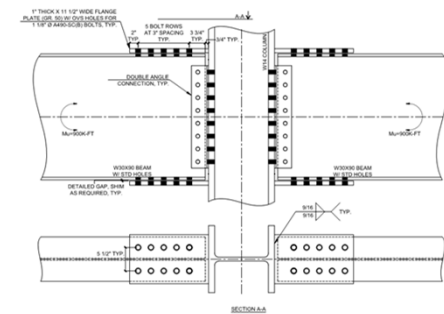

Cost Impact Summary

- Fabrication costs varied widely
- Erection costs varied widely
- Least desirable connection = direct welded
- Most preferable = flange plate (no reinforcement)



Give Fabricator Options!!

GAINING PROJECT EFFICIENCY THROUGH DELEGATED DESIGN

Tip#1: Relax on the Envelope Loads

- Provide loading clarity
- Keep an eye on your interaction checks
- Tabulated connection information

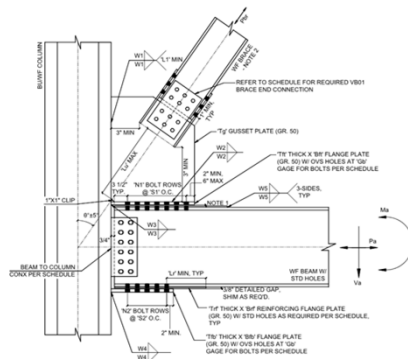

Tip#2: Vertical Brace Loads

- Provide Axial Loads
- Provide Different Tension vs. Compression Loads
- No load combinations

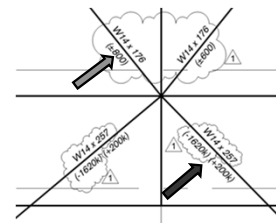

Tip#3: Vertical Brace Force Directionality

- Is bracing tension and compression only?
- Be clear with specific vertical brace loading requirements.

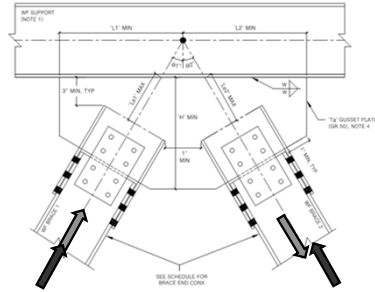

Tip#3: Vertical Brace Force Directionality

Critical details should require more attention to detail.

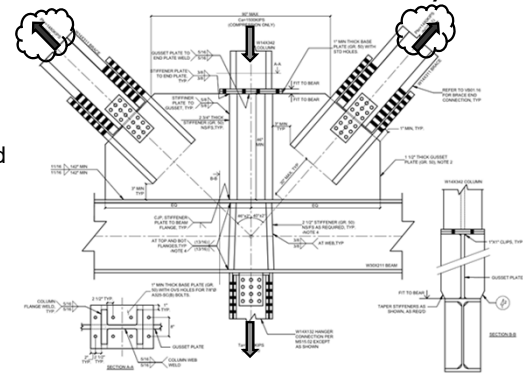

Tip#4: Vertical Brace Force Minimums

- Minimum bracing loads
- % of capacity



Simply provide design loads

Tip#5: Brace Connection Load Distribution

Do not provide connection interface forces

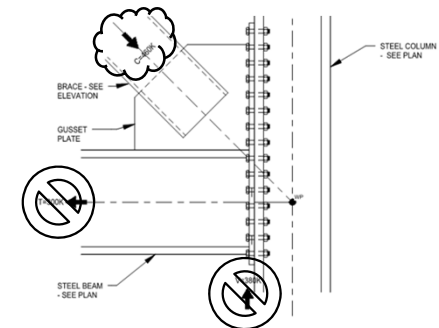

Tip#6: Clarify Moment Directionality

- Loads due to gravity only?
- Reversible loads?

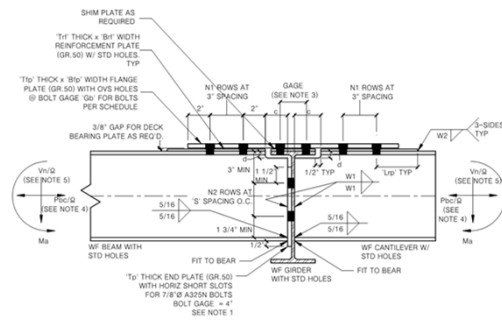

Tip#7: Moment Directionality

Moment Loads at Column: How much is transferred into the column?

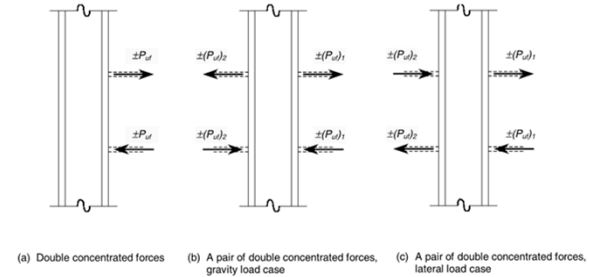

Tip#8: Panel Zone Information

AISC 360-10 Section J10.6

The nominal strength, R_n , shall be determined as follows:

(a) When the effect of panel-zone deformation on frame stability is not considered in the analysis:

(i) For $P_r \leq 0.4P_c$



$$R_n = 0.60F_y d_c t_w \quad (J10-9)$$

(ii) For $P_r > 0.4P_c$

$$R_n = 0.60F_y d_c t_w \left[1.4 - \frac{P_r}{P_c} \right] \quad (J10-10)$$

Tip#9: Specifying Axial Loads

Provide clear load path

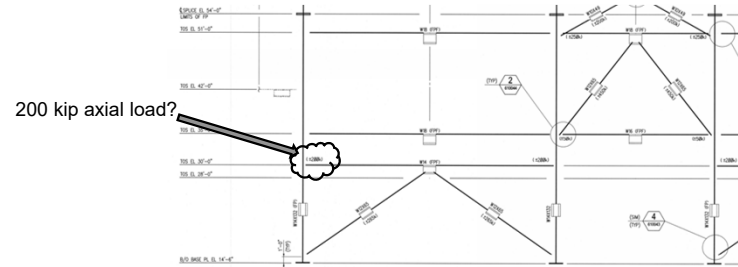

Tip#9: Specifying Axial Loads

Provide clear load path

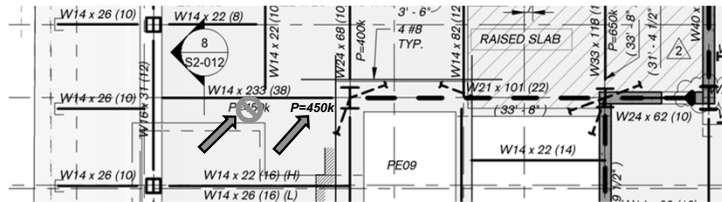

Tip#10: Provide Clear and Precise Architectural and Dimensional Restraints

- If critical, provide direction on connection size limitations.
- Examples:
 - Column wraps
 - MEP Coordination
 - Ceiling/wall clearances

Tip#10: Provide Clear and Precise Architectural and Dimensional Restraints

- No Typical Chevron Detail Provided on Design Documents

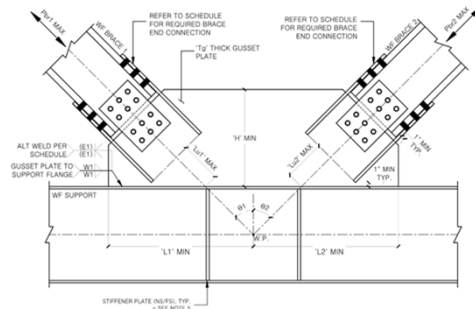

Tip#10: Provide Clear and Precise Architectural and Dimensional Restraints

- Getting Better!

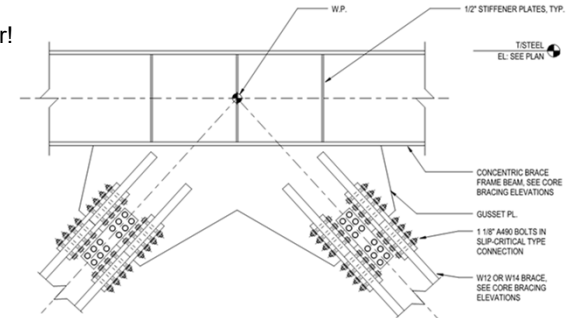

Tip#10: Provide Clear and Precise Architectural and Dimensional Restraints

- Clear direction finally provided!

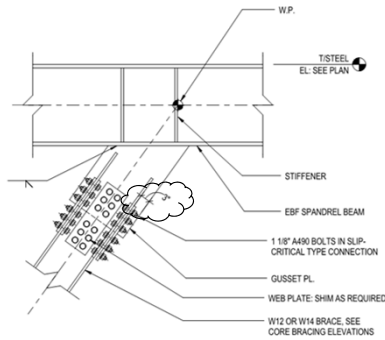

Tip#11: Focus on Expansion and Slip Joints

- Careful consideration of performance of expansion and slide bearing joints is needed.
- Accurately portray expansion requirements.
- What are movement requirements?

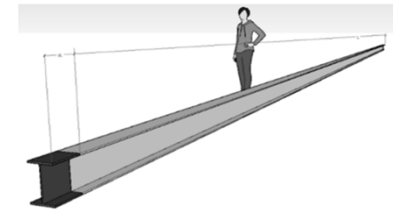

Tip#11: Focus on Expansion and Slip Joints

- Example

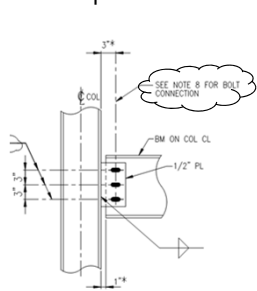

8. THE CONNECTION SHALL BE $1\frac{1}{16}'' \times 1\frac{7}{8}''$ LONG SLOTTED HOLES IN BEAM WEB FOR $\frac{3}{4}''$ A325 BOLTS (FULLY THREADED) WITH TWO NUTS EACH. CONNECTION SHALL BE BEARING-TYPE, BOLTS SHALL BE HAND TIGHTENED. (NUTS SHALL BE JAMMED TO PROVIDE $\frac{1}{16}''$ CLEARANCE BETWEEN NUT AND CONNECTION MEMBER) (SLIDING CONNECTION)

- Perfect Placement Results in $\frac{9}{16}''$ of movement in the joint.

Tip#11: Focus on Expansion and Slip Joints

- Consider erection tolerances
- Understanding of Installation temperature
- Understand distance between expansion joints



Tip#11: Focus on Expansion and Slip Joints

- Lack of 'attention to detail' led to connection failure.
- Connections were replaced on site.



Tip#12: Avoid Specifying SC(B) Connections

- Not all shops are set up to blast.
- Provide fabricator with flexibility to commercial blast steel.
- SSPC-SP6 versus SSPC-SP2

Tip#13: Avoid Requiring Field Welds

- Provide Fabricator and Erector flexibility.
- Field welding could be more than 2x costly than shop welds
- Location, Location, Location



Tip#14: Keep Welds to a Single Pass

- Welds up to 5/16" thick can be made using a single pass.
- Design welds for loads, avoiding large minimums.
- AISC 14th Edition Manual Table 8-12.

| | |
|------|---|
| 5/16 | 1 |
| 5/8 | 6 |

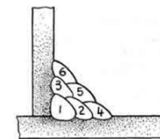

Table 8-12
Approximate Number of Passes for Welds

| Weld Size* in. | Fillet Welds | Single-Bead Groove Welds (Back-Up Weld Not Included) | | | Single-V Groove Welds (Back-Up Weld Not Included) | | |
|-------------------|-----------------|---|--------------|--------------------|--|--------------------|--|
| | | 30 Beevel | 45 Beevel | 30 Groove Angle | 45 Groove Angle | 60 Groove Angle | |
| 1/8 | 1 | 1 | 1 | 2 | 3 | 3 | |
| 1/4 | 1 | 1 | 1 | 2 | 3 | 3 | |
| 3/8 | 2 | 2 | 2 | 3 | 4 | 4 | |
| 1/2 | 3 | 3 | 3 | 4 | 5 | 5 | |
| 5/8 | 4 | 4 | 4 | 5 | 6 | 6 | |
| 3/4 | 5 | 5 | 5 | 6 | 7 | 7 | |
| 7/8 | 6 | 6 | 6 | 7 | 8 | 8 | |
| 1 | 7 | 7 | 7 | 8 | 9 | 9 | |
| 1 1/8 | 8 | 8 | 8 | 9 | 10 | 10 | |
| 1 1/4 | 9 | 9 | 9 | 10 | 11 | 11 | |
| 1 1/2 | 10 | 10 | 10 | 11 | 12 | 12 | |
| 1 3/4 | 11 | 11 | 11 | 12 | 13 | 13 | |
| 1 7/8 | 12 | 12 | 12 | 13 | 14 | 14 | |
| 2 | 13 | 13 | 13 | 14 | 15 | 15 | |
| 2 1/4 | 14 | 14 | 14 | 15 | 16 | 16 | |
| 2 1/2 | 15 | 15 | 15 | 16 | 17 | 17 | |
| 2 3/4 | 16 | 16 | 16 | 17 | 18 | 18 | |
| 3 | 17 | 17 | 17 | 18 | 19 | 19 | |
| 3 1/4 | 18 | 18 | 18 | 19 | 20 | 20 | |
| 3 1/2 | 19 | 19 | 19 | 20 | 21 | 21 | |
| 3 3/4 | 20 | 20 | 20 | 21 | 22 | 22 | |
| 4 | 21 | 21 | 21 | 22 | 23 | 23 | |
| 4 1/4 | 22 | 22 | 22 | 23 | 24 | 24 | |
| 4 1/2 | 23 | 23 | 23 | 24 | 25 | 25 | |
| 4 3/4 | 24 | 24 | 24 | 25 | 26 | 26 | |
| 5 | 25 | 25 | 25 | 26 | 27 | 27 | |

*Plate thicknesses for groove welds.

Tip#15: Size HSS Columns to Resist Connection Forces

- When practical select HSS thickness to resist connection forces.

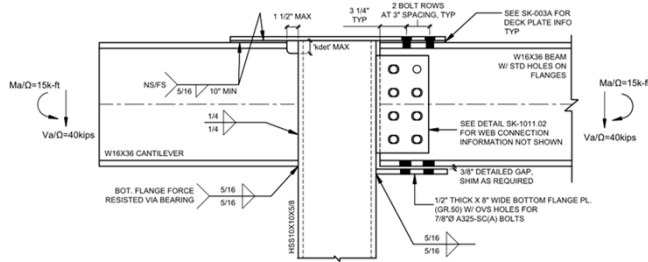

Tip#15: Size HSS Columns to Resist Connection Forces

- Connection costs can be significant if HSS columns are not sized properly.

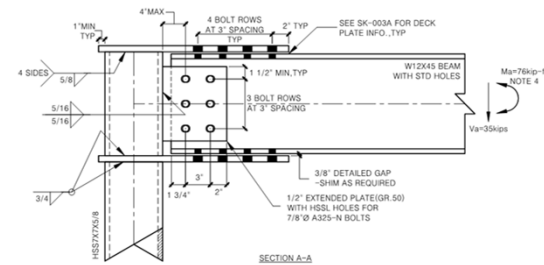

Tip#16: Value Engineering Opportunities

- Fabricator preferences
- Constructability
- Sequencing and schedule impact
- Crane considerations



Be flexible and open to suggestions.

Tip#16: Value Engineering Opportunities

- High Rise Case Study
- EOR provided blend of Option #01 and #03.
- EOR provided truss connections.
- Partially connected model

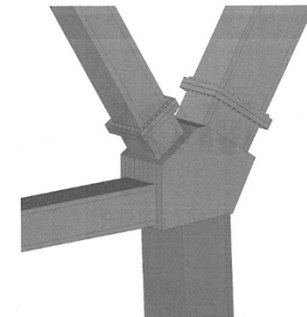

About 340 total connections similar were provided similar to as shown!

Tip#16: Value Engineering Opportunities

- 3rd Party Consultant hired by EOR.
- Provided alternative connection at bid time.
- Two Options Benefits the owner.

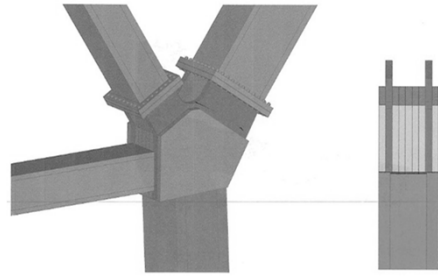

Options are great, but is it good enough?

Tip#16: Value Engineering Opportunities

- MBJ was hired by fabricator to provide 3rd Alternative.
- Solution was a lighter, more Fabricator friendly connection.
- Customized for Fabricator preferences.

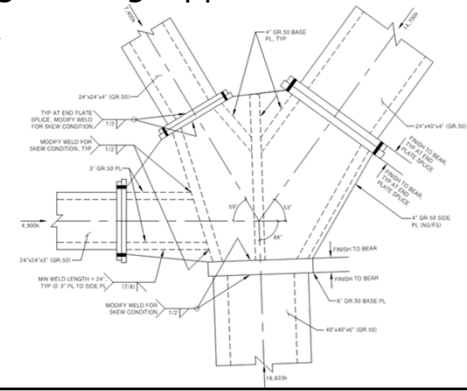

Alternative design was expected to save the project 4-5 million dollars!

Summary of Delegating Connections

If you take 3 things from this presentation today, remember these:

1. **Clear communication of delegated design requirements**
2. **Provide reasonable design requirements and loads**
3. **Provide fabricator with connection configuration options**

MEYER | BORGMAN | JOHNSON
STRUCTURAL DESIGN + ENGINEERING

Delegated Connection Design Questions?

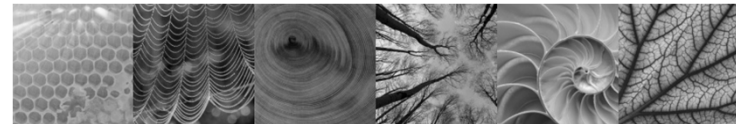

Visit our web site at www.mbjeng.com

SEE STRUCTURE.

MEYER | BORGMAN | JOHNSON
 STRUCTURAL DESIGN + ENGINEERING

Part 2: Delegated Design for Cold Formed Metal Framing

Presented by:
 Lindsey Schultz, SE (AZ),
 Structural Engineer and Office Leader of Arizona Office

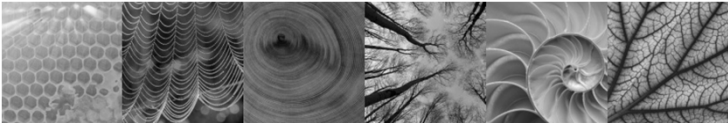

Visit our web site at www.mbjeng.com SEE STRUCTURE.

Part 2: Delegated Design for Cold-Formed Steel Framing Outline

- Code of Standard Practice Requirements and Other Resources
- Benefits and Challenges for CFS as a Deferred Submittal
- Recommendations for Construction Documents and Specifications
- CFS Framing Trends
- Common Coordination Challenges
- Project Example / Case Study

Poll The Audience



Poll The Audience

- AISI Code of Standard Practice for the Cold-Formed Steel Structural Framing
- Definitions
 - *Building Designer – Owner of the building or the person that contracts with the owner for the design of the framing structural system or who is responsible for the preparation of the construction documents. When mandated by the legal requirements, the building designer shall be a registered design professional.*
 - *Specialty Designer – The registered design professional, individual or organization having responsibility for the design of the specialty items. The requirement for a Specialty Designer is typically called out in the specifications or structural general notes. The Specialty Designer is typically not the building designer.*



Poll The Audience



- AISI Code of Standard Practice for the Cold-Formed Steel Structural Framing
 - Types of CFS Construction
 - Façade Framing
 - Metal Buildings
 - Concrete/Steel Frames
 - Metal Deck
 - Trusses
 - Other Uses
 - Solar
 - Manufacturing

Code of Standard Practice Requirements



- AISI Code of Standard Practice for the Cold-Formed Steel Structural Framing
 - Section A4 Responsibility for Design
 - Section C1 Responsibilities for Construction Documents
 - Section D Installation Drawings

Code of Standard Practice Requirements



- AISI Code of Standard Practice for the Cold-Formed Steel Structural Framing
- Responsibility for Design
 - A4.1 Building Designer and Specialty Designer
 - A4.2 Construction Documents
 - A4.3 Owner
 - A4.4 Contractor and Sub-Contractor

Code of Standard Practice Requirements

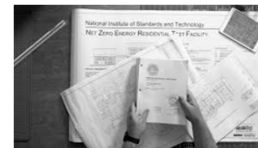

- AISI Code of Standard Practice for the Cold-Formed Steel Structural Framing
 - Section C1 Construction Document Responsibilities
 - Documents shall show type of support supplied, method of attachment, correct dimensions, and required min or max sizes and spacings.
 - If Deferred submittal, specialty designer shall provide above noted information to EOR for review and approval.
 - Architectural plans shall indicate the design intent of the CFS structural framing.
 - Structural plans shall show the structural member locations, sizes, reinforcing and connections in sufficient scale and detail to enable to the construction of the building in a reasonable sequence.

Code of Standard Practice Requirements

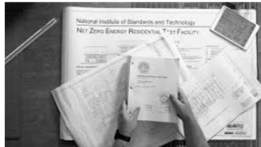

- AISI Code of Standard Practice for the Cold-Formed Steel Structural Framing
- Installation Drawings
 - Section D1 Owner/Contractor Responsibility
 - Section D2 Component Manufacturer Responsibility
 - Section D3 Review Process
 - Section D4 General Responsibility

Cold-Formed Steel Resources

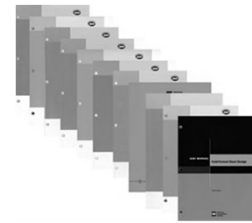

- AISI Codes – North American Standards for Cold-formed Steel Framing – IBC 2012
- AISI S200 – General Provisions
 - Provides basic information about installation tolerances, member design, connections and other basics for using and installing steel framing for construction
- AISI S100 – Specification for Design
 - This contains the equations for design of members. It applies not only to steel members, but to all thin and cold-formed steels used in construction

Cold-Formed Steel Resources



- AISI Codes – North American Standards for Cold-formed Steel Framing – IBC 2012
- AISI S212 – Header Design
 - Provides guidance for the design of three types of headers: boxed C-shapes, back-to-back C-shapes, and double “L” headers.
- AISI S211 – Wall Stud Design
 - Provides additional guidance for design of wall systems, in both loadbearing and nonloadbearing applications

Cold-Formed Steel Resources

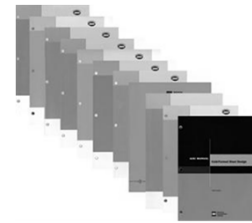

- AISI Codes – North American Standards for Cold-formed Steel Framing – IBC 2012
- AISI S214 – Truss Design
 - Gives design information for truss design responsibilities, loading, design criteria, quality criteria, installation, bracing, and testing of trusses and truss systems.
- AISI S210 – Floor and Roof System Design
 - This standard is intended for the design and installation of cold-formed steel framing for floor and roof systems in buildings. The standard provides a methodology for continuously braced design. The standard also includes provisions for clip angle bearing stiffeners.

Cold-Formed Steel Resources



- AISI Codes – North American Standards for Cold-formed Steel Framing – IBC 2012
- AISI S213 – Lateral Design
 - This standard addresses the design of lateral force resisting systems to resist wind and seismic forces in a wide range of buildings constructed with cold-formed steel framing. It contains design requirements for shear walls, diagonal strap bracing and diaphragms.
- AISI S230 – Prescriptive Method for One- and Two-family Dwellings
 - This standard provides prescriptive requirements for cold-formed steel-framed detached one- and two-family dwellings, townhouses, attached multi-family dwellings, and other attached single-family dwellings. It includes numerous tables and details to allow buildings complying with the limitations therein to be constructed. Alternatively such dwellings may be designed by a design professional.

Cold-Formed Steel Resources

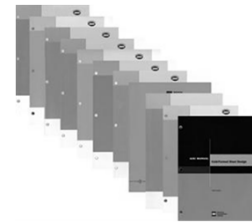

- AISI Codes – North American Standards for Cold-formed Steel Framing – Additional Standards
- AISI S202 - Code of Standard Practice
- AISI S220 - Nonstructural Members
- AISI S400 - Seismic Design
- AISI S240 – Structural Framing

Cold-Formed Steel Resources



- Cold-Formed Steel Engineers Institute (CFSEI)
- AISI Codes
- Various Design Guides Available



- Steel Stud Manufacturers Association (SSMA)
- Steel Stud Properties
- Load-Span Tables

Cold-Formed Steel Resources

• Software

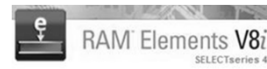

Why do Cold-Formed Metal Framing as a Deferred Submittal?

- PROS
- More flexibility for installer
- Efficient designs by specialty designer
- Knowledge of availability for procurement
- Coordination with construction sequence



Why do Cold-Formed Metal Framing as a Deferred Submittal?

- CHALLENGES
- Construction Schedule
- Load Path Verification



Why do Cold-Formed Metal Framing as a Deferred Submittal?



Recommendations for Construction Documents and Specifications

- General Structural Notes
- Deferred Submittal
- Applicable Building Codes
- Aligned with Specifications

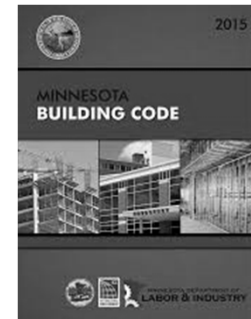

Recommendations for Construction Documents and Specifications

- Structural Drawings
- Structural Member Locations and Sizes
- CFS Connections in sufficient detail to enable construction of the building in a reasonable sequence
- Aligned with Specifications

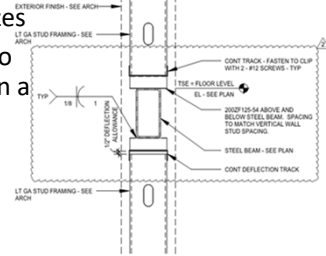

Recommendations for Construction Documents and Specifications

- Architectural Drawings
- Design Intent
- Member size constraints
- Location within the structure
- Dimensions
- Aligned with Specifications

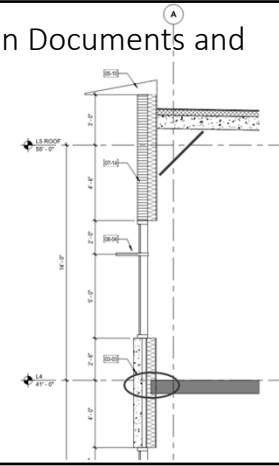

Recommendations for Construction Documents and Specifications

- Specifications 05 40 00
- Design Criteria and Responsibilities
- Member Size and Connection Criteria
- Performance Requirements
- Aligned with Drawings



Recommendations for Construction Documents and Specifications

- Specifications 05 40 00
- General
 - Performance Requirements
 - Design Responsibilities
- Products
- Execution



CFS Framing Trends

- The Labor Shortage



CFS Framing Trends

- Pre-fabrication and Modularization



CFS Framing Trends

- Alternate Member Configurations

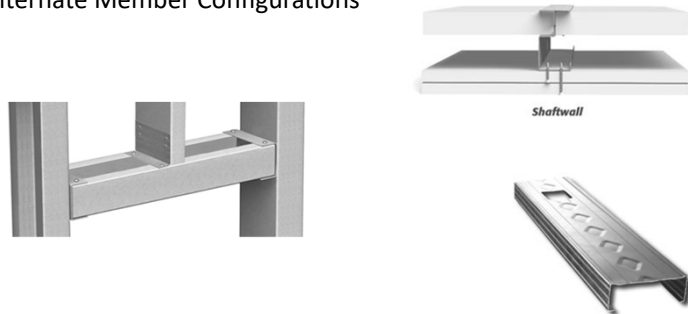

CFS Framing Trends

- Connections – Manufactured Clips vs. Field Fabricated

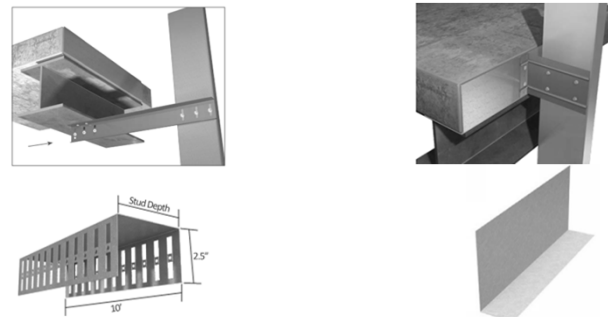

CFS Framing Trends

- Performance Requirements
- Deflection Criteria per IBC
 - L/180 – Interior walls and partitions
 - L/360 – Exterior walls with plaster or stucco
 - L/240 – Exterior walls with brittle finishes
 - L/120 – Exterior walls with flexible finishes
 - L/180 – Exterior walls with gypsum board interior finish
- 2018 IBC
 - L/175 for walls supporting glass less than 13'-6" and L/240 + 1/4" for spans greater than 13'-6"
- Brick Industry Association
 - L/600 – Brick walls

CFS Framing Trends

- Performance Requirements
- Energy Efficiency



Common Coordination Challenges

- Continuous Ribbon Windows
- Coordinate Kicker locations with other disciplines
- Coordinate Slab edge
 - A bypass condition is preferred by framer
 - Precast loads on steel studs and slab edge

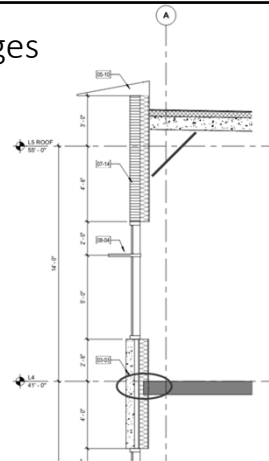

Common Coordination Challenges

- Fire-Proofing Coordination
- Spray on Fire-proofing

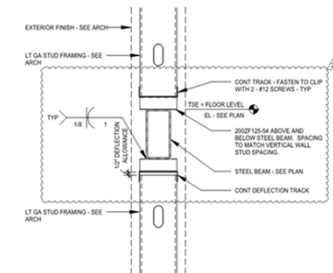

Common Coordination Challenges

- Construction Sequencing
- Alternate Bypass Conditions

The Steel Network, Inc. **TSN**
www.steelnetwork.com
1-888-474-4876

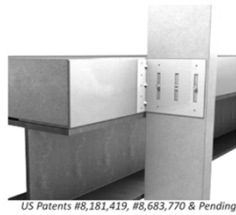

The Steel Network, Inc. **TSN**
www.steelnetwork.com
1-888-474-4876

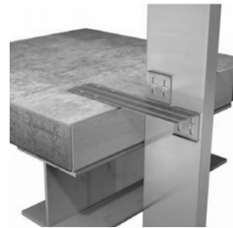

Common Coordination Challenges

- Construction Sequencing
- Splice Locations
 - CFSEI TN W106 Design for Splicing of Cold-Formed Steel Wall Studs

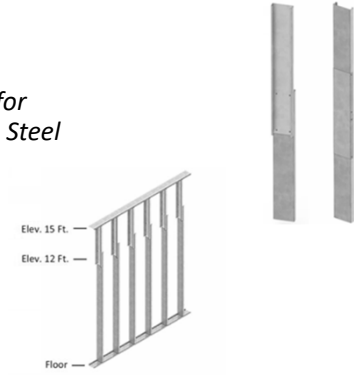

Common Coordination Challenges

- Damaged Studs
- Web Holes
- Coped Flanges
- Punch location



Biosciences Partnership Building

- University of Arizona Biosciences Partnership Building



Biosciences Partnership Building

- Design Team
- Architect – CO Architects and Ayers Saint Gross
- Structural EOR – Martin & White
- GC – DPR
- Cold-Formed Steel Sub-contractor - DPR
- Specialty Designer - MBI

Biosciences Partnership Building

- University of Arizona Biosciences Partnership Building
- 10-story research building is LEED Silver certified
- Copper Panel façade
 - Sunscreen
 - Panels with 2" air space, rigid insulation and waterproofing membrane



Biosciences Partnership Building

- Prefabricated Panels
- Copper Panel façade
 - 24 copper panels

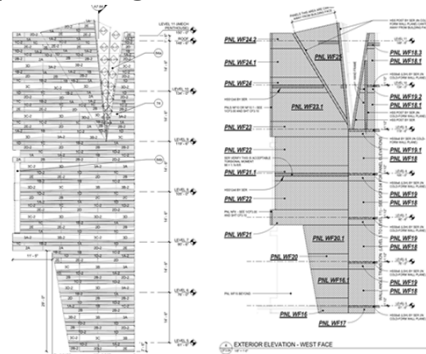
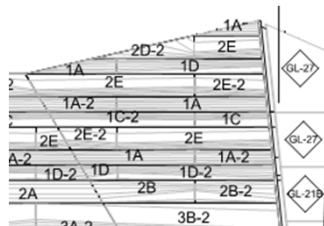

Biosciences Partnership Building

- Embed Coordination and Reactions at Structure

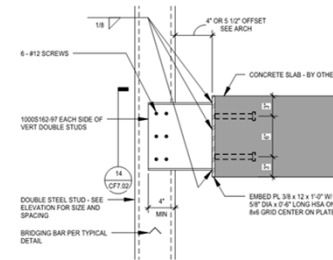

Biosciences Partnership Building

- Supplemental Steel

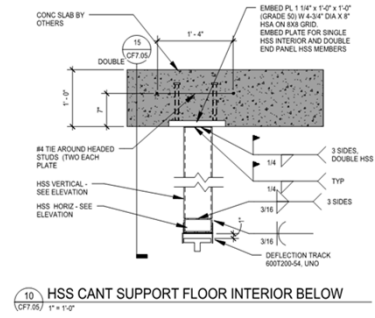
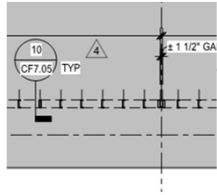

MEYER | BORGMAN | JOHNSON

STRUCTURAL DESIGN + ENGINEERING

COLD FORMED METAL FRAMING QUESTIONS?

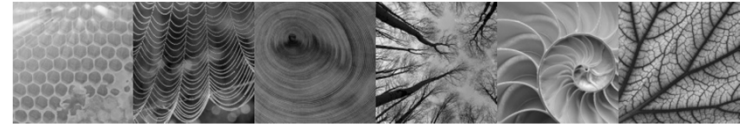

Visit our web site at www.mbjeng.com

SEE STRUCTURE.