

# DeltaV™ IS Electronic Marshalling

- Intrinsically Safe I/O anywhere you need it
- Integrated galvanic Isolation per channel
- Reduces installed cost of system
- Fully redundant architecture
- Field mounted capable hardware
- Plug and play I/O



The DeltaV™ CHARM I/O Card (CIOC) with IS CHARMs.

## Introduction

DeltaV™ IS Electronic Marshalling delivers a new level of control system I/O performance with unprecedented flexibility and ease of use. The addition of Intrinsically Safe (IS) CHARMs provides significant savings in system design, installation cost and ease of maintenance expected with Electronic Marshalling, with the added safety for field wiring to hazardous areas. The reduced footprint and associated elimination of separate barriers and the associated inter cabinet wiring makes for a more robust installation with significant cost savings.

## Benefits

**Intrinsically Safe I/O anywhere you need it:** DeltaV CHARM I/O Card (CIOC) supports both conventional and IS CHARMs, providing an unprecedented flexibility in control system I/O topology. Using standard Ethernet infrastructure hardware you can add I/O anywhere you need it. From a local I/O cabinet to remote enclosures miles away, simply install the hardware and connect it to the DeltaV control network. Each I/O card can serve I/O signals to any of four controllers in the system with 50 ms updates for fast, reliable control.

**Integrated galvanic isolation per channel:** Each I/O channel has a dedicated IS CHARM that provides both signal characterization and galvanic isolation for intrinsically safe applications. IS barriers are integrated inside the IS CHARM to provide single channel fault isolation as well as electrical isolation and energy limiting circuitry that meets IEC Ex ia ratings.

**Reduces installed cost of system:** DeltaV Electronic Marshalling helps reduce overall system cost by eliminating internal cabinet cross wiring, reducing overall footprint, simplifying I/O channel assignments, and reducing FAT activities. Electronic Marshalling provides separation between I&E hardware installation schedules and control strategy development. Wiring can begin earlier knowing any late changes can be done without lifting a wire. Separation of the controller and I/O allows more efficient cabinet designs and accommodates late scope changes by adding I/O anywhere. Adding additional control capacity does not require re-wiring I/O. Simply assign the control modules and their I/O signals to the new controller, without lifting a wire.

**Fully redundant communications:** The CIOC architecture is fully redundant. This starts with the two I/O cards on the carrier. The carrier has redundant communication modules for primary and secondary network connections. There are two 24V DC input power connections. The carrier connects to the IS CHARMs baseplates and provides redundant power and communication buses to the CHARMs. Everything is redundant down to the individual channel.

**Field mounted capable hardware:** All components of the CIOC are rated for installation in Class 1/Div 2 or Zone 2 hazardous locations. The extended operating temperature ranges and G3 environment rating allows them to be installed in field mounted junction boxes. This further reduces the foot print required in central equipment rooms, as well as reduces the overall wiring infrastructure of traditional multi-core instrumentation cable.

**Plug and Play I/O:** The DeltaV CIOC has been designed for ease of use, both in physical installation and its software tools. Components snap together with secure DIN-rail latches and interlocking carrier connectors.

Attach a series of 96 I/O channels to a DIN-rail in a matter of minutes. Insert the IS CHARMs and auto sense the node to create the I/O definition automatically in your DeltaV configuration database. IS CHARMs using a self-keying system to automatically set a channel for a specific IS CHARM type. Users cannot mistakenly insert an IS CHARM into the wrong terminal block. Assign all, one or any number of channels to a controller with a simple click or drag and drop.



IS CHARM and Terminal Block.

Field power is provided through a redundant 24V DC bus to each IS CHARM. Each IS CHARM provides galvanically isolated field power through an internal isolation transformer, eliminating external wiring to barriers.

## Product Description

IS Electronic Marshalling hardware includes:

- CHARM I/O Carrier (DIN rail mounted and supports redundant pair of CHARM I/O Cards, redundant 24V DC power connectivity, and redundant Ethernet communication modules).
- CHARM I/O Card (CIOC) provides communication between CHARMs and the Ethernet I/O network to M-series, S-series, and PK controllers. The CIOC has Achilles Communications Certification Level 1 and the redesigned CIOC2 has more computing power and Achilles Communications Certification Level 2. The CIOC2 is a drop-in replacement for the CIOC (v14.3 or later is required).
- IS CHARM Baseplate (DIN rail mounted with interleaving power and bus connectors. Supports 12 IS CHARMs and their terminal blocks).
- IS CHARM Terminal Block (removable terminal block providing terminal connections to field wiring and physical latch for IS CHARM).
- IS CHARMs (Characterization Module for each field signal. Provides galvanic isolation, fault isolation and basic analog to digital conversion to the redundant communication bus).



CHARM I/O Card (CIOC) with IS CHARMs and Baseplate Separator in Place.

- Labeling features for baseplate and channel identification.
- Cable Extenders that provide flexibility in carrier mounting.
- I/O bus termination (provides bus terminations for redundant I/O bus).

Intrinsically Safe CHARMs are designed to meet IEC EX ia level of safety and are suitable for connecting to field devices installed in Class 1 Division 1 Hazardous Locations or Zone 1/0 Hazardous Areas. The CHARM I/O Card and IS CHARMs are rated for installation in a Class 1 Division 2 Hazardous location, a Zone 2 hazardous area or in the safe area.

The CHARM I/O card carrier is mounted to the top of a vertical DIN rail and up to eight CHARM Baseplates are mounted below it. IS CHARM Baseplates and regular CHARM Baseplates can be combined on the same CIOC, provided installation rules are respected. The baseplates snap easily to the DIN rail as they are connected to each other. The bus termination assembly is attached at the bottom. A standard DIN-rail lock is used to keep the entire assembly in place.

Each IS baseplate is ordered pre-loaded with 12 IS terminal blocks that are ready to receive field wires from 2, 3 and 4-wire devices. Electronic Marshalling eliminates the need to scramble the field wiring or to partition the I/O to match signals to channel types of specific cards. Simply connect field signal multi-cores in an orderly fashion as desired. Insert the appropriate IS CHARM into each terminal block to complete the field circuit and the signal is ready to be used by any one of 4 controllers. No cross-wiring required.

All IS CHARMs are energy limited devices that prevent the possibility of an explosion, even if wires are accidentally shorted together. In addition, each IS CHARM acts as a circuit protection device and field wiring disconnect. Each IS CHARM provides surge protection to meet industry standards in the area of EMC. Under extreme over voltage conditions due to incorrect field wiring, the IS CHARM will act as a fuse to protect adjacent channels. Signal faults are thus isolated to the single IS CHARM.

IS CHARMS can be partially ejected to a locked position that disconnects the field wiring from the system to perform field maintenance actions or to remove power to a field device.

Activating the IS CHARM latch ejects the IS CHARM to the detent position. Closing the latch locks the IS CHARM in place and isolates the field wiring for field work.



*IS CHARM Latch Mechanism.*

The CIOC communicates over a redundant Ethernet network with up to 4 controllers, allowing great flexibility and ease of system expansion. Additional controllers can be added to accommodate increased control scope and I/O can be reassigned without changing the physical wiring.

IS CHARMs can be added to any existing IS baseplate position and autosensed online. Additional CIOC's can be added online.

### IS CHARM Types

A variety of analog and discrete IS CHARMs are available to meet your specific requirements. The following IS CHARMs are available starting with v11.3.1:

- IS AI 4-20 mA HART
- IS RTD
- IS Thermocouple / mV
- IS AO 4-20 mA HART
- IS DI NAMUR
- IS DO 45 mA

All IS CHARMs have a bi-color Power/Integrity LED that indicates the health of the IS CHARM. The indications provide clear, actionable instruction to the maintenance personnel.

- Green Solid: Normal Operation
- Green Blink: Normal awaiting configuration
- Red Blink: Fault detected on wiring
- Red Solid: Internal Fault detected

Discrete IS CHARMs have a Yellow LED to indicate the state of the field signal.

All IS CHARMs meet ISA 71.04-1985 severity level G3 (harsh) corrosion specifications.

The IS DI NAMUR CHARM supports a pulse counter with a maximum frequency of 10 KHz.

## I/O Terminal Block Options

IS CHARMs are designed to work with the IS Terminal Blocks, which are light blue in color, designating the field wiring as intrinsically safe. IS CHARMs are mechanically different and will not install in non-IS terminal blocks, ensuring there is no error in the installation.

There are two different IS Terminal Blocks available to meet the wiring needs of field signals.

- IS Terminal Block
- IS Thermocouple/mV Terminal Block

The IS Terminal Block has 4 terminals, supporting the traditional discrete and analog 2 & 4 wire sensor/actor field instrumentation signals as well 2, 3 and 4 wire RTD Sensors

The IS Thermocouple / mV Terminal Block is specially designed for the usage with the IS Thermocouple / mV CHARM. The IS Thermocouple / mV Terminal Block and IS Thermocouple / mV CHARM can only be ordered as an Assembly.

## IS CHARM Keying Posts

The IS Terminal Blocks contain keying posts that are automatically set and locked to the unique position of the installed IS CHARM. The keys prevent the insertion of an incorrect IS CHARM during maintenance activities. The IS Terminal Blocks are shipped with the keys in a neutral position and are set when an IS CHARM is inserted. If needed, the keys can be manually reset to allow a channel to be re-tasked for a different signal type.

The keying mechanism consists of two keying posts that rotate and lock into the IS Terminal Block base. Each IS CHARM type is assigned a unique key setting.

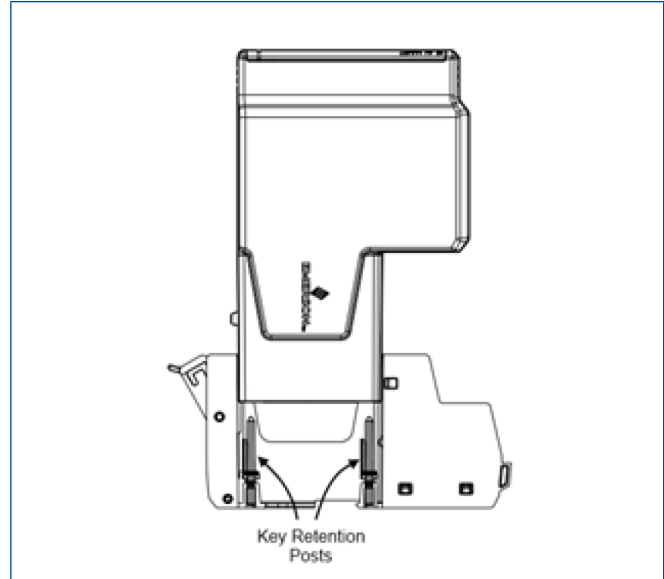

IS CHARM Terminal Block.

## IS CHARM Baseplates

IS CHARM baseplates are mechanically different than non-IS baseplates, ensuring there is no error in the installation of the Terminal Blocks or CHARMs (non-IS). A baseplate separator is needed on the beginning and on the end of any IS CHARM baseplate row, also in between any of the IS CHARM baseplates. You can add IS CHARM baseplates to non-IS CHARM baseplates and any of the other components, like the CIOC carrier, CHARM baseplate extenders and CHARM baseplate Terminators.

## ASCO Numatics 580 CHARM Node

The 580 CHARM node enables Easy solenoid valve integration into DeltaV with Electronic Marshalling. The new 580 CHARM node connects directly to the CIOC via redundant CHARM Baseplate extender cables. DeltaV can autosense the I/O as DO Solenoid Valve CHARMs the same way as any other CHARM is autosensed in DeltaV. The ASCO Numatics 580 CHARM node can be installed in Zone 2 hazardous areas and can be combined with the DeltaV IS Electronic Marshalling.



Benefits of the new 580 CHARM Node include:

- Redundant communications and power connections to pneumatic valve manifolds.
- Eliminates the need for additional dedicated networks like Profibus-DP and simplifies system I/O mapping.
- Expands the Electronic Marshalling I/O offering to include ASCO Numatics pilot valve manifolds, enhancing the concept of: "I/O Anywhere".
- Reduces programming and commissioning time dramatically.

## Hardware Specifications

Common Environmental Specifications (all components)	
Operating Temperature*	-40 to 70°C (-40 to 158°F)**
Storage Temperature	-40 to 85°C (-40 to 185°F)
Relative Humidity	5 to 95% , non-condensing
Protection Rating	IP 20
Airborne Contaminants	ISA-S71.04-1985 Airborne Contaminants Class G3 Conformal coating
Shock	10 g ½-sine wave for 11 ms
Vibration	1 mm peak-to-peak from 2 to 13.2 Hz; 0.7 g from 13.2 to 150 Hz

\*Operating any electronics at the higher end of its temperature range for long periods of time will shorten its expected lifetime, see **Effects of Heat and Airflow Inside an Enclosure White Paper** for more information.

\*\*When used with copper Ethernet I/O Ports (Copper IOP). When used with the Fiber Optic I/O Ports (Fiber Optic IOP), the operating temperature range is limited to -40 to 60°C (-40 to 140°F).

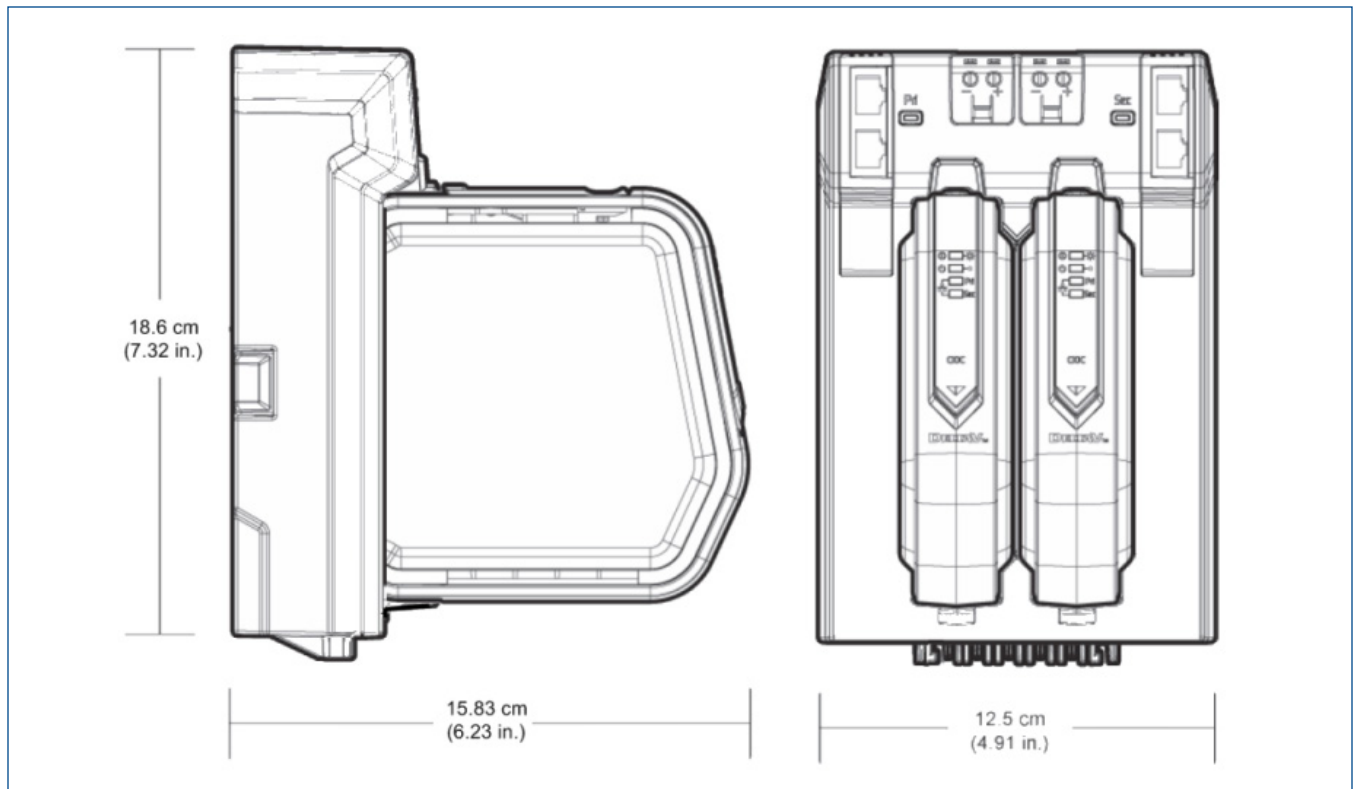

CHARM I/O Card and Carrier.

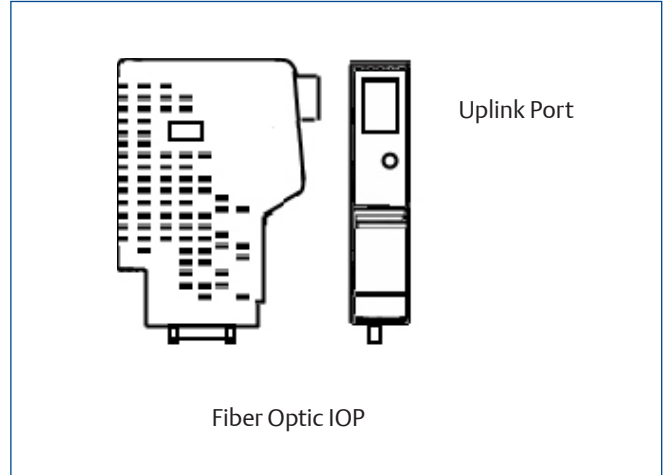
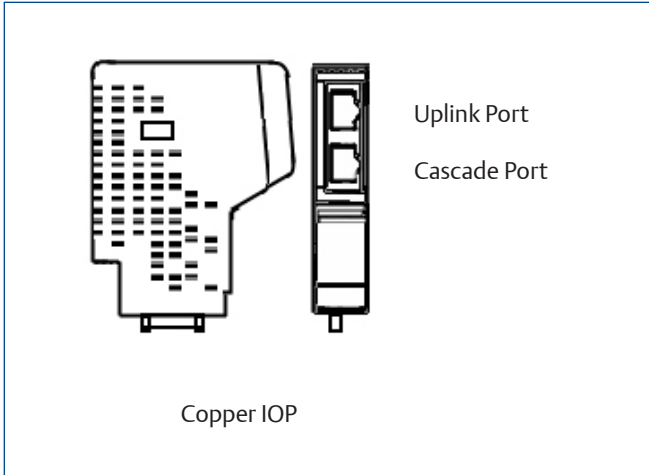

Operating Temperature -40 to 70°C (-40 to 158°F).

Operating Temperature -40 to 60°C (-40 to 140°F).

CIOC Carrier Ethernet Communication Modules

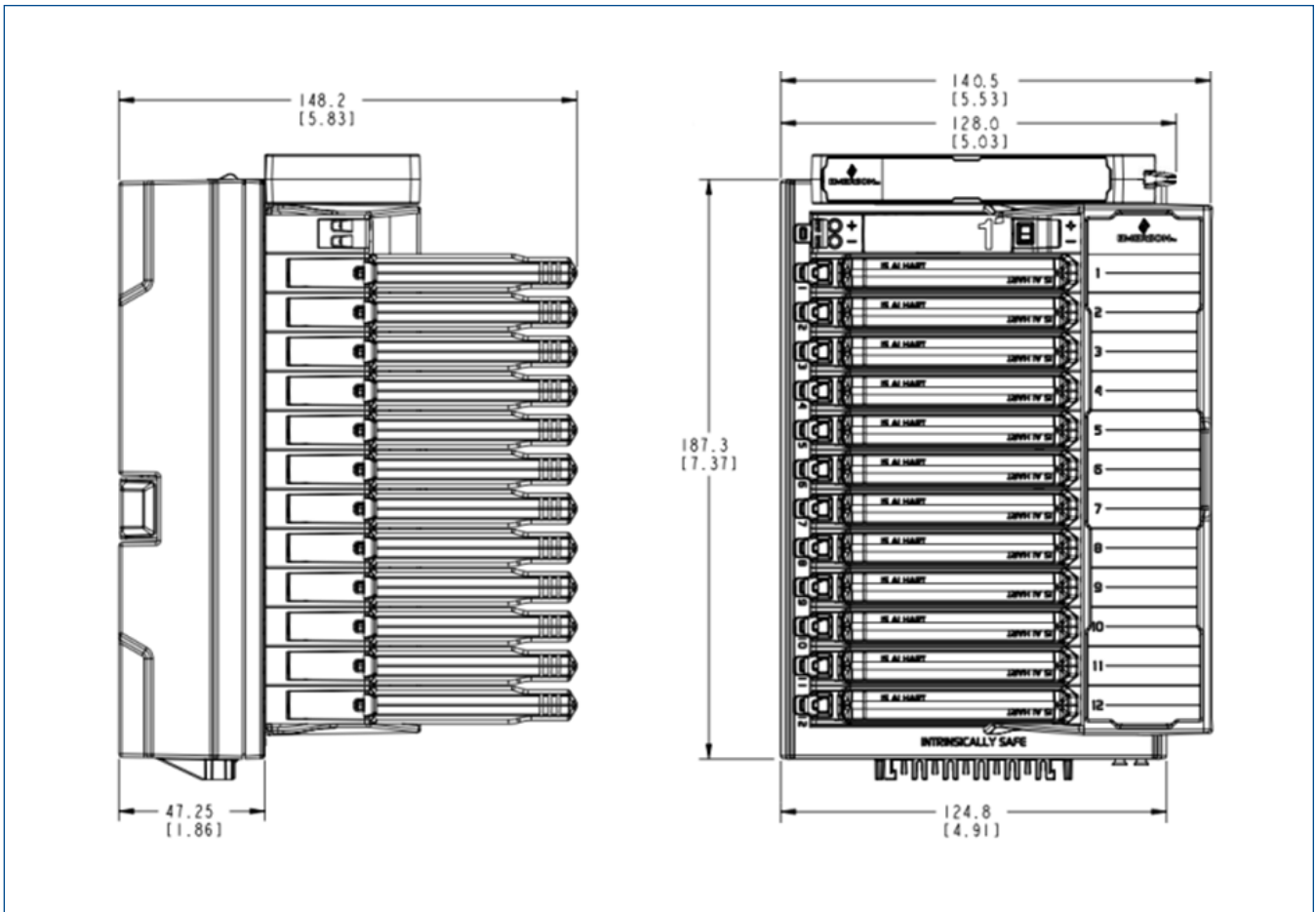

IS CHARM Baseplate with Separator, IS CHARMs and Label Plates in Place.

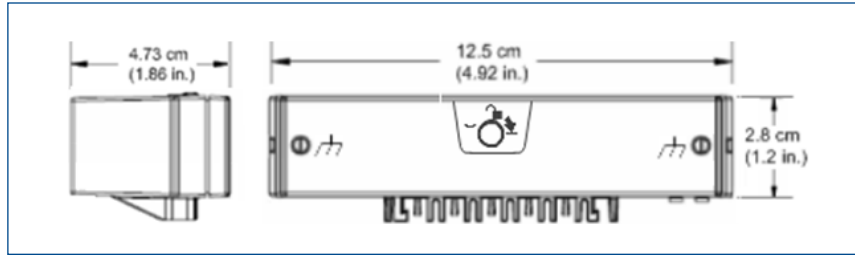

CHARM Baseplate Terminator, Top.

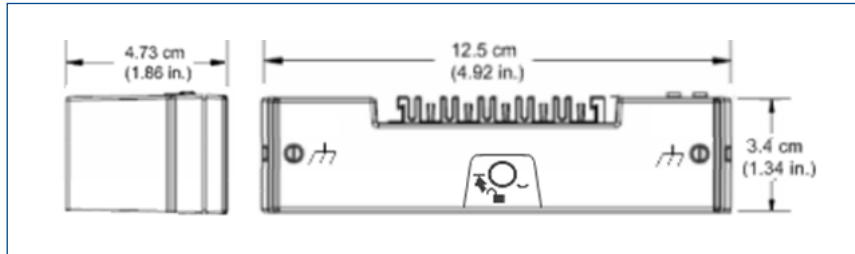

CHARM Baseplate Terminator, Bottom.

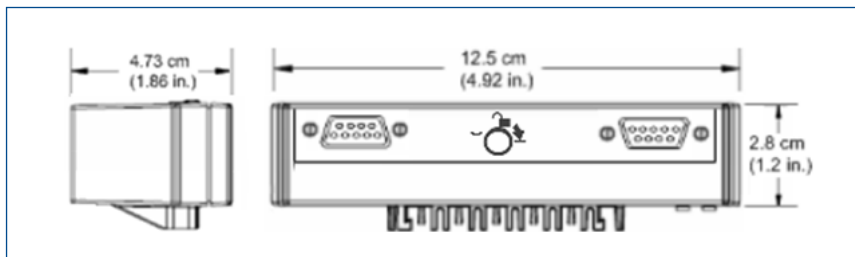

CHARM Baseplate Extender, Top.

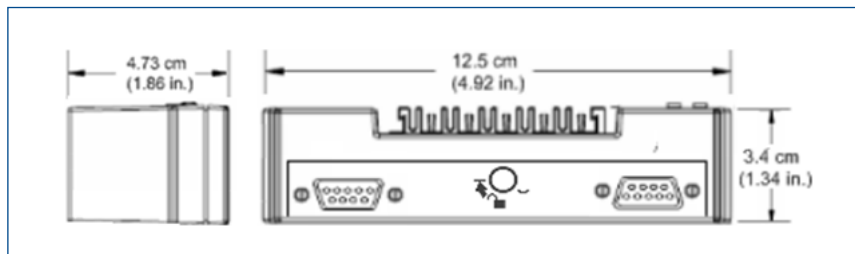

CHARM Baseplate Extender, Bottom.



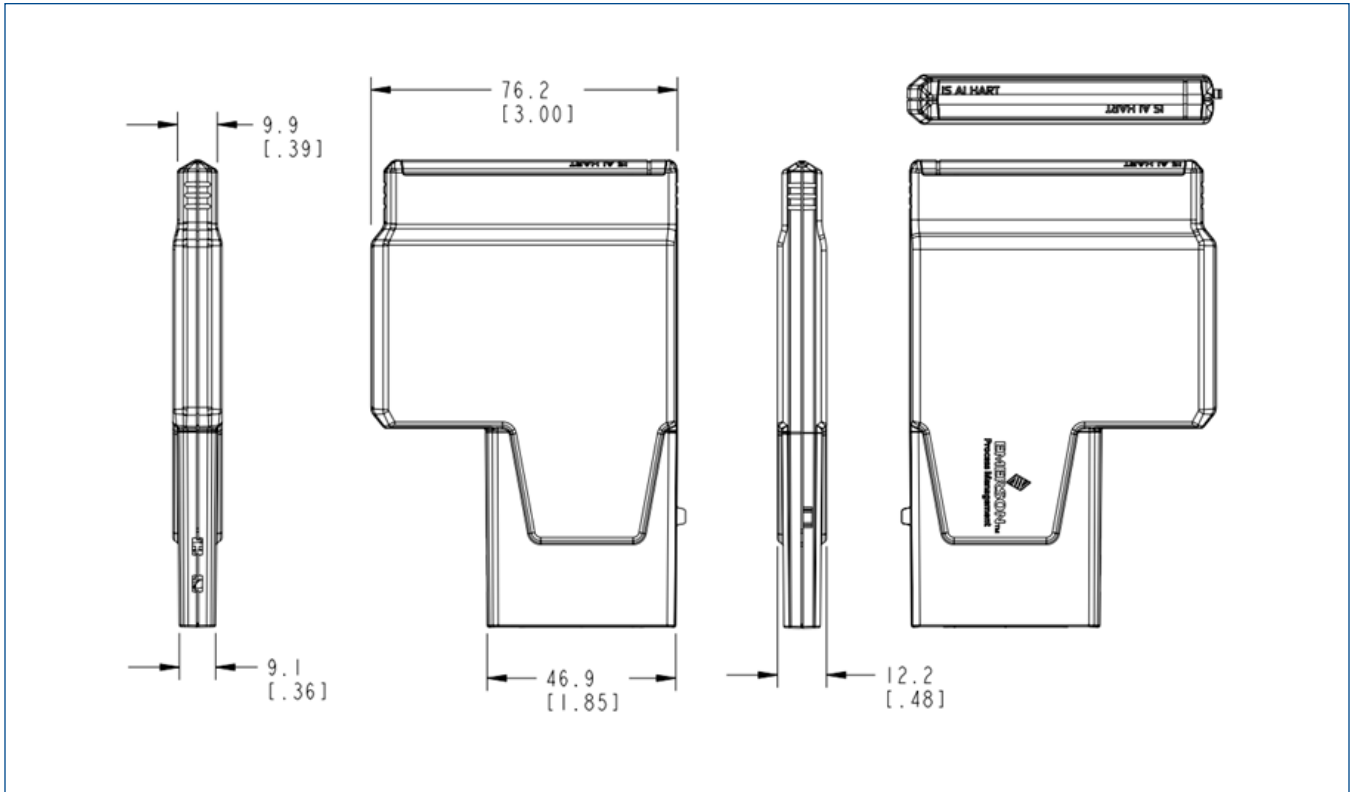

IS CHARM.

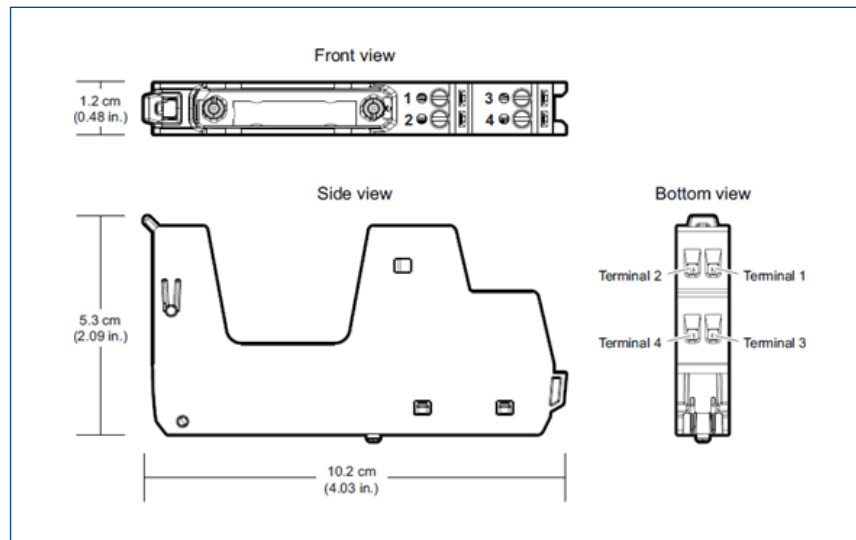

IS CHARM Terminal Block.



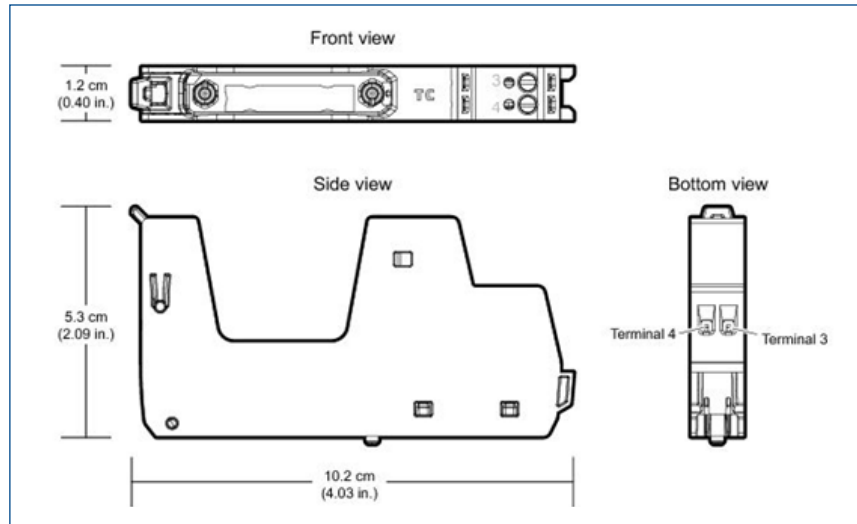

IS CHARM Thermocouple/mV Terminal Block.

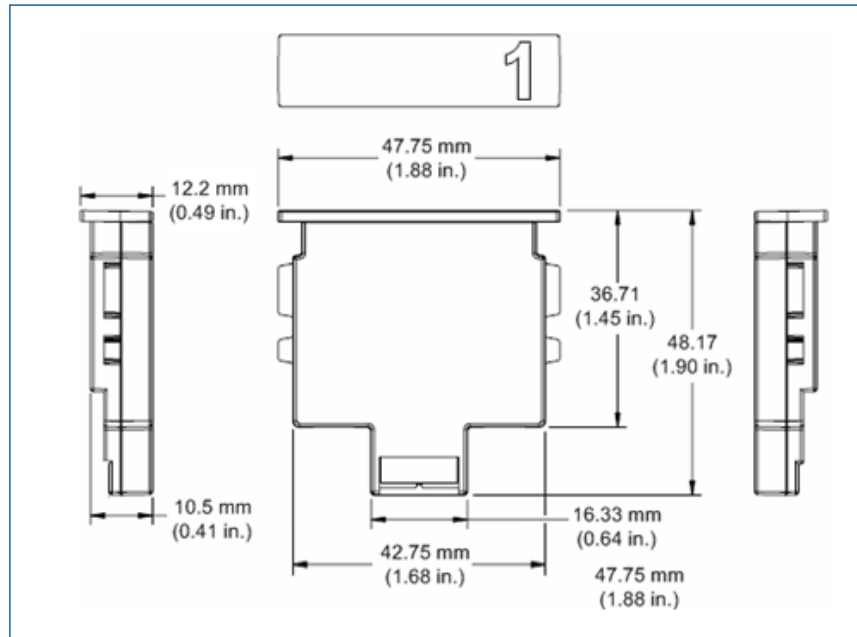

Address Plug.

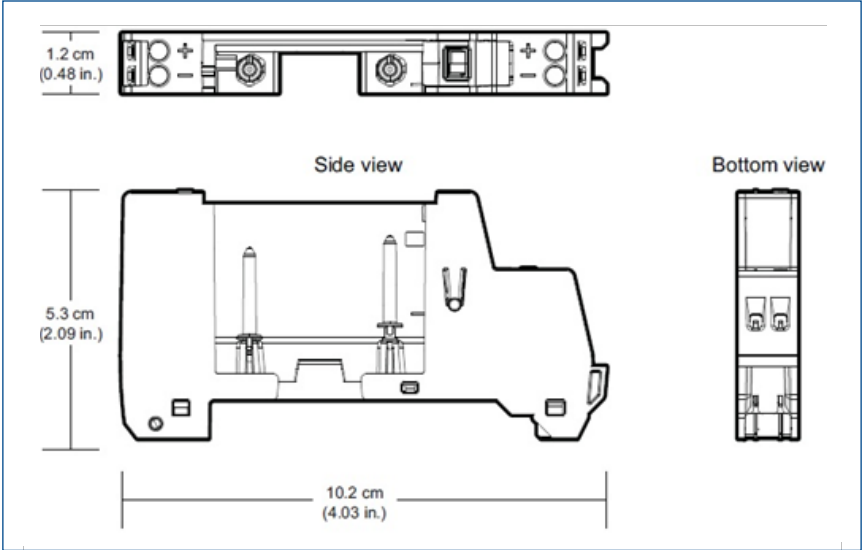

Address Plug Terminal Block for IS Baseplate.

## CHARM I/O Card Hardware

Specifications for CHARM I/O Card Carrier	
Number of I/O Cards per Carrier	2 (redundant pair)
Input Power (Redundant)	24V DC $\pm$ 10% at 12 A maximum
Redundant Ethernet Connections	Fiber-optic: <ul style="list-style-type: none"> <li>■ 100BASE-FX with MTRJ connectors</li> <li>■ Full duplex operation</li> <li>■ Multi-mode - 2 km nominal distance</li> </ul> Copper twisted pair: <ul style="list-style-type: none"> <li>■ 10/100BASE-TX with RJ45 connectors</li> <li>■ Half/Full duplex operation</li> <li>■ 100 m distance</li> </ul>
Mounting	DIN rail Latch to T-type rail
Specifications for CHARM I/O Card (CIOC) and CHARM I/O Card 2 (CIOC2)	
Number of I/O Channels	96 Channels, individually defined signal types
Number of I/O Clients	4 (Controllers)
Number of CIOC's per Controller	16
Number of CIOC's per System	300
I/O Update Rates	50ms, 100ms, 250ms, 500ms
User Memory	N/A
CIOC Power (24V DC)	0.28A per redundant CIOC node 0.32A per redundant CIOC2 node (includes two cards and two communication modules) (individual CHARM power requirements are in addition)
CIOC Heat Dissipation	8 Watts max. per redundant CIOC node 9 Watts max. per redundant CIOC2 node <ul style="list-style-type: none"> <li>■ 2.0 Watts per CIOC</li> <li>■ 2.5 Watts per CIOC2</li> <li>■ 1.34 Watts per Copper Ethernet I/O Communication Port</li> <li>■ 2.0 Watts per Fiberoptic I/O Communication Port</li> </ul>
CIOC Output to CHARMs	6.3V DC redundant power, at 3.25 A maximum*
Fuse Protection (Internal)	Internal Non-replaceable Fuse
Mounting	2-wide CHARM I/O Carrier
Communication	Redundant Ethernet connections via CHARM I/O Carrier
Network Addressing	Auto Assigned during commissioning
LED Indicators	
Green – Power	Indicates DC power is applied
Red – Error	Indicates an error condition
Green – Active/Standby	Indicates operating mode of each CIOC
Yellow Flashing – Pri./Sec. CN	Indicates valid control network communication

\* Actual CIOC Output to CHARMs is dependent on number of installed CHARMs.

## IS CHARMs Baseplate Hardware

Specifications for IS CHARM Baseplate	
Number of Channels per Baseplate	12
Number of Base Plates per CIOC	8
Addressing	One address plug (1 through 8)
Terminal Blocks	<ul style="list-style-type: none"> <li>■ Standard IS Terminal Block (Light Blue)</li> <li>■ IS Thermocouple / mV Terminal Block (Light Blue)</li> </ul>
Shield Connections	1 screw cage terminal per channel, plus 1 for cable shield 0.32 – 2.5 mm <sup>2</sup> / 22 – 14 AWG Gold plated connectors for shield continuity
Wire Strip Length	7 - 9 mm / 0.28 – 0.36 in.
Mounting	DIN rail Latch to T-type rail
Specifications for IS Baseplate Termination, Top and Bottom	
Shield Drain Wire Connections	2 screw cage terminals 0.32 – 2.5 mm <sup>2</sup> / 22 – 14 AWG
Wire Strip Length	7 - 9 mm / 0.28 – 0.36 in.
Specifications for Baseplate Extenders, Top and Bottom	
Primary Bus Connection	9-pin D-shell, Primary RS-485 communications bus Primary 24V DC field power Primary CHARM power
Secondary Bus Connection	9-pin D-shell, Secondary RS-485 communications bus Secondary 24V DC field power Secondary CHARM power
Specifications for Extender Cables	
Maximum Bus Length	A maximum of four extender pairs can be used and only one extender pair can exceed 0.5 meters (1.64 feet).
Available Cable Lengths	2 m, 1 m, 0.5 m (6.7 ft, 3.3 ft, 1.6 ft )
Specifications for IS Terminal Block	
Number of Connections	4 screw cage terminals 0.32 – 2.5 mm <sup>2</sup> / 22 – 14 AWG
Strip Length	7 - 9 mm / 0.28 – 0.36 in.
Maximum Current	45 mA at 28V DC max.
Color	Light blue

Specifications for IS Thermocouple / mV Terminal Block	
Number of Connections	2 screw cage terminals 0.32 – 2.5 mm <sup>2</sup> / 22 – 14 AWG
Strip Length	7 - 9 mm / 0.28 – 0.36 in.
Maximum Current	45 mA at 28V DC max.*
Color	Light blue
Specifications for Address Plug Terminal Block	
Number of Connections	None
Color	Black

\*Actual Current draw is determined by type of CHARM and associated field devices.

## IS Analog Input CHARM

Specifications for IS AI 4-20 mA HART CHARM	
Sensor Types	4-20 mA with or without HART Supports 2-wire and 4-wire device types
Nominal Signal Range (Span)	4-20 mA, (0-20 mA optional)
Full Signal Range	0 to 22 mA
Input Impedance	360 Ω
Field Power (2-Wire)	16.0V (min) at 20 mA
Accuracy Over Temperature Range	0.1% of span (0-60° C) 0.25% of span (over -40 -70°C)
Repeatability	0.05% of span
Resolution	16bit A/D converter
Calibration	None required
DC/50/60 Hz Common Mode Rejection	N/A
Isolation	Galvanically isolated according to EN 60079-11 Voltage peak value 375V DC
CHARM Power Req.	60 mA max @ 24V DC ±10%
CHARM Heat Dissipation	0.86 W
HART Support	HART v7 pass-through for AMS HART v7 variable and device status available to control
HART Data Update Rates	Typically less than one second but dependent on HART communication loading and the capability of the HART device

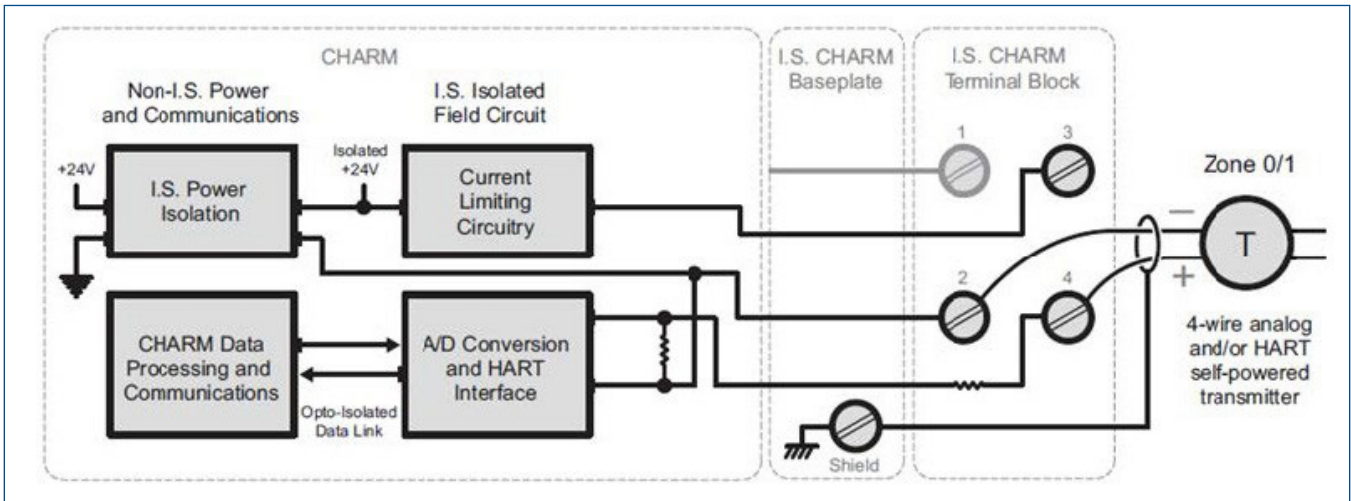
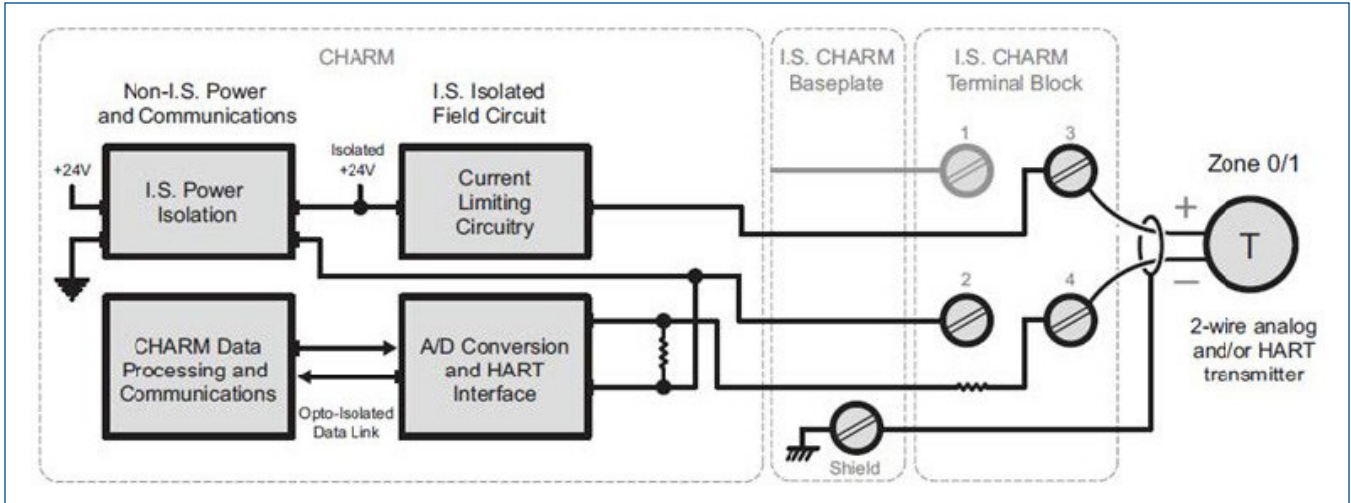

Simplified Circuit and Connection Diagrams for IS AI-CHARM4 to 20 mA HART Two Wire and Four Wire transmitters.

## IS RTD CHARM

Specifications for IS RTD Input CHARM	
Sensor Types	RTD input (Types listed in Table)
Sensor Configuration	2 wire, 3 wire, or 4 wire
Full Scale Signal Range	See table below
Accuracy	See table below
Repeatability	0.05% of span
Resolution	24 bit A/D converter / depends upon the sensor type
Calibration	None required
Sensor Excitation Current	0.5 mA in 2-wire and 4 wire configurations 0.25 mA in 3-wire
DC/50/60 Hz Common Mode Rejection	90dB typical
Isolation	Galvanically isolated according to EN 60079-11 Voltage peak value 375V DC
Open Sensor Detection	Yes
CHARM Power Req.	23 mA max @ 24V DC
CHARM Heat Dissipation	0.60 W

RTD, ohms Sensor Type Specifications				
Sensor Type	Operating Range	25° Reference Accuracy (4-wire)	Temperature Drift (4-wire)	Resolution
Pt100	-200 to 850°C	± 0.50°C	± 0.015°C/°C	~0.02°C
Pt200	-200 to 850°C	± 0.40°C	± 0.014°C/°C	~0.02°C
Pt500	-200 to 850°C	± 0.34°C	± 0.014°C/°C	~0.02°C
Pt1000	-200 to 260°C	± 0.14°C	± 0.006°C/°C	~0.01°C
Ni120	-80 to 260°C	± 0.18°C	± 0.003°C/°C	~0.01°C
Ni100	-80 to 260°C	± 0.12°C	± 0.003°C/°C	~0.01°C
Ni200	-80 to 260°C	± 0.11°C	± 0.003°C/°C	~0.01°C
Ni500	-80 to 260°C	± 0.08°C	± 0.003°C/°C	~0.01°C
Ni1000	-80 to 140°C	± 0.06°C	± 0.003°C/°C	~0.01°C
Cu10	-200 to 260°C	± 0.70°C	± 0.020°C/°C	~0.01°C
Resistance/User Defined*	0 to 2,000 Ω	± 0.50 Ω	± 0.020 Ω/°C	~0.031 Ω

\* The Callendar-Van Dusen linearization equation can be used with user defined Pt RTDs. Refer to Recommended I/O Practices in DeltaV Books online for usage information.



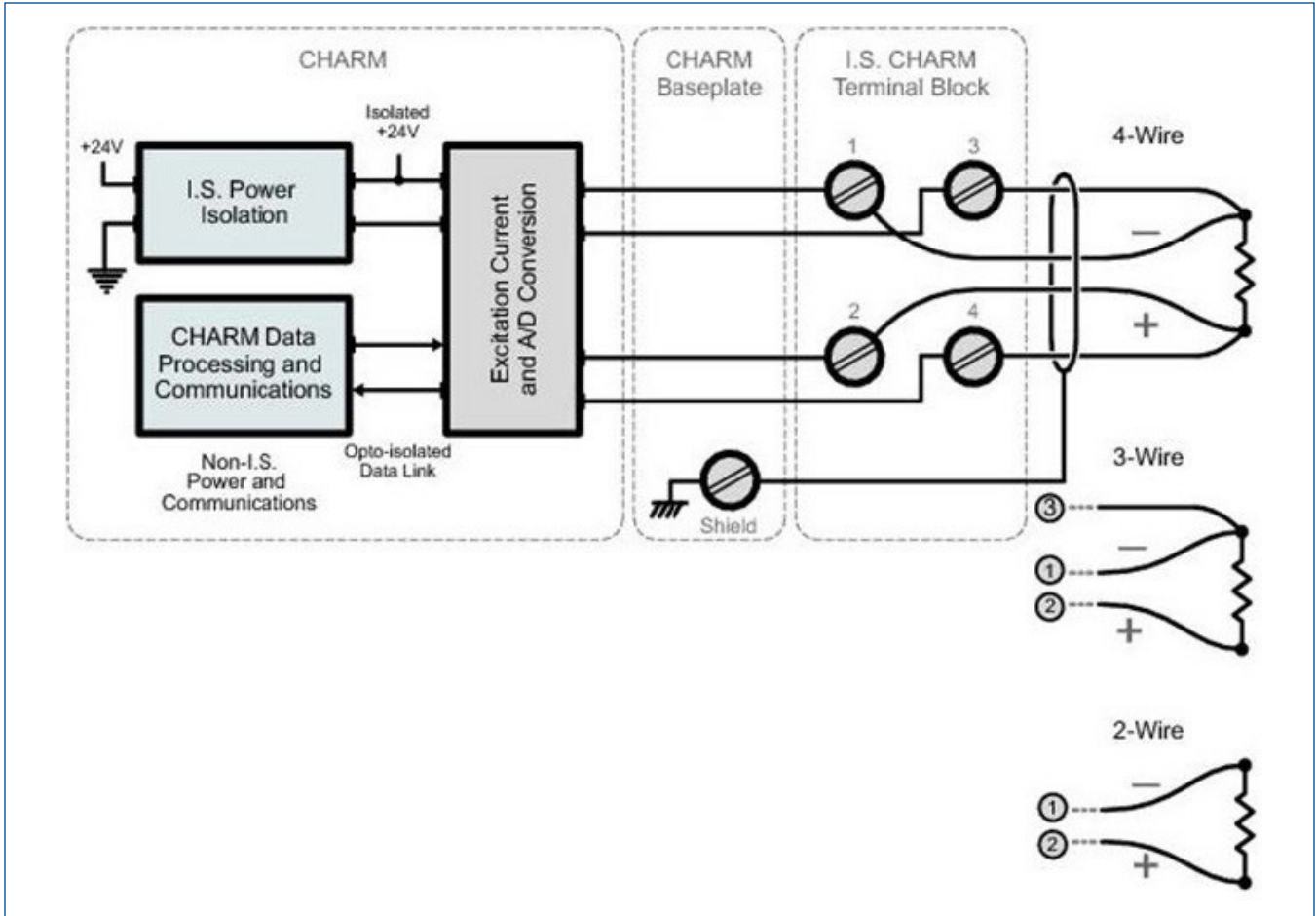

Simplified Circuit and Connection Diagrams for IS RTD CHARM.

## IS Thermocouple/mV CHARM

Specifications for IS Thermocouple/mV Input CHARM	
Sensor Types ■ Thermocouple ■ mV	B, E, J, K, N, R, S, T, uncharacterized Low level voltage source ( $\pm 20$ mV, $\pm 50$ mV, and $\pm 100$ mV)
Full Scale Signal Range	See table below
Accuracy	See table below
Repeatability	0.05% of span
Resolution	24 Bit A/D converter / depends upon the sensor type
Calibration	None required
Cold Junction Compensation(CJC) ■ Accuracy ■ Range	$\pm 0.7^{\circ}\text{C}$ -40 to $85^{\circ}\text{C}$
Temperature Drift	$0.03^{\circ}\text{C}/^{\circ}\text{C}$
Isolation	Galvanically isolated according to EN 60079-11 Voltage peak value 375V DC
Open sensor Detection	Yes
CHARM Power Req.	23 mA max @ 24V DC
CHARM Heat Dissipation	0.60 W

Sensor Type Specifications					
Sensor Type	25° Reference Accuracy <sup>1</sup>	Temperature Drift	Nominal Resolution	Full Scale	Operating Range
B	$\pm 2.50^{\circ}\text{C}$ $\pm 1.70^{\circ}\text{C}$	$\pm 0.07^{\circ}\text{C}/^{\circ}\text{C}$ $\pm 0.05^{\circ}\text{C}/^{\circ}\text{C}$	$\sim 0.024^{\circ}\text{C}$	0 to $1820^{\circ}\text{C}$	250 to $400^{\circ}\text{C}$ 400 to $1820^{\circ}\text{C}$
E	$\pm 0.60^{\circ}\text{C}$	$\pm 0.03^{\circ}\text{C}/^{\circ}\text{C}$	$\sim 0.018^{\circ}\text{C}$	-270 to $1000^{\circ}\text{C}$	-200 to $1000^{\circ}\text{C}$
J	$\pm 0.70^{\circ}\text{C}$	$\pm 0.03^{\circ}\text{C}/^{\circ}\text{C}$	$\sim 0.022^{\circ}\text{C}$	-210 to $1200^{\circ}\text{C}$	-200 to $1200^{\circ}\text{C}$
K	$\pm 1.20^{\circ}\text{C}$	$\pm 0.05^{\circ}\text{C}/^{\circ}\text{C}$	$\sim 0.025^{\circ}\text{C}$	-270 to $1372^{\circ}\text{C}$	-200 to $1370^{\circ}\text{C}$
N	$\pm 1.10^{\circ}\text{C}$	$\pm 0.04^{\circ}\text{C}/^{\circ}\text{C}$	$\sim 0.024^{\circ}\text{C}$	-270 to $1300^{\circ}\text{C}$	-200 to $1300^{\circ}\text{C}$
R	$\pm 1.70^{\circ}\text{C}$	$\pm 0.06^{\circ}\text{C}/^{\circ}\text{C}$	$\sim 0.028^{\circ}\text{C}$	-50 to $1768^{\circ}\text{C}$	-50 to $1767^{\circ}\text{C}$
S	$\pm 1.90^{\circ}\text{C}$	$\pm 0.07^{\circ}\text{C}/^{\circ}\text{C}$	$\sim 0.028^{\circ}\text{C}$	-50 to $1768^{\circ}\text{C}$	-50 to $1767^{\circ}\text{C}$
T	$\pm 0.70^{\circ}\text{C}$	$\pm 0.02^{\circ}\text{C}/^{\circ}\text{C}$	$\sim 0.01^{\circ}\text{C}$	-270 to $400^{\circ}\text{C}$	-200 to $400^{\circ}\text{C}$
$\pm 100$ mV	50 $\mu\text{V}$	$\pm 2.5 \mu\text{V}/^{\circ}\text{C}$	$\sim 0.0031$ mV	-100 to 100 mV	-100 to 100 mV
$\pm 50$ mV	40 $\mu\text{V}$	$\pm 1.7 \mu\text{V}/^{\circ}\text{C}$	$\sim 0.0015$ mV	-50 to 50 mV	-50 to 50 mV
$\pm 20$ mV	20 $\mu\text{V}$	$\pm 0.8 \mu\text{V}/^{\circ}\text{C}$	$\sim 0.0006$ mV	-20 to 20 mV	-20 to 20 mV

<sup>1</sup>Total error is made up of the 25 °C reference accuracy value, plus the CJC accuracy value, plus the sensor accuracy value.

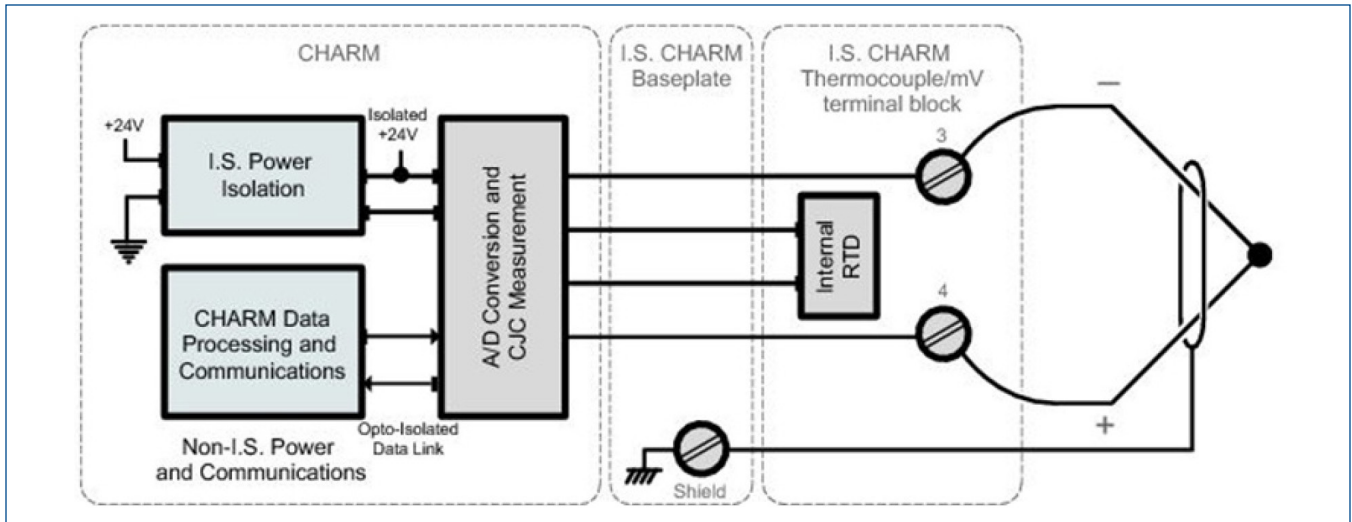

Simplified Circuit and Connection Diagram for IS Thermocouple/mV CHARM with IS Thermocouple/mV Terminal Block.

## IS Analog Output CHARM

Specifications for IS AO 4-20 mA HART CHARM	
Sensor Types	4 to 20 mA with or without HART
Nominal Signal Range (Span)	4-20 mA, (0-20 mA optional)
Full Signal Range	0 to 22 mA
Load Resistance	750 Ohm max.
Voltage to Load	15V (min) @ 20 mA
Accuracy Over Temperature Range	0.25% of span (0 to 60°C) 0.5% of span (-40 to 70°C)
Resolution	16 bit A/D converter
Calibration	None required
Isolation	Galvanically isolated according to EN 60079-11 Voltage peak value 375V DC
CHARM Power Req.	56 mA max @ 24V DC ±10%
CHARM Heat Dissipation	1.1 W
HART Support	HART v7 pass-through for AMS HART v7 variable and device status available to control
HART Data Update Rates	Typically less than one second but dependent on HART communication loading and the capability of the HART device

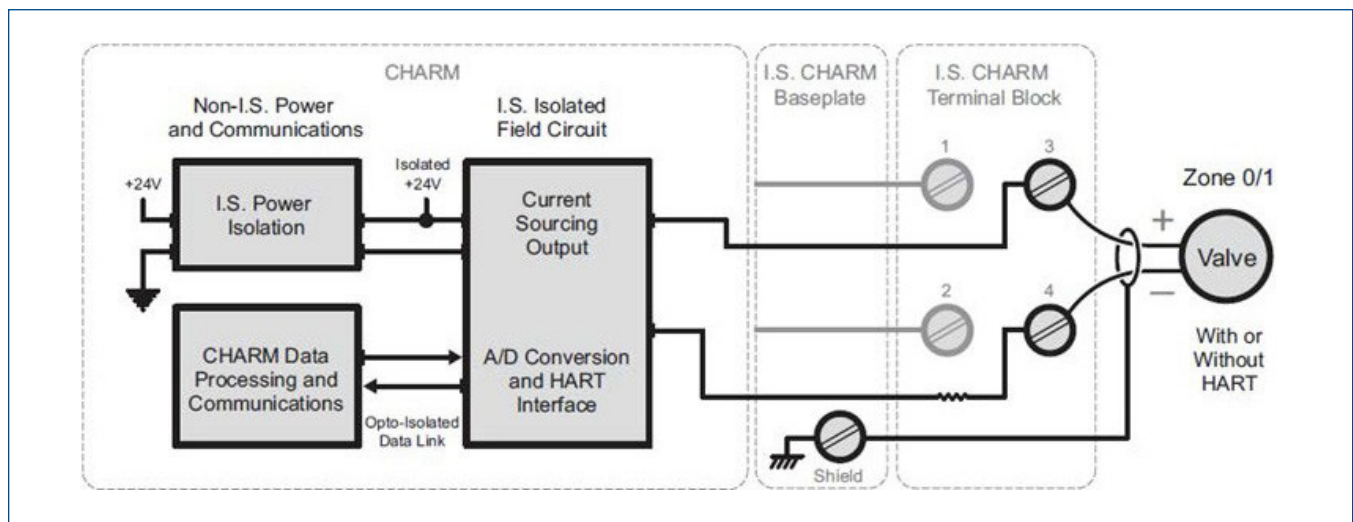

Simplified Circuit and Connection Diagram for IS AO HART CHARM.

## IS Discrete Input CHARM

Specifications for IS DI NAMUR CHARM	
Sensor Types	NAMUR sensors, dry contacts
Detection Level for On	>2.1 mA
Detection Level for Off	<1.2 mA
Channel Impedance	1kOhm ± 10%
Wetting Voltage	8V DC ± 1V DC
Fault detection capable with NAMUR sensor or with an optional field resistor pack* as shown on Option 2 in diagram below (Option 1 in diagram below is not fault detection capable)	<ul style="list-style-type: none"> <li>■ Guaranteed short circuit: &lt;100 Ω</li> <li>■ Guaranteed good status: 360 Ω to 20 kΩ</li> <li>■ Guaranteed open circuit: &gt; 75 kΩ</li> </ul>
Configurable Channel Types: <ul style="list-style-type: none"> <li>■ Discrete Input</li> <li>■ Pulse Count</li> </ul>	Dry contact or discrete state sensor changing <2 Hz Pulse train 0.1 Hz to 10 KHz, 50 μsec min pulse width
Isolation	Galvanically isolated according to EN 60079-11 Voltage peak value 375V DC
CHARM Power Req.	28 mA max @ 24V DC ± 10%
CHARM Heat Dissipation	0.57 W

\*VS6904 End of Line Resistance Module can be used for option 2, see *DeltaV SIS Conditioning Components PDS* for more info.

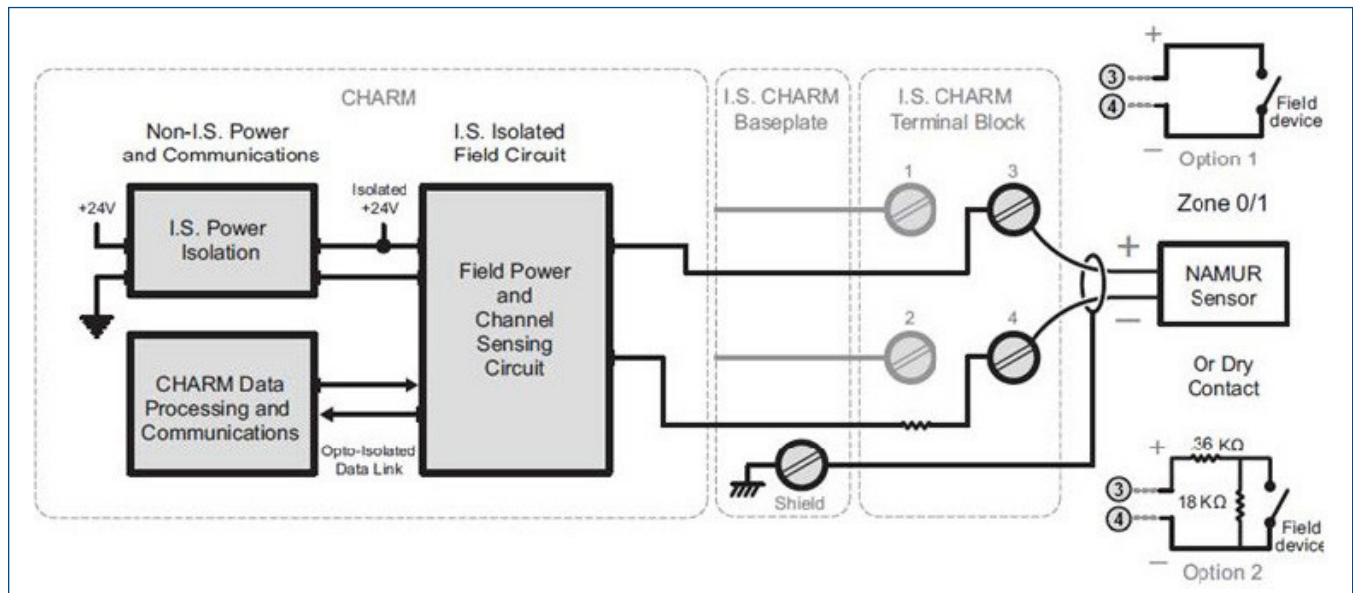

Simplified Circuit and Connection Diagram for IS DI NAMUR CHARM.

## IS Discrete Output CHARM

Specifications for IS DO 45 mA CHARM	
Device Type	Solenoid Coils
On State Output Rating	22V to 25V (open circuit); 11V at 45 mA
Off State Leakage Current	230µA
Line Fault Detection	<ul style="list-style-type: none"> <li>■ Guaranteed short circuit: &lt;100 Ω load</li> <li>■ Guaranteed good status: 150 Ω to 20 kΩ load</li> <li>■ Guaranteed open circuit: &gt;25 kΩ load</li> </ul>
Configurable Output Behavior	<ul style="list-style-type: none"> <li>■ Momentary output</li> <li>■ Continuous pulse output</li> <li>■ Line fault testing</li> </ul>
Line Fault Test Timing	180 to 220 µsec
Isolation	Galvanically isolated according to EN 60079-11 Voltage peak value 375V DC
CHARM Power Req.	78 mA max @ 24V DC ±10%
CHARM Heat Dissipation	1.4 W

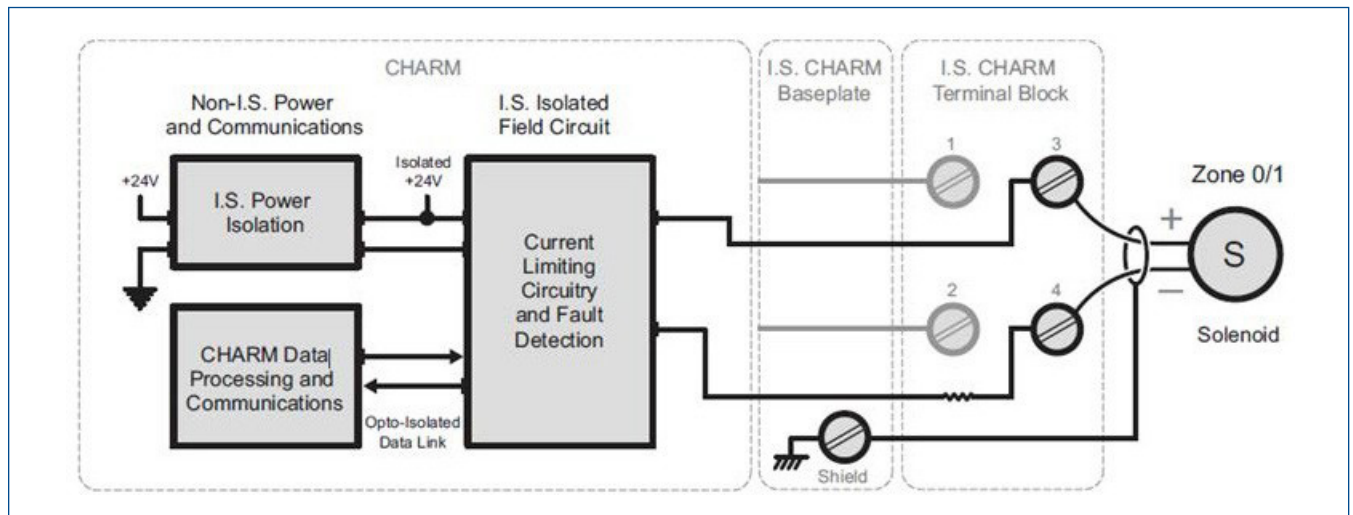

Simplified Circuit and Connection Diagram for IS DO 45 mA CHARM.

## ASCO Numatics 580 CHARM Node

Specifications for ASCO Numatics 580 CHARM Node	
Bus Power	6.3V DC at 100mA
Valve Power	24V DC at 1.07A
Power and Bus Connector	A-Coded 5 Pin M12 Male
LEDs	Module Status and Network Status
Operating Temperature Range	-10 to 115°F (-23 to 46°C)
Operating Humidity	95% Relative Humidity, Non-condensing
Vibration Shock	EC 60068-2-27, IEC 60068-2-6
Moisture	IP65 Certified
Maximum Valve Solenoid Outputs	48
Diagnostics	Power, short, open load conditions are monitored
More Information	<a href="http://www.asco.com/580charm">http://www.asco.com/580charm</a> *

\*For hazardous area installations, please refer to installation instructions from ASCO.



580 CHARM Node.



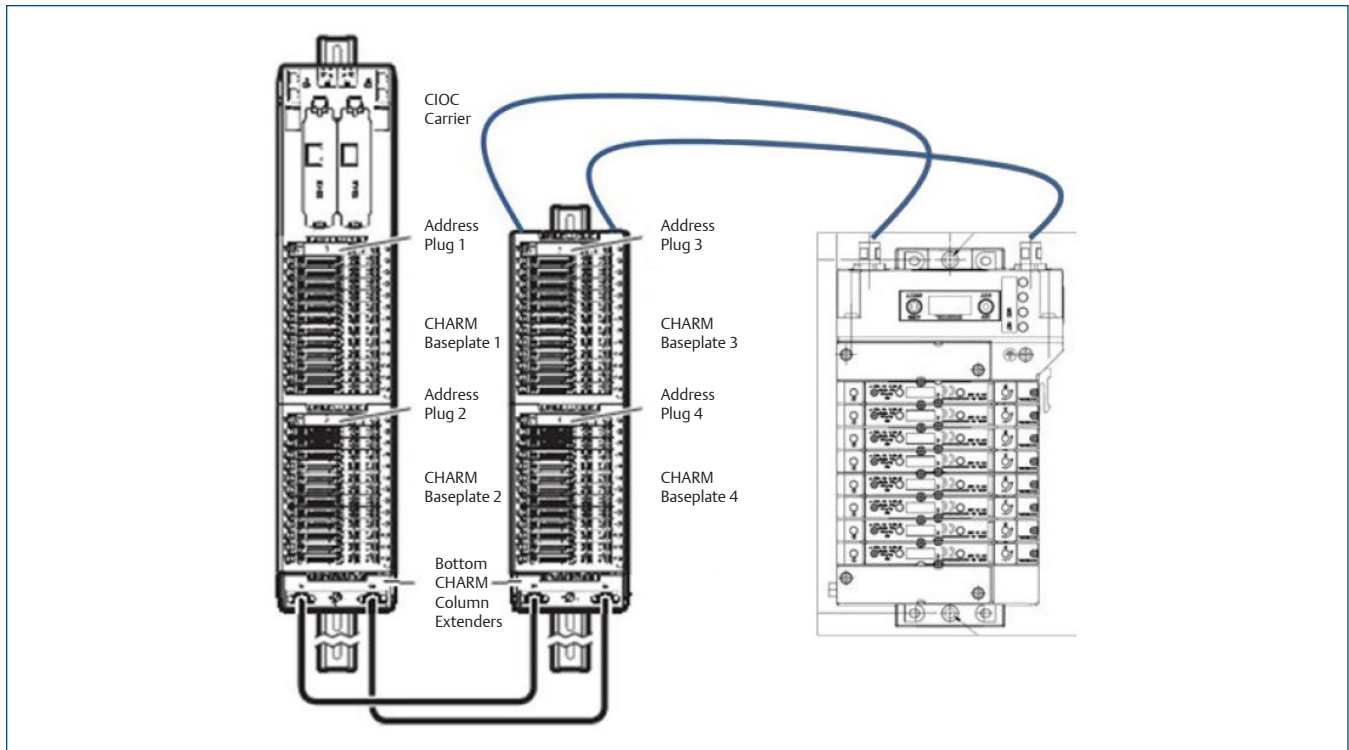

Connection to DeltaV IS Electronic Marshalling.

## System Compatibility

DeltaV IS CHARM I/O hardware requires:

- SD Plus controllers with DeltaV v11.3.1 or later software
- SX controllers with DeltaV v11.3.1 or later software
- SQ controllers with v11.3.1 or later software
- MD Plus controllers with DeltaV v14.3 or later software
- MQ controllers with DeltaV v14.3 or later software
- MX controllers with DeltaV v14.3 or later software
- PK controllers with DeltaV v14.3 or later software

When assigning CHARMS to MD Plus and SD Plus controllers, make sure to evaluate the Time Utilization Chart on the controller in DeltaV Diagnostics to ensure the additional communication load can be handled by the controller.

S-series and M-series controllers can be installed on the same DeltaV Area Control Network in v11.3 and beyond. PK controllers can be installed on the same DeltaV Area Control network in v14.3 and beyond.

Control modules can be assigned to any controller and inter-controller references are fully supported between different types of controllers.

- **CHARM I/O Card:** IS CHARMS installed on IS CHARM baseplates can be connected to a CHARM I/O Card carrier, using a baseplate separator and a special fuse in each of the two power supply lines of the CHARM I/O carrier.
- **Non-IS CHARM Baseplates:** Non-IS CHARM baseplates can be extended with CHARM baseplates, using a baseplate separator.
- **IS CHARM Baseplates:** IS CHARM baseplates cannot be extended with non-IS CHARM Baseplates but can be extended with the ASCO Numatics 580 CHARM Node.
- **Baseplate Extender:** IS CHARM baseplates can be connected to CHARM baseplate extenders using baseplate separators
- **Baseplate Terminator:** IS CHARM baseplates can be connected to CHARM baseplate terminators using baseplate separators.

Refer to installation instructions for rules governing IS wiring.

## Certifications

The following certifications are available for DeltaV IS Electronic Marshalling (see actual certificates for exact certifications for each product):

### ■ CE

EMC - EN 61326-1

### ■ FM

FM 3600

FM 3610

FM 3611

ANSI/ISA 60079-0

ANSI/ISA 60079-11

ANSI/ISA 60079-15

### ■ CSA

CSA C22.2 No. 213

CSA-C22.2 No. 61010-1

CSA-C22.2 No. 60079-0

CSA-C22.2 No. 60079-11

CSA-C22.2 No. 60079-15

### ■ ATEX

EN60079-0

EN60079-11

EN60079-15

EN60079-26

### ■ IEC-Ex

IEC60079-0

IEC60079-11

IEC60079-15

IEC60079-26

### ■ Marine Certifications: IACS E10

DNV-GL Marine Certificate

### ■ Achilles Communications Certification

CIOC: Level 1 (v13.3.1, v14.FP1)

CIOC2: Level 2 (v14.3, v14.FP1)

## Hazardous Area/Location

DeltaV IS Electronic Marshalling can be installed and used based on the following Standards (see actual certificates for exact product markings for each product):

### ■ FM (USA)

Installation:

Class I, Division 2, Groups A, B, C, D, T4

Class I, Zone 2 AEx nAc IIC

Field Circuits:

Class I, Division 1, Groups A, B, C, D

Class II, Division 1, Groups E, F, G

Class III

Class I, Zone 0 [AEx ia] IIC

### ■ cFM (Canada)

Installation:

Class I, Division 2, Groups A, B, C, D, T4

Class I, Zone 2 Ex nA IIC

Field Circuits:

Class I, Division 1, Groups A, B, C, D

Class II, Division 1, Groups E, F, G

Class III

Class I, Zone 0 [Ex ia] IIC

Regarding the Installation instructions please refer to the following Documents:

ATEX/IECEx Installation Instructions IS-CHARM Subsystem	12P6523
Control Drawing DeltaV IS-CHARMs Subsystem	12P6122
Control Drawing DeltaV IS-CHARMs	12P6123

- **ATEX**

Installation:

II 3 (1) G Ex nA [ia Ga] IIC Gc

Field Circuits:

II (1) G [Ex ia Ga] IIC

II (1) D [Ex ia Da] IIIC

- **IEC-Ex**

Installation:

Ex nA [ia Ga] IIC Gc

Field Circuits:

[Ex ia Ga] IIC

[Ex ia Da] IIIC

## Ordering Information

CHARM I/O CARD	
Description	Model Number
<b>Redundant CIOC2 with Copper Ethernet</b> , includes redundant pair of CHARM I/O Card 2, CHARM I/O Carrier with Screw Terminals, Copper I/O Ports, a Baseplate Identifier and a Baseplate Separation Wall	SE6505T01
<b>Redundant CIOC2 with fiber optics Ethernet</b> , includes redundant pair of CHARM I/O Card 2, CHARM I/O Carrier with Screw Terminals, Fiber optic I/O Ports, a Baseplate Identifier and a Baseplate Separation Wall	SE6505T02
<b>Redundant CIOC Carrier Assembly with Copper Ethernet</b> , includes CHARM I/O Carrier with Screw Terminals, Copper I/O Ports, a Baseplate Identifier and a Baseplate Separation Wall	SE6501T05
<b>Redundant CIOC Carrier Assembly with fiber optics Ethernet</b> , includes CHARM I/O Carrier with Screw Terminals, Fiber-Optic I/O Ports, a Baseplate Identifier and a Baseplate Separation Wall	SE6501T06
<b>Redundant CIOC2</b> , includes 2 CHARMs I/O Card 2, (Order these with standard cabinets)	SE6504
IS CHARM Baseplates	
Description	Model Number
<b>IS CHARMS Baseplate Assembly with Standard IS CHARM Terminal Blocks</b> , includes IS CHARMS Baseplate, IS CHARM Address Terminal Block, 12 IS CHARM Standard Terminal blocks and a Baseplate Separation Wall	SE4608T01
CHARM I/O Baseplate Address Plugs	
Description	Model Number
<b>Addressing Plugs</b> , includes Address Plugs 1 through 8	SE4602
<b>Addressing Plugs</b> , includes Address Plugs 1 through 4	SE4613

CHARM I/O Baseplate Extender, Terminator & Cables	
Description	Model Number
<b>CHARMs Baseplate Extender with Cable Connectors, Top (Male)</b> includes a Baseplate Identifier and a Baseplate Separation Wall	SE4603T05
<b>CHARMs Baseplate Extender with Cable Connectors, Bottom (Female)</b> includes a Baseplate Identifier and a Baseplate Separation Wall	SE4603T06
<b>CHARMs Baseplate Terminator, Top (Male)</b> includes a Baseplate Identifier and a Baseplate Separation Wall	SE4604T03
<b>CHARMs Baseplate Terminator, Bottom (Female)</b> includes a Baseplate Identifier and a Baseplate Separation Wall	SE4604T04
<b>CHARMs Baseplate Cables</b> , includes two 0.5m cables	SE4605T02
<b>CHARMs Baseplate Cables</b> , includes two 1m cables	SE4605T03
<b>CHARMs Baseplate Cables</b> , includes two 2m cables	SE4605T04

Each vertical DIN rail requires a DIN Rail stop to lock baseplates in position. Order VE4054DRS, which is a box of 5.

## Ordering Information

IS CHARMs	
Description	Model Number
IS DI NAMUR	SE4305T01
IS DO 45 mA	SE4306T01
IS AI 4-20 mA HART	SE4307T01
IS AO 4-20 mA HART	SE4308T01
IS Thermocouple/mV	SE4309T01
IS RTD	SE4310T01

IS CHARMs and IS Terminal Block Assembly's	
Description	Model Number
IS Thermocouple/mV CHARM with IS Thermocouple/mV Terminal Block	SE4309T51

## Additional Ordering Information for IS CHARM Protection Cover

IS CHARM Protection Cover	
Description	Model Number
IS CHARM Protection Cover; Package of 12	SE6104

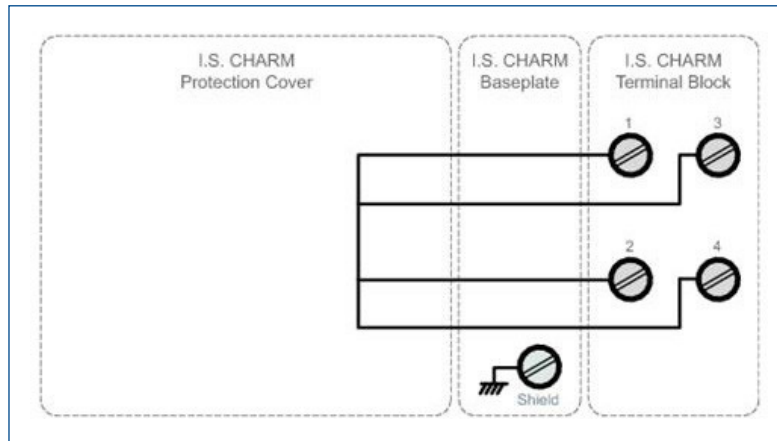

*Simplified Circuit and Connection Diagram for IS CHARM Protection Cover.*

When the I.S. CHARM Protection Cover is installed, all terminals on the I.S. CHARM Terminal Block are shortened! The shortened Terminals can be connected to Chassis Ground, while allowing the ground to be Daisy chained to the next I.S. CHARM Terminal block, where the next I.S. CHARM Protection Cover got installed.

### Prerequisites

DeltaV IS Electronic Marshalling hardware requires DeltaV v11.3.1 or later software. Assigning CHARMS to MD Plus, MQ, MX, and PK controllers is supported in DeltaV v14.3 and later, but is not supported on M-series Controller Interfaces to PROVVOX and RS3.

CHARM I/O Card 2 (CIOC2) requires DeltaV v14.3 or later software.

Electronic Marshalling requires use of DeltaV Smart Switches between controllers and CIOCs, please refer to Network Considerations for M-series with Electronic Marshalling White Paper when adding Electronic Marshalling to M-series systems.

IS CHARM FUSE	
Description	Model Number
Fuse Holder and Fuse Assembly for 24V DC Power Supply of CHARM I/O CARD	SE4610T01 *

*\*Two of these Fuse Assemblies have to be ordered with any SE6505T01 or SE6505T02, when used with IS CHARM baseplates.*

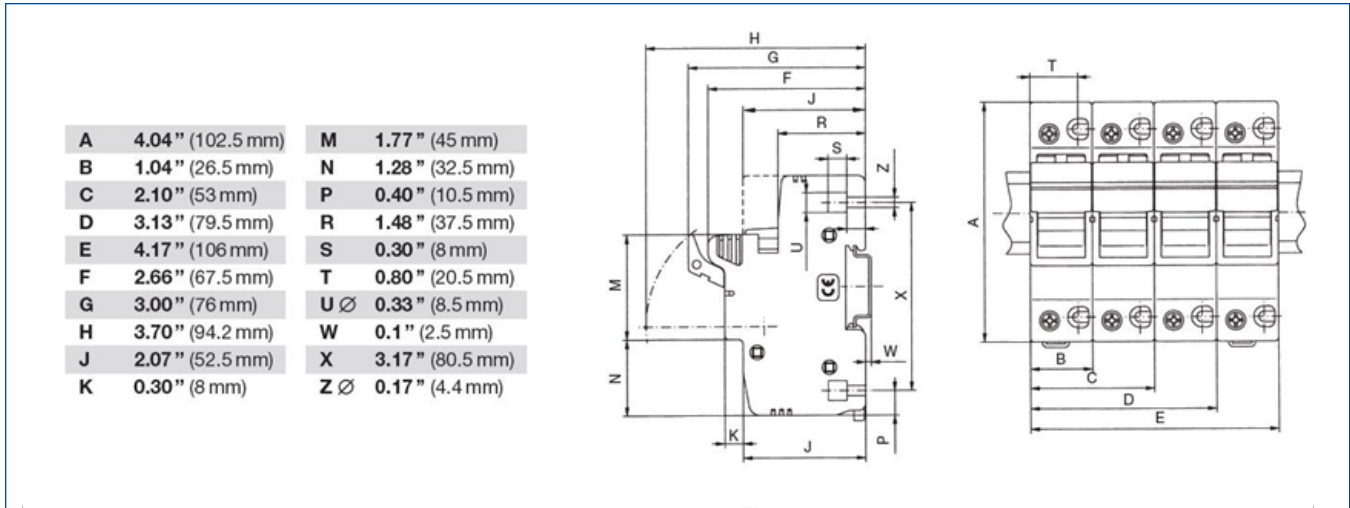

Outside Dimensions of the Fuse Holder.

### CHARM I/O Spare Part Ordering Information

CHARM I/O Spare Parts	
Description	Model Number
Power Terminal Plug for CHARM I/O Carrier	KJ4005X1-BF1
I/O Port Switch Module; Copper; for CIOC Carriers	KL1601X1-BA1
I/O Port Switch Module; Fiber; for CIOC Carriers	KL1602X1-BA1*

\* Fiber Optic Ethernet I/O Ports are not cascade able.

### IS CHARM I/O Labeling Ordering Information

IS CHARM I/O Labeling Parts	
Description	Model Number
Channel Identifier Labels for Intrinsically-Safe CHARM Baseplates; Package of 8	SE4609T01
IS Charm Baseplate Separation Wall; Package of 9	SE4609T02
Replacement Fuse for SE4610T01 Fuseholder Assembly	KL4510X1-FA1
Replacement Fuseholder for SE4610T01 Fuseholder Assembly	KL4510X1-GA1

©2021, Emerson. All rights reserved.

The Emerson logo is a trademark and service mark of Emerson Electric Co. The DeltaV logo is a mark of one of the Emerson family of companies. All other marks are the property of their respective owners.

The contents of this publication are presented for informational purposes only, and while diligent efforts were made to ensure their accuracy, they are not to be construed as warranties or guarantees, express or implied, regarding the products or services described herein or their use or applicability. All sales are governed by our terms and conditions, which are available on request. We reserve the right to modify or improve the designs or specifications of our products at any time without notice.

**Contact Us**

 [www.emerson.com/contactus](http://www.emerson.com/contactus)