

DEPARTMENT OF THE ARMY TECHNICAL MANUAL

DIRECT SUPPORT, GENERAL SUPPORT,
AND DEPOT MAINTENANCE MANUAL
INCLUDING REPAIR PARTS AND
SPECIAL TOOL LISTS

PISTOL, CALIBER .45, AUTOMATIC: M1911A1,
WITH HOLSTER, W/E
(1005-673-7965)

PISTOL, CALIBER .45, AUTOMATIC: M1911A1,
WITH HOLSTER, SHOULDER, W/E
(1005-561-2003)

This copy is a reprint which includes current pages from Changes 1 through 4.

HEADQUARTERS, DEPARTMENT OF THE ARMY

APRIL 1968

SAFETY PRECAUTIONS

WARNING,	REFERENCE
<p>Before starting an inspection, be sure to clear the weapon. DO NOT actuate the trigger until the weapon has been cleared. Inspect the chamber, to insure that it is empty, and check to see that no ammunition is in position to be introduced (magazine). Avoid having live ammunition in the vicinity of work area.</p>	<p>Par 2-6</p>

CHANGE)
)
No. 4)

HEADQUARTERS
DEPARTMENT OF THE ARMY
WASHINGTON, DC, 25 February 1976

Direct Support, General Support and Depot Maintenance Manual
Including Repair Parts and Special
Tool Lists:

**PISTOL, CAL .45, AUTOMATIC: M1911A1, WITH HOLSTER; W/E
(1005-00-673-7965)**

**PISTOL, CAL .45, AUTOMATIC: M1911A1, WITH HOLSTER,
SHOULDER, W/E (1005-00-561-2003)**

Current as of 28 November 1975.

TM 9-1005-211-35, 4 April 1968, is Changed as follows:

Title is changed as shown above.

Appendix B is superseded as follows:

APPENDIX B

DIRECT SUPPORT AND GENERAL SUPPORT MAINTENANCE REPAIR PARTS AND SPECIAL TOOLS LIST (INCLUDING DEPOT MAINTENANCE REPAIR PARTS AND SPECIAL TOOLS)

SECTION I. INTRODUCTION

B-1. Scope

This appendix lists repair parts; special tools; test, measurement, and diagnostic equipment (TMDE); and other support equipment required for the performance of direct support and general support maintenance of the .45 cal automatic pistol.

B-2. General

This repair parts and special tools list is divided into the following sections:

a. Section II. Repair Parts List. A list of repair parts authorized for use in the performance of maintenance. The list also includes parts which must be removed for replacement of the authorized parts. Parts lists are composed of functional groups in ascending numerical sequence, with the parts in each group listed in figure and item number sequence. Bulk materials are listed in NSN sequence.

b. Section III. Special Tools List. A list of special tools, TMDE, and support equipment authorized for the performance of maintenance.

c. Section IV. National Stock Number (NSN) and Part Number Index. A list, in ascending numerical sequence of the National item Identification Number (NIIN), of all National stock numbers appearing in the listings, followed by a list, in alphanumeric sequence, of all part numbers appearing in the listings. National stock numbers and part numbers are cross-referenced to each illustration figure and item number appearance.

B-3. Explanation of Columns

The following provides an explanation of columns found in the tabular listings:

a. Illustration. This column 18 divided as follows:

(1) Figure number. Indicates the figure number of the illustration in which the item is shown.

(2) Item number. The number used to identify each item called out in the illustration.

b. Source, Maintenance, and Recoverability Codes (SMR).

(1) *Source code.* Source codes are assigned to support items to indicate the manner of acquiring

support items for maintenance, repair, or overhaul of end items. Source codes are entered in the first and second positions of the Uniform SMR Code format as follows:

Code	Definition
PA.....	Item procured and stocked for anticipated or known usage.
PB.....	Item procured and stocked for insurance purposes because essentiality dictates that a minimum quantity be available in the supply system.
PC.....	Item procured and stocked and which otherwise would be coded PA except that it is deteriorative in nature.
PD.....	Support item, excluding support equipment, procured for initial issue or outfitting and stocked only for subsequent or additional initial issues or outfittings. Not subject to automatic replenishment.
PE.....	Support equipment procured and stocked for initial issue or outfitting to specified maintenance repair activities.
PF.....	Support equipment which will not be stocked but which will be centrally procured on demand.
PG.....	Item procured and stocked to provide for sustained support for the life of the equipment. It is applied to an item peculiar to the equipment which,

Code	Definition
	because of probable discontinuance or shutdown of production facilities, would prove uneconomical to reproduce at a later time.
KD.....	An item of a depot over-haul/repair kit and not purchased separately. Depot kit defined as a kit that provides items required at the time of overhaul or repair.
KF.....	An item of a maintenance kit and not purchased separately. Maintenance kit defined as a kit that provides an item that can be replaced at organizational or intermediate levels of maintenance.
KB.....	Item included in both a depot overhaul/repair kit and a maintenance kit.
MO.....	Item to be manufactured or fabricated at organizational level.
MF.....	Item to be manufactured or fabricated at the direct support maintenance level.
MH.....	Item to be manufactured or fabricated at the general support maintenance level.
MD.....	Item to be manufactured or fabricated at the depot maintenance level.
AO.....	Item to be assembled at organizational level.
AF.....	Item to be assembled at direct support maintenance level.

Code	Definition
AH	Item to be assembled at general support maintenance level.
AD	Item to be assembled at depot maintenance level.
XA	Item is not procured or stocked because the requirements for the Item will result in the replacement or the next higher assembly.
XB	Item is not procured or stocked. If not available through salvage, requisition.
XD	A support item that is not stocked. When required, item will be procured through normal supply channels.

NOTE

Cannibalization or salvage may be used as a source of supply for any item source coded above, except those coded XA, XD, and aircraft support items as restricted by AR 700-42.

(2) *Maintenance code.* Maintenance codes are assigned to indicate the levels of maintenance authorized to USE and REPAIR support items. The maintenance codes are entered in the third and fourth positions of the Uniform SMR Code format as follows:

(a) The maintenance code entered in the third position will indicate the lowest maintenance

level authorized to remove, replace, and use the support item. The maintenance code entered in the third position will indicate one of the following levels of maintenance:

Code	Application/ explanation
C	Crew or operator maintenance performed within organizational maintenance.
O	Support item is removed, replaced, used at the organizational level.
I	Support item is removed, replaced, used by the direct support element of integrated direct support maintenance.
P	Support item is removed, replaced, used at the direct support level.
H	Support item is removed, replaced, used at the general support level.
D	Support items that are removed, replaced used at depot, mobile depot, specialized repair activity only.

NOTE

Codes "I" and "F" will be considered the same by direct support units.

(b) The maintenance code entered in the fourth position indicates whether the item is to be

repaired and identifies the lowest maintenance level with the capability to perform complete repair (i.e., all authorized maintenance functions). This position will contain one of the following maintenance codes:

Code	Application/ explanation
O	The lowest maintenance level capable of complete repair of the support item is the organizational level.
P	The lowest maintenance level capable of complete repair of the support item is the direct support level.
H	The lowest maintenance level capable of complete repair of the support item is the general support level.
D	The lowest maintenance level capable of complete repair of the support item is the depot level, performed by depot, mobile depot, or specialized repair activity.
L	Repair restricted to designated specialized repair activity.
Z	Nonreparable. No repair is authorized.
B	No repair is authorized. The item may be reconditioned by adjusting, lubrication, etc., at the user level. No parts or special tools are procured for the maintenance of this item.

(3) *Recoverability code.* Recoverability codes are assigned to support items to indicate the disposition action on unserviceable items. The recoverability code is, entered in the fifth position of the Uniform SMR Code format as follows:

Recoverability Code	Definition
Z	Nonreparable item. When unserviceable, condemn and dispose at the level indicated in position 3.
O	Reparable item. When uneconomically repairable, condemn and dispose at organizational level.
P	Reparable Item. When uneconomically repairable, condemn and dispose at the direct support level.
H	Reparable item. When uneconomically repairable, condemn and dispose at the general support level.
D	Reparable item. When beyond lower level repair capability, return to depot. Condemnation and disposal not authorized below depot level.
L	Reparable item. Repair, condemnation, and disposal not authorized below depot/specialized repair activity level.
A	Item requires special handling or condemnation procedures because of specific reasons (i.e., precious metal content, high dollar value, critical material, or hazardous material). Refer to appropriate manuals/directives for specific instructions.

c. *National Stock Number (NSN)*. Indicates the National stock number assigned to the item and will be used for requisitioning purposes.

d. *Part Number*. Indicates the primary number used by the manufacturer (individual, company, firm, corporation, or Government activity), which controls the design and characteristics of the item by means of its engineering drawings, specifications, standards, and inspection requirements, to identify an item or range of items.

NOTE

When a stock numbered item is requisitioned, the repair received may have a different part number than the part being replaced.

e. *Federal Supply Code for Manufacturer (FSCM)*. The FSCM is a five-digit numeric code listed in SB 708-42 which is used to identify the manufacturer, distributor, or Government agency, etc.

f. *Description*. Indicates the Federal item name and, if required, a minimum description to identify the item. Items that are included in kits and sets are listed below the name of the kit or set with the quantity of each item in the kit or set indicated in the quantity incorporated in unit column. When the part to be used differs between serial numbers of the same model, the effective serial numbers are shown as the last line of the description. In the special tools list, the initial basis of issue (BOI) appears as the last line in the entry for each special tool TMDE, and support equipment. When the

density of the equipments supported exceeds density spread indicated in the basis of Issue, the total authorization is increased accordingly.

g. *Unit of Measure (U/M)*. Indicates the standard or the basic quantity of the listed item as used in performing the actual maintenance function. This measure is expressed by a two-character alphabetical abbreviation (e.g., ea, in., pr, etc.). When the unit of measure differs from the unit of issue, the lowest unit of issue that will satisfy the required units of measure will be requisitioned.

h. *Quantity Incorporated in Unit*. Indicates the quantity of the item used in the breakout shown on the illustration figure, which is prepared for a functional group, subfunctional group, or an assembly. A "V" appearing in this column in lieu of a quantity indicates that no specific quantity is applicable (e.g., shims, spacers, etc.).

B-4. Special Information

a. Detailed manufacturing instructions for items source coded to be manufactured or fabricated are found in chapters 2 and 3. Bulk materials required to manufacture items are listed in the Bulk Material Group in section II of this appendix.

b. Detailed assembly instructions for Items source coded to be assembled are found in chapters 2 and 3.

c. Repair parts kits and gasket sets appear as the last entries in the repair parts listing for the figure in which its parts are listed as repair parts.

d. Action change codes indicated in the left-hand margin of the listing page denote the following:

- N**..... Indicates an added item
- C**..... Indicates a change in data
- R**..... Indicates a change in NSN only

e. Usable on codes are shown in the description column. Uncoded items are applicable to all models. Identification of the usable on codes used in this publication are:

Code	Used on
612	Pistol, cal .45 automatic: M1911A1, w shoulder holster, w/e
163	Pistol, cal .45 automatic: M1911A1 w holster, w/e

B-5. How to Locate Repair Parts

a. When National Stock Number or Part Number is Unknown:

(1) *First.* Using the table of contents determine the functional group within which the repair part belongs. This is necessary since illustrations are prepared for functional groups and listings are divided into the same groups.

(2) *Second.* Find the illustration covering the functional group to which the repair part belongs.

(3) *Third.* Identify the repair part on the illustration and note the illustration figure and item number of the repair part.

(4) *Fourth.* Using the repair parts listing, find the figure and item number noted on the illustration.

b. When National Stock Number or Part Number is Known:

(1) *First.* Using the Index of National stock numbers and part numbers, find the pertinent National stock number or part number. This index is in ascending NIIN (the last nine figures of the NSN) sequence followed by a list of part numbers in ascending alphanumeric sequence, cross-referenced to the illustration figure number and item number.

(2) *Second.* After finding the figure and item number, locate the figure and item number in the repair parts list.

B-6. Abbreviations

Abbreviation	Explanation
assy.....	assembly
cal	caliber
ed-pltd.....	cadmium plated
cham.....	chamfered
dia	diameter
fl-ck-hd.....	flat countersunk, head
h	height
lg	long/length
LH	left-hand
LOA.....	length overall
max	maximum
oa.....	overall
phos-ctd.....	phosphate coated
RH.....	right-hand
tk	stock
st/S.....	steel
thk.....	thick

SECTION II. REPAIR PARTS LIST

(1) ILLUSTRATION		(2)	(3)	(4)	(5)	(6)	(7)	(8)
(a) FIG NO.	(b) ITEM NO.	SMR CODE	FEDERAL STOCK NUMBER	PART NUMBER	FSCM	DESCRIPTION USABLE ON CODE	U/M	QTY INC IN UNIT
N	8-1	NA		7269655	19204	GROUP 00 REPAIR PARTS FOR: PISTOL, CAL. 45, AUTOMATIC, MAJOR GROUPS AND ASSEMBLIES PISTOL, CALIBER .45 AUTOMATIC GROUP 01 PISTOL, CAL. .45 AUTOMATIC, MAJOR GROUPS AND ASSEMBLIES	EA	1
N	B-1	1 PACZZ	1005-00-550-8694	5508694	19204	MAGAZINE, CARTRIDGE	EA	3
N	B-1	2 PAPZZ	1005-00-600-8597	6008595	19204	STOP, SLIDE	EA	1

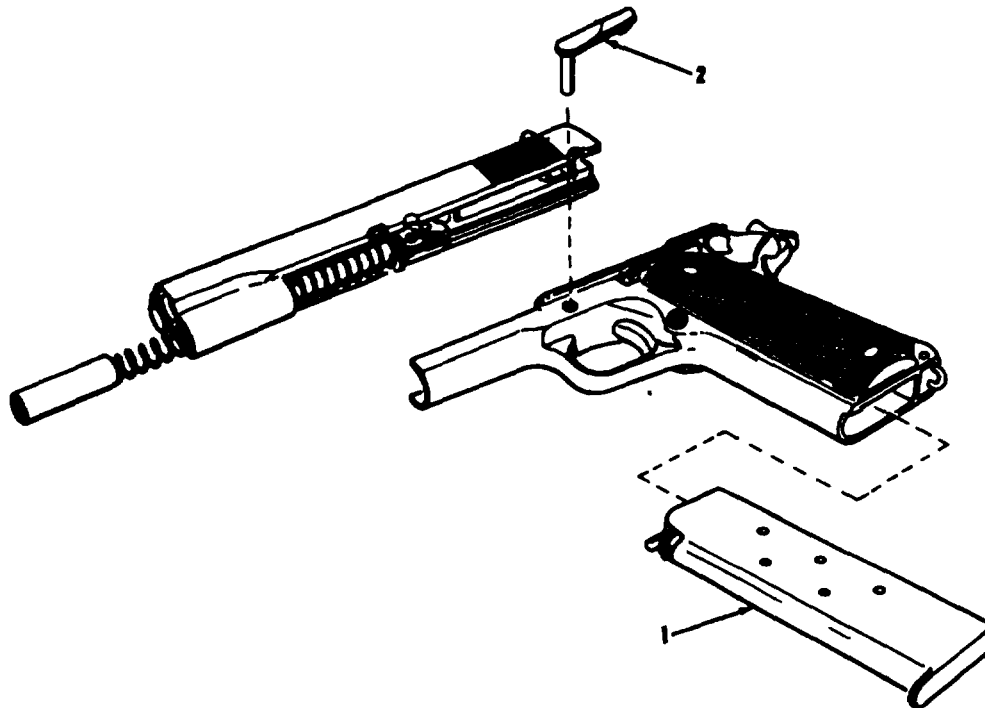

WE 17399

Figure B-1. Major groups and assemblies-partially exploded view.

(1) ILLUSTRATION		(2)	(3)	(4)	(5)	(6) DESCRIPTION	(7)	(8)
(a) FIG NO.	(b) ITEM NO.	SMR CODE	FEDERAL STOCK NUMBER	PART NUMBER	FSCM	USABLE ON CODE	U/M	QTY INC IN UNIT
						GROUP 101 SLIDE GROUP		
N	B-2	1	PAFZZ	1005-00-501-3201	3013201	19204	EA	1
N	B-2	2	PAFZ	5360-00-501-3200	5013200	19204	EA	1
N	B-2	3	PAFZZ	1005-00-600-8597	4008597	19204	EA	1
N	B-2	4	PAFZZ	3120-00-600-8594	6008596	19204	EA	1
N	B-2	5	PAFZZ	1005-00-722-3849	7791193	19204	EA	1
N	B-2	6	PAOZZ	5315-00-501-3199	5013199	19204	EA	1
N	B-2	7	PAOZZ	1005-00-501-3198	5013198	19204	EA	1
N	B-2	8	PAOZZ	1005-00-501-3205	5013205	19204	EA	1
N	B-2	9	PAOZZ	1005-00-600-8599	6008599	19204	EA	1
N	B-2	10	PAOZZ	5360-00-501-3204	3013204	19204	EA	1
N	B-2	11	PAFZ	1005-00-600-8598	6008598	19204	EA	1
N	B-2	12	PAHZ	1005-00-876-4033	7790353	19204	EA	1
N	B-2	13	PAPZZ	1005-00-501-3196	5013196	19204	EA	1
N	B-2	14	PAFZZ	1005-00-501-3197	5013197	19204	EA	1
N	B-2	15	XA		7703149	19204	EA	1

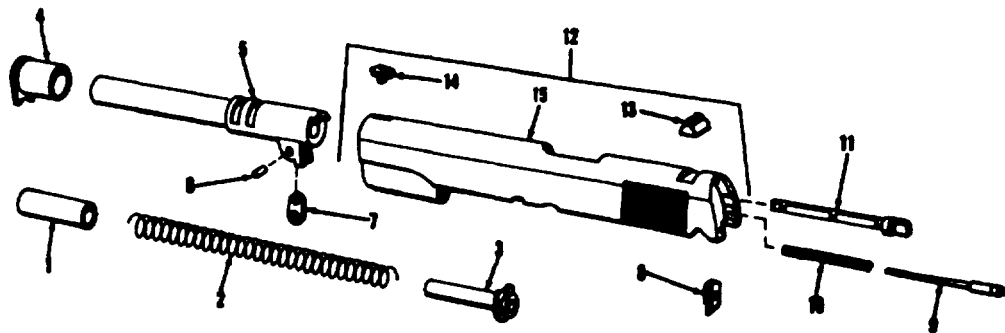

Figure B-2. Slide group.

WE 17399

(1) ILLUSTRATION		(2)	(3)	(4)	(5)	(6) DESCRIPTION	(7)	(8)
(a) FIG NO.	(b) ITEM NO.	SMR CODE	FEDERAL STOCK NUMBER	PART NUMBER	FSCM	USABLE ON CODE	U/M	QTY INC IN UNIT
						GROUP 0102 RECEIVER GROUP		
N	B-3	1	PAFZZ	1005-00-550-3840	5503840	19240	SAFETY, SMALL ARMS	EA 1
N	B-3	2	PAFZ	5315-00-501-3212	5013212	19204	PIN, MAINSPRING HOUSING	EA 1
N	B-3	3	PAFZZ	1005-00-650-1828	6501828	19204	SAFETY, GUN GRIP	EA 1
N	B-3	4	PAFZZ	1005-00-556-4058	5564058	19204	HOUSING, ASSEMBLY, MAINSPRING	EA 1
N	B-3	5	PAFZZ	5315-00-844-4790	MS16562-25	96906	PIN, SPRING, TUBULAR, SLOT 4 ED, BOTH ENDS CHAN, S, CD-PLTD, 0.093 DIA, 0.0500 LG, 0.022 STK THK	EA 1
N	B-3	6	PAFZZ	1005-00-501-3214	5013214	19204	LOOP, LANYARD U SHAPE, 0.107 STK DIA, 1/2 LG (MAINSPRING HOUSING)	EA 1
N	B-3	7	XA		5503841	19204	HOUSING, MAINSPRING	EA 1
N	B-3	8	PAFZZ	5315-00-501-3216	5013219	19204	PIN, STRAIGHT, HEADED FL-CK-HD, S, 0.0084 SHANK DIA, 0.0369 LG (MAINSPRING HOUSING)	EA 1
N	B-3	9	PAFZZ	5315-00501-3209	5013209	19204	PIN, STRAIGHT, HEAD FL-FIL-HD, S, 0.174 SHANK DIA., 0.0608 MAINSPRING CAP	EA 1
N	B-3	10	PAFZ	5360-00-501-3206	5013206	19204	SPRING, HELICAL, COMPRESSION 5.21.5 COILS, HOUSING ASSY	EA 1
N	B-3	11	PAFZ	1005-00-501-3215	5013213	19204	PLUNGER, DETENT	EA 1
N	B-3	12	PAOZZ	5360-00-600-8402	6008402	19204	SPRING, SEAR	EA 1
N	B-3	13	PAFZZ	5315-00-501-3204	5013206	19204	PIN, STRAIGHT, HEADED FL-CK-HD 5.0.157 MAX SHANK DIA., 0.784 LG UNDER HD (HAMMER)	EA 1
N	B-3	14	PAFZZ	1005-00-980-1743	7790803	19204	HAMMER, FIRING, SMALL ARMS	EA 1
N	B-3	15	PAFZZ	5315-00-501-3207	5013207	19204	PIN, STRAIGHT, HEADLESS S, PHOS-FIN., 0.96 MAX DIA., 0.305 O/A LG HAMMER STRUT:	EA 1
N	B-3	16	PAOZZ	1005-00-600-8600	6008600	19204	STRUT, HAMMER	EA 1
N	B-3	17	PAFZZ	5315-00-501-3211	5013211	19204	PIN, STRAIGHT, HEADED FL-CK-HD, S, 0.110 MAX SHANK DIA., 0.700 MAX LG UNDER HD (SEAR)	EA 1
N	B-3	18	PAFZZ	1005-00-592-9974	7268068	19204	SEAR	EA 1
N	B-3	19	PAFZZ	1005-00-400-8603	6008603	19204	DISCONNECTOR, RECEIVER ASSEMBLY	EA 1
N	B-3	20	PAFZZ	1005-00-600-8609	6008609	19204	CATCH, MAGAZINE	EA 1
N	B-3	21	PAFZ	1005-00-501-3218	5013216	19204	LOCK, MAGAZINE CATCH	EA 1
N	B-3	22	PAFZZ	5360-00-501-3217	5013217	19204	SPRING, HELICAL, COMPRESSION 13 COILS MAGAZINE CATCH	EA 1
N	B-3	23	PAFZZ	1005-00-614-7780	6147780	19204	TRIGGER STL, PHOS-CTO, 2.26 LOA, 0.91 W	EA 1
N	B-3	24	5315-00-501-3201		5013205	19204	PIN, STRAIGHT, HEADLESS 5/16 S, 0.063 MAX DIA, 39/64 O/A LG (EJECTOR)	EA 1
N	B-3	25	PAFZZ	1005-00-903-8192	11010485	19204	EJECTOR, CARTRIDGE	EA 1
N	B-3	26	PAOZZ	5305-00-601-9023	6019023	19204	SCREW, MACHINE FIL-HD, S, PHDS-CTD, 0.150-5 DNS, 0.260 O/A LG GRIP:	EA 4
N	B-3	27	PAOZ	1005-00-556-4063	5564063	19204	GRIP, PISTOL LH, PLASTIC, CHECKERED	EA 1
N	B-3	28	PAOZZ	1005-00-556-4062	5564062	19204	GRIP, PISTOL RH, PLASTIC, CHECKERED	EA 1
N	B-3	29	PAFZZ	1005-00-601-9022	6019022	19204	BUSHING, STOCK SCREW RECEIVER ASSY	EA 1
N	B-3	30	PAFZZ	1005-00-501-3195	5013195	19204	PLUNGER, SAFETY	EA 1
N	B-3	31	PAOZZ	5360-501-3194	5013194	19204	SPRING, HELICAL, COMPRESSION 14-1/2 COILS, PLUNGER	EA 1
N	B-3	32	PAFZZ	1005-00-501-3193	5013193	19204	PLUNGER, SLIDE STOP	EA 1
N	B-3	33	PAFZZ	1005-00-600-8594	6008594	19204	TUBE PLUNGER	EA 1
N	B-3	34	XA		6535359	19204	RECEIVER	EA 1

SECTION III. SPECIAL TOOLS LIST

(1) ILLUSTRATION		(2)	(3)	(4)	(5)	(6)	(7)	(8)
(a) FIG NO.	(b) ITEM NO.	SMR CODE	FEDERAL STOCK NUMBER	PART NUMBER	FSCM	DESCRIPTION USABLE ON CODE	U/M	QTY INC IN UNIT
N	B-4	1	PAFZZ	1095-00-592-6491	7791466	GROUP 02 EQUIPMENT AUTHORIZED FOR UNIT MAINTENANCE		
N	B-4	2	PAFZZ	1095-00-973-2353	7791527	HOLSTER, PISTOL HIP, M1916 (BLACK) HOLSTER, PISTOL SHOULDER, MT (BLACK)	EA EA	1 1
N			PAOZ	1005-00-200-3945	5019316	GROUP 03 TOOLS AND EQUIPMENT SWAB, SMALL ARMS CLEANING COTTON, 2-1/2 SQ #1000	EA	1
N			PAFHD	4933-00-773-0364	8426358	IN PKG: TOOL SET, DIRECT AND GENERAL SUPPORT MAINTENANCE, BASE C SMALL ARMS	EA	1

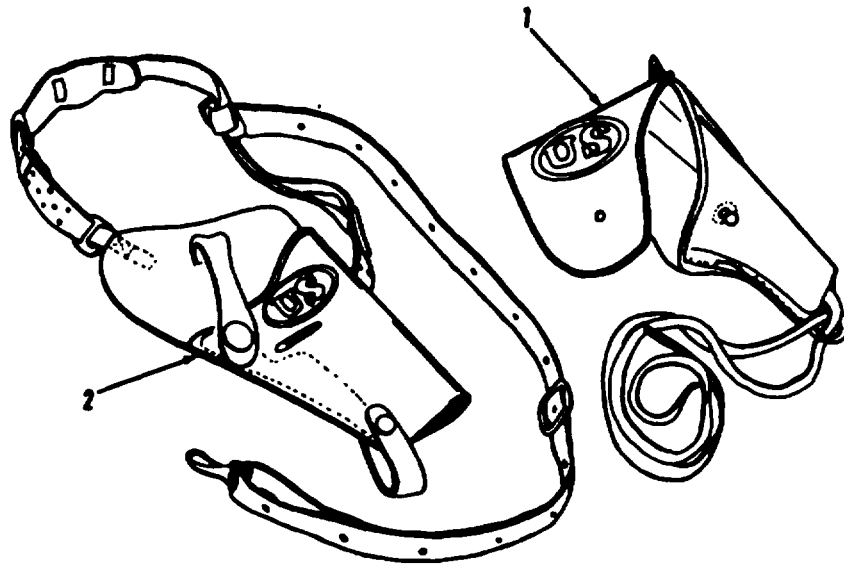

Figure B-4. Special equipment.

WE 910574

SECTION IV. NATIONAL STOCK NUMBER AND PART NUMBER INDEX

NATIONAL STOCK NUMBER	FIGURE NO.	ITEM NO.	NATIONAL STOCK NUMBER	FIGURE NO.	ITEM NO.
1005-00-288-3565	B-4	80	1005-00-556-4058	B-3	4
1005-00-501-3193	B-3	32	1005-00-556-4062	B-3	28
5360-00-501-3194	B-3	31	1005-00-556-4063	B-3	27
1005-00-501-3195	B-3	30	1095-00-592-6491	B-4	1
1005-00-501-3196	B-2	13	1005-00-592-9974	B-3	18
1005-00-501-3197	B-2	14	1005-00-600-8594	B-3	33
1005-00-501-3198	B-2	7	1005-00-600-8595	B-1	2
5315-00-501-3199	B-2	6	3120-00-600-8596	B-2	4
5360-00-501-3200	B-2	2	1005-00-600-8597	B-2	3
1005-00-501-3201	B-2	1	1005-00-600-8598	B-2	11
5315-00-501-3203	B-3	24	1005-00-600-8599	B-2	9
5360-00-501-3204	B-2	10	1005-00-600-8600	B-3	16
1005-00-501-3205	B-2	8	5360-00-600-8602	B-3	12
5315-00-501-3206	B-3	13	1005-00-600-8603	B-3	19
5315-00-501-3207	B-3	15	1005-00-600-8609	B-3	20
5360-00-501-3208	B-3	10	3120-00-601-9022	B-3	29
5315-00-501-3210	B-3	8	5305-00-601-9023	B-3	26
5315-00-501-3211	B-3	17	1005-00-614-7780	B-3	23
5315-00-501-3212	B-3	2	1005-00-650-1828	B-3	3
1005-00-501-3213	B-3	11	1005-00-722-3849	B-2	5
1005-00-501-3214	B-3	6	4933-00-775-0366		
5360-00-501-3217	B-3	22	5315-00-844-4790	B-3	5
1005-00-501-3218	B-3	21	1005-00-876-4033	B-2	12
1005-00-550-3840	B-3	1	1005-00-903-8192	B-3	25
1005-00-550-8694	B-1	1	1095-00-973-2353	B-4	2
			1005-00-980-1743	B-3	14

PART NUMBER	FSCM	FIG. NO.	ITEM NO.	PART NUMBER	FSCM	FIG. NO.	ITEM NO.
MS16562-25	96906	B-3	5	5508694	19204	B-1	1
11010485	19204	B-3	25	5564058	19204	B-3	4
5013193	19204	B-3	32	5564062	19204	B-3	28
5013194	19204	B-3	31	5564063	19204	B-3	27
5013195	19204	B-3	30	6008594	19204	B-3	33
5013196	19204	B-2	13	6008595	19204	B-1	2
5013197	19204	B-2	14	6008596	19204	B-2	41
5013198	19204	B-2	7	6008597	19204	B-2	3
5013199	19204	B-2	6	6008598	19204	B-2	11
5013200	19204	B-2	2	6008599	19204	B-2	9
5013201	19204	B-2	1	6008600	19204	B-3	16
5013203	19204	B-3	24	6008602	19204	B-3	12
5013204	19204	B-2	10	6008603	19204	B-3	19
5013205	19204	B-2	8	6008609	19204	B-3	20
5013206	19204	B-3	13	6019022	19204	B-3	29
5013207	19204	B-3	15	6019023	19204	B-3	26
5013208	19204	B-3	10	6147780	19204	B-3	23
5013209	19204	B-3	9	6501828	19204	B-3	3
5013210	19204	B-3	8	6535359	19204	B-3	34
5013211	19204	B-3	17	7265655	19204		
5013212	19204	B-3	2	7265655	19204	B-1	
5013213	19204	B-3	11	7268068	19204	B-3	18
5013214	19204	B-3	6	7790314	19204	B-2	15
5013217	19204	B-3	22	7790353	19204	B-2	12
5013218	19204	B-3	21	7790803	19204	B-3	14
5019316	19204	B-4	80	7791193	19204	B-2	5
5503840	19204	B-3	1	7791466	19204	B-4	1
5503841	19204	B-3	7	7791527	19204	B-4	2
				8426358	19204		

Change in force: C1, C2 and C3

TM 9-1005-211-35
C 3

Change }
No. 3 }

HEADQUARTERS
DEPARTMENT OF THE ARMY
Washington, D.C. 17 December 1970

**Direct Support, General Support, and Depot Maintenance Manual
Including Repair Parts and Special Tools Lists**

**PISTOL CAMBER .45, AUTOMATIC:
M1911A1, WITH HOLSTER, HIP, W/E
(1006-673-7965)**

**PISTOL CALIBER .45, AUTOMATIC:
M1911A1, WITH HOLSTER, SHOULDER, W/E
(1005-561-2003)**

CHANGE }
No. 2 }

HEADQUARTERS
DEPARTMENT OF THE ARMY
WASHINGTON, D. C., *24 June 1969*

Direct Support, General Support, and Depot Maintenance Manual

Including Repair Parts and Special Tool Lists

PISTOL, CALIBER .45, AUTOMATIC:

M1911A1, WITH HOLSTER, HIP, W/E

(1005-673-7965)

PISTOL, CALIBER 45, AUTOMATIC:

M1911A1, WITH HOLSTER, SHOULDER, W/E

(1005-561-2003)

TM 9-1006-211-36, 4 April 1968, is changed as follows:

Table 2-3. Inspection Procedures - Continued

Inspection of Material in Hands of Troops		Direct and General Support Inspections		Pre-assembly or Inspector	Action	Reference
Spot checks	Comments	Initial	In-process			
.	GENERAL	.
X	X			X	SPECIFIC (Superseded)	
X	X			X	Safety tests and disconnector test.	TM 9-1005-211-12 Para 3-5
					Trigger pull: Max. 6.5 pounds Min. 5.0 pounds	
X	X	X		X	Magazine Assembly	TM 9-1005-211-12
X	X	X	X	X	Slide Group	
					Inspect barrel (5, fig B-2) for burrs on exterior and interior rim of the muzzle. Inspect for pitting, bulges and sharpness of lands. Barrel must be straight, as determined visually, clean and free of corrosion. Pits in the chamber are allowable if they are not large enough to cause extraction difficulties. Pits as wide as a land or groove and less than 1/4 inch are allowable. Barrels containing pits as indicated in Figure 2-5, will be rejected. Scattered or uniformly fine pits or pits in a densely pitted area are allowable. Surface tool marks and scratches are acceptable regardless of length. Tool marks will appear on lines running laterally in the grooves or may run spirally across the top of lands. Definitely ringed bores or bores ringed sufficiently to bulge the outside surface of the barrel are cause for rejection. However, faint rings or shadowy depressions do not indicate an unserviceable barrel and should not be cause for rejection. Barrels will be rejected if worn enough to affect sharpness of the lands. Pits cutting into lands are acceptable, within the limitations described above. Lands that appear dark due to coating or gilding metal from projectiles should not be cause for rejection.	Fig 2-5
X	X	X	X	X	Inspect the barrel bearing for burrs and elongation.	4, fig B-2
X	X	X	X	X	Inspect the slide for breaks and cracks especially around the ejector port. Inspect the interior grooves and ejector port of slide for excessive wear or burrs. Check for loose front or rear sights.	12, fig B-2
X	X	X	X	X	The ejector will be examined for burrs, cracking and looseness. If any of these is evidenced the ejector will be repaired or replaced.	
X	X	X	X	X	Inspect the firing pin for wear or shortness. The pin, as manufactured, has an overall length of 2.290 to 2.296 inches.	19, fig B-2

Inspection of Material in Hands of Troops		Direct and General Support Inspections		Precombatation Inspections	Action	Reference
Spot check	Command	Initial	In-process			
X	X	X	X	X	Inspect the recoil and firing pin springs for damage or deformity. the recoil spring must exhibit not less than 6 or more than 6 1/4 inches overall length. The number of coils, not less than 28 or more than 32 including half coils. Spring must not exhibit weakness, distortion or kinks. There will be no flat surface on the contour. Uniform diameter of all coils is permissible. A "flat" appearance on either end of the half coil is not required.	3 and 10, fig B-2
X	X	X	X	X	Inspect the extractor for wear, weakness, broken lip or deformation.	11, fig B-2
X	X	X	X	X	Inspect the recoil spring plug, recoil spring guide, firing pin stop, barrel link and pin for bars or distortions. <i>Note. Recoil spring plugs will not be declared unserviceable when the retaining tab is damaged or broken. There is no change in weapon functioning or impairment of personnel safety when tabless plugs are utilized.</i>	Fig B-2
.

Section II. REPAIR PARTS

Page No.	Action	(1) Source Maint and Recov Code			(2) Federal Stock No.	(3) Description	(4) Unit of Meas	(5) Qty Inc in Unit	(6) 30-Day DS Maint Allowance			(7) 30-Day GS Maint Allowance			(8) 1-Yr Alw Per 100 Equip Contgcy	(9) Depot Maint Alw Per 100 Equip	(10) Illustration	
		(a) Source	(b) Maint	(c) Recov					(a) 1-20	(b) 21-50	(c) 51-100	(a) 1-20	(b) 21-50	(c) 51-100			(a) Fig. No.	(b) Item No.
B-4	Change: column 1b column 1a column 10b	X11	H		1005-600-8598	SLIDE GROUP RECEIVER GROUP EXTRACTOR ***												11
B-5	Change: column 1b and		M		1005-556-4058	HOUSING, ***						.	.	.				
Section III. SPECIAL TOOLS, TEST AND SUPPORT EQUIPMENT																		
B-9	Change column 3				5220-731-9916	2 - GAGE, *** 0.7055 OD 7319916 (19205)												

TECHNICAL MANUAL }
No. 9-1005-211-35

HEADQUARTERS,
DEPARTMENT OF THE ARMY
WASHINGTON, DC., 4 April 1968

PISTOL, CALIBER .45, AUTOMATIC M1911A1

This manual is current as of 6 February 1968

	Paragraphs	Page
CHAPTER 1. INTRODUCTION		
Section I. General	1-1,1-2	1-1
II. Description and data	1-3	1-1
CHAPTER 2. DIRECT SUPPORT, GENERAL SUPPORT AND DEPOT MAINTENANCE INSTRUCTIONS		
Section I. Repair parts, special tools and equipment	2-1, 2-2	2-1
II. Troubleshooting.....	2-3	2-3
III. Inspection.....	2-4,2-6	2-4
IV. Depot maintenance instructions	2-7	2-7
CHAPTER 3. REPAIR INSTRUCTIONS		
Section I. General Maintenance	3-1,3-3	3-1
II. Maintenance of Caliber .45, Automatic, Pistol, M1911A1.....	3-4	3-1
III. Repair standards	3-5,3-6	3-3
CHAPTER 4. FINAL INSPECTION.....	4-1,4-6	4-1
APPENDIX A. REFERENCES		A-1
B. DIRECT SUPPORT, GENERAL SUPPORT AND DEPOT MAINTENANCE REPAIR PARTS AND SPECIAL TOOLS LISTS		
Repair Parts For:		
Major Groups and Assemblies		B-4
Slide Group		B-4
Receiver Group.....		B-5

This manual supersedes TM 9 1005-211-34, 22 June 1964, including C1, 13 April 1967, and TM 9-1005-211-35P, 29 April 1964.

CHAPTER 1

INTRODUCTION

Section I. GENERAL

1-1. Scope

These instructions are in accordance with the MAC and are published for the use of direct support, general support, and depot maintenance personnel maintaining the Caliber .45, Automatic, Pistol M1911A1. They provide information on the maintenance of the equipment which is beyond the scope of the tools, equipment, personnel or supplies normally available to operator's and organizational maintenance.

1-2. Forms and Records

- a. *General.* DA Forms and procedures used

for equipment maintenance will be only those prescribed in TM 38-750, Army Equipment Record Procedures.

b. Recommendations for Equipment Publication Improvements. Report of errors, omissions, and recommendation for improving this publication by the individual user is encouraged. Reports should be submitted on DA Form 2028 (Recommended Changes to DA Publication) and forwarded direct to the Commanding General, Headquarters, U.S. Army Weapons Command, ATTN: AMSWE-SMM-P, Rock Island Arsenal, Rock Island, Illinois 61201.

Section II. DESCRIPTION AND DATA

1-3. Description and Tabulated Data

Refer to TM 9-1005-211-12.

DIRECT SUPPORT, GENERAL SUPPORT, AND DEPOT MAINTENANCE INSTRUCTIONS

Section I. REPAIR PARTS, SPECIAL TOOLS AND EQUIPMENT

2-1. Repair Parts Special Tools and Equipment

Refer to appendix B.

2-2. Improvised Tools

Refer to table 2-1.

Table 2-1. Improvised Tools

Item	References		Required for
	Figure	Use	
Fixture, riveting front sight	Fig. 2-1, 2-2	Fig. 3-1	To rivet front sight in place on elide assembly.
Tool, staking bushing	Fig. 2-3	Fig. 3-2	To stake bushing in receiver.
Tool, staking plunger tube	Fig. 2-4	Fig. 3-3	To stake plunger tube in receiver.

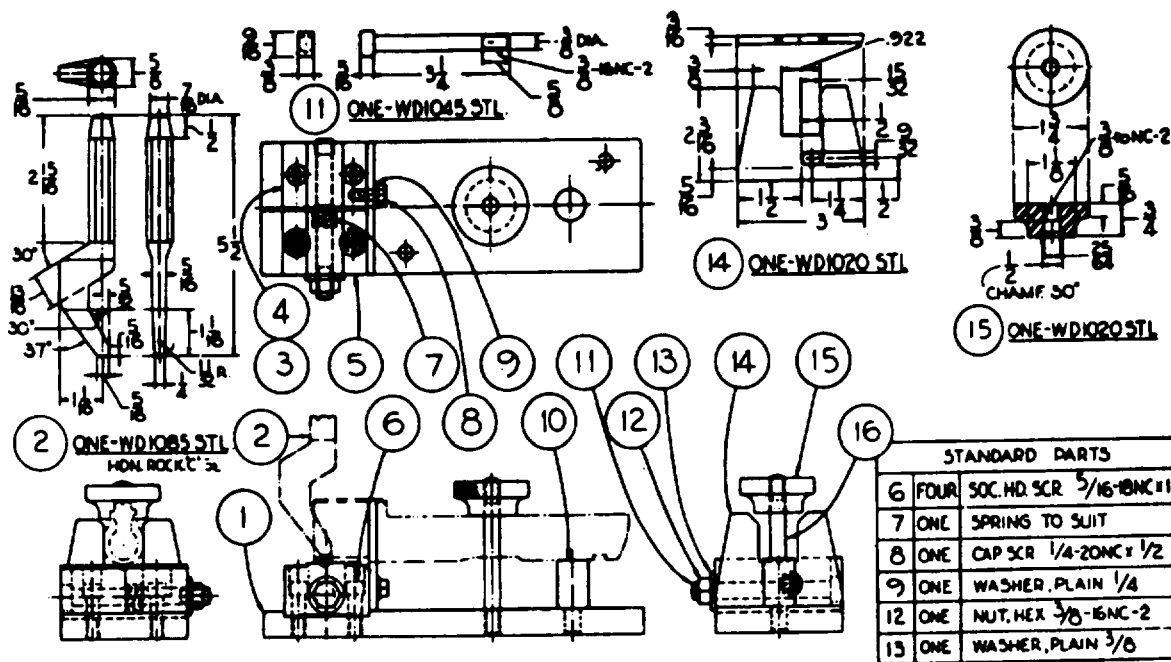

SHEET 1 OF 2

Figure 2-1. Improvised fixture for riveting front sight, (1 of 2)

WE 17383

Section III. INSPECTION

2-4. General

This section provides specific instructions for guidance during inspection by direct and general support maintenance personnel of materiel in the hands of troops in the field, in direct and general support shops, and in alerted units scheduled for over-seas duty. Inspections are made for the purpose of: (1) determine the condition of an item as to serviceability, (2) recognizing conditions that would cause failure, (8) assuring proper application of maintenance policies at prescribed levels, and (4) determine the ability of a unit to accomplish its maintenance and supply missions.

2-5. Categories of Inspection

Refer to AR 760-8.

2-6. Inspection Procedures

Warning. Before starting an inspection, be sure to clear the weapon. **DO NOT** actuate the trigger until the weapon has been cleared. Inspect the chamber, to insure that it is empty, and check to see that no ammunition is in position to be introduced (magazine). Avoid having live ammunition in the vicinity of work area.

a. Refer to table 2-3 and TM 9-1005-211-12.

b. Complete inspection of all parts is not always necessary, good judgment should be exercised pertaining to the degree of inspection of integral parts within assemblies.

Table 2-3. Inspection Procedure.

Inspection of materiel in hands of troops		Direct and general support inspections		Presubscription inspection	Action	Reference
Spot check	Command	Initial	In-process			
x	x	x	-----	x	GENERAL	
x	x	-----	-----	x	Determine serviceability.	
x	x	-----	-----	x	Determine causes of mechanical and functional difficulties that troops may be having.	
x	x	-----	-----	x	Determine if all authorized modifications have been applied, and that no unauthorized alterations have been made. Check the index in DA Pam 310-4 and the current MWO files for any MWO's printed after publication.	
x	x	-----	-----	x	Determine that no work beyond the scope of the unit is being attempted.	
x	x	-----	-----	x	Instruct personnel in proper preventive maintenance procedures, where found inadequate.	
x	x	-----	-----	x	Check on completeness of organizational maintenance allowances and procedures for obtaining replenishments.	
x	x	-----	-----	x	Check legibility of serial number.	
x	x	-----	-----	x	Check general appearance of pistol and holster.	
x	x	-----	-----	x	Check storage conditions of supplies and ammunition.	
x	x	-----	-----	x	Initiate a thorough report on materiel on "deadline" with reason therefore, for further appropriate action.	
x	x	-----	-----	x	Report to responsible officer any carelessness, negligence, unauthorized modifications or tampering. Report to be accompanied by recommendations for correcting unsatisfactory conditions.	

Table 2-3. Inspection Procedures-Continued

Inspection of material in hands of troops		Direct and general support inspections		Premarketing inspection	Action	Reference
Spot check	Command	Initial	In-process			
x	x	-----	-----	x	SPECIFIC Safety tests and disconnecter test. Trigger Pull: maximum—6.5 pounds minimum—5.0 pounds	TM 9-1006-211-12 Par 3-5
x	x	x	-----	x	Magazine assembly Slide Group	TM 9-1005-211-12
x	x	x	x	x	Inspect the barrel (6. fig B-2) for burs on exterior and interior rim of the muzzle. Inspect for pitting, bulges, and sharpness of lands. Barrel must be straight, as determined visually, clean and free of corrosion. Pits in the chamber are allowable if they are not large enough to cause extraction difficulties. Pits as wide as a land or groove and less than three-eighths are allowable. Barrels containing pits, as indicated in figure 2-5, will be rejected. Scattered or uniformly fine pits or fine pits in a densely pitted area are allowable. Tool marks or scratches are accepted regardless of length. Tool marks will appear on lines running laterally in the grooves or may run spirally across the top of lands. Definitely ringed bores or bores ringed sufficiently to bulge the outside surface of the barrel are cause for rejection. However, faint rings or shadowy depressions do not indicate an unserviceable barrel and should not be cause for rejection. Barrels will be rejected if worn sufficiently to affect sharpness of the lands. However, pits cutting into lands are acceptable if within the limitations described above. Lands that appear dark due to coating or gilding metal from projectiles should not be cause for rejection.	Fig 2-5
x	x	x	x	x	Inspect the barrel bearing for burs and excessive wear.	4, fig B-2
x	x	x	x	x	Inspect slide for breaks or cracks, especially around the ejector port. Inspect the interior grooves and ejector port of slide for excessive wear or burs. Check for loose front or rear sights.	12, fig B-2
x	x	x	x	x	Inspect the firing pin for wear or shortness. The pin, as manufactured, has an overall length of 2.290 to 2.296 inches.	9, fig B-2
x	x	x	x	x	Inspect the recoil and firing pin springs for damage or deformity. The recoil spring must be 6-1/2 inches free length.	3 and 10, fig B-2
x	x	x	x	x	Inspect the extractor for wear, weakness, broken lip or deformation.	11, fig B-2
x	x	x	x	x	Inspect the recoil spring plug, recoil spring guide, firing pin stop, barrel link and pin for burs or distortions.	Fig B-2

Table 2-3. Inspection Procedure - Continued

Inspection of materiel in hands of troops		Direct and general support inspections		Frembarbation inspection	Action	Reference
Spot check	Command	Initial	In-process			
X	X	---	---	X	SPECIFIC Safety tests and disconnecter test. Trigger Pull: maximum—6.5 pounds minimum—5.0 pounds	TM 9-1006-211-12 Par 3-5
X	X	X	---	X	Magazine assembly Slide Group	TM 9-1005-211-12
X	X	X	X	X	Inspect the barrel (6. fig B-2) for burs on exterior and interior rim of the muzzle. Inspect for pitting, bulges, and sharpness of lands. Barrel must be straight, as determined visually, clean and free of corrosion. Pits in the chamber are allowable if they are not large enough to cause extraction difficulties. Pits as wide as a land or groove and less than three-eighths are allowable. Barrels containing pits, as indicated in figure 2-5, will be rejected. Scattered or uniformly fine pits or fine pits in a densely pitted area are allowable. Tool marks or scratches are accepted regardless of length. Tool marks will appear on lines running laterally in the grooves or may run spirally across the top of lands. Definitely ringed bores or bores ringed sufficiently to bulge the outside surface of the barrel are cause for rejection. However, faint rings or shadowy depressions do not indicate an unserviceable barrel and should not be cause for rejection. Barrels will be rejected if worn sufficiently to affect sharpness of the lands. However, pits cutting into lands are acceptable if within the limitations described above. Lands that appear dark due to coating or gilding metal from projectiles should not be cause for rejection.	Fig 2-5
X	X	X	X	X	Inspect the barrel bearing for burs and excessive wear.	4, fig B-2
X	X	X	X	X	Inspect slide for breaks or cracks, especially around the ejector port. Inspect the interior grooves and ejector port of slide for excessive wear or burs. Check for loose front or rear sights.	12, fig B-2
X	X	X	X	X	Inspect the firing pin for wear or shortness. The pin, as manufactured, has an overall length of 2.290 to 2.296 inches.	9, fig B-2
X	X	X	X	X	Inspect the recoil and firing pin springs for damage or deformity. The recoil spring must be 6-1/2 inches free length.	3 and 10, fig B-2
X	X	X	X	X	Inspect the extractor for wear, weakness, broken lip or deformation.	11, fig B-2
X	X	X	X	X	Inspect the recoil spring plug, recoil spring guide, firing pin stop, barrel link and pin for burs or distortions.	Fig B-2

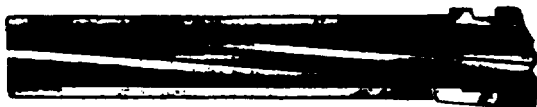

EXAMPLE 1. INTERIOR OF BARREL SHOWING SLIGHT PITTING AND SHARP LANDS - CUTAWAY VIEW,

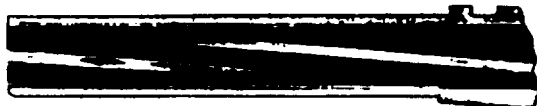

EXAMPLE 2. INTERIOR OF BARREL SHOWING PITTING AND DULL LANDS - CUTAWAY VIEW.



EXAMPLE 3. INTERIOR OF BARREL SHOWING PITTING, WORN LANDS AND BURS- CUTAWAY VIEW .

WE 17388

Figure 2-5. Barrel assembly inspection criteria.

SECTION IV. DEPOT MAINTENANCE INSTRUCTIONS

2-7. General

WE-SMM-SA, Rock Island Arsenal, Rock Island, Illinois 61201.

a. For depot maintenance instructions contact the Commanding General, Headquarters, U.S. Army Weapons Command, ATTN: AMS-

b. Repair parts, special tools and equipment are listed in appendix B of this manual.

CHAPTER 3

REPAIR INSTRUCTIONS

Section I. GENERAL MAINTENANCE

3-1. General

This section provides instructions on general maintenance procedures.

3-2. General Repair Methods

a. *Disassembly and Assembly) Procedures.*

(1) In disassembling the pistol, remove the major groups and assemblies (fig B-1) whenever possible. Groups and assemblies may be disassembled, as necessary, into individual parts.

(2) Complete disassembly of a unit is not always necessary in order to make a required replacement or repair. Good judgment should be exercised to keep disassembly and assembly operations to a minimum.

(3) During assembly, assemblies and groups should be assembled first, then installed to form a complete unit. Lubricate parts before

assembly as indicated in TM 9-1005-211-12.

b. *Replacement of Parts.*

(1) Parts will be replaced when unserviceable.

(2) When assembling a unit, replace spring pins, if available. If screws, nuts, washers, and retainers are damaged they will be replaced.

(3) All springs should be replaced if they are broken, deformed, fail to function properly, or fail to meet specific requirements.

(4) If a new part is not available, a reconditioned part may be substituted. Such reconditioned parts should be examined carefully to determine their serviceability.

3-3. Cleaning

Refer to TM 9-1005-211-12 for detailed cleaning procedures.

Section II. MAINTENANCE OF CALIBER .45,

AUTOMATIC, PISTOL, M1911A1

3-4. General

a. For removal of major groups and assemblies refer to TM 9-1005-211-12 and figure B-1.

b. Refer to table 3-1 for specific maintenance instructions.

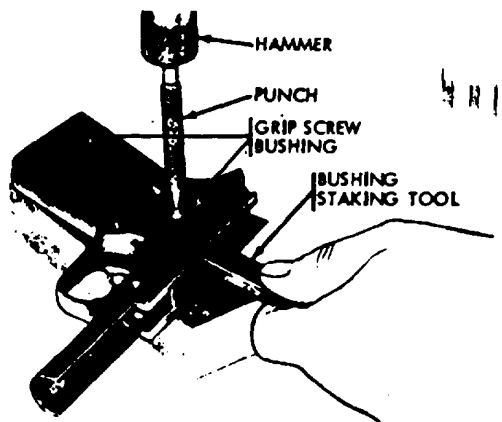

WE 17393

Figure 3-2. Installing and staking grip screw, bushings on receiver, utilizing improvised tool for staking grip screw bushings.

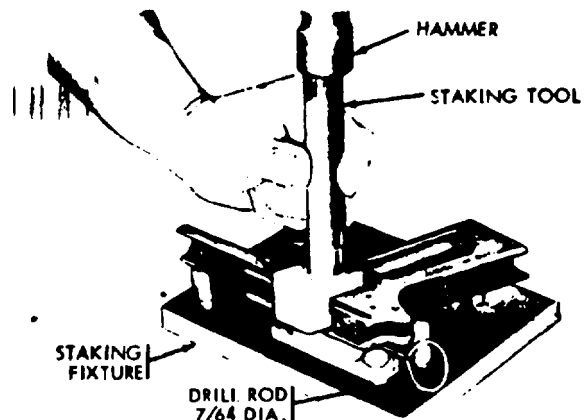

WE 17392

Figure 3-3. Installing and staking of plunger tube on receiver, utilizing improvised tool for staking plunger tube.

SECTION III. REPAIR STANDARDS

3-5. Trigger Pull Test

After final assembly of the pistol, check the trigger pull using trigger pull measuring fixture 7274758 (fig 3-4) in accordance with instructions indicated below.

Step 1. With the safety unlocked, rest the weight on the floor and hook the notched portion of the rod over the center portion of the trigger.

Note. Make certain the rod does not contact or rub any portion of the pistol and that rod and barrel are parallel. Empty magazine must be installed when checking the trigger pull.

Step 2. Depress grip safety and carefully raise the weight from the floor. When using the 6 pound weight (minimum), the trigger should not release the hammer. When using the 6.6 pound weight (maximum), the trigger should release the hammer.

Caution: A slow and steady lift must be utilized to assure a true and accurate check.

3-6. Correcting Trigger Pull

Caution. While stoning, critical dimensions should not be altered.

a. *Trigger Pull Too Light.* This is evidence of a worn cocking notch on the hammer, worn or damaged sear, or a weak helical compression housing spring. Examine the components for wear or damage. If trigger pull cannot be corrected by stoning, replace with new components, as required.

b. *Trigger Pull Exercise.* This is evidence of burrs or surface irregularities on the hammer full-cock notch or sear. A helical compression housing spring that is damaged or too strong and/or interference or binding between the mating surfaces of the pertinent parts within the receiver group are other probable causes. If the trigger pull cannot be corrected by stoning, replace with new components, as required.

c. *Creep in Trigger.* Creep is defined as a perceptible movement of the trigger after the slack has been taken up and before the hammer is released. It is caused by rough or uneven mating surfaces of the sear, hammer, and disconnecter and also by unserviceable sear and hammer pins. If the creep cannot be corrected by stoning, replace with new components, as required.

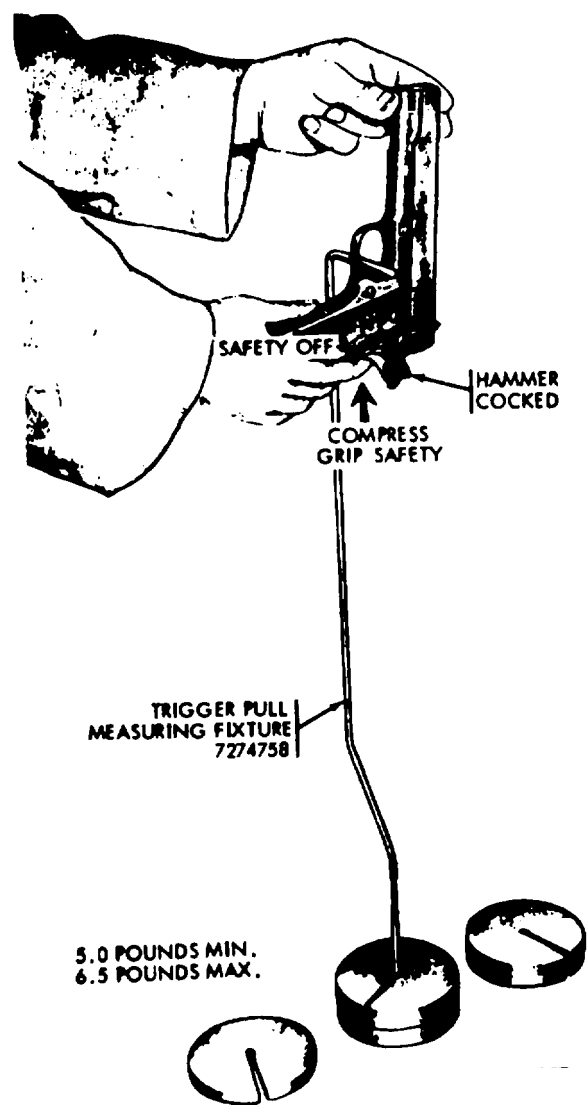

WE 17387

Figure 3-4. Checking trigger pull.

CHAPTER 4

FINAL INSPECTION

4-1. Visual Inspection

For specific visual inspection procedure refer to table 2-3.

4-2. General Functional Inspection

Refer to TM 9-1005-211-12 for procedures in conducting the following inspections.

- a. Check functioning of safety.
- b. Check functioning of grip safety.
- c. Check functioning of hammer and sear.
- d. Check functioning of disconnecter.

4-3 Hand Function Test

The following hand function test is performed by following the four steps listed below:

- Step 1. Place three dummy cartridge in magazine (fig. 4-1, step 1). Insert magazine in river group. Release slide stop. This action would cause barrel and slide group to move forward. At the same time, a dummy cartridge

will be stripped from magazine into chamber of the weapon.

- Step 2. Release safety (Fig 4-1, step 2).
- Step 3. Squeeze trigger, allowing hammer to fall (fig. 4-1, step 8). Continue test until third cartridge has been ejected from the pistol, simulating dry firing.
- Step 4. When last cartridge is ejected, slide group should remain locked in open position by slide stop (fig 4-1, step 4).

4-4. Function and Firing Tests

Pistols that have been repaired should be function fired, whenever possible, to assure proper operation.

4-5. Corrective Action

Pistols that fail to meet any of the above functional or firing tests are to be corrected by replacement of defective components.

4-6. Completion of Inspection

Upon completion of the final inspection, pistols will be cleaned and lubricated.

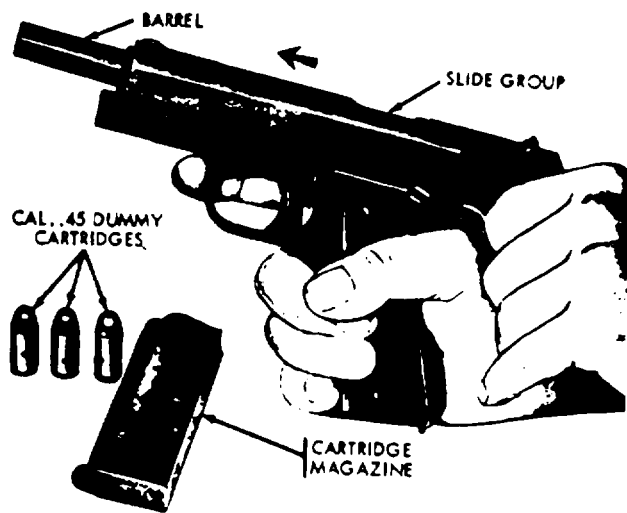

STEP 1. POSITION OF HANDS WHEN LOADING WEAPON - LEFT FRONT VIEW.

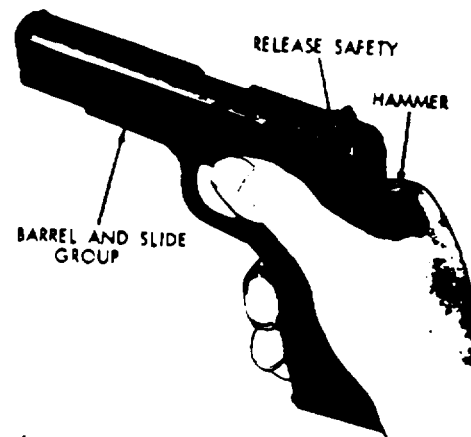

STEP 2. HAMMER COCKED - READY TO BEGIN FUNCTION FIRING.

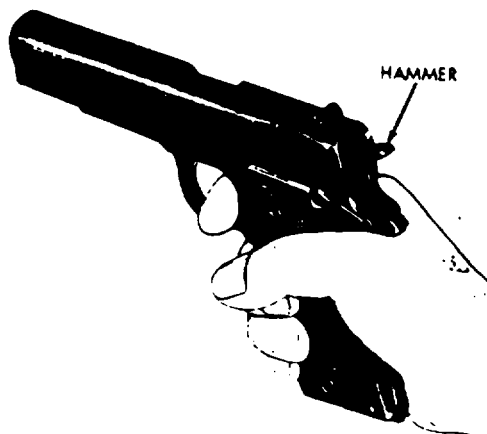

STEP 3. WEAPON IN BATTERY POSITION.

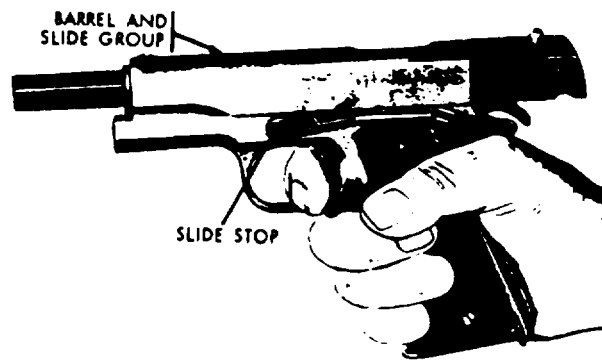

STEP 4. SLIDE GROUP LOCKED IN OPEN POSITION AFTER LAST CARTRIDGE IS FIRED.

WE 17394

Figure 4-1. Hand Junction test for Caliber .45, Automatic Pistol, M911A1.

APPENDIX A

REFERENCES

A-1. Publication Indexes

The following indexes should be consulted frequently for the latest changes or revisions of references given in this appendix and for new publications relating to material covered in this manual.

Military Publications:

Index of Administrative Publications.....	DA Pam 310-1
Index of Army Films, Transparencies, GTA Charts and Recording.....	DA Pam 108-1
Index of Blank Forms	DA Pam 310-2
Index of Doctrinal Training, and Organizational Publications.....	DA Pam 310-3
Index of Modification Work Orders.....	DA Pam 310-7
Index of Supply Catalogs and Supply Manuals (excluding types 7, 8 and 9).....	DA Pam 310-8
Index of Technical Manuals, Technical Bulletins, Supply Manuals (types 7, 8 and 9) Supply Bulletins, and Lubrication Orders.....	DA Pam 310-4

A-2. Supply Catalogs

Sets, Kits, and Outfits Components List, Tool Set, Direct and General Support Maintenance, Basic Small Arms.....	SC 4933-95-CL-E04
--	-------------------

A-3. Forms

The following form pertains to this materiel.
DA Form 2028, Recommended Changes to DA Publications.

A-4. Other Publications

The following explanatory publications pertain to this materiel.
a. General.

Operator and Organizational Maintenance Manual including Repair Parts and Special Tool Lists for Caliber .45 Automatic Pistol M1911A1 with Hip Holster and Caliber .45 Automatic Pistol M1911A1 with Shoulder Holster.....	TM 9-1005-211-12
Pistols and Revolvers	FM 23-35
Army Equipment Record Procedures.....	TM 38-750
<i>b. Cleaning.</i> Cleaning of Ordnance Materiel.....	TM 9-208-1

c. Inspections.
 Command Maintenance Management Inspection AR 750-8
 Small Arms Weapons: Standards for Visual
 Inspections of Barrels TBORD 437

d. Issue of Supplies and Equipment.
 Requisitioning, Receipt, and Issue System..... AR 725-50

e. Logistics.
 Malfunctions Involving Ammunition and Explosives..... AR 700-1300-8

f. Maintenance of Supplies and Equipment.
 Organization, Policies, and Responsibilities for
 Maintenance OperationsAR76M

g. Safety.
 Accident Reporting and Records.....AR385-40

APPENDIX B

DIRECT SUPPORT, GENERAL SUPPORT, AND DEPOT MAINTENANCE REPAIR PARTS AND SPECIAL TOOLS LIST

Section I. INTRODUCTION

B-1. Scope

This appendix is a list of repair parts and special tools required for the performance of direct support, general support, and depot maintenance of the M1911AI, Caliber .45, Automatic, Pistol.

B-2. General

This repair parts and special tools list is divided into the following sections:

a. *Repair Parts-Section II.* A list of repair parts authorized for the performance of maintenance at the direct support, general support and depot level in figure and item number sequence.

b. *Special Tools, Test and Support Equipment-Section III.* A list of special tools, test and support equipment authorized for the performance of maintenance at the direct support, general support, and depot level.

c. *Federal Stock Number and Reference Number Index-Section IV.* A list of Federal stock numbers in ascending numerical sequence followed by a list of referenced numbers in ascending alpha-numeric sequence, cross-referenced to the illustration figure number and item number.

B-3. Explanation of Columns

The following provides an explanation of columns in the tabular lists in sections II and III:

a. *Source, Maintenance, and Recoverability Codes (SMR), Column 1.*

(1) Source code, indicates the selection

status and source for the listed item. Source codes used are:

<i>Code</i>	<i>Explanation</i>
P	Repair parts which are stocked in or supplied from the GSA, DSA, or Army supply system, and authorized for use at indicated maintenance categories
M	Repair parts which are not procured or stocked but are manufactured at indicated maintenance categories
A	Assemblies which are not procured or stocked as such but are made up of two or more units. each of which carry individual FSNs and descriptions and are procured and stocked and can be assembled by units at indicated maintenance categories.
X	Parts and assemblies which are not procured or stock at the mortality of which is normally below that of the applicable end item: and the failure of which should result in retirement of the end item from the supply system.
X1	Repair parts which are not procured or stocked. the requirements for which will be supplied by use of next higher assembly or component.
X2	Repair parts which are not stocked. The indicated maintenance category requiring such repair parts will attempt to obtain through cannibalization: if not obtainable through cannibalization, such repair parts will be requisitioned with supporting justification through normal channels.
C	Repair parts authorized for local procurement. When not obtainable from local procurement such repair parts will be requisitioned through normal supply channels with a supporting statement of non-availability from local procurement
G	Major assemblies that are procured with PEMA funds for initial issue only to be used as exchange assemblies at DSU and GSU level. These assemblies will not be stocked above DSU and GSU level or returned to Depot supply level.

(2) Maintenance code, indicates the lowest category of maintenance authorized to install the listed item. The maintenance level codes are:

Code	Explanation
C	Operator/crew
O	Organizational Maintenance
F	Direct Support Maintenance
H	General Support Maintenance
D	Depot Maintenance

(3) Recoverability code, indicates whether unserviceable items should be returned for recovery or salvage. Items not coded are expendable. Recoverability codes are:

Code	Explanation
R	Repair parts and assemblies which are economically repairable at DSU and GSU activities and are normally furnished by supply on an exchange basis.
T	High dollar value recoverable repair parts which are subject to special handling and are issued on an exchange basis. Such repair parts are normally repaired or overhauled at depot maintenance activities.
U	Repair parts specifically selected for salvage by reclamation units because of precious metal content critical materials, high dollar value. reusable casings, etc.
S	Repair parts and assemblies which are economically repairable at DSU and GSU activities and normally are furnished by supply on an exchange basis. However, when these items are determined to be uneconomically repairable by a GSU, they will be evacuated to a depot for evaluation and analysis before final disposition.

No Code

Indicated Parts will be considered expendable.

b. *Federal Stock Number, Column 2.* This column indicates the Federal stock number assigned to the item and will be used for requisitioning purposes.

c. *Description, Column 9.* This column indicates the Federal item name and any additional description of the item required. The abbreviation "w/e" when used as a part of the nomenclature, indicates the Federal stock number includes all armament equipment, accessories, and repair parts issued with the item. A part number or other reference number is followed by the applicable five-digit Federal supply code for manufacturers in parentheses. Repair parts quantities included in the kits, sets, and assemblies are shown in front of the repair part name.

d. *Unit of Measure (U/M), Column 4.* A 2 character alphabetic abbreviation indicating the amount or quantity of the item upon which the allowances are based, e.g., ft, ea, pr, etc.

e. *Quantity Incorporated in Unit, Column 5.* This column indicates the quantity of the item used in a functional group or assembly. A "V" appearing in this column in lieu of a quantity indicates that a definite quantity cannot be indicated (e.g., shims, spacers, etc.).

f. *30-Day DS/GS Maintenance Allowance, Columns 6, and 7.*

Note. Allowances in GS column are for GS maintenance only.

(1) The allowance columns are divided into three subcolumns. Indicated in each sub-column, opposite the first appearance of each item, is the total quantity of items authorized for the number of equipment supported. Subsequent appearances of the same item will have the letters "REF" in the applicable allowance columns. Items authorized for use as required but not for initial stockage are identified with an asterisk in the allowance column.

(2) The quantitative allowances for DS/GS levels of maintenance will represent initial stockage for a 30-day period for the number of equipments supported,

(3) Determination of the total quantity of parts required for maintenance of more than 100 of these equipments can be accomplished by converting the equipment quantity to a decimal factor by placing a decimal point before the next to last digit of the number to indicate hundredths, and multiplying the decimal factor by the parts quantity authorized in the 51-100 allowance column. Example, authorized allowance for 51-100 equipment is 40; for 150 equipments multiply 40 by 1.60 or 60 parts required.

g. *1-year Allowances Per 100 Equipments/Contingency Planning Purposes, Column 8.* This column indicates opposite the first appearance of each item the total quantity required for distribution and contingency planning purposes. The range of items indicates total quantities of all authorized items required to provide for adequate support of 100 equipments for one year.

h. Depot Maintenance Allowance Per 100 Equipment, Column 9. This column indicates opposite the first appearance of each item, the total quantity authorized for depot maintenance of 100 equipments. Subsequent appearances of the same item will have the letters "REF" in the allowance column. Items authorized for use as required but not for initial stockage are identified with an asterisk in the allowance column.

i. Illustration, Column 10. This column is divided as follows:

(1) *Figure Number, Column 10a.* Indicates the figure number of the illustration in which the item is shown.

(2) *Item Number, Column 10b.* Indicates the callout number used to reference the item in the illustration.

B-4. Special Information

a. Identification of the usable on codes included in column 3 of this publication are:

<i>Code</i>	<i>Used On</i>
	Parts without any code are used on either the Pistol. Caliber .46, Automatic. M1911A1 with Hip Holster or Pistol, Caliber .46, Automatic, M1911A1 with Shoulder Holster.
A	Pistol. Caliber .45, Automatic, M1911A1 with hip holster only.
B	Pistol, Caliber .45, Automatic. M1911A1 with shoulder holster only.

b. The following publications pertain to the Pistol, Caliber .46, Automatic, M91 1A1 and its components.

FM 23-35	Pistols and Revolvers
TM 9-1005-211-12	Operator's and Organizational Maintenance Manual including Basic Issue Items List Repair Parts and Special Tools and Equipment Lists.

B-5. How to Locate Repair Parts

a. When Federal stock number or reference number is unknown:

(1) *First.* Using the table of contents, determine the functional group or assembly within which the repair part belongs. This is

necessary since illustrations are prepared for functional groups or assemblies and listings are divided into the same groups.

(2) *Second.* Find the illustration covering the functional group or assembly to which the repair part belongs.

(3) *Third.* Identify the repair part on the illustration and note the illustration figure and item number of the repair part.

(4) *Fourth.* Using the Repair Parts Listing, find the functional group or assembly to which the repair part belongs and locate the illustration figure and item number noted on the illustration.

b. When Federal stock number or reference number is known:

(1) *First.* Using the Index of Federal Stock Numbers and Reference Numbers find the pertinent Federal stock number or reference number. This index is in ascending FSN sequence followed by a list of reference numbers in ascending alpha-numeric sequence, cross-referenced to the illustration figure number and item number.

(2) *Second.* Using the Repair Parts Listing, find the functional group or assembly of the repair part and the illustration figure number and item number referenced in the Index of Federal Stock Numbers and Reference numbers.

B-6. Abbreviations

<i>Abbreviations</i>	<i>Explanation</i>
cd-pltd	cadmium plated
chain	chamfer
fil-hd	fillister head
fl-ck-hd	flat countersunk head
fl-fil-hd	flat fillister head
o/a	over-all
phos-fin	phosphate finish
s	steel

B-7. Federal Supply Codes for Manufacturers

<i>Code</i>	<i>Manufacturer</i>
19204	Rock Island Arsenal Rock Island. Illinois
19205	Springfield Armory Springfield. Mass.
96906	Military Standard

Section II. REPAIR PARTS

(1) Source Maint. And Reciv. Code			(2) Federal Stock No.	(3) Description	(4) Unit of Issue	(5) Qty Inc. in Unit	(6) Direct Support 30-Day Maint. Allowance			(7) General Support 30-Day Maint. Allowance			(8) 1 Yr. Alw. Per 100 Equip/ Cntgey Planning	(9) Depot Maint. Alw. Per 100 Equip	(10) Illustration	
(A) Source	(B) Maint.	(C) Recov					(A) 1-20	(B) 21-50	(C) 51-100	(A) 1-20	(B) 21-50	(C) 51-100			(A) Fig. No.	(B) Item No.
P	C		1005-550-8697	REPAIR PARTS FOR: PISTOL, CAL. .45, AUTOMATIC, M1911A1 MAJOR GROUP AND ASSEMBLIES	EA	1	2	2	2	2	2	2	24	48	B1	1
P	F		1005-600-8595	MAGAZINE, CARTRIDGE: 5508694 (19205)	EA	1	*	*	2	*	*	2	24	4	B1	2
A			-----	STOP, SLIDE: 6008595 (19205)	---	1	-	-	-	-	-	-	-	-	B1	3
A			-----	SLIDE GROUP	---	1	-	-	-	-	-	-	-	-	B1	4
P	F		1005-507-3201	RECEIVER GROUP	EA	1	*	2	2	*	2	2	24	8	B2	1
P	F		1005-501-3200	SLIDE GROUP PLUG, RECOIL SPRING: 5013201 (19205)	EA	1	*	2	2	*	2	2	24	8	B2	2
P	F		1005-501-3200	SPRING, HELICAL, COMPRESSION: 30 COILS, RECOIL 5013200 (19205)	EA	1	*	2	2	*	2	2	24	8	B2	2
P	F		1005-600-8597	GUIDE, RECOIL SPRING: 6008597 (19205)	EA	1	*	*	2	*	*	2	24	4	B2	3
P	F		1005-600-8596	BEARING, BARREL: 6008596 (19205)	EA	1	*	*	2	*	*	2	24	4	B2	4
P	F		1005-722-3849	BARREL, PISTOL: 7791193 (19205)	EA	1	*	2	2	*	2	2	24	20	B2	5
P	O		5315-501-3199	PIN, STRAIGHT, HEADLESS: S, 0.1555 MAX DIS, 0.358 O/A LG (BARREL LINK) 5013199 (19205)	EA	1	2	2	2	2	2	2	24	15	B2	6
P	O		1005-507-3198	LINK, BARREL: 5013198 (19205)	EA	1	2	2	2	2	2	2	24	5	B2	7
P	F		1005-501-3205	STOP, FIRING PIN: 5013205 (19205)	EA	1	*	*	2	*	*	2	24	10	B2	8
P	O		1005-600-8599	PIN, FIRING: 6008599 (19205)	EA	1	*	*	2	*	2	2	24	5	B2	9
P	O		1005-501-3204	SPRING, HELICAL, COMPRESSION: 40 COILS FIRING PIN 5013204 (19205)	EA	1	*	2	2	*	2	2	24	8	B2	10
P	F		1005-600-8598	EXTRACTOR, SMALL ARMS CARTRIDGE: 6008598 (19205)	EA	1	*	2	2	*	2	2	24	8	B2	11
P	H	R	1005-876-4033	SLIDE, AUTOMATIC PISTOL 7790353 (19205)	EA	1	-	-	-	*	*	2	24	4	B2	12

P	F	1005-501-3196	SIGHT, REAR: S, 0.245 H, 0.626 LG 5013196 (19205)	EA	1	*	*	2	*	*	2	24	4	B2	13
P	F	1005-501-3197	SIGHT, FRONT 5013197 (19205)	EA	1	*	*	2	*	*	2	24	8	B2	14
XI		-----	SLIDE: 7790314	-	1	-	-	-	-	-	-	-	-	B2	15
P	F	1005-550-3840	RECEIVER GROUP SAFETY, SMALL ARMS: 5508840 (19205)	EA	1	*	*	2	*	*	2	24	8	B3	1
P	F	1005-501-3212	PIN, MAINSPRING HOUSING: 5013212 (19205)	EA	1	*	*	2	*	*	2	24	4	B3	2
P	F	1005-650-1828	SAFETY, GUN GRIP: 6501828 (19205)	EA	1	*	*	2	*	*	2	24	4	B3	3
P	D	1005-556-4058	HOUSING, ASSEMBLY, MAINSPRING: 5564058 (19205)	EA	1	-	-	-	-	-	-	-	5	B3	4
P	F	5315-844-4790	PIN, SPRING: TUBULAR, SLOTTED, BOTH ENDS CHAM, S, CD-PLTD, 0.093 DIA, 0.500 LG, 0.022 STK THK MS 16562-25 (96906)	EA	1	*	*	2	*	*	2	24	2	B3	5
P	F	1005-501-3214	LOOP, LANYARD: U SHAPE, 0.107 STK DIA, ½ LG 5013214 (19205)	EA	1	*	*	2	*	*	2	24	2	B3	6
XI		-----	HOUSING, MAINSPRING: 5503841	-	-	-	-	-	-	-	-	-	-	B3	7
P	F	5315-501-3210	PIN, STRAIGHT, HEADED: FL-CK-HD, S, 0.084 SHANK DIA, 0.369 LG (MAIN- SPRING HOUSING) 5013210 (19205)	EA	1	*	*	2	*	*	2	24	4	B3	8
P	F	5315-501-3209	PIN, STRAIGHT, HEADED: FL-FIL-HD, S, 0.174 SHANK DIA, 0.608 LG (MAIN- SPRING HOUSING) 5013209 (19205)	EA	1	*	*	2	*	*	2	24	4	B3	9
P	F	1005-501-3208	SPRING, HELICAL, COMPRESSION: S, 21.5 COILS, HOUSING ASSY 5013208 (19205)	EA	1	*	2	2	*	2	2	24	5	B3	10
P	F	1005-501-3213	PLUNGER, DETENT: 5013208 (19205)	EA	1	*	*	2	*	*	2	24	4	B3	11
P	O	1005-600-8602	SPRING, SEAR: 6008602 (19205)	EA	1	*	2	2	*	2	2	24	12	B3	12
P	F	5315-501-3206	PIN, STRAIGHT, HEADED: FL-CK-HD, S, 0.157 MAX SHANK DIA, 0.786 LG UNDER HD (HAMMER) 5013206 (19205)	EA	1	*	*	2	*	*	2	24	5	B3	13
P	F	1005-980-1743	HAMMER, FIRING, SMALL ARMS: 7790803 (19205)	EA	1	*	*	2	*	*	2	24	4	B3	14

Section II. REPAIR PARTS - Continued

(1) Source Maint. And Reciv. Code			(2) Federal Stock No.	(3) Description	(4) Unit of Issue	(5) Qty Inc. in Unit	(6) Direct Support 30-Day Maint. Allowance			(7) General Support 30-Day Maint. Allowance			(8) 1 Yr. Alw. Per 100 Equip/ Cntgey Planning	(9) Depot Maint. Alw. Per 100 Equip	(10) Illustration	
(A) Source	(B) Maint.	(C) Recov					(A) 1-20	(B) 21-50	(C) 51-100	(A) 1-20	(B) 21-50	(C) 51-100			(A) Fig. No.	(B) Item No.
P	F		5315-501-3207	PIN, STRAIGHT, HEADLESS: S, PHOS-FIN., 0.96 MAX DIA, 0.305 O/A LG (HAMMER STRUT) 5013207 (19205)	EA	1	*	2	2	*	2	2	24	5	B3	15
P	O		1005-600-8600	STRUT, HAMMER 6008600 (19205)	EA	1	*	*	2	*	2	2	24	4	B3	16
P	F		5315-501-3211	PIN, STRAIGHT, HEADED: FL-CK-HD, S, 0.110 MAX SHFT DIA, 0.780 MAX LG UNDER HD (SEAR) 5013211 (19205)	EA	1	*	*	2	*	*	2	24	4	B3	17
P	F		1005-592-9974	SEAR: 7268068 (19205)	EA	1	*	2	2	*	2	2	24	16	B3	18
P	F		1005-600-8603	DISCONNECTOR, RECEIVER ASSEMBLY: 6008603 (19205)	EA	1	*	2	2	*	2	2	24	16	B3	19
P	F		1005-600-8609	CATCH, MAGAZINE: 6008609 (19205)	EA	1	*	*	2	*	*	2	24	4	B3	20
P	F		1005-501-3218	LOCK, MAGAZINE CATCH: 5013218 (19205)	EA	1	*	*	2	*	*	2	24	8	B3	21
P	F		1005-501-3217	SPRING, HELICAL, COMPRESSION : 13 COILS MAGAZINE CATCH 5013217 (19205)	EA	1	*	*	2	*	*	2	24	10	B3	22
P	F		1005-614-7780	TRIGGER: 6147780 (19205)	EA	1	*	*	2	*	*	2	24	4	B3	23
P	F		5315-501-3203	PIN, STRAIGHT, HEADLESS: S, 0.063 MAX DIZ, 39/64 O/A LG (EJECTOR) 5013203 (19205)	EA	1	*	*	2	*	*	2	24	4	B3	24
P	F		1005-903-8192	EJECTOR, CARTRIDGE; 11010485 (19205)	EA	1	*	*	2	*	*	2	24	4	B3	25
P	O		5305-601-9023	SCREW, MACHINE: FIL-HD, S, PHOS-CTD, 0.150-5 ONS, 0.260 O/A LG (GRIP) 6019023 (19205)	EA	4	2	2	2	2	2	2	24	16	B3	26
P	O		1005-556-4063	GRIP, PISTOL: LH, PLASTIC, CHECKERED 5564063 (19205)	EA	1	*	2	2	*	2	2	24	10	B3	27
P	O		1005-556-4062	GRIP, PISTOL: RH, PLASTIC CHECKERED 5564062 (19205)	EA	1	*	2	2	*	2	2	24	10	B3	28

P	F	1005-6019022	BUSHING, STOCK SCREW: RECEIVER ASSY 6019022 (19205)	EA	4	*	*	2	*	*	2	24	8	B3	29
P	F	1005-501-3195	PLUNGER, SAFETY: 5013195 (19205)	EA	1	*	*	2	*	*	2	24	4	B3	30
P	O	1005-501-3194	SPRING, HELICAL, COMPRESSION: 14-1/2 COILS, PLUNGER 5013194 (19205)	EA	1	*	*	2	*	2	2	24	8	B3	31
P	F	1005-501-3193	PLUNGER SLIDE STOP: 5013194 (19205)	EA	1	*	*	2	*	*	2	24	4	B3	32
P	F	1005-600-3594	TUBE, PLUNGER: 6006594 (19205)	EA	1	*	2	2	*	2	2	24	8	B3	33
X1		-----	RECEIVER: 5535359	----	1	---	---	---	---	---	---	---	---	B3	34

Section III. SPECIAL TOOLS, TEST AND SUPPORT EQUIPMENT

(1) Source Maint. And Recov. Code			(2) Federal Stock No.	(3) Description	(4) Unit of Issue	(5) Qty. Inc. in Unit	(6) Direct Support 30-Day Maint. Allowance			(7) General Support 30-Day Maint. Allowance			(8) 1-yr Alw Per 100 Equip Cntgcy	(9) Depot Maint. Alw Per 100 Equip	(10) Illustration	
(A) Source	(B) Maint.	(C) Recov.					(A) 1-20	(B) 21-50	(C) 51-100	(A) 1-20	(B) 21-50	(C) 51-100			(A) Fig. No.	(B) Item No.
TOOLS AND EQUIPMENT AUTHORIZED FOR UNIT REPLACEMENT																
			1005-288-3565	SWAB, SMALL ARMS CLEANING: COTTON, 2-1/2 SQ (1000 IN PKG) 6019316 (19204)	PK	--	2	2	2	2	2	2	24			
			1005-560-4036	BRUSH, CLEANING, SMALL ARMS: M5 BORE 5504036 (19205)	EA	--	2	2	2	2	2	2	24			
			1006 556-4102	ROD, CLEANING, SMALL ARMS: M4 5564102 (19205)	EA	--	2	2	2	2	2	2	24			
			1095-592-6491	HOLSTER, PISTOL: HIP, M1916 (BLACK) 779146 (19205)	EA	--	*	2	*	3	3	2	24			
				OR												
			1095-975-2353	HOLSTER, PISTOL: SHOULDER, M7, (BLACK) 7791627 (1920)	EA	--	*	2	2	*	2	2	24			
				TOOLS AND EQUIPMENT THE FOLLOWING ITEMS ARE REQUISITIONED AND ISSUED, IF NOT OTHERWISE AUTHORIZED, TO ORDNANCE MAINTENANCE UNITS PERFORMING MAINTENANCE SUPPORT OF THE MAJOR ITEMS. ITEMS MAY BE REQUISITIONED AS REQUIRED FOR REPLACEMENT UNDER THEIR INDIVIDUAL STOCK NUMBERS. THE 15- DAY LEVEL IS NOT APPLICABLE.												
				THE FOLLOWING BASIC SMALL ARMS DIRECT AND GENERAL SUPPORT MAINTENANCE TOOL SET IS AUTHORIZED, AS REQUIRED, TO ALL MAINTENANCE SUPPORT UNITS WITH A SMALL ARMS REPAIR MISSION.												
R			4933-775-0356	TOOL SET, DIRECT AND GENERAL SUPPORT MAINTENANCE, BASIC	SE	--	*	*	*	*	*	*				

R	4933-725-5340	SMALL ARMS: 8426358 (19205) NOTE: SEE SC 4933-95-CL-E04 FOR COMPONENTS TOOL KIT, PISTOL, AUTOMATIC, CALIBER .45: DEPOT MAINTENANCE 7265840 (19205)	SE	--	---	---	---	---	---	---	---	*		
	4935-731-9912	COMPOSED OF: 2 - GAGE, SNAP, FIXED: NOT GO 0.150, 1-1/4 W, 3/32 THK, 2 LG. 7319912 (19205)	EA	--	---	---	---	---	---	---	---	---	B4	1
	4933-731-9913	2 - GAGE, SNAP, FIXED: NOT GO 0.197, 1-1/4 W, 3/32 THK, 2 LG. 7319913 (19205)	EA	--	---	---	---	---	---	---	---	---	B4	2
	4933-731-9915	2 - GAGE, PLUG, BARREL BUSHING: NOT GO, 0.582 AND 0587 DIA. 7319915 (19205)	EA	--	---	---	---	---	---	---	---	---	B4	3
	5220-731-9916	2 - GAGE, PLUG, PLAIN CYLINDRICAL: SINGLE END, NOT GO 0.704 OD 7319916 (19205) SPECIAL PACKAGING MATERIAL THE VOLATILE CORROSION INHIBITOR LISTED BELOW IS REQUIRED WHEN THE MAJOR ITEM IS PACKAGED FOR STORAGE PURPOSES. FLIED REQUIREMENTS FOR PACKAGING THE MAJOR ITEMS ARE REQUISITIONED AS REQUIRED.												
	1005-336-0226	BAG, BARRIER, VCI TREATED LINER: 7255932	EA	--	---	---	---	---	---	---	---	---	100	

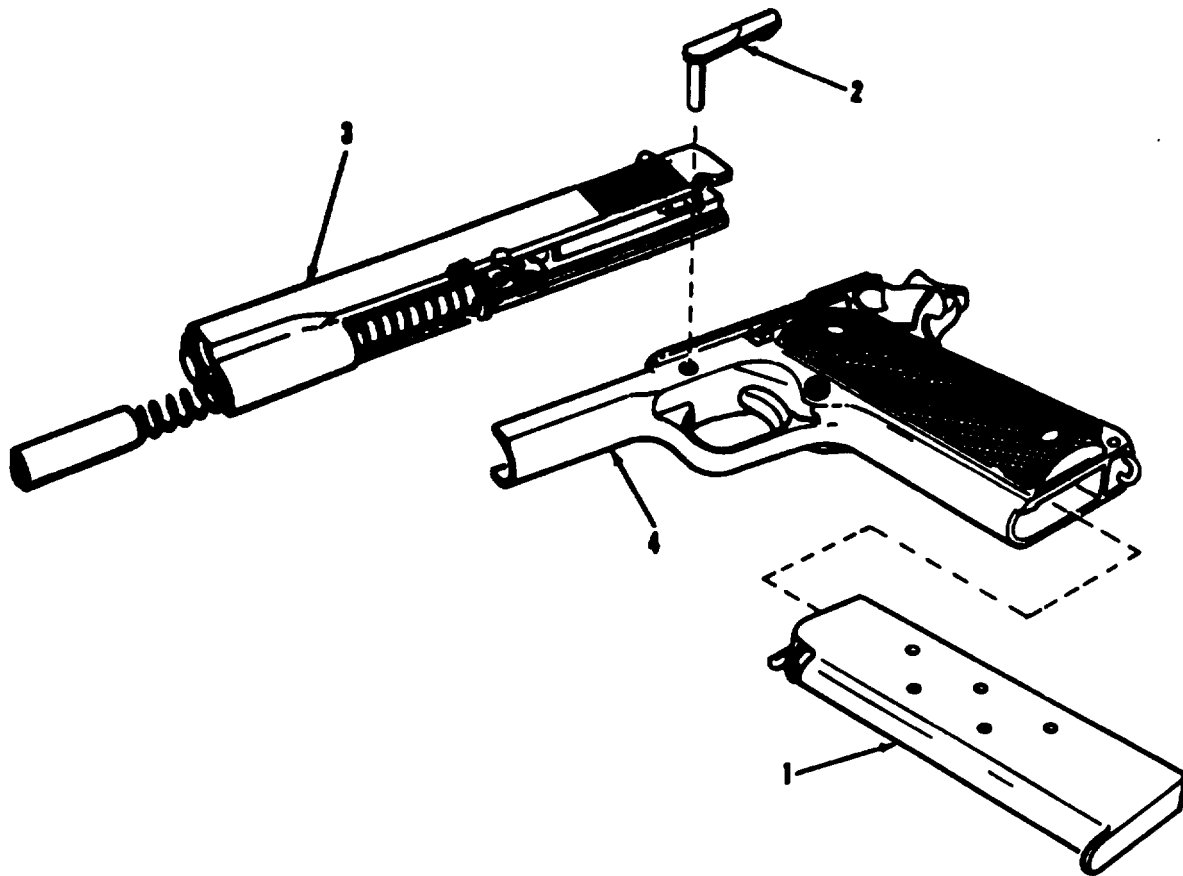

Figure B-1. Major groups and assemblies-partial exploded view.

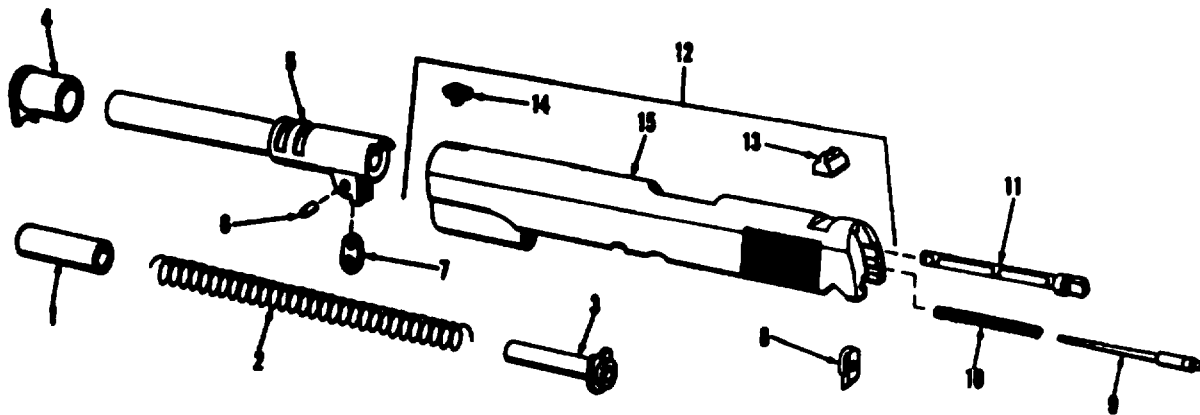

Figure B-2. Slide group-exploded view.

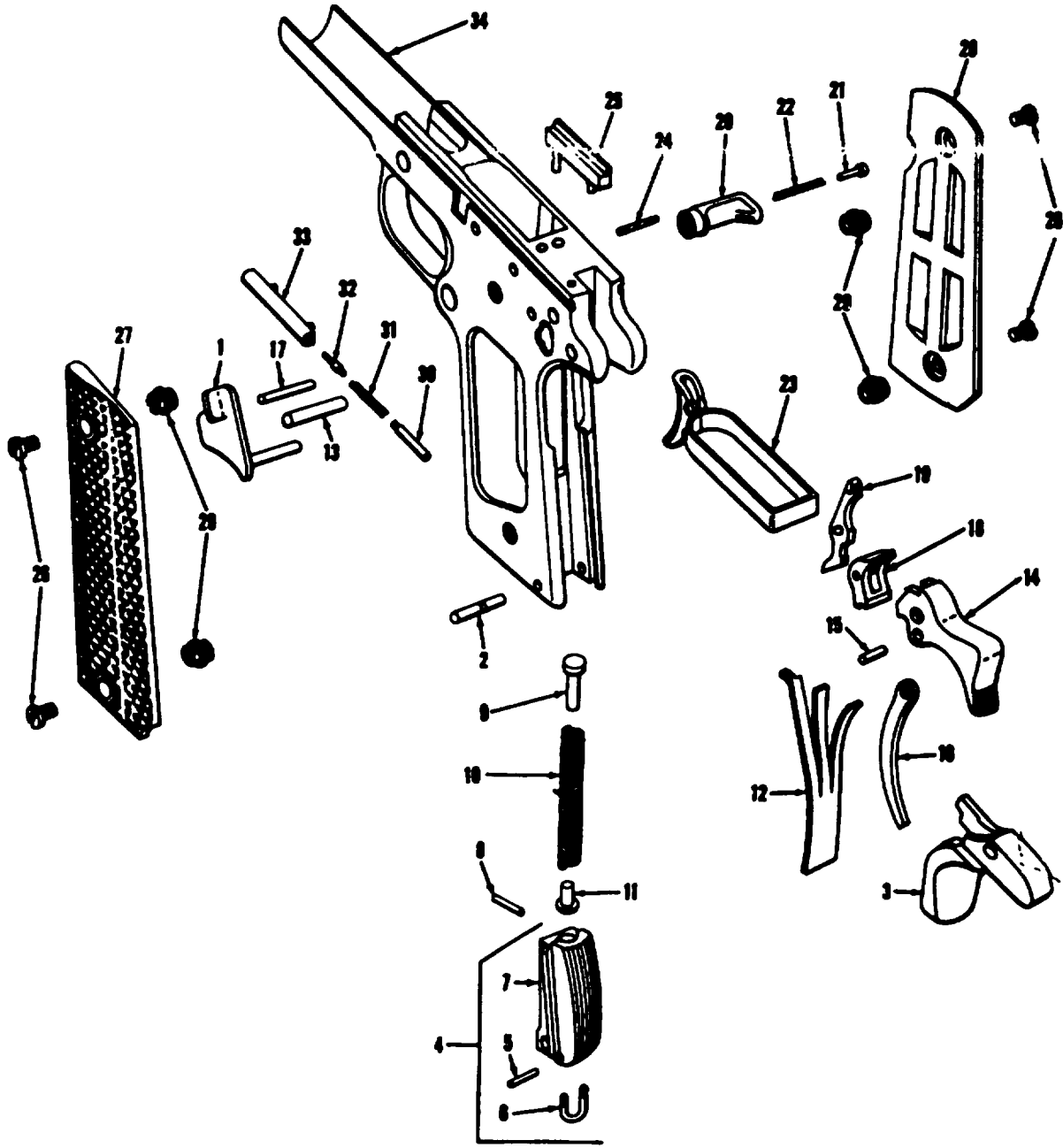
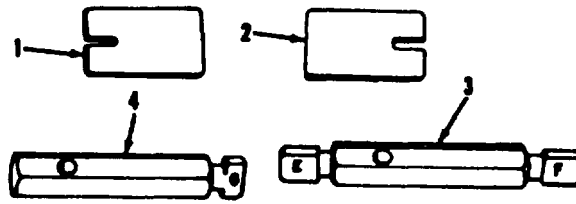

Figure B-3. Receiver group-exploded view.

WE 17400

B-11



WE 8851

Figure B-4. Tools and equipment.

**Section IV. INDEX-FEDERAL STOCK NUMBER AND REFERENCE NUMBER
CROSS-REFERENCE TO FIGURE AND ITEM NUMBER**

<i>Stock Number</i>	<i>Figure No.</i>	<i>Item No.</i>	<i>Stock Number</i>	<i>Figure No.</i>	<i>Item No.</i>
1005-501-3193I	B-3	33	1005-500-3598	B-2	11
1005-501-3194	B-3	31	1005-600-3599	B-2	9
1005-501-3195	B-3	30	1005-600-3600	B-3	16
1005-501-3196	B-3	13	1005-600-8602	B-3	12
1005-501-3197	B-2	14	1005-600-8603	B-3	19
1005-501-3198	B-2	7	1005-600-8609	B-3	20
1005-501-3200	B-2	2	1005-601-9022	B-3	29
1005-501-3201	B-2	1	1005-614-7780	B-3	23
1005-501-3204	B-2	10	1005-650-1828	B-3	3
1005-501-3205	B-2	8	1005-722-3849	B-2	5
1005-501-3206	B-3	10	1005-876-4033	B-2	12
1005-501-3212	B-3	2	1005-903-8192	B-3	25
1005-501-3213	B-3	11	1005-908-1743	B-3	14
1005-501-3214	B-3	6	4933-731-9912	B-4	1
1005-501-3217	B-3	22	4933-731-9912	B-4	2
1005-501-3218	B-3	21	4933-731-9915	B-4	3
1005-550-3340	B-3	1	5220-731-9916	B-4	4
1005-550-8694	B-1	1	5305-601-9023	B-3	26
1005-556-4058	B-3	4	5315-501-3199	B-2	6
1005-556-4062	B-3	28	5315-501-3203	B-3	24
1005-556-4063	B-3	27	5315-501-3206	B-3	13
1005-592-9974	B-3	18	5315-501-3207	B-3	15
1005-600-8594	B-3	33	5315-501-3209	B-3	9
1005-600-8595	B-1	2	5315-501-3210	B-3	8
1005-600-8596	B-2	4	5315-501-3211	B-3	17
1005-600-8597	B-2	3	5315-844-4790	B-3	5

<i>Reference Number</i>	<i>Mfr Code</i>	<i>Fig. Number</i>	<i>Item Number</i>	<i>Reference Number</i>	<i>Mfr Code</i>	<i>Fig. Number</i>	<i>Item. Number</i>
MS 16562-25	96906	B-3	5	5013207	19205	B-3	15
5013193	19205	B-3	32	5013208	19205	B-3	10
5013194	19205	B-3	31	5013209	19205	B-3	9
5013195	19205	B-3	30	5013210	19205	B-3	8
5013196	19205	B-2	13	5013211	19205	B-3	17
5013197	19205	B-2	14	5013212	19205	B-3	2
5013198	19205	B-2	7	5013213	19205	B-3	11
5013199	19205	B-2	6	5013214	19205	B-3	6
5013200	19205	B-2	2	5013217	19205	B-3	22
5013201	19205	B-2	1	5013218	19205	B-3	21
5013203	19205	B-3	24	5503840	19205	B-3	1
5013204	19204	B-2	10	5503841		B-3	7
5013205	19205	B-2	8	5508694	19205	B-1	1
5013206	19205	B-3	13	5564058	19205	B-3	4

<i>Reference Number</i>	<i>Mfr Code</i>	<i>Fig. Number</i>	<i>Item Number</i>	<i>Reference Number</i>	<i>Mfr Code</i>	<i>Fig. Number</i>	<i>Item. Number</i>
5564062	19205	B-3	28	6147780	19205	B-3	22
5564063	19205	B-3	27	5501828	19205	B-3	2
6008594	19205	B-3	33	6535359		B-3	34
6008595	19205	B-1	2	7268068	19205	B-3	18
6008596	19205	B-2	4	7319912	19205	B-4	1
6008597	19205	B-2	3	7319913	19205	B-4	3
6008598	19205	B-2	11	7319915	19205	B-4	3
6008599	19205	B-2	9	7319916	19205	B-4	4
6008600	19205	B-3	16	7790314		B-2	15
6008602	19205	B-3	12	7790353	19205	B-2	12
6008603	19205	B-3	19	7790803	19205	B-3	14
6008609	19205	B-3	20	7791193	19205	B-2	5
6019022	19205	B-3	29	11010435	19205	B-3	25
6019023	19205	B-3	26				

B-13

By Order of the Secretary of the Army:

Official:

PAUL T. SMITH
Major General, United States Army
The Adjutant General

FRED C. WEYAND
General, United States Army
Chief of Staff

DISTRIBUTION:

To be distributed in accordance with DA Form 12-40, (qty rqr block no. 117) Direct and (General Support maintenance requirements for Pistol, Cal .45, Automatic M1911A1.

*U. S. GOVERNMENT PRINTING OFFICE : 0 - 311-831 (44857)

RECOMMENDED CHANGES TO EQUIPMENT TECHNICAL PUBLICATIONS



THEN... JOT DOWN THE DOPE ABOUT IT ON THIS FORM, CAREFULLY TEAR IT OUT, FOLD IT AND DROP IT IN THE MAIL!

SOMETHING WRONG WITH THIS PUBLICATION?

FROM: (PRINT YOUR UNIT'S COMPLETE ADDRESS)

DATE SENT

PUBLICATION NUMBER

PUBLICATION DATE

PUBLICATION TITLE

BE EXACT... PIN-POINT WHERE IT IS

PAGE NO.

PARA-GRAPH

FIGURE NO.

TABLE NO.

IN THIS SPACE TELL WHAT IS WRONG AND WHAT SHOULD BE DONE ABOUT IT:

TEAR ALONG PERFORATED LINE

PRINTED NAME, GRADE OR TITLE, AND TELEPHONE NUMBER

SIGN HERE:

DA FORM 2028-2
1 JUL 79

PREVIOUS EDITIONS ARE OBSOLETE.

P.S.—IF YOUR OUTFIT WANTS TO KNOW ABOUT YOUR RECOMMENDATION MAKE A CARBON COPY OF THIS AND GIVE IT TO YOUR HEADQUARTERS.

PIN: 026369-000

This fine document...

Was brought to you by me:



[Liberated Manuals -- free army and government manuals](#)

Why do I do it? I am tired of sleazy CD-ROM sellers, who take publicly available information, slap “watermarks” and other junk on it, and sell it. Those masters of search engine manipulation make sure that their sites that sell free information, come up first in search engines. They did not create it... They did not even scan it... Why should they get your money? Why are not letting you give those free manuals to your friends?

I am setting this document FREE. This document was made by the US Government and is NOT protected by Copyright. Feel free to share, republish, sell and so on.

I am not asking you for donations, fees or handouts. If you can, please provide a link to liberatedmanuals.com, so that free manuals come up first in search engines:

<A HREF=<http://www.liberatedmanuals.com/>>Free Military and Government Manuals

- Sincerely
Igor Chudov
<http://igor.chudov.com/>
- [Chicago Machinery Movers](#)