



**DEPARTMENT OF THE NAVY (DON)
FALL-PROTECTION GUIDE
FOR
SHORE FACILITIES**

August, 2013

TABLE OF CONTENTS

<u>SECTION #</u>		<u>PAGE #</u>
	TABLE OF CONTENTS -----	2
1.0	INTRODUCTION -----	7
1.1	PURPOSE -----	7
1.2	BACKGROUND -----	7
1.3	APPLICATION -----	7
1.4	SCOPE -----	8
1.5	NAVY/MARINE CORPS FALL PROTECTION POLICY -----	8
1.6	ACTIVITY FALL PROTECTION POLICY -----	9
1.7	BASIC PROGRAM REQUIREMENTS -----	9
1.8	COMPLIANCE -----	10
1.9	COMPARISON BETWEEN OSHA STANDARDS, NAVY AND USACE EM 385 FP REQUIREMENTS---	11
1.10	REGULATIONS/STANDARDS -----	11
2.0	DEFINITIONS -----	13
3.0	FALL PROTECTION PROGRAM -----	24
3.1	COMPONENTS OF A FALL PROTECTION PROGRAM -----	24
3.2	SAMPLE WRITTEN FP PROGRAM -----	25
3.3	FP PROGRAM COMPLIANCE AUDIT CHECKLIST--	30
3.4	STEP BY STEP HOW TO ESTABLISH, MANAGE AND IMPLEMENT A FP PROGRAM -----	37
4.0	DUTIES AND RESPONSIBILITIES -----	38
4.1	QUALIFIED PERSON FOR FP-----	38
4.2	COMPETENT PERSON FOR FP-----	38
4.3	FP PROGRAM MANAGER/ADMINISTRATOR-----	39
5.0	WORKPLACE SURVEYS AND ASSESSMENT OF -- FALL HAZARDS	40
5.1	FALL HAZARD SURVEY -----	40
5.2	FALL HAZARD ASSESSMENT -----	41
5.3	REQUIREMENTS FOR FALL HAZARD SURVEY REPORT-----	41
5.4	SAMPLE FALL HAZARD SURVEY REPORT -----	43
5.5	SITE SPECIFIC FALL HAZED SURVEY CHECKLIST-	46
6.0	TRAINING -----	47
6.1	TRAINING REQUIREMENTS -----	47
6.2	TRAINING MATRIX -----	49

August, 2013

6.3	REFRESHER/UPDATE TRAINING -----	53
6.4	RETRAINING-----	53
6.5	AVAILABLE WEB-BASED FP TRAINING COURSES--	53
6.6	FALL PROTECTION TRAINING ROSTER -----	54
6.7	FALL PROTECTION TRAINING ROSTER FORM -----	56
7.0	FALL HAZARD PREVENTION AND CONTROLS -----	57
7.1	PREFERRED ORDER OF CONTROL MEASURES ----	57
7.2	FALL PROTECTION AND PREVENTION PLANS -----	58
7.2.1	FALL PROTECTION AND PREVENTION -----	58
	PLAN REQUIREMENTS	
7.2.2	INSTRUCTIONS FOR PREPARING THE PLAN-----	59
7.2.3	SAMPLE FALL PROTECTION AND PREVENTION ----	61
	PLAN (FORM)	
7.2.4	SITE SPECIFIC FALL PROTECTION AND -----	63
	PREVENTION PLAN CHECKLIST	
7.2.5	WHEN A COMPETENT OR QUALIFIED PERSON ----	64
	ARE REQUIRED TO DEVELOP FP&PP CHECKLIST	
8.0	FALL PROTECTION SYSTEMS, CRITERIA AND -----	67
	DESIGN REQUIREMENTS	
8.1	FALL PROTECTION SYSTEMS -----	67
8.2	FALL PROTECTION SYSTEM, CRITERIA AND -----	68
	REQUIREMENTS	
8.2.1	PREVENTION SYSTEMS -----	68
8.2.1.1	GUARDRAIL SYSTEM -----	68
8.2.1.2	COVERS -----	72
8.2.1.3	WORK-STANDS, STATIONARY WORK -----	73
	PLATFORMS & CATWALKS	
8.2.2	SAFETY NETS -----	74
8.2.3	FALL ARREST SYSTEM -----	75
8.2.3.1	SPECIFIC FALL ARREST SYSTEM -----	76
	REQUIREMENTS	
8.2.3.2	FALL ARREST SUBSYSTEMS AND -----	77
	COMPONENTS	
8.2.4	OTHE FALL PROTECTION SYSTEMS -----	88
8.2.4.1	HORIZONTAL LIFELINE -----	88
8.2.4.2	SINGLE ANCHOR VERTICAL LIFELINE -----	90
8.2.4.3	POSITIONING SYSTEM -----	92
8.2.4.4	RESTRAINT SYSTEM -----	93
8.2.4.5	SUSPENDED ROPE ACCESS -----	95
8.2.4.6	CLIMBING LADDER FA SYSTEM -----	95
8.2.4.7	WARNING LINE SYSTEM -----	96
8.2.4.8	DESIGNATED AREA METHOD -----	98
8.2.4.9	SAFETY MONITORING SYSTEM -----	98

August, 2013

	8.2.4.10 CONTROLLED ACCESS ZONE -----	99
9.0	FALL PROTECTION FOR SPECIFIC WORK -----	100
	APPLICATIONS	
9.1	COMMUNICATION TOWERS -----	100
9.2	TOWER ERECTION -----	100
9.3	ROOF WORK -----	101
9.4	LEADING EDGE WORK -----	102
9.5	SCAFFOLD WORK -----	102
9.6	SUSPENDED SCAFFOLDS -----	102
9.7	AERIAL LIFTING EQUIPMENT -----	103
9.8	CONFINED SPACE ENTRY -----	108
9.9	EXCAVATED TRENCHES OR HOLES MORE -----	108
	THAN SIX FEET DEEP	
9.10	COVERS -----	108
9.11	SAFE WORK PRACTICES ON LADDERS AND -----	109
	STAIRWAYS	
9.12	WORKING NEAR WALL OPENINGS -----	112
9.13	WORKING OVER WATER -----	112
9.14	AIRCRAFT MAINTENANCE -----	114
9.15	ELEVATED WORK AREA NEAR GUARDRAIL -----	114
9.16	OTHER ENGINEERED FP SYSTEMS -----	114
9.17	LADDER CAGES -----	115
10.0	GUIDANCE FOR RESCUE PROCEDURES -----	116
10.1	INTRODUCTION -----	116
10.2	BACKGROUND -----	116
10.3	GENERAL REQUIREMENTS -----	117
10.4	INITIATION OF RESCUE -----	117
10.5	FALL ARREST RESCUE PLANS AND PROCEDURES--	118
10.6	RESCUE EQUIPMENT INSPECTION -----	119
10.7	TRAINING REQUIREMENTS FOR RESCUE -----	119
10.8	PROCEDURES FOR REQUESTING RESCUE AND	
	MEDICAL ASSISTANCE -----	120
10.9	TRANSPORTATION ROUTES TO A MEDICAL	
	FACILITY-----	120
10.10	ANCHORAGES USED FOR RESCUE -----	120
10.11	SELECTIVE RESCUE EQUIPMENT AND SYSTEMS ---	120
10.12	REFERENCES RELATED TO RESCUE -----	122
10.13	FALL ARREST RESCUE PLANS -----	123
10.14	SAMPLE FALL-ARREST RESCUE PLAN (FORM)-----	125
10.15	SITE SPECIFIC FALL ARREST RESCUE PLAN	
	(CHECKLIST) -----	127
11.0	INSPECTION, MAINTENANCE, STORAGE, -----	128

August, 2013

	AND CARE PROCEDURES FOR FALL PROTECTION EQUIPMENT	
11.1	SPECIFIC EQUIPMENT INSPECTION -----	128
11.2	ADDITIONAL INSTRUCTIONS FOR ASSEMBLY, DISASSEMBLY, STORAGE AND INSPECTION-----	134
11.3	FALL PROTECTION EQUIPMENT INSPECTION CHECKLIST -----	136
11.4	FALL-ARREST SYSTEM AND EQUIPMENT CHECKLIST -----	138
12.0	TIE-OFF CONSIDERATIONS AND SELECTION OF SAFE ANCHORAGES -----	142
13.0	RESPONSIBILITY FOR DESIGN, INSPECTION, CERTIFICATION AND RE-CERTIFICATION OF ANCHORAGES -----	146
13.1	RESPONSIBILITY OF ANCHORAGE IDENTIFICATION, DESIGN AND CERTIFICATION -----	146
13.2	INSPECTION, CERTIFICATION, RE-CERTIFICATION OF ANCHORAGES -----	147
14.0	FALL PREVENTION CONSIDERATIONS DURING PLANNING AND DESIGN PHASE -----	149
14.1	INTRODUCTION -----	149
14.2	PLANNING AND DESIGN CONSIDERATIONS -----	150
14.3	FALL HAZARD IDENTIFICATION-----	151
14.4	RISK ASSESSMENT -----	152
14.5	RISK CONTROL -----	152
14.6	HIERARCHY OF CONTROL MEASURES FOR PLANNING AND DESIGN -----	153
15.0	GUIDANCE – FALL PROTECTION FOR AIRCRAFT MAINTENANCE AND INSPECTION WORK -----	154
15.1	INTRODUCTION -----	154
15.2	APPLICABILITY -----	154
15.3	PURPOSE -----	154
15.4	FALL PROTECTION SYSTEMS AND EQUIPMENT USED FOR AIRCRAFT MAINTENANCE AND INSPECTION WORK -----	154
15.5	APPLICABLE STANDARDS, REGULATIONS/SOP AND INSTRUCTIONS -----	156
15.6	APPLICATION OF OPERATIONAL RISK MANAGEMENT -----	156
15.7	GUIDANCE TO MEET CNAF FALL PROTECTION PROGRAM ADMINISTRATIVE REQUIREMENTS -----	156
15.8	FUNDING AND PROCUREMENT OF FP EQUIPMENT--	161
15.9	EXAMPLES OF FALL PROGRAM TEMPLATES -----	162

August, 2013

15.10	FALL PROTECTION FORMS/CHECKLISTS-----	183
15.11	COMMON TYPE OF AVIATION FP OPTIONS -----	187
16.0	FALL PROTECTION REQUIREMENTS FOR A/Es AND OTHER INSPECTORS CONDNDUCTING ROOF INVESTIGATION, ASSESSMENTS AND INSPECTION WORK -----	191
17.0	OTHER FALL PROTECTION MEASURES -----	202
18.0	ANSI Z359 FALL PROTECTION CODE/STANDARDS--	205
19.0	REFERENCES/HOW TO ACQUIRE INFORMATION ----	207
APPENDIX A	FALL PROTECTION COMPARISON AMONGVARIOUS OSHA STANDARDS, EM 385-1-1 AND NAVY REQUIREMENTS -----	209
APPENDIX B	TOTAL FALL DISTANCE -----	227
B.1	MATHEMATICAL PROBLEM, CALCULATING TOTAL FALL DISTANCE -----	227
B.2	CALCULATING THE CLEARANCE -----	227
B.3	TOTAL FALL DISTANCE SCHEMATICS -----	228
APPENDIX C	DISCUSSION OF EXAMPLES/PROBLEMS AND SOLUTIONS TO FALL HAZARDS -----	232
APPENDIX D	MAN OVERBOARD PLAN -----	236
APPENDIX E	GUIDANCE DOCUMENT - DESIGN CONSIDERATIONS FOR MANAGEMENT OF FALL HAZARDS -----	240
APPENDIX F	COURSE SYLLABUS FOR COMPETENT PERSON FOR FALL PROTECTION TRAINING -----	264

August, 2013

DON FALL PROTECTION GUIDE FOR NAVY AND MARINE CORPS SHORE FACILITIES

1.0 INTRODUCTION

1.1 PURPOSE

This Guide establishes criteria and requirements for developing and managing Fall Protection programs to protect all Navy and Marine Corps personnel (military and DON civilians) at Navy and Marine Corps shore activities.

1.2 BACKGROUND

Falls from heights are a leading cause of work-related injuries and fatalities. They are the leading cause in construction and the fourth most common cause in general industry. The DON continues to experience serious fall related mishaps, which lead to reduced readiness and productivity, as well as high medical and compensation costs resulting from these mishaps. According to Bureau of Labor Statistics (BLS), there were 666 fatalities due to slips, trips and falls in 2011 accounting for 14% of total work fatalities. Falls to lower level totaled 541 fatalities and falls on the same level accounted for 108 fatalities. In the United States, two to three fatalities from falls occur each working day. Furthermore, thousands of workers suffer injuries due to falls with lost time from work. Half of fall fatalities occurred in the construction industry. BLS data shows that fall fatalities from roofs are the most common, followed by falls from ladders, scaffolds, staging, and other surfaces. Aside from tragic loss of life and suffering to victims and their families, workers are very expensive to train to perform work efficiently. On the average, a single fall fatality costs approximately \$800,000 to \$2,400,000 (in 2011 dollars, from the latest data available). The average cost of a single injury due to a fall is over \$30,000. Additionally, falls is the most cited violation by Occupational Safety and Health Administration (OSHA). The intent of this guide is to establish criteria, requirements and best practices for developing and managing Fall Protection programs in order to heighten awareness and protect all DON personnel exposed to Fall-Hazards in the workplace. Falls are preventable. Careful planning and preparation lay the necessary groundwork for an accident-free workplace.

1.3 APPLICATION

This guide applies to all Navy and Marine Corps shore activities (Including activities not governed by OPNAVINST 5100.19 series) where there is a need for a Fall Protection program to ensure the safety of all personnel (military and DON civilians, worldwide). It provides information on standards, regulations, formal criteria and requirements, for the protection of personnel and workers working at heights and exposed to Fall-Hazards.

1.4 SCOPE

The scope of this guide is to develop a managed Fall Protection program and to provide the requirements and criteria for Fall Protection for potentially affected workers exposed to Fall-Hazards while conducting Navy and Marine Corps Activities.

This guide provides:

- a. Definitions applicable to Fall Protection and rescue.
- b. Criteria and requirements for a managed Fall Protection program, a sample of a written program and program compliance audit checklist.
- c. The duties, responsibilities and qualifications of personnel involved in the managed Fall Protection program.
- d. The requirements for Fall-Hazard survey and assessment process including the preparation of Fall-Hazard survey report and instructions for conducting the surveys.
- e. The training requirements for all personnel involved in the Fall Protection program including methods of training.
- f. Fall-Hazard prevention and controls including the preferred order of control measures or the hierarchy of controls, Fall Protection and prevention plan criteria and requirements, sample of the plan and site specific plan checklist.
- g. Various Fall Protection systems, criteria and requirements.
- h. The Fall Protection guidelines for specific common working conditions and applications (Working on roofs, communication towers, scaffolds, etc).
- i. Guidelines for fall rescue procedures, a sample rescue plan for Fall-Hazard control and a site specific fall arrest rescue plan checklist.
- j. Requirements for Fall Protection equipment inspection, maintenance, storage, and care procedures including equipment inspection checklist.
- k. Tie-off considerations and identification, use, selection of non certified anchorages, certification and re-certification of certified anchorages.
- l. Considerations for management of fall hazards and responsibilities of architects and engineers during planning, design, construction, operations and maintenance activities.
- m. Fall Protection guidelines for aircraft maintenance and inspection work.
- n. Fall Protection requirements for architects/engineers and other inspectors conducting inspection, investigation and assessment work on roofs.
- o. Other protection requirements including falling object protection, hard hats, lock-out tag-out, etc.
- p. Information regarding American National standards Institute, ANSI Z359 Fall Protection Code and Standards.

1.5 NAVY AND MARINE CORPS FALL PROTECTION POLICY

According to OPNAVINST 5100.23 Series, Navy Safety and Occupational Health Program Manual Chapter 13, and MCO 5100.29B, Marine Corps Safety Program and NAVMC DIR 5100.8, Marine Corps OSH Manual every Navy and Marine Corps shore Command/Activity having personnel working at height, exposed to Fall-Hazards and using Fall Protection equipment is responsible for establishing, implementing and managing a Fall Protection program, which includes identification and elimination or control of Fall-Hazards. Navy and

August, 2013

Marine Corps activities are responsible for assigning personnel duties and responsibilities; surveying and assessing Fall-Hazards; training of personnel; providing prevention and control measures; proper installation and use of Fall Protection systems; inspecting the equipment; auditing and evaluation;; and the availability of rescue equipment with accompanying rescue procedures. Fall Protection must be provided to Navy and Marine Corps civilians and military personnel exposed to Fall-Hazards on any elevated walking working surface with unprotected sides, edges of roofs, or floor opening, from which there is a possibility of falling four feet or more to lower level; or where there is a possibility of a fall from any height onto dangerous equipment, into hazardous environment, or onto an impalement hazard.

The Regional Commander, , Commanding Officer/Director, Officer-In-Charge of the Navy Activity as well as Marine Corps Major Commands and Subordinate Commands are responsible for establishing and implementing a Fall Protection program.

1.6 ACTIVITY FALL PROTECTION POLICY

Each activity may prescribe supplementary requirements for special conditions above and beyond the Navy and Marine Corps policy stated in paragraph 1.5 above. Development of an activity policy statement will provide general guidance and requirements and delineate responsibilities at the Command. The activity policy should emphasize management commitment to provide a safe work environment for personnel working at heights and that safety of personnel during performance of their work is of the utmost importance.

1.7 BASIC REQUIREMENT FOR FALL PROTECTION

The threshold limit for providing Fall Protection is mandated by OPNAVINST 5100.23 Series, MCO 5100.29 Series and the US Code of Federal Regulations (CFR).

The standard Fall Protection threshold height for federal employees (military and civil service) on US Navy and Marine Corps Facilities (worldwide) is 4 feet as per OPNAVINST 5100.23 Series, MCO 5100.29 Series and the General Industry Standards, 29 CFR 1910, Subpart “D”. Federal employees on public shipyards shall also adhere to the threshold height no greater than 4 feet when performing Ashore work as per OPNAVINST 5100.23 Series, MCO 5100.29 Series and 29 CFR 1910. For Federal employees performing non-ashore work on public shipyards shall adhere to the threshold height of 5 feet as per the Shipyard Employment Standard 29 CFR 1915.

At construction sites, workers (**contractors only**) shall adhere to the threshold height no greater than 6 feet, as per US Army Corps of Engineers (USACE), Safety and Health Requirements Manual EM 385-1-1, and 29 CFR 1926.500, Subpart ‘M’, Fall Protection in Construction Industry. When Navy and Marine Corps personnel visit construction sites to inspect contractor’s work, they may comply with the 6 foot threshold height because it would be infeasible to install guardrails at 4 foot height just for Navy and Marine Corps Personnel, when the OSHA Standards require a 6 foot threshold height for construction workers.

August, 2013

For information only, the following is a table indicating the threshold limit for various industries or standards:

<u>Industry</u>	<u>Feet</u>	<u>Standard Regulations Source</u>
<u>Contractors Construction</u>	<u>6</u>	<u>EM 385-1-1</u> <u>29 CFR 1926.500</u>
<u>General Industry</u>	<u>4</u>	<u>29 CFR 1910.23</u>
<u>Shipyard (Non-Ashore work)</u>	<u>5</u>	<u>29 CFR 1915.159</u>
<u>Marine Terminals/</u>	<u>4</u>	<u>29 CFR 1917.112</u>
<u>Long-Shoring</u>	<u>8</u>	<u>29 CFR 1918</u>

Shore activities may prescribe more stringent threshold requirements for federal employees as required, due to the site-specific facility needs.

1.8 COMPLIANCE

29 CFR 1960.16 and Section 19 of the Occupational Safety and Health Act (OSH Act) of 1970 and Executive Order 12196 prescribe requirements for federal employment occupational safety and health programs and contains provisions to assure safe and healthful working conditions for federal employees. Under Section 19 of OSHA Act and 29 CFR 1960.16, (for Federal Agencies), Occupational Safety and Health (OSH) programs shall be consistent and in compliance with the standards promulgated under Section 6 of the OSH Act of 1970. Section 6 of OSH Act directed by rule the Secretary of Labor to promulgate the Occupational Health and Safety Standard 29 CFR 1910.

Navy and Marine Corps personnel at shore Facilities shall comply with the 29 CFR 1910 requirement of four feet as stated under Subpart D, Walking-Working Surfaces, unless there are other alternate promulgated standards that are more specific to an Activity, Command or industry, such as the six-foot requirement for DON contractors performing construction and demolition work. Any deviation from the 4-foot threshold height shall be approved by the Command Competent Person for Fall Protection.

Note 1. There is no safe distance from an unprotected side or edge of a roof or floor. The distance alone is ineffective to protect personnel from unprotected sides and edges.

Note 2. There is no minimum time duration that allows exclusion of Fall Protection requirements. (e.g., if a 2 minute job requires 15 minutes to establish Fall Protection).

Therefore, Fall Protection must be provided to DON civilians and military personnel exposed to Fall-Hazards on any elevated walking/working surface with unprotected sides, edges, or floor openings from which there is a possibility of falling 4 FEET or more to lower level including working from fixed ladders; or where there is a possibility of a fall from any height, onto dangerous equipment, into hazardous environment or

onto an impalement hazard.

Exceptions: (1) When climbing OSHA compliant ladders, or (2) when erecting or dismantling supported scaffolds when it is determined by a Competent Person after conducting an evaluation, that providing Fall Protection is not feasible or creates a greater hazard (for example: When it is necessary to erect scaffolding before erection of the structure, and requiring the scaffold structure to be erected or put in place.)

All regulations and standards for Fall Protection and health and safety contain minimum requirements. DoD Instruction 6055.1 does not preclude DoD Authorities from prescribing supplementary requirements for special conditions, over which the DoD itself, or in coordination with other Federal Agencies, exercises statutory authority for safety and health matters. Generally, DoD Instruction 6055.1 does not apply to DoD contractors, except for provisions covering inspection requirements.

1.9 COMPARISON AMONG OSHA FALL PROTECTION STANDARDS, DON REQUIREMENTS AND USACE EM 385-1-1

Appendix A provides comparison among various OSHA Fall Protection standards (Construction and General Industry), OPNAVINST 5100.23 Series, MCO 5100.29 Series, NAVMC DIR 5100.8 and the USACE EM 385-1-1 Series, Fall Protection Requirements. When all the Fall Protection standards and regulations specifically OPNAVINST 5100.23 Series, FP program chapter 13, and the USACE EM 385-1-1, Section 21 requirements are compared, they are similar in the application and use of Fall Protection systems and equipment. The only difference is the threshold limit where Fall Protection is required (4, or 6 ft height). These threshold heights only affect the level at which temporary guardrails and work platforms are installed or used. According to the Building Codes, if there is a break of 30 inches (2 ½ feet) or more between levels, the edges must be guarded by permanent guardrails. Fall-arrest equipment cannot be used at these low elevations (i.e., 4 or 6 feet). The minimum clearance required for safely using fall-arrest systems is approximately 11 feet (depending on the length and type of the energy absorbing lanyard used, [e.g., Self-retracting Devices], the height of anchorage point, and available clearance. Other fall-arrest systems will require more clearance. Work platforms, with minor modifications, can be adjusted to the required threshold height. A positioning system will require a minimum of 8 feet or more below the tie-off point. Additionally, restraint, travel restraint, warning line systems or designated area method that may be used at any elevation and will not be affected by the prescribed threshold limits of 4 or 6 ft, because when using those systems personnel will not be exposed to a Fall-Hazard. The only effect the threshold height limitations will have on safe walking working surfaces is the installation of temporary guardrails, existing loading docks, and parts of ramps above 4 feet.

1.10 INSTRUCTIONS, REGULATIONS and STANDARDS

1.10.1 OPNAVINST. 5100.23 Series, Navy Safety and Occupational Health Program Manual; Chapter 13, Fall Protection Program;

August, 2013

1.10.2 US Army Corps of Engineers (USACE), Safety and Health Requirements Manual, EM 385-1-1, current edition; shall be included and enforced on all DOD contracts involving construction, dismantling, demolition or removal work. Contractors performing such work shall comply with all pertinent provisions of the latest version of the manual (FAR 52.236-13 Accident Prevention);

1.10.3 29 CFR, PART 1926.500, Subpart M, Fall Protection Requirements in the Construction Industry;

1.10.4 29 CFR, PART 1910, Occupational Safety and Health Standards;

1.10.4.1 Notices of Proposed Rulemaking, 29 CFR 1910 (May 2010) – Walking and Working Surfaces and Personal Protective Equipment (FP Systems);

1.10.5 29 CFR PART 1915, Occupational Safety and Health Standards for Shipyard Employment;

1.10.6 29 CFR 1917, Marine Terminals;

1.10.7 29 CFR PART 1918, Safety and Health Regulations for Longshoring;

1.10.8 29 CFR PART 1960, Basic Program Elements for Federal Employee Occupational Safety and Health Programs;

1.10.9 Department of Defense Directive 6055.1, Occupational Safety and Health Program;

1.10.10 American National Standards Institute (ANSI):

1.10.10.1 ANSI/ASSE Z359 Fall Protection Code/Standards,
(See Chapter 17 for description of these standards);

1.10.10.2 ANSI/ASSE A1264.1 (R2007): Safety Requirements for Workplace Walking/Working Surfaces and Their Access, Workplace Floor and Wall Openings, Stairs and Temporary Guard Systems;

1.10.10.3 ANSI/ASSE A14.3 (R2008) Safety Requirements for Fixed Ladders;

1.10.11 NAVFACINST 5100.11J Safety and Health Program Manual

1.10.12 MCO 5100.29B, Marine Corps Safety Program

1.10.13 NAVMC DIR 5100.8, Marine Corps Occupational Safety and Health (OSH) Program Manual; Chapter 18, Fall Protection Program

End of Section

2.0 DEFINITIONS

Activation Distance: The distance traveled by fall-arrester or the amount of line paid out by self-retracting lanyard from the onset of a fall to the point where the fall arrester or self-retracting lifeline begins to apply a braking or stopping force.

Active Fall Protection system: A Fall Protection system that requires end-users to wear or use Fall Protection equipment and that requires fall protection training.

Adjuster: A component that provides a means to vary the length of strap, webbing or rope.

Anchorage: A secured structure that can safely withstand forces exerted by the activation of Fall Protection and rescue equipment. The structure can be in the form of a beam, girder, column, or floor. Anchorage is either engineered or improvised.

Anchorage Connector: A component or subsystem by which Fall Protection or rescue equipment is secured or attached to the anchorage. This can include a steel cable sling, tie-off adapter (anchor strap), load-rated hoist ring designed for construction applications, tripod, davit arm, or any other device designed to suspend human loads and capable of withstanding forces generated by a fall.

Anchorage System: A combination of anchorage and anchorage connector.

Arresting Distance: The total vertical distance required to arrest a fall. Includes activation and deceleration distance. Arresting distance does not include free-fall distance.

Arresting Force: The force exerted on a worker, when a fall protection system stops the fall. The magnitude usually expresses the peak force experienced during a fall.

Assigned Safety Person (Spotter): An employee assigned to check periodically (at least every 5 minutes) visually or verbally to assure that an end-user has not fallen and is suspended in his/her harness. This assigned safety person shall have the ability to make quick contact with the jurisdictional public/Government-emergency response agency. This is also known as the "Buddy System".

Assisted Rescue: A planned means of rescue, requiring the assistance of others.

Authorized Person: See the definition of End-user.

Authorized Rescuer: A person who is trained on rescue procedures and assigned by the Command to rescue an end-user who may require rescue.

Automatic Descent Control Device: A load lowering device or mechanism that once engaged will automatically control pay-out speed of line or descent speed under load. Some automatic controlled descent devices have self-retracting lanyard capability.

August, 2013

Available Clearance: The distance from the walking working surface or platform to the nearest obstruction that the end-user might contact during a fall.

Body Belt: A strap with means for securing it about the waist. **(Use in a personal fall-arrest system is prohibited).**

Body Harness: Means of configuration of connected straps secured about the employee in a manner that will distribute the arresting forces over at least the upper thighs, waist, shoulders, chest and pelvis, with means for attaching a lanyard to other components of the personnel fall-arrest system. Full-body harness is the only body support device allowed by OSHA or ANSI when a free-fall distance exceeds two feet.

Boatswain's (Boson's) Chair: A single-point adjustable suspension scaffold consisting of a seat or strap designed to support one employee in a sitting position. The seat is made of a plywood or strap independently suspended from an anchorage, and the employee, using full-body harness attached to a separate lanyard or lifeline attached to an independent anchorage, may sit to help alleviate the pooling of blood in the legs.

Brake Bar Rack: A series of smooth bars connected together in parallel in which a synthetic rope is intertwined so that the friction of the rope against the bars controls the descent of a lowering device (often used in a rope rescue system).

Buckle: A connector used for attaching the strap or webbing segments together or to themselves.

Capacity: The maximum weight that a component, system, or subsystem is designed to hold. This includes combined weight of the user, clothing, tools and other objects carried by the end user.

Cable Grab: See fall-arrester.

Carabiner: A connector component generally consisting of an oval- or trapezoidal-shaped body with a closed gate or similar arrangement. **Only self-locking carabiners are acceptable for use.** **Certification:** The act of attesting in writing that the established criteria have been met.

Certified: An act or process resulting in documentation that determines and attests to criteria that meet the requirement of ANSI Standard. Such act or process may be carried out by testing or applying proven analytical methods, or both, under the supervision of a qualified person for fall protection or other entity (i.e. Professional Engineer).

Certified Anchorage: An anchorage for fall arrest, positioning, restraint or rescue system that a Qualified Person for fall protection certifies to be capable of supporting the potential fall forces that could be encountered during a fall.

Clearance: The distance from a specified reference point, such as the working platform or anchorage of a fall-arrest system, to the lower level that a worker might encounter during a fall.

August, 2013

Clearance Requirements: The distance below the end use that must be clear of obstructions in order to ensure that the end user does not encounter any object or obstruction during a fall.

Climbing Ladder Fall Arrest System: See “Ladder Climbing (Safety) Device”.

Competent Person (CP) for Fall Protection: A person designated by the Command to be responsible for the immediate supervision, implementation and monitoring of the Fall Protection program, who through training knowledge and expertise is capable of identifying, evaluating and addressing existing and potential Fall-Hazards and in the application and use of personal fall-arrest and rescue system, or any component thereof, AND who has the authority to take prompt corrective measures to eliminate or control the hazards of falling.

Connector: A device used to couple (connect) parts of the personal fall-arrest system together. It may be an independent component of the system, such as a carabiner, or it may be an integral component of part of the system (such as a buckle or D-ring sewn into a body belt or body harness, or a snap-hook spliced or sewn to a lanyard or self-retracting lanyard).

Connecting Means: The method to connect body support to an anchorage, such as a lanyard, snaphook or a carabiner for the purpose of providing protected mobility for an elevated work task.

Connecting Subsystem: An assembly, including the necessary connectors, comprised of components, subsystems or both, between the anchorage connector and the D-ring of body harness.

Controlled Access Zone (CAZ): A zone to restrict access to unprotected edge work. The CAZ is bounded by a control line and should run the full length of the unprotected edge and connect on each side to a guard or wall. The control line can be made of rope, wire, tape, or equivalent material and shall be supported by stanchions and marked with a highly visible material.

Deceleration Device: Any mechanism, such as a fall-arrester (rope grab), rip-stitch lanyard, specially-woven lanyard, tearing or deforming lanyards, automatic self-retracting devices, etc., which serves to dissipate a substantial amount of energy during a fall-arrest, or otherwise limit the energy imposed on an employee during fall-arrest.

Deceleration Distance: The vertical distance, measured between the location of the user’s fall-arrest attachment point (dorsal D ring) at the onset of fall-arrest forces during a fall (and after the fall-arrest attachment point comes to a complete stop), is the additional vertical distance a falling employee travels (excluding dynamic elongation and free-fall distance) before stopping, from the point at which the deceleration device begins to operate or deploy.

Designated Area Method: A distinct area of a walking-working surface, delineated by a perimeter warning line, in which temporary work may be performed without additional Fall Protection. **The designated area method is used only for general industry work.**

D-ring: An integral “D” shaped connector typically used in harnesses, lanyards, energy absorbers, lifelines, and anchorage connectors as an attachment point.

August, 2013

Descent Controller: A device designed to be used by one worker for personal descent to lower another person from an elevation. Descent control may be used for egress, positioning or both.

End-user of Fall Protection (Authorized Person): A person who has been trained in the use of assigned Fall Protection equipment, including hands-on training and practical demonstrations in a typical Fall-Hazard situation, and uses personal fall-arrest or restraint/positioning equipment while performing work assignments at heights.

Energy (Shock) Absorber: A component whose primary function is to dissipate energy and limit deceleration forces that the system imposes on the body and the anchorage system during fall-arrest.

Energy Absorber, Horizontal Lifeline. An energy absorber that is attached to one of the end anchorages or anchorage connectors of a horizontal lifeline subsystem.

Energy Absorber, Personal. An energy absorber that is attached to a harness.

Energy Absorber, Single Anchor Vertical Lifeline. An energy absorber that is attached to the top anchorage or anchorage connector of a single anchor vertical lifeline subsystem.

Engineered Anchor: An anchorage designed and approved by a Qualified Person.

Evacuation harness: A component for rescue purposes consisting of elements designed and constructed so that the rescue subject is securely held during the rescue process. Evacuation harness is a special harness.

Failure: Load refusal, breakage, or separation of component parts. Load refusal is the Point at which the ultimate strength is exceeded.

Fall-arrest System: A combination of equipment and components such as full-body harnesses, lanyards, deceleration devices, anchorages, horizontal or vertical lifelines connected together, designed to stop a person from striking a lower level or an obstruction during a fall.

Fall arrester: A device that travels on a lifeline and will automatically engage or lock onto the lifeline in the event of a fall. A rope grab is one example of fall arrester. .

Fall Hazard: Any location where a person is exposed to a potential free fall.

Fall Prevention: The elimination and minimization of potential Fall-Hazards, lessening the chance of employee exposure to falls. Any same-level means used reasonably to prevent exposure to a Fall-Hazard; examples of fall prevention are guardrails, walls, floors, and area isolation. Also called passive fall protection system.

August, 2013

Fall Protection: Action and procedures to protect a worker effectively from Fall-Hazards. Any equipment, device or system that prevents an accidental fall from elevation or that mitigates the effect of such a fall.

Fall Restraint: See “Restraint System”.

Fall Protection Program Manager: A person assigned by the command to be responsible for developing and managing the Fall Protection program at a Navy Command.

Force Factor: The ratio of peak arresting force of a rigid mass to a human body having the same weight, both falling under identical conditions.

Forced Roll-out: An action by which the gate of a **locking** snap-hook or carabiner is loaded beyond its design strength, forcing it to fail and disengage from the component to which it was attached.

Free-fall: The act of falling before a personal fall-arrest system begins to apply force to arrest a fall.

Free-Fall Distance: The vertical distance from the onset of a fall to a point where a fall-arrest system is activated or engaged. (This is the vertical distance measured from the fall-arrest attachment point on the employee’s body harness at the onset of the fall to the point just before the system begins to apply force to arrest the fall. This distance excludes deceleration distance, and lifeline/lanyard elongation which are exerting deceleration forces, but includes any deceleration device slide distance or self-retracting lifeline/lanyard extension before they operate and fall-arrest forces occur.)

Frontal D-Ring Attachment: An attachment element affixed to the full body harness within the vertical seven-inch sternum (breastbone) area that is designed to withstand dynamic fall arrest, restraint, and post-fall suspension forces.

Full-body harness: See the definition of “Body Harness”.

Guardrail System: A passive fall protection system of horizontal rails and vertical posts that prevent a person from reaching a fall edge. Guardrail systems typically have a top rail, a mid rail and posts and toeboard.

Horizontal Lifeline: A component of a horizontal lifeline subsystem, consisting of a flexible line with connectors or other coupling means at both ends for securing it horizontally between two anchorages or anchorage connectors.

Horizontal Lifeline Subsystem: An assembly, including the necessary connectors, comprised of a horizontal lifeline component and, optionally, of: a) An energy absorber component or, b) A lifeline tensioner component, or both. This subsystem is normally attached at each end to an anchorage or anchorage connector and may also contain one or more intermediate anchorages. The end anchorages have the same elevation.

Horizontal Track System: A form of rigid rail system that typically encloses a trolley inside a formed

channel or track.

Hybrid Component: An integral assembly of elements or components, or both, intended to perform more than one function in the system.

Ladder Climbing (Safety) Device: A device or climbing sleeve, connected to the front D-ring on the climber's full-body harness, which slides up or down a rigid rail or cable used as a fall arrest system. Should a fall occur; the device is designed to lock by inertia or cam action to arrest the fall.

Lanyard: A flexible line of rope, wire rope, or strap that usually has a connector at each end for connecting the body support and to a fall arrester, energy absorber, anchorage connector, or anchorage

Leading Edge: The unprotected side and edge that exposes a worker to a Fall-Hazard. It can be the edge of a floor, roof, or formwork for a floor or other walking/working surface where the edge changes location as additional floor, roof, decking or formwork sections that are placed, formed, or constructed.

Lifeline: A component consisting of a flexible line which is connected either to an anchorage at one end, and hangs vertically (single anchor vertical Lifeline), or is connected to anchorage at both ends and stretches horizontally (Horizontal Lifeline); both of which serve as means for connecting other components of a personal fall-arrest system.

Man Overboard Plan: A man overboard plan is an emergency plan for rescuing personnel if they accidentally fall into the water.

Manual Descent Controlled Device: A load-lowering device or mechanism that, once engaged, requires manual attention to control pay-out speed of line, or descent speed under load.

Manual Fall Arrester (Manual Rope Grab): A fall arrester that will remain locked where it has been positioned on a VLL until deliberately repositioned by a worker.

Marking: Any sign, label, stencil, plate or the like containing information or guidance.

Maximum Arrest Force (MAF): The peak force exerted on the body when a Fall Protection system arrests or stops a fall.

Non-Certified Fall Protection Anchorages: An unquestionably strong anchorage that a Competent Person judges to be capable of supporting the predetermined anchorage strength as prescribed by OSHA Standards and ANSI/ASSE Fall Protection Code. Non-Certified anchorages are used for fall-arrest, work positioning, travel restraint, or rescue.

Orthostatic Intolerance (suspension Trauma): The development of symptoms as a result of suspension in a full-body harness, such as light-headedness, palpitations, tremulousness,

August, 2013

poor concentration, fatigue, nausea, dizziness, headache, sweating, weakness, and occasionally fainting and unconsciousness.

Passive Fall Protection System: A system that does not require a worker to use or wear personal fall-arrest equipment. Examples include safety nets, guardrails, parapet walls, etc.

Personal Energy Absorber: See “Energy Absorber”.

Personal fall-arrest System: Assembly of components and subsystems used to arrest an end-user falling from height. It consists of an anchorage system, connecting means, and full body harness, and may include a lanyard, deceleration device, lifeline, or suitable combination of these. **Use of a body belt in a personal fall-arrest system is prohibited.**

Positioning System: A combination of equipment including a full-body harness rigged to allow the end-user to work with both hands free while being supported on an elevated vertical work surface.

Positioning Lanyard: A lanyard used to transfer forces from a body support to an anchorage or anchorage connector in a positioning system.

Pre-Incident Plan: A formal written plan, prepared jointly by the host Navy activity and the fire emergency responders, containing factors that need to be evaluated when assessing the potential situations that could affect a facility during emergency conditions.

Primary System: In fall protection terminology, the main mechanism that allows a worker to maintain his or her desired position.

Qualified Person (QP) for Fall Protection: A person with a recognized engineering degree or professional certificate and with extensive knowledge, training, and experience in the Fall Protection and rescue field, who is **capable designing, analyzing, evaluating, and specifying Fall Protection and rescue systems and equipment.**

Rescue: Process of evacuating a person or persons to a safe location where they also may receive medical attention.

Rescue Ladder: A flexible ladder with rigid rungs and either synthetic webbing or wire rope side rails which can be temporarily hung next to the end-user working at heights, or can be lowered to an end-user suspended in a harness, to allow him to climb back up to the working surface (or at least stand on the ladder while awaiting rescue, allowing the necessary circulation of the blood to the entire body while an assisted rescue is being commenced).

Rescue Lanyard: A component consisting of flexible line of rope or strap, which usually has a connector at each end for connecting the body support to components of a rescue system. A rescue lanyard is a special lanyard.

Rescue Plan (Fall-arrest): A written plan that describes the rescue method and procedures to be used to rescue an end-user of Fall Protection, who may have fallen from a height and be

August, 2013

suspended in a full-body harness. The suspended worker may have been injured or incapacitated prior to, or as the result of, the fall (See section 10.13 for a sample fall-arrest rescue plan).

Restraint System: A combination of devices designed to restrain an end-user from reaching an exposed Fall-Hazard. The system consists of a full-body harness that can be secured around a worker and attached to a load-bearing anchorage in order to restrict travel and limit Fall-Hazards. The strap can be single or multiple.

Rigid anchorage subsystem: An anchorage system, such as a rigid rail or trolley system or a single point of attachment, which does not appreciably deflect, deform, or stretch when a fall-arrest impact occurs.

Rigid Rail System: A fall protection system that uses one or more trolleys on a horizontal track (often an I-beam or slotted tube).

Roll-out: An action by which a snap-hook or carabiner unintentionally disengages from another connector or object to which it is attached.

Rope Access: A system consisting of two lifelines independently anchored at the top to protect the authorized person from falling. The ropes directly suspend the person. The technique is used on buildings, bridges, and other structures for conducting inspection, cleaning, and painting.

Rope (or Strap) Adjuster: A mechanical means of readily moving a vertical line attachment or changing the position of an intermediate anchorage device between an anchorage (connector) and a body support while loaded with the authorized person's weight or partial weight while leaning.

Rope Grab: See Fall-arrester.

Rope, Synthetic: A construction of bundled manmade yarns, fibers, or filaments forming a strong flexible line.

Rope, Wire: A plurality of drawn wires forming strands laid helically over an axis or core.

Runway: 1. a passageway for a person, elevated above the surrounding floor or ground level, such as a foot-walk along shafting or a walkway between buildings.

2. Elevated crane rails upon which an overhead electric crane travels.

Safety Strap/Relief Step Strap: A coiled strap (in a pouch) attached to the lanyard which is manually deployed after a fall, and allows the end-user to insert one foot (or two feet, depending on the style) into the loop step and stand allowing the necessary circulation of blood to the entire body, while an assisted rescue is being commenced.

Safety Net System: A horizontal or semi horizontal cantilever-style barrier that uses netting system to stop falling workers before they make contact with a lower level or obstruction.

August, 2013

Sag: The distance the wire rope or synthetic cable of a horizontal lifeline deviates from the horizontal plane established by the end anchorage. This is defined by the line between two anchorages, measured downward at the mid-point of the wire rope or cable.

Self-Retracting Device (SRD): A device that contains a drum wound line that automatically locks at the onset of a fall to arrest the user, but that pays out from and automatically retracts onto the drum during normal movement of the person to whom the line is attached. After onset of a fall, the device automatically locks the drum and arrests the fall. Self-retracting devices include self-retracting lanyards (SRL's), self-retracting lanyards with integral rescue capability (SRL-R's), and self-retracting lanyards with leading edge capability (SRL-LE's) and, hybrid combinations of these.

Self-Retracting Lanyard (SRL): A device suitable for applications where during use, the device is mounted or anchored such that possible free fall is limited to 2 ft or less.

Self-Retracting Lanyard with Integral Rescue Capability: An SRL that includes integral means for assisted-rescue via raising or lowering the rescue subject.

Self-Retracting Lanyard with Leading Edge Capability (SRL-LE): A self-retracting device, used for horizontal applications, which is mounted or anchored at "foot" level and where there is the possibility of free-fall. The device includes integral means to withstand impact loading of the line contiguous with a sharp or abrasive edge during fall-arrest and for controlling fall-arrest forces on the user. The device can also be used for vertical applications where it is mounted overhead.

Seat Sling: A seat sling designed for attachment to a full-body harness, designed so that a worker may sit for a short period of time without pooling of blood in the legs.

Secondary Fall Protection System: One or more means of fall protection, as defined by these standards, configured as a supplement or as backup to protect a worker from a potential fall if the primary system fails.

Self/Manual Deploying Rescue Ladder: A coiled webbing rescue ladder (in a pouch) connected to the lanyard or anchorage which either self-deploys during a fall, or is manually released by the end-user after a fall, and is left dangling next to the suspended end-user. This allows the end-user to climb back up to the anchorage (or at least simply stand in the ladder, allowing the necessary circulation of blood to the entire body while an assisted rescue is being commenced).

Shock Absorber: See Energy Absorber

Single Anchor Vertical lifeline (VLL): A vertically suspended flexible line connected at the upper end for fastening to an overhead anchorage and along which a fall-arrester travels

Snaphook: A connector comprised of a hook-shaped body with a normally closed gate or similar arrangement, which may be opened to permit the hook to receive an object, and when released, automatically close to retain the object. **Only self-locking (single- or double-locking) snaphooks are acceptable for use.**

August, 2013

Strap: A length of webbing that may be incorporated in a harness, lanyard or other component or subsystem.

Suspension: The act of supporting 100% of a user's body weight, including equipment, for the purpose of accessing a work location with one or two points of contact.

Suspension Trauma (Harness-induced Pathology): Where the body is at rest in a vertical state with the lower body motionless, and blood begins to pool in the lower extremities because the muscles in the legs are not contracting on the veins and helping the blood back to the heart (against gravity). Blood is not properly circulated, the individual's blood pressure drops, the brain does not receive adequate blood flow and unconsciousness follows.

Suspension Trauma Safety Steps/Relief Step Strap: A coiled strap (in a pouch) attached to the harness which is manually deployed after a fall to help prevent the effects of suspension trauma by allowing the end-user to insert one foot (or two feet, depending on the style) into the loop step and stand up allowing the necessary circulation of blood to the entire body, while an assisted rescue is being commenced.

Suspension Seat: An arrangement of straps in a harness used to provide a body support and permit leaning or sitting while working...

Swing fall: A pendulum-like motion that can result from moving horizontally away from, or toward, a fixed anchorage, and falling. Swing falls generate the same amount of force when falling the same distance vertically. Swing fall has the hazards in both the horizontal direction (swinging into obstruction) and vertical direction (falling onto obstructions or ground).

Synthetic Rope Tackle Block: A load lifting and/or lowering device that does not include a winding or traction drum but uses pulleys to achieve a mechanical lifting advantage (often used in a rope rescue system).

Testing, Qualification: The controlled application of test conditions to a product specimen randomly selected from the initial production lot, and the recording of observed effects, for the purpose of determining the product's compliance with the requirements of these standards. When the terms "testing" or "tests" are used in the Z359 standards, those terms shall denote qualification testing or qualification test(s), not developmental or verification testing or test(s) unless otherwise specified.

Testing, Verification: The controlled application of test conditions to a product specimen sampled from ongoing production lots (after qualification testing), and the recording of observed effects, for the purpose of confirming the product's continuing compliance with the requirements of these standards. Proof load testing is a type of verification testing.

Toeboard: A low protective barrier to prevent the fall of materials and equipment to lower levels and provide protection from falls for personnel.

Total Fall Distance: The total vertical distance fallen by the worker using a fall-arrest system between the onset of a fall and the instant when the worker first achieves zero vertical velocity; or the vertical distance fallen by an end-user connected by a fall-arrest system to an anchorage measured from the walking/working surface and extending downward to a position

August, 2013

after the fall is arrested. The total fall distance includes the sum of the free-fall, elongation, and deceleration distances of the system.

Travel Restraint: See restraint system.

Travel Restraint Lanyard: A lanyard used to transfer forces from a body support to an anchorage or anchorage connector in a travel restraint system.

Trolley: A mobile anchorage device that travels along a track (horizontal track system), structural beam (rigid rail system), or cable (HLL system).

Warning Line System: A barrier erected on roof to warn workers that they are approaching an unprotected side or roof edge, and which designates an area where roof work may take place without the use of guard, fall-arrest, or safety net systems to protect workers in the area. Work performed outside barriers will require Fall Protection. A warning line system is used during construction work.

Walking/Working Surface: Any surface, whether horizontal or vertical, on which an employee walks or works, including, but not limited to, floors, roofs, ramps, bridges, runways, form work, and concrete reinforcing steel (but not including ladders, vehicles, or trailers), on which employees must be located in order to perform their job duties.

Webbing: A narrow woven fabric with selvedge edges and continuous filament yarns made from light and heat resistant fibers.

Winch/hoist: A load lifting and/or lowering device that incorporates a winding drum and means for controlling pay-out and take-up of the line from the drum.

Winch/hoist capstan: A load lifting and/or lowering device that incorporates a traction drum and a means for controlling pay-out and take-up of the line from the drum. The device relies on reduction gearing and/or lever principles to achieve a mechanical lifting advantage.

Wire: A single, continuous length of metal with a circular cross-section that is cold-drawn from rod.

End of Section

3. FALL PROTECTION PROGRAM

According to OPNAVINST 5100.23 Series, MCO 5100.29 Series, and NAVMC DIR 5100.8 FP Program Chapter, each Navy and Marine Corps Activity, which has personnel working at heights and exposed to Fall-Hazards, is required to establish and implement a managed Fall Protection program. The managed Fall Protection program shall be in writing, reviewed and approved by the Command Safety Office.

As an alternative to this requirement, a Navy or Marine Corps shore activity, in lieu of a separate written program with safety office review and approval, may state in writing that it is using this *Guide* as its Fall Protection program. DON Activities using the *Guide* as their program shall include site-specific Fall Protection requirements. Navy or Marine Corps Commands/Units being supported by a Regional/Installation Safety Office can be included as part of the Region/Installation Fall Protection program. Coordinate with the Regional/Installation Safety Office to determine the level of support that will be provided.

3.1 COMPONENTS OF A FALL PROTECTION PROGRAM

- a. Activity Policy;
- b. Duties and Responsibilities;
- c. Workplace surveys and Assessment of Fall-Hazards;
- d. Fall-Hazard Prevention and Control, Including the preparation of Site-specific Fall Protection and Prevention Plans;
- e. Training Requirements;
- f. Inspection, Storage, Care, and Maintenance of personal Fall Protection equipment;
- g. Rescue Plan and Procedures;
- h. Fall Mishap Reporting;
- i. Audits and Evaluation.

The following is a Sample Activity Fall Protection Program to assist various Navy and Marine Corps Commands in preparing and establishing site-specific Fall Protection programs and an Audit Checklist for compliance w/OPNAVINST 5100.23 Series, Chapter 13 Fall Protection Program, MCO 5100.29 Series and NAVMC DIR 5100.8, Chapter 18.

August, 2013

3.2 SAMPLE WRITTEN FALL PROTECTION PROGRAM

From: Commanding Officer [NAVY /MARINE CORPS Activity]

To: All [NAVY/MARINE CORPS Activity] Employees

Subj: [NAVY/MARINE CORPS Activity] FALL PROTECTION PROGRAM MEMORANDUM

References:

- (a) OPNAVINST 5100.23 [or MCO 5100.29] Series, Navy [or Marine Corps NAVMC DIR 5100.8] Occupational Safety and Health Program Manual,
- (b) Department of the Navy Fall Protection Guide for Ashore Facilities;
- (c) American National Standards Institute (ANSI) Z359 Fall Protection Code/Standards,
- (d) NAVFACINST 5100.11 Series, Safety and Health Program Manual
- (e) OPNAVINST 5102.1 D/MCO P5102, Navy and Marine Corps Mishap and Safety Investigation, Reporting and Record Keeping,
- (f) USACE EM 385-1-1 Safety and Health Requirements Manual
- (g) 29 CFR 1926.500 Fall Protection in Construction
- (h) 29 CFR 1910, Subpart D, Walking/Working Surfaces
- (i) Any other applicable instructions or manuals

Enclosures:

- (1) Fall-Hazard survey and assessment report (See section 5.3)
- (2) Fall Protection and prevention plan (See section 7.2)
- (3) Fall-arrest rescue plan (See section 10.13)

3.2.1 Purpose

The purpose of this memorandum is to establish a Fall Protection program and provide policy and requirements for the implementation of the program and to establish procedures on Fall Protection and fall prevention for **[NAVY or MARINE CORPS Activity]** personnel working at heights and exposed to Fall-Hazards while conducting maintenance and inspection work.

3.2.2 Applicability

This memorandum applies to **[NAVY or MARINE CORPS Activity]** personnel who are working at heights and exposed to Fall-Hazards while conducting construction, maintenance, or inspection work, and other personnel involved in the Fall Protection program.

3.2.3 Background

August, 2013

Falls from elevation are the leading cause of injuries and fatalities in the work place. Thousands of workers suffer injuries due to falls, resulting in lost time from work. References (a) and (b) direct all Navy and Marine Corps activities to establish a managed Fall Protection program. Additionally, reference (d) directs all NAVFAC Commands to establish Fall Protection programs which include identification and elimination of Fall-Hazards, wherever practical, through engineering controls, training of personnel, proper installation and use of Fall Protection systems, and required rescue equipment and procedures.

The nature of our work requires that **[NAVY or MARINE CORPS Activity]** personnel work at heights and to possibly be exposed to potential Fall-Hazards, or be exposed to falling onto dangerous equipment from any height. Not all **[cranes, buildings, roofs, structures or access to cranes or equipment]** have fully guarded working platforms, guardrails, walkways, or OSHA compliant ladders. Additionally, workers are frequently required to access areas that have unprotected working surfaces. Therefore; alternate Fall Protection methods, including fall-arrest gear, alternate access methods, and restrictions on access are required.

3.2.4 Command Fall Protection Policy

- a. The **[NAVY or MARINE CORPS Activity]** is committed to provide a safe work environment for its personnel exposed to Fall-Hazards, and that the safety of all personnel including military and civilian personnel during performance of their work is of the utmost importance.
- b. **[NAVY or MARINE CORPS Activity]** personnel shall take every reasonable precaution to protect themselves and others during performance of their work.
- [c. As permitted in paragraph 1304, Chapter 13 of reference (a), the **[NAVY or MARINE CORPS Activity]** will use the *Department of the Navy Fall Protection Guide for Ashore Facilities*, reference (b), as its Fall Protection program.]**

3.2.5 Requirements

- a. **[NAVY or MARINE CORPS Activity]** personnel who might be exposed to Fall-Hazards and using Fall Protection equipment shall read and understand the requirements of this memorandum; Chapter 13 of reference (a); and the *Department of the Navy Fall Protection Guide for Ashore Facilities*, reference (b).
- b. **[NAVY or MARINE CORPS Activity]** personnel exposed to Fall-Hazards shall comply with the requirements of reference (b), including being protected from Fall-Hazards when on any elevated walking working surface with unprotected sides, edges, or floor openings, from which there is a possibility of falling four feet or more to a lower level; or where there is a possibility of a fall from any height onto dangerous equipment, into a hazardous environment, or onto an impalement hazard.
- c. **[NAVY or MARINE CORPS Activity]** shall have an assigned Fall Protection Program Manager. Per paragraph 1306.a. of reference (a), a Fall Protection Program Manager is

August, 2013

a person assigned by the command who is responsible for the development and implementation of the Fall Protection program. The **[NAVY or MARINE CORPS Activity's]** Fall Protection Program Manager shall ensure that all personnel exposed to Fall-Hazards, and using fall-arrest equipment and other personnel involved in the program, receive adequate training.

d. Fall-arrest equipment used by **[NAVY or MARINE CORPS Activity]** personnel shall comply with the requirements in paragraph 1309 and appendix 13-B of reference (a), the requirements in reference (b), and with ANSI Z359 Fall Protection Code/Standards requirements, reference (c).

e. **[NAVY or MARINE CORPS Activity]** personnel exposed to Fall-Hazards shall be trained in fall prevention and Fall Protection in accordance to the requirements in paragraph 1310 and appendix 13-A of reference (a), and the training requirements in reference (b). Other personnel involved in Fall Protection program also shall receive Fall Protection training in accordance to the requirements in appendix 12-A of reference (a) and the requirements in references (b) and (c).

f. Anchorages identified and used by **[NAVY or MARINE CORPS Activity]** personnel for fall-arrest equipment shall comply with the requirements in paragraph 1311 of reference (a) and the requirements in reference (b).

g. Inspection, storage, care, and maintenance of **[NAVY or MARINE CORPS Activity]** Fall Protection equipment shall comply with the requirements of paragraph 1312 of reference (a); the requirements in reference (b); and the inspection, storage, care and maintenance instructions by the Fall Protection equipment manufacturers.

h. Falls-from-heights mishaps experienced by **[NAVY or MARINE CORPS Activity]** personnel shall be reported if they meet the reporting criteria of reference (e). When fall-arrest equipment used by **[NAVY or MARINE CORPS Activity]** personnel is deployed or activated during a fall, it shall be reported as a fall-mishap using the Hazard Report in reference (e).

i. Paragraph 1304.d. of reference (a) requires a *“Fall Protection and Prevention Plan”* as part of a managed Fall Protection program when fall-arrest systems are used to provide Fall Protection. For routine and predictable tasks a site-specific *“Fall Protection and Prevention Plan”* shall be prepared and used. For non-routine and emergency tasks, where fall-arrest systems are used, **[NAVY or MARINE CORPS Activity]** personnel may use a generic *“Fall Protection and Prevention Plan”* for the type of **[NAVY or MARINE CORPS Activity]** work **[unprotected side or edge of a building, structure, crane or equipment]** being climbed or accessed at heights (e.g. **equipment on roofs, towers, poles, portal crane, floating crane, overhead traveling crane, mobile crane, etc**). The site-specific and generic plan shall be prepared in advance either by a Competent Person (CP) for Fall Protection or a Qualified Person (QP) for Fall Protection as defined in chapter 1306 of reference (a). For a sample *“Fall Protection and prevention plan”*, see section 7.2.3 of reference (b) and include it as enclosure (1) of the

August, 2013

written Fall Protection program. Paragraph 1307 of reference (a) requires each Navy activity to survey the workplace to identify potential Fall-Hazards and prepare “*Fall-Hazard survey report*”. For sample “*Fall-Hazard survey report*” see section 5.4 of reference (b) and include it as enclosure (2) of the written Fall Protection program. Prior to visiting a site at another Navy Activity, *[NAVFAC Activity]* employees who will be climbing or accessing equipment to conduct inspection, maintenance or repair work at heights shall review the Navy Activity’s “*Fall-Hazard Survey*” for the *[crane/equipment being climbed or roofs and other work areas at heights]*. *[NAVY or MARINE CORPS Activity]* pre-visit letters sent to the activity in advance of scheduled visits is a method that can be used to obtain a copy of the Navy Activity’s “*Fall-Hazard Survey*”. If the “*Fall-Hazard Survey*” or knowledge from previous site visits indicates that there are Fall-Hazards unique to the particular *[crane, equipment, roof, tower etc]* being climbed or accessed (e.g. walkways or platforms without OSHA compliant guardrails, missing swinging gates or chains, OSHA noncompliant step-across opening, etc.); then the generic “*Fall Protection and Prevention Plan*” shall be modified by a Competent Person for Fall Protection for fall protection addressing, eliminating or controlling these specific Fall-Hazards, thus becoming a site-specific “*Fall Protection and Prevention Plan*”.

j. Following a fall from a height, the end-user of Fall Protection, who is wearing a full-body harness that is properly secured to an anchorage, may be suspended in the harness for a length of time, if self-rescue or rescue by co-workers cannot be performed quickly. Sustained immobility in a body harness may lead to suspension trauma also known as harness-induced pathology as described in reference (b). Suspension trauma results from the accumulation of blood in the veins commonly called venous pooling. The symptoms (known as orthostatic intolerance) of suspension trauma include light-headedness, dizziness, weakness, and occasionally, fainting. The reduction in quantity and/or quality (oxygen content) of blood flowing to the brain leads to unconsciousness and harmful effects to other vital organs. If these conditions continue, they potentially may be fatal. *[NAVY or MARINE CORPS Activity]* end-users of Fall Protection shall be trained in the methods for minimizing the effect or delaying suspension trauma if an end-user is suspended in a body harness and unable to perform a self-rescue, and needs to wait to be rescued (e.g., keep legs moving and raise knees into the body to help prevent the pooling of blood in the legs). *[NAVY or MARINE CORPS Activity]* employees shall carry, attached to their full-body harness, two deployable suspension trauma step-in safety straps furnished to them as part of their Fall Protection gear. These safety straps allow employees suspended in a body harness after a fall to insert their feet and stand up to relieve the pressure of harness straps on their thighs, and helps blood circulation until rescued. Note: These straps are safety devices that will help under ideal conditions. They cannot be solely relied upon - there might be a situation where an injury or medical condition occurs before or during the fall, incapacitating the employee suspended in the full body harness, thus not allowing the use of the suspension trauma step-in safety strap.

k. Paragraph 1312 of reference (a) states that “When personal fall-arrest systems are used, the Navy activity must ensure that the mishap victim can self-rescue or can be

August, 2013

rescued promptly should a fall occur.” **[NAVY or MARINE CORPS Activity]** personnel perform work at different Navy activities where the capabilities of the jurisdictional public or Government-emergency response agencies to rescue an employee suspended in a full body harness after a fall vary greatly; therefore prior to visiting a site at a Navy Activity, **[NAVY or MARINE CORPS Activity]** employees who will be using fall-arrest equipment shall review the Navy Activity’s “*Fall-arrest Rescue Plan*” for the site location of the **[crane equipment, tower and other structures]** being climbed. A **[NAVY or MARINE CORPS Activity]** pre-visit letter sent to the activity in advance of a scheduled visit is a method that can be used to obtain a copy of the Navy Activity’s “*Fall-arrest Rescue Plan*”. If the Navy Activity’s “*Rescue Plan*” does not show that the jurisdictional public or Government-emergency response agencies, or an alternative/supplemental rescue method (e.g., a man-lift with a readily available operator) can rescue an employee suspended in a body harness after a fall within 10–15 minutes; then **[NAVY or MARINE CORPS Activity]** employee(s) shall not climb or access that **[crane/equipment/tower/pole]** if climbing or accessing that **[crane/equipment/etc.]** requires the use of fall-arrest equipment. For a sample “*Fall-arrest Rescue Plan*,” see section 10.14, and include it as enclosure (3) to the written Fall Protection program.

[NAVY or MARINE CORPS Activity] Assigned Personnel for the Fall Protection program:

Assigned Fall Protection Program Manager: _____

Designated Competent Person for Fall Protection: _____

(Signature _____)
Commanding Officer

Copy to:

End of Section

August, 2013

3.3 FALL PROTECTION PROGRAM COMPLIANCE CHECKLIST

<p>OPNAVINST 5100.23 Series, CHAPTER 13, OR NAVMC DIR 5100.8, CHAPTER 18 FALL PROTECTION PROGRAM COMPLIANCE CHECK LIST</p> <p>For</p> <p>COMMANDS HAVING PERSONNEL PERFORMING WORK AT HEIGHTS, EXPOSED TO FALL-HAZARDS AND USING FP EQUIPMENT</p>		Date of Audit:		
Unit		Command		
Prepared/Audited by (Signature)		Location		
FALL PROTECTION PROGRAM CRITERIA (Par. 1303/18000)		Yes	No	N/A
1	<p>Does the Command have personnel working at heights, exposed to Fall-Hazards above 4 feet, and using Fall Protection (FP) Equipment?</p> <p>Is there a possibility of a fall from any height onto dangerous equipment, into a hazardous environment, or onto an impalement hazard?</p> <p>Is there any need to deviate from the 4-foot threshold requirement? Is this deviation approved by the designated Competent Person for fall protection?</p> <p>If Yes, a Fall Protection program is required to be established and implemented.</p>			
BASIC PROGRAM REQUIREMENTS (Par. 1304/18003)				
2	Is the Fall Protection program written and approved by the activity safety office?			
3	<p>As an alternate to the written Fall Protection program, is the Activity using the Fall Protection guide as their program with Safety Office review and approval?</p> <p>If using the guide as the Activity Fall Protection program, is the site specific fall protection requirements and information included?</p>			
ADDITIONAL REQUIREMENTS (Par.1305)				
4	Is there a need for the activity to have additional requirements above and beyond the requirements stated in Chapter 13?			
DUTIES AND RESPONSIBILITIES (Par.1306/18002)				
5	Did the Command delineate duties and assigned responsibilities of personnel involved in the Fall Protection program, including Program Manager, Competent			

August, 2013

	and Qualified Persons for Fall Protection, in the implementation of a managed Fall Protection program?			
6	Do the assigned personnel have the necessary skills, knowledge, training and expertise to manage, administer and implement the Fall Protection program safely?			
WORKPLACE SURVEYS AND ASSESSMENT OF FALL-HAZARDS (Par.1307/18002.b.)				
7	Has a survey been conducted for each Fall-Hazard at existing buildings, facilities or structures, and a Fall-Hazard Survey Report prepared?			
8	Was Fall-Hazard analysis performed to determine the risk assessment, hazard severity, and fall mishap probability in accordance w/OPNAVINST 5100.23, Series, Chapter 13?			
9	Is one or more Fall Protection methods identified in the survey report to eliminate or control each Fall-Hazard?			
10	Do the surveyed walking/working surfaces have the structural integrity to support the workers safely (e.g., working on roofs)?			
11	For personnel conducting roof inspections and investigations, have they received proper training to conduct the work safely, prior to accessing the roof? Did the Safety Office approve accessing the roof?			
12	Has the Fall-Hazard survey/assessment been validated annually for comparison purposes?			
FALL PROTECTION AND PREVENTION PLAN (Par. 1304.d/18002)				
13	For personnel exposed to Fall-Hazards and using fall-arrest equipment (not otherwise protected by passive Fall Protection system such as guardrails), has a Site-specific Fall Protection and Prevention Plan been prepared and submitted to the Safety Office for review and approval? (It is recommended to prepare a generic Fall Protection and prevention plan for non-routine tasks [e.g., emergency tasks]). The plan shall be updated as conditions change, once every six months.			
14	Is the Fall Protection and prevention plan prepared either by the designated competent or Qualified Person for Fall Protection? If the plan includes Fall Protection components or systems requiring direction, supervision, design calculations, or drawings by the Qualified Person for Fall Protection, the name, qualifications and responsibilities of the Qualified Person shall be addressed in the plan.			
15	Does the plan describe in detail the specific practices, equipment, methods and procedures to be used for the protection of workers from falling to a lower level,			

and the inspection requirements?				
FALL-HAZARD PREVENTION AND CONTROL (Par.1308/18003)				
PREFERRED ORDER OF CONTROL MEASURES (Par. 1308.a/18003)				
16	Have the Fall-Hazards been evaluated to determine the preferred order of control measures for selecting the appropriate Fall Protection method (i.e. elimination or prevention)?			
17	Can Fall-Hazards be eliminated by alternate work methods or changing task(s) or process(s)?			
SELECTION OF FALL PROTECTION MEASURE (Par. 1308.b18003/)				
18	Is the most appropriate Fall Protection method selected, compatible with the type of work being performed?			
STANDARD TEMPORARY GUARDRAIL SYSTEMS (Par. 1308.b.(1) /18003)				
19	If guardrails are used, do they comply with the specified requirements for height, strength and minimum material of construction?			
20	If perimeter cables are used at unprotected sides or edges, as a method of attaching a lanyard to the cables, do they meet the design requirements for horizontal lifelines? Did the Qualified Person for Fall Protection design the system including anchorages as a horizontal lifeline system?			
COVERS (Par.1308.b.(8) 18003/)				
21	If covers are used to cover a hole 2 inches in its least dimension, are they capable of withstanding without failure, at least twice the combined weight of the worker, equipment and material that will pass over it? When covers are used, are they secured in place and clearly marked or color coded?			
WORK PLATFORMS (Par. 1308.b.(2) /18003)				
22	When working from elevated work platform, is the platform equipped with guardrail or other Fall Protection system? Is the work platform maintained properly?			
SAFETY NET SYSTEM (Par 1308.b.(3)/ 18003)				
23	Does the safety net installation meet the specified criteria and requirements, including the size of the mesh openings and the strength of the outer rope or webbing?			
24	Has the safety net been tested in a suspended position with 400 pounds test weight immediately after installation and under the supervision of a Qualified			

Person?			
25 If a safety net was relocated, repaired or left in place for more than 6 months, was it retested in suspension under the supervision of Qualified Person?			
26 Was the inspection of the safety net performed by a Competent Person and in accordance with manufacturer’s instructions and recommendations?			
27 Inspection of safely nets shall be performed immediately after installation, weekly thereafter, and following any alteration or repair. Has the inspection been documented?			
PERSONAL FALL PROTECTION SYSTEMS [Par. 1308.b.(4) thru (7) /18003]			
28 Do all the fall-arrest systems and equipment used meet ANSI/ASSE Z359 Fall Protection Code/Product Standards?			
29 When selecting personal Fall Protection system, are the free-fall distance, total fall distance, and available clearance taken into consideration?			
30 Do the snaphooks and carabiners used meet ANSI Z359 Fall Protection Code/Standards? (Snaphooks and carabiners meeting ANSI Z359.1-1992(R1999) shall not be used.)			
31 For workers having body weight outside the capacity range of 130-310 lbs and using Fall Protection equipment, is it permitted in writing by the manufacturer?			
32 If it is necessary to increase the free-fall distances beyond 6 feet (i.e. tying at the feet level) and limiting the maximum arresting force on the body under 1,800 lbs, is the Qualified Person for Fall Protection making this determination? There are two types of energy absorbing lanyards, the 6 ft free fall and 12 ft free fall. When the tie off point is located above the dorsal D-ring use the 6 ft free fall energy absorbing lanyard. When the tie-off point is located below the dorsal D-ring, use the 12 ft free-fall energy absorbing single or “Y” lanyards. A Qualified Person for Fall Protection is required to make this determination.			
33 If the sternal D-ring attachment point of the body harness (located at the sternum) is used for fall-arrest, is the worker exposed to a free-fall distance of less than two feet, and the average arrest force on the body less than 900 lbs?			
34 Is the proper Self Retracting Device (SRD) selected and used, taking into consideration the horizontal or vertical application? There are four types of manufactured SRDs, self retracting lanyard (SRL) used only in vertical applications, SRL with leading edge Capability used in vertical and horizontal applications, SRL for rescue and a hybrid component of any two of the above SRDs.			
35 When using “Y” lanyard for 100% tie-off, does the joint between the two legs of			

	the lanyard withstand a force of 5,000 lbs?			
36	The unused leg of the “Y” lanyard shall not be attached to any part of the harness, except to attachment points specifically designated by the manufacturer. Has the manufacturer of the equipment designate such attachment points (Lanyard parking location)?			
37	When using a positioning system, is the worker using a separate system (secondary system) that provides back-up protection from a fall? When using a restraint system, is the lanyard length short enough (or adjustable) to prevent a worker from being exposed to a Fall-Hazard?			
38	When using climbing-ladder FA System for ascending or descending on fixed ladders, is the distance between the connection point of the body harness and the rail or cable 9-12 inches? Will the system stop the fall within two feet from the onset of a fall? Prior to installation, has the ladder (to which the climbing device will be attached), been designed to withstand the forces generated by the fall of the climber?			
FALL-ARREST EQUIPMENT SELECTION CRITERIA (Par. 1309)				
39	Does the selected fall-arrest equipment meet the latest ANSI Z359 Fall Protection Code/Standards? (Any equipment meeting ANSI A10.14 and ANSI Z359.1 1992(R1999) shall not be used)			
40	Can the manufacturer of the selected equipment substantiate thru Third-Party Testing Laboratories, Witness Testing, or Manufacturer Self-Certification Testing, that the equipment meets ANSI Z359 Fall Protection Code/Standards and/or designed, selected and approved by the Qualified Person for Fall Protection?			
TRAINING (Par. 1310/18004)				
41	Is all Fall Protection training for all personnel involved in the Fall Protection program in accordance with the Appendix 13-A and ANSI Z359.2 Standard?			
42	Are workers trained by a Competent Person for Fall Protection who is qualified to deliver the training on the safe use of Fall Protection and rescue equipment, including hands-on and practical demonstrations and in accordance with the requirements in Appendix 13-A?			
43	Did the assigned Competent and Qualified Persons for Fall Protection receive adequate training?			
44	Did other personnel involved in the Fall Protection program receive adequate training?			
45	Has the above training been documented and verified with a certificate of training?			

August, 2013

<p>46 Did end-users receive refresher/update training on the safe use of Fall Protection equipment once every two years?</p> <p>Did the Competent Person for Fall Protection receive refresher/update training to stay current with the Fall Protection and educational requirements once every two years?</p> <p>Did other personnel involved in the Fall Protection program receive recommended or required refresher/update training as specified in Appendix 13-A and ANSI Z359.2 standard?</p>			
<p>SELECTION OF ANCHORAGES FOR FALL-ARREST EQUIPMENT (Par. 1311/18003)</p>			
<p>47 For certified fall arrest anchorages selected/identified and designed by a Qualified Person for Fall Protection, are they capable of supporting at least twice the maximum arresting force?</p> <p>For non certified fall-arrest anchorages selected by a Competent Person for Fall Protection, are they capable of supporting a minimum force of 5,000 pounds per person attached?</p>			
<p>48 For non-certified positioning, climbing ladder fall-arrest system and rescue anchorages selected by a Competent Person for Fall Protection, are they capable of supporting 3,000 pounds per employee attached?</p> <p>For non-certified restraint anchorages selected by a Competent Person for Fall Protection, are they capable of supporting 1,000 pounds per employee attached? For Certified anchorages for positioning, restraint, climbing ladder fall-arrest system, are they selected, identified and designed by a Qualified Person for Fall Protection, meeting the requirement of two times the foreseeable force on the worker?</p> <p>If needed, are certified anchorages for assisted rescue and self rescue designed for 5 times the intended loading by a qualified person?</p>			
<p>49 Are the certified horizontal lifeline anchorages designed by a registered professional engineer with experience in designing HLL systems; or designed by a Qualified Person for Fall Protection who has appropriate training and experience?</p> <p>Non certified anchorages are not permitted for HLL</p>			
<p>RESCUE PLAN AND PROCEDURES (Par. 1312/18002)</p>			
<p>50 For personnel working at heights and using fall-arrest equipment, has a site-specific Fall-hazard rescue plan and procedures been prepared and maintained at the work location?</p>			
<p>51 If self-rescue or assisted-rescue are the planned methods to be used during rescue, did the personnel conducting rescue receive adequate training?</p>			

August, 2013

52	If required, are independent anchorages for rescue identified and selected?			
53	If the method of rescue is by the jurisdictional public and Government-emergency response agencies, has a pre-incident plan been developed?			
INSPECTION OF PERSONAL FALL PROTECTION EQUIPMENT (Par. 1313/18002)				
54	Have procedures been established for inspection, storage care and maintenance of the equipment and in accordance with manufacturer's instructions and recommendations or 3-M maintenance system, whichever is more stringent?			
55	Does the Competent Person for Fall Protection inspect the Fall Protection equipment annually and w/documentation? It is recommended the CP inspect the equipment semi annually.			
56	Does the end-user inspect the equipment prior to each use?			
FALLS FROM HEIGHTS MISHAP REPORTING (Par. 1314/MCO P5102.series)				
57	Are falls-from-heights mishaps reported in accordance with the reporting criteria of OPNAVINST 5102.1D/MCO P5102 (series)?			
EVALUATION OF PROGRAM EFFECTIVENESS (Par. 1315)				
58	Are procedures in place to audit and evaluate the Fall Protection program, at least once every two years?			

End of Section

3.4 Step By Step How to Establish, Manage and Implement a Fall Protection Program

The following is a step by step for establishing managing and implementing a fall protection program arranged in a chronological order:

- 1. Assign Fall Protection Program Manager and designate Competent Person for Fall Protection;**
- 2. Train Fall Protection Program Manager and Competent person for Fall Protection;**
- 3. Program manager develop written FP program;**
- 4. Conduct fall hazard surveys and assessment and develop survey report;**
- 5. Select type of FP systems and FP methods to be used;**
- 6. Develop site specific Fall Protection and Prevention Plan (If PFAS is the planned method). The plan shall be developed either by the Competent Person or Qualified Person for Fall Protection;**
- 7. FP equipment programming and purchases;**
- 8. Identify and train End Users on the use of FP equipment. Training shall be conducted by a competent person;**
- 9. Establish FP equipment storage area and develop requirements for care, maintenance and inspection procedures;**
- 10. Competent person select/identify use of non-certified anchorages. A Qualified Person will design certified anchorages. A Competent person can install, use and inspect certified anchorages under the direction of qualified person;**
- 11. Develop rescue plan and procedures;**
- 12. Conduct refresher/update training as required;**
- 13. Audit the program.**

End of Section

4.0 DUTIES and RESPONSIBILITIES

Navy and Marine Corps Commands shall delineate duties and assign responsibilities to the qualified and trained personnel involved in the development management and implementation of the Fall Protection program. Navy and Marine Corps activities shall ensure that assigned personnel have the necessary skills, knowledge, training and expertise to manage, administer, and implement the Fall Protection program.

4.1 QUALIFIED PERSON (QP) FOR FALL PROTECTION

The duties and responsibilities of the Qualified Person for fall protection include the following:

- Responsible of supporting the Fall Protection program
- Prepare, review, approve, and modify:
 - Fall Protection and Prevention Plans;
 - Fall-Arrest Rescue Plans and procedures;
- Design, select, certify, evaluate, and analyze Fall Protection Systems and Equipment;
- Supervise the design, selection, installation and inspection of certified and non certified anchorages, horizontal lifelines and other engineered systems;
- Involve in the evaluation and determination of fall-arrest system usage when the free-fall distance exceeds 6 feet;
- Review, prepare, and approve Fall Protection Project Specifications;
- Prepare contract documents for Fall Protection systems.
- Knowledgeable with all the Fall Protection standards and regulations;
- The Qualified Person shall also meet the qualification of a Competent Person.

4.2 COMPETENT PERSON FOR FALL PROTECTION

The duties and responsibilities of the Competent Person for fall protection shall include the following:

- Immediate supervision, implementation and monitoring of the Fall Protection program;
- Preparation and Implementation of:
 - Fall Protection and Prevention Plans;
 - Fall-Arrest Rescue plans and procedures;
- Identify Hazardous and Dangerous Conditions in the workplace and to take prompt corrective measures to correct them;
- Conduct Fall-Hazard survey and prepare survey and assessment report;
- Inspection and installation of approved fall-protection systems;
- Compliance with Fall Protection and Prevention Plans and Fall-Arrest Rescue Plans;
- Ensures end-users working at heights and using Fall Protection equipment are adequately trained;
- Supervise the selection, installation and inspection of non-certified anchorages;

August, 2013

- Supervise the installation, use and inspection of certified anchorages, under the direction of the qualified person for fall protection;
- Have knowledge and understanding of Fall Protection systems and equipment;
- Conduct inspection and accident investigations;
- Have full responsibility and authority to implement the Fall Protection and Prevention Plans and Fall-Arrest Rescue Plans and Procedures;
- Knowledgeable with all the Fall Protection regulations and standards;
- Have only one task on-site, which is to monitor employee compliance with Fall Protection and Prevention Plan and Fall-Arrest Rescue Plan requirements.

4.3 FALL PROTECTION PROGRAM MANAGER

The duties and responsibilities of the Program Manager include but not limited to the following:

- Developing and managing the Fall Protection program at the activity;
- Ensures all personnel exposed to Fall-Hazards and using Fall Protection equipment are adequately trained before using the equipment
- Ensures other personnel involved in the Fall Protection program are adequately trained;
- Develop overall Fall Protection training programs;
- Develop and approve equipment purchase list;
- Evaluate Fall Protection program effectiveness.

The Fall Protection Program Manager through training, knowledge and expertise should be able to identify, evaluate and address existing and potential Fall-Hazards.

End of Section

5.0 WORKPLACE SURVEYS AND ASSESSMENT OF FALL-HAZARDS

5.1 FALL-HAZARD SURVEY

Each Navy and Marine Corps activity shall ensure that a survey of the workplace is conducted to identify potential Fall-Hazards per Chapter 5 of OPNAVINST 5100.23 Series or Chapter 1 MCO 5100.29 Series . Navy and Marine Corps activities shall determine whether the walking or working surfaces on which employees are to work have the strength and structural integrity to support the workers safely. Employees shall not be permitted to work on those surfaces until it has been determined that the surfaces have the requisite strength and structural integrity to support the workers and equipment related to their task(s). Once it has been determined that the surface is safe for employees to work on, then it should be determined if a Fall-Hazard exists at the work location.

A Fall-Hazard Survey will help identify potential Fall-Hazards at the workplace. The gathered information will provide documentation to assist in the development of viable solutions to protect personnel exposed to Fall-Hazards. Understanding work procedures and how a person conducts the required task is very important in the selection and development of the most appropriate Fall Protection method. A Fall-hazard survey will help to identify options for fall-hazard elimination and/or selection of other control measures. **The Fall-Hazard survey shall be validated annually for comparison purposes.** The owners of the buildings and facilities are responsible for conducting the fall hazard surveys. The survey information, required for identification of Fall-Hazards at existing buildings or facilities should include:

- a. Interview of workers and their supervisors;
- b. Work-paths and movement of the workers;
- c. Range of mobility in each fall-hazard zone;
- d. Location and Distances to Obstructions;
- e. Potential anchorage Location, if a Fall-Hazard cannot be eliminated or prevented;
- f. Available clearance and total fall distance.
- g. Number of personnel exposed to Fall-Hazards.
- h. Frequency and duration of exposure.
- i. Lock-Out/Tag-Out hazards.
- j. Potential severity of the fall.
- h. Access or egress to fall-hazard area.
- k. Condition of floors and other surfaces.
- l. Review of any fall mishap reports at the facility.
- m. Identify the presence of any:
 - Hot objects, sparks, flames, and heat-producing objects
 - Electrical and chemical hazards
 - Sharp objects
 - Abrasive surfaces
 - Moving equipment and materials
 - Impact of weather factors

August, 2013

- Any other maintenance or work environment issues or conditions

If employees from another activity visit and perform work at the Navy activity where the worksite is located (e.g. Navy or Marine Corps I.G., Audit Teams, Naval Facilities Engineering Command, Navy Crane Center, Inspection Teams, etc.) and encounter Fall-Hazards or potential Fall-Hazards, the visiting team/employee shall be responsible for conducting the subject workplace survey for the specific hazard(s) encountered and provide a report to the Navy or Marine Corps activity Safety Office for the location being visited. The visiting employees shall not perform work at the worksite where there is a fall hazard, unless the hazard has been mitigated, or a Fall Protection solution and/or solution to other encountered hazards, be provided.

In conducting inspection, assessment and investigation work on existing roofs systems or conducting Fall-Hazard surveys, Navy personnel shall perform their work in a safe manner. Navy personnel shall receive the proper training prior to accessing the roof and understand all the required safety precautions and requirements for conducting their work safely. **For roof inspection and investigation work, see Chapter 16 of this Guide.**

5.2 FALL-HAZARD ASSESSMENT

After a Fall-Hazard survey is conducted at a workplace, a hazard analysis can be performed to assess the risk, hazard severity, and fall mishap probability in accordance with the requirements in OPNAVINST.5100.23 series MCO 5100.29 series and NAVMC DIR 5100.8 . This will help in prioritizing of hazard ranking and selection of the most viable Fall Protection solutions.

The primary consideration is to eliminate/remove potential Fall-Hazards from the work place.

5.3 REQUIREMENTS FOR FALL-HAZARD SURVEY REPORT

Instructions for conducting a survey and preparing survey report

- 1. The Survey shall be conducted for each Fall-Hazard to which a person may be exposed.**
- 2. Identify one or more methods to eliminate or control Fall-Hazards.**
- 3. A person who is familiar with building operations and work procedures, and with access to information regarding work processes, environment, policy and best practices should accompany the individual conducting the survey.**
- 4. The survey should include pertinent information as to the type of Fall-Hazard showing basic configuration (graphic/drawings/photos).**
- 5. The report shall identify environmental factors that may affect the building/facility.**

August, 2013

- 6. Establish risk factors to assist in the hazard ranking.**
- 7. Revise the report whenever there is a change in work procedure/task equipment or requirements that will render the previous report obsolete.**
- 8. Interview personnel that will be working at heights and exposed to Fall-Hazards.**

Note: The survey can be conducted by the Program Manager or the Competent Person for Fall Protection. The Competent Person can train and delegate another person to conduct the survey.

For a Sample Survey Report, see paragraph 5.4 or for survey checklist see paragraph 5.5

End of Section

August, 2013

5.4 SAMPLE FALL-HAZARD SURVEY REPORT For Specific Work Location

General information

Activity/Command: _____ Page # _____
Building/Facility # _____ Date: _____
Department: _____
Work Area: _____
Survey Conducted by: _____

Accompanied by: _____

Survey Data

Fall-Hazard Zone and Type (Description): _____

Work Location: _____

Personnel interviewed: _____

Applicable regulations/Standards: _____

Type of work performed: _____

How close is the person to the Fall-Hazard? _____

Location and distance to obstructions: _____

Suggested anchorage location, if Fall-Hazard cannot be eliminated or prevented:

Available clearance and total fall distance: _____

Number of personnel exposed to Fall-Hazard: _____

Frequency and duration of exposure: _____

Exposure rating: High _____ Medium _____ Low _____

Potential severity of a fall: _____

Any obstructions in the potential fall path: _____

Access or egress to Fall-Hazard area: _____

August, 2013

- **Condition of floor or other surfaces:** _____
- **Review any mishap reports at the facility:** _____
- **Any chance of slips trips and same level falls:** Yes ____ No ____
- **Lock-Out/Tag-Out hazard:** _____
- **Floor/surface condition:** _____
- **Identify the presence of:**
 - Hot objects:** _____
 - Sparks:** _____
 - Flames:** _____
 - Heat producing objects:** _____
 - Any electrical/Chemical/RF Transmitter hazards:** _____
 - Sharp objects:** _____
 - Abrasive surfaces:** _____
 - Any moving equipment in the area:** _____
 - Impact of weather factors:** _____
 - Other maintenance work environment/issues:** _____
- **Suggested Fall Protection Solutions:**

Select two of the following probable solutions

- **Guardrails** _____
- **Safety nets** _____
- **Fall-arrest system** _____
- **Travel Restraint system** _____
- **Work positioning system** _____
- **Horizontal lifeline system/Single anchor vertical lifeline** _____
- **Aerial lift equipment/work platforms** _____
- **Warning line system/Designated Area Method** _____
- **Climbing Ladder Fall-Arrest System** _____
- **Raising/lowering devices** _____
- **Covers** _____

If fall-arrest/restraint/work positioning/HLL/Single Anchor VLL system is selected:

- Anchorage(s) location (if any):** _____
- Can rescue be performed if required:** _____
- Type of rescue:** _____
- Any potential swing Fall-Hazards:** _____
- Is the end-user properly trained:** Yes ____ No ____
- Other factors:** _____

August, 2013

- **Fall-Hazard assessment per OPNAVINST 5100.23 Series, chapter 13, or NAVMC DIR 5100.8**
-
-

- **Any additional information:**
-
-

- **Drawings/Sketches/Photos**

- **Prepared by:** _____

- **Approved by:** _____

Note: The above sample survey report is for a single Fall-Hazard location. For a complete survey report at a building, facility, or activity, develop a summary table for all Fall-Hazards and attach the specific survey reports to it.

End of Section

August, 2013

5.5 Site-Specific Fall Survey Report Checklist

<u>GENERAL INFORMATION</u>			
Activity/Command:		Date:	
Building/Facility #:		Work Area:	
Survey Conducted By:		Approved By:	
Fall-Hazard # (1, 2, 3, etc.)	1	FP Program Manager or Competent Person:	
<u>SURVEY INFORMATION</u>			
Major Fall-Hazard Zone or Type:		Work Location:	
Personnel Interviewed:	1.	Guiding Regs:	H
	2.	Work Type:	
	3.		
Distance of Personnel from Fall-Hazard (Ft):		Location or Distance to Obstructions (Ft)?	
Suggested Anchorage(s) (if fall-arrest system utilized):			
Distance to Ground Below (Ft):		Number of Personnel Exposed to Fall-Hazard:	
Frequency/Duration of Fall Exposure:	/	Exposure Risk:	High
Potential Severity of Fall:	Severe Injury	Obstructions in Fall Path:	
Access or Egress to Fall-Hazard Area (i.e. ladder, AWP, Stairs, etc.)	Ladder	Condition of Floor/Other Surfaces:	Good
Historical Fall Mishaps at the Facility?	Unknown	Lock Out/Tag Out Hazard?	No
Is There a Risk of the Following?		Suggested Fall Protection Solutions	
Hot Objects:	<input type="checkbox"/>	Guardrails	
Sparks:	<input type="checkbox"/>	FA Type:	Horizontal Life-Line <input type="checkbox"/>
Flames:	<input type="checkbox"/>		Portable System <input type="checkbox"/>
			Overhead Beam Strap <input type="checkbox"/>
			Self-Retracting Lanyard <input type="checkbox"/>
Energy Absorbing Lanyard <input type="checkbox"/>			
Chemical Hazards:	<input type="checkbox"/>	Maintenance Stand or work platforms	<input type="checkbox"/>
Electrical Hazards:	<input type="checkbox"/>	Restraint System	<input type="checkbox"/>
Sharp Objects:	<input type="checkbox"/>	Positioning System	<input type="checkbox"/>
Abrasive Surfaces:	<input type="checkbox"/>	Aerial Lift/Work Platforms	<input type="checkbox"/>
Weather Factor:	<input type="checkbox"/>	Horizontal or Single Anchor Vertical Lifeline System	
Other risk Factors:	<input type="checkbox"/>	Other FP methods	
Anchorage(s) Locations (if Applicable)			
Can Rescue Be Performed if Required?		Type of Rescue:	Self or Assisted Rescue
Is there a rescue plan prepared?	Unknown	Explain Other:	
Are End-users Trained on Fall-arrest Systems?	Unknown	Do Swing Fall-Hazards Exist?	Unknown
Additional Information			Yes

Note: For complete Fall-Hazard survey of the facility, tabulate and develop summary of findings for all locations.

End of Section

6.0 TRAINING

6.1 TRAINING REQUIREMENTS

- 6.1.1** All Navy and Marine Corps personnel working at heights at shore Facilities, exposed to Fall-Hazards and using Fall Protection equipment, or other personnel involved in the Fall Protection program, shall be trained to recognize the hazards of falling in the workplace and how to minimize such hazards in accordance with the training matrix in paragraph 6.2.
- 6.1.2** Before using Fall Protection equipment, the employee (end-user) must be trained on the safe use of the equipment. It is recommended that all employees (end-users) exposed to Fall-Hazards shall receive a minimum of 16 hours, or as appropriate, Fall Protection training including hands-on training and practical demonstrations. The end-user shall be trained by a person who has the knowledge, expertise and education to deliver the training. Hands-on training and practical demonstrations for the end-user shall be conducted by the Competent Person for Fall Protection.
- 6.1.3** Retraining shall be provided as necessary for employees to maintain an understanding of these subjects.
- 6.1.4** A written certification of training is required and shall be maintained at the job-site for the duration of the work. For those employees visiting from another Navy activity, they (end-users) shall carry the certificates (or pocket cards) with them. The certificate shall identify the name of the employee trained, date of training, and the signature(s) of the trainer(s). Additionally, a determination shall be made as to whether the training has resulted in personnel acquiring the required skills and knowledge.
- 6.1.5** It is highly recommended that a daily "Tool Box" meeting be conducted before work is begun to discuss Fall-Hazards for that day and to remind workers to comply with the established Fall Protection procedures.
- 6.1.6** For Navy or Marine Corps personnel who may be in a situation that requires climbing involving the use of fall-arrest systems, the End-user Training also shall include practice climbing in a controlled situation in the presence of a Competent Person. Additionally, end-users shall be trained in rescue and self-rescue equipment and procedures. A Competent Person who has the knowledge, expertise, qualification and education to deliver the training shall train end-users.
- 6.1.7** All Navy or Marine Corps architects, engineers, and in-house designers involved in planning and designing buildings, facilities, and structures, shall be trained to incorporate Fall Protection and prevention control measures into their designs to help contractors during the construction phase and to provide protection to DON personnel performing their work during normal operation and maintenance phase. The training should emphasize that

August, 2013

Fall-Hazards should be eliminated, and if this not be possible or practical, there must be a mechanism or a control measure in place for preventing or protecting workers from such hazards.

- 6.1.8** All DON Architects, engineers, and other inspectors conducting inspection, investigation and assessment work on existing roof systems shall be trained prior to gaining access to the roof, and to take precautionary measures to protect themselves and other members of the inspection team from Fall-Hazards.

- 6.1.9** In addition to the training requirements in this guide, the training for all personnel involved in the Fall Protection program – Program Manager, Qualified Person, Competent Person, End-user (Authorized Person), Authorized Rescuers, as well as any associated Fall Protection trainers, shall be as prescribed in ANSI/ASSE Z359.2 Standard. All Fall Protection training, including refresher/update training, also shall conform to the requirements of ANSI/ASSE Z490.1-2009 titled “Criteria for Accepted Practices in Safety, Health and Environmental Training.”

- 6.1.10** The following training matrix requirements and methods identify the degree and extent of training for various Navy personnel including refresher/update training:

End of Section

6.2 TRAINING MATRIX

FALL PROTECTION TRAINING REQUIREMENTS AND METHODS

Fall Protection Training Requirements and Methods

Trainee GROUP	Desired Training Objectives	Training Mechanism and Type
End-user/Authorized Person	<ul style="list-style-type: none"> - Selection and safe use of equipment - Application limits - Proper anchoring and tie-off techniques - Estimation of fall distances - Determination of deceleration distance - Total fall distance - Methods of inspection - Storage, care, and maintenance of equipment - Applicable regulations - Limitations of equipment - Specific lifelines - Rescue and self-rescue techniques - Recognize fall-hazard deficiencies - Recognize fall risks at worksite 	<p>Hands-on training and practical demonstrations (a must) for using local equipment or on-site training as applicable to the activity</p> <p>(16 hours or as appropriate)</p>
Construction Management Personnel	<ul style="list-style-type: none"> - Recognize fall-hazard deficiencies - Recognize fall risks at worksite - Basic Fall Protection systems and equipment - Methods of use - Proper anchoring and tie-off techniques - Methods of inspection and record keeping - Storage of the equipment - Applicable regulations - Rescue equipment and procedures 	<p>Fall Protection, part of the 40 hours Construction Safety Training.</p> <p>(Minimum 4 hours)</p>
Contract Management Personnel	<ul style="list-style-type: none"> - Recognize fall-hazard deficiencies - Recognize fall risks at a worksite - Basic systems identification and proper use of equipment. 	<p>(Awareness Training)</p>
Competent Person for Fall Protection (As Designated in writing by the Activity as the Command Competent Person)	<ul style="list-style-type: none"> - In addition to the end-user training, the Competent Person for Fall Protection training shall include hands-on and practical demonstrations, and the following: - Implementation of various Fall Protection systems 	<p>Competent Fall Protection Person As approved by ECHELON II in accordance with OPNAVINST 5100.23 Series and Appendix F</p>

DEPARTMENT OF THE NAVY FALL PROTECTION GUIDE FOR ASHORE FACILITIES

August, 2013

	<ul style="list-style-type: none"> - Proper donning of the equipment - Proper inspection and record keeping - Recognition and identification of Fall-Hazards at work-site - Verification of proper equipment installation techniques - Confirmation of proper anchoring and tie-off techniques - Assessment of risk and hazard ranking - Preparation, updating, review and approval of Fall Protection and prevention plans, and rescue and evacuation plans - Assurance of understanding of Fall Protection regulations and standards by personnel to be exposed to fall hazards - Review and approval of plans and specifications 	<p>of this Guide</p> <p>(Minimum 40 hours)</p>
<p>Qualified Person for Fall Protection</p>	<ul style="list-style-type: none"> - Design, select, analyze, and certify Fall Protection systems and equipment - Prepare, update, review, and approve Fall Protection and prevention plans, and rescue and evacuation plans - Assure understanding of Fall Protection regulations and standards by personnel to be exposed to fall hazards - Review and approve plans and specifications 	<p>(40 hours or as appropriate)</p> <p>As approved by ECHELON II in accordance with OPNAVINST 5100.23,</p>
<p>Architects and Engineers (Designers) involved in planning and design of buildings, facilities and structures</p>	<ul style="list-style-type: none"> - Understand various Fall Protection and prevention planning and design considerations for management of fall-hazards during construction and maintenance phases - Recognize fall-hazard deficiencies - Recognize fall risks assessment and control measures at worksites - Identify basic systems and proper use - Identify and select certified/non certified anchorages - Applicable regulations and standards 	<p>(Awareness Training)</p>
<p>Fall Protection Program Managers (Assigned by the Command)</p>	<ul style="list-style-type: none"> - Recognize and identify Fall-Hazards at workplaces - Understand best practices, criteria and requirements for development and managing Fall Protection program - Risk assessment and hazard ranking 	<p>Course Number CIN A 493 0084 or as approved by ECHELON II</p>

August, 2013

	<ul style="list-style-type: none"> - Understand and identify selection, safe use, and limitation of Fall Protection systems and equipment - Understand proper storage, care, and maintenance of the equipment - Identify applicable Fall Protection regulations - Audit and evaluate program criteria - Understand duties, responsibilities and training requirements for personnel involved in the Fall Protection program 	<p>Minimum 16 hours or as appropriate</p>
<p>Architects, Engineers and other Inspectors conducting Investigation and inspection work on roofs</p>	<ul style="list-style-type: none"> - Receive Fall Protection awareness training - Understand and utilize applicable regulations and standards - Emphasize responsibilities and basic duties of the inspection team - Emphasize safe work practices - Provide for and emphasize safe access - Use protective methods while conducting inspection and investigation work - Implement pre-climbing safety verification checks - Understand and implement procedures for conducting inspections and investigations - Apply training requirements 	<p>(Awareness Training)</p>
<p>End-user/Authorized Person Refresher/Update Training (every 2 years) (Competent Person for FP will determine the extent of the refresher training)</p>	<ul style="list-style-type: none"> Select and use equipment safely - Understand and apply application limits - Employ proper anchor and tie-off techniques - Carefully estimate potential fall distances - Determine deceleration distance - Calculate total fall distance - Understand and apply proper methods of inspection - Apply proper storage, care, and maintenance of the equipment - Implement applicable regulations - Recognize limitations of equipment - Understand the use and limits of specific lifelines - Reinforce understanding of rescue 	<p>(Competent Person determines if Hands-On training and practical demonstrations will be required)</p>

August, 2013

	and self-rescue techniques - Recognize fall-hazard deficiencies-	
Refresher Training for the Competent Person for Fall Protection (Every 2 years)	-Stay current with the Fall Protection and rescue educational requirements -Acquire knowledge and understanding of the best Fall Protection practices and application of fall protection and rescue equipment and systems,	Applicable technical seminars or web based Training

End of Section

6.3 REFRESHER/UPDATE TRAINING

Personnel exposed to Fall-Hazards shall receive refresher/update training on the safe use of Fall Protection equipment and rescue as follows:

- **End-user, Competent Person for Fall Protection and authorized rescuer (Person who conducts rescue) Update/refresher training is required, and shall be conducted at least every two years, to stay current with the Fall Protection and rescue educational requirements in accordance with paragraph 6.2.**
- **Refresher /update training is recommended once a year for the Program Manager/administrator and the Qualified Person for Fall Protection, by accumulating 0.8 International Association for Continuing Education and Training- Approved Continuing Education Units (equivalent to 8 hours).**

6.4 RETRAINING

Retraining in relevant topics shall be provided to the end-user when:

- (1) The end-user has been observed using Fall Protection equipment in an unsafe manner;
- (2) The end-user has been involved in a mishap or a near-miss incident;
- (3) The end-user has received an evaluation that reveals that he or she is not using the Fall Protection equipment properly;
- (4) The end-user is assigned a different type of Fall Protection equipment; and/or
- (5) A condition in the workplace changes in a manner that could affect the safe use of the Fall Protection equipment that the end-user is to utilize.

6.5 AVAILABLE WEB-BASED FALL PROTECTION TRAINING COURSES

The following are the Fall Protection Web-Based training Courses posted on the Navy Enterprise Safety Management System (ESAMS). Marine Corps activities must contact installation safety offices for available training.

Initial Fall Protection Training:

- (1) **End user and Supervisors of End Users Training;**
 - a. **ESAMS Course #2018.**
 - b. **ESAMS Course #3024: Outline for Hands-On Training and Practical Demonstrations requirements for End Users. This course complements course #2018. The training includes**

August, 2013

hands-on and practical demonstrations and shall be delivered by the Competent Person who is qualified to provide the training. The Competent Person for Fall Protection will determine the extent of the hands-on and practical demonstration for the end user which depends on the fall protection equipment and systems used and the work environment.

(2) All personnel

- a. **ESAMS Course #1259 titled Slips Trips and Falls (awareness training).**

(3) Architects/Engineers and other Inspectors conducting roof inspection investigation and assessment work:

- a. **ESAMS Course #3639,**

(4) Fall Protection Program Managers:

- a. **Part 1: ESAMS Course # 4437 titled Fall Protection Program Management;**
- b. **Part 2: ESAMS Course # 4438 titled Fall Protection system and Equipment.**

Web-Based Refresher/Update Fall Protection Training:

(5) Competent Person for Fall Protection: ESAMS Course # 4438.

- (6) End users: take ESAMS Course # 2018 again as refresher/update training. Hands-on training and practical demonstrations per ESAMS course #3024 may be delivered to the end user, per discretion of the Competent Person.**

6.6 FALL PROTECTION TRAINING ROSTER

(1) All employees (workers) newly assigned to a job must review and understand the Fall Protection and Prevention Plan. If the Fall-Hazards, Fall Protection equipment, or methods change during the course of the job, the Fall Protection and Prevention Plan must be reviewed again by all employees working at the job-site. Employees shall be trained in job hazard recognition and shall be trained in the proper use of Fall Protection equipment. Procedures may be developed at the local level to ensure compliance.

(2) All contractor and subcontractor workers exposed to Fall-Hazards shall be trained accordingly by non-Governmental trainers.

(3) If additional requirements arise or change at the job-site as work progresses, the Fall Protection and Prevention Plan and Rescue Plan shall be reviewed and updated by a qualified or Competent Person and signed by all workers exposed to Fall-Hazards.

August, 2013

(4) For those employees visiting from another activity, to perform work at heights and exposed to Fall-Hazards at the Navy activity being visited and before starting work at that site, they shall be trained on the proper use of Fall Protection and rescue equipment.

End of Section

August, 2013

6.7 FALL PROTECTION TRAINING ROSTER (FORM)

All personnel signing this form affirm that they understand the Fall-Hazards on the job-site, and that they have been trained in the proper use of, and will use, the selected Fall Protection equipment and methods. Review and sign again, if hazards or methods or work change.

NAME: _____
ORGANIZATION/CODE/SHOP: _____
TRAINING DATE(s): _____
DURATION OF TRAINING (Hrs): _____
COURSE TITLE: _____
DESCRIPTION OF THE COURSE: _____

NAME: _____
ORGANIZATION/CODE/SHOP: _____
TRAINING DATE(s): _____
DURATION OF TRAINING (Hrs): _____
COURSE TITLE: _____
DESCRIPTION OF THE COURSE: _____

NAME: _____
ORGANIZATION/CODE/SHOP: _____
TRAINING DATE(s): _____
DURATION OF TRAINING (Hrs): _____
COURSE TITLE: _____
DESCRIPTION OF THE COURSE: _____

NAME: _____
ORGANIZATION/CODE/SHOP: _____
TRAINING DATE(s): _____
DURATION OF TRAINING (Hrs): _____
COURSE TITLE: _____
DESCRIPTION OF THE COURSE: _____

INSTRUCTOR'S NAME: _____
INSTRUCTURE'S SIGNATURE: _____

End of Section

7.0 FALL-HAZARD PREVENTION AND CONTROLS

7.1 PREFERRED ORDER OF CONTROL MEASURES

The preferred order of control measures for Fall-Hazards is:

(1) **Elimination** – Removal of the hazard from a workplace. This is the most effective control measure (e.g., lowering various devices or instruments installed at high locations, such as meters or valves, to the height level of the individual; instead of servicing such devices or instruments at heights).

(2) **Prevention** – (traditional) - The isolation or separation of the hazards from the general work areas (e.g., same level barriers such as guardrails, walls, covers or parapets.)

(3) **Engineering Controls** – Where the hazard cannot be eliminated, isolated, or separated, engineering control is the next-preferred measure to control the risk (**e.g., design change or use of various equipment or techniques, such as aerial lift equipment or movable and stationary work platforms**).

(4) **Administrative Controls** – This includes introducing new work practices that reduce the risk of a person's falling (e.g., erecting warning lines or designated areas, restricting access to certain areas, or posting of warning signs).

(5) **Personal Protective Systems and Equipment** – These shall be used after other control measures (such as eliminating or isolating Fall-Hazards) are determined not to be practical, or when secondary systems are needed (e.g., when it is necessary to increase protection by employing a backup system).

NOTE:

Control measures are not mutually exclusive. There may be situations wherein more than one control measure should be used to reduce the risk of a fall.

Navy or Marine Corps activities shall select Fall Protection measures compatible with the type of work being performed. If Fall-Hazards cannot be eliminated, Fall Protection can be provided through the use of Fall Protection systems and equipment and in accordance with chapter 8 of this guide.

7.2 FALL PROTECTION AND PREVENTION PLANS

The Fall Protection and Prevention Plans as required by OPNAVINST 5100.23 Series, MCO 5100.29 Series or NAVMC DIR 5100.8 are documents prepared by Navy or Marine Corps activities for the purpose of planning, designing, installing, monitoring, and rescuing workers exposed to Fall-Hazards; and to prevent fall accidents from occurring in the workplace. The Fall Protection and Prevention Plan is a living document that will require modification due to changes during different phases of work, procedures, methods of construction, or maintenance work. A Qualified or Competent Person for Fall Protection shall be responsible for preparing the Fall Protection and Prevention Plans, as well as making any required changes, designs, updates, or approvals relating to various methods and requirements pertaining to Fall Protection systems and equipment. If the plan includes Fall Protection components or systems requiring direction, supervision, design calculations or drawings by a Qualified Person for Fall Protection, the name, qualifications, and responsibilities of the Qualified Person shall be recorded in the plan. Paragraph 7.2.5 is a checklist that addresses the requirements for occasions where a Competent Person or a Qualified Person for Fall Protection is required to develop Fall Protection and prevention plan.

A Fall Protection and Prevention Plan is equivalent to a permit to work at height; therefore, it is of the utmost importance that a Fall Protection and Prevention Plan be prepared and approved prior to the start of work. The plan shall be kept at the work site at all times, with any changes noted. For those employees visiting from another activity, each of them shall obtain and sign a copy of the Fall Protection and Prevention Plan from the activity being visited. If no Fall Protection and Prevention Plan addressing Fall-Hazards exist at the worksite being visited, then the employee or other team leader shall prepare and sign an addendum to the Navy or Marine Corps activity Fall Protection and Prevention Plan of the person's home activity, which addresses the use of Fall Protection and rescue equipment.

Note: The American National Standards Institute, ANSI Z359.2 (2007) Standard, titled "Minimum Requirements for a Comprehensive Managed Fall Protection Program" identifies the Fall Protection and Prevention Plan as "Written Fall Protection Procedures". According to OPNAVINST 5100.23 Series, preparation of the Fall Protection and Prevention Plan is a requirement as part of the Fall Protection program.

7.2.1 FALL PROTECTION AND PREVENTION PLAN REQUIREMENTS

The Fall Protection and Prevention Plan is different from the Fall Protection Plan required per 29 CFR 1926.502(k). A Fall Protection Plan as required by OSHA is available only to employees, performing construction work, who can demonstrate that it is infeasible, or it creates greater hazard, to use conventional Fall Protection systems: (i.e., guardrails, safety nets, or personal fall-arrest systems). The Fall Protection and Prevention Plan is a document that includes written procedures for performing a specific work, task, or project, indicating the proper way of using safe Fall Protection systems and equipment, and including any other relevant information; however, it is a requirement to develop a Fall Protection and prevention plan for routine and non-routine tasks.

The Fall Protection and Prevention Plan shall include the following:

- a. Description of Fall-Hazards that will be encountered at the workplace by end users during performance of their work.
- b. Type of Fall Protection/fall prevention methods or systems used for every phase of work.
- c. Training requirements for every employee exposed to Fall-Hazards.
- d. Type of Fall Protection equipment and systems provided to the employees that might be exposed to Fall-Hazards.
- e. The names of qualified and Competent Persons included in the plan.
- f. The Fall Protection equipment and instructions for assembly, disassembly, storage maintenance, and care.
- g. A Fall Protection and Prevention Plan is prepared either by a Competent or Qualified Person for fall protection. A Competent Person will implement the plan. All employees working at heights and using personal fall protection equipment at a job-site shall understand and agree to use the Fall Protection and Prevention Plan.
- h. The rescue plan and procedures.

Note: for sample written FP and Prevention Plan, see paragraph 7.2.3 or the checklist in paragraph 7.2.4.

7.2.2 INSTRUCTIONS FOR PREPARING THE PLAN

- a. The plan shall be prepared specifically for the workplace and the specific task (site specific).
- b. The plan shall provide for 100% continuous Fall Protection.
- c. The plan shall include training requirements and qualifications of the end-user permitted to use the system.
- d. The plan shall include the following:
 - Identification of acceptable anchorages;
 - Anchorages selected or designed by Qualified Person for Fall Protection or Competent Person for Fall Protection (Certified or Non-Certified anchorages);
 - Complete setup procedure(s) for access;
 - Clearance requirements for free-fall distances and for total fall distances including available clearance;
 - Detailed instructions for assembling, use and dismantling of the system(s), including descriptions of all the components
 - Number of personnel using the system;
 - Any limitations of the system;

August, 2013

- Applicable manufacturers' standards and drawings;
- Detailed instructions for inspecting each component of the system, and intervals of inspection;
- Any other pertinent information.

End of Section

August, 2013

7.2.3 SAMPLE FALL PROTECTION AND PREVENTION PLAN (FORM)

Activity/Command: _____

Building/Facility # _____

Department: _____

Work Area/Location: _____

Plan Prepared by: _____

Date Prepared on: _____

Date Modified: _____

Plan implemented by: _____

Task/Work Description:

Name of personnel exposed to Fall-Hazards: _____

Description of the Fall Protection system to be used: _____

Training Requirements: _____

Anchorage Location and type: _____

Anchorage Strength: _____

Certified/Non-Certified Anchorage: _____

Describe the rest of the system used: _____

Describe the set up procedure for access to work location:

Instructions for:

Assembly: _____

Use: _____

Disassembly: _____

Inspection Care and Maintenance: _____

Available clearance: _____

Free-fall Distance: _____

Total Fall Distance: _____

Number of personnel using the system: _____

System Limitation: _____

Equipment Inspection Procedure and Intervals: _____

Design of the system (if required):

August, 2013

Manufacturer's standards/drawings including instructions and recommendations:

Any other info: _____

Include rescue plan and procedures _____

Prepared by: _____

Approved by: _____

End of Section

August, 2013

7.2.4 Site-specific Fall Protection and Prevention Plan Checklist

<i>GENERAL INFORMATION</i>			
Activity/Command:		Date:	
Facility/Building #:		Phone:	
Detailed Location:		Plan Prepared By:	
Dates(s) Plan was Modified:	1.	This Revision of Plan Implemented on (Date):	1.
	2.		2.
	3.		3.
Task/Work Description:			
Name(s) of Personnel Exposed to Fall-Hazards and using Personal Fall Protection Equipment:	1.	6.	
	2.	7.	
	3.	8.	
	4.	9.	
	5.	10.	
<i>Personal Fall Protection System</i>			
Description of the Fall Protection System to Be Used:		Identification or Selection of Anchorage(s) and Types:	
Anchorage Location:		Anchorage Strength:	
Certified Anchorages designed by QP		Required Strength	
Free-fall distance		Total fall Distance	
Required Clearance		Available Clearance	
Design of FA System (If required)		Personal Fall Protection System Limitations	
<i>TRAINING</i>			
Competent Person and/or Qualified Person training Completed:		End-user(s) Training Completed:	
Program Manager Training Completed			
<i>OTHER INFORMATION</i>			
Include Manufacturer's Instructions and Recommendations for Use, Assembly, Disassembly and Inspection Criteria			
Additional Instructions:			

August, 2013

7.2.5 WHEN A COMPETENT OR QUALIFIED PERSON IS REQUIRED TO DEVELOP FALL PROTECTION AND PREVENTION PLAN

COMPETENT OR QUALIFIED PERSON CHECKLIST			
Navy or Marine Corps Command:	Location		
FP Program Manager:	Date:		
COMPETENT PERSON INFORMATION			
Competent Persons Name: _____ Length of experience in this occupation: _____			
TRAINING KNOWLEDGE AND EXPERIENCE			
	Yes	No	N/A
Does the designated individual have training knowledge and experience in:			
• Applicable Fall Protection regulations, standards and requirements?			
• Fall-Hazard recognition (How to recognize and identify Fall-Hazards)?			
• Duties and responsibilities of other designated personnel under the FP Program (e.g. Qualified Person, end-user, authorized rescuer, etc.)?			
• Conducting Fall-Hazard surveys and preparing survey report?			
• The requirements and criteria for guardrails, safety nets, scaffolds, aerial lifts and movable and stationary work platforms, warning line system/designated area method, and safety monitoring system?			

August, 2013

<ul style="list-style-type: none"> • Developing Fall Protection and prevention plans (written Fall Protection procedures)? <p style="text-align: center;">Notes:</p> <ol style="list-style-type: none"> 1. If the Fall Protection and Prevention plan includes Fall Protection components or systems requiring direction, supervision, design calculations or drawings by a Qualified Person for Fall Protection or a professional engineer, the name, qualifications, responsibilities, training knowledge, experience and signature of the Qualified Person for Fall Protection or professional engineer shall also be addressed in the plan. 2. At a minimum, the Qualified Person/professional engineer information is required when using Horizontal Lifelines, Other Engineered Systems, the anchorages or tie-off points are located below the dorsal D–ring and designing certified anchorages that require being twice the maximum arrest or potential force. 			
<ul style="list-style-type: none"> • Fall-arrest, positioning, restraint and climbing ladder fall arrest systems 			
<ul style="list-style-type: none"> • Fall-Hazard elimination and control methods including hands-on how to assemble, disassemble and use Fall Protection systems and equipment (Donning of the equipment, equipment installation techniques and proper anchoring and tie-off techniques)? 			
<ul style="list-style-type: none"> • Fall Protection system and equipment assessments (e.g. component compatibility, estimating free-fall distances, total fall distance and required clearance, and common hazards of each system and component used) and determining when a system is unsafe? 			
<ul style="list-style-type: none"> • How to conduct detailed inspection storage care and maintenance of equipment, components and systems with documentation? 			
<ul style="list-style-type: none"> • Fall Protection rescue equipment and procedures and prepare Fall-Hazard rescue plan? 			
<ul style="list-style-type: none"> • The selection and use of non-certified anchorages (e.g. 5,000 lbs anchorage for FA)? 			
<ul style="list-style-type: none"> • Requirements for working over or near water or working from/in machinery over water 			
<p>List training/experience including certificate of training;</p>			

August, 2013

AUTHORITY	Yes	No	N/A
Does the designated individual have authority from the Command to: <ul style="list-style-type: none"> • Take prompt corrective action to eliminate existing and predictable fall hazards? • Stop work? 			

Use of this checklist is optional.

End of Section

8.0 FALL PROTECTION SYSTEMS, CRITERIA, AND DESIGN REQUIREMENTS

System Selection

It is very important for a Qualified or Competent Person for Fall Protection to plan, evaluate, design, and select the most appropriate, safe, and efficient Fall Protection system. There are many Fall Protection systems available which can be used. It is of the utmost importance to select the right system for a specific work application. A complete understanding of work procedures will enable the Qualified Person for Fall Protection or Competent Person for Fall Protection to select the most appropriate Fall Protection system.

Redundant (Secondary) System

In every fall-hazard situation, it is always advisable to have two protective systems: primary, and secondary as back-up. If the primary system fails, the secondary system shall protect the employee from falling. For example, when approaching an unprotected side or edge of a roof, the employee's primary protective system is his/her feet. A secondary protective system is required as backup, such as a fall-arrest/restraint system, or guardrails. When climbing a fixed ladder or a pole, the employee's primary fall protective system is his/her hands and feet. A climbing ladder FA system or a self-retracting lanyard is required as a secondary backup system. Always plan to have two Fall Protection systems; primary, and secondary.

8.1 FALL PROTECTION SYSTEMS

Every employee on a walking working surface exposed to a Fall-Hazard shall be protected from falling to a lower level by the use of a Fall Protection system. The common Fall Protection systems are:

- ◆ **Prevention Systems**
 - **Guardrail Systems**
 - **Covers**
 - **Work-stands/Stationary Work Platforms and Catwalks**
- ◆ **Safety Nets**
- ◆ **Fall-arrest System**
- ◆ **Other Fall Protection Systems include:**
 - **Horizontal Lifeline**
 - **Single Anchor Vertical Lifeline**

August, 2013

- **Climbing Ladder Fall Arrest System (Ladder climbing device)**
- **Positioning System**
- **Restraint Systems**
- **Rope Access**
- **Aerial Lifting Equipment,**
- **Movable Working Platforms, or Scaffolds (e.g. AWP, work stands or Scissor Lifts)**
- **Warning Systems**
- **Designated area method**
- **Monitoring System**
- **Controlled Access Zone**
- **Other Engineered Fall Protection Systems**

8.2 FALL PROTECTION SYSTEMS CRITERIA & REQUIREMENTS

8.2.1 PREVENTION SYSTEMS (Passive Fall Protection Systems)

8.2.1.1 GUARDRAIL SYSTEM

Guardrail System is a conventional method for the prevention of falls from heights which is installed at all open sided floors, openings and platforms where a person is required to walk or work. Guardrails can be temporary or permanent.

Open sided floor or edge mean any side or edge (except at entrances to points of access of floors, roofs, working platforms, stairs, catwalks, scaffolds, and ramps or runways) where there is no wall or guardrail system.

Guardrail consists of top-rail, mid-rail, posts (stanchions) and toe-board.

Note 1: Requirements for permanent guardrail systems installed in buildings is prescribed in the International Building Code (IBC) using the term “Guards” instead of guardrails. Permanent Guard requirements for height and strength are identical to guardrails prescribed by OSHA.

Note 2:

Guardrails shall be so surfaced as to prevent injury from punctures or lacerations, and to prevent snagging of clothing.

8.2.1.1.1 Criteria:

August, 2013

- **Top-rail** shall be 42 inches high, plus or minus 3 inches above walking/working level. (39-45 inches high).
- **Mid-rail** shall be located half way between the top edge of the guardrail system and the walking working surface, but never more than a 19 inch gap between the mid-rail and the top of the rail, or between mid-rail and the walking working surface. Screens, mesh, intermediate vertical members or equivalent intermediate structural members can replace the mid-rail. The vertical opening shall not be greater than 19 inches.
- **Posts** shall be spaced no more than 8 feet apart on centers.
- **Toeboard** shall be minimum 3½ inches high. Per 29 CFR 1910, the toe-board height is 4 inches

8.2.1.1.2 Material of Construction.

(a) Wood Construction:

Wood components shall be of construction grade lumber or better (minimum 1,500 lb-ft/square inch fiber stress);

- Top rail and Posts shall be minimum nominal 2X4 lumber;
- Mid rail shall be made a minimum nominal 1X6 lumber;
- Toe-board shall be made a minimum nominal 1X4 lumber.



(b) Structural Steel:

Posts, top-rail and mid-rail shall be at least 2-inches X 2-inches X 3/8 inch structural steel angles.

(c) Pipe Railing

Posts, top rail and mid rail shall be at least 1-1/2 inches nominal diameter (schedule 40 pipe).

August, 2013



Removable Railing



Collapsible Railing

(d) Steel Cable

Top-rail and mid-rail shall be at least ¼ inch steel cable flagged every 6 feet with high visibility material. There shall not be more than a 3 inches sag in the steel cable.



(e) Chains

Steel chains for top-rail and mid-rail, all components shall have the same criteria for guardrail system above. There shall not be more than a 3 inches of sag in the chain. Guardrails or stair-rails shall be so surfaced as to prevent injury from punctures or lacerations, and to prevent snagging of clothing.

August, 2013

Note: During hoisting operations If a segment or side of the railing system is required to be left open for easy access at an unprotected side, edge, hatch, etc, use self-closing swing gates, chain, removable guardrail section or fall arrest/restraint system will be required to protect personnel from falling.

8.2.1.1.3 Strength Requirements.

The following limits the *minimum* forces the temporary guardrail system members shall withstand without failure when applied within 2 inches from the top edge in any outward or downward direction:

- Top-rails ----- 200 pounds
- Mid-rail ----- 150 pounds
- Toe-board ----- 50 pounds
- When a 200-pound force is applied at the top edge of the top-rail in a downward direction, it shall not deflect more than 3 inches.

Any screen, mesh, intermediate vertical member, solid panel, and any equivalent structural member shall withstand a force of 150 pounds.

8.2.1.1.4 Stair-Rails and Handrails:

- (a) Permanent handrails shall be mounted 34 to 38 inches high to the top of the rail.
- (b) For temporary handrails (during construction) the height may be 30 inches to 37 inches.
- (c) Permanent Stair Rails shall be 42 inches high. (During construction, temporary stair-rails may be 36 to 37 inches high.

- Permanent Stair Rail: 42 inches high
- Permanent Hand Rail: 34-38 inches high

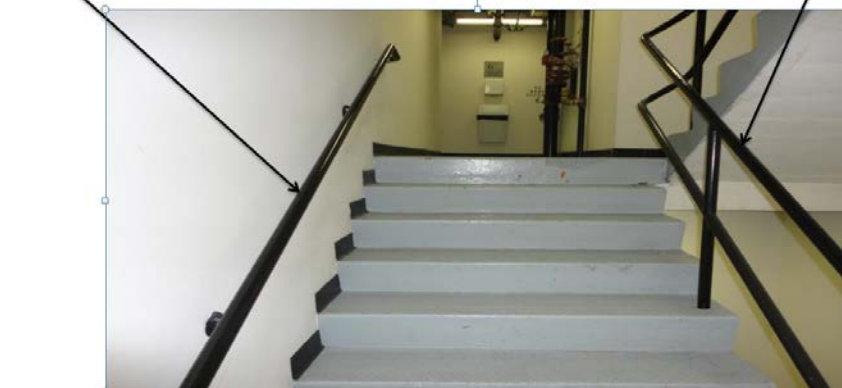

August, 2013

8.2.1.1.5 Parapets:

For existing parapet walls with heights of less than 42 inches, the parapet wall may be used as a Fall Protection system if the vertical height is a minimum of 30 inches and the width a minimum of 18 inches at the top of the wall for a total of 48 inches combined. The effective height of a parapet wall is the sum of the height of the wall plus the wall width at the top of the wall. New parapet walls shall be designed to a height of 42 inches (± 3 inches), to be considered adequate Fall Protection systems.

The height of the existing 30-inch high parapets shall not be increased to comply with the guard rail height requirement of 42 inches ± 3 inches, without involving the structural engineer. Increasing the height of the parapet increases the exposure to wind. Since the parapet resists wind by acting as a cantilever, the stresses at the base of the parapet (The level of the roof structure) are proportional to the square of the parapet height. For example, adding an extra foot to the existing 2 foot high parapet roughly doubles the wind stresses at the base. Recommend using either steel cable or railing to make the parapet 42 inches high (± 3 inches).

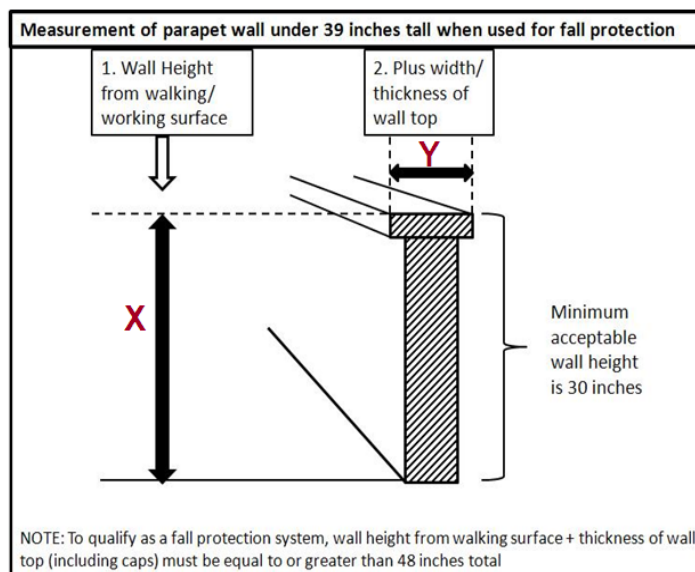

8.2.1.2 COVERS

- Install a cover on any hole, 2 inches or more in its least dimension.
- All covers shall be capable of supporting, without failure, at least twice the weight of the employees, equipment and materials that may be imposed on the cover at any time.
- Covers shall be secured in place when installed.



OSHA Compliant Cover

8.2.1.3 WORK-STANDS, STATIONARY WORK PLATFORMS AND CATWALKS

- Work-stands, stationary work platforms, and catwalks shall be equipped with guardrails or other Fall Protection system(s). For safer work-stands, provide a swing gate at the platform level near the stairs to prevent a worker from unintentionally moving backward and falling down the stairs.



Work Stand

8.2.2 SAFETY NETS

Safety nets are installed as close as practical below the leading edge for employee protection or when working over water, on bridges, or high-rise buildings or structures.

- (1) The minimum breaking strength of border rope or webbing shall be 5,000 pounds.
- (2) The mesh opening shall not be larger than 36 square inches or longer than 6 inches on any side.
- (3) In any case, the net shall be installed not lower than 25 feet from the working surface.
- (4) Safety nets shall extend out from the working surface as follows:

Distance from working level to the net	Distance the net shall extend from working surface
Up to 5 feet	8 feet
Over 5 feet up to 10 feet	10 feet
Over 10 feet	13 feet

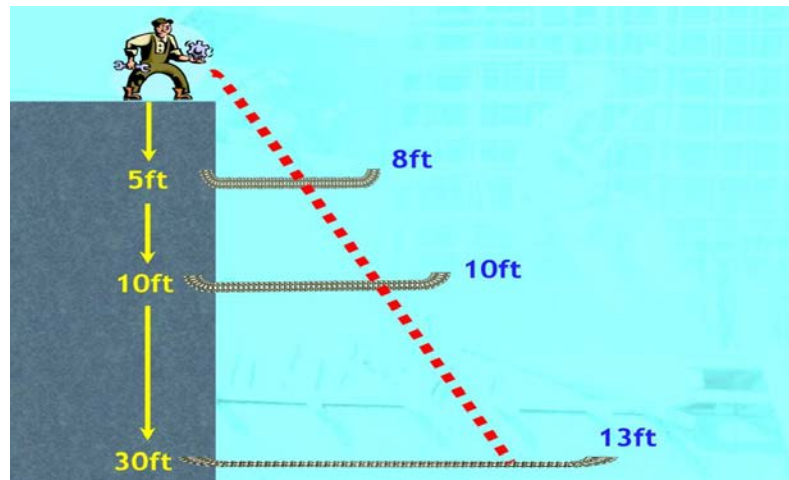

- (5) Safety nets shall be tested in suspension position in the field and certified by a Qualified Person immediately after installation and at six month intervals using a drop test of 400 pounds, dropped from the same elevation a worker might fall.
- (6) Inspect safety nets immediately after installation, weekly thereafter, and following any alteration or repairs. Inspection must be documented.
- (7) Shackles and hooks used for safety net installations shall be made of forged steel.

August, 2013

- (8) Immediately remove any debris that falls into the net.

8.2.3 FALL-ARREST SYSTEM (ACTIVE FP SYSTEM)

Fall-arrest System consists of the following subsystems and components:

- **Anchorage System** – Consists of anchorage and anchorage connector.
- **Connecting Means** – Includes energy absorbing lanyard with snaphook or carabiner at each end or self-retracting device. The subsystem may also include fall-arrester.
- **Body Support** – Consists of full-body harness with integral dorsal D-ring.
- **Rescue procedures** – Consist of self-rescue or assisted rescue.

Notes:

- i. Fall-arrest is considered an active Fall Protection system. The system will become activated when a fall is initiated. Fall-arrest system is also considered a secondary system.
- ii. Whenever possible, employees should work in pairs (buddy system). At the minimum, there must be an assigned safety person (spotter) when there is an employee or employees climbing and performing work at heights and using fall-arrest equipment.
- iii. Personal fall arrest systems (PFAS) are typically certified and labeled only within the capacity range of 130 to 310 pounds (59 to 140.6 kg) including the weight of the worker, equipment, clothing and tools. Workers shall not be permitted to exceed the 310-pound weight limit, unless the harness and the lanyard are specified in writing by the manufacturer. For workers with body weight less than 130 pounds, a specially designed harness and a specially designed energy absorbing lanyard which will properly deploy if this person were to fall, shall be utilized.

Note: It is highly recommended for overweight workers, weighing over 310 pounds, to consult a physician prior to use of the equipment to determine that he or she has no medical conditions (e.g., hypertension, diabetes, coronary heart condition, etc). Heavy workers are usually in a high-risk category for health and occupational injuries. While personal protective equipment may have the strength to stop the worker from contacting a lower level or object during a fall, typically the fall forces imposed on the body of heavy workers will be higher than those of the average-weight worker; requiring the need to review and evaluate the fall-arrest system used, as well as the worker's medical condition(s). The following are some questions for consideration by the Qualified Person

August, 2013

or the Competent Person for Fall Protection before selection and use of the equipment by overweight workers:

- **Can the structure or the anchorage support the potential fall forces?**
- **Can the free-fall distance be minimized during a fall? (The ability to adjust the energy absorbing lanyard's length or raising the anchorage location will minimize the free-fall distance.)**
- **Is the lanyard or lifeline rated for higher capacity?**
- **Is the full-body harness rated for higher capacity?**
- **Is the rescue plan adequate to accommodate heavy-weight workers? The rescue equipment for heavy workers may need to be more robust, or other methods for rescue may need to be planned.**



8.2.3.1 FALL-ARREST SYSTEM REQUIREMENTS

OSHA Requirements

- (1) The system must limit the maximum arrest force on the worker's body to 1800 pounds, when wearing a full-body harness.
- (2) Maximum free-fall distance shall be 6 feet.
- (3) The system shall stop the fall within a deceleration distance of not more than 42 inches.

August, 2013

(4) The system shall prevent the worker from contacting a lower level or object.

Note 1: ANSI/ASSE Z359 Fall Protection Code/Standards. Permits the use of a sternal D-ring attachment point (located in the front at the sternum), to be used for limited fall-arrest (e.g. used with climbing-ladder FA system), as long as the free-fall distance shall not exceed 2 feet, and the maximum arrest force on the body does not exceed 900 pounds.

Note 2: OSHA Standards and the New ANSI Z359 FP Code/Standards permit the free-fall distance to exceed 6 feet and up to 12 feet, provided the maximum arrest force on the body does not exceed 1,800 pounds. Only the Qualified Person for Fall Protection can make this determination (increasing the free-fall distances to more than 6 feet and using 12 ft free-fall energy absorbing lanyard).

8.2.3.2 FALL-ARREST SUBSYSTEM AND COMPONENTS

All personal fall-arrest equipment used shall meet the requirements of ANSI Z359 Fall Protection Code/Standards. Any equipment meeting ANSI A10.14 or ANSI Z359.1 (1992 Revised 1999) shall not be used and shall be removed from service.

(I) Anchorage System for Fall-arrest:

(a) **Anchorage** is the any rigid part of a building or structure such as beam, column, floor or equipment and shall withstand a minimum force (breaking strength) of 5,000 pounds, or engineered for twice the maximum arresting force by the Qualified Person for Fall Protection.

(b) **Anchorage Connector** is intended for attaching personal fall-arrest system to the anchorage, shall meet the requirements of the anchorage and withstand a force of 5,000 pounds.

Note 1: Some manufacturers require 5,400 pounds minimum anchorage connector strength for their equipment.

Note 2: always consider the compatibility between the anchorage and anchorage connector to prevent unintentional disengagement...

August, 2013



Anchorage Connectors

(II) Connecting Means

(a) Snaphooks and Carabiners:

- (1) Shall have a minimum strength of 5,000 pounds.
- (2) The gate must withstand a minimum force of 3,600 pounds when applied in any direction, and shall meet the requirement of ANSI Z359 FP code/Standards. Few snap-hooks or carabiners have gate strength of 5,000 pounds (end-users shall be trained to recognize this type of equipment).

Snaphooks and carabiners having side loading gate strength of 350 pounds, (Manufactured per ANSI Z359.1 (1992, R1999)) shall not be used.

- (3) Snaphooks and carabiners shall be sized to be compatible with the connectors to which they are connected. Compatible connections will prevent unintentional disengagement.
- (4) Snaphooks and carabiners shall be self-closing and self-locking, capable of being opened by at least two consecutive deliberate actions. The non-locking types are prohibited.

Compliant snaphooks and carabiners shall be engraved with the words “3,600 lbs”, denoting the gate strength.

August, 2013



Snaphook

Carabiner

b) Energy Absorbing Lanyards:

- (1) Energy Absorbing Lanyards used in fall-arrest systems vary in length from 2 to 6 feet, depending upon the application. The length of the lanyard used in fall-arrest shall not exceed 6 feet.
- (2) The strength of the lanyard and the energy absorber shall be 5,000 pounds, minimum.
- (3) The minimum diameter of a synthetic rope lanyard is 1/2 inch.
- (4) Provide energy absorbers (shock absorbers) with lanyards (integral in-line is preferred).
- (5) There are two types of single and “Y” energy absorbing lanyards:

(i) Six foot Free-fall Energy Absorbing Lanyard:

The 6-foot Free-fall (FF) energy absorbing lanyard shall be used only when the tie-off point is located above the dorsal D-ring, creating a FF distance of less than 6 feet. The average arresting force on the body shall not exceed 900 lbs (4 kN) under ambient dry conditions, and 1,125 pounds under ambient wet conditions. The maximum deployment distance of the energy absorber shall be 4 feet, which is greater than the OSHA requirement of 3½ feet.

August, 2013



Six foot free fall energy absorbing lanyard

(ii) 12-foot Free-fall Energy Absorbing Lanyard:

When an anchor point is below the dorsal D-ring, a free-fall (FF) distance greater than 6 feet is created. For these situations, a 12-foot FF energy-absorbing lanyard shall be used in accordance with manufacturer's instructions and recommendations. The average arresting force on the body shall not exceed 1,350 lbs (6 kN) under ambient dry conditions, and 1,575 pounds under wet conditions. The maximum deployment distance of the energy absorber shall be 5 feet. The 12-foot FF energy absorbing lanyard shall be used when the tie-off point is below the dorsal D-ring.

NOTE (1): A 12-foot FF energy-absorbing lanyard does not refer to the lanyard length. Instead it refers to a free-fall that is greater than 6 feet (up to 12 feet), which is created by the anchor point's being located below the dorsal D-ring. The maximum lanyard length shall not exceed 6 feet. (Personnel whose body weight and equipment exceed 310 lbs shall not be permitted to use the 12-foot FF energy absorbing lanyard; always refer to equipment labels and manufacturer's instructions, restrictions and recommendations).

Note (2): The deployment distance for the 6-foot FF and 12-foot FF energy absorbers is very critical when calculating the required clearance for the fall-arrest system.

(6) When using the 6-foot or 12-foot FF "Y" lanyards:

Warning: Do not attach the unused leg of the "Y" lanyard to any part of the harness except to attachment points specifically designated by the manufacturer; especially the "Y" lanyard having a single common energy absorber. The joint between the two legs shall be designed for 5,000 pounds. It is highly recommended to use a "Y" lanyard having legs that expand and contract

August, 2013

(Retractable). When traversing, do not connect to anchorages that are farther away than the lanyard length, and do not allow the legs of the lanyard to pass under arms, between the legs, or around the neck of the end-user. Do not use a 6-foot FF energy-absorbing “Y” lanyard if the free-fall (FF) distance is greater than 6 feet.

- (7) A lanyard strap shall not be wrapped around a tie-off point and then attached back to it-self; unless it is a tieback lanyard where the lanyard straps have been designed accordingly.
- (8) The snap-hook shall be secured only to an integral D-ring (incorporated into the body harness by the manufacturer).
- (9) All equipment shall have permanently attached labels indicating the manufacturer’s name, serial number or lot number, date of manufacture, capacity, and that applicable OSHA and ANSI Z359 Fall Protection Code/Standards have been met. The label of 6 ft FF EA lanyard shall have white background with black lettering and the 12 ft FF EA lanyard shall have black background with white lettering.

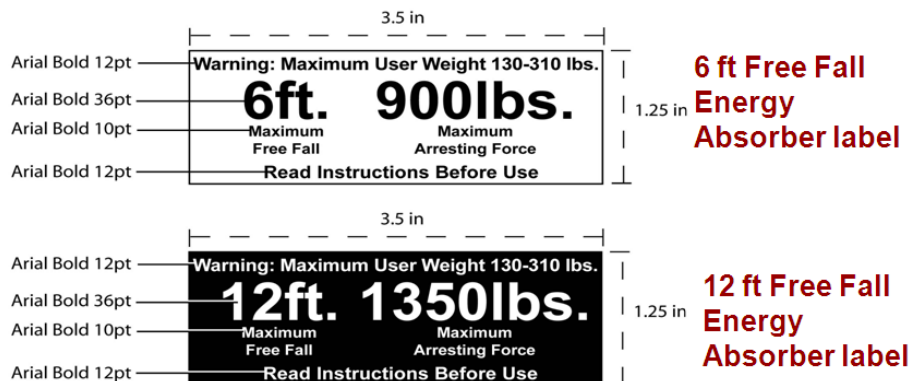

- (10) It shall be recognized that synthetic rope and nylon strap lanyards are more elastic than Kevlar or wire rope lanyards.
- (11) Energy absorbers shall have permanently attached labels indicating the manufacturer’s name, serial number or lot number, date of manufacture, maximum elongation force, maximum free-fall (FF) distance, capacity, and that it meets OSHA and ANSI Z359 Fall Protection Codes/standards. The label for the 6-foot FF energy absorber shall have black lettering with white background. The 12-foot FF energy absorber label shall have white lettering with black background.

Note: All single and “Y” lanyards shall be equipped with deployment indicators.



“Y” Lanyard

(c) Self-retracting Devices (SRDs)

SRDs are deceleration devices made of synthetic rope, webbing or wire rope. There are four types of SRDs:

- (1) Self-retracting Lanyard (SRL);
- (2) Self-retracting lanyard with Leading Edge Capability (SRL-LE);
- (3) Self-retracting Lanyard with Rescue Capability (SRL-R)
- (4) A hybrid combination of any two of the above.

Note: Newly purchased Self-retracting Devices shall be equipped with a visual indicator, which shall be readily visible.

(c.1) Self-Retracting Lanyards (SRL):

Requirements

The maximum arrest distance shall not exceed 2 feet.

- (1) The average arrest force on the body shall not exceed 1,350 pounds.
- (2) The maximum peak force shall not exceed 1,800 pounds.
- (3) SRL shall be used only in vertical applications (Use for fall-arrest and where the tie-off point is located above the dorsal D-ring).
- (4) The activation force required to deploy the energy absorber shall be less than 450 pounds.

August, 2013



Self Retracting Lanyard

(c.2) Self-retracting Lanyards with Leading Edge Capability (SRL-LE)

Requirements:

- (1) Maximum arrest distance of 4.5 feet;
- (2) Free-fall distance of 5 feet;
- (3) Average arrest force on the body of 900 pounds;
- (4) Equipped with energy absorber which is a pouch made of stitched fabric;
- (5) Used in vertical and horizontal applications (may be used in fall-arrest and restraint systems).

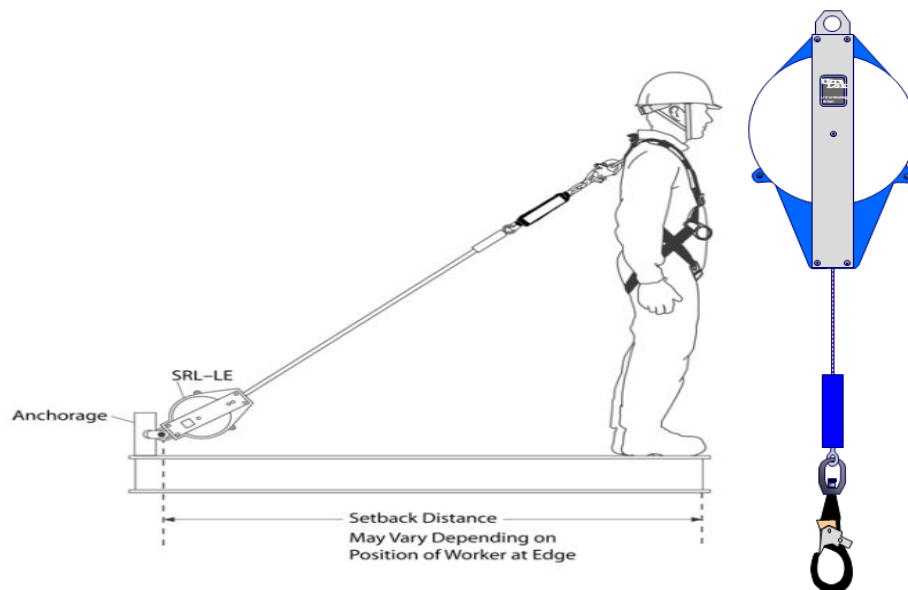

Self Retracting Lanyard W/Leading Edge Capability

(c.3) Self-retracting Lanyards with Rescue Capability (SRL-R)

- (1) Minimum static strength of 3000 pounds
- (2) Minimum mechanical advantage of 3:1



(c.4) Hybrid Self-retracting Devices:

- (1) Combination of two types of the above Self-retracting Devices.

(c.5) Line Characteristics of Self-retracting Lanyards:

- (1) Synthetic Rope or Webbing: shall have a minimum breaking strength of 4,500 pounds (20kN)
- (2) Wire Rope: shall have a minimum breaking strength of 3,400 pounds (15 kN).

(d) Fall-arrestors (FA):

A fall-arrestor is a device that travels on a lifeline and will automatically engage the rope or cable and designed to lock off by inertia to arrest a fall. The device is also called rope or cable grab. Fall-arrestors shall be used on single anchor vertical lifeline and climbing -ladder fall arrest systems.

- (1) Automatic Rope Grab is best for hands free operation, used only in vertical climbing and descending. The device uses inertia locking mechanisms which rely on the rate of acceleration to lock (simply follows the workers as they climb or descend without holding on the device.**
- (2) Manual Rope Grab, also called rope adjuster is used in work positioning and travel restraint applications.**



Fall Arrestors

(III) Body Support

(a) Full-Body Harness:

Straps connected together to contain the torso and distribute the arresting fall forces over the upper thighs, waist, shoulders, chest and pelvis.

There are two styles of harnesses, the first one is the crossover style and the second is the chest strap.

Requirements

- (1) Maximum arresting force on the body shall not exceed 1,800 pounds
- (2) Shall be equipped with a dorsal D-ring integrally attached at the upper back between the shoulder blades, or a D-strap incorporated into the full-body harness
- (3) Shall have permanently attached labels stating the manufacturer's name, serial number or lot number, date of manufacture, capacity, annual Competent Person inspection, and that it meets OSHA & ANSI Z359 FP Code/Product Standards requirements.
- (4) The capacity range, including weight of the user, clothing, and tools, shall be from 130 to 310 pounds.
- (5) All Straps must be connected together properly.
- (6) Conduct a buddy check to make sure the harness is properly donned and connected.
- (7) All newly purchased harnesses shall be equipped with fall-arrest indicator for the Dorsal D-ring and a lanyard parking location (Required for attaching the unused leg of the "Y" lanyard to the harness) and a back strap.

August, 2013



(8) Manufacturers used to test the harness with a rigid weight of 220 pounds. This was based on the conversion factor of rigid weight to the human body is 1.4. A 220-pound rigid weight is equivalent to 310 pounds of human body weight.

Latest studies indicated that the conversion factor is closer to 1.1, not 1.4. The new conversion factor of 1.1 was accepted by the ANSI Z359 Accredited Standards Committee. Converting 310 pounds using the new conversion factor is equivalent to 282 pounds of rigid mass. Exceeding the 310-pound weight becomes more critical with a 1.1 conversion factor. All harnesses shall be tested to 282 pounds.

(9) Lineman's equipment (Use electrically rated harnesses meeting ASTM F887 and ANSI Z359 FP Code/Standards). The full-body harness used around high voltage equipment or structures shall be an industry-designed "lineman's FP harness" that will resist arc flashing and either shall have straps or plastic coated D-Rings and positioning side-rings in lieu of exposed metal D-Rings and exposed metal positioning side-rings. All other exposed metal parts of the linemen's harnesses shall also be plastic coated (e.g., buckles and adjusters). There shall be no metal above the waist.

August, 2013



(Utility harness) Arc Flash Harness
(There is no metal above the waist)

(10) Criteria for donning of the full-body harness:

It is very important and critical the harness shall snugly fit the body;
The user shall be able to reach the Dorsal D-ring with his or her thumb;
There shall be a maximum four flat fingers of slack between the legs and the leg-
straps;
Ensure that the chest strap is across the chest/breast bone.

(11) D-rings and connectors

Requirements:

- (a) Shall have a minimum tensile strength of 5,000 pounds.
- (b) Shall be drop forged, pressed, or formed steel.
- (c) Connectors and D-rings shall have corrosion resistant finish.

(12) D-ring locations on the body harness and uses:

- (a) Dorsal: Fall-arrest, Restrain, and Rescue;
- (b) Sternal: Limited fall-arrest, climbing-ladder FA system, and positioning and rope access;
- (c) Frontal: Climbing-ladder FA system;
- (d) Rear Waist: restraint;
- (e) Hip (Pairs): positioning;
- (f) Shoulder (Pairs): rescue, entry and retrieval;
- (g) Saddle (pairs): positioning.

August, 2013

**(IV) Ropes:****Requirements**

- (1) Synthetic rope lifelines: minimum strength of 5,600 pounds.
- (2) Wire rope lifeline: minimum strength of 6,000 pounds.
- (3) Vertical lifelines: minimum strength of 5,000 pounds.

8.2.4 OTHER FALL PROTECTION SYSTEMS**8.2.4.1 HORIZONTAL LIFELINE (HLL) SYSTEM**

A horizontal lifeline (also called catenary line or static line) is a fall-arrest system, consists of a flexible rope, wire, or synthetic cable that is installed on a horizontal plane (or minimally sloped up to 5%) between two end anchorages and used for attachment of a worker's lanyard or lifeline device which moves horizontally on the horizontal lifeline. A horizontal lifeline is used to control dangerous pendulum-like swing falls. **A Qualified Person for Fall Protection** must design the system. The Competent Person for Fall Protection will review and only approve the installation.

August, 2013

The HLL shall be designed, installed, certified, and used under the supervision of a Qualified Person for Fall Protection, as part of a complete fall-arrest system, which maintains a safety factor of 2. Horizontal lifelines can be either permanent or temporary systems.

8.2.4.1.1 DESIGN CONSIDERATIONS FOR HORIZONTAL LIFELINES:

a. Certain parameters should be taken into consideration when designing horizontal lifelines, such as:

- (1) Initial and maximum deflection or sag of the line.
- (2) Clear span between supports or anchorages.
- (3) Design of anchor points and anchorage connectors.
- (4) Number of workers attached to the system.
- (5) Free-fall distance and total fall distance.
- (6) Minimum clearance below horizontal lifeline system.
- (7) Unit weight of the cable and the line.
- (8) Total weight of all workers attached to horizontal lifeline.

b. The components of typical Horizontal lifeline sub-system may include the following:

- (1) Anchorages and anchorage connectors.
- (2) Lifeline tensioner.
- (3) Cable or rope.
- (4) In-line energy absorber.



HLL

c. There are two types of HLL systems:

- **Type 1: Flexible HLL system designed by the manufacturer of the system and installed and used by the purchaser (or purchaser's representatives) in accordance with manufacturer's requirements.**

- **Type 2: Flexible HLL system is designed and installed by the manufacturer and used by the purchaser of the system (or their representatives) in accordance with manufacturer's requirements.**
- d. **ANSI is developing a new horizontal lifeline standard. Verification testing requirements may include the following tests:**
- (1) Line fittings static test
 - (2) Corrosion Inspection

Unfortunately, with a factor of safety of two, many tests have the potential to activate the lifeline system. Careful consideration is required in determining testing requirements.

e. **Additional Requirements**

- (1) Locally manufactured HLLs are not acceptable unless they are custom designed for limited or site-specific applications by a registered professional engineer who is also qualified in designing HLL systems.
- (2) Commercially manufactured HLLs shall be designed, installed, certified and used under the supervision of QP for FP only, as part of a complete fall-arrest system. The CP for FP may (if deemed appropriate by QP for FP), supervise the assembly, disassembly, use and inspection of the HLL systems, under the direction of the QP for FP.
- (3) The design of the HLL shall include drawings, required clearance, instructions on proper installation, and use procedures, proof testing reports and inspection requirements.
- (4) All HLL anchorages shall be designed by a Registered Professional Engineer who is also qualified in designing HLL systems.**
- (5) The factors that should be taken into consideration for calculating the minimum required clearance for HLL systems include free-fall distance, initial sag of the line, maximum dynamic deflection, length of the lanyard or lifeline, activation distance, of self-retracting lanyards, deployment of energy absorbing lanyards, harness stretch and a safety margin.

Note: Depending on the angle of sag and the line's elasticity, the forces generated by a fall are greatly amplified at the anchorages.

8.2.4.2 SINGLE ANCHOR VERTICAL LIFELINE SYSTEM

- A single anchor vertical lifeline is a vertically suspended line attached to a fixed overhead anchorage independent of the walking/working surface to which a lanyard or device is attached. When single anchor vertical lifelines are used, each employee shall be attached to a separate lifeline. There shall not be

August, 2013

more than one worker attached to a vertical lifeline. Each worker requires his/her independent vertical lifeline.

- Single Anchor Vertical Lifelines shall be protected from sharp edges, and against being cut or abraded by using chafing material.
- The system consists of a fall-arrester attached to a lanyard which is connected to a harness, and designed to move up or down a lifeline (synthetic or wire rope).
- Single anchor vertical lifeline can be used in vertical, sloped or horizontal applications.



Single Anchor VLL

System Requirements:

- (1) Shall have a minimum breaking strength of 5,000 pounds
- (2) Connected to an overhead anchorage that can withstand a force of 5,000 pounds.

Types of Ropes used in Single Anchor Vertical Lifeline Systems:

- **Synthetic Rope:**
 - Made of Polyester, Polypropylene or Nylon;
 - Man-made yarns, fibers or filaments
 - Minimum breaking strength of 5,600 pounds
 - Minimum diameter of $\frac{5}{8}$ inch
- **Wire Rope:**
 - Drawn wires forming strands laid helically over a core or axis;
 - Minimum breaking strength of 6,000 pounds;
 - Minimum diameter of $\frac{5}{16}$ inch.

August, 2013

Automatic Fall Arrestors used in Single Anchor VLL and Descending Applications:

Requirements:

- Average arrest force on the body shall not be greater than 900 pounds;
- Maximum arrest force shall not exceed 1,800 pounds;
- Maximum arrest distance shall not exceed 54 inches;
- Shall be automatic in their locking;
- The total fall distance shall not be greater than 13 feet;
- The FA shall not creep more than 4 inches on the rope during a fall.

Proper Usage:

- If the FA has directional arrow on it, make sure it is pointing along the lifeline to the anchorage. The gravity feed latches prevent the worker from accidentally placing the FA incorrectly on the lifeline.
- After mounting on the lifeline, check to ensure the fall arrestor is working properly by pulling down sharply.
- During a fall, the user may grab on the FA and inadvertently hold it open, the new fall arrestors will be equipped with panic grab; even when the user holds the FA open, it will self-lock and arrest the person automatically.
- Fall arrestors are designed to work with certain types and diameter of ropes or cable.
- Use only automatic travel fall arrestors in vertical or descending applications.
- Fall arrestor and the rope/cable must be compatible.
- Make sure the appropriate size and type of lifeline is used. The required size is marked on the fall arrestor.

8.2.4.3 POSITIONING SYSTEM

The system consists of body harness and a short lanyard attached to a vertical work surface. **Although allowed by OSHA**, ANSI Z359 FP Code/Standards do not permit the use of a body belts by itself; at a minimum, the body belt shall be incorporated in a harness.

System Requirements:

- (1) The system consists of anchorage, one or two short lanyards, and body support, usually a full-body harness and another system as backup.

August, 2013

- (2) The system shall be rigged so that a person cannot free-fall more than 2 feet.
- (3) The system shall be attached to an anchorage capable of supporting 3,000 pounds, or twice the potential impact load of the worker, whichever is greater.

Note: The positioning system (if used alone) is not considered Fall Protection. A positioning system shall not be used as a primary Fall Protection system. A positioning system will require an additional, separate system used as back-up to protect the person from falling.



Positioning System

8.2.4.4 RESTRAINT SYSTEM

Restraint system can be used on horizontal, or mildly sloped, surfaces between 0 and 18.4 degrees (Up to 4 vertical into 12 horizontal).

The system consists of

- a) A safety harness (full-body harness) attached to securely rigged restraint lines;
- (b) **According to OSHA, anchorages used for restraint shall withstand a minimum force of 3,000 pounds unless engineered. According to ANSI Z359.2, the selected restraint anchorages shall be capable of sustaining a 1,000-pound static load (non certified anchorages) or twice the foreseeable force for certified anchorages. Keep in mind that OSHA is the law;**

August, 2013

- (c) The restraint system shall be rigged to allow the movement of employees only so far as the sides and edges of the walking/working surfaces. The person shall not be exposed to a fall hazard;
- (d) Fall-arresters and self-retracting lanyards are prohibited for use as part of a restraint system, or in horizontal applications unless permitted for such use by the manufacturer.
- (e) Lanyard with energy absorbers may be used in a restraint system provided the engineer who is a Qualified Person, has determined whether or not the restraint force could cause the personal energy absorber to deploy, and if so, that such deployment will not permit the worker to reach the Fall-Hazard.
- (f) When using flexible anchorage system such as a horizontal lifeline system as part of a restraint system, pay special attention on how short the lanyard or lifeline needs to be in order that the worker will not reach a Fall-Hazard condition.

Note 1: The terms: *Restraint System*, *Travel Restraint*, *Fall Restraint*, *Work Restraint* and *Travel Restriction*, used and referenced in the new ANSI Z359 Fall Protection Code are the same.

Note 2: It is highly recommended to design or select anchorages for the restraint system as if they were fall-arrest anchorages. It is also recommended that energy-absorbing lanyard be considered and used as part of the restraint system. These precautions would provide some level of protection, in the case of system misuse.



Restraint System

August, 2013

8.2.4.5 SUSPENDED ROPE ACCESS

Requirements:

- (1) Two independent anchorages.
- (2) Two lifelines or ropes attached to the anchorages, a working line, and a back-up safety line. Each one is to be independently anchored.
- (3) Ropes should be of low-stretch kernmantle and arranged so that any abrasion will be avoided.
- (4) Use full-body harness.



8.2.4.6 CLIMBING-LADDER FALL ARREST SYSTEM (LADDER CLIMBING DEVICE SYSTEM)

Climbing Ladder FA system is installed on fixed ladders over 20 feet in length. The 20 feet is the length of the climb (does not include side rail extension of 3-31/2 ft).

Made of rigid rail, cable, or rope;

- (1) Anchorage strength requirement is 3,000 pounds;
- (2) Free-fall distance shall not exceed 2 feet;
- (3) The connector from the frontal D-ring to the tie-off point on the ladder (rope or cable grab) shall be between 9 to 12 inches long;
- (4) Do not attach or install climbing-ladder fall arrest system to off-the-shelf ladders. Per OSHA standard, fixed industrial ladders (off the shelf) having $\frac{3}{4}$ inch rungs are designed to withstand a static load of 500 pounds (Weight of 2 persons). Make sure the ladder is adequate for attaching the Climbing-ladder fall arrest system to it due to the high forces generated by a fall. If a fall

August, 2013

occurs, the $\frac{3}{4}$ inch rungs will not sustain the forces imposed on the ladder; specifically when a cable is used as part of the climbing system;

- (5) Attachment point to the body harness shall be either to the sternal (frontal) D-rings. Consult the manufacturer for the proper connection point;
- (6) There shall be 100% transition at the top of the ladder.



8.2.4.7 WARNING LINE SYSTEM

A warning-line system used during construction work is a barrier erected on a walking and working surface or a low-pitched roof having a slope less than or equal to 4 in 12 (vertical to horizontal), or less than 18.4 degrees, to warn workers that they are approaching a Fall-Hazard.

A warning line system must be erected around all sides of the work area during construction work. Where mechanical equipment is not being used, the warning line shall be erected not less than six (6) feet from the edge of the roof. When mechanical equipment is being used, the warning line shall be erected not less than six feet from the roof edge which is parallel to the direction of mechanical equipment operation. The warning line shall be not less than 10 feet from the roof edge perpendicular to the direction of mechanical equipment operation.

Warning lines shall have the appropriate OSHA compliant flag attached to them.

August, 2013



Warning Line System

(a) For roofing work:

- (1) Installed six to ten feet away from a leading **edge**, and flagged every 6 feet; provide signage stating “warning line.”
- (2) The height of the warning line should be in the range from 34 to 39 inches.
- (3) Shall consist of a rope, wire, or chain, and supporting stanchions.
- (4) A safety person, whose sole job is observation and ensuring a safe working environment, shall be present;
- (5) On minimum sloped surfaces, the line shall be erected 15 feet from the unprotected roof edge.

(b) For other trades working on roofs:

The line shall be installed 15 feet away from the edge of the roof. Other requirements for warning line system are the same as for roofing work.

8.2.4.7.1 WARNING LINE SYSTEM REQUIREMENTS

- (a) The line consists of rope, wires or chains, 34 to 39 inches high, flagged every 6 feet.
- (b) Supporting stanchions shall be capable of resisting a 16-pound force applied horizontally 30 inches from the base of the stanchion.
- (c) The wire, rope or chain shall have a minimum tensile stress of 500 pounds.

August, 2013

8.2.4.8 DESIGNATED AREA METHOD

Designated area method is a system used during general industry work on flat or minimum sloped roofs for conducting inspection of mechanical equipment (other than roof inspections), or conducting other general industry work (e.g., HVAC repairs). **The requirements for Designated Area Method are identical to the warning line system.** In addition to the requirements of the warning line system, a 100% transition is required from the access point to the designated area.

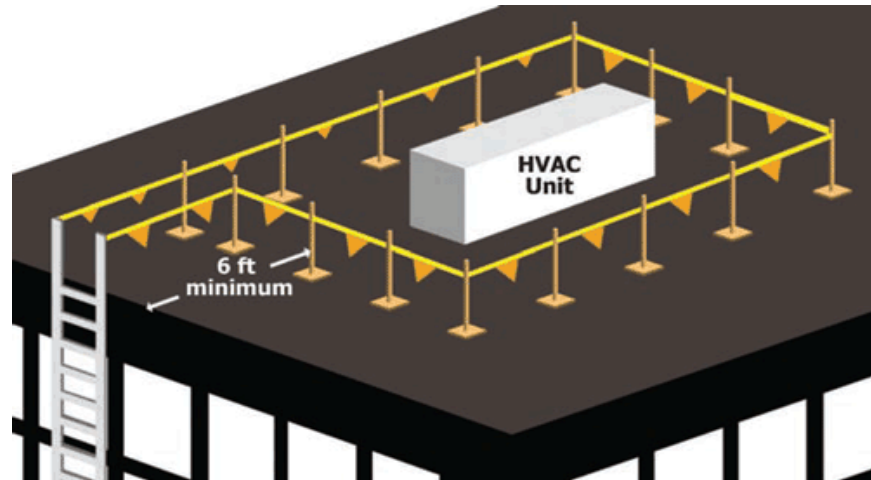

Designated Area Method

8.2.4.9 SAFETY MONITORING SYSTEM (COMPETENT PERSON)

The safety monitoring system shall not be used as a Fall Protection method. A safety monitoring system may be used in conjunction with other Fall Protection systems. “Unified Facilities Guide Specification UFGS 01 35 26 titled Governmental Safety Requirements” and USACE EM 385-1-1 latest edition prohibits the use of the safety monitor as the only Fall Protection method employed. The safety monitoring system may be used with a warning line system as a method of guarding against falls during work on low-pitched roofs and leading edge work only.

A person acting in the capacity of a monitor shall be trained in both the safety monitor duties and warning line system, and shall:

- (a) Have control authority over the work as it relates to Fall Protection.
- (b) Be instantly distinguishable from other members of the work crew by wearing distinguishable markings or a different-colored high-visibility vest.
- (c) Have no other duties while acting as safety monitor.
- (d) Be positioned with a clear unobstructed view, and be able to maintain normal voice communication with all workers under their protection.

August, 2013

(e) Not supervise more than eight exposed workers at one time. Control zone workers shall be distinguished from other members of the crew by wearing a highly - visible vest only while in the control zone.

8.2.4.10 CONTROLLED ACCESS ZONE

- **Controlled access zone shall not be used as a Fall Protection system.**

End of Section

9.0 FALL PROTECTION GUIDELINES FOR SPECIFIC WORK APPLICATIONS

Note: for additional discussion, examples, problems, solutions and applications to specific Fall-Hazards, see Appendix C

9.1 COMMUNICATION TOWERS

MAINTENANCE WORK

- The preferred method for access to existing towers for the performance of maintenance work is by the use of fixed ladders with attached climbing devices because it provides conventional Fall Protection during ascent and descent of the structure.
- To secure permanent anchorage on the tower, the first worker to ascend is the one who installs the self-retracting lanyard for the next worker's use. Work on the tower requires a portable anchor, full-body harness, use of a self-retracting lanyard (SRL), ladder-climbing device, or fall arrestor;
- After permanent anchorage is secured in place, workers who follow the first person up shall require full-body harness, a SRL, single anchor vertical lifeline, climbing fall arrest system, and/or rope grab;
- When working on towers, workers are required to wear fall-arrest equipment at all times.
- All climbing facilities shall be visually inspected daily for rust, corrosion, deterioration, or other hazards on the climbing facilities that could lead to death or injury of an employee in the performance of their duties, at the base of the structure by a Competent Person. Additionally, the climbing facilities shall be visually inspected for these items by the employees as they ascend to the elevation point where work is being performed. If any such hazard is identified during inspection, employees shall not use the climbing facility until such hazards are abated.

9.2 TOWER ERECTION

Personnel Lifting

Before an employee may perform any job related to the hoisting of personnel aloft for work, the employees shall receive training on safe access. The operator of the hoist shall have thorough understanding and comply with sub-rules (1) through (7) of hoisting personnel on hoist lines, as well as following all applicable requirements of P307, USACE EM 385-1-1 and 29 CFR 1926.

(1) An anti-two-block device shall be used on all hoist lines, except where ambient radiation frequency (RF) precludes that use. In such case, a site-specific site rigging

August, 2013

site plan shall be established and maintained on site to ensure that two-blocking cannot occur, and that effective communication between the hoist operator and personnel being lifted is maintained at all times.

(2) A trial lift of the maximum intended personnel load shall be made from ground level to the location to which personnel are to be hoisted.

(3) A pre-lift meeting shall be held before the trial lift at each location and each time a new employee is assigned to the operation.

(4) The Safety Office shall ensure that all trial lifts, inspections, and proof tests shall be performed and documented, and the documentation shall remain on site during the entire length of the project or task.

(5) Employees shall be hoisted to their work stations by using a personnel platform, boatswains chair and/or boatswains seat type and full-body harness.

(6) Employees being hoisted shall remain in continuous sight of, and/or in direct communication with, the operator or signal person.

(7) Employees shall not be hoisted during adverse weather conditions (high winds, electrical storms, snow, ice or sleet) or other impending danger, except in the case of emergency employee rescue.

9.3 ROOF WORK

- **Working within six feet of an unguarded roof edge having a slope less than 4/12:**

During performance of work on low-pitched roofs with a potential Fall-Hazard greater than 4 feet, ensure that employees engaged in such work are protected from falling from all unprotected edges of the roof as follows:

- a. Use restraint or fall-arrest systems or
- b. Use warning-line system or designated area method for other personnel working more than six feet away from the edge.
- c. Mechanical equipment shall be used or stored only in areas where employees are protected by a warning-line system/designated area method, restraint, or fall-arrest systems.
- d. On flat roofs with no parapet or guardrails: When working 6 feet from the edge, use a full-body harness and lanyard for restraint system. Establish a warning line system or designated area method six to ten feet away from the unprotected edge or temporary guardrails for roofing work without fall-arrest system. Personnel working within the warning line system or designated area method do not require Fall Protection. For other trades (i.e. mechanical work) the warning the line shall be installed 15 feet away from the edge.

August, 2013

- **Steep roof (greater than a 4/12 pitch):**

A fall-arrest or temporary guardrail system shall be used when working on steep roofs. Warning line and safety monitor system are prohibited on surfaces exceeding a 4 in 12 pitch, and on any surface whose dimensions are less than 45 inches in all directions. Use a full-body harness, self-retracting device, roof brackets/anchors for anchorage points (single or multiple connections designed for 5000 pounds per person). Also use slide guards.

Note: For additional information and clarification for accessing and working on roofs, see Appendix C, Paragraph C.6.

9.4 LEADING EDGE WORK

- Use horizontal lifelines with full-body harness, and lanyard/self-retracting device, roof anchors, temporary guardrail system, and a restraint system.

9.5 SCAFFOLD WORK

- Use guardrails, cross bracing or full-body harness, and lifelines. During erection and dismantling operations it is highly recommended to have a Fall Protection system. During erection and dismantling of scaffolds an evaluation shall be conducted by the Competent Person to determine the feasibility and safety of providing Fall Protection.
- On supported scaffolds over 20 feet high, use stairs instead of ladders to access the scaffold.

9.6 SUSPENDED SCAFFOLDS INCLUDING SINGLE AND TWO POINT SUSPENDED SCAFFOLDS

- In addition to railing, use an independent single anchor vertical lifeline connected to a full-body harness for every worker in suspended scaffolds.
- Full-body harness is to be connected to the fall-arrester (rope grab) on the single vertical lifeline with a lanyard no longer than 3 feet;
- The rope of the vertical lifeline shall be of the material and diameter compatible with requirements as marked on the fall-arrester;
- The suspended scaffold shall be maintained in accordance with manufacturer's instructions and specifications.

August, 2013



Single Point Scaffold

Two Point Scaffold

9.7 AERIAL WORK PLATFORMS

APPLICABLE EQUIPMENT:

1. Vehicle mounted Rotating and Elevating Aerial Devices -ANSI A92.2 (Figure – 1)
2. Manually Propelled Elevating Work Platforms - ANSI A92.3 – (Figure – 2)
3. Boom Supported elevating Work Platforms - ANSI A92.5 (Figure - 3)
4. Self Supported Elevating Work Platforms/Scissor Lifts - ANSI A 92.6 (Figure – 4)

Note: Platform means a portion of aerial work platform (AWP) such as bucket, basket, stand or equivalent that is designed to be occupied by personnel.

9.7.1 AERIAL LIFT EQUIPMENT

- Aerial Lifting Equipment including Vehicle mounted Rotating and Elevating Aerial Devices (**ANSI A92.2 equipment**) and Boom Supported elevating Work Platforms (**ANSI A92.5 equipment**) usually have either a platform surrounded by guardrails (e.g., JLG) or a basket (i.e., “cherry picker”) used to raise and lower employees.

Aerial lifting equipment that has a boom (articulating or non-articulating) sometimes is subjected to “hanging up” on a protruding object while being raised, and jolting the man-platform or basket when releasing from the caught projection. This upward jolt can propel (eject) an employee from the man-platform or man-basket. Employees in an aerial lift must be connected with a restraint system. Occupants always shall stand firmly on the floor of the basket, and shall not sit or climb on the edge of the basket or use planks, ladders, or other devices for a work positioning.

- Occupants in aerial lifts shall always be tied off using a restraint system to protect an employee from being ejected from the man-platform or man-basket. It is important that the restraint system keep the employee from being ejected over the guardrail or out of the basket. If an employee were to be ejected over the guardrail, the resulting momentum force could be sufficient to tip over the aerial lift, if the boom were raised high enough and the resulting momentum forces great

August, 2013

enough. The best connecting device option is an adjustable energy absorbing lanyard.

- Always use a full-body harness in a restraint system. Aerial lifts often have designed anchorages at the platform level, knee level, or waist level. Depending on the level of the anchorage point and the tie-off point on the full-body harness (at the dorsal D-ring), the lanyard selected must be short enough to prevent ejection from the man-platform or man-basket. For example, if an employee were wearing a full-body harness with a six-foot lanyard connected to the dorsal D-ring, the lanyard necessarily would be connected at the foot level in order to prevent ejection over the guardrail or out of the basket. Exception: A six-foot lanyard could be used connected to an anchorage higher than foot level, if it were a tie-back or adjustable style in which the lanyard could be shortened. A lanyard with a shock-absorber can be used in a “restraint system” since the employee will not experience forces great enough to deploy the shock-absorber.
- Before elevating the work platform of a boom-supported articulating lift, the operator shall verify that all occupants’ full-body harnesses are on, and donned properly.
- The use of self retracting devices is not permitted in aerial lifts.

9.7.2 SCISSOR LIFTS

- Self Supported Elevating Work Platforms/Scissor Lifts (ANSI A92.6 Equipment) four feet or higher shall be equipped with standard guardrails. In addition to the guardrail provided, the equipment shall be equipped with anchorages meeting ANSI Z359, Fall Protection Code/Standards.
- A restraint system shall be used in addition to guardrails. Lanyards used with the restraint system shall be sufficiently short to prohibit workers from climbing out of, or being ejected from, the platform. It is highly recommended to use adjustable energy absorbing lanyards. Scissor lifts equipped with anchorages that do not meet ANSI Z359, Fall Protection Code/standards shall not be used or shall be removed from service. Should the worker’s feet leave the floor of platform of the elevated scissor lift, or the worker is required to exit the lift at height, continuous Fall Protection must be provided. The worker must be connected to an anchorage point outside of the scissor lift or mobile scaffold before opening the swing gate and stepping out of the work-platform. The worker must not be simultaneously connected to the work-platform and to an anchorage point outside of the work-platform, in case the scissor lifts were to travel.

9.7.3 MOBILE SCAFFOLDS

- **Manually Propelled Elevating Work Platforms (per ANSI/SIA A92.3).** The platform of the mobile scaffolds shall be equipped with standard guardrail. In addition to the guardrail provided, if the platform is equipped with a manufactured anchorages meeting ANSI Z359 Fall Protection Code, a restraint system shall be used in addition to the guardrails. Lanyards used with the restraint system shall be

August, 2013

sufficiently short to prohibit workers from climbing out of, or being ejected from the platform. Lanyards with built-in shock absorbers are acceptable. The use of a self retracting device is not acceptable.

- The platform shall not be occupied when moved and at no time will workers be allowed to climb on or over the guardrails. In case the wheels of mobile scaffold are chocked and brakes locked; then the workers should be connected to a “restraint system”. The purpose of a restraint system is to prevent the worker from being ejected over the guardrail if the mobile scaffold was to hit a pot-hole or other sudden change in elevation while moving.

9.7.4 SAFETY OPERATING PROCEDURES FOR PREVENTING AERIAL WORK PLATFORMS FROM TIPPING OVER AND CAUSING FALL MISHAPS

9.7.3.1 Safe Use:

- There are hazards associated with using AWP's that can be minimized if the work is accomplished using the appropriate equipment for the specific task and job site.
- The equipment should only be used for the intended application. Never attempt to use the equipment as a crane and never load the platform beyond its maximum rated capacity.
- Operators should park the equipment on level and stable ground and operate it within the design specifications and instruction of the manufacturer.
- Before the equipment is used and during use, the operator should check the work area for possible hazards such as, but not limited to:
 - Trenches, holes or openings, including those concealed by water, ice, mud, etc.
 - Sloping or uneven ground or floor
 - Debris, bump and floor obstructions
 - Wind and weather conditions
 - Inadequate surface and support to withstand all load forces imposed by the machine in all directions
 - Overhead obstructions and electrical conductors
 - Presence of personnel below or in the immediate vicinity
 - Hazardous location and atmospheres

During use, the operator should maintain:

- Clear view of the path of travel
- Safe distance from trenches, obstacles, debris, drop-offs, holes, and depressions, ramps, and other hazards to ensure safe travel
- Safe distance from overhead obstacles
- Never move the AWP with occupants in and elevated platform, basket or bucket
- Manually propelled platforms shall not be occupied when moved

August, 2013

Prior to elevating the platform, the operator should verify the access gate or opening is closed per manufacturer's instructions.

Tying off to an adjacent structure or pole is not permitted unless a safe device for 100% tie-off is used for the transfer.

**Figure 1
Vehicle-Mounted Elevating Work Platform**

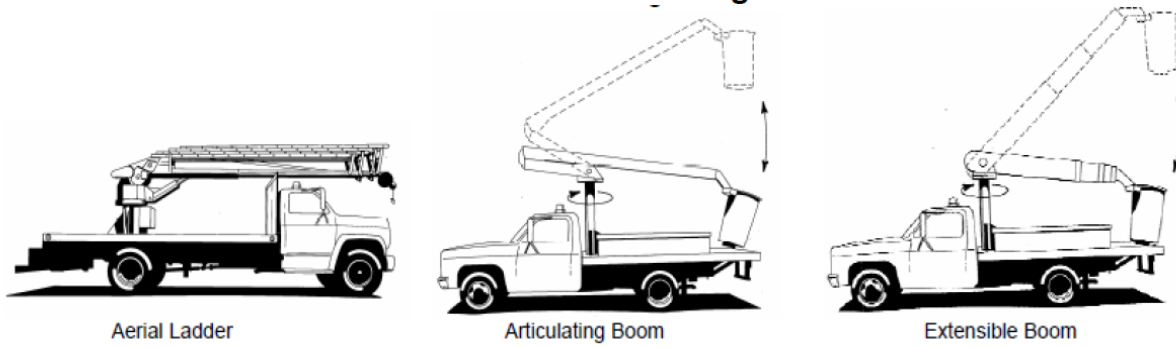

**Figure 2
Manually Propelled Elevating Work Platform**

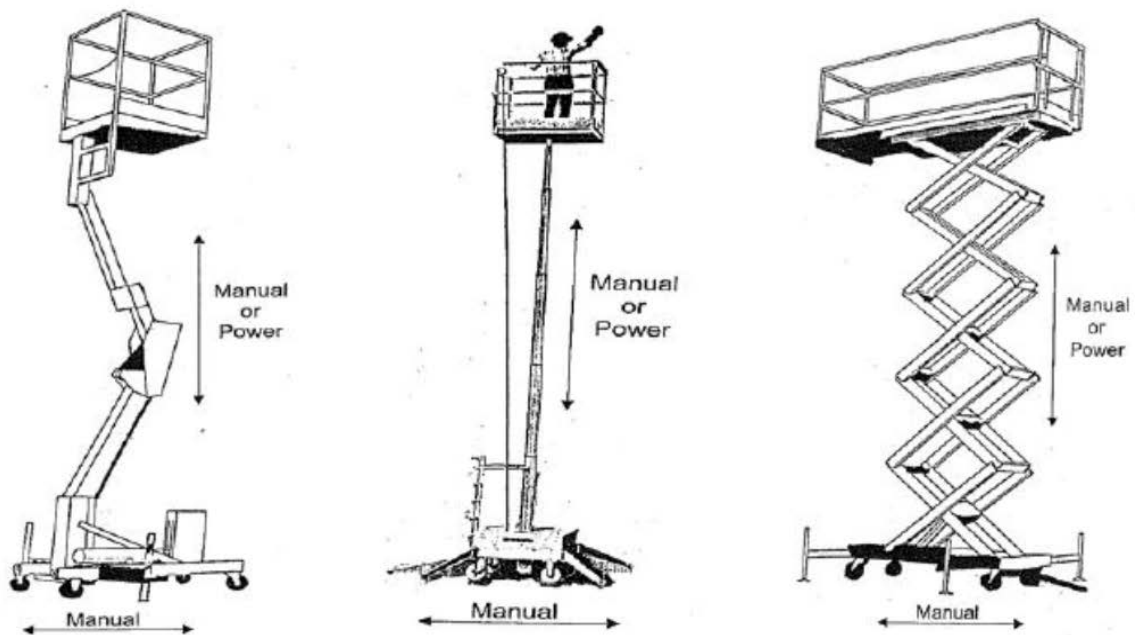

Figure 3
Boom-Supported Elevating Work Platform

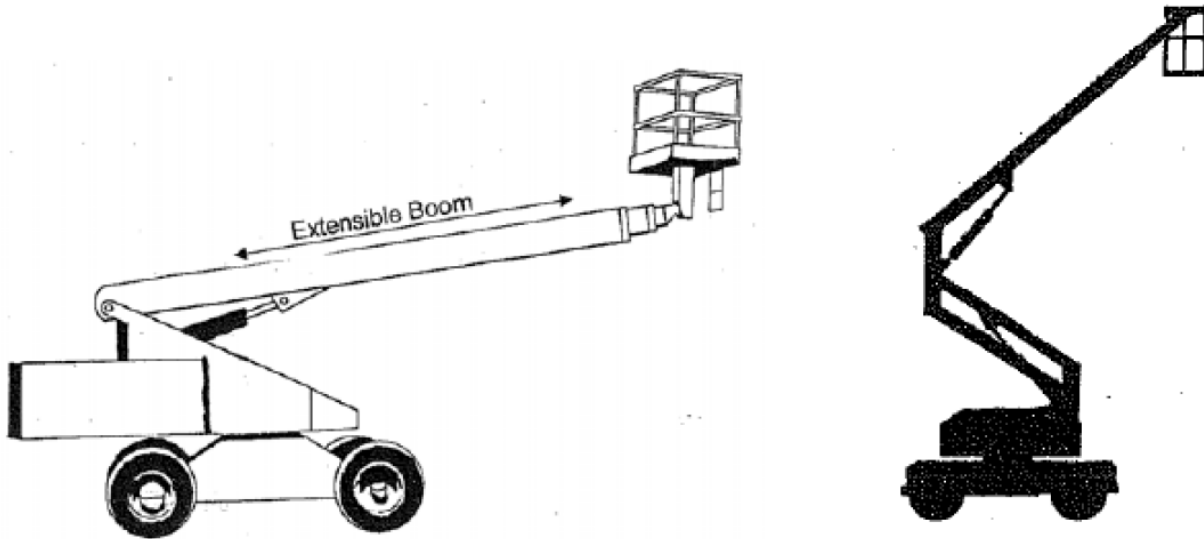
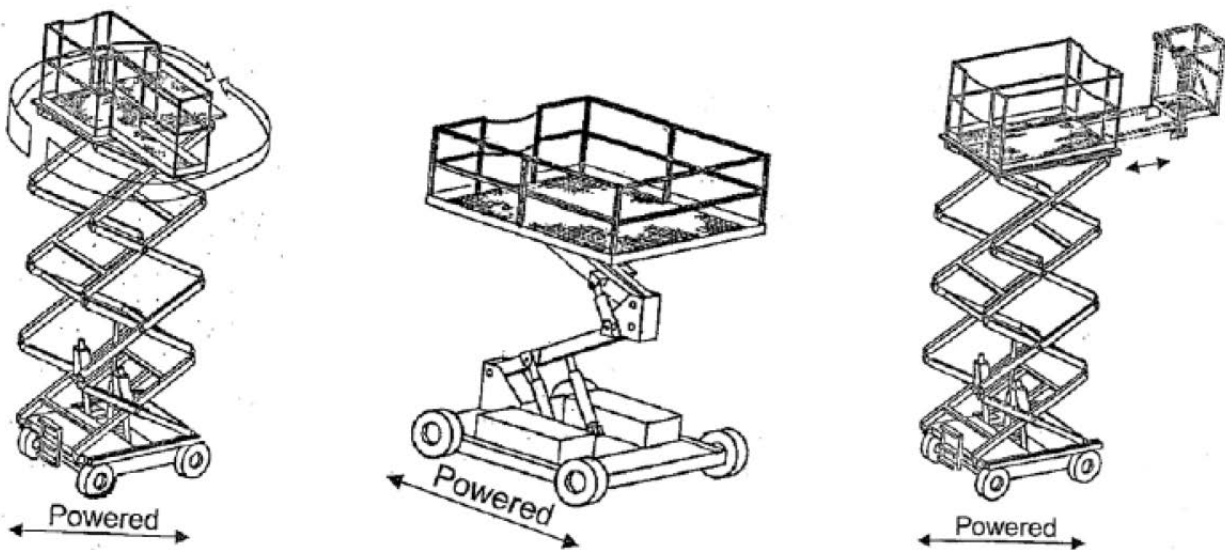

Figure 4
Self Propelled Elevating Work Platform



Scissor Lifts

August, 2013

9.8 CONFINED SPACE ENTRY

In a confined space, if there should be a hazard of exposure to vertical fall, before entering such a space the person entering shall be tied to a lifeline, SRL, and rescue and retrieval equipment. A co-worker, who is able to retrieve the victim by utilizing the retrieval mechanism from outside the confined space without difficulty, must be present.



Tripod used for safe entry

9.9 EXCAVATED TRENCHES OR HOLES DEEPER THAN SIX FEET

- Provide temporary guardrails on both sides of the trench, or around holes, or establish a warning line system. Any person crossing this line or guardrails is required to have Fall Protection.

9.10 COVERS

“Hole” is defined as a gap or void one inch (per 29 CFR 1910.23) or more in its least dimension in a floor, roof, or walking/working surface (According to 29 CFR 1926.500, a hole 2 inches in its least dimension requires a cover); or a gap or opening in flooring, stairway, ramp, or roofing two inches or greater through which material or tools can fall through; or, in the case of larger holes, a person can step or fall through. In either case, FP in the form of a secured and marked covering or barricade is required. Examples include manholes, pits, tanks, skylights, open shafts, chutes, and hatches. Consideration also should be given to guarding holes which may present a trip or entrapment hazard.

August, 2013



Cover

If there should be a danger of falling through a skylight opening, a standard screen/mesh cover or temporary or permanent guardrail system must be installed on all sides of the skylight.

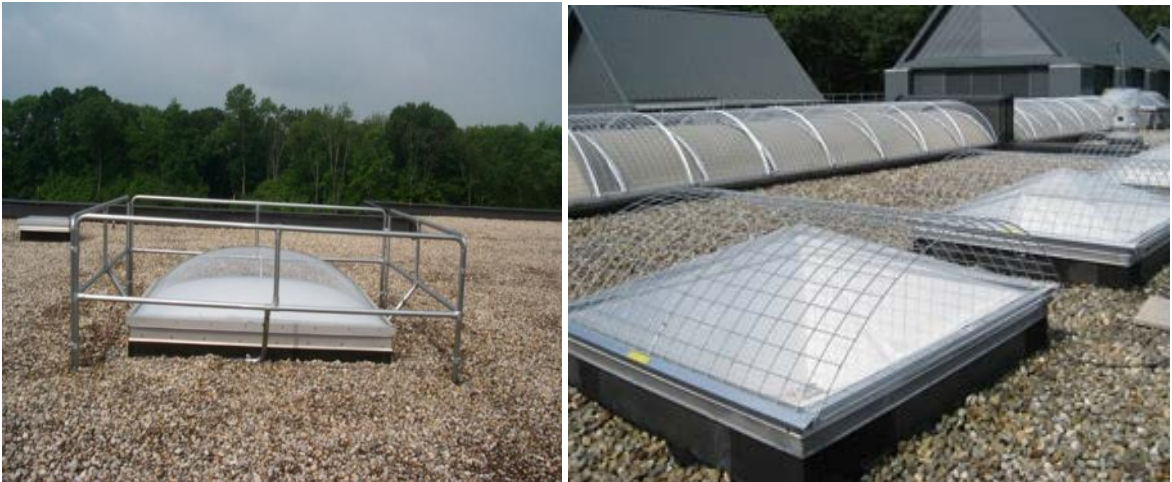

Trenches, utility covers, and other similar features — when located in a roadway or vehicular aisle — shall be designed to carry twice the maximum axle load of the largest vehicle expected to cross over.

9.11 SAFE WORK PRACTICES ON LADDERS AND STAIRS

9.11.1 FIXED LADDERS

- An employee shall not perform work from a fixed ladder unless he/she is wearing Fall Protection; such as a full-body harness attached to a climbing-ladder fall-arrest system or self-retracting Device which in turn is attached to a properly designed and

August, 2013

installed anchorage. If light work is performed from a ladder, use one hand for gripping stability on a rung and the other hand for performing light duty work and by maintaining three points contact at all times (two feet, one hand, or two hands and one foot). When climbing the ladder maintain a three point control by holding on the horizontal rungs with both hands instead of holding on the vertical side rails.

- If the total length of the climb on a fixed ladder equals or exceeds 20 feet, the following requirements must be met: fixed ladders must be equipped with either (a) climbing ladder fall arrest system, or (b) self-retracting device.
- All climbing-ladder fall arrest systems shall use automatic fall arrestor permitting the worker to ascend or descend without continually having to hold, push, or pull any part of the device, leaving both hands free for climbing. These climbing ladder fall arrest systems must be activated within 2 feet after fall initiation. Climbing-ladder fall arrest system shall be attached to a frontal (sternal) centered D-ring or other specifically designed centered frontal attachment point on a full-body harness.
- The side rails of the ladder extensions must extend 42 inches above the top level or landing platform or working surface served by the ladder, and must afford a “power grip” (hand must be able to encircle or almost encircle the side rail).

Note: Although allowed by OSHA, Ladder cages or “wells” do not provide safe Fall Protection. They cannot stop a fall. The purpose of the ladder cage is to afford the worker the ability to lean back and support him-self or her-self if necessary to rest during climbing.

9.11.2 PORTABLE AND EXTENSION LADDERS (NON-SELF- SUPPORTING)

- The ladder shall be placed so as to prevent slipping, or it shall be lashed, or held in position (tied);
- An employee may perform work from a non-self-supporting portable ladder placed at the correct angle and properly secured (e.g., lashed top and bottom), if the employee is facing the ladder and his or her body is between the side rails, and he/she uses one hand to grasp the ladder, with both feet on the ladder rungs.
- Non-self-supporting ladders must be used at an angle where the horizontal distance from the top support to the foot of the ladder is approximately one-quarter of the working length of the ladder.
- An employee must use at least one hand to grasp the ladder when climbing and when ascending or descending the climber must face the ladder.
- An employee shall not stand or work from the top three rungs of a non-self-supporting portable ladder.

August, 2013

- The spacing of rungs or steps of a portable ladder shall be at 12-inch centers, and the minimum clear width between side rails of a straight ladder or any section of an extension ladder shall be 11.5 inches.
- The length of single ladders or individual sections of ladders shall not exceed 30 feet. Two-section ladders shall not exceed 48 feet in length, and ladders with more than two sections shall not exceed 60 feet in length.
- Where a portable ladder is used for access to an upper landing surface, the side rails must extend at least 3 feet above the upper landing surface. Where such an extension is not possible, the ladder must be secured, and a grasping device such as a grab rail must be provided to assist workers in mounting and dismounting the ladder. In no case shall the extension be such that ladder deflection under load would, by itself, cause the ladder to slip off its support.
- The top of a non-self-supporting ladder must be placed with two rails supported equally, unless it is equipped with a single support attachment.
- Do not paint wooden ladders – paint hides defects, and can create a slippery climbing surface.
- Single-rail ladders shall not be used.
- An employee shall not carry any object or load that could cause the employee to lose balance and fall.

9.11.3 PORTABLE LADDERS – SELF-SUPPORTING

(STEP-LADDERS)

- Neither the top of a step-ladder nor the step below the top of the ladder (top step) shall be used as a step, nor used to stand on while performing work.
- Do not use a closed step-ladder as a straight ladder – it may slip out.
- Stepladders shall not exceed 20 feet in length.
- The steps of a step-ladder must be corrugated, knurled, dimpled, coated with skid-resistant material, or treated to minimize slipping.

9.11.4 STAIRWAYS

- Stairways having four or more risers, or rising more than 30 inches in height, must have at least one handrail; however, where stairs serve as means of egress, they shall have two handrails. A stair-rail also must be installed along each unprotected side or edge. The top rail of a stair-rail is required to be 42 inches above the walking surface; and stair handrails must be no more than 38 inches or less than 34 inches from the upper surface of the stair-rail to the surface of the tread. The reason for the maximum height of 38 inches is that it is found that people of average height don't grasp handrails higher than 38 inches, because it is not comfortable on

August, 2013

their shoulders. The international Building Code (IBC), the International Fire Code (IFC), and the National Fire Protection Association (NFPA 101) Life Safety Code require the height of new permanent handrails to be 34-38 inches, and 42 inches for permanent stair-rails. Existing handrails may be no less than 30 inches above the nose of stair treads.

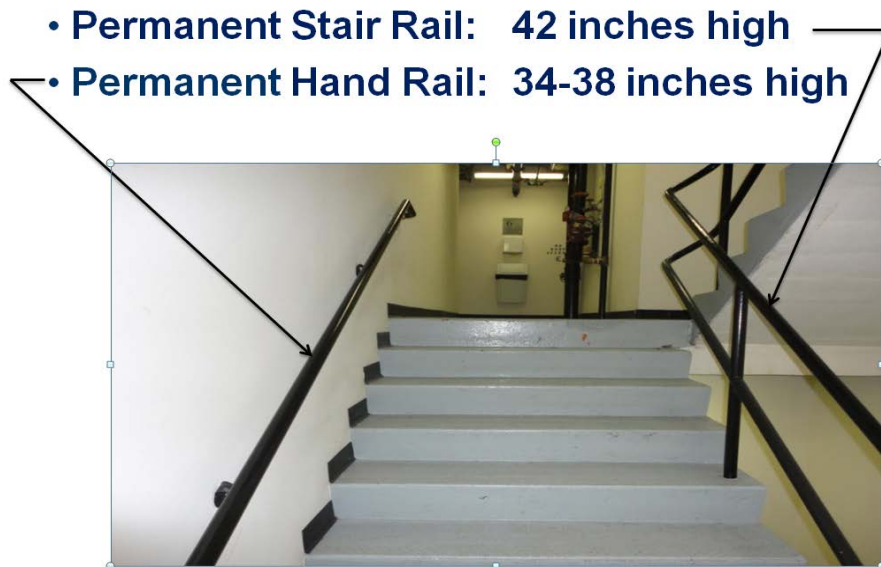

- Mid-rails, screens, mesh, or intermediate horizontal members must be provided between the handrail and stairway nosing. In these applications, Intermediate horizontal members, when used, must not be more than 19 inches apart.
- Unprotected sides and edges of stairway landings must be provided with a top-rail 42-inches in height (+/- 3 inches) and horizontal midrail or mid-rails spaced no more than 19 inches apart. A toeboard also is required. .

9.12 WORKING NEAR WALL OPENINGS

- Wall opening: An opening at least 30 inches high and 18 inches wide, in any wall or partition, through which persons may fall.
- Any time work is performed near a wall or window opening where there *is a Fall-Hazard to a lower level*; Fall Protection must be provided (e.g., guardrail or fall arrest system).

9.13 WORK OVER WATER

- Employees working 4 feet or more above the water or liquids must be protected from falling by providing Fall Protection (e.g. guardrails, fall-arrest equipment, etc.). Additionally, employees working over or near water, where the danger of drowning

August, 2013

exists, also shall wear U.S. Coast Guard-approved lifejackets or buoyant work vests. At least one lifesaving skiff with an available operator shall be present at locations where employees are working over, near, or adjacent to, water that they might fall into. Ring-buoys and a skiff must be provided, irrespective of the Fall Protection provided. Ring-buoys and skiffs address the hazard of falls that may occur in the event of a lapse in use of fall-arrest equipment. Where work over water is performed, a “Man Overboard” plan shall be prepared and used:

Additional Requirements:

- When continuous Fall Protection is used without exception to prevent personnel from falling into the water, in this situation, the risk of drowning has been effectively removed and PFDs are not required.
- Where water directly abuts the structure and the distance from walking/working surface to the water is 25 feet or more, personnel shall be protected from falling by the use of Fall Protection system, and PFDs are not required.
- Where the distance from the walking /working surface to the water surface is less than 25 feet and the water depth is less than 10 feet, or hazards from machinery, barges, camels, or other structures fastened to and directly abutting piers, quay walls or wharves, FP is required. Where fall-arrest equipment is used, anchorages must be identified;
- Working from/in machinery (aerial lift equipment, cranes, or other mechanically operated equipment) directly over water, and the depth of water is at least 10 feet, Fall Protection is not required, however, personal floatation devices are required – do not use FP equipment.
- Where certain locations or situations make FP infeasible or impractical, this does not justify such exceptions as the norm throughout.
- If utilizing both PFD and full body harness, the full body harness shall be worn under the PFD. The type of PFD used shall not interfere with proper use of the full body harness and lanyard.

The following is a flow chart explaining when PFD or fall protection is required:

August, 2013

Flow Chart --FP Requirements for Working Over or Near Water

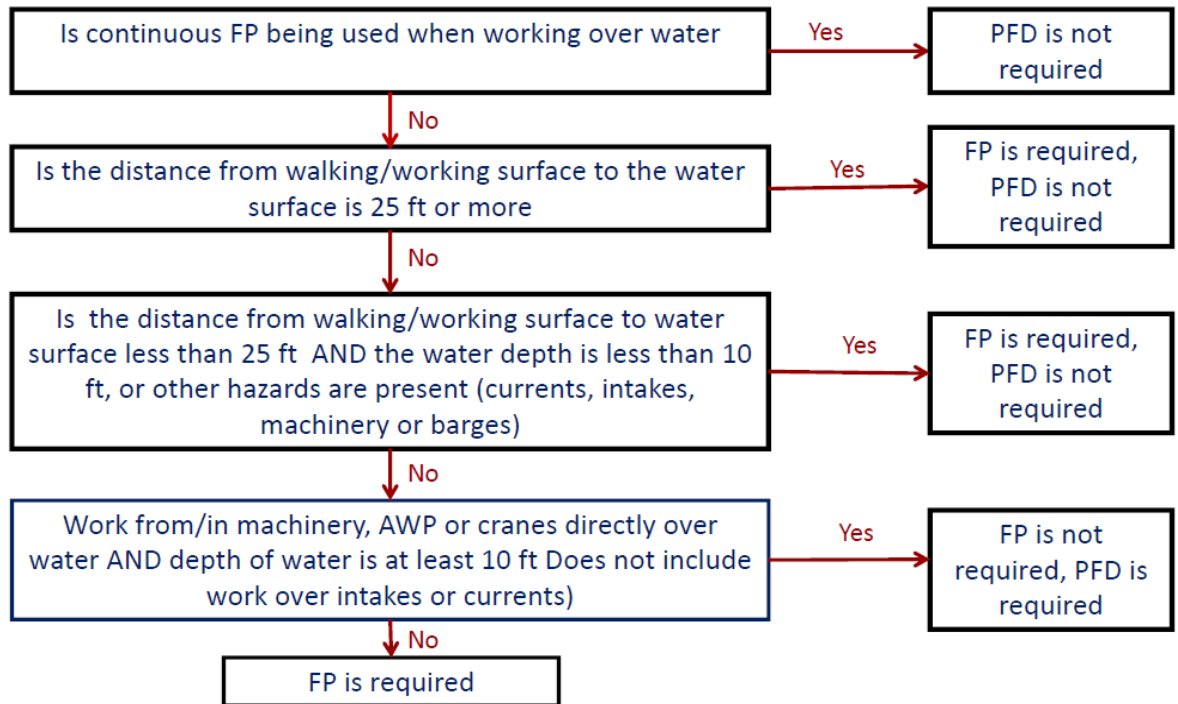

(For Sample Man Overboard Plan, see Appendix D).

9.14 AIRCRAFT MAINTENANCE WORK

(SEE CHAPTER 15)

9.15 ELEVATED WORK AREA NEAR GUARDRAILS

Wherever an employee climbs above the flooring (e.g., climbs a step ladder placed on a platform) of a lift, catwalk, platform, scaffold, elevated work platform, or stairway above 4 feet (5 feet in shipyard operations and 6 feet performing construction) or working on stilts, thereby reducing the height of the top rail in relation to the employee to less than 42 inches (plus or minus 3 inches), the height of the guardrail must be raised accordingly to maintain a protective height of 42" above the stilt or raised platform/work-stand height. If this is not possible, use another Fall Protection system.

August, 2013

9.16 OTHER ENGINEERED FALL PROTECTION SYSTEMS

Commercially available engineered systems are recognized as effective Fall Protection and may be used. Commercially available engineered systems shall be designed, installed, certified and used under the supervision of a QP for FP only. They shall be used per manufacturer's instructions and recommendations. The CP for FP may (if deemed appropriate by the QP for FP), supervise the assembly, disassembly, use, and inspection of the engineered system, under the direction of the QP for FP. The design shall include drawings, required clearance, and instructions on proper installation, use, and inspection requirements.



Sky Web

9.17 LADDER CAGES

Ladder cages may be required per varying standards and regulations, but it must be clearly understood that the installation and or use of cages does not provide adequate protection or mitigation of Fall-Hazard.

End of Section

10.0 GUIDANCE FOR FALL RESCUE PROCEDURES

10.1 INTRODUCTION

A person is working at heights, using Fall Protection equipment, may require rescue if that person falls and is suspended in a harness. Prompt rescue is very important. Studies show that a person suspended in a harness may have blood circulation problems within a few minutes. Accordingly, a site-specific “Rescue Plan” must be prepared in writing and maintained for all instances where personnel work at heights and are exposed to Fall-Hazards. The “Rescue Plan” shall contain detailed procedures on the methods of rescue; methods of self-rescue; equipment used; training requirements; specialized training for rescuer(s); procedures for requesting rescue; and available medical assistance. Where the rescue may not be, or cannot be, solely performed by a jurisdictional public (e.g., city fire department) and/or government-emergency response agency (e.g., government fire department), then the “Rescue Plan” must contain detailed procedures for planned rescue methods.

The “Rescue Plan” is a part of the written “Fall Protection and Prevention Plan” and contains provisions for potential self-rescue or assisted rescue of an end-user of Fall Protection. The “Fall Protection and Prevention Plan” covers every Fall-Hazard to which end users are exposed.

Another important document is the “Pre-Incident Plan”. A “Pre-Incident Plan” is a formal written plan, prepared jointly by the host Navy or Marine Corps activity and the fire emergency responders, containing factors to be evaluated when assessing the potential situations (e.g., fuel storage tanks, energized power cables, hazardous material, Fall-Hazards) that could affect a facility during emergency conditions. The “Pre-Incident Plan” is prepared, reviewed, updated, and approved by a Competent Person for Fall Protection. The Fall Protection Program Manager from the activity reviews and concurs with that portion of the “Pre-Incident Plan” which addresses rescue of a person who has fallen and is suspended in a harness, and incorporates this information into the “Rescue Plan”.

10.2 BACKGROUND

Following a fall from a height, the end-user of Fall Protection who is wearing a body harness properly secured to an anchorage may be suspended in the harness for a length of time if self-rescue or rescue by co-workers cannot be performed quickly. Sustained immobility in a body harness may lead to suspension trauma also known as harness-induced pathology as described in reference (a). Suspension trauma resulting from the accumulation of blood in the veins is commonly called venous pooling. The symptoms (known as orthostatic intolerance) of suspension trauma include light-headedness, dizziness, weakness, and occasionally, fainting.

Normally, when an individual faints and collapses onto a flat surface, the pooled blood now no longer is being held down by gravity, and returns to the heart, where it is once again

August, 2013

distributed to the body. Assuming no injuries are caused during the collapse, the individual will quickly regain consciousness, and recovery is likely to be rapid.

When an individual hangs in a harness in a vertical or near-vertical position without leg motion, the same thing can happen; however, in this case when consciousness is lost, the person remains vertical. An accumulation of blood in the legs reduces the amount of blood in circulation. After an initial speeding up of the heart beat, the heart rate then slows, and blood pressure will diminish in the arteries. The reduction in quantity and/or quality (oxygen content) of blood flowing to the brain leads to unconsciousness and harmful effects on other vital organs. If these conditions continue, they potentially may be fatal.

The importance of a timely rescue of a worker suspended in a harness, or who has become incapacitated due to an injury and/or heart attack, mandates the need for a written rescue plan.

10.3 GENERAL REQUIREMENTS

Before an end-user of Fall Protection is exposed to a Fall-Hazard, and before starting work activities, the Fall Protection Program Manager and the end-user shall ensure that there are pre-incident plans and rescue plans in place that address the rescue of a person who has fallen and becomes suspended in a harness. If a pre-incident plan is not available, the Fall Protection Program Manager may work with the base safety office/officer, to obtain information from the jurisdictional public/Government-emergency response agency, including emergency contact phone numbers and rescue capability. They then shall include this information in the rescue plan, along with alternative/supplemental rescue methods required to perform a timely rescue of an end-user suspended in a body harness, or one who is incapacitated at heights for other reasons. End-users of Fall Protection shall be trained in the methods for minimizing the effect or delaying suspension trauma if an end-user is suspended in a body harness and unable to perform a self-rescue and needs to wait to be rescued (e.g., keep legs moving and raise knees to the body, to help prevent the pooling of blood in the legs).

Suspension straps attached to the harness can be used to minimize the effect of suspension trauma while the user is waiting for rescue. A strap for each leg is recommended. All end-users should be trained in the safe use of the straps.

10.4 INITIATION OF RESCUE

End-user using Fall Protection equipment shall have an assigned safety person (spotter), also known as the “buddy system”, who is within visual and aural range of the end-user. The duty of the assigned safety person is to check periodically (at least every 5 minutes) to assure that the end-user has not fallen and become suspended in the harness. The assigned safety person shall have the capability to make quick contact with the jurisdictional public- or government-emergency response agency; or the end-user (or the team leader of a group of end-users) shall have this capability, in the case of the end-user or team visiting another Navy or Marine Corps activity.

August, 2013

10.5 FALL-ARREST RESCUE PLAN AND PROCEDURES

A site-specific rescue plan (for an employee suspended in a body harness after a fall) shall be prepared in writing by the Navy or Marine Corps activity; or by the end-user or the supervisor of a group of end-users, in the case of the end-user or team visiting another Navy or Marine Corps activity, and shall include the following:

a. Pre-incident Planning. Per reference (c) (the *NFPA 101 Life Safety Code*), a written pre-incident plan is prepared by the jurisdictional public (e.g., city fire department) and/or government-emergency response agency (e.g., government fire department). As per reference (c): *“Pre-incident planning is ensuring that responding emergency personnel know as much as they can about a facility’s construction, occupancy, and fire protection systems before an incident occurs. With this knowledge, the fire department can compare a potential incident at the facility with its available resources and plan the department’s response accordingly. Pre-incident planning is not restricted to building components. It includes other factors and conditions that may be relevant to an emergency at a particular site.”* The Fall Protection Program Manager, or the end-user (or team leader of a group of end-users, in the case of the end-user or team visiting from another activity) shall verify that rescue procedures are in place for any workplace where the authorized rescuer will perform a rescue. The types of Fall Protection systems being used and the work environment shall be reviewed with the jurisdictional public and Government-emergency response agency. The pre-incident plan shall be reviewed and updated by the Navy or Marine Corps activity’s Fall Protection Program Manager annually, or whenever there is a change to the job-site that will affect items in the plan.

b. Methods of Rescue.

(1) Jurisdictional Public Emergency-Response Agency.

(2) Government Emergency-Response Agency.

(3) Assisted Rescue: The written rescue plan shall include instructions for contacting rescue personnel, plus a description and verified location of all equipment to be used by the rescue team (e.g., scissors lift or aerial lift), and complete instructions and procedures for performing rescue safely and promptly.

(4) Self-rescue. An end-user who has fallen and is suspended in a fully body harness and not incapacitated (e.g. an injury, stroke or heart attack), can usually perform a self-rescue, where the following conditions exist:

(a) The end-user can reach an adjoining structure, and has the strength and mobility to pull up and onto the structure.

(b) The end-user has a self-deploying or manual-deploying coiled webbing rescue ladder attached to lanyard anchorage, which after a fall allows climbing up to the anchorage point (or at least simply standing in the ladder, allowing the necessary circulation of blood to the entire body while an assisted rescue is being commenced).

(c) An “automatic or manual controlled descent device” can be used as a self-rescue device if it is attached to a separate anchorage point (minimum 3,000-pound strength) and a vertical tag-line is attached to the controlled descent device’s safety snap-hook which can be reached by the employee suspended in the full-body harness. The tag-line is pulled, bringing down the self-retracting line from the controlled descent device, and the descent device safety snap is attached either to the back “D” ring or front rescue “D” ring of the fully body harness, and the deployed shock absorber lanyard detached (this method is only viable if there is a “quick release” device which will allow the disconnecting of the shock absorber lanyard under tension). Once the deployed shock absorber lanyard is disconnected from the fully body harness, the controlled descent device will allow the end-user to descend at a controlled rate to a lower level. This method requires “hands-on” training.

10.6 RESCUE EQUIPMENT INSPECTION

Inspection of equipment used by the jurisdictional public- and government-emergency response agencies is the responsibility of these agencies. Prior to use, the end-user of Fall Protection shall inspect the self-rescue and assisted-rescue equipment to ensure that it is in safe working condition, and has been protected against damage from the weather (e.g., UV, water) and from workplace conditions (e.g., chemical, physical). Annually, a Competent Person in Fall Protection shall verify that the rescue equipment markings and instructions are consistent with ANSI and OSHA Standards, and that the rescue equipment has been maintained in accordance with manufacturer’s instructions.

10.7 TRAINING REQUIREMENTS FOR RESCUE

Training is required for self-rescue techniques. All personnel who will work at height utilizing fall protection equipment shall be trained in self-rescue techniques. They shall be trained in these techniques before utilizing Fall Protection and annually thereafter.

(a) Specialized Training for the Rescuers. Training of rescue personnel at jurisdictional public- and government-emergency response agencies are the responsibility of those agencies. For assisted-rescue the authorized rescuers shall be properly trained and shall be proficient at performing a rescue of a person suspended in a harness or who has become incapacitated at heights. The authorized rescuer shall be knowledgeable in the selection, use, storage, and care of all equipment necessary to perform rescue on end-users from all types of Fall Protection equipment. Carefully evaluate hazards associated with rescue and determine whether or not it is safe to perform rescue. The authorized rescuer shall conduct a site-visit to the work location prior to writing a post-fall-arrest rescue plan. The authorized rescuer shall assign and delineate various responsibilities in the rescue and evacuation of an employee who has become incapacitated at heights and/or who is suspended in a body harness after a fall. Authorized rescuer training shall be conducted once every two years and evaluated at least annually by a Competent Person rescuer and shall include the following:

- (1) Fall-Hazard recognition, elimination and control methods.

August, 2013

- (2) Applicable Fall Protection and rescue regulations and standards.
- (3) Understanding and using the “Fall Protection and Prevention Plan”, and the “Rescue Plan”.
- (4) Inspection and maintenance of the equipment including manufacturers’ instructions.
- (5) Proper uses of various rescue equipment.
- (6) Practical applications and drilling scenarios for rescue (Hands-on Training).

10.8 PROCEDURES FOR REQUESTING RESCUE AND MEDICAL ASSISTANCE

The telephone number for jurisdictional public- and government-emergency response agencies is usually 911, or 9-911, depending upon the Navy or Marine Corps activity. If the emergency response number is different, it must be posted and publicized throughout the Navy or Marine Corps activity.

10.9 TRANSPORTATION ROUTES TO A MEDICAL FACILITY

A sketch indicating the route to the nearest medical facility/hospital (a good practice is to highlight the route with a yellow marker) should be included in the post-fall-arrest rescue plan) and should be posted at the job-site.

10.10 ANCHORAGES USED FOR RESCUE

a. Anchorages selected for rescue systems including control descent devices shall be capable of sustaining static loads applied in the direction permitted by the rescue system of at least 3,000 pounds when designed as a rescue system only. If the anchorage for fall-arrest system is selected as a rescue anchorage, it shall be capable of sustaining 5 times the foreseeable loads, applied in the directions permitted by the personnel fall-arrest system per attached person.

b. Anchorage connectors used for rescue shall not be attached to anchorages where such attachment would reduce the allowable capacity of the anchorage itself.

c. Anchorage connections shall be stabilized to prevent unwanted movement or disengagement of the rescue systems from the anchorage. The rescue system shall be load-tested before a live load is placed on the system.

d. The anchorage should be located at a point above the rescuer to prevent swing fall.

10.11 SELECTIVE RESCUE EQUIPMENT AND SYSTEMS

August, 2013

The following are some of the selective equipment that activities can use to rescue a person incapacitated at heights or has fallen and is suspended in a harness, or can be used to permit a person suspended in a harness to stand and allow the necessary circulation of blood while an assisted rescue is being commenced:

Self-Rescue and Assisted-Rescue Equipment:

- a. **Evacuation Harness.** Evacuation harness is used only for rescue and shall be designed to fit properly and securely to hold the rescue subject during rescue. The harness shall, at a minimum, provide support for the body around the shoulders and thighs.
- b. **Rescue Lanyard and Rescue Anchorage Connector Components** shall meet ANSI /ASSE Z359.4 Standard.



- c. **Self-Retracting Device with Integral Rescue Capability.** Self-retracting devices with integral rescue capability shall meet the requirements of ANSI Z359.4 and ANSI Z359.14, and shall be capable of engaging into the rescue mode of operation at any time. It shall not be possible to stop automatically and hold the load if the rescuer intentionally or unintentionally relinquishes control. The intent of this mode of operation is that the device will not inadvertently change to or from rescue mode. The minimum mechanical advantage offered by the equipment in rescue mode shall be 3:1, neglecting frictional losses.

August, 2013

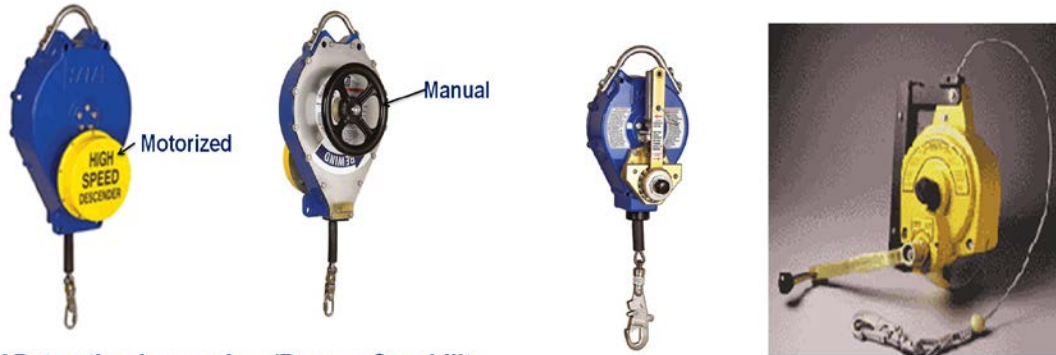

Self Retracting Lanyards w/Rescue Capability

Self Retracting Lanyard w/Winches for Rescue

- d. **Synthetic Rope Tackle Block.** The rope tackle block shall have shall have a minimum theoretical mechanical advantage of 3:1; and shall have a secondary means to prevent uncontrolled lowering of the worker. The rope used shall be made of synthetic material and shall have strength aging and abrasion resistance characteristics equivalent to or superior to polyamides.



- e. **Descent Devices.** Descent devices designed for single use shall have a minimum descent energy rating of 30,000 foot-pounds. Descent devices designed for repeated or multiple uses shall have a descent energy rating of not less than 300 foot-pounds. The descent speed for automatic descent control devices shall be not greater than 6.6 feet/second or less than 1.6 feet/second. For manual control devices and or hand operated the descent speed shall not exceed 6.6 feet/second.

10.12 REFERENCES RELATED TO RESCUE

- (a) OSHA Safety and Health Information Bulletin, SHIB 03-24-2004, updated 2011
- (b) OPNAVINST 5100.23H, Section 1312, Rescue Procedures

August, 2013

(c) NFPA 1670 Standard on Operations and Training for Technical Search and Rescue Incidents, 2009 Edition

(d) ANSI Z359: Fall Protection Code/Standards

(e) NAVMC DIR 5100.8, Marine Corps Occupational Safety and Health Program Manual

10.13 FALL-ARREST RESCUE PLANS

The Fall-arrest Rescue Plan should include the following Information as part of the Fall Protection and Prevention Plan:

- a. Provide a detailed location of the work site, with any information that will help find the location, building number, floor number; etc. Post written directions that can be read over the telephone to an ambulance driver/police/fire department, or their dispatchers, on how to get to the site from the main gate of a facility. Give complete, accurate information to the rescue responder. Post a map at the job-site, and highlight with a yellow marker, the route one should take from the site to the nearest hospital where someone with minor injuries can be treated expeditiously.
- b. Indicate the location of the lift or other equipment that will be used in case of emergency, and the location of the key.
- c. Provide the detailed location of the closest first aid kit. To assure that no time be lost looking for first aid kits during an emergency, post a site map marking the location of the first aid kits.
- d. List emergency telephone numbers. If an emergency rescue is required, call the telephone numbers in the order listed; i.e., 1st, 2nd, and 3rd. Post written directions that can be read over the telephone to an ambulance driver/police/fire department or their dispatchers on how to get to the site from the main gate of the facility. Give complete, accurate information to the rescue responder.
- e. Send an escort to meet the fire department upon arrival at the scene, and help them or the rescuer find the location of the accident.
- f. Give the name of the person (the escort designated to meet the fire department upon arrival at the scene) and the back-up person (in case the designated person is injured) responsible to make the phone call in case of emergency.
- g. Indicate names of personnel that may require rescue during the course of performing their jobs.
- h. If self-rescue is used, indicate the type of self-rescue equipment available at the job-site, or which will be utilized during rescue operations.
- i. Indicate the training the rescuer should receive in order to become a qualified rescuer.

August, 2013

k. Initiate a buddy system when personnel are working at heights and may require rescue. If the buddy system is not feasible, contact the activity to set up a visual or aural contact with the person exposed to Fall-Hazards every 15 minutes.

End of section

August, 2013

10.14 SAMPLE FALL-ARREST RESCUE PLAN FORM FOR FALL-HAZARD CONTROL

(Note: Local commands should use the following form format, making sure that they adhere to appropriate local regulations which may apply)

Date:

Site & Location Identification:

Detailed Location:

Primary Emergency Phone Number:

Type of Phone/Location:

Local Phone Line/Outside Line:

Secondary Emergency Phone Number:

Backup Rescue Lift is Available/Located at:

First Aid kit Location(s):

Fire Extinguishers locations(s):

Nearest Hospital Route and Location:

Procedure for requesting rescue and medical assistance:

Describe Rescue Operation and method:

Type of equipment used (PPE, Ladder, Hoist, etc.)

Training requirements:

Specialized Training for the rescuers:

Name of Personnel Requiring Rescue:

Self-Rescue Method and Equipment used:

August, 2013

For a person climbing alone, the name of the other person at the activity who will make visual or verbal contact with the end-user at least once every 15 minutes to assure that the user has not fallen.

Anchorage for rescue:

Pre-incident planning with jurisdictional public and Government emergency response agency:

Where work over water is planned, prepare a “Man Overboard” plan and attach as part of the rescue plan. (See Appendix D for a Sample Man Overboard Plan).

Additional Comments and Requirements:

Prepared by: _____

Approved by: _____

End of Section

August, 2013

10.15 Site-Specific Fall-arrest Rescue Plan (Checklist)

<u>GENERAL INFORMATION</u>			
Activity/Command:		Date:	
Building/Facility #:		Primary and secondary Phone Numbers:	
Detailed Location:		Ladder/Lift Location:	
First Aid Kit Location(s)	1.	Fire Extinguisher Locations:	1.
	2.		2.
	3.		3.
Nearest Medical Facility and Directions:			
Applicable Local Regulations or Requirements			
Procedure for Requesting Rescue	1.		
	2.		
	3.		
	4.		
Describe Rescue Operation and Method:			
Types of Equipment Used (Ladder, Hoist, Aerial Lift, etc.):			
If Self-Rescue or Assisted Rescue is Planned, Describe Equipment to be used			
Specialized Training for the Rescue Team:			
Describe if Additional Anchorages for Rescue are Required:			
Has Rescue Plan Been developed in coordination with Local Emergency Services (essential if relying on them to provide rescue)?			
Is a pre-Incident Plan prepared when the planned Method of Rescue is the Fire Department			
Additional Comments:			
Prepared By:			
Approved By (FPPM):			

End of Section

11.0 INSPECTION, MAINTENANCE, STORAGE, AND CARE PROCEDURES for PERSONAL FALL PROTECTION EQUIPMENT

As stated in 29 CFR 1910.66 Appendix C, Section I, Paragraph (f), personal fall arrest systems must be regularly inspected. **Any component of the system with significant defects must be removed from service immediately and shall be tagged or marked as unusable or destroyed.** All Fall Protection equipment shall be inspected before each use by the user and by a Competent Person at intervals of no more than one year or as prescribed by the manufacturer of the equipment. **Most manufacturers recommend inspection of the equipment to be conducted twice annually by the Competent Person.** Inspection of the equipment by the Competent Person shall be documented and the tag on the equipment shall be checked and dated by the Competent Person on the date of inspection. All components and sub-components of the selected fall-arrest, positioning, and restraint systems shall be compatible.

As a general rule, always consult equipment manufacturers' instructions and recommendations for use, inspection, care and maintenance procedures.

Inspect personal FP equipment for the following defects:

- (1) **Webbing and ropes (Harnesses, Lanyards, straps, etc.):**
 - **Look for cuts, wear, tears, damaged threads, broken fibers, undue stretching, torn or pulled stitches, frayed edges, mold, alterations, or additions which will affect its efficiency, damage due to deterioration, chemical damage (contact with fire, acids, or corrosives), abrasions, ultraviolet deterioration and missing markings and labels, and any wearing or internal deterioration of the ropes.**
- (2) **Hardware (Snap-hooks, Carabiners, Connectors and D-rings):**
 - **Look for distorted hooks or faulty springs, tongues unfitted to the shoulder buckles, loose or damaged mountings, nonfunctional parts, check for signs of excessive wear, crack, corrosion and deformation.**

Note: for Fall Protection Equipment Inspection Checklist see Paragraph 11.3.

11.1 SPECIFIC EQUIPMENT INSPECTION

11.1.1 ANCHORAGE SYSTEMS (anchorages and anchorage connectors):

- a. **Inspect all components of the anchorage systems.**

August, 2013

- b. Observe any abrasions, wear points, damaged threads, or sags in the sling material before use.
- c. For synthetic slings and anchor straps inspect all sewing and loops for wear, chemical damage, burn damage, and/or ultraviolet deterioration.
- d. Refer to the anchorage-attached tags to determine when the sling should be retired.
- e. Inspect cable slings for excessive damage to the steel fibers.
- f. Certify the anchorage system exposed to weather or corrosive conditions.
- g. Inspect anchorage connectors for integrity and attachment to solid surfaces.

11.1.2 SNAPHOOKS AND CARABINERS

- a. Inspect on a regular basis and before each use.
- b. Inspect snaphooks and carabiners for any hook, locks and eye distortion.
- c. Verify that there are no cracks, pitted surfaces, and eye distortions.
- d. The keeper latch must not be bent, distorted, or obstructed.
- e. Verify that the keeper latch seats into the nose without binding.
- f. Verify that the keeper spring securely closes the keeper latch.
- g. Test the locking mechanism to verify that the keeper latch locks properly.
- h. Verify that the points where the lanyard attaches to the snaphooks are free of defects
- i. Retire snaphooks, carabiners, and all integral components if any discoloration, deformation, cracks, or abrasions are detected.
- j. Retire immediately if the item has sustained any fall, or if the spring is broken and gate is bent, or if the gatekeeper no longer engages the slot cleanly.
- k. Damaged snaphook and carabiners shall be tagged and removed from service and from the inventory list.
- l. Dirty snaphooks and carabiners shall be cleaned with kerosene, WD-40 (or equivalent), or similar solvents, and immersed in boiling water for 30 seconds to remove the cleaning agent. Dry with a soft cloth to ensure that the gate and gatekeeper operate properly.
- m. Ensure that only double-locking-type gates are used.

11.1.3 LANYARDS AND ENERGY ABSORBERS

- a. Inspect lanyards put under a slight tension on a regular basis.
- b. Check all components for abrasion, cuts, discoloration, cracks, burns, knots, torn stitching and excessive wear.
- c. Visually inspect the energy absorber for any signs of damage, paying close attention to where the energy absorber attaches to the lanyard.
- d. Wash lanyards and energy absorbers on a regular basis to remove dirt and grit, which can abrade the fibers.
- e. Lanyards and energy absorbers shall have a permanently attached label indicating the manufacturer's name, serial number or lot number, date of manufacture, maximum elongation, maximum arresting force, maximum free-fall, and capacity. The lanyards and energy absorbers must also have permanently attached labels that indicate they meet OSHA & ANSI Z359 FP Code/Standards and requirements. Lanyards bearing the markings of ANSI A10.14 (only) are not acceptable and they shall be taken out of service.
- f. Use and review manufacturer's logbook provided with the equipment to determine the age of the lanyard and energy absorber.

August, 2013

- g. Lanyards and energy absorbers shall be inspected by the user prior to each use and by a Competent Person other than the user at least once a year.
- h. Check for missing marking and labels.
- i. Maximum usage of a lanyard shall not be more than 5 years, unless the Competent Person for Fall Protection carefully inspects it, review its history of use and storage, and recommends its continued use, once put in service (assuming the new unused lanyard is stored in a climate-controlled location, [i.e., in a plastic bag not exposed to fumes, and in a cool location out of direct sunlight]).

Retire the lanyard:

- (1) After a hard fall.
- (2) When the shock absorber (even if slightly) is impacted or deployed.
- (3) If the lanyard has been used for any other purpose other than Fall Protection.
- (4) If the equipment show excessive wear, chemical damage, burn damage, and/or ultraviolet deterioration.

11.1.4 FALL-ARRESTOR (ROPE GRAB)

- a. Inspect regularly.
- b. Check for signs of wear, corrosion, rust, and other anomalies.
- c. If any sign of wear or malfunction is observed, remove the device from service immediately.

11.1.5 SELF-RETRACTING DEVICES

- a. Inspect before each use for any physical damage.
- b. Inspect by a Competent Person once every six months and by the manufacturer annually.
- c. If the Self-retracting Device housing becomes yellow, gathers condensation, or the indicator has been engaged, remove it from service immediately, and return it to the manufacturer for repair and re-certification.
- d. SRDs shall have permanently attached labels indicating that they meet ANSI Z359.14 and OSHA Standards and requirements.
- e. Make sure that all back nuts or rivets are tight
- f. Make sure that the entire length of the nylon strap is free of any cuts, burns, abrasions, kinks, knots, broken stitches, and excessive wear, and retracts freely.
- g. Test the unit by pulling sharply on the lanyard to verify that the locking mechanism is operating correctly.

ADDITIONAL DISCUSSION

SRDs should be briefly inspected prior to each use, and more thoroughly inspected by a CP regularly. With specialized training it is possible that a CP can become certified to conduct re-certification and general services. Usually, SRDs are returned to the manufacturer for service and recertification. Any equipment with many movable mechanical components or parts requires specialized inspection. Usually the CP does not have the tools, equipment and/or qualification to conduct such inspection.

August, 2013

In order to determine if the SRD is in good and safe working condition, specialized testing and inspection must be conducted on the SRD. This includes opening the casing, inspecting the inner components of the SRL and the drum containing excess spooled line, inspecting the locking mechanism, spring, connecting means, and fall indicator, and corrosion inspection in special environments. This is the why only the manufacturer can inspect and certify the SRD.

SRDs are designated as Repairable or Non-repairable:

Repairable Self-retracting Devices shall be returned to the manufacturer for servicing and re-certification (Factory authorized inspection) depending on the type, usage and the environment, in accordance with the following Inspection Requirements table:

TYPE OF USE	APPLICATION	CONDITION OF USE	INSPECTION FREQUENCY BY COMPETENT PERSON	FACTORY AUTHORIZED INSPECTION
Infrequent or minimal usage	Used in rescue, confined space, industrial maintenance	Good Indoor Storage or Minimal Outdoor Use	Semi Annually	At least every 2-5 years
Moderate to Heavy Use	Transportation , Construction, Utilities and Warehouses	Moderate storage Conditions, indoor and extended outdoor usage, all temperature or dusty environment	Semi Annually	At least every 1-2 years
Continuous usage to severe conditions	Heavy Construction and industrial use, Shipyard environment	Harsh storage conditions, continuous outdoor use, all temperatures, dirty environment	Quarterly to semi annually	At least annually

All Factory Authorized Inspections of all Self-retracting Devices shall not be less frequent than the intervals required by the manufacturer.

For repairable SRDs, not requiring factory authorized inspections by a manufacturer would be considered non compliant with ANSI standards.

Non Repairable SRDs are designed and designated as Non-Repairable (not designed for disassembly). They are very basic in design and limited in length and use, made of synthetic webbing. Complete internal inspection is not possible without destroying or damaging the device. The competent person for fall protection shall work with written manufacturer's inspection requirements to determine whether the device can be used or not. If the inspection is not possible, the device shall be taken out of service. The contrast of the device being used inside or outside would affect the term of its use dramatically.

11.1.6 BODY SUPPORT (FULL-BODY HARNESS)

- a. Inspect daily or before each use.
- b. Inspect thoroughly and verify that there are no torn, frayed, broken fibers, pulled stitches, or frayed edges, anywhere on the harness
- c. Closely examine all of the nylon webbing to ensure there are no burn marks from welding or heat sources, which could weaken the material
- d. Examine D-ring for excessive wear, deterioration, or cracks.
- e. Verify that buckles are not deformed, cracked, and will operate correctly.
- f. Check to see that all grommets (if present) are secure and not deformed from abuse or a fall.
- g. Check tongue/straps for excessive wear from repeated buckling.
- h. All rivets must be tight, not deformed.
- i. Inspect for missing markings and labels.
- j. Ensure that harnesses are not painted or marked.
- k. Examine the harness for discoloration, abrasions and ultraviolet deterioration.
- l. Store harnesses in a cool, dry, and safe environment; ideally in a locked storage area
- m. A Competent Person other than the user shall inspect the harness periodically, or at least once a year.
- n. Wash the harness in a mild soap and rinse multiple times to remove any soap residue, and hang to dry out of direct sunlight in a cool, dry environment.
- o. Maintain a logbook indicating the date of entry into service, the nature of the work performed, washing of the harness, or other relevant details.
- p. Retire harnesses from service after five years from the date put into service (assuming the new unused harness is stored in a climate-controlled environment [i.e., in a plastic bag not exposed to fumes, and in a cool location out of direct sunlight]) unless the Competent Person for Fall Protection carefully inspects it, reviews its history of use and storage, and recommends its continued use.
- q. The body support harness shall have a permanently attached label indicating manufacturer's name, serial number or lot number, date of manufacture, capacity, and that it meets OSHA & ANSI Z359 Fall Protection Code/Standards requirements.

11.1.7 ROPES (SYNTHETIC FIBERS)

August, 2013

- a. Inspect rope periodically for broken fibers, severely worn areas, or change in the consistency of the core; inspect under slight tension and check for soft areas, bulges, or excessive stiffness.
- b. Avoid exposing rope to hazardous chemicals, moisture, acids, or oils.
- c. Do not use the rope after it is impacted or damaged.
- d. Wash the rope on a regular basis with lukewarm water and mild detergent to remove dirt or grit, rinse several times to remove soap residue, and hang in a dry, cool, dark area.
- e. Store rope in a strong weatherproof bag. Rope always must be dry before being placed in storage.
- f. Rope shall have a permanently attached label indicating manufacturer's name, serial number or lot number, date of manufacture, capacity, and that it meets OSHA & ANSI Z359 Fall Protection Code/Standards requirements.
- g. Retire rope after five years of service unless the Competent Person for Fall Protection carefully inspects it, reviews its history of use and storage, and recommends its continued use. If it is damaged, impacted, or exposed to chemicals, remove from service immediately.
- h. Avoid the use of Kern-mantle ropes.

11.1.8 SINGLE ANCHOR VERTICAL LIFELINES (FLEXIBLE)

Refer to section 11.1.7 above and manufacturer's recommendations regarding inspection, care, and maintenance.

11.1.9 CLIMBING LADDER FALL ARREST SYSTEM

- a. Inspect on a regular basis per equipment manufacturer's requirements.
- b. The sleeve must run freely without hand operations or guidance.
- c. Check cable and rails for abrasions, wear, looseness, and cracks.
- d. Before climbing, check integrity of cable, system, and ground level.

11.1.10 RAISING/LOWERING DEVICES (RESCUE)

- a. Inspect before each use.
- b. Check for wear and corrosion.

11.1.11 HORIZONTAL LIFELINE

- a. Inspect the system including anchorages, anchorage connectors, cable and other hardware for defects or loose or components similar to inspection of other fall-arrest system components.

The end-user shall inspect the components of the system prior to each use. **Type 1 HLL system**, the Competent Person for Fall Protection shall inspect the system at an interval of no more than one year under the direction of a Qualified Person for Fall Protection. **Type 2 HLL System** shall be inspected once a year by the Competent Person for Fall Protection who is trained by the manufacturer of the system to perform such inspections and under the direction of the Qualified Person for Fall Protection.

August, 2013

11.2 ADDITIONAL INSTRUCTIONS FOR ASSEMBLY, DISASSEMBLY, STORAGE, INSPECTION, CARE AND MAINTENANCE

(a) Protect against cuts and abrasions:

All safety lines and lanyards shall be protected against cuts or abrasions. Padding must be used wherever sharp edges exist.

(b) All safety lines and lanyards shall be stored in an approved location, as follows:

All Fall Protection/restraint equipment shall be stored in a weatherproof container or locker when not in use. Equipment should not be allowed to lie in water or direct sunlight, since this will affect equipment strength. Never store personal fall-arrest equipment in the bottom of a tool box, on the ground, or outside exposed to the elements (i.e., sun, rain, snow, etc.).

(c) The fall-arrest system components shall be compatible, as follows:

Contact the qualified or Competent Persons for Fall Protection or manufacturer's representative for assistance. In the use of fall-arrest systems, all components shall be designed for use with each other, or approval must be obtained from the manufacturer or Qualified Person to use the configuration that uses different components. All system components shall be compatible.

(d) Follow the manufacturers and the Qualified Person's instructions for installation, assembly/disassembly, and use, as follows:

All systems must be installed, assembled, and disassembled per the manufacturer's direction. Failure to follow these instructions could lead to the possible failure of a system.

(e) In the event of a fall, secure all equipment involved and contact the Safety Officer for disposition. Do not reuse safety equipment that has experienced a fall:

In the event of a fall, the first response is to ensure the safety of the employees. After rescue and, if required, medical aid is provided, all equipment involved must be removed from service. The Navy or Marine Corps activity Safety Office must be contacted.

For Fall Protection equipment inspection check list and system check list, see Paragraph 11.3.

(f) During inspection of the equipment by the competent person for fall protection, only mark on the labels. Some manufacturers permits the use if certain types of permanent markers which are water resistant and quick- drying such as Sanford Sharpi Permanent Markers.

(g) Care and Maintenance of the Equipment:

August, 2013

Snaphooks and Carabiners: Clean dirty gates of snaphooks and carabiners by applying WD-40 (or equivalent), other solvents, oil, or kerosene, until the gates work smoothly, than immerse in boiling water for 20-30 seconds to remove cleaning agent; dry with a soft cloth to ensure that the gate and gatekeeper operate properly.

Harnesses, Lanyards and Ropes: Wash on regular basis with mild soap and rinse multiple times to remove the soap residue, store in a cool dry and safe environment to dry. Ensure harnesses and lanyards are not painted or marked. Mark only on labels.

Note: Always consult manufacturer's instructions and recommendations for care and maintenance of the equipment.

End of Section

August, 2013

11.4 FALL-ARREST SYSTEM AND EQUIPMENT CHECKLIST

(Must answer yes to all applicable questions)

Prepared either by the Competent Person or a person trained and designated by the Competent Person for Fall Protection.

11.4.1 ANCHORAGES

1. Do workers know appropriate anchorage points for each task that requires a fall-arrest/positioning or restraint system? _____
2. Are all anchorage points stable, substantial, and have sufficient strength to withstand twice the potential impact energy of the free-fall? _____
3. Is the "D" ring of the full-body harnesses located at the back shoulder height? _____
4. Are anchorage points for self retracting lanyards located overhead? _____
5. Can the employee move from one station to another or climb up and down without exposure to a fall? _____
6. If the lifeline, lanyard, or self retracting device is not permanently attached to an anchorage point at the elevated work area, is the first worker up or the last worker down protected while climbing and traversing? _____

11.4.2 LANYARDS

1. Is the lanyard length as short as necessary and in no case greater than 6 feet?
2. Are manually adjustable lanyards used when it is desirable to be able to take slack out of the lanyard? _____
3. Does the lanyard have a shock-absorbing feature to limit the arresting forces? _____
4. If the lanyard has a shock absorber, is it obvious to the user that the shock absorber has been deployed? (Is there a warning label, broken pouch, deployment indicator, etc.) _____
5. Are knots from the lanyard to the lifeline clearly prohibited? (Mechanical rope grabs or fall-arresters must be used) _____

August, 2013

11.4.3 SELF-RETRACTING DEVICES (SRDs)

1. Are employees properly trained to use a SRD? _____
2. Is the SRD under a regular maintenance and inspection program? _____
3. Is the end of the cable properly spliced _____ (Thimble eye, Flemish eye-spliced, and swaged fitting/ferrule)?

11.4.4 SNAPHOOKS

1. Have double-locking snaphooks been used? _____
2. Is the snaphook attached to the D-ring, hoist ring designed for construction applications, or other hardware in a manner approved by the manufacturer of the snaphook? _____
3. Are snaphooks inspected regularly for stress, wear, distortion, and spring failure? _____
4. Are snaphooks arranged so they are never connected to each other? _____ (They should NOT be connected to each other).

11.4.5 FULL-BODY HARNESES

1. Are full-body harnesses selected for a particular job quipped with all necessary attachment points? (For fall-arresting, work positioning, descent control, rescue, or ladder fall-protection systems) _____
2. Are body harnesses inspected regularly for wear, abrasion, broken stitching, and missing hardware? _____
3. Is the Velcro type of closure prohibited from all load-bearing connections? _____
4. Have workers been instructed in the use and care of body harnesses? _____
5. Is the harness equipped with lanyard parking location for attaching the unused leg of the "Y" lanyard? _____

11.4.6 FALL-ARRESTERS

1. Is the fall-arrester compatible with the lifeline on which it is to be installed or operated? _____
2. Is the fall-arrester in operational condition? _____

August, 2013

3. Is the fall-arrester equipped with a changeover lever that allows it to become a stationary anchor on the lifeline? _____
4. Is the fall-arrester equipped with a locking mechanism that prevents unintentional opening of the device and subsequent disengagement from the lifeline? _____
5. Is the fall-arrester's "up" direction marked properly so that the equipment can be attached to the line correctly? _____

11.4.7 SINGLE ANCHOR VERTICAL LIFELINES

1. Does the lifeline have a minimum breaking strength of 5,000 pounds (2,268 kilograms)? _____
2. Is the lifeline protected from abrasive or cutting edges? _____
3. Does the system provide Fall Protection as the worker connects to and releases from the lifeline? _____
4. Is the lifeline arranged so workers never have to hold it for balance? (A lifeline should never be used for balance) _____
5. Is the vertical segment integrated with the horizontal segment to provide continuous Fall Protection? _____
6. Is the fall arrestor used with single anchor vertical lifeline equipped with energy absorber? _____
7. Is the fall arrestor used with single anchor lifeline automatic? _____

11.4.8 HORIZONTAL LIFELINES

1. Has the entire horizontal lifeline system been designed, approved and certified by a Qualified Person for Fall Protection? _____
2. Have the anchorages to which the lifeline is attached been designed and evaluated specifically for a horizontal lifeline? _____
3. Has the designer of the system approved the number of employees who will be using it? _____
4. Is the rope or cable free from signs of wear or abrasion? _____
5. Does the rope or cable have the required initial sag? _____

August, 2013

6. Have the workers been warned about potential falls? _____
Have the clearances been checked? _____
7. Is the hardware riding on the horizontal lifeline made of steel? (Aluminum is not permitted because it wears excessively) _____
8. Is the fall-arrester included in a regular maintenance and inspection program?

11.4.9 OTHER CONSIDERATIONS

1. Has the free-fall distance been considered, so that a worker will not strike a lower surface or object before the fall is arrested? _____
2. Have pendulum-swing Fall-Hazards been eliminated? _____
3. Have safe methods to retrieve fallen workers been planned? _____
4. Is all fall-arrest equipment free of potential damage from welding, chemical corrosion, or sandblasts? _____
5. Are all components of the system compatible according to the manufacture's instruction?

6. Have employees been properly trained in the following issues?
Manufacturer's recommendations, restrictions, instructions, and warnings _____,
Location of appropriate anchorage points and attachment techniques _____
Are there any problems associated with elongation, deceleration distance, and method of use, inspection, and storage? _____
7. Are all regular inspections performed by trained inspectors? _____
8. Are written reports maintained? _____
9. Has the total fall distance been considered? _____
10. Has rescue of the worker been considered? _____

End of section

12.0 TIE-OFF CONSIDERATIONS AND SELECTION OF SAFE ANCHORAGES

12.1 One of the most important aspects of personal fall-arrest is fully planning the system before it is put in use. Probably the most overlooked component of the fall-arrest system is planning for suitable anchorages. Such planning should ideally be done during the design stage and before a structure or a building is constructed so that anchorages can be incorporated and identified during construction for maximum use later for maintenance work. If needed, properly planned and designed, these anchorages used during construction work may also be used afterward during maintenance.

12.1.1 The strength of a personal fall-arrest system depends on its subsystems and components, as well as the anchorages and how strongly such a system is attached to the anchorage. Such attachment shall not significantly reduce the strength of the system, including the structural members (e.g., the beams or columns to which it is attached). If a method of attachment is used that will reduce the strength of the system, such component (e.g., beam or column) shall be replaced with a stronger one in order to maintain the appropriate maximum characteristics in compliance with IBC and design criteria documents.

12.1.2 Lanyards shall not be connected to themselves or to other lanyards unless permitted by the manufacturer.

12.1.3 Knots shall not be tied in lanyards, lifelines, or anchorage connectors (i.e., anchor straps). Tie-off using a knot in a lanyard, lifelines, or anchorage connectors can reduce the strength by 50% or more.

12.1.4 Tying a rope lanyard or lifeline around rough or sharp edges such as beams, columns or other surfaces may reduce the strength of the line due to cutting action of the sharp edge. If a line is cut or damaged, it will drastically affect the design reaction of the system during a fall. Such tie-off should be avoided or alternate rigging method should be used. As an alternate, use beam clamp, wire rope, effective padding, or abrasion-resistance strap (chaffing protection) around or over the sharp or rough surfaces.

12.1.5 The anchorage location should be as high as possible to minimize the free-fall distance and prevent any contact with an obstruction or the ground below if a worker falls. Free-fall distance shall not exceed six feet unless a specially designed lanyard is used that will allow the 12 foot free-fall provided the maximum arresting force does not exceed 1,800 pounds. The anchorage point height shall reflect this restriction.

12.1.6 Tie-off point(s) shall be located in such a way to minimize the swinging of the worker (pendulum-like motion) that can occur during a fall. The farther away in a horizontal direction a worker moves from a fixed anchorage (tie-off point), the greater the swing angle if a fall occurs. If any obstruction exists in the path of the swing fall, the force

August, 2013

generated can be significant. The maximum angle of swing away from the tie-off point should not be more than 15 degrees in either direction.

12.1.7 The strength of an eyebolt is rated along the axis of the bolt and its strength is greatly reduced if the force is applied at an angle to this axis (out-of- the-plane of the eye). Also, the diameter of the eyebolt should be compatible to snaphook or carabiner attachment. Non-rotating rings should be avoided, since falls rarely occur directly along the axis of the eyebolt. Where possible, rotating rings (swivel rings) with full motion in the three axes should be used to increase the angle with the axis to more than 45 degrees. The ring will then be able to automatically align along the direction of force. Swivel rings used as anchorages in a fall arrest system shall be properly sized. The eyebolt used in the fall protection system shall be forged steel. Effort shall be made to minimize the angle between the axis of the eyebolt and the direction of the pull.

12.1.8 Attaching two snaphooks to the same anchorage:

a. Where two employees are planning to use the same anchorage simultaneously by using two snaphooks, the anchorage must be certified and rated for use by two people. Connecting both snaphooks to the anchorage will require the use of additional connector.

12.1.9 Horizontal lifelines, depending on their geometry and angle of sag, may be subjected to greater loads than the impact load imposed by an attached component. When the angle of sag for the horizontal lifeline is less than 30 degrees, the impact force generated is greatly amplified. For example, with a sag angle of 15 degrees, the force amplification is about 2:1 and at 5 degrees sag, it is about 6:1. Depending on the angle of sag, and the line's elasticity, the strength of the horizontal lifeline and the anchorages to which it is attached should be increased a number of times over that of the lanyard. Extreme care should be taken in considering a horizontal lifeline for multiple tie-off. The reason for this is that in a multiple tie-off to a horizontal lifeline, if one employee falls, the movement of the falling worker may cause other employees to also fall. Horizontal lifeline and anchorage strength should be calculated for each additional employee to be tied-off. For these and other reasons, horizontal lifelines shall only be designed, selected, and certified by Qualified Person for fall protections. Inspection of installed horizontal lifelines and anchors before use is recommended.

The following are some considerations when evaluating horizontal lifeline systems:

- a. Review the design calculations of the system;
- b. Review manufacturer's test data of similar systems

12.1.10 The anchorage and anchorage connector shall be compatible.

12.1.11 When tying off to a beam or column, do not attach the anchorage connection to a hole in the beam unless evaluated by a Qualified Person for Fall Protection, because the forces generated by a fall will weaken the beam structure. Do not drill a hole for tying off. This attachment will weaken the beam. The most favorable way to tie-off is to use an

August, 2013

anchorage connection to wrap around the beam or column, such as an anchor strap, or use a designed beam clamp.

12.1.12 Do not tie a knot in the anchorage connection.

12.1.13 The most favorable location to tie-off to a beam is in the center of the span. This action will distribute the forces evenly at the supports. The closer the tie-off point is to the beam support, the shear-force of a fall on the structure will increase accordingly. However, when tying-off to the beam always consider the hazard of swing fall effect.

12.1.14 Take into consideration the impact of shear forces at the supports and the bending moment distribution of forces beyond the supports into other structural members.

12.1.15 In the selection of a point of anchor in a column, take into consideration the effect of all forces due to axial loading and bending stresses.

12.1.16 Refrain from welding the anchorage connection to the anchorage, unless the welding is performed and certificated annually by a certified welder.

12.1.17 Where nails are used to install roof anchors, the number, type, and size of nails used to attach the component to a wood structure shall be in accordance with the building code requirements. Verify that the roof anchors are attached to structural members, rather than decking only.

12.18 Always specify the number of end-users that are allowed to attach to a specific anchorage.

12.1.19 In selection of anchorage location, take into consideration the accessibility and ease of securing or attaching to it (ease of tying off).

12.1.20 In attachment of the fall-arrest system to a concrete slab, make sure the concrete is strong and thick enough to sustain the static and dynamic loads of the fall forces. The bottom steel reinforcement in the concrete slab most usually is in tension. Concrete alone is very weak under tension.

12.2 Fall-Arrest System Considerations:

- Prior to selecting a fall arrest system, the following information should be verified and considered:
 - Movement of the worker;
 - Existing obstructions in the worker's path;
 - Location and availability of safe anchorages;
 - Total fall distance, free fall distance and available clearance;
 - Possibility of swing fall hazards;
 - Compatibility of all components of the system;

August, 2013

- Impact forces;
- Availability of rescue/self rescue.

End of Section

13.0 RESPONSIBILITY FOR DESIGN, INSPECTION, CERTIFICATION, and RE-CERTIFICATION of ANCHORAGES

Anchorage can be either engineered or improvised. An anchorage system is a combination of anchorage point and anchorage connector(s). Improvised fall-arrest anchorages and anchorage connectors shall withstand a force of 5,000 pounds for every person attached to the system. Positioning anchorages shall withstand a force of 3,000 pounds and restraint anchorages shall withstand a force of 1,000 pounds (Per ANSI Z359.2 standard). Anchorage connectors are usually designed and prefabricated by a manufacturer under the supervision of a Qualified Person, and meet OSHA and ANSI standards. The certification and re-certification of anchorage connectors can be performed by the manufacturer or Qualified Person.

13.1 RESPONSIBILITY OF ANCHORAGE IDENTIFICATION, DESIGN, AND CERTIFICATION

a. **Anchorage should be designed before use by a registered professional engineer with experience in designing fall-protection systems, and installed by person(s); or another Qualified Person with appropriate education and experience should design the anchor point to be installed. If an anchor point from existing structures such as beams, or hoist ring designed for construction applications, is needed, a Qualified Person for Fall Protection should be used to evaluate these anchorages.**

b. **Fall-arrest system anchorages shall be capable of supporting 5,000 pounds per employee attached; or the anchorages shall be designed, installed, and used under the supervision of a Qualified Person for Fall Protection for twice the maximum arrest force as part of a complete fall-arrest system.**

c. A Qualified Person for Fall Protection should be able to calculate the forces generated by arresting a fall; total loading; impact on the structural members the line is attached to; and determine the optimal and safe location where and how to tie-off. The Qualified Person should have the knowledge and be capable of designing, certifying, supervising, approving, and rating the anchor points and tie-off points.

Contact a Qualified Person for Fall Protection for anchorages loading, selection and approval:

Due to the variability in the structural strength of different materials, before using an anchorage point, a Qualified Person for Fall Protection must be contacted to ensure that the anchorage meets/exceeds regulatory requirements.

August, 2013

d. For recertification of active Fall Protection systems, the Qualified Person or the engineer of record shall specify the frequency of re-certification, but not to exceed five years.

13.2 INSPECTION, CERTIFICATION AND RE-CERTIFICATION OF ANCHORAGES

a. **Inspection:** Fall-arrest, positioning, and restraint equipment shall be inspected by the user before each use, and by a Competent Person annually, and in accordance with the manufacturer's instructions. Workers are not qualified to inspect anchor points; however, they should be trained to pay special attention to any cracks developing around the anchor points, or if the anchor points are unstable or loose. End-users shall not tie-off to unsafe anchorages and they should bring it to the attention of the Competent Person for Fall Protection if such a situation exists. The manufacturers of the Fall Protection equipment/systems shall indicate in the supplied manufacturer's instructions the methods of inspection and durations. Any components of the system not addressed by the manufacturer's inspection requirements (e.g., anchorages), shall be visually inspected in a manner and frequency specified by the design engineer.

b. **Certification and Re-Certification of Anchorages:** Anchorages should be field-verified by a Qualified Person for Fall Protection. ANSI Z359 Fall Protection Code/Standards addresses certification of anchorage connections. It does not address certification of anchor points. A registered professional engineer or a Qualified Person for Fall Protection can certify the structural integrity of the anchor points. Depending on the design, type, location, and the size of the structural member to which the anchorage is connected, the environment and weather conditions dictate how often such anchorages shall be inspected and re-certified by a Qualified Person for Fall Protection.

c. **Recertification of Fall Protection System:** The design of FP system shall be thoroughly reviewed by an engineer who is qualified in designing FP systems. The original design of the system should have indicated the frequency of the recertification criteria. **The period of recertification shall not exceed five years.** Recertification process shall include:

- (1) Review of the original design;
- (2) Any changes in the hazards or tasks performed;
- (3) Changes in regulations or standards;
- (4) Any other factors affecting the system.

d. **Qualification and Verification Testing of Fall Protection Equipment:** Navy or Marine Corps activities shall use personal Fall Protection equipment where manufacturers can substantiate through Third Party Testing laboratories, Witnessed Testing by a Professional Engineer, or Manufacturer Self-Certification testing, and that the equipment meets the requirements addressed in ANSI Z359 Fall Protection Code/Standards.

To ensure conformity of the equipment with Z359 Fall Protection Code/Standards, testing laboratories performing compliance testing on fall protection

August, 2013

equipment/products shall be accredited by an outside accreditation bodies accredited to ISO 17011 standard titled “General Requirements for Accreditation Bodies Accrediting Conformity Assessment Bodies, and ISO 17025 General Requirements for the Competence of Testing and Calibration Laboratories.

e. Certified Vs Non Certified Anchorages

Definitions:

- **Certification:** The act of attesting in writing that the criteria established have been met.
- **Certified:** An act or process resulting in documentation attesting that the criteria and requirements of Z359 Standards has been met. Such act may be carried out by testing or applying proven analytical method or both under the supervision of a qualified person for fall protection.

Anchorage System consists of anchorage and anchorage connector. Fall Protection regulations and standards require anchorages to withstand a force of 5,000 pounds per person or designed by a qualified person for fall protection for twice the maximum arrest force; these are unquestionably strong elements of the building, structure or equipment. Anchorages could be a beam, column or any rigid part of the building or structure

- **Certified Anchorages** are anchorages capable of supporting the potential fall forces, which is designed and certified by or under the supervision of a qualified person.
- **Non-Certified Anchorages** are anchorages selected by a Competent Person for Fall Protection that he can judge to be capable of supporting the fall forces as prescribed by ANSI Z359 Standards.

End of Section

14.0 FALL PREVENTION CONSIDERATIONS **DURING PLANNING AND DESIGN PHASE**

14.1 INTRODUCTION: When planning and designing new buildings or facilities, DON planners and designers, including owners/managers of such facilities, are responsible for providing safe design for the protection of all workers and users exposed to the hazards of fall from heights during performance of their work. DON architects and engineers or any other entity planning or designing a building, structure, or facility, including integral assemblies such as weight-handling equipment (cranes, hoists, etc), have the general duty and responsibility to have a safe design for preventing falls throughout the facility. This duty extends to any person who may be involved in the construction, demolition, modification, renovation, maintenance, or normal work operation of the building, structure, or facility.

a. DON architects and engineers need to be aware that any part of a building, facility, structure, equipment, and integral assemblies such as weight-handling equipment (cranes, hoists, etc), will require maintenance work. If such work is required, prevention and control measures should be incorporated into the design to eliminate and prevent the need to work at height with its subsequent exposure to Fall-Hazards.

b. **Architects, engineers, designers, construction managers, superintendents, contractors/subcontractors, and owners of buildings and facilities have a major role and are responsible for creating a safe work environment and being aware of Fall-Hazards. They shall have the proper knowledge and awareness of Fall-Hazards that will be encountered at the workplaces they are designing, constructing, occupying, and operating.**

c. **Fall prevention philosophy for designing new buildings and facilities:** Fall-Hazards should be designed out of new buildings, facilities or structures. When Fall-Hazards cannot be eliminated or prevented, designers should provide alternative remedies such as identification and installation of anchorages (hard points).

Any location or part of a building, structure, facility or equipment will one day require, either, maintenance, remodeling, modification or replacement work. Engineers and architects should design new buildings and facilities with this idea in mind.

d. **Fall Prevention during Design for Engineers and Architects**

Falls from height are a major cause of work related injuries and fatalities. Engineers, architects, designers and planners are responsible for designing safe buildings, facilities, structures and equipment. They should strive to eliminate, minimize or prevent the hazards of falling at work places. During construction, potential hazards should be identified and preventive measures should be incorporated in the design to

August, 2013

assist contractors building the project in a safe manner. Post construction, the facility should protect personnel during normal work operations and help maintenance personnel conduct their work safely and without exposing them to Fall-Hazards.

e. Applicability of Fall Protection Requirements to Architects and Engineers:

OPNAVINST 5100.23 Series, Paragraph 1311.b states:” Fall-arrest anchorages in new facilities, buildings and structures. During the design of new facilities, buildings, and structures, Fall-Hazards should be considered and eliminated whenever possible. When elimination of Fall-Hazards is not feasible, the design should include certified and labeled anchorages”. Additionally, the new ANSI Z359.2 Standard, require architects and engineers to include Fall Protection systems in the design of new facilities.

- f. Architects and engineers are required to be trained in fall prevention in accordance with OPNAVINST 5100.23 Series, Appendix 13-A, and Section 6.1.9 of this guide.

14.2 PLANNING AND DESIGN CONSIDERATIONS: It is very important at the design and planning phase to give consideration to the prevention of falls, not only during construction, but subsequent use, or maintenance of the building, structure, or facility. Consideration during various phases includes the following:

a. Construction Phase:

- (1) Reducing the risk when working at heights (e.g., installation of guardrails to the perimeter structural members prior to erection).
- (2) Reducing the need to work at heights as much as possible by prefabricating modules on the ground before lifting them into position.
- (3) The placement and condition of the access road leading to the building or facility during construction, for example, which would enable a crane to place building material in the most appropriate and accessible location.
- (4) Preparation and/or clearing debris on the ground or floor below the work area. The ground should be compacted and leveled in order to prevent tilting, unstable equipment (e.g., cranes or scissors lifts). All trenches or holes at the work site shall be guarded adequately to prevent aerial work platforms or other equipment from falling into such hazards.
- (5) Provision of temporary safety mesh as much as possible to prevent objects from falling down to lower levels.

b. Maintenance and Occupancy Phase:

- (1) Safe access to or egress from any work area.
- (2) Provision of permanent guardrails or edge protection such as parapets.
- (3) Selection of material that can withstand a harsh environment. (e.g., special wood planks such as particleboard can weaken due to moisture absorption, thereby not supporting the weight of a worker during a future roofing inspection or maintenance work).

August, 2013

- (4) Use of temporary work platforms whenever possible, such as scaffold, and elevating work platforms.
- (5) Identification and location of services (e.g., location of power lines, water, etc.).
- (6) Location and operations of type of equipment selected and devices used (e.g., using adjustable light fixtures that can be lowered to the ground for replacement).
- (7) Use of fall-arrest systems and devices, including the provision of suitably located temporary or permanent anchor points and field identification of all required anchorage points.
- (8) Provision of safety nets, when required.
- (9) Location of and access to equipment.
- (10) Location of amenities, such as plants, security cameras and flood lights at high locations.
- (11) First aid facilities and trained personnel.

For complete detailed Design Considerations for Management of Fall-Hazards during design phase, see Appendix “E”

14.3 FALL-HAZARD IDENTIFICATION: DON planners, designers and **system safety engineers** should identify any Fall-Hazards that will be encountered by an employee working at heights or using means of access to or egress from a building or facility. In order to assist in identifying Fall-Hazards, special considerations should be given to:

- a. Consultation, communication, and coordination with safety and health professionals.
- b. Knowledge of injuries arising from falls that have occurred at a workplace or at similar workplaces.
- c. Communication with various A/Es and contractors to find out if “at risk” workers are having or are likely to have problems while performing their jobs.
- d. Accidents or near-miss incidents related to falls at the workplace or similar workplaces; review safety web pages for various accidents that occurred at similar workplaces.
- e. Review of relevant fall-protection standards, instructions, regulations, and guidance documents.
- f. Communications with employees of similar facilities to determine what type of risks an employee would face during the performance of their duties.
- g. Conducting a walk through inspection of the facility or similar facilities to become familiar with various risk situations.
- h. Compiling statistical records indicating potentially unsafe work practices.

14.4 RISK ASSESSMENT: It is the responsibility of the planner or the designer to assess risk of injury to employees—while the employees are at the workplace during performance of their work— resulting from each hazard that involves falling.

a. Risk in relation to any injury or harm means the probability of that injury or harm occurring is increased. If a hazard is identified, the risks associated with such hazard can be assessed. Assessment of risks will help planners, designers, and system safety engineers determine the potential injury and thus help identify methods to reduce risks. The necessary steps in a risk assessment process may include the following:

- (1) Identify the specific hazardous/situation that might occur in a workplace.
- (2) Identify the nature of the decisions to be made about hazards and who is responsible for making these decisions.
- (3) Define and decide how such information needs to be presented to the decision makers.

b. The required information may include the determination and assessment of the following:

- (1) Size, height, and layout of a workplace.
- (2) Material handling methods or accessing all material or equipment at different locations of the facility.
- (3) Location and condition of all equipment and/or material used in a workplace.
- (4) The number, type of work, and movement of all employees in a workplace, planned facility, or building.

14.5 RISK CONTROL: Planners and designers should consider the means by which risk may be eliminated or reduced. Once risks have been assessed, measures should be taken to control the hazards of falling in accordance with the hierarchy or preferred order of control measures. These range from eliminating the worst hazards to the use of other methods that reduce risks. Specific control measures may include the following:

- a. Plans or designs of new or modifications to existing buildings, structures, or facilities should take fall prevention into consideration.
- b. Evaluate methods or the way jobs can be performed safely to eliminate or reduce the likelihood of a fall.
- c. Organize and schedule work so that employees do not interfere in safety measures taken or increase the risk of a fall for themselves or others
- d. Identify the information and knowledge required by contractors to enable them to work safely at heights.
- e. Collect, assemble, and present the information required to eliminate or reduce hazards.

August, 2013

- f. Identify the training or knowledge requirement to work safely if there is a risk of falling.

14.6 HIERARCHY OF CONTROL MEASURES

Elimination of Fall-Hazards is the preferred control measure. For other control measures See Chapter 7.

End of Section

15.0 GUIDANCE - FALL PROTECTION FOR AIRCRAFT MAINTENANCE AND INSPECTION WORK

15.1 INTRODUCTION

Falls from aircraft are potential sources of injuries and fatalities to aircraft maintenance personnel, aircrew, and inspectors. This document is designed to provide guidance to mitigate these risks and help to ensure the safety of all personnel who perform ashore aviation maintenance and inspection work at the organizational, intermediate, and depot levels.

15.2 APPLICABILITY

This guidance document applies to all Navy and Marine Corps Military and Civilian personnel worldwide involved in aircraft maintenance and inspection work on Navy and Marine Corps Facilities where personnel are exposed to the hazard of falling from heights and/or there is a need for fall protection. This document does not apply to shipboard operations.

15.3 PURPOSE

The purpose of this Chapter is to provide administrative tools, criteria, and safe practices to mitigate fall hazards when conducting aircraft maintenance and inspection work at heights. Commands performing aviation maintenance are required to perform operational risk management (ORM) to identify, assess, determine and implement controls to mitigate hazards during aircraft maintenance evolutions, inspections, and other related work. Establishment and management of a site specific fall protection program that utilizes safe work procedures, practices, and proper fall protection equipment, systems, and methodologies, including rescue procedures and proper training, will protect personnel exposed to fall hazards from heights while working on or inspecting aircraft. The Fall Protection Guide for Ashore Facilities contains information which can assist the Fall Protection Program Managers in developing their activity's program.

15.4 FALL PROTECTION SYSTEMS AND EQUIPMENT USED FOR AIRCRAFT MAINTENANCE AND INSPECTION WORK

Fall protection and fall protection methodologies are pieces of the overall hazard analysis and prevention plan for an aviation maintenance and/or inspection evolution. Location of the aircraft or potential fall exposure, nature of the task, environmental conditions, work area of the aircraft or working platform, and consideration for other potential hazards that may be introduced with the use of fall protection methodologies, shall be considered for each task. Consideration must be given to all hazards encountered with the execution of a particular maintenance or inspection task, to determine the best and safest course of action. For example, moving aircraft in order to make space for fall protection equipment, especially in confined and/or areas with high density of other aircraft and equipment, adds additional hazards that may outweigh those of the fall hazard.

Special consideration must be given to the use of fall protection equipment and systems on active flight lines due to the risk of foreign object damage (FOD) and the potential effects of rotor, jet, or propeller wash. If maintenance or inspection work is required on the flight line, consideration should be given to utilizing a designated maintenance area that is free from the additional hazards that may be caused by propeller, jet, or rotor wash. Where these hazards cannot be controlled effectively, then administrative controls may provide the best fall protection methods on active flight lines. In this case, personnel shall use deliberate ORM and other administrative controls to mitigate fall hazards.

If the Competent Person for Fall Protection determines that the use of fall protection equipment is not feasible or practicable based on the overall hazard analysis, personnel shall use deliberate ORM and other administrative controls to mitigate fall hazards in accordance with guidance of the Competent Person for Fall Protection. A primary objective of the Fall Protection and Prevention Plan, discussed in Section 15.7, item (4) of this Chapter, is to provide site specific, standard methods to mitigate fall hazards associated with routine tasks and to provide guidance, should deviation to standard methods be required.

The following paragraphs list types of fall protection systems that can be used for aircraft maintenance and inspection, in cases where fall hazards cannot be eliminated. They are listed in accordance with the hierarchy of controls, stated in Chapter 13 of OPNAVINST 5100.23 (series), and Chapter 7 of the Navy Fall Protection Guide for Ashore Facilities. For more details on fall protection equipment and systems, see Chapter 8 of this guide. Navy and Marine Corps activities must determine those fall protection measures which must be taken, based on risk analysis of the work or inspection to be performed.

(1) Movable and Stationary Work Platforms. Where work is performed from elevated work platforms four feet or higher, the work platforms shall be equipped with a standard guardrail and safe method of access, or other fall protection system that mitigates potential fall hazards. Mobile servicing platforms are authorized, but shall be required to provide additional fall protection equipment per the manufacturer's specifications. Work platforms shall comply with OPNAVINST 510.23 (series) and OSHA 29 CFR 1910.

(2) Personal-Fall-Arrest System. A system used to arrest a person during a fall from a working level. It consists of an anchorage system, connecting means, and full body harness and may include a lanyard, deceleration device, lifeline, or suitable combination of these. A personal fall arrest system shall be rigged so that employee arrested fall will not come in contact with a lower level or object. Safety belts (body belts) shall not be used. Suitable anchor points for personal fall arrest systems include horizontal lifeline systems, moveable and/or fixed anchorages attached to a rigid rail or beam, and vacuum type anchors. Vacuum anchors shall not be used on composite or thin shelled aircrafts. They shall only be used on thick shelled airframes. **Before using the vacuum system, approval by the cognizant technical authority over the subject airframe is required.**

(3) Restraint System. A system consisting of equipment and components connected together designed to restrain a person from reaching an exposed fall hazard.

August, 2013

(4) Administrative controls. These are controls that reduce risks through specific administrative actions. Methods for implementing administrative controls include:

- a) Fall Hazard Awareness Training for personnel performing elevated work.
- b) Providing suitable warnings, markings, placards, signs and notices.
- c) Establishing written policies, programs, instructions, and SOPs.
- d) Conducting a deliberate ORM with consideration of the following as a minimum.
 1. Maintenance or inspection work duration,
 2. Environmental factors such as wind, rain, snow, or ice,
 3. Probability of fall,
 4. Hazards of fall (obstacles, height, etc.)
 5. Slippery materials or substances on aircraft surfaces
 6. Actual requirement for work to be completed
- e) Limiting the exposure to a hazard (by reducing the number of personnel, and/or the length of time personnel are exposed).

15.5 APPLICABLE STANDARDS, REGULATIONS, SOPS, AND INSTRUCTIONS

Military aviation maintenance and inspection is inherently dynamic and fraught with potential hazards. OPNAV 5100.23 (series) requires fall protection when working 4 feet or more above lower levels to be mitigated by one or more of five hierarchies of control measures. In addition, federal OSHA fall protection regulations apply to civilian personnel at all times. Federal OSHA regulations also apply to military personnel conducting intermediate level and depot level maintenance at all times, and organizational level maintenance when conducting maintenance or inspections not directly involved in military flight operations. Federal OSHA regulations do not apply to military personnel involved in organizational level maintenance and preflight inspections directly involving military flight operations; however, OPNAV 5100.23 (series) requirements remain in force. In all cases, the use of fall protection shall be used to the maximum extent feasible, and the use of deliberate operational risk management is required for all aviation maintenance and/or inspection evolutions.

15.6 APPLICATION OF OPERATIONAL RISK MANAGEMENT

Risk Management (RM) is a decision making tool used by personnel at all levels, to increase effectiveness by identifying, assessing, and managing risks. RM reduces or offsets risks by systematically identifying hazards and assessing and controlling the associated risks, allowing decisions to be made that weigh risks against mission or task benefits. By reducing the potential for loss, the probability of a successful mission or task is increased. Operating safely by managing risk means accepting risk when benefits outweigh the cost, accepting no unnecessary risk, anticipating and managing risk by planning, and making risk decisions at the right level. Applying the RM process will reduce fall mishaps, and protect personnel exposed to fall hazards when performing aircraft maintenance and inspection work. Utilization of oral or written RM shall be required during any evolution where a fall hazard exists.

15.7 GUIDANCE TO MEET COMMANDER NAVAL AIR FORCES (CNAF) FALL PROTECTION PROGRAM ADMINISTRATIVE REQUIREMENTS

August, 2013

Commander Naval Air Forces Pacific and Atlantic issued coordinated naval message DTG 290027Z Sep 10, 2010 to issue program requirements and ensure program compliance as part of a Navy wide effort to achieve the DON Safety Vision for 2009 and Beyond and Secretary of Defense's (SECDEF) 2012 mishap reduction goals. The CNAF requirements for a fall protection program are taken directly from requirements put forth by Chapter 13 of OPNAVINST 5100.23 Series for a comprehensive fall protection program. This Section provides specific execution guidance for program compliance for CNAF Air Squadrons, and may be followed by NAVAIR and RESFOR Air Squadrons:

(1) Written Fall Protection Program - OPNAVINST 5100.23 Series, Chapter 13, and Chapter 3 of the Fall Protection Guide for Ashore Facilities, require all commands to develop a written Fall Protection program. This written program must be site specific and tailored to the individual command's equipment and requirements based on the hazard assessment. For example, if the unit does not utilize harness type fall protection equipment, the associated items such as rescue procedures may be omitted. Alternate type/model/series specific templates may have been developed for your particular aircraft. Contact your wing Safety Department to determine if a template for your type/model/series (T/M/S) has been generated. The command policy should contain two appendices. Appendix one should be the Fall Hazard Survey and appendix two should be the Fall Protection and Prevention Plan. Although the FP guide has a sample written FP program, paragraph 15.9 of this chapter includes a template more specific to aviation that the commands can tailor to their needs.

(2) Duties and Responsibilities- The command Fall Protection Program manager shall ensure that assigned personnel have the necessary skills, knowledge, training, and expertise to manage, administer, and implement the fall protection program. At a minimum, the command shall have a designated Fall Protection Program Manager, and End-Users of Fall Protection. Chapter 4 of the Fall Protection Guide for Ashore Facilities provides additional guidance for positions within the program, and duties and responsibilities. The following positions should be included in the command fall protection program with their required qualifications and responsibilities:

a) Aviation Squadron Fall Protection Program Manager (FPPM) - A person authorized and designated in writing by the command responsible for the development and implementation of the Fall Protection Program. The FPPM shall ensure that personnel exposed to fall hazards and other personnel involved in the program receive adequate training as outlined in appendix A of reference (a). Aviation FPPMs may contact their TYPE WING Safety Offices for information on possible FPPM training options. The Program Manager position need not be an exclusive title designation. With adequate education, training, and experience, the same person also may function as a qualified person or competent person.

b) Competent Person for Fall Protection- A person, designated in writing by the command and trained in accordance with Reference (a) requirements, who is capable of identifying hazardous or dangerous conditions in the personal fall-arrest system, or any component thereof, as well as in their application and use with related equipment, and has the authority to take prompt corrective measures to eliminate the hazards of falling., The alternative Program Manager course described in paragraph above, does not train

August, 2013

personnel to the Competent Person level, and shall not allow a graduate designation as equivalent to Competent Person for Fall Protection. To be trained to the Competent Person level, personnel must attend a Competent Person training course as approved by ECHELON II in accordance with OPNAVINST 5100.23 Series, Appendix 13-A. Regional safety offices maintain personnel trained to the Competent Person level and who are available to support aviation units by request.

c) Qualified Person for Fall Protection (optional) – A person with a recognized engineering degree or professional certificate, and with extensive knowledge, training, and experience in the field of fall protection; who is capable of performing design, analysis, and evaluation of fall protection systems and equipment. Qualified personnel from Naval Facilities Engineering Command (NAVFAC) personnel can fulfill this role as required.

d) End-User of Fall Protection – A person who has been trained in the use of assigned personal fall protection equipment, including hands-on training in a typical fall hazard situation. If the end-user will be climbing aircraft without harness-type protective systems, the end-user should also be trained and designated as a Qualified Person for Climbing Aircraft. End-user training is provided by someone who is trained and qualified, at a minimum, as a Competent Person for Fall Protection.

e) Qualified Person for Climbing Aircraft (as required) - A person who has been trained on the proper method to safely climb specific aircraft.

f) Competent Person for Inspection of Fall Protection Equipment (as required) - A person who has been trained by the Competent Person or Qualified Person for fall protection to perform and document inspections of personal fall protection equipment. Personnel trained as an Aviation Squadron Fall Protection Program Manager can also perform these inspections.

(3) Workplace Survey and Assessment of Fall Hazards

a) Workplace Survey – Paragraphs 15.9.2 and 15.10.1 provide a template and a checklist for conducting workplace surveys. Development of an effective fall protection program is similar to the ORM process, where the first step is hazard identification. A site and workplace specific Fall-Hazard Survey will help identify potential fall hazards at the workplace. A Competent Person for Fall Protection or an Aviation Squadron Fall Protection Program Manager shall conduct the workplace survey. The fall hazard survey shall be conducted annually for comparison purposes.

b) Hazard Assessment – Once hazards are identified in the workplace survey, the hazards must be assessed. OPNAVINST 3500.39 (series) ORM provides matrices to assess hazards based on mishap probability and severity. Considerations such as potential environmental conditions should be included in each hazard assessment.

c) Workplace Survey Report – Identification and assessment of fall hazards in addition to comprehension of the tasks to be performed by personnel working at heights which will allow the Competent Person for Fall Protection or Program Manager to develop

August, 2013

alternatives to mitigate fall hazards. Chapter 5, Section 5.3 of the Fall Protection Guide for Ashore Facilities provides guidance for preparing workplace survey reports. The Workplace Survey Report should list all fall hazards (height and hazards for each elevated working platform or area), provide a list of maintenance tasks that may be executed for each elevated working area, and provide a risk assessment for each task. Tasks may be grouped for assessment purposes for each elevated working area if they pose the same risk. Caution must be applied to grouping tasks that have different risk assessments. For example, applying torque to a main rotor head bolt may present a much greater hazard severity and probability than inspection of the main rotor head servicing despite both tasks being conducted on the same elevated working platform. A Workplace Survey Report is site specific, but reports for a particular T/M/S may have already been completed and can serve as a template for alternate sites. Contact your wing Safety Officer for potential templates.

(4) Aircraft Fall Hazard Prevention and Control – Each task identified in the workplace survey report must be mitigated with one of the five control methods listed in Chapter 13 of OPNAVINST 5100.23 Series according to the hierarchy or preferred order of control measures for fall hazards. Each maintenance task (or tasks as grouped in the workplace hazard assessment) to be executed and its corresponding control method(s) must be delineated as part of the site specific Fall Protection and Prevention Plan. This plan is to be included as enclosure two in the squadron fall protection program instruction. Chapter 7 of the Fall Protection Guide for Ashore Facilities, paragraphs 15.9.3 and 15.10.2 of this chapter provides general guidance, plan requirements, instructions for completing the plan, and a sample plan. Contact your wing Safety Officer to determine if a fall protection and prevention plan has already been developed for your airframe. Additional general guidance to be included in fall protection and prevention plans, as applicable, follows:

a) Maintenance and Inspection Work –

1. Personnel shall be trained to recognize the hazards of falling, fall risks at the worksite, recognition of fall-hazard deficiencies, and safe use of the equipment they are operating on including integrated features such as steps and hold points, and the selection and safe use of fall protection equipment.
2. Designated walkways shall be identified and used wherever possible. Walkways are pre-identified paths that a person is permitted or allowed to walk on without the use of fall protection equipment.
3. Personnel working on aircraft surfaces should wear slip-resistant soled shoes, cranials, and other appropriate PPE.
4. Good housekeeping practice is paramount, and shall be enforced or implemented. Clean all aircraft surfaces immediately when hydraulic fluids, oils, and other fluids contaminate the worksite.

August, 2013

5. Winds or other environmental variables such as rain, snow, frost, or ice that may preclude the safe performance of maintenance or inspection work shall be considered in the ORM executed for that evolution.
6. Where the use of fall protection equipment is not feasible (e.g., active flight line, preflight inspections); commands shall utilize ORM, at a minimum, to analyze and determine alternate methods (administrative controls) to mitigate risk.

b) Cleaning, Washing or deicing Aircraft

1. To protect against falls while cleaning, washing, or deicing aircraft, personnel should not be allowed to climb or walk on wet, frost-covered, or icy surfaces.
2. For washing or cleaning aircraft, separate elevated work platforms or work stands and long-handle brushes shall be used to the maximum extent possible. This does not preclude the additional use of other fall protection systems.
3. Where it is necessary to walk on aircraft wings or other surfaces during washing, extreme care shall be exercised and other control measures, as appropriate, shall be utilized, such as horizontal life-lines or self-retracting-lanyards (SRLs), to which a full body harness can be attached.

(5) Training of Fall Protection Program Managers and End-users – Training requirements for all personnel involved in the fall protection program, including personnel who may be exposed to fall hazards when performing aircraft maintenance or inspection work, are addressed in the OPNAVINST 5100.23 (series), Appendix 13-A. **In addition, ESAMS Course #4463 titled CNAL and CNAP Wing/Squadron Fall Protection Program Managers Training is also available. Contact your Administrative Chain of Command for possible training alternatives.**

(6) Inspection, Maintenance, Storage, and Care Procedures for Fall Protection Equipment – Chapter 11 of the Fall Protection Guide for Ashore Facilities provides guidance, checklists, and specific requirements for this topic. The fall protection program instruction must address specific inspection, maintenance, storage, and care procedures for the fall protection equipment possessed and/or utilized by the command. Manufacturers' instructions and recommendations may provide a good starting point for these requirements. Checklists, maintenance requirement cards, and pre-operational inspection cards should be developed for each piece of fall protection equipment by a competent person for fall protection or fall protection program manager and approved by the responsible authority.

(7) Rescue Procedures- Chapter 10 of the Fall Protection Guide for Ashore Facilities provides guidance and templates for this requirement. A site specific rescue plan shall be prepared in writing and maintained for all instances where personnel work at heights while utilizing harness-type fall protection systems. If the rescue will be performed by the Fire Department or other Governmental Jurisdictional Agency, a written Pre-Incident Plan is required. The rescue plan shall contain detailed procedures on the methods of rescue to include methods of self rescue, equipment used in the rescue procedure, training requirements including

August, 2013

specialized training for rescuers, procedures for requesting rescue, and a pre-mishap medical plan should medical assistance be required. The rescue plan should be included as part of the written Fall Protection and Prevention Plan.

(8) Audits and Evaluation- Chapter 3 of the Fall Protection Guide for Ashore Facilities provides compliance checklist for the Fall Protection Program which can be used for auditing the program. Program audits should be conducted semiannually, but shall be conducted annually as part of the command safety self-assessment described in OPNAVINST 5100.23 (series) and MCO 5100.29 series.

(9) Designation of a Fall Protection Program Manager (FPPM) to oversee the administrative requirements, equipment selection, and inspection aspects of the program- this responsibility should be assigned to the command Safety Officer, however this position may be assigned to a senior (E-7 or above) with appropriate training per the requirements stated above in Paragraph 15.7(5).

15.8 FUNDING AND PROCUREMENT OF FALL PROTECTION EQUIPMENT

Fall protection equipment required but not provided through support equipment (S/E) avenues should be procured by the squadron or type wing. If squadron or type wing funding is unavailable, funding may be available for fall protection methods and solutions through the Navy Hazard Abatement Program. The Hazard Abatement (HA) Program is a part of the Navy and Marine Corps Mishap Prevention and Hazard Abatement (MPHA) Program managed by NAVFAC. In order to apply for this funding, the FPPM must establish an account with the NAVFAC Single Sign-on (SSO) website <https://portal.navfac.navy.mil/private>). Once registration is complete and a login established, the FPPM must establish an account with the Hazard Abatement Database. The link to this database can be found under the "Safety message Boards" link under the "NAVFAC governance boards" Section on the left hand portion of the screen once signed in to the NAVFAC portal. Once in the safety message board Section, the Hazard Abatement link is displayed under "NAVFAC Safety" within the "Home" tab. Once within the Hazard Abatement Section, select "Hazard Abatement Database" and follow the steps to submit your request for Hazard Abatement funding.

The Navy and Marine Corps Hazard Abatement program evaluates all submitted hazard abatement funding requests from all hazard areas before determining what projects shall be selected for funding. The program has funded several aircraft fall protection projects and helped determine appropriate solutions; but each submitted Hazard Abatement project is evaluated on its merits before being selected for completion. Furthermore, this is no guarantee of selection for a submitted project. The project screening and selection process normally takes place annually, with projects selected for completion in the following fiscal year.

Several hazard assessments already have been executed for various T/M/S aircraft. Though hazard assessments are site specific, previously executed assessments provide insight into fall protection hazards and solutions and may be used to request funding. The point of contact for the Hazard Abatement Program can be reached at (619) 532-2025.

August, 2013

15.9: EXAMPLES OF FALL PROTECTION PROGRAM DOCUMENT TEMPLATES

The following are templates to assist Navy Aviation Commands establish, implement and manage viable fall protection programs. These templates include the following:

- (1) Written Fall Protection Program Template;
- (2) Fall Hazard Survey Report Template;
- (3) Fall Protection and Prevention Plan Template.

End of Section

August, 2013

15.9.1 Written Fall Protection Program (Template) (Specific to Aviation Commands)

COMMAND NAME INSTRUCTION XXXX.XX

From: Commanding Officer, **COMMAND NAME**

Subj: FALL PROTECTION PROGRAM

Ref: (a) OPNAVINST 5100.23(series); MCO 5100.29(series) or NAVMC DIR 5100.8
(b) Department of the Navy Fall Protection Guide for Ashore Facilities
(c) CNICINST 5100.3
(d) OPNAVINST 5102.1(series)
(e) OPNAVINST 3500.39 (series)

Encl: (1) Fall Hazard Survey Report
(2) Fall Protection and Prevention Plan

1. Purpose. The purpose of this instruction is to establish a command Fall Protection Program, provide policy and requirements for the implementation of the program, and establish procedures on fall protection and fall prevention for **COMMAND NAME** personnel working at heights and/or exposed to fall hazards while conducting aircraft maintenance and inspection work.

2. Applicability. This program applies to all **COMMAND NAME** military and federal civilian personnel who are exposed to fall hazards when performing maintenance or inspection work on an elevated, walking, or working surface with unprotected sides, edges, or openings, from which there is a possibility of falling four feet or more to a lower level; or where there is a possibility of a fall from any height onto dangerous equipment, into a hazardous environment, or onto an impalement hazard.

3. Cancellation. Instruction XXXX.XX

4. Background. Falls from heights are a major cause of injuries and fatalities in the work place. Reference (a) directs all Navy and Marine Corps activities to establish a managed fall protection program. The nature of aviation maintenance and inspection requires that **COMMAND NAME** personnel work at heights, thereby exposing them to fall hazards.

5. Command Fall Protection Policy. **COMMAND NAME** is committed to provide a safe working environment for its personnel exposed to fall hazards and eliminating preventable mishaps. Mission accomplishment is our number one task, but we cannot accomplish this task if we do not do our utmost to ensure the safety of our personnel. This program is part of an overall command safety program designed to enhance operational readiness by preventing injury or death of personnel through careful management of material resources.

August, 2013

a. **COMMAND NAME** personnel shall take every reasonable precaution to protect themselves and others while working at heights.

b. In accordance with reference (a), **COMMAND NAME** may use the Department of the Navy Fall Protection Guide for Ashore Facilities [reference (b)], as a guide when creating their own site specific program, plans, and policies.

6. Duties and Responsibilities. **COMMAND NAME** leadership shall ensure that all personnel assigned to the fall protection program have the necessary skills, knowledge, training, and expertise to manage, administer, and implement the fall protection program.

a. Command Safety Officer: Shall provide oversight of the command Fall Protection Program.

b. The Command Fall Protection Program Manager shall:

(1) Develop and implement the command fall protection program.

(2) Manage and coordinate the command's core Fall Protection program.

(3) Perform and document reviews, and evaluations of operations, facilities, materials, and equipment.

(4) Conduct fall hazard survey and prepare survey report.

(5) Coordinate workplace and fall-arrest system inspections with the supporting Competent Person for Fall Protection.

(a) The Competent Person support services can be requested from the supporting Regional/local installation safety office.

(b) The Competent Person services may be provided by command personnel if they have completed the required training course as described in Appendix 13-A of reference (a).

(6) Correct or abate identified fall hazards.

(7) Obtain consulting services from the supporting Regional/local installation safety office on technical aspects of the program.

(8) Coordinate with the supporting Regional/local installation safety office to analyze core effectiveness through the annual safety self-assessment process.

(9) Coordinate core fall protection training for all personnel who are exposed to fall hazards and End-users of fall-arrest systems, when applicable.

August, 2013

(10) Coordinate with the supporting Regional/local installation safety office any other support described in Table 1 of reference (c) required to ensure the proper management of this program.

7. Fall-hazard Prevention and Control. Reference (a) requires each Navy activity to survey the workplace to identify potential fall hazards and prepare a “Fall Hazard Survey Report”. Reference (a) requires a “Fall Protection and Prevention Plan”, prepared by a Competent Person for Fall Protection, or by a Qualified Person for Fall Protection, as part of a managed fall protection program. The trained FPPM may also prepare the fall protection and prevention plan

a. The Fall Protection and Prevention Plan shall provide site specific guidance for tasks executed at **COMMAND NAME**.

b. Prior to visiting a site at another Navy Activity, **COMMAND NAME** employees who will be climbing or ascending equipment different from the equipment addressed in the **COMMAND NAME** Fall Hazard Survey Report should review that the host Activity’s “Fall Hazard Survey”.

8. Fall Protection Training. **COMMAND NAME** personnel who have the potential for exposure to fall hazards and/or those involved in the Fall Protection Program shall be trained in fall prevention and fall protection in accordance with the requirements in reference (a), and the training requirements in reference (b). A Competent Person or a vendor who has the knowledge, expertise, and education to deliver the training shall train end-users.

a. Initial Training. Command personnel exposed to fall hazards shall complete the following training:

(1) Fall hazard awareness training: general fall hazard awareness training shall be provided by either a Competent Person for Fall Protection or by completion of a Navy-approved general fall hazard awareness training, such as the Enterprise Safety Applications Management Systems (ESAMS) course #1259.

(2) Personnel required to climb aircraft shall be qualified climbers.

(a) Qualified climbers shall be trained and knowledgeable regarding those surfaces which are, and are not, able to support a climber; and shall observe airframe restrictions. Training shall include:

- Requirement for cranial protection
- Areas on airframe authorized for use as a step
- Checking to ensure that steps are cleaned of slippery substances
- Instruction to maintain three points of control on aircraft at all times

(b) Qualified climbers shall rely on experience, proper training, and the use of time-critical ORM as described in reference (e) to minimize the risk of a fall.

August, 2013

(3) End-users of Fall-Protection shall also undergo “Hands-On” training on the specific personal fall-protection system and equipment used at the command. This training must be performed by a Competent Person for Fall Protection. End-user training shall include training on:

- Safe use of equipment
- Proper application of equipment
- Equipment limits
- Estimation of fall distances
- Methods of inspection, storage, care, and maintenance
- Applicable regulations
- Recognition of fall-hazard deficiencies
- Site specific procedures.

b. Retraining. Retraining in relevant topics shall be provided to the end-user and/or qualified climbers when:

- (1) Personnel have been observed using maintenance stands or fall protection equipment in an unsafe manner.
- (2) Personnel have been involved in a mishap or a near-miss incident.
- (3) Personnel have received an evaluation that reveals that he or she is not using the fall protection equipment properly.
- (4) An End-user is assigned a different type of fall protection equipment.
- (5) A condition in the workplace changes in a manner that could affect the safe use of the fall protection equipment that the end-user is to utilize.

c. Refresher training. Personnel exposed to fall hazards shall receive periodic awareness and hands-on equipment (when applicable) refresher training as required by reference (a).

9. Inspection, Storage, Care, and Maintenance of Fall Protection Equipment. Command fall protection equipment shall comply with the requirements of reference (a); applicable requirements in reference (b); and the manufacturer’s requirements for the inspection, storage, care and maintenance of fall protection equipment.

a. A Competent Person for Fall Protection or a Competent Person for Equipment Inspection shall perform a documented inspection on each piece of fall protection equipment annually using criteria found in reference (b) or appropriate Maintenance Required Card (MRC).

b. End-users of Fall Protection shall inspect fall protection equipment prior to each use using criteria in reference (b) or appropriate MRC.

10. Mishap Reporting.

August, 2013

a. Any fall-from-height experienced by command personnel shall be reported to the FPPM or Safety Officer.

b. If a fall results in fall-arrest equipment activation the event shall be reported as a near-miss using the Hazard Report in reference (c).

11. Program Audits and Evaluation. The FPPM shall audit the program annually (at a minimum) per Chapter 3 of reference (a).

12. Rescue Plan. When fall-arrest systems are utilized the FPPM shall coordinate with the supporting Competent Person for Fall Protection to create a rescue plan which meets the requirements in reference (b). The rescue plan shall then be incorporated into the command Fall Protection Program.

(Signed) C. O. COMMAND

15.9.2 MH-60 FALL HAZARD SURVEY REPORT (Template)

1. Purpose. The purpose of this survey report is to provide a baseline assessment of fall protection and associated hazards on the MH-60S aircraft, and points for consideration when executing tasks required for aircraft maintenance and inspection. This analysis designates three distinct locations for aircraft maintenance, three distinct working areas on the aircraft itself, and designates tasks to be performed in these areas as high risk or low risk.

a. Any fall, even a fall on the same level, can result in disability or death; but for the purpose of this analysis, fall severity shall be generalized, based on potential fall distance.

(1) Falls of four feet or less are considered relatively minor.

(2) Falls from 4-10 feet are considered moderate falls that likely would result in bone fractures, severe contusions, and a lost-time injury.

(3) Falls of greater than 10 feet are considered severe and may result in severe injury including partial disability or death.

(4) Falls from any height where there is potential of falling onto hazardous conditions (e.g. machinery) are considered severe.

2. Mitigation Method. Fall protection and fall protection methods are parts of the overall hazard analysis and prevention plan for an aviation maintenance and/or inspection evolution. Location of the aircraft or potential fall exposure, nature of the task, work area of the aircraft or working platform, and consideration for other hazard potentials that may be introduced with the use of fall protection methods, shall be considered for each task.

a. For example, moving aircraft in order to make space for fall protection equipment, especially in confined and/or areas with high density of other aircraft and equipment, may create additional hazards that outweigh those of the fall hazard.

(1) The use of fall protection systems and equipment on an active flight line may introduce foreign object damage (FOD) hazards and hazards associated with jet, propeller, and rotor wash.

(2) Consideration must be given to all hazards involved with the execution of a particular maintenance or inspection task to determine the best and safest course of action to protect personnel as well as equipment.

3. Hazard Analysis. Exposures to fall hazards are considered as the product of frequency of exposure, proximity to fall hazard, duration of exposure, security of area, and the environmental impact. These factors provide the overall probability of the fall.

August, 2013

a. Though the hazard assessments provided in this document are displayed using the tables in reference (d) which quantify fall hazards based on severity and probability of a hazard becoming a mishap

b. Where multiple fall hazards exist during a particular work task, the one with the highest associated risk (worst-case) shall be utilized to determine the proper fall hazard controls to use during the entire work task. A hazard assessment has been included for aircraft moves as a point for consideration in the overall hazard analysis of an aircraft maintenance or inspection.

c. This assessment is not all-inclusive of all hazards or conditions that may arise, but is a guideline for supervisors and workers to execute operational risk management, to protect personnel and materiel.

4. Fall Hazard Areas:

a. Tasks and ORM hazard assessments

(1) Tail Pylon

(a) Fall Hazard: Height of Total Exposure is approximately 12' from the top of tail gearbox cowling to the ground. The top step is approximately 10' depending on aircraft weight and servicing of the tail strut.

(b) High-Risk Tasks include:

1. Removal, installation, and/or maintenance on the tail gear box input seal and input flange.
2. Removal, installation, and/or maintenance on the tail rotor paddles.
3. Removal, installation, and/or maintenance on inboard and outboard retention plates.
4. Removal, installation, and/or maintenance of #6 driveshaft.
5. Removal, installation, and/or maintenance on tail rotor quadrant.

(c) Low-Risk Tasks include:

1. Preflight inspections to include daily and turnaround maintenance preflight inspections.
2. Servicing of tail rotor gearbox.
3. Resetting cam-locks on tail cowlings.

August, 2013

- (d) Risk: Steps integrated into airframe provide access to tail and associated components. Steps may be inadequate to maintain balance and mitigate risk of falling while attempting to perform aircraft maintenance and inspection. The risk of falling increases significantly with less than three points of contact between the aircraft and the person performing aircraft maintenance or inspection.
- (e) Hazard assessment:

HIGH-RISK TASK RAC MATRIX

	Probability			
Hazard Severity	A	B	C	D
I	1	1	2	3
II	1	2	3	4
III	2	3	4	5
IV	3	4	5	5

LOW-RISK TASK RAC MATRIX

	Probability			
Hazard Severity	A	B	C	D
I	1	1	2	3
II	1	2	3	4
III	2	3	4	5
IV	3	4	5	5

- (f) Mitigations:

1. Fall protection stand with appropriate PPE.
2. Use of integrated aircraft steps with appropriate PPE.
3. Deliberate ORM/Administrative controls. Some examples can include:
 - Consider specific part of aircraft used to climb onto aircraft and determine whether or not a safer alternate exists.
 - Check weather conditions and postpone aircraft climb if necessary.
 - Ensure aircraft surfaces are free of slippery substances.
 - Assure that boot soles are in good condition
 - Assure the climbing personnel maintain a minimum of three points of contact at all times.
 - Don cranial protection

August, 2013

(2) Hydraulics Bay Area

(a) Fall Hazard: Height of Total Exposure is approximately seven feet from the top of the decking of the hydraulics bay to the ground. This height is dependent on aircraft weight and the servicing of the struts.

(b) High-Risk Tasks to be performed:

1. Torque verifications or adjustments on main rotor damper mount bolts.
2. Torque verifications or adjustments on bifilar assembly and weights.
3. Torque verifications or adjustments on the Main Gear Box mount feet.
4. Torque verifications or adjustments of the main rotor blades.
5. Removal and/or installation of forward bridge.
6. Removal and/or installation of main rotor blades.
7. Removal, installation, and/or maintenance on primary servos.

(c) Low-Risk Tasks include:

1. Preflight inspections, to include Daily and Turnaround maintenance preflight inspections.
2. Servicing of hydraulic reservoirs.

(d) Risk: Steps integrated into airframes provide access to the hydraulics bay, transmission, main rotor, and associated components. Steps and working surfaces may be inadequate to maintain balance and mitigate risk of falling while attempting to perform aircraft maintenance and inspection in these areas. The risk of falling increases significantly with less than three points of contact between the aircraft and the person performing aircraft maintenance or inspection.

(e) Hazard assessment:

HIGH-RISK TASK RAC MATRIX

	Probability			
Hazard Severity	A	B	C	D
I	1	1	2	3
II	1	2	3	4
III	2	3	4	5
IV	3	4	5	5

August, 2013

LOW-RISK TASK RAC MATRIX

Hazard Severity	Probability			
	A	B	C	D
I	1	1	2	3
II	1	2	3	4
III	2	3	4	5
IV	3	4	5	5

(f) Mitigations:

1. Fall protection stand with appropriate PPE.
2. Use of integrated aircraft steps with appropriate PPE.
3. Deliberate ORM/Administrative controls. Some examples can include:
 - Consider specific part of aircraft used to climb onto aircraft and determine whether or not a safer alternate exists.
 - Check weather conditions and during inclement weather postpone aircraft climb if necessary.
 - Ensure aircraft surfaces are free of slippery substances.
 - Assure boot soles are in good condition
 - Assure that climbing personnel maintain minimum three points of contact at all times.
 - Don cranial protection.

(3) Area above Cabin

(a) Fall Hazard: The height of area above the cabin is approximately nine feet from the top of the decking above the oil cooler compartment to the ground. This height is dependent on aircraft weight and the servicing of the struts.

(b) High-Risk Tasks to be performed:

1. Removal and/or installation of the Rescue hoist.
2. Torque verifications or adjustments on main rotor damper mount bolts.
3. Torque verifications or adjustments on bifilar assembly and weights.
4. Torque verifications or adjustments on the Main gear box mount feet.
5. Torque verifications or adjustments of the main rotor blades.

August, 2013

- 6. Removal and/or installation of aft bridge.
- 7. Removal and/or installation of main rotor blades.
- 8. Removal and/or installation of the APU.
- 9. Removal, installation, and/or maintenance on primary servos.

(c) Low-Risk Tasks to be performed:

- 1. Preflight inspections to include Daily and Turnaround maintenance preflight inspections.
- 2. Servicing of utility hydraulic pump.
- 3. Servicing of the APU.

(d) Risk: Steps integrated into airframe provide access to an area above the cabin to include the oil cooler compartment, main engines, main rotor, ECS compartment, fire bottle compartment, APU compartment, and associated components. Steps may be inadequate to maintain balance and mitigate risk of falling while attempting to perform aircraft maintenance and inspection. The risk of falling increases significantly with less than three points of contact between the aircraft and the person performing aircraft maintenance or inspection.

(e) Hazard assessment:

HIGH-RISK TASK RAC MATRIX

Hazard Severity	Probability			
	A	B	C	D
I	1	1	2	3
II	1	2	3	4
III	2	3	4	5
IV	3	4	5	5

LOW-RISK TASK RAC MATRIX

Hazard Severity	Probability			
	A	B	C	D
I	1	1	2	3
II	1	2	3	4
III	2	3	4	5
IV	3	4	5	5

(f) Mitigations:

1. Fall protection work stand with appropriate PPE.
2. Use of integrated aircraft steps with appropriate PPE.
3. Deliberate ORM/Administrative controls. Some examples can include:
 - Consider the specific part of aircraft used to climb onto the aircraft, and determine if a safer alternate exists.
 - Check weather conditions, and during inclement weather postpone aircraft climb if necessary.
 - Ensure that aircraft surfaces are free of slippery substances.
 - Assure that boot soles are in good condition.
 - Assure that the person maintains a minimum of three points of contact at all times.
 - Don cranial protection.

b. Additional Hazard analysis for consideration:

(1) Aircraft move

(a) Hazard: Aircraft Move - MH-60S aircraft weigh between 15,000 and 22,500 pounds. Moving aircraft can be accomplished with tow tractors or manually. Aircraft moves can be highly dynamic evolutions that put personnel at risk of being fatally run over or injured. Aircraft moves also have high incidences of causing aircraft damage which can be quite costly and adversely affect mission readiness.

1. Where aircraft are parked in close quarters, the hazards associated are increased. Close quarters also make the aircraft movement much more technically demanding for personnel steering the aircraft being moved.

2. Chock walker personnel may be unable to remain safely out of the path of the aircraft.

(b) Hazard assessment:

Hazard Severity	Probability			
	A	B	C	D
I	1	1	2	3
II	1	2	3	4
III	2	3	4	5
IV	3	4	5	5

August, 2013

(c) Mitigations:

1. Use of appropriate, properly trained personnel.
2. Use of deliberate ORM prior to moving aircraft.

(2) Movement of fall protection equipment.

(a) Hazard: MH-60S aircraft have a main rotor diameter of over 53'8" feet with blades that can droop to less than four feet under certain circumstances. Movement of fall protection stands could result in aircraft damage.

(b) Hazard assessment:

Hazard Severity	Probability			
	A	B	C	D
I	1	1	2	3
II	1	2	3	4
III	2	3	4	5
IV	3	4	5	5

(c) Mitigations:

1. Use of appropriate, properly trained personnel to include spotters to mitigate contact between fall protection stands and rotor blades.
2. Use of deliberate ORM prior to moving equipment.

The elements contained in this Fall Hazard Survey Report have been reviewed and approved.

Lt J. B. Fallon (sign) _____
 (Squadron) Fall Protection Program Manager Date

Mr. No U. Knott (sign) _____
 Competent Person for Fall Protection

15.9.3 FALL PREVENTION AND PROTECTION PLAN

1. Description of fall hazards that may be encountered at the workplace by end-users during performance of their work. The MH-60S has three primary work areas that may expose personnel to fall hazards, as the working surfaces are greater than four feet above ground level. The working area forward of the main rotor mast shall be generalized and referred to as the hydraulics bay area. This area potentially exposes personnel to a fall hazard of seven feet. The working area aft of the main rotor head to the end of the fire bottle compartment shall be generalized as the oil cooler area and potentially exposes personnel to a nine foot fall hazard. Though the tail rotor area is not a work platform per OSHA definition, work may be executed on the integrated steps, exposing personnel to a potential 10 foot fall hazard as measured from the top step.

2. Type of fall protection/fall prevention methods or systems used for every phase of work. Military aviation maintenance and inspection is inherently dynamic and fraught with potential hazards. Reference (a) requires fall protection when working four feet or more above lower levels to be mitigated by one or more of five control measures. Additionally, Federal regulation mandates this requirement, except where employers can demonstrate that such fall protection systems are infeasible or would create a greater hazard.

a. Fall protection control measures are parts of the overall hazard analysis and fall protection and prevention plan for aviation maintenance and/or inspection. Location of the aircraft or potential fall exposure, nature of the task, work area of the aircraft or working platform, and consideration for other hazard potentials that may be introduced with the use of fall protection control measures, shall be considered for each task.

- (1) For example, moving aircraft in order to make space for fall protection equipment to execute a low risk task, especially in confined and/or areas with high density of other aircraft and equipment, adds additional hazards that may outweigh those of the unprotected fall hazard.
- (2) Consideration must be given to all hazards involved with the execution of a particular maintenance or inspection task to determine the best and safest course of action.
- (3) Fall Hazards shall be mitigated according to the hierarchy of controls as identified in reference (a).

b. The overall approach to fall prevention at **COMMAND NAME** shall be in the forms of prevention, engineering controls, and administrative procedures. As there are no anchor points or sufficient height above ground for proper employment of a fall-arrest system on the MH-60S airframe without the use of external equipment or an engineering change to the hangar, the use of fall-arrest system is not practicable at this time for **COMMAND NAME**.

(1) Feasibility of a fall-arrest system for applications within the hangar shall be explored in the future at **COMMAND NAME**.

August, 2013

(2) **COMMAND NAME** has fall protection stands that provide both fall prevention, on the backside of stands with handrails, and engineering controls, on the aircraft side of the stands, to minimize the potential for falls. The squadron also has B-1 and B-4 work stands, phase stands, and ladders that provide some degree of fall prevention and engineering controls.

(3) There are some locations where the use of stands is not practicable, due to overall hazard analysis, or mission requirements. In these situations or areas, administrative controls shall be utilized. The primary administrative controls utilized at **COMMAND NAME** are the use of qualified climbers, and deliberate and time critical ORM. Three primary aircraft locations shall be addressed in this plan: flight line, hangar bay, and wash rack.

c. Flight line: Fall protection equipment and systems generally are not authorized on active flight lines, due to the risk of foreign object damage (FOD), and the potential effects of rotor, jet, or propeller wash. Use of fall protection equipment in this environment may cause potential for greater hazards than the fall hazard itself.

(1) Fall protection equipment normally should not be utilized on an active flight line at **COMMAND NAME** unless an ORM assessment indicates that the presence of the equipment does not create a larger overall hazard to personnel than the risk of a fall.

(a) Maintenance should be performed in a hangar whenever feasible.

(2) Aircraft inspection and maintenance on active flight lines shall require the use of deliberate and time critical Operational Risk Management (ORM) and restricting access to qualified climbers in order to minimize the risk of a fall.

(a) In the consideration of using maintenance stands and/or Fall-arrest Systems where fall potential might be increased by moving aircraft into a hangar, ORM also should be applied.

(b) Consideration should be given to moving aircraft requiring high risk maintenance actions into the hangar in order to utilize maintenance stands and/or fall-arrest systems to prevent a fall.

d. Wash rack: Maintenance stands with guards or arrest systems shall be used for all aircraft washing procedures where maintenance personnel are on the aircraft greater than four feet above ground level.

(1) Other maintenance and inspection tasks executed at the wash rack not associated with aircraft washing shall be executed using the same fall protection measures as normally would be used in the hangar.

August, 2013

e. Hangar Bay:

(1) Tail. Due to the nature of the tail steps and increased potential for falls from greater heights, fall protection maintenance stands (with guardrails at the entire periphery) shall be used to the maximum extent practicable on all maintenance actions to the tail where the potential for a fall of four feet or more exists. B-1, B-4, phase, and/or fall protection stands shall be configured and positioned properly to mitigate the fall hazard.

(a) Should the use of a stand be deemed impracticable; a Competent Person for Fall Protection, as defined by OPNAVINST 5100.23 Series, Chapter 13, and Maintenance Control shall approve deviations and determine alternative fall protection methods, case-by-case. Nonetheless, railed maintenance stands, arrest systems, or other fall protection measures should be used, except in rare exceptions.

(b) Ladders also may be used for tasks determined low-risk by the fall hazard assessment, as long as they are used and set up properly. Personnel utilizing the ladder shall maintain three points of contact with the ladder at all times, and the ladder itself shall be positioned with four points of contact at all times.

(2) Hydraulics bay area. The hydraulics bay area has a maximum fall exposure of seven feet. Risk assessment for the specific task to be executed can be found in the hazard assessment (see Fall Hazard Survey).

(a) Fall protection stands shall be used to the maximum extent practicable on all maintenance actions in the hydraulics bay area, where the potential for falling four feet or greater exists.

(b) Where B-1, B-4, phase, and/or fall protection stands are used, they shall be configured and positioned properly to mitigate the fall hazard, and to prevent the creation of additional fall hazards which may be caused by improperly configured stands.

(c) Should the use of a stand be deemed impracticable for a high-risk task as defined in the hazard assessment (enclosure (1)); a Competent Person for Fall Protection and a Maintenance Control representative shall approve deviations; and they shall determine alternative fall protection methods, case-by-case.

(d) Should the use of a stand be deemed infeasible for a low-risk task as defined in the hazard assessment (Fall Hazard Survey); the end-user, under the direction of a Competent Person for Fall Protection, may utilize administrative controls, which shall include deliberate ORM prior to execution of the task.

1. The use of administrative controls as the sole fall protection methodology is authorized only during the rare occasions when the movement of, setup, and use of a fall protection stand or arrest system creates a greater hazard than the hazards associated with the low-risk maintenance action to be performed. For example, the hazard of moving maintenance or fall-arrest system stands onto an active flight line may outweigh a low risk fall hazard.

2. Normally, engineering controls (maintenance stands) or other controls to prevent a fall from occurring (fall-arrest system) always should be used.

(3) Oil cooler area. The oil cooler area has a maximum fall exposure of nine feet. Risk assessment for the specific task to be executed can be found in the hazard assessment (Fall Hazard Survey).

(a) Fall protection stands shall be used to the maximum extent practicable on all maintenance actions in the oil cooler area, where the potential for falling from a height of four feet or greater exists.

(b) If B-1, B-4, phase, and/or fall protection stands are used, they shall be configured and positioned properly to mitigate the fall hazard and prevent the creation of additional fall hazards which may be caused by improperly configured stands.

(c) Should the use of a stand be deemed impracticable for a high-risk task as defined in the hazard assessment (enclosure (1)); a Competent Person for Fall Protection, and a Maintenance Control member, must approve deviations and determine alternative fall protection methods, case-by-case.

(d) Should the use of a stand be deemed infeasible for a low-risk task as defined in the hazard assessment (Fall Hazard Survey) the end-user, under the direction of a Competent Person for Fall Protection, may utilize administrative controls which shall include deliberate ORM at a minimum, and execute the task.

1. The use of administrative controls as the sole fall protection method is authorized only during the rare occasions when the movement of, setup, and use of a fall protection stand or arrest system creates a greater hazard than the hazards associated with the low-risk maintenance action to be performed. For example, the hazard of moving maintenance- or fall-arrest system stands onto an active flight line may outweigh a low risk fall hazard.

2. Normally, engineering controls (maintenance stands) or a fall-arrest system should be used.

3. Training requirements for personnel exposed to fall hazards.

COMMAND NAME civilians and military personnel who use fall protection equipment (stands); and other Navy personnel involved in the fall protection program; shall be trained in accordance with reference (a), in order to recognize, evaluate, and control fall hazards.

a. Initial Training. Command personnel exposed to fall hazards shall complete the following training:

(1) Fall hazard awareness training: general fall hazard awareness training shall be provided by either a Competent Person for Fall Protection or by completion of a Navy-

August, 2013

approved general fall hazard awareness training, such as the Enterprise Safety Applications Management Systems (ESAMS) course #1259.

(2) Personnel required to climb aircraft shall be qualified climbers.

(a) Qualified climbers shall be trained and knowledgeable regarding what surfaces are and are not able to support a climber and shall observe airframe restrictions. Training shall include:

- Requirement for cranial protection
- Identification of areas on airframe authorized for use as a step
- Checking to ensure that steps are cleaned of slippery substances
- Methods to maintain three points of contact on aircraft at all times

(b) Qualified climbers shall rely on experience, proper training, and the use of time-critical ORM as described in reference (e), to minimize their risks of a fall.

(3) End-users of Fall-arrest Systems also shall undergo “Hands-On” training on the specific fall-arrest system equipment used at the command. This training must be performed by a Competent Person for Fall Protection. End-user training shall include training on:

- Safe use of equipment
- Proper application of equipment
- Equipment limits
- Estimation of fall distances
- Methods of inspection, storage, care, and maintenance
- Applicable regulations
- Recognition of fall-hazard deficiencies
- Site specific procedures

b. Retraining. Retraining in relevant topics shall be provided to the end-user and/or qualified climbers where:

(1) The end-user or qualified climber has been observed using fall protection equipment in an unsafe manner.

(2) The end-user or qualified climber has been involved in a mishap or a near-miss incident.

(3) The end-user or qualified climber has received an evaluation that reveals that he or she is not using the fall protection equipment properly.

(4) The end-user or qualified climber is assigned a different type of fall protection equipment.

(5) A condition in the workplace changes in a manner that could affect the safe use of the fall protection equipment that the end-user is to utilize.

August, 2013

c. Refresher training. Personnel exposed to fall hazards shall receive refresher training on the safe use of fall protection equipment at a minimum of every two years.

4. Type of fall protection equipment and systems provided to the employees that might be exposed to fall hazards.

a. Fall Protection Stands:

- (1) Aircraft Maintenance Platform Type B-1
- (2) Aircraft Maintenance Platform Type B-4
- (3) West Coast Weld Tech H-60 Helicopter Maintenance Platform
- (4) Metallic Ladder Mobile Work Platform SCS 8460 and SCS 9636-44

b. Ladders: Ladders are not technically fall protection equipment though they may be used to ascend working or inspection areas at heights when the use of fall protection equipment is not feasible or not available.

5. Fall-arrest Systems

a. When used as part of the fall protection program, fall-arrests systems (harnesses, lanyards, and associated hardware) shall be inspected per the Navy Fall Protection Guide for Ashore Facilities or appropriate Maintenance Required Card (MRC).

b. Fall-arrest systems shall be inspected annually by a Competent Person for Fall Protection.

(1) Inspection documentation shall be maintained by the Fall Protection Program Manager for a period of at least 5 years.

6. Current Competent Persons

a. Competent Person for Fall Protection: As designated by the CO and trained in accordance with Chapter 13 of OPNAVINST 5100.23 Series.

b. Competent Person for Equipment Inspection: As designated by the CO.

7. Fall protection equipment and instructions for assembly, disassembly, storage, maintenance, and care. B-1 and B-4 maintenance railed platforms are considered support equipment and shall be assembled, disassembled, and maintained by the support equipment division at Fleet Readiness Center.

a. Pre-operational inspections shall be conducted prior to each use by the end-user in accordance with the applicable NAVAIR technical manual.

August, 2013

(1) Phase and other maintenance stands not under the purview of the support equipment division shall be assembled, disassembled, and maintained per manufacturer instructions at a maximum one year interval by a Competent Person for Fall Protection or a Competent Person for Equipment Inspection.

(2) Maintenance stands shall be inspected by the end-user using the **COMMAND NAME** (local) pre-operational checklist. Fall protection maintenance stands shall be stored in accordance with manufacturers' instructions.

b. Ladders: "Little Giant" (or equivalent) ladders shall be inspected by the end-user prior to each use, and inspected at maximum one year intervals by a Competent Person for Fall Protection or a Competent Person for Equipment Inspection.

7. Rescue plan and procedures. **COMMAND NAME does not currently employ the use of fall-arrest systems or equipment. Should this type of equipment be utilized in the future by **COMMAND NAME** personnel, the FPPM shall coordinate Competent Person for Fall Protection support to create a rescue plan which meets the requirements in referenced (b). The rescue plan shall then be incorporated into the command Fall Protection Program.**

The elements contained in this Fall Prevention and Protection Plan have been reviewed and approved.

LT J. B. Fallon (sign) _____ Date _____
(Squadron) Fall Protection Program Manager

Mr. No U. Kuott (sign) _____ Date _____
Competent Person for Fall Protection

August, 2013

15.10 FALL PROTECTION FORMS/CHECKLISTS

The following are Site Specific Checklists to assist Aviation Commands develop fall protection program documentation. The checklists include:

- 15.10.1 Fall Hazard Survey Report;**
- 15.10.2 Fall Protection and prevention plan;**
- 15.10.3 Rescue Plan.**

The fall hazard forms above have been loaded to Naval Forms On-Line.

SECNAV 5100/2T Site-Specific Fall Hazard Survey:

https://navalforms.documentservices.dla.mil/formsDir/_SECNAV_5100_2T_11021.pdf

SECNAV 5100/3T Fall Protection and Prevention Plan:

https://navalforms.documentservices.dla.mil/formsDir/_OPNAV_5100_3T_11022.pdf

SECNAV 5100/4T Site-Specific Fall Arrest Rescue Plan:

https://navalforms.documentservices.dla.mil/formsDir/_SECNAV_5100_4T_11023.pdf

(Continued on next page)

August, 2013

15.10.1 Sample Site-Specific Aviation Maintenance Fall Hazard Survey Report (Form)

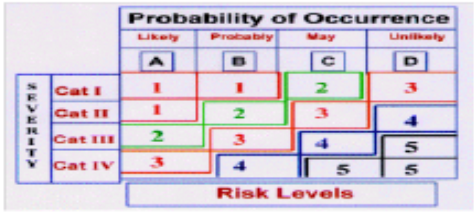
SITE-SPECIFIC FALL HAZARD SURVEY						E-Mail																															
GENERAL INFORMATION																																					
1. Activity/Command Name:					2. Date:																																
3. Hangar/Facility Number:			4. Work Area:																																		
4. Survey Conducted By (Name, title, code):		5. Date Conducted:	6. Approval By (Name, title, code):		7. Date Approved:																																
8. Fall Hazard Number (ex., 1, 2, etc.)		9. FP Program Manager (Name, Code):																																			
SURVEY INFORMATION																																					
10. Major Fall Hazard Type:				11. Work Location:																																	
12. Personnel Interviewed				Add Personnel Interviewed		Remove Personnel Interviewed																															
13. Guiding Regulation		14. Work Type:		15. Suggested Anchorages(s) (if fall arrest system used):																																	
16. Distance to Deck (ft):	17. Number of Personnel Exposed to Fall Hazard:	18. Frequency/Duration of Fall Exposure:	19. Exposure Risk:	20. Potential Severity of Fall:	21. Obstructions in Fall Path:																																
22. How is Fall Area Accessed:		23. Condition of Floor/Other Surfaces:	24. Historical Fall Mishaps at the Facility:	25. Lock Out/Tag Out Hazard:																																	
26. Is There a Risk of the Following (Check all that apply):			27. Recommended Fall Protection Solutions (Check all that apply):																																		
<input type="checkbox"/> Hot Objects <input type="checkbox"/> Chemical Hazards <input type="checkbox"/> Abrasive Surfaces <input type="checkbox"/> Sparks <input type="checkbox"/> Electrical Hazards <input type="checkbox"/> Moving Equipment <input type="checkbox"/> Flames <input type="checkbox"/> Sharp Objects <input type="checkbox"/> Active Flight Line			27a. Fall Arrest (FA) System: F <input type="checkbox"/> Horizontal Life-Line A <input type="checkbox"/> Portable System T <input type="checkbox"/> Overhead Beam Strap Y <input type="checkbox"/> Self-Retracting Lanyard E <input type="checkbox"/> Energy Absorbing Lanyard																																		
28. Anchorage(s) Locations (if applicable):			27b. Maintenance Stand w/rails:: Type <input type="checkbox"/> B-Stand <input type="checkbox"/> Commercial Stand <input type="checkbox"/> Restraint System <input type="checkbox"/> Positioning System <input type="checkbox"/> Aerial Lift/Work Platforms																																		
29. Can Rescue Be Performed if Required:		30. Type of Rescue:		27c. Other Fall Protection Methods:																																	
30a. Explain Other:																																					
31. Do You Have a Written Rescue Plan:		32. Are End Users Trained on Fall Arrest System:		33. Do Swing Fall Hazards Exist:	34. Is End User Refresher Training Conducted as Per OPNAVINST 5100.23G:																																
RISK ASSESSMENT CODE (RAC): 1= CRITICAL																																					
CATEGORY 1 - The hazard may cause death, loss of facility/asset or result in grave damage to national interests. CATEGORY 2 - The hazard may cause severe injury, illness, property damage, damage to national or service interests or degradation to efficient use of assets. CATEGORY 3 - The hazard may cause minor injury, illness, property damage, damage to national service or command interest or degradation to efficient use of assets. CATEGORY 4 - The hazard presents a minimal threat to personnel safety or health, property, national, service or command interests or efficient use of assets.				 <table border="1" style="margin-left: auto; margin-right: auto;"> <thead> <tr> <th colspan="2" rowspan="2"></th> <th colspan="4" style="text-align: center;">Probability of Occurrence</th> </tr> <tr> <th style="text-align: center;">Likely</th> <th style="text-align: center;">Probably</th> <th style="text-align: center;">May</th> <th style="text-align: center;">Unlikely</th> </tr> </thead> <tbody> <tr> <th rowspan="4" style="writing-mode: vertical-rl; transform: rotate(180deg);">SEVERITY</th> <th style="text-align: center;">A</th> <th style="text-align: center;">1</th> <th style="text-align: center;">1</th> <th style="text-align: center;">2</th> <th style="text-align: center;">3</th> </tr> <tr> <th style="text-align: center;">B</th> <th style="text-align: center;">1</th> <th style="text-align: center;">2</th> <th style="text-align: center;">3</th> <th style="text-align: center;">4</th> </tr> <tr> <th style="text-align: center;">C</th> <th style="text-align: center;">2</th> <th style="text-align: center;">3</th> <th style="text-align: center;">4</th> <th style="text-align: center;">5</th> </tr> <tr> <th style="text-align: center;">D</th> <th style="text-align: center;">3</th> <th style="text-align: center;">4</th> <th style="text-align: center;">5</th> <th style="text-align: center;">5</th> </tr> </tbody> </table> <p style="text-align: center; color: red; font-weight: bold;">Risk Levels</p>					Probability of Occurrence				Likely	Probably	May	Unlikely	SEVERITY	A	1	1	2	3	B	1	2	3	4	C	2	3	4	5	D	3	4	5	5
		Probability of Occurrence																																			
		Likely	Probably	May	Unlikely																																
SEVERITY	A	1	1	2	3																																
	B	1	2	3	4																																
	C	2	3	4	5																																
	D	3	4	5	5																																

5.10.2 Sample Aviation Fall Protection and Prevention Plan (Form)

FALL PROTECTION AND PREVENTION PLAN		<input type="button" value="E-Mail"/>
<i>To be completed by the Competent Person (CP), Qualified Person (QP), or Program Manager (Aviation)</i>		
GENERAL INFORMATION		
1. Activity/Command Name:		2. Date:
3. Hangar/Facility Number:	4. Detailed Location:	
5. Plan Prepared By (Name, Title, code):		
6. Date Fall Protection and Prevention Plan Modified/Implemented:	<input type="button" value="Add Date Field"/>	<input type="button" value="Remove Date Field"/>
Date Plan was Modified:	Date This Modification Implemented:	
Date Plan was Modified:	Date This Modification Implemented:	
Date Plan was Modified:	Date This Modification Implemented:	
7. Task/Wok Description:		
8. Name(s) of Personnel Exposed to Fall Hazards:		
		<input type="button" value="Add Name Field"/>
		<input type="button" value="Remove Name Field"/>
ANCHORAGE(S)		
9. Anchorage Location:	10. Anchorage Strength:	
TRAINING		
11. Fall Protection Program Manager training Completed::	12. End User Training Completed:	
13. Description of the Fall Protection System to be used:		
14. Free Fall Distance:	15. Total Fall Distance:	
16. Description of Anchorage(s):		
17. Other Systems Used:		
Description of Other System Used:		<input type="button" value="v"/>
18. Special Pre-Use Instructions::		
19. Special Post-Use Instructions:		

August, 2013

15.10.3 Sample Site-Specific Fall-arrest Rescue Plan

SITE-SPECIFIC FALL ARREST RESCUE PLAN		<input type="button" value="E-Mail"/>	
GENERAL INFORMATION			
1. Activity/Command Name:		2. Date:	
3. Hangar/Facility Number:	4. Phone:		
5. Detailed Location:			
6. First Aid Kit Location(s):	<input type="button" value="Add Location Field"/>	<input type="button" value="Remove Location Field"/>	
1:			
2:			
3:			
7. Fire Extinguishert Location(s):	<input type="button" value="Add Location Field"/>	<input type="button" value="Remove Location Field"/>	
1:			
2:			
3:			
8. Ladder/Lift Location:			
9. Nearest Medical Facility:			
10. Procedures for Requesting Rescue:	<input type="button" value="Add Procedure Field"/>	<input type="button" value="Remove Procedure Field"/>	
1:			
2:			
3:			
4:			
5:			
11. Describe Rescue Operation and Method:			
12. Types of Equipment used (<i>Ladder, Holst, Aerial Lift, etc.</i>):			
13. Specialized Training for the Rescue Team:			
14. Has Rescue Plan Been Developed in Coordination with Local Emergency Services (<i>Essential if relying on them to provide rescue</i>):			
15. Additional Comments:			
16. Prepared By (<i>Name, Title, Code</i>):			
17. Date Fall Arrest Plan Approved:	18. Printed Name, Title, Code of FFPM::	19. Signature Date:	20. Signature of FFPM:

15.11 Common Types of Aviation Fall Protection Options

Overhead Beam Strap with Self-Retracting Lanyard



August, 2013

Portable Fall-Arrest System



August, 2013

Horizontal Life-Line



Vacuum System (for large, aluminum aircraft)

(Note: Cranial Protection also must be worn)



Fully-Guarded “B” Stand



End of Section

August, 2013

16.0 FALL PROTECTION REQUIREMENTS FOR ARCHITECTS, ENGINEERS AND OTHER INSPECTORS CONDUCTING ROOF INVESTIGATION, ASSESSMENT AND INSPECTION WORK

16.1 BACKGROUND

Roof systems can deteriorate from normal wear; severe weather conditions (e.g., wind and snow loads); building movement (e.g., settlement, material contraction and expansion); improper design, construction, and maintenance. Any roof repairs not dealt with after the first signs of failure can result in increased damage to the building envelope and interior finishes, and loss of occupant productivity, if damage causes interruption in services and program delivery. Failure of structural integrity can endanger the safety of building occupants. Investigation, assessment and inspection are required to determine the condition of the roof.

16.2 PURPOSE

The purpose of this chapter is to provide instructions, requirements, and guidance for roofing investigation, assessment, or inspections in a safe manner. This instruction does not apply to safety procedures for performing work on roofs by Public works/Facilities personnel and or roofing contractors. It only applies to inspecting, investigating, or assessing existing roof systems or conducting fall hazard surveys where there is no construction work in progress. For safety requirements regarding roof construction see EM 385-1-1, Section 21 Fall Protection, Unified Facilities Guide Specifications(UFGS) Section 01 35 29.05 20 "Safety and Occupational Health Requirements for Design Build", and UFGS 01 35 29 Governmental Safety Requirements for Design Bid Contracts. For safety requirements for conducting maintenance work on roofs see OPNAVINST 5100.23 Series, 29 CFR 1910 Subpart D and 29 CFR 1910, Notices of Proposed Rulemaking dated 24 May 2010. This checklist in paragraph 16.13 is provided as a guide for safety procedures during roof inspection, assessment, and investigation, to protect DON personnel from unexpected fall hazards from heights (or on the same level). This checklist may be modified as required by the qualified DON Engineer, Architect or other inspectors responsible for each specific project, after consultation with the Command or Installation Safety Office.

Regular inspection of building roof systems can lead to early detection of roof problems, protection of Government capital assets, and maintenance of safe working environments for building occupants.

16.3 OBJECTIVES

Protection of DON architects/engineers and other inspectors when accessing roofs to conduct investigation, assessment and inspection tasks to determine whether or not the roof system is performing according to its intended function, and to identify signs of weakness or, deterioration, , for the purpose of scheduling needed repairs or replacement of roofing material.

16.4 RESPONSIBILITIES

It is the responsibility of each individual performing roofing investigation, assessment, and inspection, to insure that he or she understands and fully complies with all required safety instructions, and has the proper safety equipment specified by this guidance, or by the project manager. The inspection and investigation work shall be conducted by more than one individual. The head of the inspection team is responsible for verifying with the Command safety office at each activity to determine whether or not there are additional relevant local safety instructions and/or requirements, and for relaying that information to all team members. The cooperation of each individual is vital to the success of the safety program. Inspectors are responsible for their own safety, and always should be alert to hazards caused by others. If work cannot be performed safely, the inspection and investigation work shall not proceed until provisions have been made to conduct the work in a safe manner. Each inspector should keep in mind these basic duties and responsibilities for being safe during inspection and investigation work:

- a. Observe all safety rules.
- b. Work in accordance with established safety procedures.
- c. Report unsafe conditions and practices to the appropriate supervisor.
- d. Conduct work activities in a manner that will not endanger oneself or others.
- e. Assist new employees in safely carrying out their job duties.
- f. Report injuries immediately to the supervisor.
- g. Undertake only those jobs that you understand.

16.5 SAFE WORK PRACTICES

16.5.1 General/Minimum Requirements

- a. Do not access or work on a roof unless trained appropriately.
- b. Review the Fall Hazard Survey Report for the roof which has been developed by the building owner or other personnel to ensure that a proper risk assessment has been completed before accessing and/or commencing any work on roofs.
- c. Ensure that an additional roof risk assessment has been completed when accessing and working on roof during adverse weather conditions (i.e. wind, rain, excessive heat, etc).
- d. Ensure that you wear the following personal protective equipment at all times: roof shoes, sunscreen, sunglasses.
- e. Ensure that Public Works/Facilities personnel and the Command Safety Office are aware of your presence/work on the roof and the expected time frame.
- f. Do not work on a roof alone – always work in pairs.
- g. Ensure that you have a form of communication link with safety office.
- h. Roof areas should be tidy and clean; where rubbish or stacked material interferes with ascending and performing inspection work of the roof, do not proceed until it is safe to perform the work.
- i. Ensure that there is a safe method of access to the roof and that this method is used. Ensure that all ladders are safe and any erected scaffolding is certified and safe.

August, 2013

- j. Ensure that there is a safe method of transporting any needed equipment to the roof work area.
- k. Make sure of the structural soundness of the roof and frame before a person walks on a roof.
- l. Be familiar with the Emergency Rescue Response Procedure and the Command fall hazard rescue plan.
- m. Flat Roofs: Personnel conducting inspection on roofs shall not proceed to within 6 feet of the edge. If work is to be done within 6 feet of the edge, appropriate safety precautions shall be taken to minimize the risk of falling (e.g., elevating work platforms, scaffolding, temporary guardrails, Fall-arrest System, positioning, or restraint).
- n. Pitched Roofs: Where a roof has a pitch of more than 4 in 12, where if someone fell they would roll off the roof, or the roof is deemed to be too slippery, or too fragile, then work must be carried out only by use of one or more of the following: Elevating Work Platform, Scaffolding, Guardrails (not appropriate for pitches exceeding 45 degrees), or Roof Ladder (in conjunction with other devices, e.g., fall-arrest system).

16.6 SAFE ACCESS

16.6.1 Portable Ladder Safety

- a. Use only OSHA compliant ladders.
- b. Only one person may be on the ladder at any time. One person should secure the ladder while another is climbing.
- c. **Ladder must extend a minimum of 3 – 3 ½ feet above roof edge.**
- d. **Ladder must be properly secured to roof edge immediately after initial ascent.**
- e. Maintain appropriate ladder slope as outlined by OSHA (One foot of run for every four feet of rise).

16.6.2. Portable Ladder Work Practices.

- a. Do not exceed the weight limit of the ladder.
- b. When ascending or descending, the climber must face the ladder.
- c. Portable rung and cleat ladders shall be used at such a pitch that the horizontal distance from the top support to the foot of the ladder is one-quarter of the working length of the ladder (the length along the ladder between the foot and the top support).
- d. The ladder shall be so placed as to prevent slipping, or it shall be lashed, or held in position. The ladder base section must be placed with a secure footing.
- e. Employees shall equip all portable rung ladders with non-slip bases when there is a hazard of slipping. However, non-slip bases are not intended as a substitute for care in safely placing, lashing, or holding a ladder used on oily, metal, concrete, or slippery surfaces. These non-slip bases can be obtained from the Project Supervisor.
- f. The top of the ladder must be placed with the two rails supported, unless equipped with a single-support attachment.
- g. On two-section extension ladders, the minimum overlap for the two sections in use shall be according to OSHA specifications.
- h. Portable rung ladders with reinforced rails shall be used only with the metal reinforcement on the underside of the rails.

August, 2013

- i. The bracing on the back legs of step-ladders is designed solely for increasing stability, and not for climbing.
- j. Ladders shall not be:
 - 1) Used in a horizontal position as platforms, runways, or scaffolds.
 - 2) Placed in front of doors opening toward the ladder, unless the door is blocked open, locked, or guarded.
 - 3) Placed on boxes, barrels, or other unstable bases to obtain additional height.
 - 4) Tied or fastened together to provide longer sections. They must be equipped with the hardware fittings necessary if the manufacturer endorses extended uses.
 - 5) Used to gain access to a roof, unless the top of the ladder extends at least 3 feet above the point of support at eave, gutter, or roofline.
 - 6) Used as a brace, skid, guy, gin pole, gangway, or for other uses than that for which they were intended, unless specifically recommended for use by the manufacturer.
- k. No more than one person at a time shall use a ladder.
- l. Ladder jacks and scaffold planks, where use by more than one person is anticipated, shall utilize specially-designed ladders with larger dimensions of the parts procured from the Project Supervisor. Ladders with broken or missing steps, rungs, or cleats, broken side rails, or other faulty equipment, shall not be used. Employees finding ladders with any of these conditions shall report them to the Project Supervisor. Improvised repairs shall not be made.
- m. Ladders made by fastening cleats across a single rail shall not be used.
- n. Tops of ordinary step-ladders shall not be used as steps.
- o. Middle and top sections of sectional or window cleaners' ladders shall not be used for bottom sections, unless the user equips them with safety shoes.

Note: For additional portable ladder work practices and requirements, see paragraph 9.12.2

16.6.3 Fixed Ladder Safety Practices

See Paragraph 9.12.1

16.6.4 CONTROL ZONES ON ROOFS

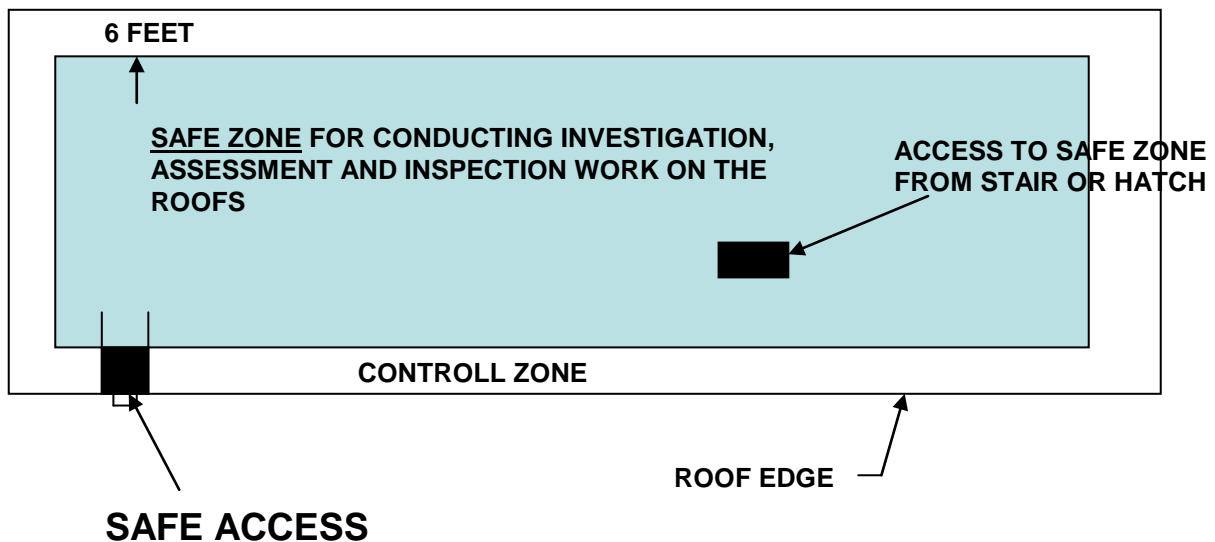

When conducting investigation, assessment or investigation work within the 6 feet from the unprotected edge of the roof, a fall protection method is required. See reference 1.1, Navy FP Guide for Ashore Facilities.

16.7 ADDITIONAL PROTECTIVE MEASURES

- a. All inspectors shall wear proper clothing. Hard hats shall be worn at the site for all roofing construction projects and OSHA roof construction safety requirements shall be followed.
- b. Check ladders before use to insure they are safe, in good working order, extend at least 3 rungs above the roof edge, are properly secured, and are installed at proper slope.
- c. Drinking alcoholic beverages on the job, reporting to work intoxicated or being under the influence of drugs is strictly forbidden and not allowed on any construction site.
- d. During hot weather, be particularly aware of heat exhaustion and heat stroke symptoms. Employees should drink water frequently and get out of the sun if they become dizzy. During cold weather, be aware of hypothermia and frostbite symptoms. Employees should dress warmly (in layers), warm up frequently, and stay dry.

16.8 PRE-WORK CHECK

Prior to beginning the investigation, assessment and inspection work in any area or on any equipment where fall hazards exist, a pre-work check must be completed that includes the following items:

- a. Ladders:

August, 2013

- 1) Gripping safety feet in place and secure on ladders.
 - 2) Wooden ladders are sound and in good working order.
 - 3) All parts and fittings on ladders are secure.
 - a) Non-slip surfaces are in place on ladder rungs.
 - b) When setting ladder up, footing of ladder is secure on a firm, level, and non-skid surface and top of ladder is placed against a solid, stationary object.
 - c) All ladders meet OSHA specifications for design and safety.
 - d) Check for unsafe ladder condition.
- b. Floor & Wall Openings: All floor and wall openings (such as open roof access hatches or opening including skylights due to ongoing construction or repair work) are safely covered or blocked from access. If not safely covered and blocked from access, the opening shall have someone assigned for constant attendance to it.
- c. Roof Condition:
- 1) Verify that the slope does not exceed 4 inches per foot. If the slope is more than 4 inches per foot, the use of fall protection equipment is required
 - 2) Conduct interviews with local personnel familiar with the roof construction and visual inspection of roof structural deck underside to identify potential safety issues with the deck.
 - 3) Ensure that the roof surface is not slippery due to water, algae, dirt, and debris that would preclude firm footing.
- d. Weather:
- 1) Check the current weather to insure that none of the conditions listed above exist.
- e. Work Procedures: If any one of the conditions described in Pre-Work Check list is not met for the area or piece of equipment to be inspected and posing a potential fall hazard, then employees may not perform that work until the condition is corrected. If the condition cannot be remedied immediately, a supervisor or Project Manager must be notified of the problem. If the situation calls for use of fall protection equipment such as harnesses or lanyards because the fall hazard cannot be reduced to a safe level for roof inspection, then the employee shall utilize the normal safety procedures as per the local safety officer.

16.9 INSPECTION PROCEDURES

An inspection team shall typically consist of a minimum of two individuals. One individual shall be designated as a safety monitor/recorder and assist the inspector by maintaining visual and verbal contact at all times during the inspection. The other shall conduct the actual inspection as per the specifics of the job. Inspection personnel shall conduct themselves in a manner that does not endanger themselves and members of the inspection team.

August, 2013

16.10 FALL PROTECTION and PREVENTION

All team members shall maintain a safe distance from all roof edges at all times (6 feet minimum) unless being observed and assisted by the designated safety monitor and the proper fall protection is provided at the control zone.

When equipment used to conduct the roof inspection presents a hazard while ascending and accessing the roof, the inspector shall not carry the equipment. Instead, the equipment shall be transferred to the roof by rope or other means.

16.11 TRAINING REQUIREMENTS

Architects/Engineers and other inspectors shall be trained prior to ascending roofs of existing buildings and facilities for the purpose of conducting inspection, investigation and assessment of roofing system. This training is available on Enterprise Safety Application Management System (ESAMS) Web based training course #3639.

At a minimum, all personnel conducting investigation, assessment and inspection work shall receive ESAMS training course #1259 titled Slips Trips and Falls. If inspection work is required in the control zone (within 6 feet from the edge of the roof), and personal protective equipment is used additional training is required on the safe use of the equipment. Personnel using personal fall protective equipment are required to receive ESAMS Course # 2018 titled End-user training and also the Hands-On Training (ESAMS Course #3042). This training is also available at E-Learning (Course # xxx) and Navy Knowledge Online (NKO), Course # xxx.

16.12 REFERENCES:

16.12.1. OPNAVINST 5100.23 Series: Navy Safety and Occupational Health (SOH) Program manual

16.12.2. Navy Fall Protection Guide for Ashore Facilities (latest edition)...

16.12.3. 29 CFR 1926.500: Fall Protection in Construction.

16.12.4. 29 CFR 1910: Occupational Safety and Health Standards for General Industry

16.12.5. 29 CFR 1910: Notices of Proposed Rulemaking dated 24 May 2010.

16.12.6. MCO 5100.29 Series: Marine Corps Safety Program.

16.12.7. NAVMC DIR 5100.8: Marine Corps OSH Program Manual

End of Section

16.13: CHECK-LIST FOR ARCHITECTS, ENGINEERS AND OTHER INSPECTORS INVOLVED IN ROOF INSPECTION AND INVESTIGATION WORK
 (Must be completed prior to accessing the roof)

COMMAND/ACTIVITY _____
 Building Number: _____

CATEGORY	ITEM	YES	NO	N/A	COMMENTS [If 'No', provide an explanation]
GENERAL					
TEAM MEMBERSHIP	The team shall consist of more than one person. Does the inspection team consist of more than one person?				
PURPOSE OF ROOF INVESTIGATION AND INSPECTION	Is the purpose of the investigation and inspection to determine problems with the roof itself?				
TYPE OF ROOF	Is the roof flat or minimally sloped? If the roof is steep or has a slope of more than 4/12, Fall protection equipment/system is required to perform the inspection/investigation work. A complete fall protection program shall be in place.				
COMMAND SAFETY OFFICE	Has the inspection team contacted the safety office for permission to ascend the roof and perform inspection/investigation work? (Is there any work currently being conducted on the roof?)				
RESPONSIBILITIES AND BASIC DUTIES OF THE INSPECTION AND INVESTIGATION TEAM					

DEPARTMENT OF THE NAVY FALL PROTECTION GUIDE FOR ASHORE FACILITIES

August, 2013

AWARENESS OF FALL HAZARDS ENCOUNTERED ON THE ROOF	Does the roof have an unprotected edge (The edge protection is less than 39 inches high)? If so, all team members shall be aware of fall hazards encountered on the roof.				
FALL HAZARDS ENCOUNTERED ON THE ROOF	Do all team members have the proper knowledge and awareness of all hazards encountered on the roof? Fall hazards may include falls from unprotected edges, holes/hatches, openings, skylights, trips and slips on the same level, etc.				
COMPLIANCE WITH SAFETY INSTRUCTIONS AND REQUIREMENTS	Do all team members understand the compliance requirements of all safety rules? Team members shall observe all safety rules and work w/established safety procedures.				
UNSAFE CONDITIONS AND PRACTICES	Are there any existing unsafe conditions or practices being conducted on the roof? Report any unsafe conditions or practices to your supervisor and the Command safety office.				

SAFE WORK PRACTICES					
----------------------------	--	--	--	--	--

FP TRAINING	Did all team members receive the appropriate FP training for performing roof inspections/investigation work?				
SITE SPECIFIC ROOF HAZARD SURVEY REPORT	Was the roof hazard survey report developed by the building owner and/or others, reviewed by the inspection team prior to ascending and/or commencing any work on the roof?				
ASCENDING THE ROOF DURING ADVERSE WEATHER CONDITIONS	Was any additional risk assessment performed due to adverse weather conditions?				
PERSONAL PROTECTIVE EQUIPMENT	Are all team members wearing the proper PPE for conducting roof inspection (i.e. proper footwear)?				
ROOF CONDITION	Is the roof area tidy and clean with no rubbish or stacked material that may interfere with the access and/or performance of inspection/investigation?				
LADDERS AND SCAFFOLDS USED FOR ACCESS	Is the ladder/scaffold used for access safe and certified?				

DEPARTMENT OF THE NAVY FALL PROTECTION GUIDE FOR ASHORE FACILITIES

August, 2013

TRANSPORTING EQUIPMENT OR TOOLS TO THE ROOF AREA	Is there a safe method for transporting equipment or tools to the roof that may be needed for the performance of the roof inspection/investigation?				
STRUCTURAL INTEGRITY OF THE ROOF	Is the roof surface structurally sound for the team members to walk on and perform inspection work safely?				
EMERGENCY RESCUE RESPONSE PROCEDURE AND COMMAND FALL HAZARD RESCUE PLAN	Is the team familiar with the rescue procedures?				
WORKING ON FLAT ROOF OR MINIMALLY SLOPED ROOFS	The inspection team shall stay at least 6 feet away from the unprotected edge of the roof. Is there a need to perform work within the 6 feet of the unprotected edge? If the answer is yes, the team must use other fall protection alternatives (i.e. fall protection equipment).				
WORKING ON PITCHED ROOF WITH MORE THAN 4/12 SLOPE	For a roof with a slope of more than 4/12, are other fall protection alternatives provided to perform the inspection/investigation work safely?				
SAFE ACCESS					
PORTABLE LADDER SAFETY	Are the team members familiar with the safety requirements for ascending and descending the ladder? This may include how to secure the ladder, proper slope and how to safely ascend the roof.				
ASCENDING PITCHED ROOF USING PORTABLE LADDER	When the roof has a pitch of more than 4/12 or is too slippery or fragile, the inspection/investigation work performed may require the use of an elevated work platform, scaffolding or other alternative. Is the slope of the roof more than 4/12, or is the roof too slippery or fragile?				
ASCENDING THE ROOF USING FIXED LADDERS	Is the fixed ladder longer than 20 feet? If ladder is longer than 20 feet, ladder-climbing device or self retracting lanyard is required for access.				
FIXED LADDERS LONGER THAN 20 FEET	If ladder is equipped w/ladder climbing device, are all team members trained on the safe use of a ladder-climbing device?				

DEPARTMENT OF THE NAVY FALL PROTECTION GUIDE FOR ASHORE FACILITIES

August, 2013

ACCESS TO ROOF THRU A HATCH	After ascending the roof, is there a method for protecting the hatch when it is left open? If not, then close the hatch immediately after access.				
PROTECTIVE METHODS FOR CONDUCTING INSPECTION AND INVESTIGATION WORK SAFELY					
SAFE ZONE	After gaining access to the roof, is the inspection/investigation work required to be performed on a roof more than 6 feet away from unprotected roof edge? If so, inspection/investigation work can be performed in the safe zone without the use of fall protection equipment.				
CONTROL ZONE	Is the inspection/investigation work required to be performed within 6 feet of unprotected roof edge? If so, a fall protection method is required.				
DESIGNATED AREA	Is there a need to inspect mechanical equipment on roofs? For inspection of mechanical equipment on roofs, a designated area is required to be established on the roof to be located at a minimum 6 feet away from the unprotected roof edge including a 100% transition from the fixed ladder to the designated area.				
ADDITIONAL PROTECTIVE MEASURES	Are all the team members knowledgeable on the safe use of portable ladders? A portable ladder shall be in good working condition, have enough length to extend more than 3 feet above the roof edge and secured properly.				
PRE-WORK SAFETY VERIFICATION CHECK					
SAFETY VERIFICATION	Has safety verifications been performed on ladders, floor or wall openings, work practices and roof? Have weather conditions been considered and verified?				
ADDITIONAL TRAINING					
SLIPS TRIPS AND FALLS TRAINING	In addition to the A/E's training for conducting inspection work on roofs, have all team members received Slips, Trips and Falls training?				

End of Section

17.0 OTHER FALL PROTECTION MEASURES

17.1 BARRICADE AREA

All areas must be barricaded to safeguard employees. When working overhead, barricade the area below to prevent entry by unauthorized employees. A distance of six feet shall be barricaded around the worker.

17.2 WARNING TAPES/SIGNS

Construction warning tape and signs shall be posted so they are clearly visible from all possible access points. When a sign is used, it should clearly indicate the entry requirements, potential hazards, and personal protective equipment requirement.

17.3 HARD HAT/HARD CAP REQUIREMENTS

Hard hats/ hard caps must comply with ISEA Z89.1, 1997 Type I, Class E & G and shall be required when workers are exposed to falling/flying objects. Furthermore, select one additional measure:

Hard hats/Hard caps must be worn any time that employees are working below other employees and/or the potential exists for falling objects to strike the employees working below. In addition to hard hats, one additional preventive measure must be implemented.

For example, when using hard hats/hard caps, the employee must use additional form(s) of protection from falling objects, such as: barricading the area or employing protective canopy structures or platforms with toe boards.

17.4 CLOTHING AND SAFETY SHOES

Suitable clothing shall be worn. Sufficient and proper clothing shall be worn to assist in preventing scratches, abrasions, slivers, sunburn, or similar hazards. Loose or ragged clothing or ties shall not be worn while working around moving machinery. At a minimum, employee must wear a short-sleeved shirt and long trousers.

Employees shall wear substantial footwear made of leather or other equally firm material whenever there is a danger of injury to the feet from: falling or moving objects, or from burning, cutting, penetration, or similar hazards. The soles and heels of such footwear shall be of a material that

August, 2013

will not create a slipping hazard. Footwear that has deteriorated to the point where it does not provide the required protection shall not be used.

17.5 EVACUATE AREA BELOW

All non-essential personnel below a construction area must be cleared or protection provided.

17.6 SECURE THE STORED MATERIAL

All construction materials and equipment stored on a roof or other exposed areas must be secured against inclement weather conditions. Before the end of the workday, all loose materials must be secured to prevent injury or property damage from falling objects. Caution must also be taken not to overload the roof. Materials shall not be stored within six feet of the edge of the roof unless guards are erected on the roof edge.

17.7 TRAFFIC CONTROL

Where working over or adjacent to a roadway, traffic control measures must be implemented. Employees working adjacent to roadways must wear vests that are highly visible, and have reflective markings. Where working adjacent to transportation aisles, traffic control measures should be reviewed to ensure the safety of the personnel on the job site.

17.8 CONTROL FALLING OBJECTS

Where employees are working over other employees, all tools and equipment shall be secured so that they will not fall. Tethers should be used to tie off tools and equipment. Employees must wear hard hats whenever there is a potential for falling objects. Toe boards and solid floor surfaces without any openings shall be provided to prevent objects from falling through the openings.

17.9 DEBRIS CONTROL

Measures shall be taken to control debris in the construction area. Debris shall not be allowed to accumulate on walking/working surfaces.

17.10 RADIO COMMUNICATION OR SAFETY MONITOR

Wherever work is performed on a roof, lift, or other area where potential for falls exists, a safety monitor or two-way radio communication is recommended.

17.11 SAFETY COMMUNICATIONS

Establish/maintain contact/communication with your Activity Safety Manager or competent person wherever roof top work is being performed and the possibility of adverse weather conditions exist.

17.12 LOCK-OUT/TAG-OUT/TRY-OUT

Where working near energy sources, lock-tag/try-out must be used to eliminate any potential hazards.

17.13 CRANE RAIL STOPS

Implement the crane rail stops as mandated by the Activity WHE-certifying official.

17.14 CATCH PLATFORM (Falling Object Protection)

A substantial catch platform shall be installed below the working area of roofs more than 20 feet from the ground to eaves with a slope greater than 4 in 12 (vertical to horizontal and without a parapet). The platform shall extend 2 feet in width beyond the projection of the eaves, and shall be provided with a safety rail, mid rail, and toe-board. This provision shall not apply to workers engaged in work upon such roofs who are protected by a harness attached to a lifeline.

Where work is in progress above workers, a catch platform or other means shall be provided to protect those working below. All workers shall be notified. One completed floor shall be maintained between workers and steel or concrete work above.

Requirements

- (1) A catch platform shall be installed within six vertical feet of the work area.
- (2) The width of the catch platforms shall equal the distance of the fall, but shall be a minimum of 45 inches wide. The catch platforms shall be equipped with standard guard on all open sides.

17.15 EGRESS FALL PROTECTION

Wherever a fall hazard of 4 feet or greater is encountered by employees moving from one elevated area to another, fall protection shall be provided (for example, utilizing a scissors lift to gain access to a roof or intermediate platform; the employee must be protected when exiting the scissors lift). This can be accomplished by using a double lanyard or a "Y" lanyard. One hundred percent fall protection is required at all times.

18.0 AMERICAN NATIONAL STANDARDS INSTITUTE, ANSI Z359 FALL PROTECTION CODE/STANDARDS

ANSI is responsible for the development of voluntary consensus standards in the United States. The collection of several ANSI Z359 fall protection standards is termed “Fall Protection Code”. Originally The American National Standards Institute ANSI Z359 Committee developed ANSI Z359.1 as personal fall-arrest system standard. All the testing and criteria was based on complete fall-arrest systems rather than components. In order to harmonize the US FP standards with ISO, Europe, Canada, etc., ANSI is changing the system standards to equipment/component standards. Every component shall have its own standard (i.e. Harnesses, Connectors, etc.) When all product/component standards are finalized and published, ANSI Z359.1 standard will become a reference (historical) document. Eventually there will be 18 fall protection standards as part of the FP Code.

18.1 Completed and Published ANSI Z359 FP Standards

- ANSI Z359.0 Definitions and Nomenclature Used for Fall Protection and Fall-arrest
- ANSI Z359.1 Safety Requirements for Personal Fall-arrest Systems, Subsystems and Components
- ANSI Z359.2 Minimum Requirements for a Comprehensive Managed Fall Protection Program
- ANSI Z359.3 Safety Requirements for Positioning and Travel Restraint Systems
- ANSI Z359.4 Safety Requirements for Assisted- Rescue and Self Rescue Systems, Subsystems and Components
- ANSI Z359.06 Specifications and Design Requirements for Active Fall Protection Systems
- ANSI Z359.7 Certification Testing of Fall Protection Products
- ANSI Z359.12 Connecting Components for Personal Fall-arrest Systems
- ANSI Z359.13 Personal Energy Absorbers and Energy Absorbing Lanyards;
- ANSI Z359.14 Requirements for Self Retracting Devices

18.2 ANSI Z359 Fall Protection Standards under Development

August, 2013

- ANSI Z359.5 Not Selected
- ANSI Z359.8 Requirements for Suspended Rope Access
- ANSI Z359.9 Safety Requirements for Descent Control Devices
- ANSI Z359.10 Not selected
- ANSI Z359.11 Safety Requirements for Full Body Harnesses
- ANSI Z359.15 Requirements for Single Anchor Vertical Lifelines and fall-arrestors
- ANSI Z359.16 Safety requirements for Climbing Ladder Fall-arrest Systems
- ANSI Z359.17 Safety Requirements for Horizontal Lifelines for PFAS
- ANSI Z359.18 Requirements for Anchorage Connectors for PFAS

End of Section

19.0 REFERENCES

- 19.1 29 CFR 1926.500, Subpart M, Fall Protection in the Construction Industry.**
- 19.2 29 CFR 1910, Occupational Safety and Health Standards.**
 - 19.2.1 29 CFR 1910 Walking-Working Surfaces and Personal Protective Equipment (Fall Protection Systems); Proposed Rule**
- 19.3 29 CFR 1915.159, Personal Fall-arrest Systems.**
- 19.4 US Department of Labor, OSHA 3124 1993 (Revised) Stairways and Ladders.**
- 19.5 US Department of Labor, OSHA Instruction Standards, 3.1, December 1995, Interim Fall Protection Compliance Guidelines for Residential Construction.**
- 19.6 American National Standard Institute ANSI Z359, Fall Protection Code/Standards**
- 19.7 Introduction to Fall Protection, J. Nigel Ellis, PHD, CSP, PE, (Third Edition: American Society of Safety Engineers).**
- 19.8 US Army Corps of Engineers (USACE), Safety and Health Requirements Manual, EM 385-1-1, current edition.**
- 19.9 NAVFAC P300: Management of civil Engineering Support Equipment**
- 19.10 NAVMC DIR 5100.8, Marine Corps Occupational Safety and Health Program Manual, Chapter 8**
- 19.11 MCO 5100.29 Series, Marine Corps Safety Program**

HOW TO OBTAIN INFORMATION

- 1. OSHA Regulations/Standards from OSHA Web Page: <http://www.osha.gov/>**
- 2. DoD employees can acquire at no cost the Construction Criteria Base (CCB) from the National Institute of Building Sciences. CCB is an electronic collection of over 10,000 documents used in building design and construction, including guide specifications, manuals, handbooks, regulations, reference standards and other essential design and construction criteria documents. CCB comprises multiple CDs covering Codes of Federal Regulations, OSHA Standards, Specifications, DOD Manuals**

August, 2013

and Design Criteria and other relevant information. These CDs are updated quarterly. The P.O.C for Navy employees to order the CCB CDs is:

The CCB website can be accessed at: <http://www.wbdg.org/ccb/ccb.php> Specifications can also be downloaded from the SpecsIntact website (with helpful links, including the CCB website) at:

<http://specsintact.ksc.nasa.gov/>

3. To acquire “Introduction to Fall Protection” (Third Edition) by Dr. Nigel Ellis, Ph.D., the handbook can be purchased for approximately \$85 plus shipping and handling from:

American Society of Safety Engineers (ASSE)

1800 East Oakton Street

Des Plaines, IL 60018-2187

Phone: (847) 699-2929

4. ANSI Standards can be purchased from ASSE at the above address.

5. This Guide can be found at the following Web Sites:

https://portal.navfac.navy.mil/portal/page/portal/navfac/navfac_ww_pp/navfac_hq_pp/navfac_sf_pp/navfac_sf_fall/tab109972/fall%20protection%20guide%2015%20february%202012.pdf

http://www.public.navy.mil/navsafecen/Documents/OSH/FP/Shore_FP_Guide.pdf

Prepared By:

Navy Fall Protection Working Group

For Questions/comments contact:

Basil Tominna, P.E.

Naval Facilities Engineering Command

1220 Pacific Highway

San Diego, CA 92132-5190

Phone: Commercial (619) 5332-3041, DSN 522-3041

Email: basil.tominna@navy.mil

August, 2013

Appendix A

FALL PROTECTION REQUIREMENTS COMPARISON AMONG VARIOUS OSHA STANDARDS, NAVY and EM-385 REQUIREMENTS

Requirements	Navy FP Chapter 13 of OPNAVINST 5100.23 Series and Fall Protection Guide for Ashore Facilities Marine Corps Chapter 18, of NAVMC DIR 5100.8, Fall Protection Program	29 CFR 1910 General Industry Standard OSHA Notices of Proposed Rulemaking Requirements of March 2010 Subpart D and I	USACE EM385-1-1 (2013) Section 21 Fall Protection	29 CFR 1926 Construction Standard
Threshold Height FP is required	<ul style="list-style-type: none"> Above 4 feet 	<ul style="list-style-type: none"> Above 4 feet 	<ul style="list-style-type: none"> Contractors - Above 6 feet USACE- Personnel – Above 4 ft 	<ul style="list-style-type: none"> Above 6 feet
Development of Fall Protection Program	<ul style="list-style-type: none"> Each Activity which has personnel exposed to fall hazards shall establish a managed fall protection program. Navy Activities shall conduct fall hazard surveys and prepare survey reports. Navy Activities shall prepare a site specific Fall Protection & Prevention Plan (FP&PP). The FP & PP shall be developed 	<ul style="list-style-type: none"> Not addressed 	<ul style="list-style-type: none"> Contractors having personnel working at heights, exposed to fall hazards and using FP equipment shall develop a site specific Fall Protection and Prevention Plan (FP&PP) and submit it to GDA for review and acceptance as part of APP. USACE-Owned Facilities having personnel working at heights are required to develop a written FP program and a site specific FP&PP. Each USACE-Owned facility shall conduct a Fall 	<ul style="list-style-type: none"> Not addressed

DEPARTMENT OF THE NAVY FALL PROTECTION GUIDE FOR ASHORE FACILITIES

August, 2013

Requirements	<p>Navy FP Chapter 13 of OPNAVINST 5100.23 Series and Fall Protection Guide for Ashore Facilities</p> <p>Marine Corps Chapter 18, of NAVMC DIR 5100.8, Fall Protection Program</p>	<p>29 CFR 1910</p> <p>General Industry Standard OSHA Notices of Proposed Rulemaking Requirements of March 2010</p> <p>Subpart D and I</p>	<p>USACE EM385-1-1 (2013)</p> <p>Section 21 Fall Protection</p>	<p>29 CFR 1926</p> <p>Construction Standard</p>
	<p>either by a QP or CP.</p>		<p>Hazard Survey and prepare survey Report at existing buildings or structures.</p> <ul style="list-style-type: none"> The FP &PP shall be developed by either CP or QP. 	
<p>Preferred Order of Control Measures or Hierarchy of Controls for Fall hazards</p>	<ul style="list-style-type: none"> Elimination Prevention Engineering Controls (design change or using different techniques or equipment (i.e. Work Platforms)) Administrative Controls Personal Protective Systems and Equipment. 	<ul style="list-style-type: none"> Not addressed 	<ul style="list-style-type: none"> Elimination Prevention Work Platforms Personal Protective Systems and Equipment Administrative Controls 	<ul style="list-style-type: none"> Not addressed
<p>Guardrails</p> <p>Constructed from wood, structural steel, pipe or steel cable</p>	<ul style="list-style-type: none"> Consists of top rail, midrail, posts, and toeboard (toeboard as applicable). Top rail shall be <u>42 +/- 3 inches</u> high and withstands a force of <u>200 lbs.</u> 	<ul style="list-style-type: none"> Consists of top-rail, mid-rails, posts, and toeboards Top edge of railing shall be <u>42 + 3/- inches</u> high and withstands a force of <u>200 lbs.</u> Mid rails half way between top 	<ul style="list-style-type: none"> Consists of top-rail, midrail, posts, and toeboard. Top rail shall have a vertical height of <u>42 +/- 3 inches</u> and withstands a force of <u>200 lbs.</u> Mid rails half way between top rail and staging, 	<ul style="list-style-type: none"> Consists of top-rail and midrail, posts, and toeboard Top edge of railing shall be <u>42 +/- 3 inches</u> high and withstands a force of <u>200 lbs.</u> Mid rails half

DEPARTMENT OF THE NAVY FALL PROTECTION GUIDE FOR ASHORE FACILITIES

August, 2013

Requirements	<p>Navy FP Chapter 13 of OPNAVINST 5100.23 Series and Fall Protection Guide for Ashore Facilities</p> <p>Marine Corps Chapter 18, of NAVMC DIR 5100.8, Fall Protection Program</p>	<p>29 CFR 1910</p> <p>General Industry Standard OSHA Notices of Proposed Rulemaking Requirements of March 2010</p> <p>Subpart D and I</p>	<p>USACE EM385-1-1 (2013)</p> <p>Section 21 Fall Protection</p>	<p>29 CFR 1926</p> <p>Construction Standard</p>
	<ul style="list-style-type: none"> • Mid rails half way between top-rail and walking/working level and shall withstand a force of <u>150 lbs.</u> • Posts spaced no more than <u>8 feet</u> apart. • • Toe-boards shall be <u>3 ½ inches</u> high and shall withstand a force of <u>50 lbs.</u> • <u>For existing Parapet walls with height less than 42 inches, may be used as FP system if the vertical height is a min of 30 inches with a width of 18 inches at top of the wall for a total width of 48 inches.</u> 	<p>railing and walking/working level and shall withstand a force of <u>150 lbs.</u></p> <ul style="list-style-type: none"> • Posts spaced no more than <u>8 feet</u> apart. • Toe-boards shall be <u>3 ½ inches</u> high and shall withstand a force of <u>50 lbs.</u> 	<p>working platform, or runway and shall withstand a force of <u>150 lbs.</u></p> <ul style="list-style-type: none"> • Posts spaced no more than <u>8 feet</u> apart. • Toe-boards shall be <u>3 ½ inches</u> high and shall withstand a force of <u>50 lbs.</u> • <u>For existing Parapet wall with height less than 42 inches, may be used as FP system if the vertical height is a min of 30 inches with a width of 18 inches at top of the wall for a total width of 48 inches.</u> 	<p>way between top railing and walking/working level.</p> <ul style="list-style-type: none"> • Posts spaced no more than <u>8 feet</u> apart. • Toe-boards shall be <u>3 ½ inches</u> high and shall withstand a force of <u>50 lbs.</u>
<p>Work Platforms</p>	<ul style="list-style-type: none"> • When working <u>≥ 4 feet</u> above the ground, the 	<p>Railing is required when working <u>≥ 4 feet</u> above the ground</p>	<ul style="list-style-type: none"> • FP required above <u>6 feet for</u> 	<ul style="list-style-type: none"> • When working <u>≥ 6 feet</u> above solid surface,

DEPARTMENT OF THE NAVY FALL PROTECTION GUIDE FOR ASHORE FACILITIES

August, 2013

Requirements	<p>Navy FP Chapter 13 of OPNAVINST 5100.23 Series and Fall Protection Guide for Ashore Facilities</p> <p>Marine Corps Chapter 18, of NAVMC DIR 5100.8, Fall Protection Program</p>	<p>29 CFR 1910</p> <p>General Industry Standard OSHA Notices of Proposed Rulemaking Requirements of March 2010</p> <p>Subpart D and I</p>	<p>USACE EM385-1-1 (2013)</p> <p>Section 21 Fall Protection</p>	<p>29 CFR 1926</p> <p>Construction Standard</p>
	<p>platform must be equipped with a standard guardrail or other fall protection systems.</p> <ul style="list-style-type: none"> All Types of Suspended scaffolds require railing and single anchor vertical lifeline system. <p>Scissor lifts shall be equipped with standard guardrails. In addition scissor lift shall be equipped with anchorages meeting ANSI Z359, Fall Protection Code/Standards. A restraint system shall be used to prohibit workers from climbing out of, or being ejected from, the platform. It is highly recommended to use adjustable energy absorbing lanyards All suspended scaffolds require railing and single anchor vertical</p>	<p>level.</p> <p>All work platforms and Scissor lifts comply with 1926 Subpart L</p>	<p><u>contractors.</u></p> <ul style="list-style-type: none"> For USACE Operated Facilities FP is required above 4 ft. Scaffolds shall be equipped w/guardrail or other FP system. For workers erecting and dismantling scaffolds, if it is not feasible to provide FP, an evaluation shall be conducted by the competent person for fall protection detailing rationale why FP is not feasible and shall be submitted to GDA for review and acceptance as part of AHA. Suspended scaffolds require railing and single anchor vertical lifeline. Self Propelled Elevating Work Platforms (Scissor lifts) shall be equipped with standard guardrails. And anchorages 	<p>platforms must be equipped with a standard guard or other fall protection system.</p> <ul style="list-style-type: none"> Suspended scaffolds require railing and vertical lifeline. Scissor lifts-require railing.

DEPARTMENT OF THE NAVY FALL PROTECTION GUIDE FOR ASHORE FACILITIES

August, 2013

Requirements	<p>Navy FP Chapter 13 of OPNAVINST 5100.23 Series and Fall Protection Guide for Ashore Facilities</p> <p>Marine Corps Chapter 18, of NAVMC DIR 5100.8, Fall Protection Program</p>	<p>29 CFR 1910</p> <p>General Industry Standard OSHA Notices of Proposed Rulemaking Requirements of March 2010</p> <p>Subpart D and I</p>	<p>USACE EM385-1-1 (2013)</p> <p>Section 21 Fall Protection</p>	<p>29 CFR 1926</p> <p>Construction Standard</p>
	<p>lifeline system.</p>		<p>meeting Z359. A restraint system with a lanyard sufficiently short shall be used. Lanyards with built in EA are acceptable. SRL are also acceptable if permitted by the manufacturer in writing and used in accordance with strict compliance w/manufacturer instructions and as determined in writing by the QP. For FP All suspended scaffolds require railing and vertical lifeline.</p>	
<p>Covers</p>	<ul style="list-style-type: none"> • Install on any hole 2 inches or more in its least dimension in walking working surfaces. • Shall be capable of supporting, without failure, at least twice the weight of employees, equipment, and materials that may be imposed on the 	<ul style="list-style-type: none"> • Covers shall be capable of supporting without failure the maximum intended load of employees, equipment and material combined or 250 lbs whichever is greater. • Provide hinged floor opening cover of standard strength and 	<ul style="list-style-type: none"> • Install covers on any hole, 2 inches or more in its least dimension. • Shall be capable of supporting without failure, at least twice the weight of worker, equipment and material combined. • Shall be secured and color coded when installed. 	<ul style="list-style-type: none"> • Install on any hole, 2 inches or more in its least dimension in walking working surfaces. • Shall be capable of supporting, without failure, at least twice the weight of employees, equipment, and materials that may be imposed on the cover at one time. No stipulation for

DEPARTMENT OF THE NAVY FALL PROTECTION GUIDE FOR ASHORE FACILITIES

August, 2013

Requirements	<p>Navy FP Chapter 13 of OPNAVINST 5100.23 Series and Fall Protection Guide for Ashore Facilities</p> <p>Marine Corps Chapter 18, of NAVMC DIR 5100.8, Fall Protection Program</p>	<p>29 CFR 1910</p> <p>General Industry Standard OSHA Notices of Proposed Rulemaking Requirements of March 2010</p> <p>Subpart D and I</p>	<p>USACE EM385-1-1 (2013)</p> <p>Section 21 Fall Protection</p>	<p>29 CFR 1926</p> <p>Construction Standard</p>
	<p>cover at one time.</p> <ul style="list-style-type: none"> ○ When covers are removed, a guard, attendant or other system shall be provided to protect floor holes or openings. 	<p>construction equipped with guard or permanently attached.</p>		<p>removal.</p>
<p>Safety Net Systems</p>	<ul style="list-style-type: none"> • Shall be installed as close as possible under the walking working surface with unprotected side or edge but not lower than 25 feet. • Maximum size of mesh opening shall not exceed 36 square inches and no longer than 6 inches on any side. • Minimum breaking strength of outer rope or webbing shall be 5,000 lbs. • Shall be tested 	<ul style="list-style-type: none"> • Presently not addressed in 29 CFR 1910. • Addressed only in OSHA 29 CFR 1910 Notices of Proposed Rulemaking of 1990. • Similar to 29 CFR 1926, Subpart M requirements 	<ul style="list-style-type: none"> • Shall be installed as close as practicable under the walking, working surfaces, but not lower than 25 feet. • Maximum size of mesh opening shall not exceed 36 square inches and no longer than 6 inches on any side. • Minimum breaking strength of outer rope or webbing shall be 5,000 lbs. • Shall be tested immediately after installation with a 400 lbs san bag dropped from a height at least 42 inches above the walking and working surfaces. • Inspection: 	<ul style="list-style-type: none"> • Shall be installed as close as practicable under the walking, working surfaces, but not lower than 30 feet. • Minimum braking strength of outer rope or webbing shall be 5,000 lbs. • Maximum size of mesh opening shall not exceed 36 square inches and no longer than 6 inches on any side. • Shall be tested immediately after installation with a 400 lbs san bag dropped from a height at least 42

DEPARTMENT OF THE NAVY FALL PROTECTION GUIDE FOR ASHORE FACILITIES

August, 2013

Requirements	<p>Navy FP Chapter 13 of OPNAVINST 5100.23 Series and Fall Protection Guide for Ashore Facilities</p> <p>Marine Corps Chapter 18, of NAVMC DIR 5100.8, Fall Protection Program</p>	<p>29 CFR 1910</p> <p>General Industry Standard OSHA Notices of Proposed Rulemaking Requirements of March 2010</p> <p>Subpart D and I</p>	<p>USACE EM385-1-1 (2013)</p> <p>Section 21 Fall Protection</p>	<p>29 CFR 1926</p> <p>Construction Standard</p>
	<p>immediately after installation with a 400 lbs san bag dropped from the same elevation a worker might fall.</p> <ul style="list-style-type: none"> Specifies limits for safety net extension below the unprotected side or edge. 		<p>immediately after installation, weekly thereafter and following any repair or alteration. Inspection shall be documented.</p> <ul style="list-style-type: none"> Specifies limits for safety net extension below the unprotected side or edge 	<p>inches above the walking, working surfaces.</p> <ul style="list-style-type: none"> Specific limits for safety net extension below the unprotected side or edge.
<p>Personal Fall Arrest System (PFAS) Requirements</p>	<ul style="list-style-type: none"> Maximum free fall distance of 6 feet. Maximum arresting force of 1,800 lbs. Shall stop the fall with a deceleration distance of less than 42 inches. Prevent a person from contacting lower level or object. Body belts are not authorized. 	<p>For walking/working surfaces, PFAS requirements are addressed in OSHA 29 CFR 1910 Notices of Proposed Rulemaking of 1990.</p> <ul style="list-style-type: none"> Maximum free fall distance of 6 feet. Maximum arresting force of 1,800 lbs. Shall stop the fall with a deceleration distance of less than 42 inches. Prevent a person from contacting lower level or object. 	<ul style="list-style-type: none"> Maximum free fall distance of 6 feet. Maximum arresting force of 1,800 lbs. Shall stop the fall with a deceleration distance of less than 42 inches. Prevent a person from contacting lower level or object. Body belts are not authorized. 	<ul style="list-style-type: none"> Maximum free fall distance of 6 feet. Maximum arresting force of 1,800 lbs. Shall stop the fall with a deceleration distance of less than 42 inches. Prevent a person from contacting lower level or object. Body belts are not authorized

DEPARTMENT OF THE NAVY FALL PROTECTION GUIDE FOR ASHORE FACILITIES

August, 2013

Requirements	<p>Navy FP Chapter 13 of OPNAVINST 5100.23 Series and Fall Protection Guide for Ashore Facilities</p> <p>Marine Corps Chapter 18, of NAVMC DIR 5100.8, Fall Protection Program</p>	<p>29 CFR 1910</p> <p>General Industry Standard OSHA Notices of Proposed Rulemaking Requirements of March 2010</p> <p>Subpart D and I</p>	<p>USACE EM385-1-1 (2013)</p> <p>Section 21 Fall Protection</p>	<p>29 CFR 1926</p> <p>Construction Standard</p>
		<ul style="list-style-type: none"> Body belts are prohibited. 		
<p>Fall Protection Equipment Selection Criteria</p>	<ul style="list-style-type: none"> Navy activities should use only manufacturer certified equipment and meet ANSI Z359. FP Code/ Standards. Any equipment meeting ANSI A10.14 shall not be used. Only the qualified person for fall protection can make the determination of increasing the free fall distance more than 6 feet. Frontal D-ring attachment point located at the sternum can be used for fall arrest provided the free fall distance is less than 2 feet and maximum arrest force does not exceed 900 lbs. 	<ul style="list-style-type: none"> Employers should obtain comprehensive instructions from the suppliers. 	<ul style="list-style-type: none"> Selection of equipment shall be based on type of work; work environment, weight, size and shape of the worker, type and position/location of anchorage and length of lanyard. Use only equipment meeting ANSI Z359.FP Code/Standards Standard. Any equipment meeting ANSI A10.14 shall not be used. Frontal D-ring attachment point located at the sternum can be used for fall arrest provided the free fall distance is less than 2 feet and maximum arrest force does not exceed 900 lbs. Only the qualified person for fall protection can make the determination of increasing the free fall distance more than 6 feet. 	<ul style="list-style-type: none"> The type of fall arrest system selected should match the particular work situation and any free fall distance should be kept to a minimum. Consideration should be given to a particular work environment.

DEPARTMENT OF THE NAVY FALL PROTECTION GUIDE FOR ASHORE FACILITIES

August, 2013

<p>Requirements</p>	<p>Navy FP Chapter 13 of OPNAVINST 5100.23 Series and Fall Protection Guide for Ashore Facilities</p> <p>Marine Corps Chapter 18, of NAVMC DIR 5100.8, Fall Protection Program</p>	<p>29 CFR 1910</p> <p>General Industry Standard OSHA Notices of Proposed Rulemaking Requirements of March 2010</p> <p>Subpart D and I</p>	<p>USACE EM385-1-1 (2013)</p> <p>Section 21 Fall Protection</p>	<p>29 CFR 1926</p> <p>Construction Standard</p>
<p>Definition of Qualified Person</p>	<p><u>Qualified Person for Fall Protection:</u> A person with a recognized <u>engineering degree</u> or professional certificate and with extensive knowledge, training, and <u>experience in fall protection and rescue field</u>, who is capable of performing design, analysis, and evaluation of <u>fall protection rescue systems and equipment.</u></p>	<p><u>Qualified Person</u> means one with a <u>recognized degree</u> or professional certificate or extensive knowledge and experience in the subject field who is capable of design, analysis, evaluation and specifications in the subject work, project, or product.</p>	<p><u>Qualified Person for Fall Protection (New - see Appendix Q):</u> A person with a recognized degree or professional certificate and with extensive knowledge, training, and experience in the <u>fall protection and rescue field</u> who is capable of designing, analyzing, evaluating and specifying <u>fall protection and rescue systems.</u></p>	<p><u>Qualified:</u> means one who, by possession of a recognized degree, certificate, or professional standing, or who by extensive knowledge, training, and experience, has successfully demonstrated his ability to solve or resolve problems relating to the subject matter, the work, or the project.</p>
<p>Definition of Competent Person</p>	<p><u>Competent Person for Fall Protection:</u> A person designated by the Command to be responsible for the immediate supervision, implementation and monitoring of the fall protection program, who through training knowledge and expertise is capable of identifying, evaluating and addressing existing and potential fall hazards and in the</p>	<p><u>Competent Person:</u> Means a person who is capable of identifying hazardous or dangerous conditions in any personal fall arrest system or any component thereof, as well as in their application and use with related equipment.</p>	<p><u>Competent Person for Fall Protection (New – See Appendix Q):</u> A person designated in writing in the AHA by the employer to be responsible for the immediate supervision, implementation and monitoring of the fall protection program, who through training, knowledge and experience in fall protection and rescue systems and equipment, is capable of identifying, evaluating and addressing existing and</p>	<p><u>Competent Person:</u> Means one who is capable of identifying existing and predictable hazards in the surroundings or working conditions which are unsanitary, hazardous, or dangerous to employees, and who has authorization to take prompt corrective measures to eliminate them.</p>

DEPARTMENT OF THE NAVY FALL PROTECTION GUIDE FOR ASHORE FACILITIES

August, 2013

Requirements	<p>Navy FP Chapter 13 of OPNAVINST 5100.23 Series and Fall Protection Guide for Ashore Facilities</p> <p>Marine Corps Chapter 18, of NAVMC DIR 5100.8, Fall Protection Program</p>	<p>29 CFR 1910</p> <p>General Industry Standard OSHA Notices of Proposed Rulemaking Requirements of March 2010</p> <p>Subpart D and I</p>	<p>USACE EM385-1-1 (2013)</p> <p>Section 21 Fall Protection</p>	<p>29 CFR 1926</p> <p>Construction Standard</p>
	<p>application and use of personal fall arrest and rescue system or any component thereof, AND who has the authority to take prompt corrective measures to eliminate or control the hazards of falling.</p>		<p>potential fall hazards and, who has the authority to take prompt corrective measures with regard to such hazards.</p>	
<p>Fall Arrest Anchorages</p>	<ul style="list-style-type: none"> Capable of supporting a minimum of 5,000 lbs attached; or shall be designed, installed and used under the supervision of a qualified person and shall maintain a safety factor of at least two. 	<ul style="list-style-type: none"> In the PRM, references the anchorage strength for personal; FP system as 5,000 pounds 	<ul style="list-style-type: none"> Capable of supporting at least 5,000 lbs per worker attached or designed by a qualified person for fall protection for twice the maximum arrest force on the body. <p>All HLL anchorages shall be designed by a registered PE qualified in designing HLL systems.</p>	<ul style="list-style-type: none"> Anchorages shall be capable of supporting at least 5,000 lbs per employee attached, or shall be designed, installed and used as part of a complete fall arrest system which maintains a safety factor of least 2 and under the supervision of qualified person.
	<ul style="list-style-type: none"> The Gates of Snaphooks and carabiners shall withstand a force of 3,600 pounds in all 	<ul style="list-style-type: none"> The gates of snaphooks and carabiners shall withstand a side loading of 350 pounds and face loading of 220 	<ul style="list-style-type: none"> The Gates of Snaphooks and carabiners shall withstand a force of 3,600 pounds in all directions 	<ul style="list-style-type: none"> The gates of snaphooks and carabiners shall withstand a side loading of 220 pounds and face loading of 220

DEPARTMENT OF THE NAVY FALL PROTECTION GUIDE FOR ASHORE FACILITIES

August, 2013

Requirements	<p>Navy FP Chapter 13 of OPNAVINST 5100.23 Series and Fall Protection Guide for Ashore Facilities</p> <p>Marine Corps Chapter 18, of NAVMC DIR 5100.8, Fall Protection Program</p>	<p>29 CFR 1910</p> <p>General Industry Standard OSHA Notices of Proposed Rulemaking Requirements of March 2010</p> <p>Subpart D and I</p>	<p>USACE EM385-1-1 (2013)</p> <p>Section 21 Fall Protection</p>	<p>29 CFR 1926</p> <p>Construction Standard</p>
	<p>directions</p> <ul style="list-style-type: none"> • Snaphooks and Carabiners manufactured per ANSI Z359.1 (1992-R1999) shall not be used 	<p>pounds</p>	<ul style="list-style-type: none"> • Snaphooks and Carabiners manufactured per ANSI Z359.1 (1992-R1999) shall not be used 	<p>pounds</p>
<p>Energy Absorbing Single and Y Lanyards</p>	<ul style="list-style-type: none"> • The 6 ft FF Energy Absorbing (EA) Lanyards shall be used when the tie-off point is above the dorsal D ring. The average arrest force on the body shall not exceed 900 lbs. • The 12 ft FF EA Lanyard shall be used when the tie-off point is below the dorsal D ring creating a FF distance of more than 6 feet. The average arrest force on the body shall not exceed 1,350 lbs. • The 12 ft FF EA lanyard may also be used 	<ul style="list-style-type: none"> • SRLs that automatically limit free fall distance to 2 feet or less, must withstand a min tensile load of 3,000 pounds • SRLs that do not limit the FF to 2 feet or less must be capable of sustaining a min tensile load of 5,000 pounds, 	<ul style="list-style-type: none"> • The 6 ft FF Energy Absorbing (EA) Lanyards shall be used when the tie-off point is above the dorsal D ring. The average arrest force on the body shall not exceed 900 lbs. • The 12 ft FF EA Lanyard shall be used when the tie-off point is below the dorsal D ring creating a FF distance of more than 6 feet. The average arrest force on the body shall not exceed 1,350 lbs. • The 12 ft FF EA lanyard may also be used when the free fall distance is less than 6 ft. • The length of all EA lanyards used in FA shall not exceed 6 	<ul style="list-style-type: none"> • SRLs that automatically limit free fall distance to 2 feet or less, must withstand a min tensile load of 3,000 pounds • No reference to SRLs that do not limit the FF to less

DEPARTMENT OF THE NAVY FALL PROTECTION GUIDE FOR ASHORE FACILITIES

August, 2013

Requirements	<p>Navy FP Chapter 13 of OPNAVINST 5100.23 Series and Fall Protection Guide for Ashore Facilities</p> <p>Marine Corps Chapter 18, of NAVMC DIR 5100.8, Fall Protection Program</p>	<p>29 CFR 1910</p> <p>General Industry Standard OSHA Notices of Proposed Rulemaking Requirements of March 2010</p> <p>Subpart D and I</p>	<p>USACE EM385-1-1 (2013)</p> <p>Section 21 Fall Protection</p>	<p>29 CFR 1926</p> <p>Construction Standard</p>
	<p>when the free fall distance is less than 6 ft.</p> <ul style="list-style-type: none"> • The length of all EA lanyards used in FA shall not exceed 6 feet. • The 6 ft and 12 ft EA Lanyards shall meet the requirements of ANSI Z359.13 Standard. 		<p>feet.</p> <ul style="list-style-type: none"> • The 6 ft and 12 ft EA Lanyards shall meet the requirements of ANSI Z359.13 Standard. 	
<p>Training</p>	<ul style="list-style-type: none"> • Workers exposed to fall hazards from heights and using FP equipment shall be trained by a competent person for fall protection who is qualified in delivering FP training. • Retraining shall also be provided as necessary. • Refresher training will be provided at an interval determined by the activity. • Training of all 	<ul style="list-style-type: none"> • States that employer must provide training to each employee who uses personal FP equipment. • Retraining is required. 	<ul style="list-style-type: none"> • Workers exposed to fall hazards from heights and using FP equipment shall be trained by competent person for fall protection who is qualified in delivering FP training. • Retraining shall also be provided as necessary. • Employer shall verify worker training by a written certification record including name of worker, date of training and signatures of trainer and trainee. • Training of all personnel involved 	<ul style="list-style-type: none"> • States that FP training is required.

DEPARTMENT OF THE NAVY FALL PROTECTION GUIDE FOR ASHORE FACILITIES

August, 2013

Requirements	<p>Navy FP Chapter 13 of OPNAVINST 5100.23 Series and Fall Protection Guide for Ashore Facilities</p> <p>Marine Corps Chapter 18, of NAVMC DIR 5100.8, Fall Protection Program</p>	<p>29 CFR 1910</p> <p>General Industry Standard OSHA Notices of Proposed Rulemaking Requirements of March 2010</p> <p>Subpart D and I</p>	<p>USACE EM385-1-1 (2013)</p> <p>Section 21 Fall Protection</p>	<p>29 CFR 1926</p> <p>Construction Standard</p>
	<p>personnel involved in the FP program including associated trainers shall be in accordance w/ANSI Z359.2.</p>		<p>in the FP program including associated trainers shall be in accordance w/ANSI Z359.2</p>	
<p>Horizontal Lifeline</p>	<ul style="list-style-type: none"> Designed prior to use by a registered professional engineer with experience in designing horizontal lifeline systems and as part of a complete fall arrest system that maintains a safety factor of at least <u>two</u>. 	<ul style="list-style-type: none"> Shall be designed and installed as part of a complete fall arrest system which maintains a safety factor of at least <u>2</u> under the supervision of a qualified person. 	<ul style="list-style-type: none"> HLL shall be installed and used under the supervision of qualified person for fall protection only, as part of a complete fall arrest system that maintains a safety factor of at least <u>two</u>. 	<ul style="list-style-type: none"> Designed, installed, and used under the supervision of a qualified person and used as part of a complete personal fall arrest system that maintains a safety factor of at least <u>two</u>.
<p>Positioning System Requirement</p>	<ul style="list-style-type: none"> Limit the free fall distance to <u>2 feet</u>. Secured to an anchorage capable of supporting <u>twice</u> the potential impact loading or <u>3,000 lbs</u> whichever is greater. In addition to positioning system, 	<ul style="list-style-type: none"> Not addressed in 29 CFR1910. Addressed only in the OSHA Proposed Rulemaking of 1990. The Requirements are similar to 29 CFR 1926, Subpart M. Anchorage for personal FP system must be capable of supporting at least 	<ul style="list-style-type: none"> Be rigged such that a worker cannot free fall more than <u>2 feet</u>. Secured to an anchorage capable of supporting at least <u>twice</u> the potential impact load of a worker's fall or <u>3,000 lbs</u> whichever is greater. In addition to positioning system, requires the use of 	<ul style="list-style-type: none"> Shall be secured to an anchorage capable of supporting at least <u>twice</u> the potential impact load of an employee's fall or <u>3,000 lbs</u> whichever is greater. Shall be rigged such that an employee cannot free fall more than <u>2 feet</u>.

DEPARTMENT OF THE NAVY FALL PROTECTION GUIDE FOR ASHORE FACILITIES

August, 2013

Requirements	<p>Navy FP Chapter 13 of OPNAVINST 5100.23 Series and Fall Protection Guide for Ashore Facilities</p> <p>Marine Corps Chapter 18, of NAVMC DIR 5100.8, Fall Protection Program</p>	<p>29 CFR 1910</p> <p>General Industry Standard OSHA Notices of Proposed Rulemaking Requirements of March 2010</p> <p>Subpart D and I</p>	<p>USACE EM385-1-1 (2013)</p> <p>Section 21 Fall Protection</p>	<p>29 CFR 1926</p> <p>Construction Standard</p>
	<p>requires the use of a separate system that provides back-up.</p>	<p>5,000 pounds</p>	<p>a separate system that provides back-up.</p>	
<p>Restraint Anchorages</p>	<ul style="list-style-type: none"> • Anchorage strength requirement shall be 3,000 lbs or designed by a qualified person for FP for two times the foreseeable force. • Restraint system shall be used only on sloped surfaces equal or less than 18.4 degrees (4:12 slope) 	<ul style="list-style-type: none"> • Anchorage strength is not specified in 29 CFR 1910 Standard • No reference to Anchorage strength 	<ul style="list-style-type: none"> • Anchorage strength requirement shall be 3,000 lbs or designed by a qualified person for FP for two times the foreseeable force. • Restraint system shall be used only on sloped surfaces equal or less than 18.4 degrees (4:12 slope). 	<ul style="list-style-type: none"> • Anchorages shall have the capacity to withstand at least 3,000 lbs of force or twice the maximum expected force. (*)
<p>Inspection, storage, care, and maintenance of FP equipment</p>	<ul style="list-style-type: none"> • Before each use, the user shall carefully inspect the FP equipment. The competent person must inspect the FP equipment at least annually with documentation. 	<ul style="list-style-type: none"> • FP equipment shall be inspected prior to each use; employer should obtain comprehensive instructions from the supplier method of inspection, use cleaning and storage. 	<ul style="list-style-type: none"> • Equipment shall be inspected by the end-user prior to each use. • A Competent person for FP shall inspect the equipment at least once semi-annually and whenever equipment is subjected to a fall or 	<ul style="list-style-type: none"> • Personal fall arrest system shall be inspected prior to each use for wear, damage and other deteriorations.

DEPARTMENT OF THE NAVY FALL PROTECTION GUIDE FOR ASHORE FACILITIES

August, 2013

Requirements	<p>Navy FP Chapter 13 of OPNAVINST 5100.23 Series and Fall Protection Guide for Ashore Facilities</p> <p>Marine Corps Chapter 18, of NAVMC DIR 5100.8, Fall Protection Program</p>	<p>29 CFR 1910</p> <p>General Industry Standard OSHA Notices of Proposed Rulemaking Requirements of March 2010</p> <p>Subpart D and I</p>	<p>USACE EM385-1-1 (2013)</p> <p>Section 21 Fall Protection</p>	<p>29 CFR 1926</p> <p>Construction Standard</p>
			<p>impacted.</p> <ul style="list-style-type: none"> Competent person's inspection shall be documented. 	
<p>Climbing Ladder Fall Arrest System (Requirements (Previously called Ladder Climbing Device (LCD))</p>	<ul style="list-style-type: none"> Installed on fixed ladders more than 20 feet in length. Anchorage strength 3000 lbs. Free fall distance shall not exceed 2 feet. Length of connector between D-ring and LCD shall be 9-12 inches 100% transition at top of ladder. Do not install LCD on ladders having $\frac{3}{4}$ inch rungs unless they are designed to withstand the fall forces. 	<ul style="list-style-type: none"> Installed on fixed ladders more than 20 feet in length. LCD shall meet the design requirements of the ladders which they serve. 	<ul style="list-style-type: none"> Installed on fixed ladders more than 20 feet in length. Anchorage strength 3000 lbs Free fall distance shall not exceed 2 feet. Length of connector between D-ring and LCD shall be 9 inches. 100% transition at top of ladder. Do not install LCD on ladders having $\frac{3}{4}$ inch rungs unless they are designed to withstand fall forces. 	<ul style="list-style-type: none"> Installed on fixed ladders more than 24 feet in length. Capable of withstanding a drop test of 500 lbs. Free fall distance shall not exceed 2 feet. Length of connector between D-ring and LCD shall be 9 inches.
<p>Rescue procedures</p>	<ul style="list-style-type: none"> When using fall arrest equipment, ensure mishap victim can self rescue or can 	<ul style="list-style-type: none"> The employer shall provide for prompt rescue of employees in the event of a fall or shall assure the 	<ul style="list-style-type: none"> Requirement to provide prompt rescue to all fallen workers. A rescue plan shall 	<ul style="list-style-type: none"> The employer shall provide for prompt rescue of employees in the event of a fall or shall ensure that

DEPARTMENT OF THE NAVY FALL PROTECTION GUIDE FOR ASHORE FACILITIES

August, 2013

Requirements	<p>Navy FP Chapter 13 of OPNAVINST 5100.23 Series and Fall Protection Guide for Ashore Facilities</p> <p>Marine Corps Chapter 18, of NAVMC DIR 5100.8, Fall Protection Program</p>	<p>29 CFR 1910</p> <p>General Industry Standard OSHA Notices of Proposed Rulemaking Requirements of March 2010</p> <p>Subpart D and I</p>	<p>USACE EM385-1-1 (2013)</p> <p>Section 21 Fall Protection</p>	<p>29 CFR 1926</p> <p>Construction Standard</p>
	<p>be rescued promptly should a fall occur.</p> <ul style="list-style-type: none"> • Personnel conducting rescue shall be trained. • Anchorages for self-rescue and assisted-rescue shall be identified and selected. • Anchorages selected for rescue shall be capable of withstanding static loads of 3,000 lbs or 5 times the applied loads as designed by qualified person for fall protection. • Buddy system (Safety person or spotter) is required. 	<p>self-rescue capability of employees.</p>	<p>be prepared and maintained.</p> <ul style="list-style-type: none"> • Personnel conducting rescue shall be trained. • Anchorages for self-rescue and assisted-rescue shall be identified and selected. • Anchorages selected for rescue shall be capable of withstanding static loads of 3,000 lbs or 5 times the applied loads as designed by qualified person for fall protection. • Buddy system (Safety person or spotter) is required. • If other methods of rescue are planned (Fire Department) it shall be indicated in the rescue plan. 	<p>employees can rescue themselves.</p>
<p>Warning Line system/Designated Area Method</p>	<ul style="list-style-type: none"> • Consists of wire rope or chains 34 -39 inches high. 	<ul style="list-style-type: none"> • The OSHA Notices of proposed Rulemaking uses the designated 	<ul style="list-style-type: none"> • Consists of wire rope or chains 34-39 inches high. • Tensile strength of 	<ul style="list-style-type: none"> • Consists of wire rope or chains 34-39 inches high.

DEPARTMENT OF THE NAVY FALL PROTECTION GUIDE FOR ASHORE FACILITIES

August, 2013

Requirements	<p>Navy FP Chapter 13 of OPNAVINST 5100.23 Series and Fall Protection Guide for Ashore Facilities</p> <p>Marine Corps Chapter 18, of NAVMC DIR 5100.8, Fall Protection Program</p>	<p>29 CFR 1910</p> <p>General Industry Standard OSHA Notices of Proposed Rulemaking Requirements of March 2010</p> <p>Subpart D and I</p>	<p>USACE EM385-1-1 (2013)</p> <p>Section 21 Fall Protection</p>	<p>29 CFR 1926</p> <p>Construction Standard</p>
	<ul style="list-style-type: none"> • Tensile strength of the line shall be min 500 lbs. • Stanchions shall be capable of withstanding a force of 16 lbs applied horizontally 30 inches from the walking working surfaces. • For roofing work, the line shall be erected 6 feet away from the edge. For other trades the line shall be 15 feet away from the edge. 	<p>area method which is similar to the requirements of warning line system.</p> <ul style="list-style-type: none"> • The line shall be established 6 feet away from the unprotected edge of a roof with a 100% transition from the point of access to the designated area. 	<p>the line shall be min 500 lbs.</p> <ul style="list-style-type: none"> • Stanchions shall be capable of withstanding a force of 16 lbs applied horizontally 30 inches from the walking working surfaces. • For roofing work, the line shall be erected 6 feet away from the edge. For other trades the line shall be 15 feet away from the edge. 	<ul style="list-style-type: none"> • Tensile strength of the line shall be min 500 lbs. • Stanchions shall be capable of withstanding a force of 16 lbs applied horizontally 30 inches from the walking working surfaces. • For roofing work, the line shall be erected 6 feet away from the edge. For other trades the line shall be 15 feet away from the edge.
<p>Controlled Access Zones</p>	<ul style="list-style-type: none"> • Not addressed in OPNAVINST 5100.23H, S&H Requirements Manual for Ashore Facilities, fall Protection program. The system is addressed in the FP Guide. The system shall not be used as a fall protection 	<ul style="list-style-type: none"> • Not addressed 	<ul style="list-style-type: none"> • Prohibited as a fall protection method. 	<ul style="list-style-type: none"> • Allowed by Subpart M.

DEPARTMENT OF THE NAVY FALL PROTECTION GUIDE FOR ASHORE FACILITIES

August, 2013

Requirements	<p>Navy FP Chapter 13 of OPNAVINST 5100.23 Series and Fall Protection Guide for Ashore Facilities</p> <p>Marine Corps Chapter 18, of NAVMC DIR 5100.8, Fall Protection Program</p>	<p>29 CFR 1910</p> <p>General Industry Standard OSHA Notices of Proposed Rulemaking Requirements of March 2010</p> <p>Subpart D and I</p>	<p>USACE EM385-1-1 (2013)</p> <p>Section 21 Fall Protection</p>	<p>29 CFR 1926</p> <p>Construction Standard</p>
	<p>method.</p>			
<p>Monitoring system</p>	<ul style="list-style-type: none"> • Monitoring system shall not be used by itself as a fall protection method. May be used in conjunction with other fall protection system. • Not addressed in OPNAVINST 5100.23G. Addressed in the FP Guide. 	<ul style="list-style-type: none"> • Not addressed. 	<ul style="list-style-type: none"> • Prohibited as a fall protection system. May be used with other fall protection method 	<ul style="list-style-type: none"> • Allowed per Subpart M.

(*) As per OSHA Interpretation Letter

August, 2013

APPENDIX B

TOTAL FALL DISTANCE

B.1 CALCULATING TOTAL FALL DISTANCE

The total fall distance is the sum of free fall distance and deceleration.

If a worker is connected to an anchorage using a six-foot energy-absorbing lanyard, and the anchorage is located 2.f feet above the worker's Dorsal D ring, what is the total fall distance?

- The maximum free-fall distance is:
6 ft (length of FA Lanyard – 2.5 ft = 3.5 feet)
- The deceleration distance is 4 feet

The Total Fall Distance is: 3.5 feet + 4 feet = 7.5 feet

B.2 CALCULATING THE CLEARANCE

- To determine what is the clearance requirement in Paragraph B.1 above, measured from the anchorage to the ground below. Assume the worker's "D" ring location is five feet from his toe at the instant of the worker's fall until he comes to a complete stop. A three-foot safety buffer is required between the bottom of the worker's shoe (After arresting a fall) and the ground below.

The D ring location after stopping the fall is:

7.5 feet – 5 feet (From d ring location to the working surface) = 2.5 feet

The minimum required clearance below the working surface is:

2.5 feet + 1 foot (harness stretch) + 5 feet (D-ring to toe of worker) + 3 feet safety buffer = 15 feet

B.3 Total Fall Distance Schematics

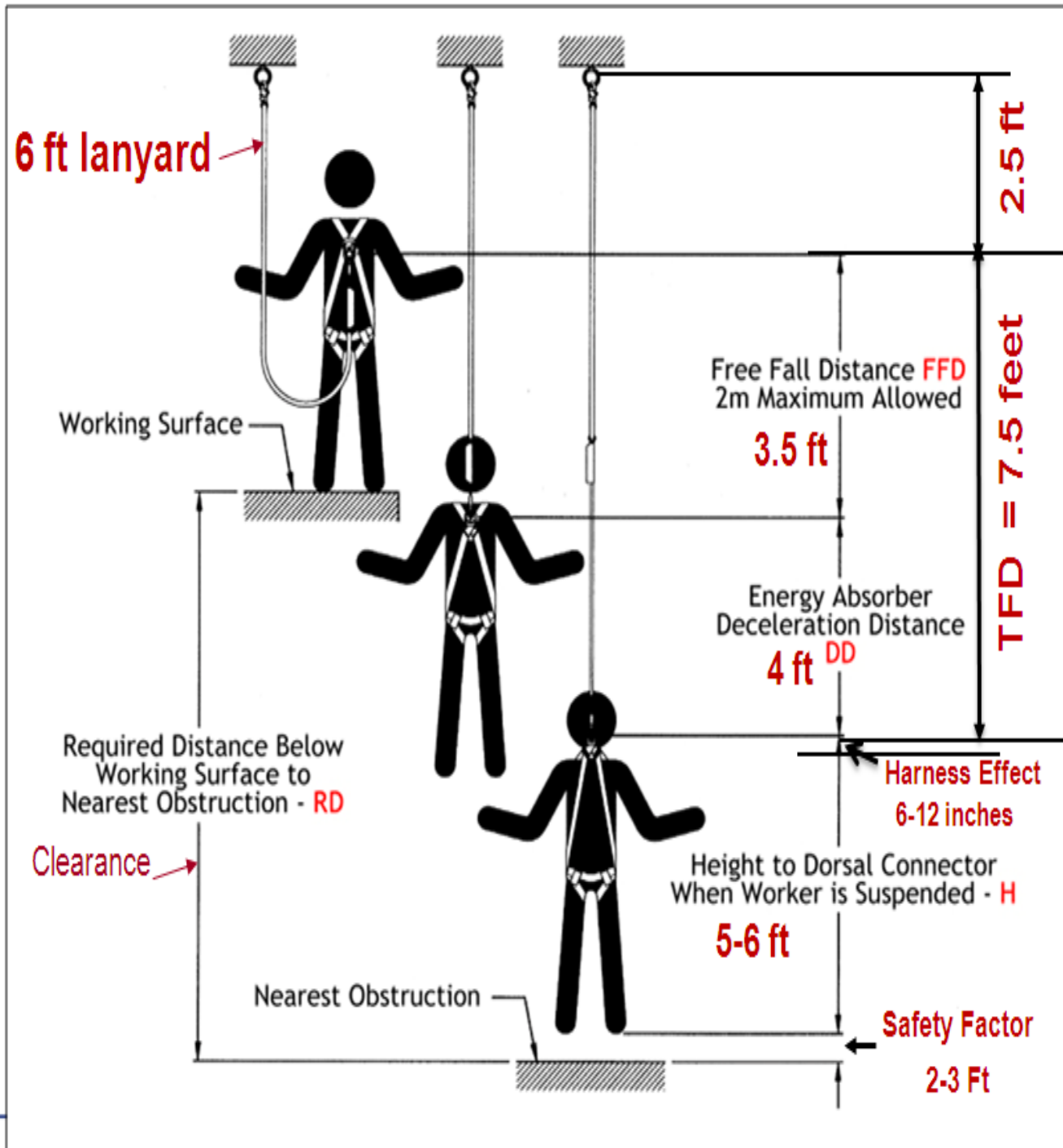

August, 2013

Total Fall Distance When using 6 Ft Free Fall Energy Absorbing Single Lanyard

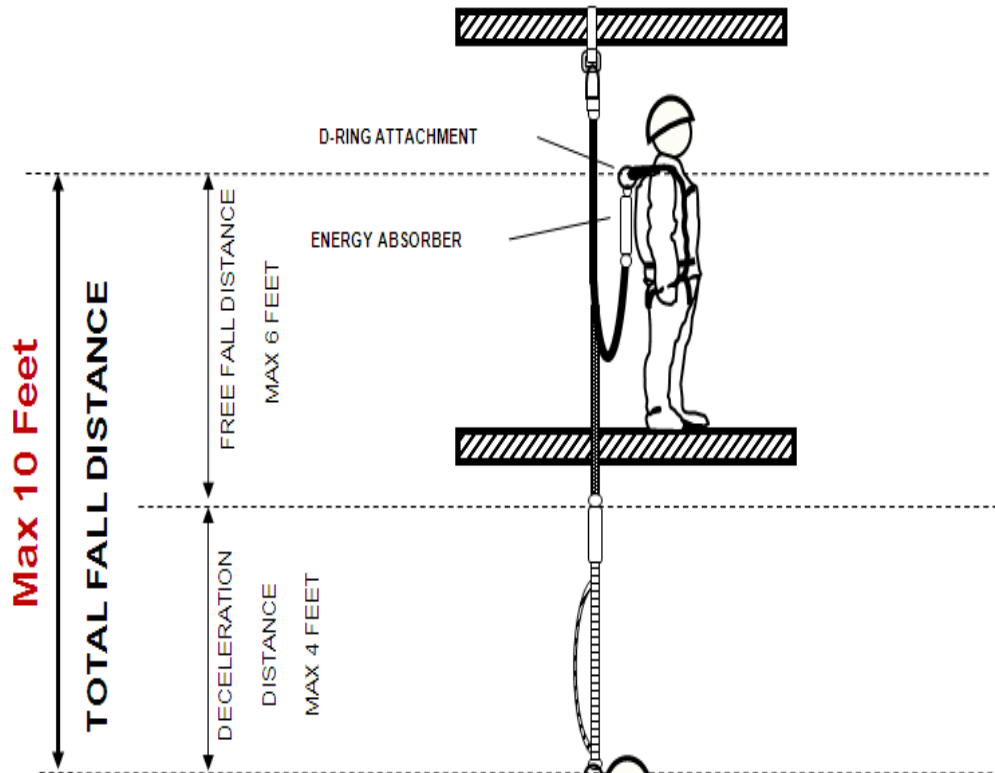

- **Maximum TFD of 10 feet occurs when the tie off point is at the D-ring level**
- **If the tie off point is 2 feet above the D-ring, the TFD = 8 feet**

August, 2013

Total Fall Distance when using 6 Ft Free Fall Energy Absorbing “Y” Lanyard

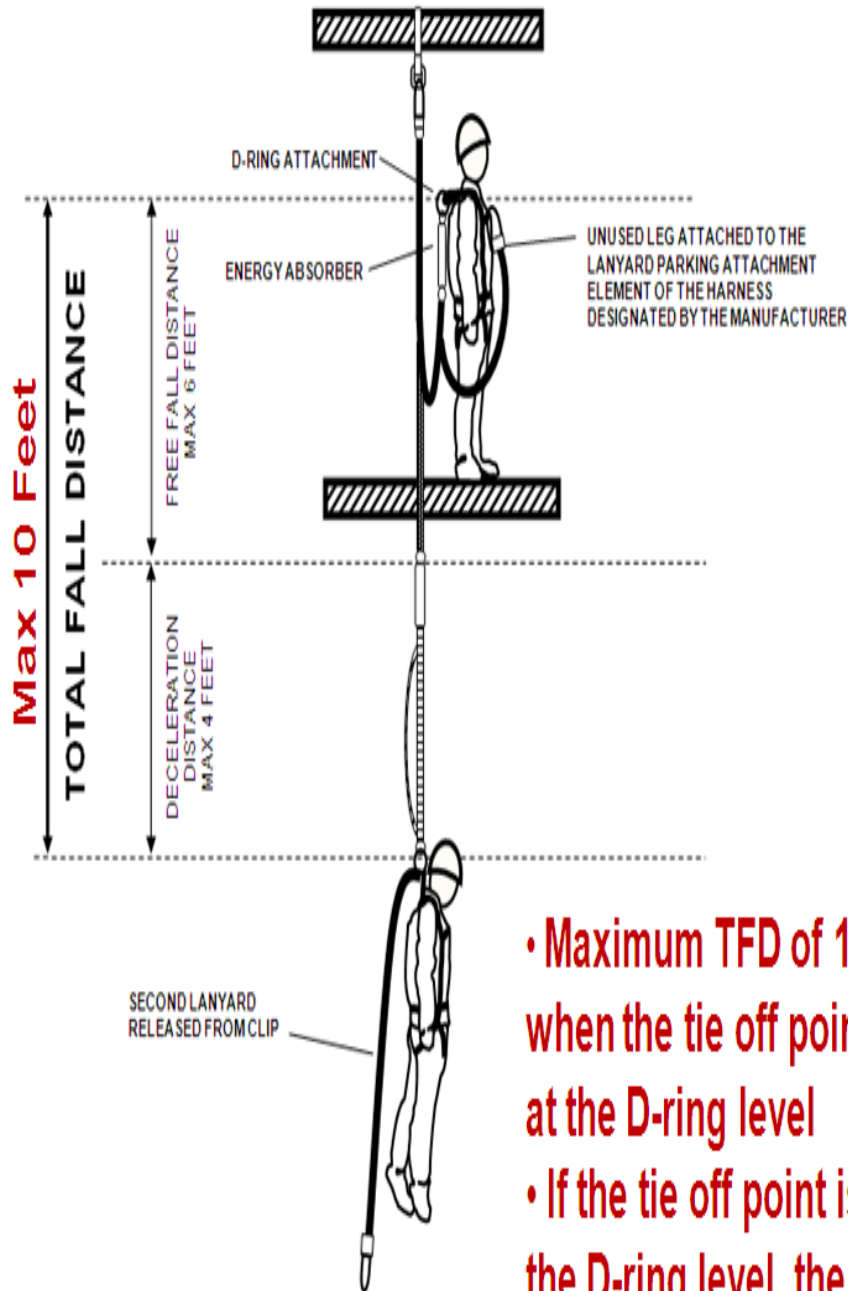

August, 2013

Total Fall Distance when using 12 ft Free Fall, Energy Absorbing Single or “Y” Lanyard (TFD for single or Y lanyard is identical)

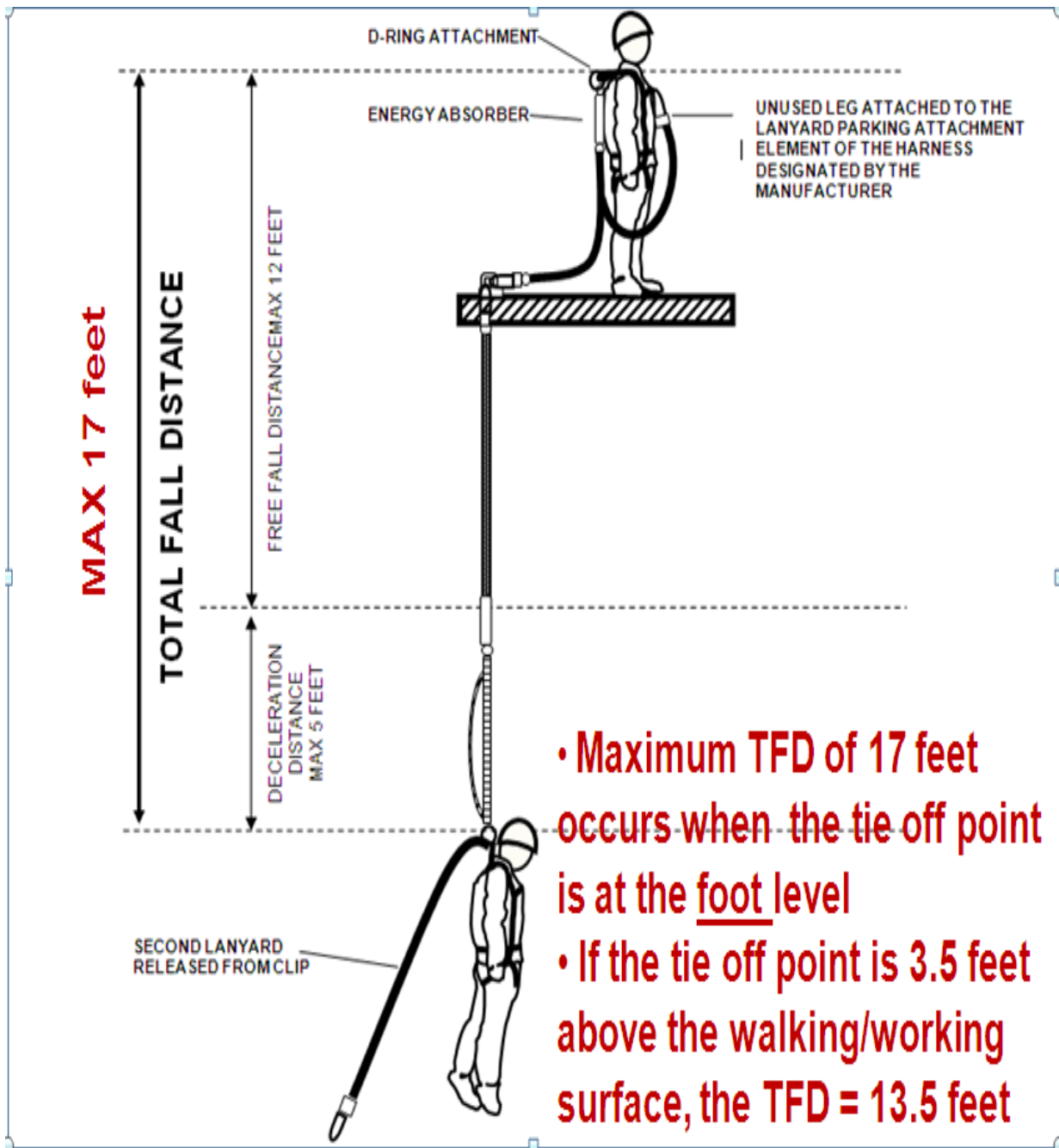

August, 2013

APPENDIX C

DISCUSSION, EXAMPLES/PROBLEMS AND SOLUTIONS TO FALL HAZARDS

The following examples/problems, questions, and solutions to fall hazards are included to help safety personnel, Resident Officers in Charge of Construction (ROICC), design engineers, contractors, and subcontractors to address fall hazard issues and concerns in the workplace, especially during the performance of work:

C.1 PRODUCT OR MATERIAL DELIVERY TO A CONSTRUCTION SITE

Question: Are vendors delivering products or materials to a construction site covered by 29 CFR 1926.500, Subpart M, where the products and material are delivered to a location on the construction site six feet or more above lower level?

Answer: Yes, they are required to comply with Subpart M. Vendors and others are considered engaged in construction activities when they deliver products or materials to a construction site that are used during construction work or when they are engaged in an activity that completes the construction work, such as final cleanup of buildings and structures. If the construction contractors picked up the products or materials at the vendor's outlet (store, warehouse, etc.) the vendor, depending upon the type of facility, may not be regulated by 29 CFR 1926.500, Subpart M.

C.2. DELIVERY AND PLACEMENT OF ROOFING MATERIALS

Question: What are the obligations of suppliers of roofing materials when they deliver roofing materials to a construction site and place the material on the roof?

Answer: Because the products will be used during construction activities, the suppliers will be required under Subpart M to protect their employees from falls of six feet or more to lower levels when possible. Therefore, employees shall be provided with personal fall-arrest equipment to attach to an anchor point if available. In case of delivering roofing materials, the following is required.

Gaining Access to a Roof: Where a vendor or supplier's employee gains access to a roof is a handhold (rope, chain, or other railing) required to be attached to the conveyor belt in order for the employee to have a support with which to steady him or hers; or a ladder shall be used to gain access to the roof?

Discussion: Distribution of Roofing Materials: Once on the roof, the vendor's employee will receive roofing products from a conveyor belt (lift truck or similar equipment), and then distribute the products onto the roof at various locations. During this distribution, OSHA does not require the vendor's employees to install anchorage point for fall-protection equipment, regardless of the slope of the roof or the fall distance. The construction contractor shall establish/identify properly designed anchorages to be used by vendor's employee.

Additional Discussion: It is recommended that the employee be tied to an anchorage point at the ridge or the highest point on the roof. The anchorage point can have a post four to five feet high attached to it, so that a self-retracting lanyard or lifeline attachment to the “D” ring will be high enough and won’t become a tripping hazard.

C.3. FALL PROTECTION REQUIREMENTS FOR SCAFFOLDS

Question: What type of fall protection equipment will be required for work on scaffolds?

Answer: A fall-arrest system, vertical lifeline, and temporary guard system will be required on movable or suspended scaffolds. For a scaffold attached to a building or structure (stationary), workers shall use temporary guard systems. However, fall-arrest systems or horizontal or vertical lifelines on stationary scaffolds are recommended. A warning-line system is required at the lower level.

C.4 REQUIREMENTS FOR INSPECTION AND CERTIFICATION PROCESS FOR HORIZONTAL LIFELINE (HLL) SYSTEMS

Question: What is the difference between the inspection and certification process?

Answer:

Inspection: The act of verifying conditions of a system, assembly, or component. Inspection should be per established standards and criteria with a means in place to correct deficient conditions. The inspector shall be trained for the inspection task.

At Navy and Marine Corps facilities, the horizontal lifelines shall be considered fall protection equipment requiring annual inspection. Inspection of HLL components should include anchorage connectors, lifeline tensioner, thimble, cable, fittings, snaphooks, self-retracting lanyard shock absorber, lanyards, and full-body harness. Inspection should follow ANSI Z359 Fall Protection Code/ standards inspection process or OEM instructions, or if produced locally, by the qualified engineer.

Certification: The process resulting in documentation that the criteria established for the design of the system and inspection requirements is met. Each activity that installs HLL shall develop a certification process that evaluates the design of the assembly and provides inspection criteria.

Standards and requirements: Certifying HLL Systems is carried out by testing or applying proven analytical methods under the supervision of a qualified person.

The responsibility of certifying HLL lies with the activity that owns or uses the system. Navy activities should take into consideration when selecting or designing HLL systems that these systems will require annual or periodic inspection. The system will also require certification and recertification by a qualified person/engineer. Navy Activities should budget funds for this effort. The frequency of re-certification shall be provided

August, 2013

by the designer of the system. The duration of re-certifying the system shall not exceed 5 years.

C.5 RISK OF EXPOSURE TO HIGH WINDS

Question: What is the maximum wind velocity to which an employee should be exposed while performing a task?

Answer: Not all fall-protection standards address exposure to high winds; however, 29 CFR 1910.269, titled "Electric Power Generation, Transmission, and Distribution; Paragraph (x) (5)" defines: "High Winds as a wind of such velocity that the following hazards would be present:

- [1] An employee would be exposed to being blown from an elevated location, or
- [2] An employee or employee operating material-handling equipment could lose control of the materials being handled, or
- [3] An employee would be exposed to other hazards not controlled by the standard involved."

Where work is performed on roofs when the possibility of adverse weather conditions may be present, such as wind, ice, or rain; extra caution must be exercised. The Safety manager or a Competent Person must be consulted where the work is occurring, with consideration of the duration of work, the number of employees, and whom to contact in case of adverse weather.

Note: Winds exceeding 40 miles per hour or 30 miles per hour where material handling is involved, is normally considered as meeting this hazard-prevention criterion, unless precautions are taken to protect employees from the hazardous effects of the wind.

C.6 REQUIREMENTS WHEN ACCESSING AND PERFORMING WORK ON ROOFS

Question #1: Can a "Competent" Person for Fall Protection access a rooftop through a Hatch/door, close the hatch/door and proceed directly to the area of work without a warning line system, and tie off at destination?

Answer: Yes, for Government work (General industry work) per Navy requirements and guidelines and 29 CFR 1910 Proposed Rule for walking working surfaces which will be finalized Summer of 2013, a competent person for fall protection or an end user can enter a rooftop thru a hatch/door, close the hatch/door, and proceed directly to the work location with no fall protection. This however, is only for accessing the work location, but when the work is being performed on HVAC equipment a FP method is required. A warning line system is only used for construction work, for general industry work (i.e. inspecting or maintaining HVAC equipment), "Designated Area Method" is used which is similar to a warning line system (WLS); in addition to WLS requirements, an access to the designated area from the hatch/door must be established by a clear path formed by two lines attached to stanchions. Requirements for this safe access are similar to the requirements for designated area. That being said, the first-person-up can access the work location and establish an anchorage or

August, 2013

install a designated area method, FP is not required during this process. This is called "The First-person-Up". However, when the work is being performed on the equipment then fall protection is required (this is after installing a FP method).

No matter how far the work location is from an unprotected roof edge or the duration of the work, fall protection will be required. As Per the OSHA interpretation letter and Navy instructions and guidelines, we have included the following paragraphs:

a. There is no safe distance from an unprotected side or edge of a roof or floor. The distance alone is ineffective to protect personnel from unprotected sides and edges.

b. There is no minimum time duration that allows exclusion of fall protection requirements. (e.g. if a 2 minute job requires 15 minutes to establish fall protection).

Question #2: Can a Contractor proceed in the same manner as above?

Answer: The answer to the second question is yes; the contractor performing construction work (only the first person up) can proceed in the same manner for accessing the roof or other high locations and said contractor can install a fall protection method or an anchorage without being protected. The first person up has ONLY one job, and that is installing a Fall Protection method. And again, when the work is being performed on equipment FP has to be in place. There are other feasible FP methods that can be used, other than a warning line system or the designated area method, for example; a temporary railing and restraint system if anchorages are available.

Question #3: Once "Tied Off" at a designated tie off point, is a Warning Line System still required if the Government/Contractor employee remains tied off until their work is completed?

Answer: When a person is tied off using the proper personal FP equipment a warning line is not required, one system is adequate. The only time fall protection is not required is during inspection and investigation work conducted on roofs for the purpose of replacing roofing material or inspecting (i.e. a puddle of water). This applies to Government personnel and contractor worker, and this requirement is included in the FP Guide and EM 385. Such an inspection would fall under the "Construction Exemption". If a person is conducting a roof inspection and investigation work, and said work is within 6 feet from an unprotected roof edge then fall protection is required. Any inspection and investigation work conducted more than 6 feet away from the unprotected side or edge fall protection is not required. Any work involving equipment inspection or maintenance work on roofs (other than roof inspections) falls under the general industry standard and again FP is required.

As a point of note; the EM 385 Section 21 and Navy FP Requirements are almost identical, any differences that exist will only be in the application of the requirements and not the substantive directives.

End of Section

August, 2013

APPENDIX D

MAN OVERBOARD PLAN

1. REQUIRED EQUIPMENT

a. **Personal Floatation Devices:** U.S. Coast Guard-approved life jacket or buoyant work vests will be provided for employees working over or near water, where the danger of drowning exists. PFDs (life preservers, life jackets, or work vests) worn by each affected employee shall be United States Coast Guard (USCG) approved pursuant to 46 CFR part 160, Coast Guard Lifesaving Equipment Specifications (Type I, II, III, or V PFD) and marked for use as a work vest for commercial use, or for use on vessels. Prior to each use, personal flotation devices shall be inspected for dry rot, chemical damage, wear, moisture damage, and ultraviolet deterioration that may affect their strength and buoyancy. Defective personal flotation devices shall not be used.

b. **Ring Buoys:** USCG-approved 30-inch ring buoys (life rings/safety buoys) with at least 90 feet of 600 pound capacity line shall be provided and readily available for emergency rescue operations. Distance between ring buoys shall not exceed 200 feet. Prior to each use, personal ring buoys shall be inspected for dry rot, chemical damage, wear, moisture damage, and ultraviolet deterioration that may affect their strength and buoyancy. Defective ring buoys shall not be used.

c. **Lifesaving-Skiff:** At least one lifesaving-skiff shall be available immediately at locations where employees are working over or adjacent to, water where the danger of drowning exists. It is intended that the lifesaving-skiff shall be able to retrieve an employee from the water within no more than three (3) to four (4) minutes from the time of entrance into the water. Additional hazards such as very cold water, strong current, heavy winds, and/or wave conditions shall be noted. The ability to retrieve an employee before injuries are sustained as a result of these additional hazards, and whether it is powered by an inboard engine, will determine the size of the lifesaving-skiff. The lifesaving-skiff shall be properly maintained, ready for emergency use, equipped with oars & oarlocks attached to the gunwales, boathook, anchor, ring buoy with 50 feet of 600-pound capacity line, and two life preservers. (Oars are not required on a lifesaving-skiff powered by an inboard engine.) The lifesaving-skiff shall be manned at all times when employees are working near or over the water. The lifesaving-skiff operator must be trained never to reverse the skiff's engine and approach an employee who has fallen into the water by backing the skiff stern-first, as the propeller may strike the victim. The lifesaving-skiff shall carry a boarding ladder so that the person, if able, can climb into the skiff.

d. **Fall Protection Temporary Guardrail System or Personal Fall Arrest System:** Fall protection shall be provided during construction/erection activities where employees are working 6 feet above lower level surfaces, including water. In cases where 100% fall protection, including the use of temporary guardrail systems or personal fall arrest systems, is used to prevent employees from falling into the water, the drowning hazard effectively will have been removed; therefore life jackets or buoyant work vests are not required. Ring buoys

August, 2013

and a skiff shall be used as a backup in the event of a failure of the operation of fall protection devices, or a lapse in their use (therefore, ring buoys and a lifesaving-skiff shall be provided, irrespective of the fall protection provided on the construction/erection site).

e. Available Ladder: There shall be at least one portable or permanent ladder in the vicinity where the work is being performed so that in the event that an employee falls into the water, and if the employee – if not injured, exhausted, or unconscious, will be able to use the ladder to climb out of the water. The ladder shall be of sufficient length so that the employee can step onto the ladder rungs, regardless of the height of the tide.

f. Lifejacket Rescue Light: Employees working over (or near) deep water after dark shall have a flashing/strobe or constant beam (visible for at least 1 mile in clear dark conditions) light attached to their PFD. [Note: some PFD lights are activated automatically upon contact with water].

g. Emergency Whistle: Employees working over (or near) deep water in foggy conditions shall have attached to their PFD a pea-less omni-directional whistle with at least a 115 decibel volume capacity (at 10 feet). [Note: pea-less whistles have no cork ball or pea that can swell up or stick when immersed in water].

2. SAFETY TOOL BOX MEETING

The *Man Overboard (Person Overboard) Plan* shall be discussed at an employee safety meeting, with all involved employees in attendance, prior to work near or over water. It shall be pointed out at the meeting that employees who fall into the water face a number of dangers, including panic and injury during the fall; and if the fall is into cold water, the employee may experience hypothermia. Quick thinking and coordinated action are essential to an effective rescue. Rehearsal of reaction method(s) is vital to a successful and safe recovery of an individual who falls off a pier, dock, or platform into deep water. *Man Overboard Rescue Procedures* shall be discussed at the Safety Tool Box Meeting. This discussion shall include addressing the visibility conditions (working in a foggy environments or after dark), weather conditions (high wind and/or high waves), and climate conditions (winter months in Northern climates). If the work is being performed near or over cold water, there shall be a discussion on the water survival skills to be utilized to increase the chances for surviving cold water immersion, including the following:

a. Immediately upon falling in the water, try to catch your breath, and become oriented to the surrounding area.

b. Try to get onto the pier or on board the lifesaving skiff, as soon as possible, to shorten the immersion time. (Body heat is lost many times faster in the water than in the air.)

c. While afloat in the water, DO NOT attempt to swim unless you are able to quickly reach the pier's safety ladder, or get to the lifesaving-skiff's rescue ladder. (Unnecessary swimming will pump out any warm water between the body and the layers of clothing, and will increase the rate of body-heat loss. Also, unnecessary movements of arms and legs send

August, 2013

warm blood from the inner core to the outer layer of the body, resulting in more rapid heat loss.)

3. **MAN OVERBOARD RESCUE PROCEDURES**

a. **Shout “Man Overboard”**: The first construction/erection crew member to observe the incident or the person overboard calls out “Man Overboard!” (Even if there is only one person on the shore in the immediate area, shouting “Man Overboard”, it may provide reassurance to the person in the water).

b. **Maintain Sight of the Victim**: The person who has fallen into the water must be kept in sight at all times. One employee on shore shall continuously point (open handed) to the individual in the water. (Even the best of swimmers can become disoriented when unexpectedly falling into the water.) Immediate action is of primary importance when a person falls overboard. Every second counts, particularly in windy conditions or cold weather. The condition of the person in the water will dictate the type of recovery procedure used.

c. **Throw Ring Buoy**: A tethered ring buoy immediately shall be thrown to the person who falls into the water. Throw the ring buoy directly in front of the person in the water (ahead of the person in the direction of the moving water); do not throw it directly at the person because it could cause further injury if it hits the individual. The person in the water will be directed to hold onto the line and be hauled in for recovery by the person on the shore tending the line.

d. **Sound a Signal**: Where there are boats in the area, sounding five or more short blasts on a sound signal, horn, or whistle (e.g., hand-held emergency whistle) will alert boats in the area that a danger exists (i.e., a person is overboard). (Boats in the vicinity may not be aware of what the signal means, but at least they will realize something unusual is happening.)

e. **Call 911**: Call 911 by using a mobile or land phone, or contact emergency personnel by Marine VHF radio. Assume that the person who is in the water is suffering from shock, may be unconscious, and possibly injured.

f. **Lifesaving-skiff**: If the person who falls into the water easily and quickly cannot be pulled via the ring buoy to an available ladder to climb out of the water, or if the person who falls into the water is weak, injured, exhausted or unconscious; then the lifesaving-skiff shall proceed to rescue the person in the water. If, however, wind, wave conditions, maneuverability of the skiff, or maneuvering space restriction prevents the safe approach to the individual in the water by the lifesaving-skiff; then rescue by a surface swimmer shall be considered.

g. **Water Rescue by Swimmer**: Employees who attempt a rescue shall be counseled that they are to go into the water after the victim **only** as a last resort. Surface swimmers are any swimmers not trained as rescue swimmers. Their training is accomplished through Personnel Qualification Standard (PQS). They are deployed from floating units, piers, or the shore. A surface swimmer must wear a PFD (with dry suit or wet suit in cold water) and a swimming harness with a tending line. Another person will tend the harness whenever the swimmer is in the water. When the surface swimmer has reached the unconscious or injured victim and has

August, 2013

obtained a secure hold on the person, the person tending the harness line will haul both back to the shore. (Water rescue by a swimmer without a personal floatation device should never be attempted unless the person doing the rescue has had advanced training in lifesaving. Too often the would-be rescuer becomes another drowning victim.)

h. Getting Victim onto the Shore or into the Skiff: Getting the person onto the shore (pier) or onto the skiff can be difficult. A person is light in the water due to buoyancy; however, once free from the water the person becomes “dead weight.” Keep this in mind and be especially careful when recovering injured persons.

(1) Where the pier has a ladder to the water and/or the skiff has as a boarding ladder and the person in the water is able to climb out, use it if it is safe to do so.

(2) If the person in the water needs assistance, two people could be used to pull the person up out of the water and onto the pier or the lifesaving-skiff, by each placing a hand under the person’s armpit or the use of a recovery strap (the strap should cross the chest, pass under each arm, and up behind the head). The rescuers should physically pick the person straight up out of the water to a sitting position on the pier or on the gunwale of the lifesaving-skiff. Be careful not to drag the person’s back across the rail.

(3) If the victim is unconscious or exhausted, and the person is corpulent, a form of lifting gear with appropriate lifting slings and necessary rigging needs to be considered. A short rope or strap with its ends spliced to form a loop used in conjunction with a block and tackle rigged on the end of a halyard would make it easier for a heavy casualty to be lifted onto the pier.

End of Section

August, 2013

APPENDIX E

GUIDANCE DOCUMENT-DESIGN CONSIDERATIONS FOR MANAGEMENT OF FALL HAZARDS

INTRODUCTION

Architects, engineers, and other designers, whether Navy or contract (A/E) personnel, can play a major role in assisting contractors to protect their workers during the construction phase, and also in making it safe to manage fall hazards associated with working at heights on existing buildings and facilities during the maintenance phase. Designers should play a major role in making it easier and safer to manage fall hazards associated with working at heights.

Falling from height is the most common cause of fatal mishaps on construction sites, and one of the leading causes in general industry. Often mishaps occur because fall protection had either not been provided, or used incorrectly.

In many cases, the design is such that the provision of fall protection either is not practicable, or requires workers to work beyond the confines of the protection provided. In such circumstances, designers should attempt to prevent the development of conditions in which an accident can happen.

Nevertheless, in many instances work at height is necessary and cannot be avoided. Even so-called low-rise buildings and structures have some components or equipment on roofs (e.g. HVAC equipment, chimneys, penetrations, etc) that require working at heights.

Information from mishap reports show that there are five main reasons why workers fall to lower level. These are:

- a) Poor workplace design;
- b) Means of access collapsed (e.g., scaffolds, ladders etc);
- c) The worker was required to work beyond the confines of the protection provided; thus exposing him to fall hazards;
- d) Edge protection was inadequate, not provided, or of poor design or construction; or
- e) Restrictions placed on the movement of workers did not accommodate the construction activities, and hence were ignored.

It is of the utmost importance for architects and engineers to know how a contractor will build or construct a building or facility, and to understand the required subsequent maintenance work. Knowledge of construction and maintenance operations will help architects and engineers to design safer buildings and facilities, and to specify the proper materials and equipment. These efforts will help contractors during construction operations, and protect Navy and contract personnel who perform maintenance work after construction is complete.

Management of other hazards is also addressed in this guidance document because the hazards are either directly or indirectly related to fall hazards.

End of Section

1. MANAGEMENT OF FALL HAZARDS DURING CONSTRUCTION

(DESIGN FOR CONSTRUCTION SITE SAFETY)

1.1 MANAGING FALL HAZARDS DURING ROOF CONSTRUCTION

Roofs are hazardous places to work, because they are at height and utilize roofing materials which are lightweight and often fragile, and may deteriorate over time due to weather exposure and other environmental factors. While work on roofs is an infrequent activity, the risk of a fatal or serious mishap is very high. Designers who see roofs only as a means of making the building water-tight may exacerbate the situation. They may forget that people have to construct roofs and maintain them. Consequently, inadequate consideration may be given to worker safety. Workers often are killed or injured when falling from heights; therefore, designers should consider alternative designs to ensure that repeated roof work can be eliminated or significantly reduced. Falls from roofs can occur either from an unguarded edge or through a fragile surface (premature collapse).

The following considerations can make A/Es aware of these issues, and may provide information on how they can assist contractors to make roof work safer by design.

1.1.1 FALLS FROM UNGUARDED EDGES

Roof construction can create an advancing unprotected leading edge, and the risk from falling from this edge; therefore, designers should consider the following provisions to protect the workers from this hazard:

- a) Provide effective anchorage points for attachment of safety nets;
- b) Where (a) is not possible, make provision for anchoring a personal fall arrest system to structural members with sufficient strength; and
- c) Optimize the locations of close-under-the-roof obstructions (i.e. service ducts that are in the deflection zone or path of fall arrest equipment); and
- d) Consider the provision of parapets. This will eliminate unprotected roof edges for some construction workers and for those who perform subsequent maintenance work.

1.1.2 FALLS THROUGH ROOFS

Specify roofing substrate materials of appropriate strength and rigidity. For other than temporary structures, avoid materials subject to rot or damage by insects or other vermin. Specify plywood sheets (do not specify particle board for roofing material).

1.1.3 FALLS CAUSED BY PREMATURE COLLAPSE OF STRUCTURES

Individual plywood sheets do not weigh a lot. However, the weight of a stack of sheets is significant. Therefore, ensure that the roof structure can carry these loads and make sure the roof decks can provide adequate support for workers as they are being installed.

August, 2013

1.1.4 PROVIDING FOR CRANE PLACEMENT OF MATERIALS

Site the building to ensure that there is enough space to locate and use a crane so that every part of the building is within its lifting capacity.

1.1.5 MINIMIZING THE RISK OF MATERIAL MANUAL HANDLING

Decking materials must be maneuvered into position by contractor's workers. Try to limit their size.

1.1.6 CONVEYING FALL HAZARD INFORMATION TO THE CONTRACTOR

After completing the design, designers shall provide contractors with sufficient information to allow them to control residual or other hazards, including information about the issues discussed above.

1.2 MANAGEMENT OF FALL HAZARDS IN OTHER PARTS OF BUILDINGS OR STRUCTURES

1.2.1 DESIGN CONSIDERATIONS WHEN WORKING AT HEIGHTS

Designers have a major role in providing safe design, and in eliminating or preventing the need to work at height, to the extent possible. For example:

- a) Excavation for retaining walls can be designed as contiguous bored piles installed from existing ground level. This would eliminate shuttering and pouring concrete at height.
- b) Trusses and other structural members should be designed to allow pre-assembly and lifting (this also will reduce construction cost by eliminating field assembly).
- c) Floor height in buildings should be designed so that temporary support structures needed during construction can be installed from the floor below; however, if work at height cannot be avoided, designers should aim to assist the Contractor by applying the following control measures:
 - 1) Facilitate the provision of fall prevention measures to make temporary work at height during construction safe (e.g., install temporary guardrails at the perimeter of the structure prior to erection);
 - 2) Facilitate the use of temporary access equipment (e.g., scaffolds).
 - 3) Facilitate the provision of fall arrest measures.
 - 4) In addition, the design should eliminate any requirement for personnel to work outside the confines of the edge protection.

1.2.2 FACILITATING THE PROVISION OF FALL PROTECTION MEASURES

Workers are most vulnerable when working near the perimeter of a structure or when working close to leading edges inside the structure. The design should limit the exposure of workers to such fall hazards. As an example, designers can:

- a) Specify composite flooring which will support erection loads, to allow placing of formwork immediately after the support frame is complete. Designers should minimize the need for people to work at height to erect false-work to temporarily support floors. (False-work is any temporary structure built to provide support for permanent structure until it becomes self-supporting.)
- b) Specify attachments for temporary edge protection on perimeter members (e.g., tubes welded to structural steel members or securely attached to cast concrete members);
- c) Position splices for steel columns at approximately 42 inches above floor level. This will allow splicing from a completed protected floor, and will also serve as guardrails;
- d) Consider specifying pre-cast concrete for slabs and other components of the building and structure, potentially to reduce the time and expense of working at height;
- e) Specify permanent stairways to be installed early in the construction phase to avoid the need for temporary access.

1.2.3 FACILITATING THE PROVISION OF SAFE AND TEMPORARY ACCESS TO WORK AT HEIGHT DURING CONSTRUCTION

Temporary access equipment (e.g., scaffolds and towers) need to be tied to the building or structure at regular intervals; to provide restraint against buckling and overturning. This is particularly important with façades where glazing predominates.

1.2.4 FACILITATING THE PROVISION OF SAFETY NETS, FALL ARREST AND OTHER PROTECTIVE MEASURES

The most commonly used fall protection systems are safety nets and personal fall arrest systems.

1.2.4.1 Safety Nets

When safety nets are considered as a fall protection measure, designers should reference ANSI A10.11 Standard regarding the use, testing and certification requirements of safety nets.

General considerations include:

- a) Comparison of the capacities and applications of safety net systems offered by several suppliers before developing the design;
- b) Where safety nets are to be attached to a structural grid, designers should:
 - i) Check that the grid will resist lateral loads, especially when nets are attached to steelwork in composite construction or to purlins in roof work;

August, 2013

- ii) Ensure that the net installation attachment points are located as close as practicable under the walking working surface to minimize the distance of the fall. In addition, ensure that the safety net can deflect safely when a worker falls into it.
- c) Consider restricting service runs to limited areas such that they cannot obstruct a fall into a net or prevent the net from deflecting;
- d) Consider restricting the net area enclosed by the grid.

Safety nets are often installed from mobile elevating work platforms; therefore, designers should allow for the concentrated loads applied by the platform wheels/outriggers of the equipment on the ground.

1.2.4.2 Fall Arrest System

Fall arrest systems must be attached to suitable and sufficient load-bearing anchors; therefore, contractors should:

- a) Provide anchorages capable of supporting 5,000 lbs, or designed for twice the maximum arrest force;
- b) Be aware that:
 - i) Energy absorbing lanyards should be as short as possible (Six feet or less),
 - ii) Impact of fall forces are minimized when the anchorage is located above the worker;
 - iii) Lanyards can be cut by sharp edges (Chafing material will be required);
- c) Show clearly where these anchorage are located;
- d) With horizontal lifelines the forces imparted by a fallen worker on the anchorages may be greatly in excess of 5,000 lbs; therefore, the manufacturer of the horizontal lifeline system should be consulted for advice.

1.2.4.3 Other Control Measures

For steel erection, designers should consider the provision of holes in flanges of columns and beams, where:

- a) Holes in columns should be drilled at 21 and 42 inches above the beams, so that a cable can be strung between the columns and used as a temporary guardrail system;
- b) Holes in beams should be at a maximum of 6 feet on centers.

August, 2013

For pre-cast concrete, designers should specify anchorages and requiring the following information:

- a) Depth of embedment in concrete;
- b) Anchorages should be located as far as possible behind the leading edge.

1.3 MANAGEMENT OF HAZARDS ASSOCIATED WITH THE ERECTION OF STRUCTURES

Designers can play a major role in making it easier to manage fall hazards associated with erecting structures. Some designers have been found to have a narrow view of design, that it requires structural analysis followed by detailed design. This is not adequate, the designers need to take into consideration that something will be erected or constructed followed by how it will be maintained and, in due course, demolished.

1.3.1 HAZARDS ASSOCIATED WITH STRUCTURAL ERECTION

The erection of structures requires contractor's workers to work on partially complete structures, where they are exposed to hazards associated with instability and working at height. In addition:

- a) Workers often have to work in proximity with equipment or machines (e.g., cranes) which are used during the erection of the structures;
- b) Sometimes, unplanned work exposes them to health hazards, which arise from the application of a remedial process (e.g., cleaning and then painting corroded steel); and
- c) Delays in construction could mean that many tradesmen are working in close proximity, under or above others.

Therefore, hazards associated with erecting structures and associated temporary works may be summarized as including:

- a) Temporary instability;
- b) Falls from height;
- c) Lifting: Overturning of cranes;
- d) Working on or near fragile or unstable materials;
- e) Handling heavy unwieldy loads;
- f) Collapse of temporary equipment;
- g) Danger to adjacent properties.

WHAT SHOULD DESIGNERS DO?

In order to prevent, (as much as possible), workers' exposure to fall hazards, designers should consider the following:

1.3.2 DESIGNING TO MINIMIZE TEMPORARY INSTABILITY

Structures in their temporary state could become unstable for many reasons, these may include:

- a) Omission of temporary support work, which usually occurs when the design is out-of-the-ordinary and usual erection practices are insufficient. Examples of out-of-the-ordinary designs may include the following:
 - i) Slender rafters, which require additional bracing until the strength of the roof is adequate;
 - ii) Portal frames where the cladding contributes to sway stability;
 - iii) Long-span structural members, which require bracing until another one is connected (e.g., some bridge beams).
- b) The partially-erected structure is inherently unstable, which could occur when:
 - (i) It is stabilized by other (remote) parts of the permanent parts or components (e.g., shear walls, shear cores or adjacent structures);
 - (ii) Provision for lateral stability is either by asymmetrical bracing or contributed by other structural members to be added later (e.g., cladding);
 - (iii) Due to design, the structure is subjected to significant un-anticipated construction loads (e.g., when the assembled roof is being lifted or when masonry walls are loaded too soon);
 - (iv) A structural member has inadequate seating when placed on another member in the temporary state, because erection tolerances add up unfavorably, such as:
 - Pre-cast slabs on narrow-flange beams,
 - Purlins on main rafters,
 - Beams erected on corbels.
 - (v) Structural members in isolation cannot sustain normal erection loads such as:
 - Pinned-base columns under lateral loads from ladders,
 - Long-span beams and trusses
- c) Temporary support structures are removed prematurely, which usually occurs when a structure is apparently complete, such as where:
 - (i) Composite beams and panels support "green" concrete,

August, 2013

(ii) Portal frames rely on ties into the floors to carry significant horizontal thrust at their base;

(iii) Guying systems are supporting columns.

While it is desirable for designers to eliminate these hazards by design, at a minimum the designers should:

- a) Advise the Contractor that these hazards exist; and
- b) Inform the contractor about design assumptions and design forces, such as the magnitude of construction loads allowed, portal base, horizontal thrusts, etc.

1.3.3 DESIGN TO MINIMIZE FALLS FROM HEIGHT

During the erection of structures, workers often find themselves in precarious positions (e.g., straddling unattached beams, working towards an open edge, etc.). Although these hazards are the liability of contractors on site, designers should give consideration to details, which could help to limit workers' exposure to fall-hazards, or provide other prevention or control measures, for example by:

- a) Contacting multiple suppliers of temporary edge protection, and discussing with them methods for features of their products to be integrated into the design of the permanent components of the structure;
- b) Designing structural components or elements which will allow the attachment of anchorages for using fall arrest/restraint systems or safety nets, where appropriate;
- c) Accounting for erection and manufacturing tolerances to minimize the need for vigorous material manhandling while slung at height, such as: placing concrete slabs on steelwork or erecting steel beams between columns;
- d) Specifying a good quality sub-base for concrete slabs on ground, which would carry the loads from the necessary cranes and mobile platforms required for the erection of the building envelope;
- e) Removing the need for some work at height (e.g., getting rid of sag bars for purlins).

1.3.4 DESIGN TO MINIMIZE HAZARDS WHEN USING CRANES

This usually means being aware of the conditions under which a crane could overturn or collapse. While it is not always possible to limit the weight of components: members or frames, or the radius over which they have to be lifted into position, designers should give consideration to the following:

August, 2013

- a) Cranes need working room; therefore, avoid heavy lifts or large lifting radii on congested sites;
- b) The radius of a lift limits the weight that a mobile crane can lift; even moderate weights lifted over a large radius could create a lifting hazard;
- c) It is always helpful to know the weight of the loads being lifted. Therefore, inform the crane operator about maximum loads of components;
- d) It is essential to know where the center of gravity is, especially if it is not in the center of the load;
- e) Identifying lifting points is always helpful;
- f) Cranes need good foundations therefore do not specify designs loads which require heavy lifting on sites where the soil is poor;
- g) On exposed sites, the effect of wind velocity on assemblies with large effective areas could create a lifting hazard;
- h) Long-span and large section beams have a significant momentum when they start to swing.

Where the design includes heavy or moderately heavy loads to be lifted over a large radius, discuss the options with the manufacturer and supplier of the crane to be used.

1.3.5 WORK ON OR NEAR FRAGILE OR WEAK MATERIALS

This is a problem largely, but not solely, associated with roofing. Designers should specify only non-fragile and strong components and assemblies.

1.3.6 HEAVY OR UNWIELDY LOADS

This is a problem of specification. If lighter weight alternatives exist, specify them instead. For example:

- a) Use light weight concrete blocks or bricks instead of heavy ones. Where heavy blocks are unavoidable (i.e. for acoustics, specify half size blocks to reduce the weight).
- b) Where steel sections must be lifted manually (e.g., some lintels), consider the most appropriate sections which satisfy the loading requirements.
- c) Where standard details govern the specification, discuss the possibility of moving heavy objects with the lift equipment.

August, 2013

Where it is not possible to specify less-massive alternative products, inform the contractor about their weight, or investigate whether or not mechanical installers exist, and design these components to be compatible with their use. For example, machines are available to install heavy glazing units and concrete curbs.

Even “light weight” components can be unwieldy and difficult to manhandle if their shape is unusual or the center of gravity is far away from the geometric center. Therefore designers should consider:

- a) Providing seating cleats for such members;
- b) Incorporating lifting points, which allow vertical and horizontal members to be dropped into position vertically and horizontally.

1.3.7 COLLAPSE OF TEMPORARY WORK EQUIPMENT

While it is not the duty of architects and engineers designing the building or structure, it is recommended that consideration be given to the design of temporary support structures; especially when the design incorporates components which could be used to stabilize the temporary support structures (e.g., by recommending methods for tying the scaffold to the structure).

1.3.8 DESIGN TO MINIMIZE DANGER TO EXISTING ADJACENT STRUCTURES

Sometimes, the location of existing buildings or structures can limit or make erection processes difficult. For example:

- a) Noise and ground vibrations may not be acceptable (e.g., near hospitals);
- b) Excavation may not be possible close to canals or other watercourses;
- c) Crane operations may be restricted by a number of constraints. Designers should include measures into the design to protect adjacent structures.

1.4 MANAGING HAZARDS DURING STEEL ERECTION

Erecting steelwork can expose workers to several fall hazards. During construction, it is the contractor’s duty and responsibility to protect workers exposed to such hazards. However, designers can help contractors by taking into consideration other alternative measures, which will reduce workers’ exposure to these hazards.

Designers should be aware that the state-of-the-art in erecting steelwork is changing. Increasingly, it is being erected using work platforms, and designers should be aware of how this might affect their design or using horizontal lifeline systems on pre-installed beams (using stanchions).

1.4.1 HAZARDS ASSOCIATED WITH ERECTING STEELWORK

The erection of steelwork requires people to work on partially complete structures, and usually the work is performed at height. In addition, steel erectors are often exposed to other hazards associated with:

- a) Working in proximity to machines or equipment (e.g., cranes);
- b) Unplanned work (e.g., remedial processes that could expose workers to health hazards); and
- c) Program delays, which could result in trades' working near, beneath, or above others.

The hazards associated with erecting steel structures and working on associated temporary works may be summarized as follows:

- a) Temporary instability;
- b) Falls from height – people and objects;
- c) Lifting components (exacerbated by site constraints);
- d) Handling heavy loads; and
- e) Collapse of temporary equipment or inadequately connected structures.

WHAT DESIGNERS SHOULD DO

Designers should give consideration to measures which either will remove or lessen or minimize these hazards.

1.4.2 DESIGN TO MINIMIZE TEMPORARY INSTABILITY

Usually, steelwork is erected piece-by-piece. Therefore, at any time there is a chance for frame instability. However, the risk of instability can be reduced by some fairly simple measures, which include:

- a) Provide bracing between the first two bays to be erected, to form the basis of a braced erection;
- b) Checking all steel members for assumed erection loads. Particularly vulnerable structural members may include:
 - i) Long-span (slender) members;
 - ii) Floor beams, especially when they are part of a composite system, due to:
Stacks of profiled steel forms;

August, 2013

Torsional effects of placing concrete panels on one side of the flange;

Concrete discharged in a heap; or

Other foreseeable storage;

iii) Roof beams, especially portal rafters, for stacks of profiled roofing assembly materials;

c) Design bracing to be symmetrical;

d) Ensuring that plan bracing connects into vertically braced bays;

e) Design columns as free-standing cantilevers during erection, to resist short-term erection loads such as wind loads, ladder lateral forces, etc., meaning that pinned columns (e.g. Two bolt connections) may not be adequate;

f) Ensuring that design effective lengths can be achieved by assumed construction techniques;

g) Ensuring that slender members can resist the compression imposed by lifting/rigging slings (e.g. the components of the sling forces). If there are restrictions on sling angle, inform the contractor, to allow the contractor to design the lifting points;

h) Consider worker fall protection forces;

i) Design bases for portal and arch-type structures to resist the lateral thrusts developed at their bases;

j) Where aerial work platforms are to be used, their loads on the partially erected structure must be accounted for.

After performing these checks, designers should act as follows:

a) Inform the contractor about all design assumptions including erection load allowances, lateral stability when it is by other means (e.g., diaphragm action of floors or cladding, or by shear cores or when symmetry cannot be achieved), and the magnitudes of the forces.

1.4.3 DESIGN TO REDUCE THE HAZARD OF FALLING FROM HEIGHT

Falls from height can occur from any unprotected side or edge. Designers should give consideration to measures which would protect workers from fall hazards, by reducing the time they have to spend at height and by designing in provisions for worker protection.

To reduce the time workers spend at height, designers could:

a) Design to maximize prefabrication (i.e. portal frames to be erected flat and lifted to vertical);

b) Limit the number of bolts in connections;

August, 2013

- c) Minimize components (e.g. purlins);
- d) Design buildings with fewer members;
- e) Use concrete floor construction in preference to profiled steel forms, which need bolting down.

Workers are most vulnerable when the steel is ready to receive subsequent components (e.g., concrete floor units, profiled steel formwork, roof assemblies, etc.), which create an advancing unprotected leading edge. Therefore, designers should consider means for attachment of the fall arrest system. For example, designers could:

- a) Design parapets at the roof edges having minimum height of 39 inches (instead of 30 inches, for example), which would act as compliant guardrail. This increase in height to 39 inches will increase the wind load at the base of parapet. The parapet has to be evaluated structurally because the wind stresses at the base will be proportional to the square of the height.
- b) Provide holes in column flanges at least 6 feet above floor steel level for connecting the lanyards to the anchorage which is capable of supporting 5,000 lbs force;
- c) Specify the provision of anchorages in sequential components, (e.g., concrete units and profiled steel forms);
- d) Ensure that the structural steel members can resist the loads from safety net anchorages, and specify net anchorage components;

In addition, access to the work place at height, should, wherever possible, be provided by permanent staircases, which have been designed for construction loads (possibly as free-standing structures).

To assist erectors in making structural connections at height, designers should consider the provision of seating cleats, pre-attached to columns.

Where structural steel sections are to be connected to other components (e.g., concrete) the brackets for these connections should be installed in the process of construction of the other component (e.g., cast into the concrete). This could be more of a problem in existing buildings.

To prevent falls through roofs, designers should only specify non-fragile assemblies, in which all the components are non-fragile. [This would also mean that removal of components for maintenance work would not render the remaining assembly non-fragile].

Where the steelwork is to support horizontal lifelines, designers should consult fall protection experts about the magnitude of the fall forces that may need to be resisted by the steel stanchions or the structural members.

1.4.4 REDUCTION OF HAZARDS ASSOCIATED WITH CRANES

To facilitate the lifting of structural steel members, designers should:

- a) Consider the space requirements for cranes;
- b) Consider the provision of lifting points and specify these as an item for the fabricator to design;
- c) Design structural members to resist loads from lifting points (e.g., sling component loads);
- d) Where necessary, ensure that the spacing of purlins allows for the largest component to be lowered between them with sufficient clearance;
- e) Show on shop drawings, the maximum length of the piece or weight to be lifted and its location (to allow the contractor to select the appropriate crane);

1.4.5 MANHANDLING OF LOADS

This problem occurs mainly, though not exclusively, on renovation projects, where, due to the situation of the work (e.g., inside an existing building where cranes cannot be used), workers are often required to manhandle steel members into position. To facilitate this, the weight of the individual structural steel members should be minimized by:

- a) Designing beams with splices, to allow piecemeal installation of the beam, and maneuvering in limited spaces;
- b) Replacement of one section with two, instead of a single section;

In addition, structural steel members should be detailed with site constraints in mind. For example, where members must be transported through corridors, their length should be compatible with maneuvering spaces, especially around corners.

Erection tolerances should be taken into consideration in detailing structural members for fabrication. This is more of a problem in existing buildings into which steel sections are being installed. In these circumstances, a detailed survey of the building should provide the necessary dimensional accuracy. Designers/Steel detailers also should be aware that erection tolerances for various materials (other than steel) are different.

In the connection of steel to other materials, it is likely that fin-type connections will pose less of a handling problem than end-plate type connections.

It should be possible vertically to lift members that are to be installed vertically.

August, 2013

1.4.6 DESIGN TO REDUCE HAZARDS ASSOCIATED WITH TEMPORARY WORK PLATFORMS AND OTHER EQUIPMENT

Temporary work platforms must be stabilized. Designers (Detailers) should consider the provision of attaching structural members to the temporary work platforms. For example:

- a) Cladding side rails could be designed with scaffold ties, to carry the lateral loads that might be applied;
- b) Eave members should be designed to carry lateral loads imposed by the future attachment of mobile towers;
- c) Profiled steel forms and supporting steel beams should be designed to carry the concentrated leg loads that could be applied by a mobile tower;

The ability of structural members to support the fall-arrest forces by fall-arrest equipment should be verified. Structural members that are not designed for fall-arrest forces should be clearly labeled with warnings.

In order to assist a contractor to detail temporary supports, designers should provide sufficient information to ensure that a contractor has a clear understanding of the needed stability.

On multi-story buildings, much of the steelwork is erected with aerial lift equipment. Therefore, designers should consider the provision of space around the building perimeter, to accommodate such equipment.

In addition to design to make steel erection safer, designers should consider minimizing maintenance work in order to reduce the exposure of workers to health and safety hazards when performing maintenance work after the completion of construction.

End of Section

August, 2013

2. MANAGEMENT OF HAZARDS DURING MAINTENANCE PHASE

Falls from height are a major cause of work-related injuries and fatalities. Engineers, architects, designers, detailers, and planners are responsible for designing safe buildings, facilities, structures and equipment. They should strive to eliminate, minimize or prevent the hazards of falling at work places. Post-construction, the facility should protect personnel during normal work operations and should help maintenance personnel to conduct their work safely and without exposure to fall hazards.

FALL PREVENTION PHILOSOPHY FOR DESIGNING NEW BUILDINGS AND FACILITIES:

New buildings, facilities, or structures should be designed to the extent possible to eliminate the need to work at heights. When fall hazards cannot be eliminated or prevented, designers should provide alternative remedies such as installation of anchorage points.

Any location or part of a building, structure, facility or equipment will eventually require maintenance, remodeling, modification or replacement work. Engineers and architects should consider these factors in the design of new buildings.

2.1 FACILITATION OF FUTURE MAINTENANCE WORK

Designers should take into consideration future maintenance of the proposed building or facility, because they are in a strong position to eliminate and/or minimize the requirement to work at height during maintenance operations. For example, designers could:

- a) Ensure that any equipment requiring maintenance work is not located at height (e.g., on roofs with unprotected sides or edges);
- b) Specify high durability materials;
- c) Locate system/process pipe-work at ground level where practical;
- d) Avoid locating high maintenance items above stairwells and other deep recesses;
- e) For cleaning/washing, specify reversible windows above the first floor. Where this is not appropriate, ensure that provisions for access equipment are incorporated at the design stage.

The designer should apply the principles of prevention to assure that, where reasonably practical, the hazard of working at height is eliminated, removed, minimized, or finally controlled.

2.2 HAZARDS OF MAINTENANCE WORK ON ROOFS

The benefits of eliminating, or at least minimizing, the need for personnel to access and perform work on roofs is not restricted to protecting personnel from falls; although that is a major one. Other benefits include the easing of frequent maintenance by locating equipment at grade level; the elimination of foot-traffic or equipment-induced damage to roofing materials;

August, 2013

and reduction of the time required for access to equipment. It should be unnecessary to perform a cost-benefit analysis, in most cases, to illustrate the truth of these statements.

2.2.1 BACKGROUND INFORMATION ON ROOFS

Even non-fragile assemblies can be made fragile if the wrong type of material is specified. Therefore, pay careful attention to the environment in which the building is being erected. Known harsh environments include:

- a) Coastal areas, which are highly corrosive;
- b) Industrially-polluted areas, which contain airborne agents of deterioration;
- c) Industrial processes which release harmful agents;
- d) Areas of intense solar exposure, snow or ice loading, and rain ponding. Each of these environments exists in locales of various Navy installations.

With respect to maintenance, there are three basic types of roofs:

- a) **Low maintenance roofs**, which require very infrequent access or simple du-pitched roofs requiring maintenance that can be done only from ladders or aerial work platforms;
- b) **Medium maintenance roofs**, which require regular access for maintenance but only by experienced roof workers;
- c) **High-maintenance roofs**, which require frequent access for maintenance (e.g., roofs with penetrations for machinery exhausts stacks, etc).

Manufacturers' recommendations for compatible components in non-fragile assemblies should not be changed without consultation with the manufacturers.

2.2.2 DESIGN TO MINIMIZE THE NEED FOR ACCESS AND WORK ON ROOFS

This can be achieved either by minimizing the number of items requiring maintenance on a roof or minimizing the number of times people have to go on a roof, for example by:

- a) Routing vent stacks through the building side instead of the roof;
- b) Combining exhausts flues into a single vent enclosure;
- c) Assure that process by-products are effectively removed and discharged high enough above the roof to allow effective dissipation;
- d) Avoid specification of materials for which the manufacturer's warranty requires annual inspections;
- e) Optimize the number and position of roof-lights, taking into consideration the requirements for providing natural light;

August, 2013

Note: Roof-lights will require periodic cleaning to maintain correct light levels within a building.

- f) Position gutters so that cleaning can be carried out using either articulated boom lifts, or from other designated means of safe access.

The resealing of joints is a common reason for the presence of personnel on roofs. Therefore, specify durable seals and details at penetration points and flashings, to minimize the need for such repetitive maintenance.

Robust structural details for areas of the roof exposed to high wind suction should ensure that damage is minimized during predictable windstorms, to minimize the need for maintenance after such storms.

2.2.3 MINIMIZE THE RISK OF FALLING FROM UNGUARDED EDGES

Where it is not possible to eliminate the need for roof access for maintenance, items that need maintenance should be located at least:

- a) 6 feet away from skylights;
- b) 15 feet away from the edges of roofs to make it unnecessary for people to work close to the edge of the roof, and impossible to carry out the work from a ladder; and
- c) Skylights should not be within 6 feet of an edge.

In addition, provide dedicated walkways to access the items to be maintained, which should be:

- a) Non-fragile and slip-resistant for the life of the roof; and
- b) Provided with a hand-rail, if possible. Where this is not feasible, a horizontal lifeline to which a lanyard can be attached should be installed.

Workers also are vulnerable at gables and eaves. Where parapets are not desirable, design brackets to which temporary edge protection can be fixed. Discuss solutions with suppliers of temporary edge protection.

Where horizontal lifelines are provided, design the anchorages for the system to withstand the fall forces. If dead-weights (ballasted or free standing anchors) are the intended means of anchorage, check that the roof can support the weight of the anchor taking into consideration the friction of the roofing material. Restraint systems are preferred to fall arrest systems.

2.2.4 MINIMIZE THE RISKS OF FALLS FROM WORK AREAS

Gutters will, inevitably, require regular cleaning; therefore,

August, 2013

- a) Where possible, cove the top of gutters to prevent leaves from accumulating, such that dirt will not clog the gutters. Only rain water should enter the gutters.
- b) At eaves gutters, consider provision of a solid base around the building perimeter. Only when this is impractical should ladders be used, with provision of ladder-tying points at 6 feet on centers close under the gutter, with a hard and level base for the ladder for the full length of the gutter.
- c) Design valleys strong enough and wide enough to allow walking safely.

2.2.5 MINIMIZE THE RISK OF FALLING THROUGH ROOFS

To prevent falls through roofs, specify non-fragile assembly/materials.

Where frequent traffic on roofs is necessary (e.g., high-maintenance roofs), the pitch should not exceed 4 in 12, and dedicated access points, and walkways with hand-rails, should be provided to the work area.

Prohibit foot traffic on skylights; otherwise the surface may be damaged to the extent that it impairs light transmission. Skylight layouts should allow cleaning from clearly defined traffic areas with travel across the roof in straight lines without the necessity of walking on skylights.

Highlight the hazardous and non-walk areas by clearly visible pathways.

When incorporating skylights in the roof design, investigate the effects of weather (e.g., Will intense solar exposure change the color of the roof and the skylights?). For this reason, always specify skylights to have a non-fragile design life greater than that of the opaque area of the roof, and select an opaque color to avoid a monochromatic roof surface (Avoid the whole roof looking the same).

Where fragile assemblies are unavoidable; for such translucent assemblies, design systems for their safe cleaning and maintenance.

2.3 ADDITIONAL DESIGN CONSIDERATIONS

Preventive considerations for selective listing of design issues and examples:

- Where feasible, design roofs of buildings or facilities with minimum slope, rather than steep slopes; minimize the slope of the roof as much as possible. Of course, it may be desirable in regions with deep annual snow accumulations to have steep sloped roofs to shed the weight.
- Always incorporate edge protection (e.g., standard guardrails or 42-inch parapets) around all open sided floors or openings. Consider designing roof parapets, at least 39 inches high, to serve as permanent guardrails along the roof edge. Provision for snow load on the roof structure should be considered when designing parapets.

August, 2013



- Where the design includes installation of a fall arrest system or horizontal lifeline, always be alert to the existence of other equipment operating in the same area (e.g., interference between the use of a fall arrest system or horizontal lifeline with crane operations, such as inside hangars or other buildings).
- In the design of “flat” roofs, incorporate guardrails or parapets 42” ± 3” in height, around the perimeter.
- Locate equipment (e.g., HVAC) away from the edge of the roof, or provide standard guardrails around it. Roof vents, mechanical equipment, and communications equipment should be located at least 15 feet away from the roof edge. Although the distance alone is ineffective to protect personnel from unprotected roof edge, the 15-foot distance reduces the risk of a fall during equipment maintenance. Specify permanent guardrails when equipment must be closer to the roof edge.



- Use luminaires that can be replaced or maintained without exposing the personnel to the hazard of fall. As an example: in a gymnasium, use luminaires that can be lowered to the ground for changing lamps; or provide catwalk or platform to access such fixtures.
- Where windows must be operable, consider inward operating sash above second floor, so that window washing can be performed from the inside of the facility.

August, 2013

- Locate water valves, meters and other equipment and instrumentation at locations where the employee can perform necessary service without being exposed to a fall hazard.
- Where the design of buildings and facilities does not allow the use of conventional methods of fall prevention (such as the use of guardrails or other methods) design or select anchor points to withstand a force of 5,000 pounds per person, at any location with the potential of a fall from height.
- Stairs are preferable to ladders for elevation changes of 20 feet or greater.
- Always provide safe access to service equipment, instrumentation and other amenities within the building or facility.
- Design guardrails or specify covers for utility holes, even if only a few feet deep. A fall into a shallow utility hole such as those for steam or electrical lines might expose a person to other hazards such as scalds or electrocution.
- Plan on providing fall-prevention/control methods including safe access of future maintenance for any equipment, fixture, or part of a building or facility.



- Study maintenance procedures, work practices, and building and facility operations, to minimize the potential for falls by maintenance personnel.
- Provide safe access and egress to every location inside or outside of buildings or facilities.
- Understand the governing safety regulations and standards.
- In addition to design knowledge, the designer should be familiar with construction operations for a facility, and have the knowledge of the logistical operations during occupancy and any maintenance required afterwards.
- Minimize the width of parapets or short walls, or provide steeply sloped cap flashing. Some occupants of buildings have a tendency to sit on wide parapets; thereby exposing themselves to fall hazard.

August, 2013

- In the selection of fixtures, equipment, or other items to be installed on roofs, such as projectors, flagpoles, or surveillance cameras, always keep in mind maintenance requirements of such equipment or fixtures. As an example, install cameras or luminaires on tracks that can be pulled away from the edge of the roof for maintenance or service.
- Understand and identify the delivery of material or equipment procedures during construction operations. This will help in siting the building and access roads for vehicles or equipment to deliver such material safely.
- Try to eliminate any blind spots in the design.
- All hatches and openings shall be protected either by a cover or guardrail and the access ladder shall extend above the hatch. Specify the roof hatch safety system as soon as possible. The new hatches can provide for a standing access either out onto the roof or into the opening which fits the human condition and walking posture in work situations such as access to and from roofs. Existing hatches can be retrofitted in the same way. Provide guardrails around the hatch with a swing gate, or provide horizontal grab bars.



August, 2013

- Provide adequate lighting for maintenance work within a building at locations near or within close proximity of a fall hazard.
- Provide fall protection where an exposure exists for falling into water (e.g., working from a pier).
- In the design of elevated pier lighting standards, place any needed utility covers on the inside (safer location, so that the person performing maintenance service on the pole will not be exposed to a fall hazard).
- For skylights, either incorporate guardrails around the perimeter, or build the skylight at least 42 inches above the roof level.



- If needed, specify permanent roof anchors to provide convenient tie-off points for work near the edge of the roof.



August, 2013

- Specify roof materials that do not require frequent inspections.
- Locate gutters such that they can be cleaned using articulating lifts, or in other safe access areas.
- Specify durable seals at roof penetrations to minimize the need for maintenance.
- For fixed roof-access ladders attached to the side of building, specify a ladder-climbing system instead of a cage. Cages are allowed by OSHA, but protect no one from falling. Even if a ladder-climbing device is used inside a cage, rescue of a person inside a cage will be very difficult.
- In hangars, where horizontal lifelines (HLLs) are used as the fall protection solution for aircraft maintenance, make sure that there will be no interference between the crane envelope inside the hangar and the HLL system. The cranes usually are 30 to 40 feet above the working level. Additionally, incorporate a Power Tagline System to bring the snaphook of the self retracting lanyard (which is attached to the HLL) to the working level.



Power Tagline System

- For safer maintenance work, service runs could be designed for access from the floor above.

End of Section

August, 2013

APPENDIX F

Fall Protection Training Course Syllabus

For Competent Persons

Day 1

Course Introduction

- **Course Objective**
- **Safety Briefings**
- **Instructors, Students introduction**
- **Fall Mishap Statistics for Navy, Industry and construction**
- **Applicable trigger heights (When Fall Protection is required?)**
- **Examples of fall related hazards**
- **Various types of falls (From roofs/ladders/etc.)**

Regulations, Standards and Instructions

- **Applicability**
- **OPNAVINST 5100.23 Series, FP program requirements**
- **NAVMC DIR 5100.8 Chapter 18, FP Program**
- **Navy Fall Protection Guide for Ashore Facilities**
- **USACE EM 385-1-1, FP program requirements**
- **29 CFR 1910, 1926, 1915, 1918 and 1960 Standards**
- **29 CFR 1910 OSHA Notices of proposed Rulemaking (May 2010)**
- **American National Standards Institute, ANSI Z359 Fall Protection Code/Standards**
- **FAR Clause 52.236-13**
- **Similarities and Differences between various standards**

Roles and Responsibilities

- **Program Manager, Qualified person, Competent person and End Users (Authorized Persons)**
 - **Definitions in General Industry vs. Construction standards and ANSI Z359 FP Code**
 - **Comparison of duties/responsibilities and required skills/qualifications**

Hierarchy of Fall Hazard Controls

August, 2013

- **Preferred Order of control measures (Navy)**
 - Elimination
 - Prevention
 - Engineering controls (Design change or using different techniques or equipment such as movable or stationary work platforms)
 - Administrative controls including examples
 - Personal protective systems and equipment
- **Comparison between Navy, EM 385 and ANSI hierarchy of fall hazard controls**

Elimination of Fall Hazards

- **Best practices of Hazard elimination**
- **Examples and exercise of hazard elimination**

(The instructor is required to provide examples of best practices and considerations for eliminating fall hazards. The students shall be required to perform an exercise on how to eliminate the fall hazard.)

Prevention systems (Traditional/Conventional Fall Protection Systems (Passive Systems))

- **Definitions and requirements for:**
 - **Guardrails(requirements, strength, minimum material of construction and examples)**
 - **Covers and Barricades**
 - **Safety nets**
 - **Stair rails and handrails**
- **Applicable regulations, Standards and instructions**
- **Examples of prevention/conventional systems**
- **Prevention System Exercise**

(The instructor shall show a variety of slides/photos of prevention systems. The students will be asked to identify requirements and/or deficiencies.)

Aerial Lift Equipment, Work Platforms, Staging/scaffolds

- **Definitions/application/requirements**
- **Applicable regulations and standards**
- **Hazards associated with the use and or misuse of Supported, Self Supported and Suspended Scaffolds**
- **FP requirements for AWP/Scaffolds**

August, 2013

Fall Arrest System

- **Definitions**
- **Components of the system**
 - **Anchorage system**
 - **Connecting means**
 - **Body support**
- **Applicable regulations/standards/requirements**
- **Verification and certification testing requirements of the equipment**

Anchorage System (Anchorages and Anchorage Connectors)

- **Definitions/Applications**
- **Maximum arresting force/impact forces/requirements for: FA positioning and restraint**
- **Engineered vs. improvised anchorages**
- **Applicable regulations/Standards**
- **Certified vs. non certified anchorages**
- **How to identify safe anchorages and tie-off points for various systems (Non Certified anchorages)**
- **Examples of unsafe anchorages**
- **Compatibility between anchorages and anchorage connectors**
- **Swing fall hazards**
- **Demonstration of various anchorage connectors and tie off techniques**

Day 2

Continue Anchorage System

- **Workshop**

(The instructor is required to demonstrate variety of anchorage connectors, including photos/slides on how to identify safe anchorages and the method for attaching anchorage connectors to the anchorage them to anchorages.)

Connecting Means (Snaphooks, Carabiners and other connectors)

- **Definition/application**
- **Snaphooks and Carabiners (Types, applicability, Compatibility and misuse)**
- **Hazards associated with various connectors (roll-out/forced roll-out,**

August, 2013

- **Regulations and standards/requirements**
- **Proper use of and examples**
- **Navy prohibited use of snaphooks and carabiners meeting ANSI Z359.1 (1992, R1999)**
- **Exercise and Demonstration of equipment**

(The instructor shall show variety of snaphooks, carabiners and other connectors including use and misuse examples and the students will be asked to identify requirements.)

Connecting Means (Lanyards and Energy Absorbers)

- **Definitions/Applications**
- **Various types of lanyards (FA, Positioning, Restraint)**
- **Proper use and examples of lanyards and energy absorbers**
- **Requirements for 6 ft and 12 ft free fall energy absorbers (single leg or Y-lanyard)**
- **Hazards associated w/energy absorbers (Weather, type, increased fall distances, location/rigging and safe practices)**
- **Applicability of the standards**
- **Correct installation techniques**
- **Hazards and warnings associated with the use of Y- lanyards**
- **Exercise and demonstration on the use of various equipment**

(The instructor will demonstrate various energy absorbing lanyards and the students will be asked to identify requirements and proper usage.)

Connecting Means (Fall Arresters)

- **Definitions/Applications**
- **Proper use and examples of site specific energy absorbers**
- **Hazards associated w/fall arresters (Type, fall distances, location/rigging and safe practices)**
- **Applicability of the standards**
- **Exercise and demonstration of equipment**

(The instructor shall demonstrate various fall arresters and the students will be asked to identify requirements and proper usage.)

Self Retracting Devices (SRDs)

- **Definition/Application**
- **Proper use including examples of various SRDs**

August, 2013

- **Various SRDs used in horizontal and vertical applications**
- **Inspection requirements of SRDs Hazards associated with SRDs Factory authorized Inspections**
- **Applicable regulations/Standards/Requirements**
- **SRD exercise and demonstration of various types and classes of SRDs**

(The instructor will demonstrate various SRDs and the students will be asked to identify requirements and how to inspect the equipment.)

Body Holding Devices

- **Definition/Application**
- **Types of body holding devices (full body harness, body belts, sit harness, etc.)**
- **Hazards associated /body holding devices suspension hazards and misuse**
- **Donning and doffing of the equipment**
- **Prohibited uses of body belts and sit harnesses**
- **Proper use and examples of site specific body holding devices**
- **Applicable regulations/Standards/requirements**
- **D-ring locations on the full body harness including uses**
- **Capacity range of the equipment including overweight and underweight users**

Hands-On and Practical Demonstrations

- **Workshop (Attendees use various FP equipment)**
- **Exercise and Demonstration of the equipment**

(The instructor will demonstrate various types of harnesses on how to connect a complete personal fall arrest system to anchorages using various scenarios. Each student shall demonstrate how to don the harness safely. The students shall also be suspended from a tripod wearing the harness. While suspended, the students should also use suspension straps to increase suspension time.)

Drop Test Demonstration

- **How the body reacts to fall arrest forces**
- **Articulating manikin demonstration**
- **Variety of drop tests**

August, 2013

(The instructor will show a video of various drop tests of manikins wearing a harness and various lanyards.)

Day 3

Single Anchor Vertical Lifelines

- **Definitions/Application**
- **Proper use of the equipment and examples of various applications**
- **Hazards associated with misuse of the system/equipment**
- **Applicable regulations and standards**
- **Single anchor vertical lifeline exercise**

(The instructor will show video/slides/photos of vertical lifeline and associated equipment used in the process.)

Review and exam #1

Horizontal Lifelines

- **Definition/Application**
- **Impact of fall forces**
- **Proper use of the system**
- **Critical elements of the system**
- **Factors affecting design of the system (# of workers, span length, intermediate anchors, material of components, sag and tensioning of the line, clearance)**
- **Need to be engineered system, designed and used under the supervision of a qualified person**
- **Roles of CP and QP/Professional Engineer during use, assembly and inspection of the system and selection, design, use and certification of HLL anchorages**
- **Applicable regulations and standards**
- **HLL exercise**

(The instructor shall show video/slides/photos on how to install, use and inspect HLLs. The instructor shall also demonstrate some of the components of the system.)

Raising & Lowering Devices

- **Definition/Application**
- **Various types of raising/lowering devices**

August, 2013

- **Proper use and operation of the system**
- **Hazards associated with the system**
- **Raising/lowering devices exercise**

(The exercise addresses various devices including video and slides)

Positioning System

- **Definition/application**
- **Various types of devices**
- **Application, uses and proper operation of the devices**
- **Hazards associated with and misuse of the system (hooking, unhooking and fall distances)**
- **Applicable regulations/standards/requirements**
- **Work positioning exercise and demonstration**

(The students will be required to use equipment to be tied off to a vertical surface at heights attached to fixed ladder.)

Restraint system

- **Definition**
- **Examples of various uses of the system**
- **Proper use of the equipment**
- **Hazards associated with the use of the system**
- **Applicable regulations and standards**
- **Exercise and practical demonstration**

(The instructor will demonstrate how to use the system and the students will be required to assemble safe system using the equipment.)

Inspection Care & Maintenance of Fall Protection Equipment

- **Type of inspection**
- **Daily and inspection (prior to each use)**
- **Equipment Markings and Labels**
- **Annual/Semi-annual (by a competent person with documentation)**
- **Re-certification (by the manufacturer/qualified person)**
- **Equipment removal from service**
- **Applicable regulations/standards**

August, 2013

- **Exercise and Demonstration of equipment inspection with examples**

(The instructor will demonstrate how to inspect the equipment in detail and document the inspection. The students shall also identify defects in the equipment.)

Day 4

Climbing Ladder Fall Arrest System

- **Definition/application/requirements**
- **Types of ladder climbing devices**
 - Rigid rail
 - Rope
 - Cable
- **Proper attachment of the system and best practices**
- **Operation and uses**
- **Hazards associated w/ladder climbing devices**
- **Applicable regulations/Standards and requirements**
- **climbing ladder FA system exercise/demonstration**

(The instructor will demonstrate various climbing ladder FA devices. See also positioning system for additional exercise.)

Rescue/Assisted Rescue

- **Definition/applicability**
- **Basic rescue methods and procedures (manual descent, automatic decent control)**
- **Rescue planning (Rescue plan Development)**
- **Rescue equipment**
- **Applicable regulations/standards/requirements**
- **Rescue scenario exercise/demonstration**

(The instructor will oversee the students demonstrate of an actual rescue exercise of a fallen and arrested worker.)

Warning Line System/Designated Area/Controlled Access Zone/Monitoring System and Fall Protection Plan

- **Definition/requirements and Applications**
- **Prohibited and permitted uses**

August, 2013

- Hazards associated with using the above systems, prohibition and permitted uses
- Applicable regulations and standards

Fall Protection Problem Solving

- Workshop, students are presented with as many working at height scenarios as possible
- Students must demonstrate applied learning by solving fall hazard scenarios presented by applying hierarchy of fall protection
- Students perform Navy fall hazard analysis (per OPNAVINST 5100.23 series), erect, use and dismantle fall protection systems under the supervision of the instructor
- How to calculate free fall distance, total fall distance and clearance requirements

Day 5

Engineered System

- Specifications for engineered systems
- Testing of anchorage system
- Off the shelf vs. custom solutions
- Documentation and certification
- Recommendations for engineered system requirements

Preparation of Fall Protection & Prevention Plans (Written work Procedures per ANSI Z359.2)

- Components of the plan
- How to write fall protection & Prevention plans (Work Procedures)
- Written SOP Exercise

(The students shall develop a fall protection and prevention plan of an actual fall hazard location.)

Preparation of Fall Hazard Rescue plan

- Components of the plan
- How to develop the plan
- Written SOP Exercise

(The students shall develop a rescue plan of an actual fall hazard location.)

August, 2013

Requirements, Best Practices and Fall Hazard Issues associated with:

- **Portable ladders**
- **Fixed ladders**
- **Working over water**

Final Exam and course Conclusion

- **Written Examination**
- **Review and marking of the exam course evaluation**
- **Questions and answers**
- **Conclusion**

Note:

At the completion of the training the attendees shall be able to demonstrate their working knowledge of fall arrest equipment, procedures and requirements through hands-on and practical demonstrations.

End of Document