

Design and Analysis of Ultra Wide Band Planar Monopole Antenna

M. K. A. RAHIM, T. MASRI, H. A. MAJID, O. AYOP, F. ZUBIR
 Radio Communication Engineering Department
 Faculty of Electrical Engineering
 Universiti Teknologi Malaysia
 81310 UTM Johor Bahru, Johor
 MALAYSIA

mkamal@fke.utm.my , mthelaha@feng.unimas.my, huda_set@yahoo.com, osman@fke.utm.my,
 farid@fke.utm.my

Abstract: - A novel two layered UWB antenna is proposed and designed to resonate at the full range of UWB frequencies' spectrums from 3.1 GHz up to 10.6 GHz, well below -14.0dB reference levels of return loss. The size of the UWB antenna is small, with width of 31.0 mm and length of 25.0 mm, and the two layers of FR4 board thickness are 0.5 mm (top layer) and 1.6 mm (bottom layer). The antenna radiates omni-directionally with different intensities at different directivities within the UWB frequency spectrums. The dual layered configuration gives the antenna additional options of being integrated with additional structures in order to perform a band rejection of a certain targeted band of frequencies, if required. The UWB antenna has also been fabricated using the same dimensions on a single layer 1.6 mm thick FR4 board and it still gives similar excellent performance.

Key-Words: - UWB antenna, planar antenna, monopole antenna, omnidirectional, short range communication

1 Introduction

A modern generation short-range wireless communications technology namely the Ultra Wide Band (UWB) system, operates at an extremely wide range of frequencies from 3.1 GHz up to 10.6 GHz and allows high rate data transmission which is expected to reach above 2 Gbits/s with low power consumption. These frequency ranges as shown in Figure 1, are divided into five band groups of two or three sub bands, with each sub band, a bandwidth of 528MHz and having managed in a way that permits optimal spectrum usage.

The FCC approval of UWB for commercial use [1] has prompted industry, as well as the academia, to put significant efforts into this technology. Currently, several regulatory bodies are conducting studies to build world wide UWB regulations. The majority of the debate on UWB is centered around the question of whether it will cause harmful interference to other systems and services. Table 1 below shows the proposed usage

of the frequency spectrums for the main region in for UWB between 3.1 and 10.6 GHz. For European region, there is two band of frequency which is low frequency band is between 3.1 and 4.8 GHz while high frequency band is between 6 – 8.5 GHz. Japan region also has two band frequency which is low band frequency is between 3.4 – 4.8 GHz while the high band frequency is between 7.25 GHz and 10.25 GHz. Different region has different band of frequency band.

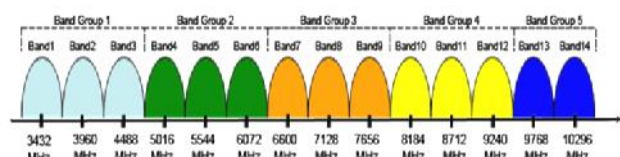

Fig. 1 The five Band Groups Spectrum allocations for UWB applications used in the WIMEDIA UWB system.

Table 1 Proposed UWB frequency spectrums in the world [2]

Region	UWB band
United States	Single band: 3.1GHz-10.6GHz
Europe	Low band: 3.1GHz-4.8GHz High band: 6GHz-8.5GHz
Japan	Low band: 3.4GHz-4.8GHz High band: 7.25GHz-10.25GHz

The FCC has mandated that the radio transmissions can legally operate at a limited transmit power of -41.3 dBm /MHz, ensuring protection of licensed services against potential interferences. Outdoor and indoor emission mask is at the same level and is lower than 10 dB outside this band to obtain better protection from other wireless services. Table 2 shows the FCC emission limits for indoor and hand-held systems.

Table 2 The FCC emission limits for indoor and hand-held systems [2].

Frequency Range (MHz)	Indoor Emission Mask (dBm/MHz)	Outdoor Emission Mask (dBm/MHz)
960-1610	-75.3	-75.3
1610-1900	-53.3	-63.3
1900-3100	-51.3	-61.3
3100-10600	-41.3	-41.3
above 10600	-51.3	-61.3

Technically, the UWB devices should not employ a fixed structure and should transmit only when sending information to an associated receiver. Physically, their antennas should be mounted on the device itself and if possible, not allowed to be placed on outdoor structures. The potential interference depends on when and where the device is used, its transmission power level, numbers of device operating, pulse repetition frequency, direction of the transmitted signal and many more. A UWB system is supposed to be used for a short range communication. Although the FCC has

allowed UWB devices to operate under mandatory emission masks as shown in Table 2 above, testing on the interference of UWB with other wireless systems should and will still continue. Given the identified bands and failure to comply with the regulations aforementioned, UWB systems could become a potential jammer for the numerous licensed services.

Antenna designers have a bountiful of UWB antennas, already proposed to be used within these range of frequencies. The antennas are known for their wide impedance bandwidth and good omnidirectional radiation patterns. Some antennas cover partially a certain band of frequencies, such as for Band Group 1 only, or for Band Group 3, 4 or 5 only, and some covers the whole range. UWB antennas that possess bandwidth covering the whole range of the stated UWB frequencies should have an extra circuitry in order to avoid collisions or filter out some band of frequencies that might cause interferences [3-6]. Alternatively, the use of antennas with band-rejected operation can relieve the requirements for the filtering electronics within the wideband devices.

2 Design consideration of UWB antenna

The design of the UWB antenna can be traced back and related to the design of a monopole antenna. Conventional monopole has a straight wire configuration against a ground plane, as illustrated in Figure 2. It is one of the most widely used antennas for wireless communication systems due to its simple structure, low cost, omnidirectional radiation patterns and ease for matching to 50 Ohm devices. Besides, it is unbalanced, thus eliminating the need for a balun, which may have a limited bandwidth [7]. The -10 dB return loss bandwidth of straight wire monopole is typically around 10 to 20%, depending on the radius-to-length ratio of the monopole.

A simple simulation has been carried out on this monopole antenna. The results are presented in Figure 3. It is noticed that the absolute bandwidth (ABW) increases as the monopole diameter is increased from 1 mm to 2.5 mm. The ABW starts to decrease again for the diameters of more than 2.5 mm. This is due to the mismatch between the radiating rod and the feed line. From this simple simulation, it indicates that a thicker radius structures will lead to a broader bandwidth and a technique to match its feed to the radiating rod is

needed. It is quite difficult to achieve this for monopole configuration, but, planar type of antenna might works. Since monopole antenna originates from dipole by removing one element and driving the remaining one against a ground plane, why not the microstrip antenna? With this objective in mind, another simple experiment is carried out.

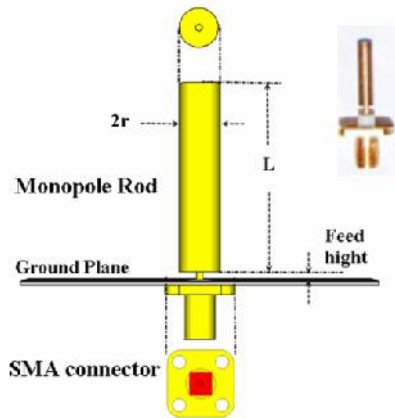

Fig. 2 A simple monopole on an infinite aluminium ground plane of size 50 mm², fed using a 50 Ohm SMA connector.

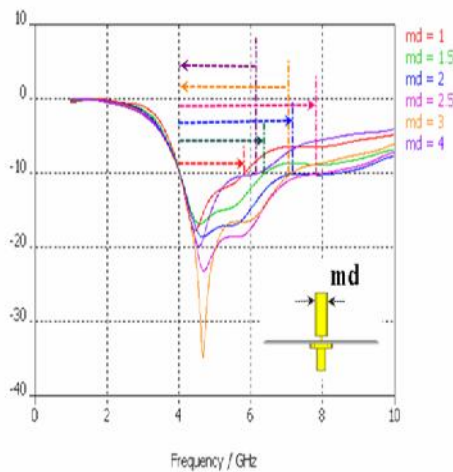

Fig. 3 Simulated return loss (S_{11}) of the monopole antenna..

At the starting point in designing the UWB antenna, the main patch is initially calculated using the pronounce formula for a rectangular microstrip antenna (MSA), at the centre frequency of the UWB spectrums of 7.85 GHz. Upon optimization, the Length is found to be 7.5 mm. Assuming this is the first harmonics from a much larger patch, usually twice the length of this patch, the width and length of the square patch antenna should then be doubled

and taken as 15.0 mm (i.e. 2* 7.5 mm) for this case. The substrate's width and length is initially set to three times the length of the patch element, i.e. about 45.0 mm², giving enough space to move the patch elements around during the modification process later on. Figure 4 (a) and (b) depicts this step.

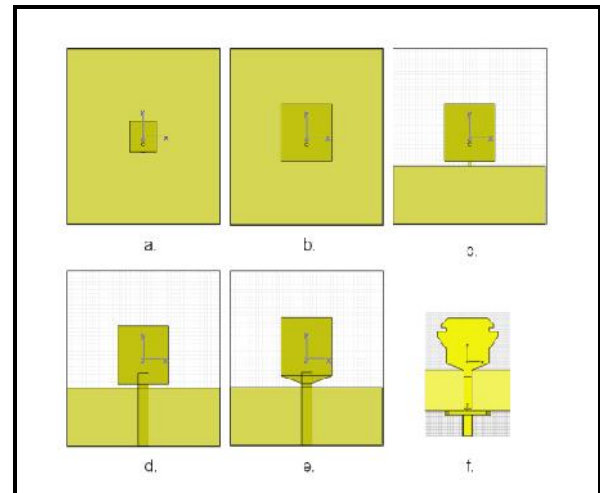

Fig. 4 The five initial steps in designing an UWB antenna (a) – (e) and (f) is the optimized UWB antenna with SMA connector.

A coaxial feed technique is initially used in step (a) to (c) as shown in figure 4. After that, the ground plane is cut to one third (15.0 mm) as depicted in Figure 4(c), to convert the MSA into a monopole antenna. 15.0 mm is chosen because through calculation at the lowest frequency of 3.1 GHz, the transmission line feeding technique introduced next has a similar length. Then, the patch and the coaxial feed are shifted up just above the ground plane. The ground plane connection to the ground section of the coaxial probe feed ~ the SMA connector as shown in Figure 4(c) is maintained by introducing a small stretch of transmission line extended from the ground plane. Then, the coaxial feed technique is changed to transmission line feed technique as this is the intention of this project. Finally, a trapezoid of length 2 mm with a chamfer of about 71.5° is introduced, connecting the edge of the lower patch element to the transmission line feed as shown in Figure 4(e).

The diagram in Figure 4(f) shows the optimized UWB antenna with an additional extra patched added on the top portion of the main patch element to fine tune the impedance bandwidth at a certain frequencies and a miniaturized substrate and ground plane size. SMA connector is also designed

and used as the port connected at the edge of the transmission lines. Figure 5 shows the simulated results for each of the steps in the designs mentioned above. The double layered substrates' height is 2.1 mm (1.6 + 0.5) mm with dielectric constant of 4.4 and Tangential Loss of 0.019.

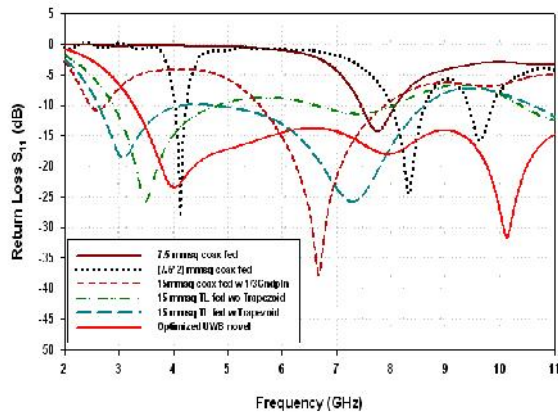

Fig. 5 The simulated results of the six antennas.

An important clue or trick to obtain an ultra-wide bandwidth antenna is by converting the patch antenna into a monopole antenna as discussed before and introducing a technique to match the feed system to the radiating patch. This is achieved by slicing the top portion of the ground plane that covers the radiating patch element to less than half and covers the transmission line section only. The return loss shown after this is done covers a wider bandwidth, starting from the actual resonance frequencies up to the first harmonics and a further tweaking and modification of the antenna's parameters is needed to improve the impedance bandwidth results.

Figure 6 shows the perspective view geometries of the novel transmission line fed Ultra Wide Band antenna. The design details consist of a two layer substrates with an air gaps of 0.035 mm thick in between them. The main radiating patch is on top of the first layer of the 25 x 31 mm² board with a thickness of 0.5 mm and is fed via a transmission line feed technique. A small gap (TL gap) is introduced so as not to short the transmission line feed to the SMA connector grounded body. The relative permittivity/dielectric constant of the FR4 substrate is set to 4.4 with a tangential loss of 0.019.

The partial ground plane is printed at the bottom of the second layer board with a thickness of 1.6 mm, with length of 12.5 mm and width of 25.0

mm. The initial length of 13.0 mm is calculated for the length of the transmission line feed (using all the parameters defined above) at the lowest UWB frequency of 3.1 GHz. The ground plane length is optimized and reduced, slightly less than the transmission line length so as to reduce the coupling effect with the trapezoid shaped patch at the top layer and to get the lowest frequency response at 3.1 GHz at the - 10 dB level. Thus, the ground patch length of 12.5 mm is obtained. The ground plane of this antenna is rectangular shaped, flat and not modified.

Two pair of extra patches is introduced at both sides of the main patch and they are noted as the 'lower extra patch' and the 'upper extra patch'. With the incorporation of these extra patches, the impedance bandwidth throughout the spectrum of the UWB antenna frequencies is well matched below -14.0 dB. The last important component is the SMA connector. It is designed according to the actual specification of the Straight Panel Jack Receptacle type (except the HEX and thread), and the dimensions are referred from [4]. It represents the real SMA connector used in the actual design. Before the simulation is conducted, the SMA connector is assured to work at an impedance of 50 Ohm for frequencies ranging from 1.0 GHz to 15.0 GHz. In practical application, the connector is not limited to SMA type only. Other type of connector with 50 Ohm impedance can be used.

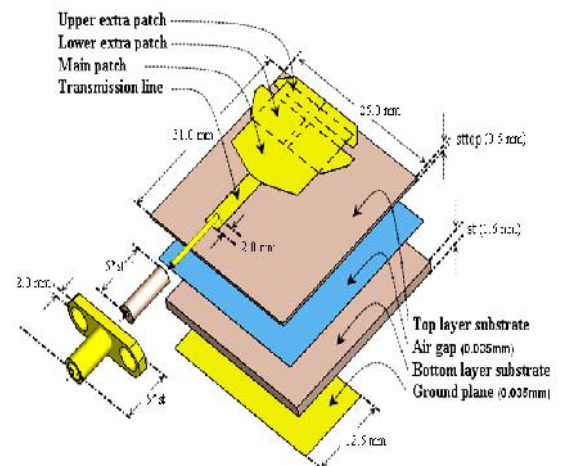
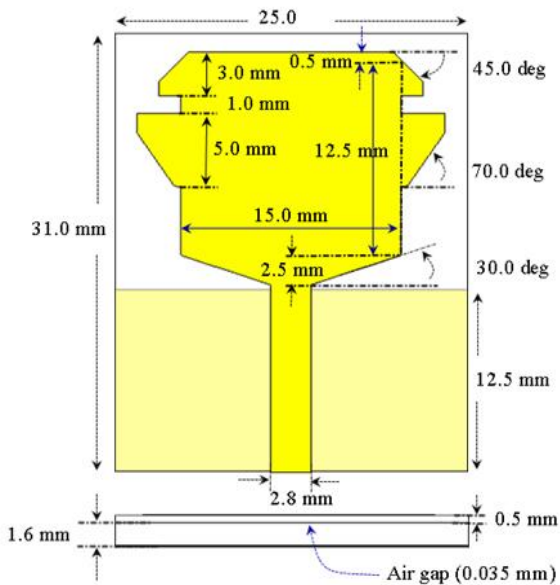

Fig. 6 The detail geometries of the novel transmission line fed Ultra Wide Band antenna

Figure 7 shows the detailed dimensions of the fabricated two-layered UWB antenna using FR4 board. Figure 7(a) shows the top view of the main radiating patch attached to its transmission line feed

and the ground plane at the back portion. The dimension of the antenna is also shown in this figure. Figure 7(b) shows the actual fabricated of the antenna.



(a)

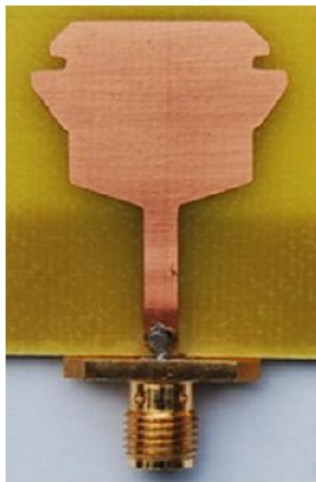

(b)

Fig. 7 (a) The detail dimensions of the UWB antenna and (b) The Fabricated Antenna with SMA connector

3 Result and Discussion

Figure 8 shows the first simulated results without the introduction of the extra patches. The substrate has been set to 30 x 30 mm². From this initial design, the current distribution at different frequencies are observed and studied. This is to identify the active area and by adding extra patches into this area, the impedance bandwidth curves could be tuned and further improved.

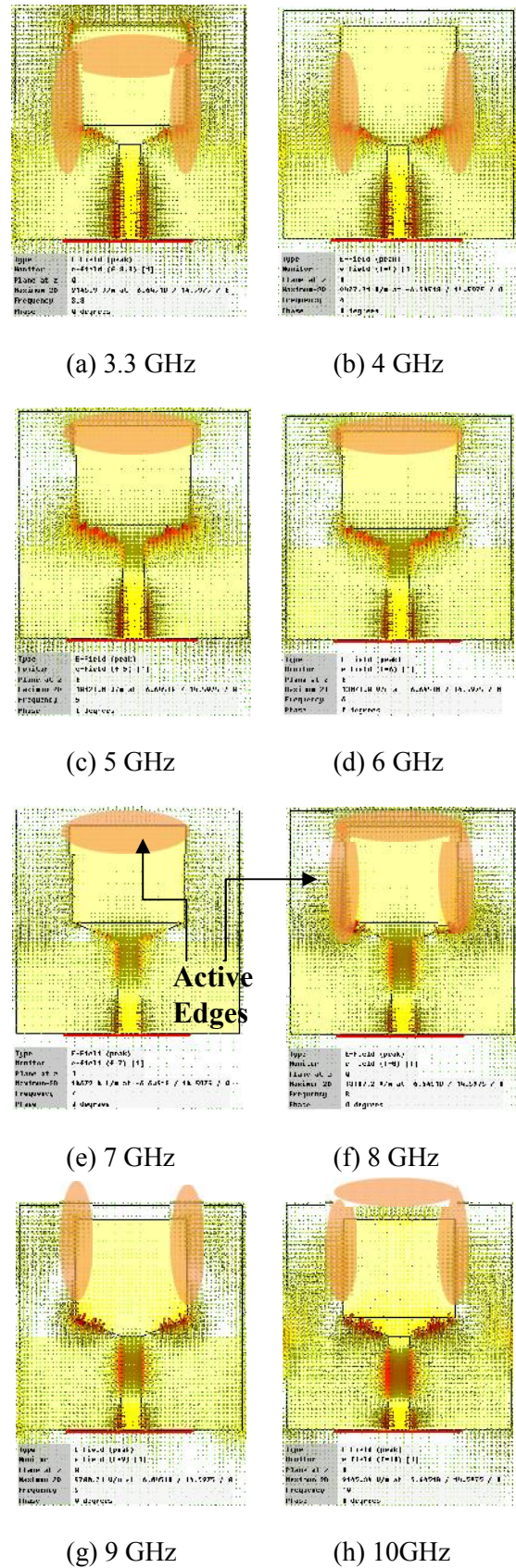

Fig. 8 The surface currents distribution at the initial design stage for the UWB antenna.

From the results plotted in Figure 8, the active areas are identified. Most of the active areas are located at the left and right edges of the main patch and some on the top section of the patch. Therefore, extra square shaped patches are introduced at these areas as shown in the figure. The upper extra patch length is shorter than the lower extra patch length, purposely for two distinct higher and lower frequencies. The distance between the two patches is set to 1.0 mm. To improve the impedance bandwidth, firstly the lower edge of the lower extra patch is chamfered to the best angle of 70° and then the upper patch is done the same to 45°. Upon doing so, it is observed that the return loss curve could be further improved and a -2.0 dB reduction was achieved at the 9.0 GHz and 10.5 GHz curves.

Then, further adjustment of the extra patches by moving them from the edge of the main patch in the outward direction gives better results as depicted in Figures 9, 10 and 11. The results in Figure 9 shows that when the upper and the lower extra patch are at the position of 1.0 mm from the edge, there exists a bump at around 7.0 GHz and it can be reduced to the best minimum value by moving the lower extra patch and the best results is when the lower extra patch is at 2.0mm from the edge of the main patch. In the process of doing so, it is also noticed that the dips at 8.5 GHz jumps up to the highest level touching the -10 dB level when the extra patch is at its maximum of 3.0 mm but at the best position, it is tuned down to -20.0 dB level. At the same time the curve at around 10.5 GHz is tuned down to its deepest dip at -35.0 dB.

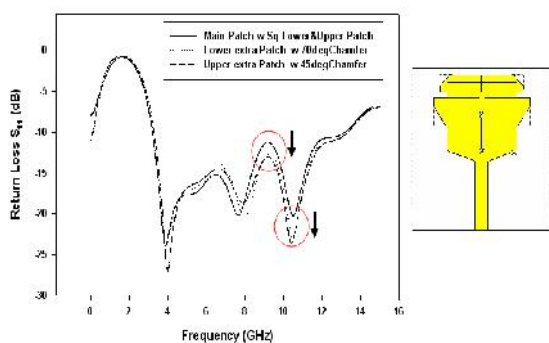

Fig. 9 The Effect of introducing the extra Lower and Upper patch with their respective angle of chamfering.

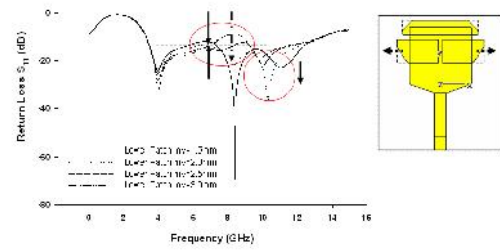

Fig. 10 Adjusting the Lower extra patch.

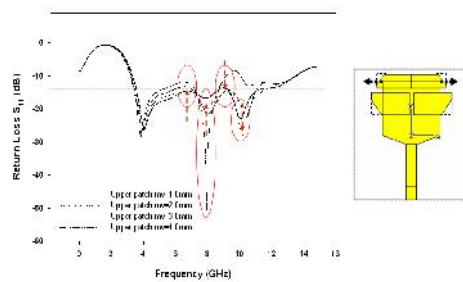

Fig. 11 Adjusting the Upper extra patch.

The final simulated and measured results are shown in Figure 12. The measured return loss covers all the UWB spectrums of frequencies from 3.1 GHz to 10.6 GHz, well below the -10.0 dB level. The simulated results show a better and larger absolute bandwidth from 3.1 GHz up to over 13.0 GHz. This is valid in simulation but in reality the measured results manage to cover up to 11.3 GHz due to the fact that FR4 board is practically suitable for frequencies below 10.0 GHz and at the higher frequencies, more losses occur.

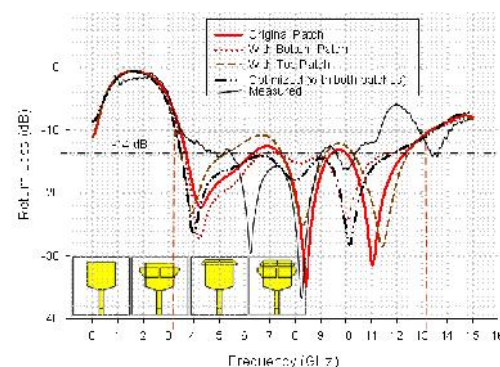

Fig. 12 The simulated return loss (dB) results, without and with the additional patches, compared to the fabricated UWB antenna.

3.1 Return Loss Result

The graphs shown in Figure 12 depict the results when the antenna is without and with the extra patches and the final optimized measured results of the UWB antenna. The two pairs of extra patches introduced at both sides of the main patch are used to improve the impedance bandwidth throughout the spectrum of the UWB antenna frequencies. By adjusting these ‘ears’ horizontally along the x axis, the curves at around 7 GHz and 10 GHz could be further reduced and adjusted well below -14.0 dB as shown in the simulated results. The measured return loss covers all the UWB spectrums of frequencies from 3.1 GHz to 10.6 GHz, well below the -10.0 dB level. The simulated results show a better and larger absolute bandwidth from 3.1 GHz up to over 13.0 GHz. This is valid in simulation but in reality the measured results manage to cover from 3.1 GHz up to 11.3 GHz due to the fact that FR4 board is practically suitable for frequencies below 10.0 GHz and at the higher frequencies, more losses occurs. The UWB antenna has also been fabricated using a single layer of 1.6 mm FR4 board and using the same dimensions given, it still gives similar performance.

3.2 Radiation Pattern Simulations

The radiation patterns of the UWB antenna differs from those of monopole antennas at the centre frequencies of the five Band Groups of spectrums allocated for UWB applications used in the WIMEDIA UWB system. Although UWB antennas can be considered as monopole antenna that’s supposed to radiate omni-directionally at all bands of frequencies, but in this study, it was found out that the antenna radiates omni-directionally with different intensities at different directivities at all the centre frequencies of band group 1 to 5.

Figures 13(a) to (e) depict the simulated radiation patterns in 3D form, for all the centre frequencies of the band group channels (band group 1 to 5) for the novel UWB antenna. The intensity and directivity of the radiation directivity seems to be more towards the -ve z direction as shown in the radiation patterns results of Figures 13 (a), and those of Figures 13(b) and 13(c) are more towards the +ve z directions. The third channel in band group 4 starts to radiate directionally upward and divided into two directions and in band group 5 as shown in figure 13 (d) and (e), it radiates in this two directions more clearly. This is expected due to the fact that the ground plane of the UWB antenna is vertically in parallel with the main radiating element. The whole metallic components i.e. the

main patch, the transmission line and the ground plane have their own role and play their parts in characterizing the radiation patterns. The dielectric substrate length (in the +ve y direction) have little effect toward this patterns.

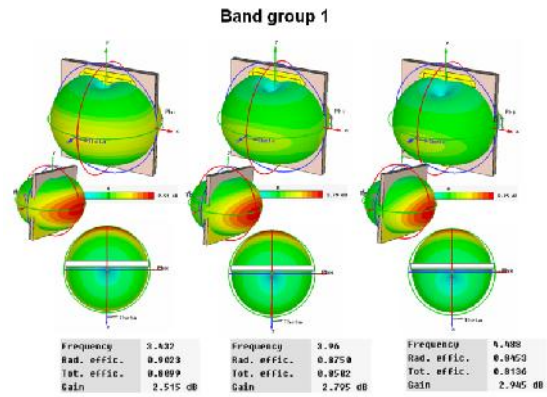

(a) Band Group 1

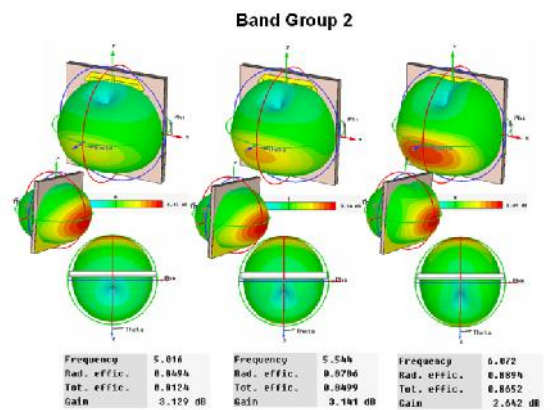

(b) Band Group 2

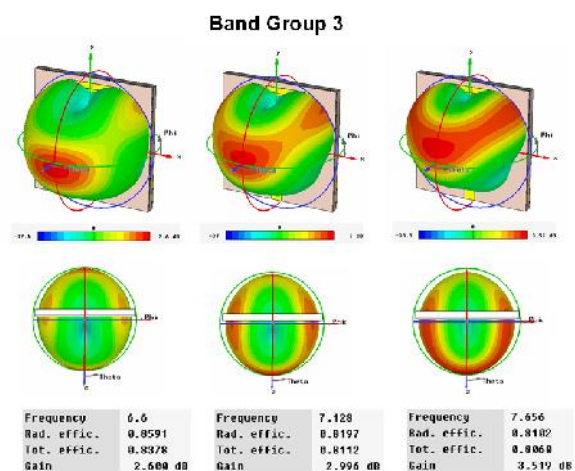

(c) Band Group 3

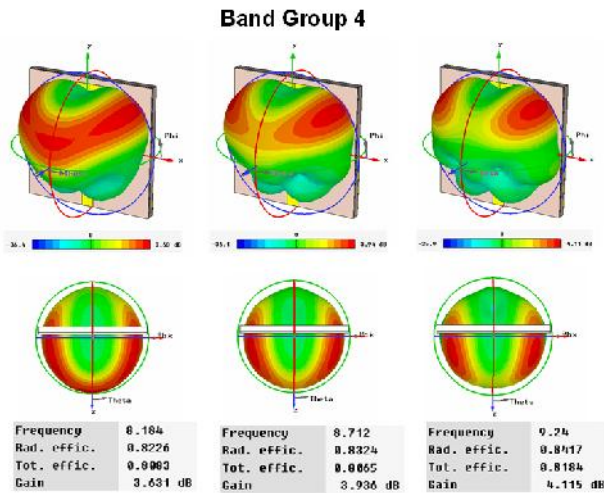

(d) Band Group 4

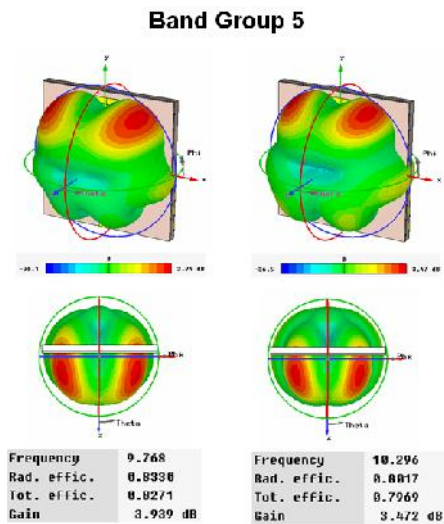

(e) Band Group 5

Fig. 13 The simulated 3D radiation patterns of the UWB antenna

3.3 Radiation Pattern measurements

At the selected frequency, the E and H radiation patterns' plane cut for the UWB antenna has been plotted and is shown in figures 14. The measured radiation pattern is at 4.5 GHz and 7 GHz. It shows that the radiation is omni directional pattern. Their directivity is more towards -ve z direction as shown by the arrows in the diagrams. These antennas are linear polarized antenna as their cross polarization axial ratio is more than -3dB.

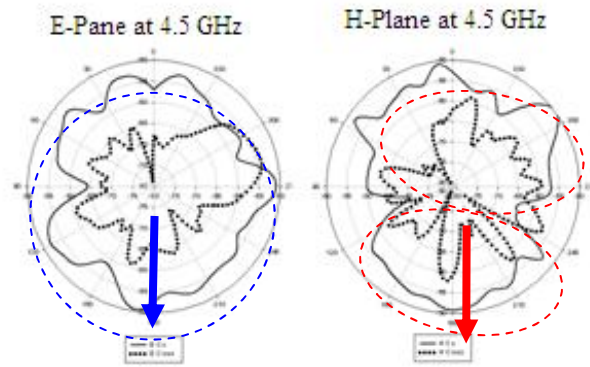

(a) Radiation pattern at 4.5 GHz

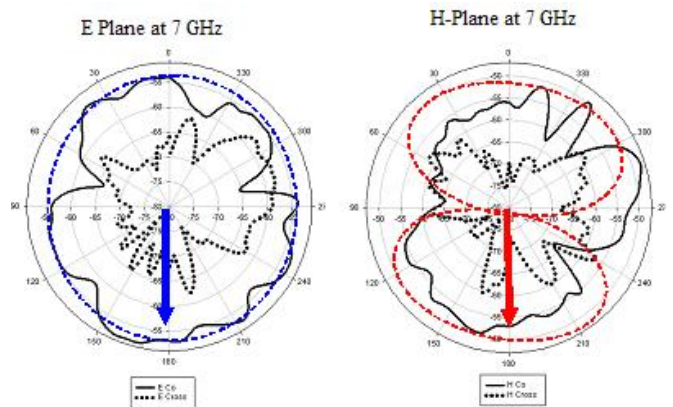

(b) Radiation pattern at 7 GHz

Fig. 14 E and H plane cuts for the UWB antenna at 4.5 GHz and 7 GHz

3.4 Antenna Gain

For the whole range of the band groups centre frequencies, the simulated radiation efficiencies and the total efficiencies of this UWB antenna is above 80%, as plotted in the graph in Figure 15. Its gain increases gradually from 2.5 dB for the first band in band group 1, up to 3.14dB of the second band of band group 2. Then it decreases a little to 2.6 dB at the first band in band group 3 and increases again up to the maximum of 4.12dB at the third band of band group 4. The last band of band group 5 has a gain of 3.47 dB. Technically speaking, this antenna works better for the higher band groups 4 and 5 and is good for the 5.8 GHz applications as its gain is low at this range. Figure 16 shows the measured gain of the UWB antenna, compared to the standard horn antenna. The gain of the standard Horn antenna gradually decreases as frequency increases. This is

due to the losses in the long cable used for the measurement. In this measurement the gain of the antenna relative to the horn antenna for band one is -15 dB. For band 2 the relative gain is -15 dB. Band 3 has a relative gain of -10 dB. It shows that this UWB antenna has a relative gain between -10 to -15 dB compared to horn antenna. For the rest of the band, the measurement is not being done due to the limitation of the signal generator that could transmit up to 8 GHz frequency only.

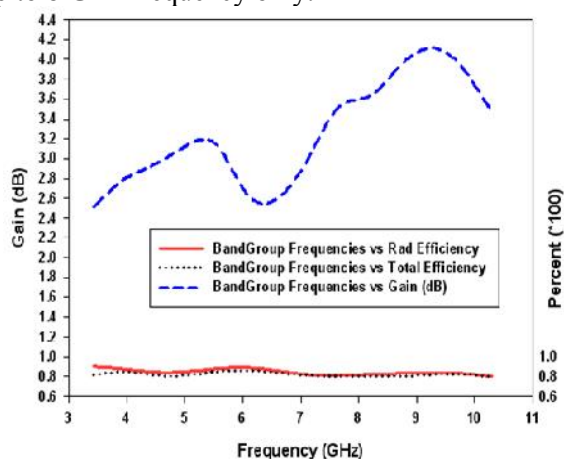

Fig. 15 Simulated Gain (dB), total efficiency and Radiation efficiency for the radiation patterns of Figures 13 (a)-(e) structures

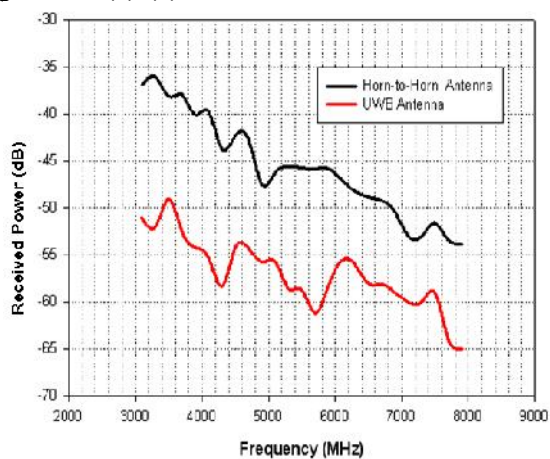

Fig. 16 The measured gain of the UWB antenna, relative to the standard horn antenna

4 Conclusion

Models of the UWB antenna has been successfully developed and constructed on an inexpensive Fire Retardant-4 (FR4) board, using wet etching techniques. This novel UWB antenna is designed to resonate at the full range of the UWB frequencies and additionally, it is ready to be integrated with additional structures in order to perform the band rejection of certain targeted band of frequencies, if

required. Nonetheless, upon achieving the objectives, further experiments on rejecting and filtering a certain band of frequencies could be carried out by introducing extra structures under the transmission lines between the two substrates layers, if needed. The UWB antenna has a bandwidth between 3 and 11 GHz with respect to -14 dB return loss. The measured gain relative to horn antenna for the UWB antenna is between -10 to -15 dBh. This measurement has been done in the frequency range of 3 GHz to 8 GHz. The simulated antenna gain of this antenna is between 2.4 dBi and 4 dBi. The antenna is in omni directional pattern with a linear polarization and cross polar isolation of more than 10 dB from the maximum gain. The different intensities of the antenna can be found at different directives within the UWB spectrum frequencies.

Acknowledgement

The authors thank to the Ministry of Science, Technology and Innovation (MOSTI) of Malaysia, Research Management Center (RMC), UTM and the Faculty of Electrical Engineering for supporting this research.

References:

- [1] Kim, J., T. Yoon, J. Kim, and J. Choi, Design of an ultra wideband printed monopole antenna using FDTD and genetic algorithm," *IEEE Microwave and Wireless Components Letters*, Vol. 15, No. 6, pp. 395-397, June 2005
- [2] Jianxin Liang, 'Antenna Study and Design for Ultra Wideband Communication Applications,' PhD Thesis, Department of Electronic Engineering, Queen Mary, University of London, United Kingdom. July 2006
- [3] J.Y.Deng, Y.Z.Yin, J.Ma and Q.Z.Liu, "Compact Ultra Wideband antenna with dual band notched characteristic", *Journal of Electromagnetic Waves and Application*, Vol. 23, 2009, pp. 109 – 116
- [4] D.-Z Kim, J.-W.Yu, "Wide-band Planar Monopole Antenna with Triple band Notched Slots", *Journal of Electromagnetic Waves and Application*, Vol. 23, 2009, pp. 117 – 128
- [5] X.Li, L.Yang, S.-X Gong and Y.-J. Yang, "A Novel Tri- band notched Monopole Antenna", *Journal of Electromagnetic Waves and Application*, Vol. 23, 2009, pp 139 – 147
- [6] Jaehoon Choi, Seokjin Hong, and Uisheon Kim, "The Design of an UWB Antenna with Notch Characteristic," *PIERS Online*, Vol. 3, No. 7, 2007, pp. 987 - 990

- [7] M. J. Ammann and Zhi Ning Chen, "Wideband Monopole Antennas for Multi-Band Wireless Systems", *IEEE Antennas and Propagation Magazine*, vol. 45, no. 2, 2003, pp. 146-150
- [8] S.D. Moon, and H.Y. Hwang, "Improvement in band rejection characteristics of a wideband antenna using resonant slots" *Microwave Journal*, Vol. 50, No 10, 2007, pp. 116-124
- [9] J. Wang, X. Sun, K. Okada, "UWB Circular Monopole Omni directional Antenna with a Slot for Radiation Pattern Improvement" *International Conference on Ultra Wideband*, Marina Mandrin Hotel, Singapore, 2007
- [10] S. Hong, H. Lee, S. Lee and J. Choi, "A compact printed antenna with band-stop characteristic for UWB application" *Progress in Electromagnetic Research Symposium 2007*, 2007, pp. 188-191
- [11] FCC First Report and Order and adopted the rules for Part 15 operation of UWB devices on February 14th, 2002
- [12] Subminiature Coaxial Connectors and Cable Assemblies, Applied Engineering Products (AEP) Edition III, 1992



Mohamad Kamal A Rahim received the B Eng degree in Electrical and Electronic Engineering from University of Strathclyde, UK in 1987. He obtained his Master Engineering from University of New South Wales Australia in 1992. He graduated his PhD in 2003 from

University of Birmingham U.K. in the field of Wideband Active Antenna. From 1992 to 1999, he was a lecturer at the Faculty of Electrical Engineering, Universiti Teknologi Malaysia. From 2005 to 2007, he was a senior lecturer at the Department of Radio Communication Engineering, Faculty of Electrical Engineering Universiti Teknologi Malaysia. He is now an Associate Professor at Universiti Teknologi Malaysia. His research interest includes the areas of design of active and passive antennas, dielectric resonator antennas, microstrip antennas, reflectarray antennas Electromagnetic band gap (EBG), artificial magnetic conductors (AMC), lefthanded metamaterial (LHM) and computer aided design for antennas. He has published over 100 Journal articles and conferences paper. Dr. Mohamad Kamal is a senior member of IEEE since 2007. He is a member of Antennas and Propagation Society and Microwave Theory and Technique



Thelaha Masri received the B. Eng. degree in Telecommunication Engineering in 2003 and Master Engineering in Electrical in 2005 from Universiti Malaysia Sarawak. He obtained his PhD from Universiti Teknologi Malaysia in 2009.

Currently he is working as a senior lecturer at UNIMAS Sarawak His research interest are antenna designed, electromagnetic band gap structure, left handed metamaterial, planar antenna and ultra wide band antenna.



Huda A Majid received the B.Eng degree in Telecommunication Eng. in 2007 and Master Engineering in Electrical in 2010 from Universiti Teknologi Malaysia. Currently he is a PhD Research student at Faculty of Electrical

Engineering, Universiti Teknologi Malaysia. His research interest are left handed metamaterial, planar antenna, textile antenna and antenna for cognitive radio system



Osman Ayop received the B. Eng degree in Telecommunication Engineering in 2007 and Master Engineering in Electrical in 2010 from Universiti Teknologi Malaysia. Currently he is working as a tutor

at Universiti Teknologi Malaysia Johor Bahru His research interest are antenna designed, electromagnetic band gap, electromagnetic compatibility and frequency selective surfaces



Farid Zubir received the B. Eng degree in Telecommunication Engineering in 2008 and Master Engineering in Electrical in 2010 from Universiti Teknologi Malaysia. Currently, he is a tutor at Universiti Teknologi Malaysia, Johor Bahru. His current research

interests are in the area of Microwave Antenna Design including Antenna array, Reflector Antenna, Phased-array, Microstrip Reflectarray Antenna as well as Linearization Technique for amplifier circuit.