

# Design and Fabrication of Paper Shredder Machine

**Dr. Fauzia Siddiqui<sup>1</sup>, Harshad Patil<sup>2</sup>, Swapnil Raut<sup>3</sup>, Omkar Wadake<sup>4</sup>, Swapnil Tandel<sup>5</sup>**

<sup>1</sup>HOD, Mechanical Engg Dept, SCOE, Kharghar, Navi Mumbai, India, fauzia.hoda@gmail.com

<sup>2</sup>Student, SCOE, Kharghar, Navi Mumbai, Maharashtra, India, hbpatil17@gmail.com

<sup>3</sup>Student, SCOE, Kharghar, Navi Mumbai, Maharashtra, India, swap1994raut@gmail.com

<sup>4</sup>Student, SCOE, Kharghar, Navi Mumbai, Maharashtra, India, rajwadake1994@gmail.com

<sup>5</sup>Student, SCOE, Kharghar, Navi Mumbai, Maharashtra, India, swapniltandel109@gmail.com

**Abstract--** This paper deals with a detailed study & design procedure of a paper shredder machine. A detailed study of various parts of shredder machine like stand (frame), transmission system and cutting system are made and designed separately. The first part deals with the study of cutting system of a shredder machine i.e. types of blades, different profiles, its dimensions, its alignment, advantages and disadvantages of different types of blades. The second part includes problem definition, objectives, procedure of design with the detailed design of each component of the cutting and transmission system i.e. designing a blade and making certain modifications in it and the frame. The third and last part deals with the design of 3D model of various parts on Dassult Systems "SOLIDWORKS 2014" and its motion study and the analysis of the stand in ANSYS 15.

**Keywords-** SolidWorks2014, ANSYS15, Shredder Machine.

## INTRODUCTION

A paper shredder is a mechanical device used to cut paper into chad, typically either strips or fine particles. Government organizations, businesses, and private individuals use shredders to destroy private, confidential, or otherwise sensitive documents. Privacy experts often recommend that individuals shred bills, tax documents, credit card and bank account statements, and other items which could be used by thieves to commit fraud or identity theft.

### Types of paper cut:-

i. Strip-cut shredders: - These rotating knives to cut narrow strips as long as the original sheet of paper. Such strips can be reassembled by a determined and patient

investigator or adversary, as the product (the destroyed information) of this type of shredder is the least randomized.

ii. Cross-cut or confetti-cut shredders: - They use two contra-rotating drums to cut rectangular, parallelogram, or lozenge (diamond-shaped) shreds.

iii. Particle-cut shredders: - They create tiny square or circular pieces.

iv. Cardboard shredders: -They are designed specifically to shred corrugated material into either strips or a mesh pallet.

v. Pierce-and-tear shredders: -They have rotating blades that pierce the paper and then tear it apart.

vi. Grinders: -They have a rotating shaft with cutting blades that grind the paper until it is small enough to fall through a screen.

vii. Disintegrators and granulators: -They repeatedly cut the paper at random until the particles are small enough to pass through a mesh.

### Objectives:-

1. To formulate a study on different elements of the shredder machine like the blades, frame, transmission system, etc.

2. To design a machine which will produce less noise and vibrations.

3. To construct a machine which will shred 20 sheets (A4 size) at once.

4. To keep the cost of construction as low as possible without compromising the final output.

## LITERATURE REVIEW

**Joseph Y. Ko** in 2000 presented a machine with automatic feeding mechanism capable of shredding 20 sheets with approx. 9 inches width. It had a three way switch i.e. On, Off and Auto. The blades were knife rollers which cut paper strips, but can be occasionally configured to have confetti-cuts of paper. Feeding mechanism contained a pair of roller to direct the paper. The rollers and the knife blades were driven by a single AC Motor and a belt drive.

**Frank Chang** in 2000 presented the blade assembly for paper shredder is in a juxtaposed manner. Conventional assembly consists of long and short partition rings. The disadvantage was that even if one part malfunctioned, the whole assembly gets loosened. Instead of having partition rings it had long and short plates casted with the blade ring. The blades were arranged on the rotary shaft to form a bladed shaft such that long and short projecting about the long and short projecting plates of adjacent blades. This arrangement eliminated use of partition rings, reducing cost and enhancing assembly efficiency.

**Gu-Ming Zeng** in 2006 presented the blades of the paper shredder that had serrated cutting edges which were formed by bending. This could be done by two methods.

The 1st method had a blade body and serrated edge integrally formed and punched from the same base material. Cost of production there was high and even high level material was required. The 2nd method had serrated cutting edges specially thickened to reduce material consumption. They were also complex to manufacture.

Three types of blades could be designed according to him–

- a. 4 serrated edges evenly spaced with one annular protrusion.
- b. 2 serrated edges with corrugulations on outer periphery.
- c. 2 serrated edges with 3 annular protrusions evenly spaced.

**Ming- Hui Ho.** in 2003 presented the paper shredder which had two rotary cutters each with multiple blades. Each blade had a first cutting blade with multiple first cutting edges and a second cutting blade with multiple cutting edges. Both the first and the second cutting blades were distributed in a non-equiangular manner and each of the first cutting edges was offset to each one of the second cutting edges, so that there was only one cutting edge that engaged with the paper to be shredded. When the amount of shredded paper increased, the paper shredder did not function normally because multiple cutting edges simultaneously engaged with the paper to be shredded paper stuck in the shredder. This problem was sorted out by using rotary cutter with multiple blades with numbers cutting edges. With the arrangement described here, the noise of the shredding was also greatly reduced.

**Willi Strohmeyer** in 1995 presented a blade and a stripper assembly for a paper shredder. Between the blades of each shaft in the cutter zone, stripper bars or fingers were provided to prevent the cut material get collected around the blade shaft. Here the stripper block had the row of stripper fingers received in the interstices between the blades. Requisite stability was attained since the fingers were engaged with the support ribs of the opposite housing. Stripper block was an injection moulding part, thus was simple construction and easy to fabricate and also had low cost.

### Gap Analysis :-

1. The blades are manufactured by gas cutting and filling process.
2. A reversible switch is attached to the motor.
3. Washers are used in between the blades.

### PROBLEM DEFINITION

1. From the reference papers, we find out the problem in the Shredder machine that, due to the load factor noise and extreme vibrations are generated.
2. The normal cutters used, which are able to shred/cut papers into strips can't be considered as a reliable method of disposing the stuff. The strips are easy to be arranged or assembled again by some wiser brains.
3. Because of the mechanical components like the blades, gears, etc a periodic maintenance and through lubrication is required.
4. There can be a problem of paper jam due to the back flow of paper along with the blades.

### METHODOLOGY:-

1. The very basic and important step was to study the basics of the shredder machine. It included the machine element. The main component of a paper shredder machine is the blade. Thus our more focus is on the research and the study of an appropriate blade design which will serve our purpose.
2. Once the blade type is fixed, the second important thing is the machine design. The design was be done in CAD SOLIDWORKS 14. The different components designed along the blade are frame/stand, shaft, washers, gears, pulley etc. Thus the designing phase is briefly classified as the machine construction, cutting system and the transmission system. The main aspect while design is the space occupation. Our main aim is to create a horizontal machine (like a Xerox ones) such that the space occupied will be horizontal in nature.

3. Once the CAD Modelling is done the next step is the material selection. The material for the blade and the frame is mild steel. Gears and pulleys are made of cast iron.
4. The next step is the analysis. The analysis is any will be done in the ANSYS15. If the results are satisfactorily then the actual manufacturing will start.
5. Before starting the actual fabrication, it is necessary to test the blade design, whether it works or not.
6. Depending upon the prototype results, the actual manufacturing will start. If there is any error, then the modifications will be done in the existing design

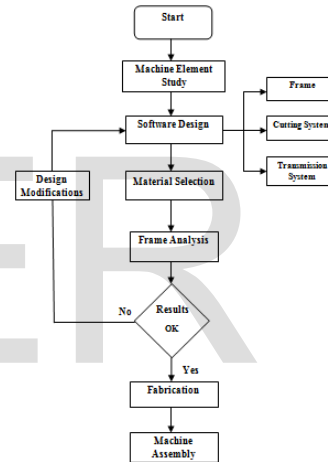

Fig 1:- Methodology

### SYSTEM DESIGN

Software used for designing “Dassault Systems SOLIDWORKS 2014.”

Paper shredder machine from design point of view consists of three main parts:-

- Machine construction
- Cutting system
- Transmission system

## MACHINE CONSTRUCTION

1. Construction machine consists of stand, bearing support plates, bearings, nuts and bolts.
2. The machine frame is made of steel angle-shaped profile with a size of 75 x 75 x 5 mm which is connected through welding process.
3. The material used for the machine frame is ASTM A36 so that the welding process can use arc welding.
4. A36 has a density of 7,800 kg/m<sup>3</sup>

### Stand/Frame:-

Material Used: - Mild Steel (ASTM A36)

Fig 4.1 shows the frame structure of the machine. All the machine components are mounted on this frame. In order to get the required strength, two plates (Bearing support blades) are fixed with the help of nut and bolts. The method used for fabrication is Arc Welding.

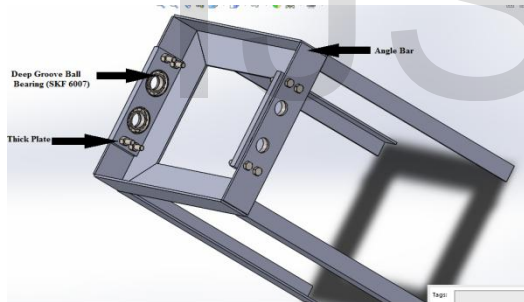

Fig 2:- Frame Model

### Frame Analysis:-

The analysis of frame was done to check whether it can support the load of the blades and shaft assembly. The analysis was done in ANSYS15.

The procedure was as follows:-

1. The CAD Model was prepared in SOLIDWORKS14 and was saved with .x\_b extension.
2. This file was then imported in Ansys15.
3. Material selected was Structural Steel.

4. Meshing with coarse sizing and 0 relevance was done and the bottom of the stand was fixed.

5. Loading:-

Load Calculations-

The frame will support the shaft assembly with includes a shaft, blades and a gear.

Weight of shaft – 5.3 kgs.

Weight of a blade - .648 kgs.

Weight of a gear - .6 kgs.

Thus weight of a single shaft assembly –

$$5.3 + .648 \times 9 + .6 = 11.73 \text{ kgs.}$$

Thus for safer size we will consider weight = 15 kgs i.e. 150 N.

6. Results:-

For the above calculations following results were obtained –

Fig 4.3 shows the results of the frame analysis performed in ANSYS15.

Total Deformation: - 0.012128 mm

Equivalent Strain: - 0.0001512

Equivalent Stress: - 10.229 Mpa

7. Conclusion:-

Since the allowable stress for A36 is 250 Mpa, we can conclude that the design is safe for the above loads.

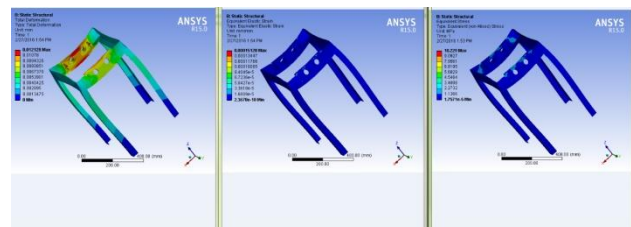

Fig 3:- ANSYS Results

## Cutting System

The system consists of the main shaft, cutting blades, washers and main shaft gears.

**Main Shaft:-**

The main shaft serves as the cutting blade holder. The main shaft has a hexagon shape in the position of cutting blade holder and has a round shape at both ends in the position of the holder main bearings and gears. The main shaft is made of EN8 AISI 1040 material with a minimum distance between two parallel sides of 38 mm.

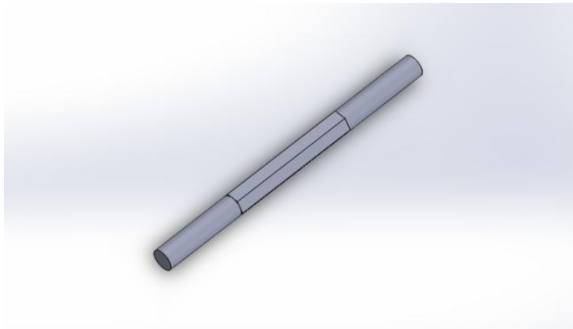

**Fig 4:-** Shaft Model

**Cutting Blade:-**

Fig 4.4 shows the CAD design of the blade whereas fig 4.7 shows the actual manufactured sample. The cutting blade is round-shaped blade with 3 (three) cutting edges, given a hexagon-shaped hole in the middle, mounted on the main shaft and main shaft move together. This blade is used to cut the paper in vertical direction. Cutting blades are designed with Mild Steel material with the specification are 18 blades, 10 mm thick and 51-degree of cutting angle.



**Fig 6:-** Blade Model and Manufactured Sample

Fig 4.5 shows the modifications in the blade design. Thus few modifications were made in the 1st design. The stress concentration problem was solved by creating a tangent in a side edge. Though this problem was solved, the weight of this blade came out to be 722 grams which was more than the 1st design.

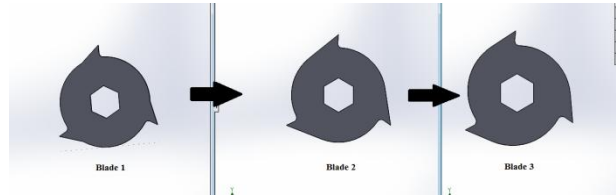

**Fig 5:-** Modifications in Blade Design

In the 3rd modification, the weight was reduced. The first two blades had a perfect circle of dia. 110mm with a single centre. In this design, the size was reduced. Instead of radius 55mm which had a common centre, this blade was designed in such a way that a 55mm arc would develop and all the three arcs had three different centres such that these three centres would form an equilateral triangle. The weight was 648 grams.

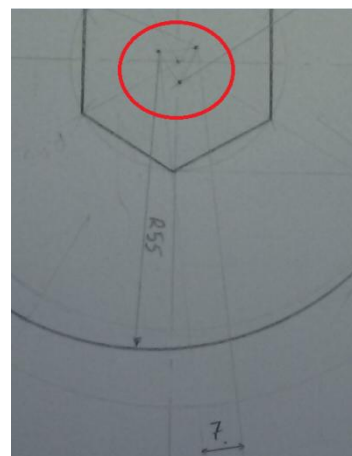

**Fig 7:-** Equilateral triangle formation

Procedure followed in manufacturing a blade:-

- Hand Drawing (with the dimension lesser than the actual required ones).
- Template Making.
- Gas Cutting.
- Surface Grinding.
- Curve Filling.

#### Shaft Assembly:-

Fig 4.7 shows the shaft assembly. The shaft assembly consists of blades washers and the gears. The blade part is as discussed above. The washers are again made of MS. The shape of the washer is normal ring form and its only function is to align and lock the blades such that they do not move during operation. They are total 20 in number with 2 of them with a lock nut. The main shaft gear consists of two spur gears paired with the size (number of teeth 25 and modules 4).

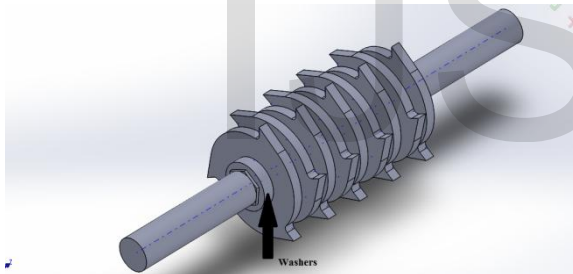

Fig 8:- Shaft Assembly

#### **Transmission System**

1. The transmission system is one of the main parts of the paper shredder machine that serve to forward rotation or power from the electric motor to the cutting system.
2. Transmission system uses a series of gears with a certain ratio to reduce the rotation.
3. The transmission system consists of V-belt pulleys and spur gears.
4. Two pulleys are used. A 3" pulley is mounted to the motor shaft. It transmits power to a 14" pulley via a V-

belt. V-belt is used because of its advantages over flat-belts like the compactness, no slip, longer life, etc. The reduction ratio of 4.67 is obtained.

5. The gear system consists of 2 stage transmission.

Each pair having a gear of 18 and 34 teeth's respectively. Module of the gears is 4 which is obtained by calculation and the reduction ratio obtained is 1.89.

6. Thus the overall reduction ratio obtained is 16.67.

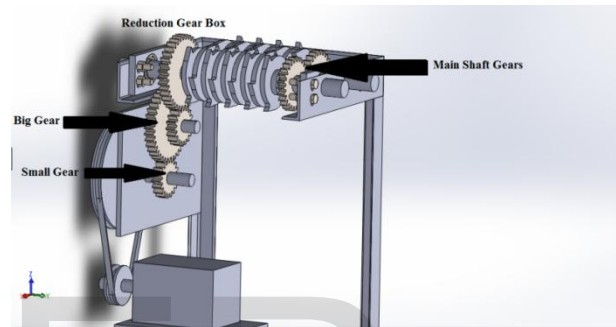

Fig 9:- Transmission System

#### **Prototype Testing:-**

Fig 4.9 shows the prototype. This was very important step in our project. In order to check whether the above blade design works or not, a small prototype of the desired machine was made.

Material used:-

Wood – for framework and the shaft

Mild Steel – for cutting blades

It consisted of only 5 blades and which were of the smaller size than the actual ones. It was observed that the paper was cutting roughly. In the prototype, fine strips were not obtained due to some alignment problem.



Fig 10:- Model Prototype

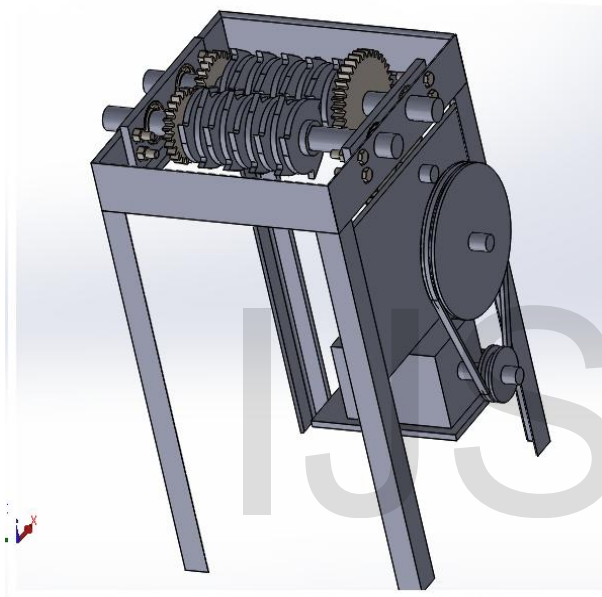

Fig 11:- Full Assembly

## CONCLUSION

In this project we conclude that there are many parameters on which the total project is dependant i.e. total knowledge about the system, design of a single blade and its arrangement of the main shaft, reduction in rotation.

The motion study in SOLIDWORKS14 was successfully carried out when the whole assembly was completed. The frame needed some basic analysis to check whether it could take over the load or not. The following analysis was done in ANSYS15 and the results were positive. Before starting the actual fabrication, we conducted a trial on our prototype just to

ensure the desired results with our design. The prototype testing was also positively conducted.

The actual fabrication was started over prototype testing. There was a problem in gear alignment and the bearing plate fitting. Also we need to change our reduction gear position at the end due to the pulley arrangement. These difficulties were overcome by some expert advices. There was a problem of paper jamming which was eliminated by the use of stripper fingers. There are very less vibrations in the actual machine. Finally, I conclude that if u are hardworking than u can do everything.

## RESULT

As we made the design according to requirements, the necessary calculations were also carried out. In the last stage i.e. checking whether the machine runs properly or not, it was observed that the paper was getting cut into strips but it was returning again with the blades. This did not allow us to put the other sheet. If other sheet was put, the machine used to stop automatically. This problem was eliminated with the help of a component called as "Stripper Fingers". It was similar to a hand comb. These fingers restricted the return path of the paper. Thus paper had no other option but to enter the bin. Thus the above problem was eliminated with the help of these fingers.

## Machine Specifications:-

Insertion Width	220 mm
Cut Style	Strip Cut
Cutting Width	188 mm
Machine Dimensions	450 x 450 x 675 (W x B x H)
Manual Reverse	Yes
Shreds	Paper, Staples

## REFERENCES

- [1] Joseph Y. Ko, 2002, "Paper Shredding Device", US 6390397 B1.
- [2] Frank Chang, 2000, "Blade Assembly For Paper Shredder", US 6089482, BO2C 18/06, BO2C 18/18.
- [3] Gu-Ming Zeng, 2006, "Blade Of Paper Shredder", US 2008/0040934A1.
- [4] Li-Ming Wu Huang, 2002, Taipei (TW), "Blade Of Paper Shredder", 6390400B1.
- [5] Ming-Hui Ho, 2003, Taipei Shein, "Blade Of Paper Shredder", 6513740B2.
- [6] S Nithyananth, Nithin Mathew, Libin Samuel, S Suraj, 2014, "Design Of Waste Shredder Machine", ISSN : 2248-9622, Vol. 4, Issue 3( Version 1), March 2014, pp.487-491.
- [7] Emily Lo, 2010, Taipei Shein (TW), "Paper Shredder Blade", 7748656B1.
- [8] Tsai, 2000, Taiwan, "Dual Function Shredder", 6065696, App. No.-09/320948.
- [9] [9]Bruce R. Kroger, Raymond R. Ferriss, 2001, "Paper Shredder Shaft", 6260780B1.
- [10] [10]Frank Chang, 2001, Taipei, "Gear Protection Device Of A Paper", 6325309B1.
- [11] Emily Lo, 2008, Taipei Shiepei (TW), "Blade For Paper Shredder Cutting Tool", 7328867B1.
- [12] Simon Hunag, 2006, San Chung (TW), "Elliptical Acetabuliform Blade For Shredder", 6981667B2, App. No. 10/682198.
- [13] Frank Chang, 2005, Taipei (TW), "Linkage Mechanism Of Paper Cut And Antiblock Of Double Duty Shredder", 6966513B2.
- [14] Chen, 2010, Shanghai (CN), "Cutter Structure Of Shredder Blade", 7641136B2.
- [15] Simon Hunag, 2011, Shan chung (TW), "Rotation Speed Controlling System For Shredder Motor", 8008882B2.
- [16] Simon Hunag, 2006, Shan Chung, "Shredder Blade Made By Punching And Bending", 7048218B2.
- [17] Tie Chun Wang, 2008, San Chung (TW), "Device For Reducing Vibrations And Noises Of Paper Shredder", 7445173B2.
- [18] Mark S. Allen, Butter cup Legacy, LLC, Orem, UT (US), 2007, "Lubricant Carrying Substrate For Maintenance For Paper Shredder", 716656B2.