



# INTERNATIONAL JOURNAL OF ADVANCE RESEARCH, IDEAS AND INNOVATIONS IN TECHNOLOGY

ISSN: 2454-132X

Impact factor: 4.295

(Volume3, Issue2)

## Design and Fabrication of Pipe Bending and Pipe Rolling Machine

**Thorave Rohit .V**

Student,

Department of Mechanical Engineering,  
D.I.E.T. Sajjangad, Satara-415002,  
Maharashtra, India.

**Pendse Ashutosh .S**

Student,

Department of Mechanical Engineering,  
D.I.E.T. Sajjangad, Satara-415002,  
Maharashtra, India.

**Kumthekar Shiriraj .V**

Student,

Department of Mechanical Engineering,  
D.I.E.T. Sajjangad, Satara-415002,  
Maharashtra, India.

**Patil Akash .P**

Student,

Department of Mechanical Engineering,  
D.I.E.T. Sajjangad, Satara-415002,  
Maharashtra, India.

**Pawar Shivam .G**

Student,

Department of Mechanical Engineering,  
D.I.E.T. Sajjangad, Satara-415002,  
Maharashtra, India.

**Dhende S. S**

Assistant Professor, Department of  
Mechanical Engineering, D.I.E.T.  
Sajjangad, Satara-415002,  
Maharashtra, India.

---

**Abstract:** This paper presents the design and fabrication of combined pipe bending and pipe rolling machine. There is no single machine made to perform both rolling and bending operations. Hence we have selected this project to design and fabricate combined bending and rolling of pipe using single power source. The defects occur during bending are too much tedious to eliminate. While designing the machine we tried to minimize defects and minimize the initial cost of the machine. Using this machine both bending and rolling of pipe of outer diameter 19 mm and thickness 1-2 mm is possible with single power source only.

**Keywords:** Pipe Bending, Pipe Rolling, Rollers, Rotary Draw Bending And Three Roll Bending.

---

### I. INTRODUCTION

Pipe bending and rolling are two important types of metal forming processes used to deform pipes or tubes permanently for various applications. A bending machine is used to bend a variety of single or multiple bends and to shape the pipes into the desired form. Similarly, a rolling machine is used to roll the pipe to form various radius curves in the pipe and 360° rings. For these two operations previously two separate machines are used. We tried to develop one single machine on which both bending and rolling operations are performed. We have selected rotary draw bending method for bending operation and three roller bending method for rolling operation. These two methods are combined in one single machine to work smoothly and efficiently.

### II. DESIGN CALCULATIONS

The whole machine elements are designed using books "Design of machine elements" by author V.B Bhandari and "P.S Gill Design data book"

#### 2.1 Selection of Pipe

In industry 1/2", 3/4" and 1" pipes are commonly used. For our project, we selected 19 mm (3/4 inch) diameter pipe as it would be economical. Pipe specifications: OD ( $D_p$ ) = 19 mm, ID ( $d_p$ ) = 17 mm  
Pipe material: Cold rolled Mild Steel, Sut = 350 Mpa, Syt = 195 Mpa

#### 2.2 Design of Rollers

The diameter of pipe ( $D_p$ ) is 19 mm (3/4 inch). The material selected for the roller is Case hardened steel. For fewer defects in bending take big roller diameter 5 times pipe diameter and small roller diameter 3 times pipe diameter.

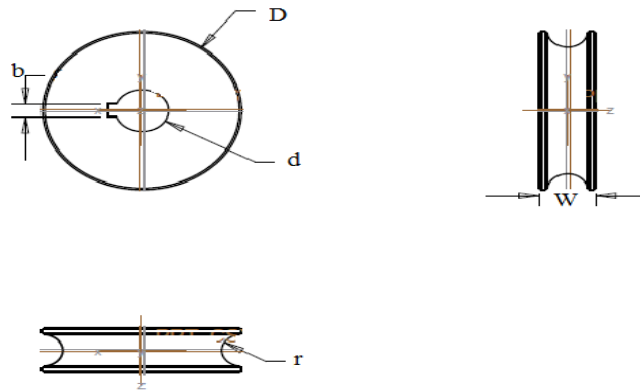

Figure 2.1 Roller dimensions

So

Big Roller diameter = **95 mm**

Small Roller diameter = **57 mm**

### 2.3 Design of Bending Die:

For bending roller diameter it is usually taken 5 times diameter of the pipe.

So, Bending Roller diameter = **95 mm**

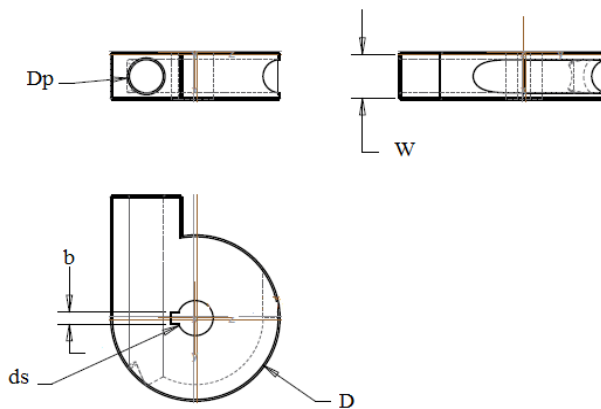

Figure 2.2 Bending die dimensions

Clamp dimensions are,

Width (w) = **20 mm**

Height (h) = **27 mm**

Length (l) = **70 mm**

Circular groove radius (r) = **9.5 mm**

### 2.4 Bending Force and torque calculation:

Assuming Stress required bending the pipe is yield stress ( $S_{yt}$ ).

So, Stress required to bend pipe ( $\sigma_b$ ) =  $S_{yt}$  = **195 Mpa**

Force required to bend = **5666.647 N**

Torque required to bend = **269.1657325 Nm**

### 2.5 Motor Specifications:

Motor Specifications are

Power (P) = **1HP (0.746 kW)**

Speed (N') = **1440 rpm**

Supply = **Three phase**

For speed reduction- Belt drive system used:

From belt drive, we have achieved reduction ratio 4 that is From (N') 1440 to (N) 360 rpm.

Torque available at reduced speed end = **19.78 Nm**

### 2.6 Design of pulley and belt:

Motor shaft speed (N') = **1440 rpm**

Output shaft speed (N) = **360 rpm**

Using design data book and reference book V. B Bhandari we have designed pulleys and belt

Following are the specifications,

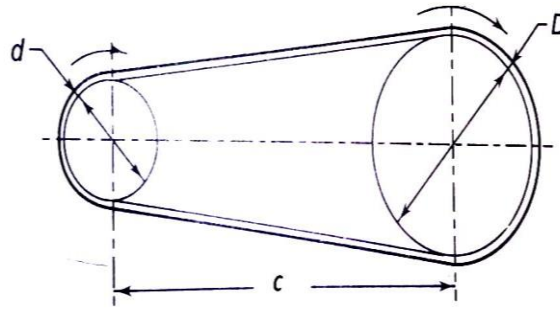

Figure 2.3 Belt drive

Design power= **0.825 kW**  
 Smaller pulley diameter = **75 mm.**  
 Bigger pulley diameter = **300 mm.**  
 Pitch length of belt=**1250 mm**  
 Centre distance **C=310 mm**  
 Number of belts = **1**

**2.7 Design of Worm and Worm Wheel:**

Torque required = **269.165 Nm**  
 Torque available = **19.78 Nm**  
 Transmission ratio = **14:1**  
 For transmission ratio select  $Z_1 / Z_2 / q / m = 2 / 31 / 11 / 3$

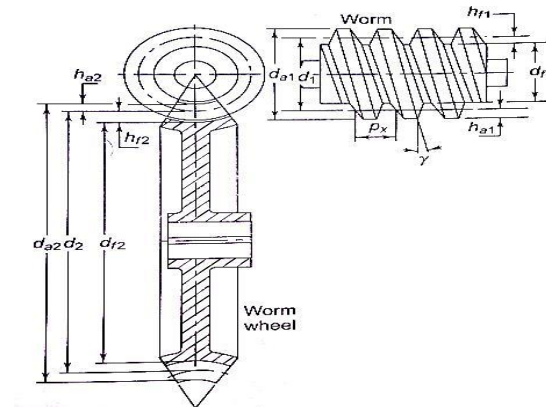

Figure 2.4 Worm and worm wheel

Centre distance= **63 mm**  
 Dimension of worm  
 $d_1 = 33 \text{ mm}$   
 $da_1 = 39 \text{ mm}$   
 $\gamma = 10.30^\circ$   
 $df_1 = 26.1 \text{ mm}$   
 Pitch = **9.424 mm**  
 Dimension of worm wheel  
 $d_2 = 93 \text{ mm}$   
 $da_2 = 98.8 \text{ mm}$   
 $df_2 = 85.81 \text{ mm}$

**2.8 Design of Lead Screw:**

Assuming single threaded square lead screw.

Let,  
 The material of screw is Grey C.I. (FG 200) and a factor of safety be 3.  
 Nominal diameter ( $d_i$ ) = **20 mm**  
 Pitch ( $p$ ) = **3 mm**  
 OD of collar ( $D_o$ ) = **40 mm**  
 ID of collar ( $D_i$ ) = **20 mm**  
 Coefficient of Friction ( $\mu$ ) = **0.15**  
 Load ( $W$ ) = **5666.647 N**

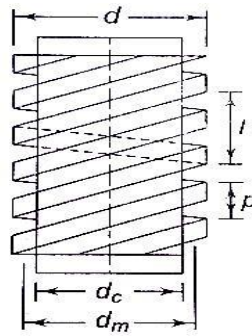

Figure 2.5 Power Screw

Mean diameter ( $d_m$ ) = **18.5 mm**

Core diameter ( $d_c$ ) = **17 mm**

Lead ( $l$ ) = **3 mm**

Pitch angle:

$\Phi = 8.53$  degrees

Helix angle:

$\alpha = 2.955$  degrees

Torque required is,

$M_t = 10650.917$  Nmm

Collar  $M_t = 12750$  Nmm

Total  $M_t = 23401$  Nmm

Force required to advance lead screw = **234.01 N**

Allowable Compressive and shear stresses:

$\sigma_c = 66.67$  N/mm<sup>2</sup>

$T = 33.33$  Nmm

Since both Compressive and shear stresses developed in lead screw are less than allowable stresses hence Design of Lead screw is safe against crushing and shearing failure.

### 2.9 Design of Shaft:

Material selected for all shafts is 40C8 steel

After calculation, it is found that shaft design is safe on torsional basis

Hence, shaft diameter is **25mm**

Motor pulley shaft:

[Torsional moment consideration]

Diameter of shaft = **25 mm**

Big pulley shaft:

Diameter of shaft = **25 mm**

### 2.10 Design of Bearing:

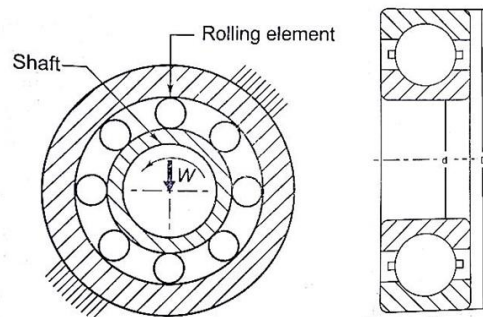

Figure 2.8 Single groove Ball bearings

Selected bearing is, **Bearing no. 6005**

With,

Housing diameter ( $D_b$ ) = **47 mm**

Internal diameter ( $d_b$ ) = **25 mm**

Width of bearing ( $w_b$ ) = **12 mm**

And static load carrying capacity ( $C_0$ ) = **5600 N**

### 2.11 Design of Key:

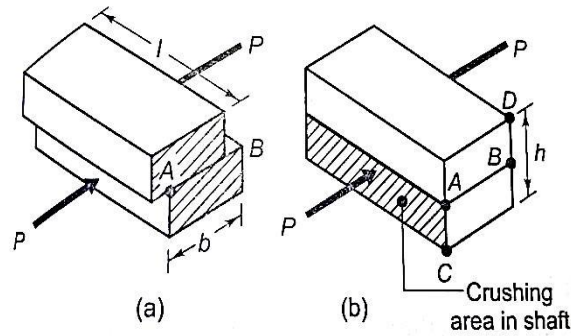

Figure 2.5 Square key

Key dimensions are,

Width and height of key

$$b = h = d / 4$$

$$= 25 / 4$$

$$= 6.25 \text{ mm}$$

$$= \mathbf{7 \text{ mm}}$$

Length of key:

$$L = \mathbf{45 \text{ mm}}$$

So, key dimensions are  $\mathbf{7*7*45 \text{ mm}}$ .

#### FABRICATED MODEL OF MACHINE



Figure 3.1 Setup of machine for rolling operation



Figure 3.2 Setup of machine for bending operation

#### CONCLUSION

The project design and fabrication work completed successfully. After experimentation on the machine we conclude that we can perform both pipe bending and pipe rolling operation on this machine (one operation at a time). Machine uses single power source i.e. three phase motor which reduced the capital cost of the machine. The setup change required for performing operations which is quite easy. The machine is capable of bending and rolling off only 19 mm diameter pipe, however, the pipe used during test is of mild steel, therefore, we can conclude that the pipes of a softer material than mild steel can also be bend using this machine.

#### REFERENCES

- [1] Mr. V.B.Bhandari, "Design of machine element", Tata Mc- Graw Hill Publication, 3<sup>rd</sup> Edition 2010.
- [2] Mr. P.S.Gill, "Design Data Book", 3<sup>rd</sup> Edition.