



**DESIGN CRITERIA
MANUAL
CHAPTER 7 PUBLIC
TRANSPORTATION**

MUNICIPALITY OF ANCHORAGE

**PROJECT MANAGEMENT &
ENGINEERING DEPARTMENT
AND PUBLIC TRANSPORTATION**

JANUARY 2007

TABLE OF CONTENTS

SECTION 7.1 OBJECTIVES.....	7-1
SECTION 7.2 TRANSIT VEHICLE GEOMETRIC CONSIDERATIONS.....	7-2
7.2 A Objectives.....	7-2
7.2 B Design Vehicle City Transit Bus (CITY BUS)	7-2
7.2 C 30-Foot DART Bus	7-6
7.2 D Transit Van.....	7-6
SECTION 7.3 BUS STOP LOCATION AND TYPE.....	7-7
7.3 A Objective.....	7-7
7.3 B Bus Stop Spacing and Location	7-7
7.3 C Bus Stop Type – On-Street or Off Street?.....	7-15
SECTION 7.4 BUS STOP DESIGN.....	7-18
7.4 A Objectives.....	7-18
7.4 B Design	7-18
7.4 C Facility Access.....	7-23
7.4 D Bus Stop Amenities	7-25
SECTION 7.5 OTHER TRANSIT FACILITIES	7-34
7.5 A Bus Layover Areas	7-34
7.5 B Park-and-Ride Amenities.....	7-34
 FIGURES	
FIGURE 7-1 CITY TRANSIT BUS (CITY BUS, 40-FOOT BUS).....	7-3
FIGURE 7-2 MINIMUM TURNING PATH FOR CITY TRANSIT BUS (CITY BUS) DESIGN VEHICLE.....	7-4
FIGURE 7-3 UNDERBODY CLEARANCE FOR DRIVEWAY DESIGN.....	7-5
FIGURE 7-4 BUS STOP LOCATION FLOWCHART	7-8
FIGURE 7-5 BUS STOP TYPE FLOWCHARG	7-9
FIGURE 7-6 BUS STOP SPACING CRITERIA - ANCHORAGE.....	7-11
FIGURE 7-7 BUS STOP SPACING CRITERIA – EAGLE RIVER	7-12
FIGURE 7-8 NEAR- AND FAR-SIDE CURB EXTENSION AT INTERSECTION	7-19
FIGURE 7-9 BUS STOPS WITH CURB EXTENSION	7-20
FIGURE 7-10 ON-STREET BUS STOP LAYOUTS	7-21
FIGURE 7-11 GEOMETRIC LAYOUT FOR TYPICAL BUS TURNOUT.....	7-22
FIGURE 7-12 GEOMETRIC LAYOUT FOR TYPICAL BUS STOP PAD.....	7-24
FIGURE 7-13 FULLY DEVELOPED BUS STOP WAITING AREA.....	7-26
FIGURE 7-14 PASSENGER SHELTER	7-28
FIGURE 7-15 TYPICAL BUS STOP SIGN	7-30
FIGURE 7-16 BUS STOP A-FRAME SIGN AND SCHEDULE HOLDER.....	7-31
FIGURE 7-17 BUS STOP LIGHT	7-32
FIGURE 7-18 TYPICAL PARK-AND-RIDE APPLICATIONS WITH VARYING SITE CONDITIONS	7-35

TABLES

TABLE 7-1 MINIMUM ON-STREET BUS STOP REQUIREMENTS7-18

APPENDICES

APPENDIX 7A	GLOSSARY
APPENDIX 7B	REFERENCES

Acronyms and Abbreviations

AADT	annual average daily traffic
AASHTO	American Association of State Highway and Transportation Officials
ABA	Architectural Barriers Act
AC	asphalt concrete
ADA	Americans with Disabilities Act
ADAAG	Americans with Disabilities Act Accessibility Guidelines
ADT	average daily traffic
ALUM	aluminum
ANSI	American National Standards Institute
ASTM	American Society of Testing Materials
AWS	American Welding Society Specifications
CITY BUS	AASHTO City Bus
CBD	Central Business District
DCM	Design Criteria Manual
DOT&PF	State of Alaska Department of Transportation and Public Facilities
DPW	State of Alaska Department of Public Works
FHWA	Federal Highway Administration
Ft	feet
ELEC	electricity
GALV	galvanized
IAW	in accordance with
In	inch
Lb	pound
LOS	level of service
MASS	Municipality of Anchorage Standard Specifications
MUTCH	Manual on Uniform Traffic Control Devices (FHWA)
OS&HP	<i>Official Streets and Highways Plan</i>
NCHRP	National Cooperative Highway Research Program
Max	maximum
Min	minimum
MOA	Municipality of Anchorage
MPH	miles per hour
PCC	Portland Cement Concrete
PGDHS	<i>Policy on Geometric Design of Highways and Streets (AASHTO)</i>
PM&E	Municipality of Anchorage Project Management and Engineering
PTD	Municipality of Anchorage Public Transportation Department
ROW	Right-of-Way
TYP	typical
USDOT	United States Department of Transportation

SECTION 7.1 OBJECTIVES

These guidelines describe the recommended methodology for the location and design of bus stops and other public transportation facilities within the Municipality of Anchorage. The initial version of the design guidelines was written and distributed by the Municipal Transit Department in 1986, and was revised in 1993, 2002 and 2005. Passage of the Americans with Disabilities Act (ADA) and the evolution of Municipal and State roadway design have prompted this update.

A number of specific elements are included—transit vehicle dimensions, guides to the location and design of bus stops, proper placement of amenities at bus stops, and general guidelines for the design of other transit facilities such as layover areas and park and ride lots. The primary objective of this effort is to provide engineers, designers, and planners one document to aid in the functional, legal and cost-effective development of transit-related road improvements.

The Public Transportation Standard Details for Construction are available by contacting the Municipality of Anchorage Public Transportation Department Planning Division or Project Management and Engineering Design Division.

Although the process of locating and designing bus stops would appear fairly simple to the casual observer, creating a design with optimal transit facilities requires consideration of many factors. For example, the ideal arrangement of bus stops from the transit user's point of view includes frequent stops in the travel lane of the roadway. Additionally, sidewalks and trails kept free of snow and connecting to his or her destination, ensure the quickest and safest possible trip. From the perspective of other drivers on the road, however, the ideal arrangement of bus stops would feature infrequent stops placed in turnouts out of the travel lane. These updated guidelines endeavor to order and clarify the factors to consider, and to guide the user toward a balancing of the needs of all roadway users.

From the transit user's perspective, the quality of transit service is a product of the travel time

between origin and destination, and the perceived comfort (or discomfort) of the trip. Both travel time and perceived comfort include the walk to the bus stop, the bus trip itself, and the walk to the destination. Access or walking time and relative comfort are a direct result of planning and design decisions that affect the ability of pedestrians to get to and from the bus stop. Every transit rider is a pedestrian at least once, and usually twice, during his or her trip. Walks to and from the bus stop made circuitous due to fences, subdivision layout, drainage ditches, earthen berms, snow plowing and other obstructions, require extra time and vary from unpleasant to impassible, depending on the hardness of the individual.

Walks to bus stops that place the pedestrian at risk because of excessive slopes, lack of pathways, no buffer between high speed traffic, etc., are a significant disincentive to transit use. This is especially true in the winter. Unmaintained walkways deep with snow force transit riders to walk in the road with vehicular traffic. The lack of buffers often produces a situation during "break up" where, because drains are located at curbside and/or the road surface becomes rutted through use, unwary pedestrians can be drenched by water spray.

Improved pedestrian sidewalks, paths and trails connected to bus stops will make using the transit system safer and more enjoyable. Appropriately located turnouts will enhance user safety while minimizing delay to traffic. On inner urban roads, on-street stops are preferred for greater transit efficiency. As barriers to transit use are removed, the transit system will become easier for all residents, and particularly individuals with disabilities, to use.

END OF SECTION 7.1

SECTION 7.2 TRANSIT VEHICLE GEOMETRIC CONSIDERATIONS

7.2 A Objectives

All street design should consider the existing or future presence of transit vehicles in the traffic stream. This section presents the current design vehicles in use by the Public Transportation Department's (PTD) People Mover services and their horizontal and vertical clearance requirements. Because transit vehicles are rarely the largest design vehicle anticipated on a roadway facility, most street and highway design controls accommodate transit vehicles. However, the road designer should verify that the design controls developed in this section are satisfied. Where a design criterion is not addressed in this section, the appropriate street and highway design control should be used.

7.2 B Design Vehicle: City Transit Bus (CITY BUS)

People Mover currently uses 40.5-foot long, 8.5-foot wide New Flyer buses in its fleet. The physical characteristics of this bus size should be considered in all transit-related design controls. Because the critical dimensions for this vehicle are consistent with the American Association of State Highway and Transportation Officials (AASHTO) City Transit Bus (CITY-BUS), this Design Vehicle shall be used in determining transit-related geometric design requirements. Figure 7-1 depicts the basic front and side views of a 40-foot bus and summarizes its critical dimensions and clearance requirements of the model the system currently operates.

1. Horizontal Clearance - Turning Movements

a) Desirable Curb Return Radius

The desirable curb return radius for transit buses with 12-foot entrance and departure lanes is 40 feet. This radius is typically used in arterial applications, with 30 feet standard for collectors and 20 feet for residential streets. It should be noted that for 90-degree turns with

curb return radii less than 40 feet, the transit design vehicle will swing into the intersecting street's opposing traffic lane while negotiating the turn.

b) Minimum Turning Path

Figure 7-2 presents the Minimum Turning Path for an AASHTO CITY BUS design vehicle. This template should be used to design curve radii and entrance/exit throats on approaches for roadways where transit buses will operate. It is desirable to avoid requiring buses to encroach into oncoming lanes or overhang sidewalks during turning movements.

As indicated in Figure 7-2, the CITY BUS design vehicle turns on a minimum inside clearance radius of 24.4 feet and requires an outside clearance ranging between 44 feet for a 30-degree turn to 46.5 feet for a 180-degree turn.

Satisfactory horizontal clearance at turns should be verified by the application of appropriate turning path templates. Additional radius should be provided if bus-turning speeds are expected to be greater than 10 mph. Anchorage's desired speed for 90-degree turns is 3 to 5 mph.

2. Horizontal Clearance – Lane Width Requirements

a) Travel Lanes and On-Street Bus Stops without Shoulders, Parking and/or Bike Lanes

Current Municipal Project Management and Engineering Department (PM&E), Alaska Department of Transportation and Public Facilities (DOT&PF), and AASHTO travel lane width requirements (10 to 12 feet) accommodate the BUS design vehicle. Consequently, no special requirements for bus lanes or on-street bus stops are necessary.

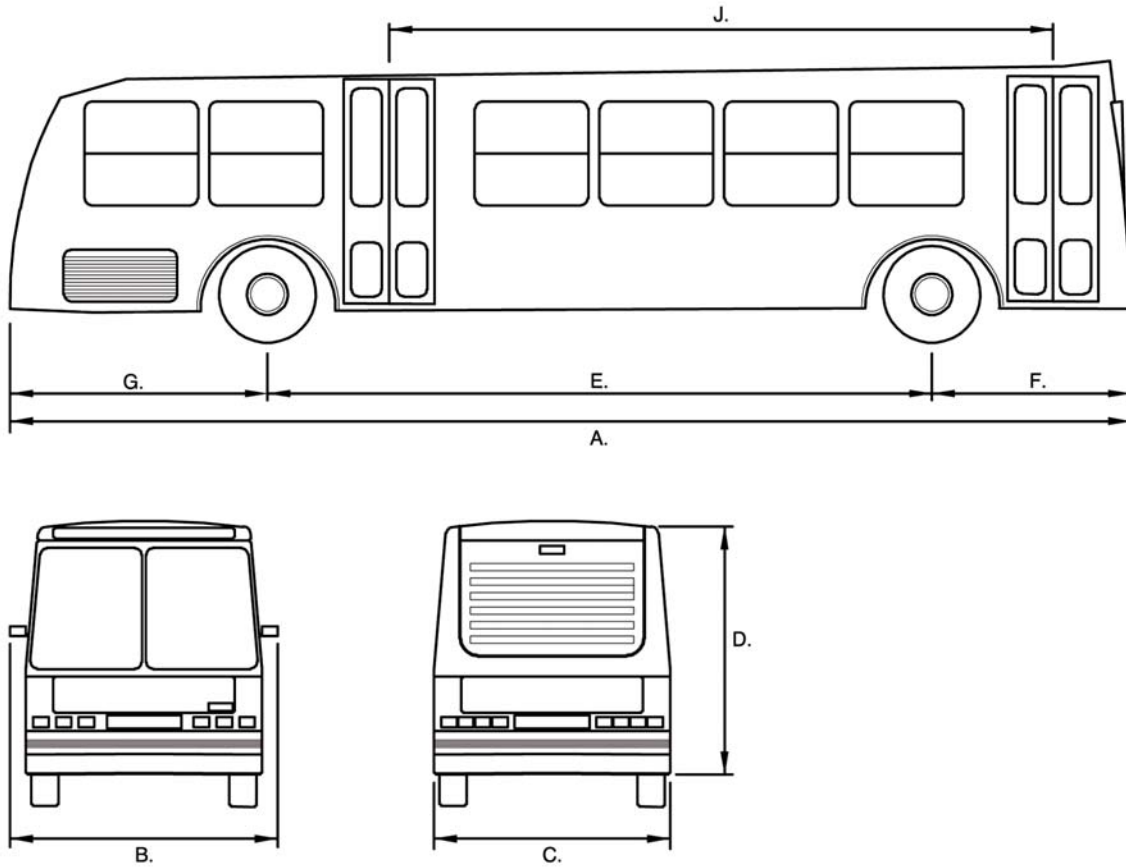

- A. Overall Length
- B. Overall Width (with mirrors)
- C. Overall Width (without mirrors)
- D. Overall Height
- E. Wheelbase Length
- F. Front Overhang
- G. Rear Overhang
- H. Weight (empty)
- I. Seating Capacity
- J. Door to Door

Dimension	Dimension	
	New Flyer	GMC
A. Overall Length	40 ft.-6 in.	40 ft.-0 in.
B. Overall Width (with mirrors)	11 ft.-0 in.	10 ft.-6 in.
C. Overall Width (without mirrors)	8 ft.-6 in.	8 ft.-6 in.
D. Overall Height	9 ft.-3 in.	10 ft.-0 in.
E. Wheelbase Length	24 ft.-5 in.	23 ft.-9 in.
F. Front Overhang	7 ft.-0 in.	7 ft.-9 in.
G. Rear Overhang	9 ft.-6 in.	8 ft.-6 in.
H. Weight (empty)	26,400 lbs.	24,000 lbs.
I. Seating Capacity	39	50
J. Door to Door	21 ft.-2 in.	19 ft.-0 in.

City Transit Bus (City-Bus, 40-Foot Bus)

Not to Scale

Anchorage Transit Design Guidelines

FIGURE 7-1 CITY TRANSIT BUS (CITY-BUS, 40-FOOT BUS)

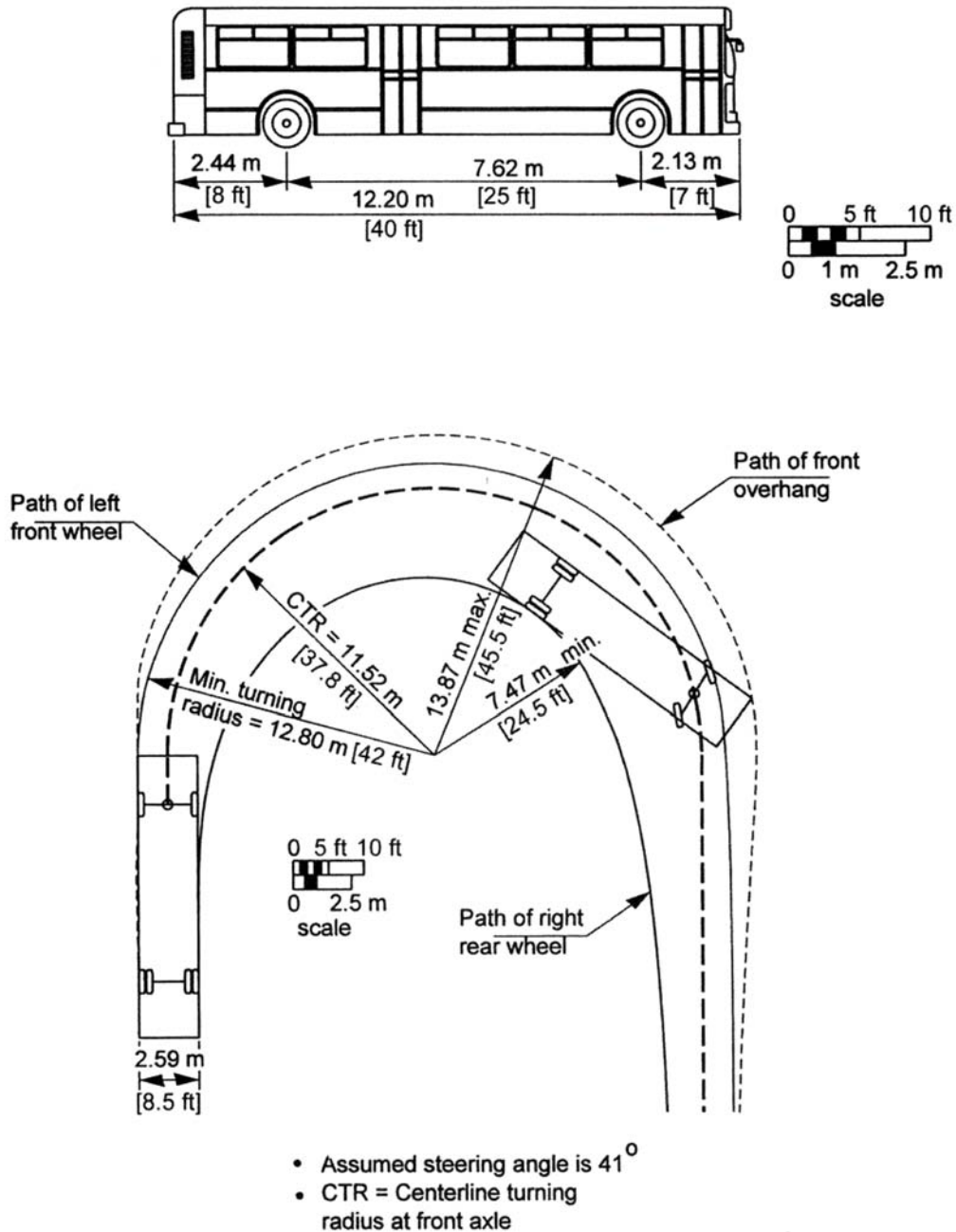

Minimum Turning Path for City Transit Bus

Source: Geometric Design of Highways and Streets 2004 - Exhibit 2-7

Anchorage Transit Design Guidelines

FIGURE 7-2 MINIMUM TURNING PATH FOR CITY TRANSIT BUS (CITY-BUS) DESIGN VEHICLE

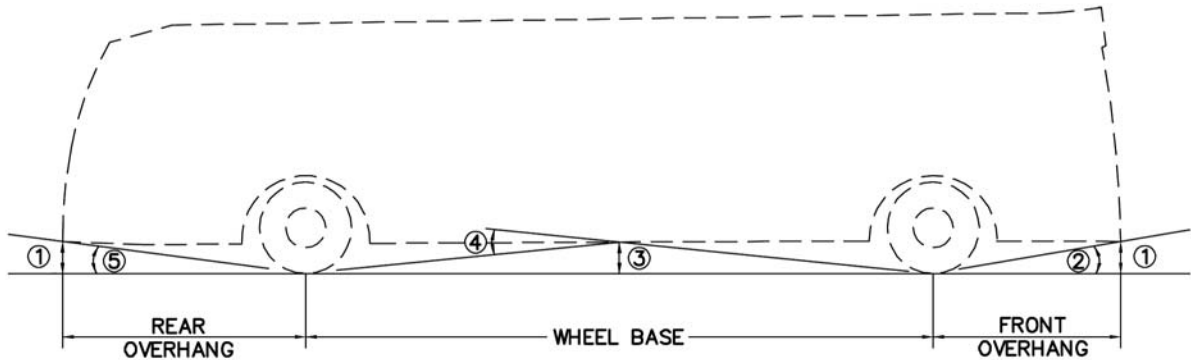

	Degrees	Dimension
① Ground to Bumper Clearance	–	10” Front/16” Rear
② Approach Angle	9.0°	–
③ Underbody Clearance	–	9”
④ Rollover Angle	8.3°	–
⑤ Departure Angle	9.0°	–

Underbody Clearance for Driveway Design

Source: Metropolitan Transit Commission, *Guidelines for the Design of Transit Related Roadway Improvements Anchorage Transit Design Guidelines*

FIGURE 7-3 UNDERBODY CLEARANCE FOR DRIVEWAY DESIGN

b) On-Street Bus Stops using Shoulders, Parking and/or Bike Lanes

Where parking lanes, bike lanes, or shoulders are to be used for on-street bus stops and disruption to through traffic is to be minimized, the combined width of the outside travel lane and the parking/bike/shoulder lane should be at least 20 feet.

c) Off-Street Bus Stops - Turnouts

The desirable width (as measured from lip of curb to edge of the through travel lane) for bus turnouts is 12 feet. The absolute minimum width for bus turnouts is 10 feet.

3. Vertical and Underbody Clearance

a) Vertical Clearance

Current transit buses have a maximum overall height of 9 feet, 3 inches. The desirable clearance between the roadway surface and overhead obstructions on transit routes is 16.5 feet, and the minimum is 14 feet.

b) Underbody Clearance

Underbody clearance should be considered in the design of intersections, driveways, and off-street facilities.

Grade breaks at these locations should be set so that underbody clearance is maintained during three phases of movement over a grade break: Approach, Rollover, and Departure. Figure 7-3 depicts these phases of movements and presents the maximum allowable grade breaks for transit buses: 12 percent difference for sag vertical curves and 10 percent for crest vertical curves.

7.2 C 30-Foot DART Bus

30-Foot buses are used to provide Deviated Fixed Route Transit Service. Current State of Alaska Department of Public Works (DPW), DOT&PF, and AASHTO street and highway design controls accommodate these buses. Consequently, no special design considerations are necessary for roads on which these buses are used.

7.2 D Transit Van

The Anchorage Share-a-Ride currently uses 23-foot vans. The AnchorRIDES service operated for individuals with disabilities uses 20-foot cutaway van chassis vehicles. Current DPW, DOT&PF, and AASHTO street and highway design controls accommodate these vans. Consequently, no special design considerations are necessary for roads on which vans are used.

END OF SECTION 7.2

SECTION 7.3 BUS STOP LOCATION AND TYPE

7.3 A Objective

Decisions regarding bus stop frequency, location, and length, call for careful analysis of passenger service requirements, the type of bus service provided, and the interaction of stopped buses with general traffic flow. These factors are often dependent upon existing land-use development along the road in question. Achieving a balance of convenience to the bus passenger and convenience to the auto user should be a prime objective. This section contains guidelines for selection of bus stop placement, spacing and type, along with methodologies to help the designer and planner in achieving the successful balance. Flowcharts that depict the location and stop type decision process are presented in Figures 7-4 and 7-5.

7.3 B Bus Stop Spacing and Location

The proper location of a bus stop requires a site investigation of the stop(s) under consideration; no standard type of stop can be recommended for all locations. An inventory of land-uses within a quarter-mile corridor of the road under consideration should be developed, making certain those uses which serve as major trip producers and attractors are noted. In particular, these categories should be included in the inventory:

- High-density residential units (R-3 and R-4 zoning) normally generate sizeable numbers of transit trips because of typical income levels and density.
- Public institutions (schools, hospitals, libraries, etc.)
- Office buildings

- Retail malls

1. Selection of Preliminary Bus Stop Locations

Once the major trip generators within the corridor have been identified, the next step is to begin locating bus stops. Needed transit information can be obtained from the People Mover Planning Staff, which include:

- The portion of the length of the road the route operates or will operate in the future.
- At which intersections do or will other routes connect. Assume riders will transfer from one route to another at these intersections.
- Number of boardings and alightings by stop, if the road has existing stops.
- Forecasted boardings and alightings, in cases in which development is anticipated.

2. Sequence of Decisions

Step 1: Stops at Major Generators

The first stops established are those adjacent to major trip generators. Stops should be located within a short walk from schools, major retail malls, office buildings and multi unit apartments to provide access to the public transportation system. At these major passenger generators, bus stops should be located to balance rider access with pedestrian safety. Stops should be located close to the main entrance to minimize the distance users have to travel through parking lots. Stop locations should minimize the potential for jaywalking as well as minimizing user walking distance and avoiding unnecessary crosswalk movements (disincentives for public transportation users).

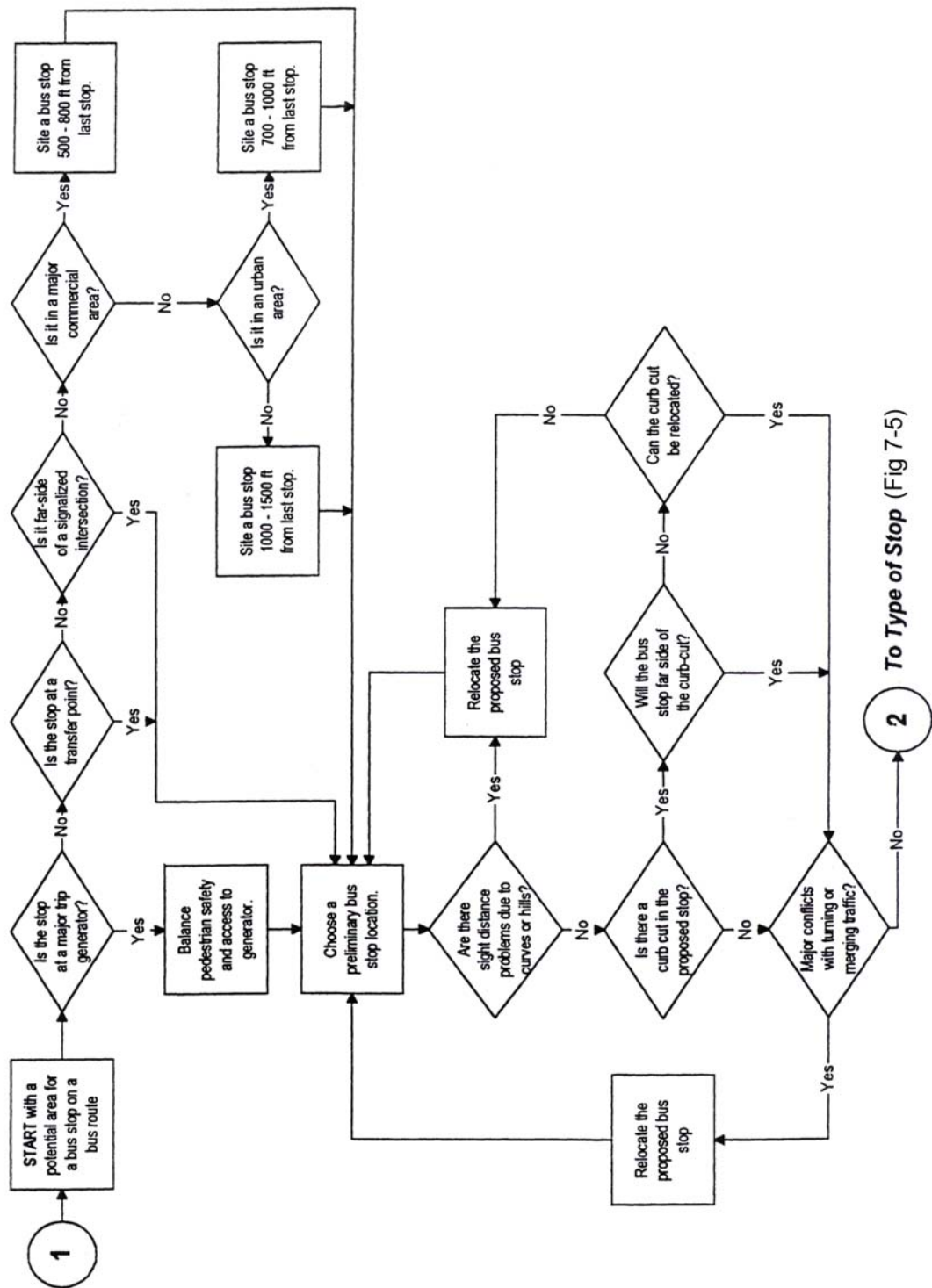

FIGURE 7-4 BUS STOP LOCATION FLOWCHART

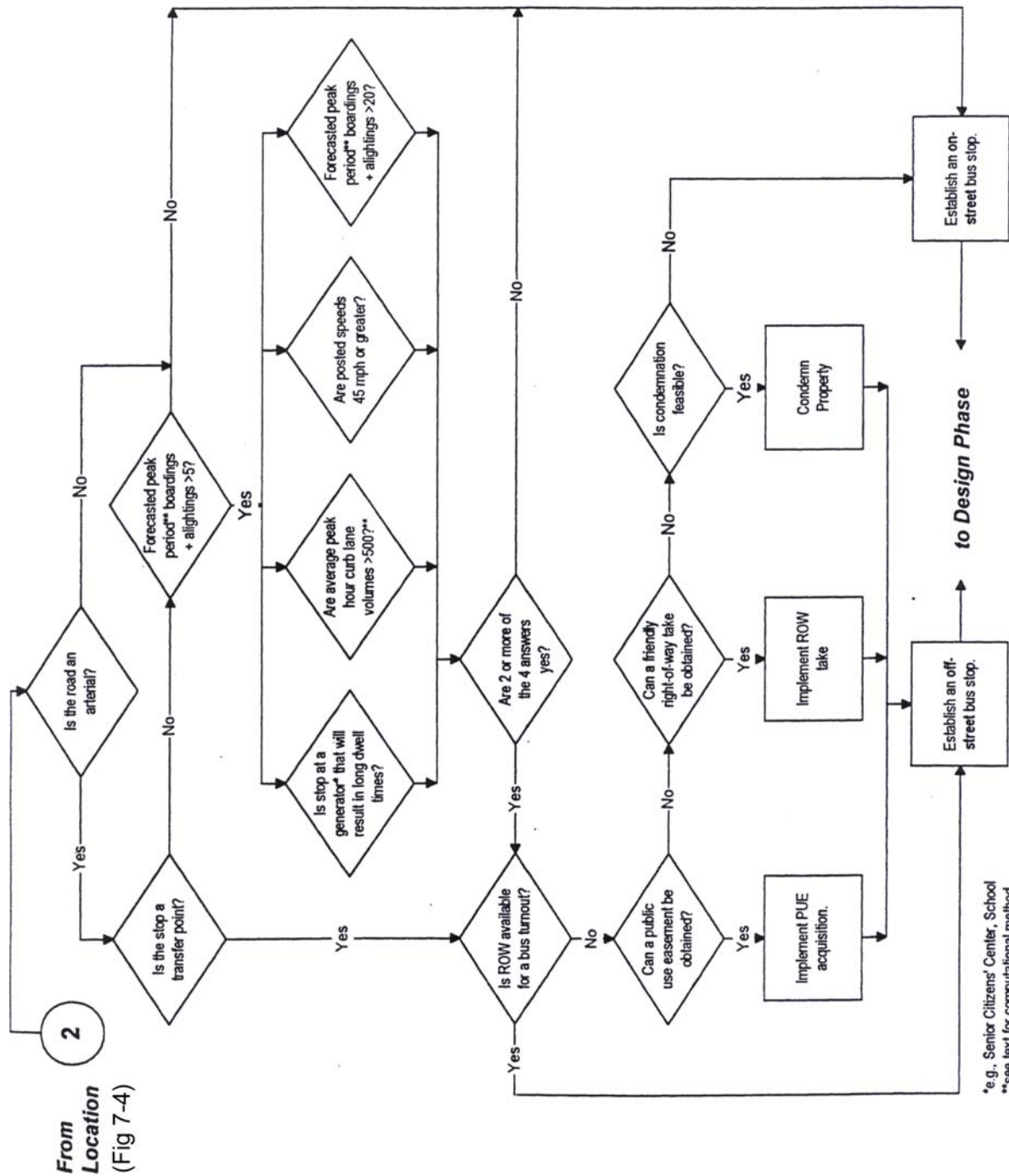

FIGURE 7-5 BUS STOP TYPE FLOWCHART

Step 2: Stops at Transfer Points

The next stops to place are at intersections of streets served by other bus routes. These stops will allow transfers with other buses, which are necessary to provide connections to areas of the community that have no direct routing from a rider's origin. Hassle-free transfers are an important element of a successful transit system. The maximum walking distance between two bus stops serving connecting routes should be no more than 300 feet.

Step 3: Stops at Signalized Intersections

The next category of stops to establish includes those at signalized intersections. Whether on or off-street, stops at the far-side (Figure 7-10) of signalized intersections can operate conveniently for both auto and transit users. Buses can use the gaps in the stream of traffic created by the signal to pickup and discharge passengers and to re-enter traffic.

Step 4: Intermediate Stops

Once stops have been placed at transfer points, major generators and signalized intersections, additional stops are added to complete the set of stops for the route or street. A standard in the transit industry suggests that most riders will not want to walk farther than one quarter-mile to a bus stop. The additional stops for areas of low to moderate passenger demand should be established by applying standard bus stop spacing criteria.

Bus stop spacing should be related to ridership density; stops should be close together in the major commercial districts and farther apart in the outlying areas. Ideally, stops should be as far apart as possible without adversely affecting passenger convenience. The use of ranges for three levels of density is recommended for Anchorage. A breakdown of the Anchorage and Eagle River areas into major commercial districts, urban and rural areas is shown in Figures 7-6 and 7-7. The recommended ranges for bus stop spacing are as follows:

Major Commercial District – 500 to 800 feet

Urban – 700 to 1,000 feet

Rural – 1,000 to 1,500 feet

In rural areas, consideration should be given to how far a person must walk to get to the street with bus service. For areas where much of the development is off the road, stops should be closer than where all development occurs on the road.

Stops on both sides of a two-way street should be paired up whenever possible to provide passengers with boarding and alighting points near one another.

3. Refine Bus Stop Locations

Generally, bus stops should be located after (far-side of) an intersection to facilitate bus and traffic operations. However, far-side stops are occasionally impractical or conflict with existing commercial development. Long blocks and arterials with long distances between intersecting streets also require mid-block stops. On rare occasions, land use, bus routing or other factors will dictate the use of a near-side stop.

Other specific attributes of the preliminary location should be reviewed. Are there sight distance problems due to curves or hills? If the bus driver cannot see to the rear a sufficient distance to safely reenter traffic, or following vehicles cannot see the stopped bus in time to safely stop or merge left, the proposed stop should be relocated. Driveway curb cuts should generally be avoided, with the stop placed far-side of the driveway. If necessary, they can be placed in the entrance taper or the first part of the bay of a turnout (see also Section 7.4 B.2 b., below).

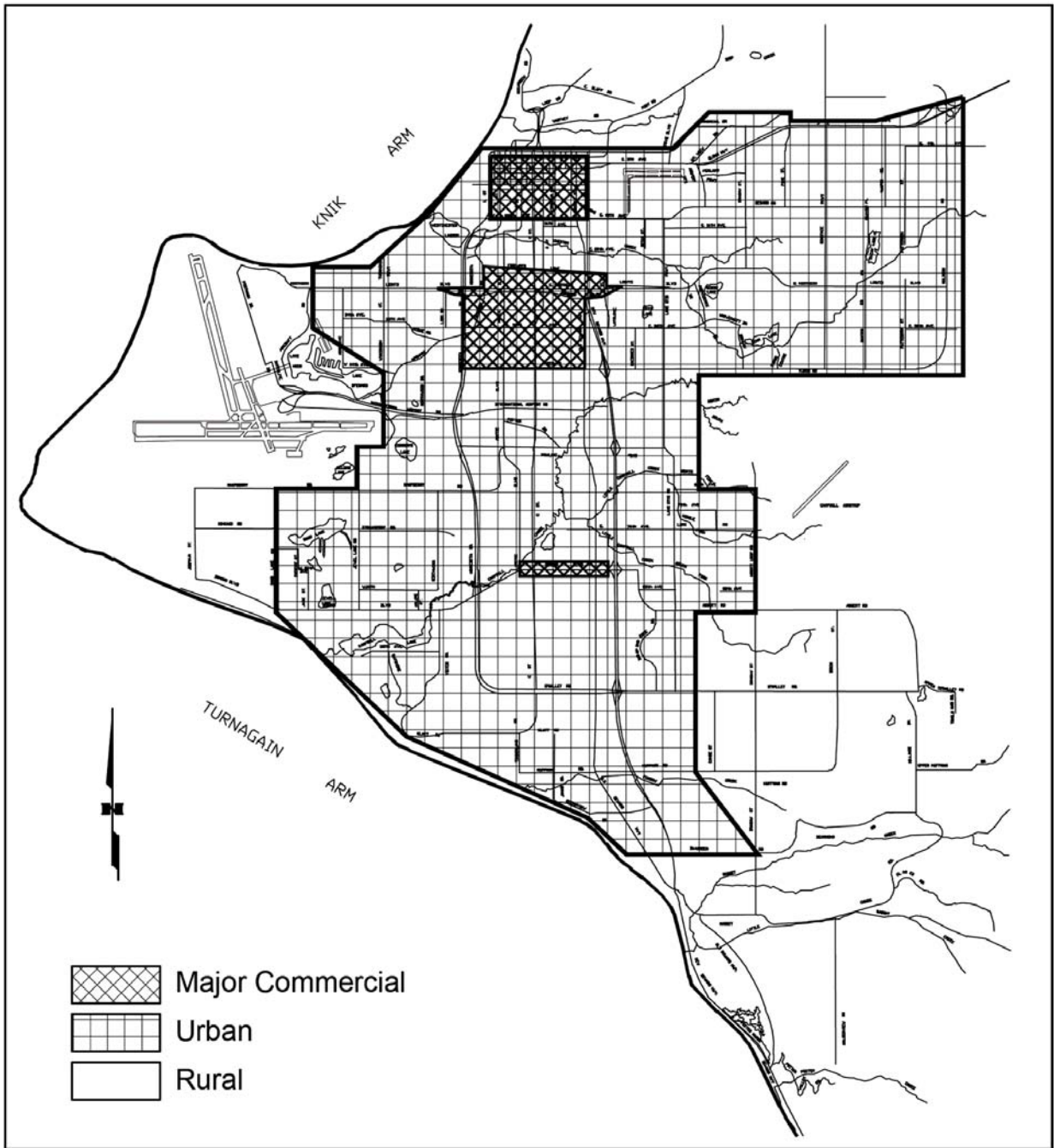

Bus Stop Spacing Criteria - Anchorage

Anchorage Transit Design Guidelines

FIGURE 7-6 BUS STOP SPACING CRITERIA - ANCHORAGE

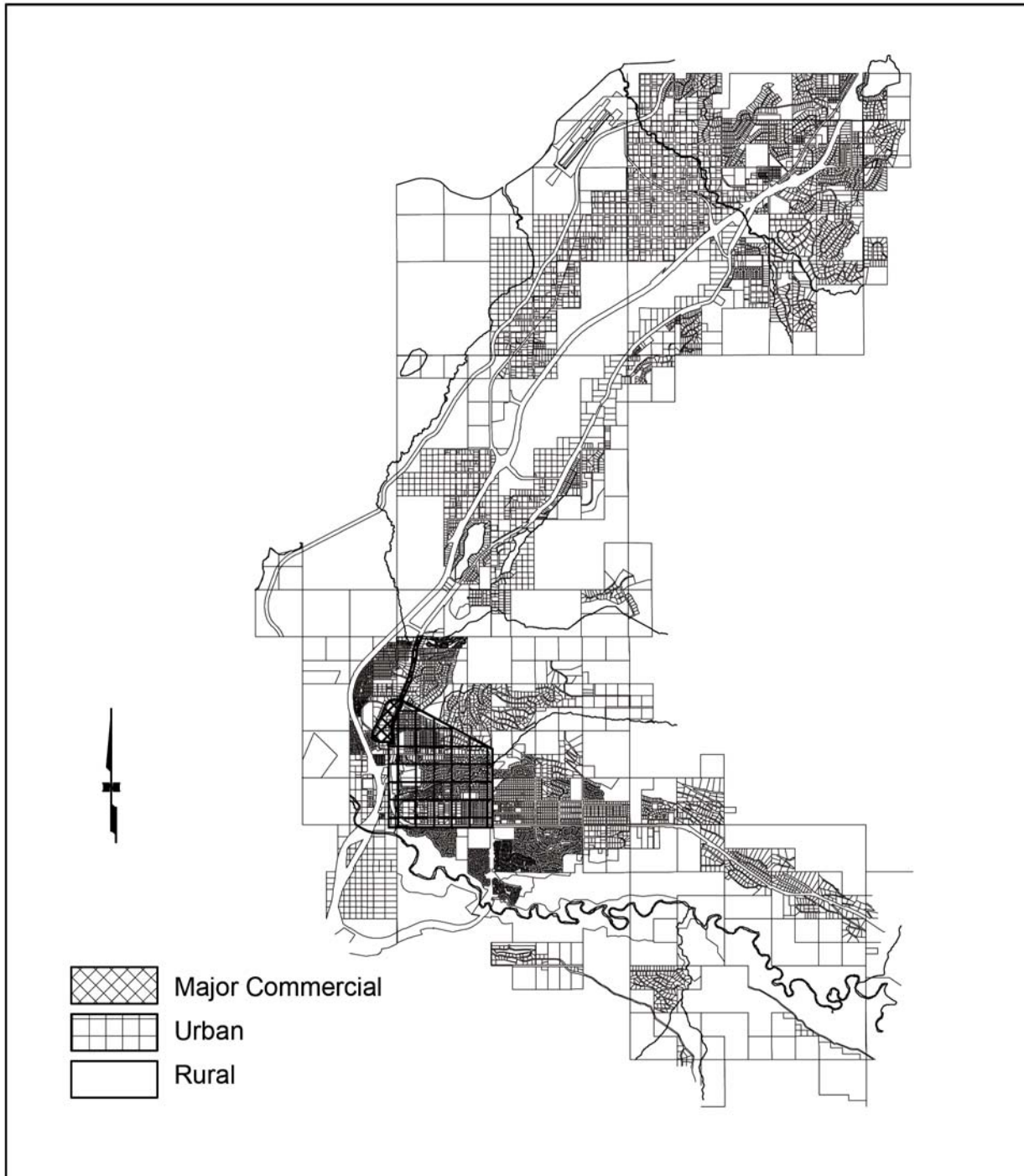

Bus Stop Spacing Criteria - Eagle River

Anchorage Transit Design Guidelines

FIGURE 7-7 BUS STOP SPACING CRITERIA – EAGLE RIVER

The following criteria, advantages and disadvantages for far-side, near-side and mid-block stops are guidelines for refining stop locations:

a) Far-Side Stops

A far-side stop is one which is located immediately after an intersection, defined to include major commercial driveways.

Conditions where far-side stops are recommended:

- At intersections controlled by signals, stop or yield signs.
- The traffic is heavier on the approach side than on the departure side of an intersection.
- The intersecting street is a one way street with traffic moving from left to right (when viewed as one approaches the intersection).
- At intersections where heavy left or right turns occur.
- At intersections where the bus route and heavy traffic movements diverge.

Advantages of far-side bus stops:

- Reduced conflicts between right turning vehicles and stopped buses.
- Additional intersection capacity is provided by making the approach curb lane available for traffic.
- Sight-distance deficiencies created by buses stopped near-side of the intersection are eliminated.
- Pedestrian crossing at rear of the bus is encouraged; in front of the bus discouraged.
- Shorter maneuvering distances for the buses to enter and leave moving traffic are required.

- Increased ease and speed for bus reentering traffic stream during heavy traffic, as a result of platooning of traffic at signalized intersections.

Disadvantages of far-side bus stops:

- Intersections may be blocked if other vehicles park illegally in the bus stop, thereby obstructing buses and causing traffic to back up across the intersection.
- A bus standing at a far side stop may obscure sight distance to the right of a driver entering the intersection from the right.
- Where the bus stop is too short for occasional heavy demand (i.e., multiple buses stopping at the same time), the overflow may obstruct the cross street.

b) Near-Side Stops

A near-side stop is one which is located immediately before an intersection, including major commercial driveways.

Conditions where near-side stops are recommended:

- Traffic is heavier on the departure side than on the approach side of the intersection.
- The cross street is a one-way street where traffic flows from right to left.
- Where the bus route turns right, if curb space is critical, a near-side stop should be established before the turn.
- At intersections controlled by signals or stop or yield signs, when transit operations are more critical than traffic or parking.

Advantages of near-side bus stops:

- Create a minimum of interference at locations where traffic is heavier on the far side than on the approach side of an intersection.

- Passengers generally board buses close to a crosswalk, which minimizes walking distance.

Disadvantages of near-side bus stops:

- Heavy vehicular right turns can cause conflicts, especially where a vehicle makes a right turn from the left of a stopped bus.
- Buses may obscure stop signs, traffic signals, or other control devices as well as pedestrians crossing in the front of the bus.
- A bus standing at a near-side stop diminishes the sight distance of a driver entering the intersection from the right.
- Where the bus stop is too short for occasional heavy demand (multiple buses), the overflow may obstruct the traffic lane.
- The bus reentering traffic flow after stopping often must wait through several light cycles as vehicles trap the bus in the zone.
- Lengthy separate right turn lanes (pockets) cause the bus stop to be located too far from the intersection.

c) Mid-Block Stops

A mid-block stop is one which is located 300 feet or more beyond or before an intersection, including major commercial driveways.

It should be noted that in the case of arterials with long stretches between signalized intersections, mid-block stops present a hazard to the bus rider who often must cross the road on the way from the trip origin or to his or her destination. A raised median can lessen the hazard, allowing the pedestrian to cross half the road at a time. In cases in which a particularly attractive major trip generator exists mid-block, a signalized crosswalk or pedestrian overpass may be warranted.

Conditions under which mid block stops are recommended:

- Traffic or physical street characteristics prohibit a near or far side stop next to an intersection.
- Large bus passenger generators exist, and heavy ridership makes the location desirable.
- Blocks are exceptionally long and allow adequate distance for the bus to merge into a left-turn lane, if required.
- A median island exists in the roadway or space for construction of a median island is available.

Advantages of mid-block bus stops:

- Buses create a minimum of interference with sight distance of both vehicles and pedestrians.
- Waiting passengers assemble at less crowded sections of the sidewalk.

Disadvantages of mid block bus stops:

- The removal of considerable curb parking may be required.
- Patrons coming from a cross street may have to walk farther to board the bus.
- Pedestrian jaywalking is more prevalent, thereby increasing vehicular friction, congestion and accident potential.

4. Controlled Access Roads

Freeway bus stops should only be provided at interchanges. They may be placed on either the on-ramp (desirable) or the off-ramp if the bus will not be turning onto the local street network. The bus turnout location and design should meet the requirements for turnouts on arterial facilities. Turnouts are difficult to provide effectively within cloverleaf or directional-type interchanges and should be omitted or located on the frontage road or cross street beyond the limits of the interchange.

Under special circumstances bus stops may be provided on freeways. This type of bus stop must be constructed so that the deceleration, standing, and acceleration of buses occur on pavement areas clear of, and separated from, the through traffic lanes. Costly features such as speed change lanes and pedestrian overpass facilities are required. The decision about whether to construct these facilities must be based on a cost analysis that compares all benefits with the cost to construct and maintain.

5. Roundabouts

Transit considerations at a roundabout are similar to those at a conventional intersection. If the roundabout has been designed using the appropriate design vehicle, a bus should have no physical difficulty negotiating the intersection. To minimize passenger discomfort, if the roundabout is on a bus route, it is preferable that scheduled buses are not required to use a truck apron if present. Bus stops should be located carefully to minimize the probability of vehicle queues spilling back into the circulatory roadway. This typically means that bus stops located on the far side of the intersection need to have pullouts or be further downstream than the splitter island.

Bus stops situated on an entrance leg should be positioned 50 feet or greater before the splitter island and crosswalk.

Pedestrian access routes to transit should be designed for safety, comfort, and convenience. If demand is significant, such as near a transit/transfer facility, pedestrian crossing capacity should be accounted for.

7.3 C Bus Stop Type – On-Street or Off-Street?

This decision depends on the functional classification of the road, anticipated transit ridership, traffic volume and speed, and other factors. It is normal practice to have buses stop in the traveled way on residential streets, collectors and some minor arterials. In addition, buses will normally stop on-street (in the

parking lane) in the Central Business District (CBD). Typical on-street stops are in a parking lane, in the travel lane, at curb extensions, or on an improved shoulder. On major arterials and some minor arterials, many stops are located off-street in turnouts.

The design of a bus stop on a major arterial is often the most difficult case, because the tradeoffs between general vehicular traffic and transit are difficult to predict and quantify. Lack of quick reentry into the traffic stream from a turnout will, especially if repeated often; increase the transit trip time and the disincentive to ride the bus. However, stopping in the through lane may reduce the roadway level-of-service (LOS) and may precipitate rear-end accidents. Therefore, the decision to place a bus stop off-street in a turnout should be made carefully. Cumulatively, the decisions will affect the ability of the roadway and transit to move people safely and quickly. This section contains a decision-making process that will help the planner or engineer make consistent decisions. The sequence is diagrammed in Figure 7-5.

1. Sequence of Decisions

Step 1: Is the road an arterial?

If the answer is no, put the stop on-street. If yes, go on to step 2. Turnouts are not necessary on collector level or lower functional classifications.

Step 2: Is the stop a transfer point for connecting bus routes?

If the answer is yes, go to step 5. If no, proceed to step 3.

Far-side bus turnouts should be constructed where bus routes intersect. This allows a bus to wait for transferring passengers safely out of the curbside travel lane, and to use the signal red phase to reenter the travel lane.

Step 3: Is daily stop use expected to average more than 5 during both peak periods?

If the answer is no, build an on-street stop. If yes, go on to step 4.

Stop use is the sum of average boardings and alightings. Peak periods are defined as 6:30-8:30 a.m. and 4:00-6:00 p.m. The People Mover Planning Division can provide current boardings and alightings and predict whether the average is likely to increase or decrease in the future due to changes in nearby land use. Given that property must often be acquired to build turnouts, construction can be expensive. It is generally not cost-effective to design and construct an off-street stop that is expected to handle very few riders.

Step 4: Does the site meet two of the four minimum warrants for an off street stop?

The warrants are:

- a) Peak hour traffic volumes greater than 500 in the curb lane; (Curb lane volume is calculated by dividing the directional volume by the number of lanes (unless actual counts by lane are available). Whether current volumes or design year average daily traffic (ADT) are used is dependent on the type of project. New facility construction or major reconstruction should consistently use design year ADT.)
- b) Posted operating speeds 45 mph or greater;
- c) Longer than average bus dwell times, as a result of the stop serving a generator such as a senior citizen's center, school or similar site.
- d) Projected average daily stop use greater than 20 during both peak periods.

If the answer is no, establish an on-street stop. If yes, proceed to step 5.

Rather than asking the planner or designer to estimate bus dwell times for a stop that may not

currently be in use, consideration of the main use served by the stop is recommended instead. Most stops in Anchorage do not produce dwell times greater than ten seconds, unless the stop serves a land use with a combination of high ridership and a preponderance of young or elderly or people with disabilities. Longer than average dwell times are often encountered at stops serving schools, senior citizen housing or activity centers, and workplaces/centers for people with disabilities. Stops that frequently serve passengers in wheelchairs should also be included.

Step 5: Is there sufficient right of way for an off-street stop?

If yes, establish an off-street stop. If no, consider property acquisition, and go on to step 6.

Step 6: Can a public use easement be obtained?

If yes, secure the easement and establish an off-street stop. If no, proceed to step 7 and consider a friendly right-of-way acquisition.

Step 7: Can a friendly right-of-way take be obtained?

If yes, acquire the property and establish an off-street stop. If no, proceed to step 8 and consider condemnation of the property.

Step 8: Is condemnation feasible?

If yes, condemn the property and establish the off-street stop. If no, establish an on-street stop.

2. Other Issues to Consider

- a) If real estate acquisition is necessary, will it make the affected property(s) a non-conforming land use? If so, can a variance be obtained? If a variance cannot be obtained, will the entire parcel have to be purchased?

Strip development often results in parking spaces constructed right up to the public right-of-way. The installation of a bus turnout at such locations can be very expensive. Besides purchasing sufficient

developed property to build the turnout, it sometimes becomes necessary to purchase the entire lot, because the acquisition puts the development into a non conforming status or creates a site that is no longer economically viable. It may be more appropriate to install an on street stop in such cases, and avoid the need for expensive property acquisition. In addition, the already significant turbulence in traffic flow created by many turning movements to and from commercial sites means the occasional stopped bus is a marginal contributor to auto user delay.

Strip development often results in parking spaces constructed right up to the public right-of-way. The installation of a bus turnout at such locations can be very expensive. Besides purchasing sufficient developed property to build the turnout, it sometimes becomes necessary to purchase the entire lot, because the acquisition puts the development into a non conforming status or creates a site that is no longer economically viable. It may be more appropriate to install an on street stop in such cases, and avoid the need for expensive property acquisition. In addition, the already significant turbulence in traffic flow created by many turning movements to and from commercial sites means the occasional stopped bus is a marginal contributor to auto user delay.

- b) Will an off-street stop severely impact transit operations? Would a bus stopped in the turnout regularly have to wait more than 30 seconds to reenter traffic flow?

If the answer to one or both questions is yes, consider whether the stop should be relocated or made into an on-street bus stop.

END OF SECTION 7.3

SECTION 7.4 BUS STOP DESIGN

7.4 A Objectives

Bus stops serve as interface points between sidewalk/trail systems, street networks, and transit routes. Consequently, bus stop design should provide access, temporary and permanent storage capacity, and through-traffic bypass capability for vehicles and pedestrians.

7.4 B Design

1. On-Street Bus Stops

Table 7-1 below summarizes minimum on-street bus stop requirements.

Figure 7-10 presents desirable on-street bus stop layouts for far-side, near-side, and mid-block locations. The stop lengths shown for each

location indicate the length of roadway which should be signed and/or painted for No Parking and cleared of any landscaping, street hardware, signs, etc. that may interfere with the loading and unloading of passengers and other transit-related operations.

On-Street Bus Stops assume one of three conditions:

Condition 1: The bus will dwell in a through traffic lane;

Condition 2: There is a combined through lane + shoulder + parking/bike lane width of 20 feet available for the bus to clear the travel lane during stops.

Condition 3: There is a Curb Extension which utilizes less curb space than pullouts.

TABLE 7-1 MINIMUM ON-STREET BUS STOP REQUIREMENTS

Design Condition	Minimum Entry Length	Bay Length	Minimum Departure Length
Mid-Block Stop	40 feet(60' desirable)	40 feet plus 50 ft. per additional bus	30 feet
Far Side Stop	10 feet ⁽¹⁾	40 feet plus 50 ft. per additional bus	30 feet
Far Side Stop (after bus turn from side street)	60 feet ⁽²⁾	40 feet plus 50 ft. per additional bus	30 feet
Near Side Stop	60 feet ⁽²⁾	40 feet plus 50 ft. per additional bus	0 feet ⁽¹⁾

Notes:
⁽¹⁾Assumes sufficient length in crosswalk, curb return, and side street for entrance/reentry taper.
⁽²⁾Measured from edge of crosswalk or point-of-tangent (PT) of curb return. If the side-street has a free-right turn lane, the entry length should begin at the end of the merge lane taper.

If neither condition applies, a turnout should be designed in accordance with Section 7.4 B.2, Off-Street Turnouts, below.

a) On-Street Bus Stops - Condition 1

For on-street bus stops meeting Condition 1, no roadway improvements are required. Access shall be provided in accordance with section 4 C., Facility Access, below. Where possible, a waiting area and amenities should be provided in accordance with Section 4 D., Bus Stop Amenities, below.

b) On-Street Bus Stops - Condition 2

The design of on-street bus stops under Condition 2 should consider location factors (such as traffic volumes and turning movements—reference Section 7.3 above), traffic control, parking, intersection characteristics, and pedestrian movements. Each on-street bus stop should incorporate an entrance length, a bay length, and a departure length (presented in Figure 7-10). Desirable entrance lengths are 60 feet, and minimum lengths shall be 40 feet. Bay lengths shall be 40 feet plus 50 feet for each additional bus scheduled to dwell simultaneously at the stop. Departure lengths shall be a minimum of 30 feet. Note that these lengths are not identical to comparable turnout dimensions. Curb corresponding to the entrance, bay and departure segments of the stop shall be painted red.

For bus stops on the near side of intersections, the width of the crosswalk, curb return and cross-street should provide sufficient reentry space. For bus stops on the far side of intersections, the intersection area behind the crosswalk may be used for the entry taper.

Access to the stop shall be provided in accordance with section 7.4 C., Facility Access. Where possible, a waiting area and amenities for turnouts should be provided in accordance with section 7.4 D., Bus Stop Amenities.

c) On-Street Bus Stops – Condition 3 - Curb Extensions

On streets with parking, near-side and far-side bus stops also benefit from curb extensions, so

passengers can board or dismount the bus directly without stepping onto the street; this also makes it easier to meet ADA requirements (the bus pulls up right next to the curb) (Figure 7-8).

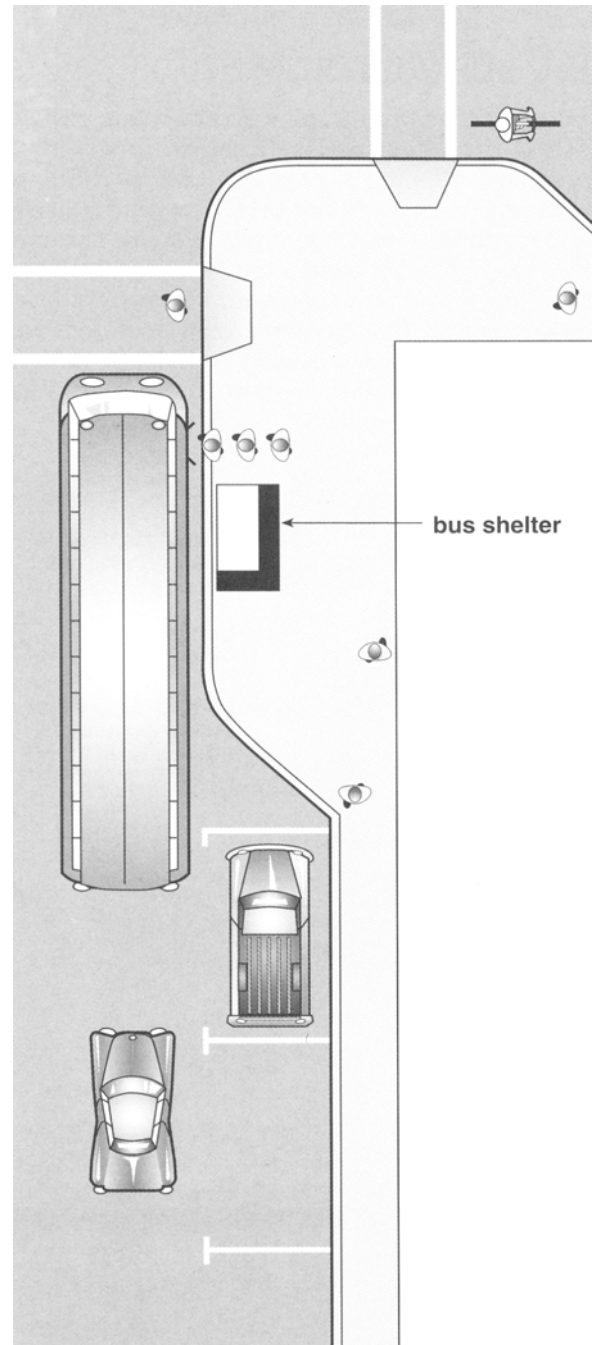

FIGURE 7-8 NEAR-AND FAR-SIDE CURB EXTENSION AT INTERSECTION



FIGURE 7-9 BUS STOP WITH CURB EXTENSION

In urban areas where on-street parking is at a premium, bus stops with curb extensions can be installed (see Figure 7-9). The curb extension stops utilize less curb space than pullouts and minimize obstructions to pedestrian traffic—essentially an on-street stop that maintains available parking and pedestrian flow.

The curb extension tapers should be sharp enough to discourage additional parking, but shallow enough to easily plow snow.

2. Off-Street Turnouts

Off-street turnouts are widened sections of roadway designed for buses to pull out of the traffic stream (see Figure 7-11). Consequently, they should be considered integral to the roadway and maintain its functional elements. The following discussion presents standards for the geometric layout and typical sections of turnouts. Access to the turnout shall be provided in accordance with Section 7.4 C., Facility Access, below. Where possible, a waiting area and amenities for passengers should be provided in accordance with Section 7.4 D., Bus Stop Amenities, below.

a) Geometric Lay-Out

Entrance and departure lengths shall be developed by tapering the roadway limits (Figure 7-11). Entrance tapers shall have a desirable 6:1 and minimum 5:1 longitudinal to transverse ratio. When the bus stop is on the far side of an intersection, the intersection may be used as the entry to the stop. Desirable bay lengths shall be 80 feet, with a minimum of 50 feet. Also, a minimum of 50 feet

shall be provided for each additional bus scheduled to dwell simultaneously at the stop. Departure tapers shall have a desirable 6:1 and minimum 3:1 longitudinal to transverse ratio. Where the turnout is on the near side of an intersection, the width of the cross street is usually great enough to provide the necessary merging space

Longer bus turnouts speed bus maneuvers and lessen interference with through traffic. Figure 7-11 presents a typical geometric layout for a bus turnout. If right-of-way or other constraints do not allow construction of the desirable turnout dimensions, the bay length should be modified first, followed by the departure taper, and lastly the entrance taper.

Driveway access should generally be avoided. However, where site conditions demand, a bus turnout may be located such that the curb cut is placed in the approach taper, or in the approach end of the central portion of the turnout. In such cases the bay shall be lengthened by an amount equal to the width of the curb cut. The curb cut shall not be placed in the departure taper.

Turnouts should not be located where there are potential rear-sight distance problems. Generally, turnouts shall not be located on horizontal curves to the right.

b) Typical Cross-Section

Bus turnouts should extend the typical section of the adjoining roadway, including curb and gutter treatment, cross-slope, drainage pattern, and structural fill. However, because traffic volumes in the turnout will be significantly less than the roadway, a depth of pavement of 3 inches is permissible. On roadways with flat grades, protraction of the cross slope across the bay width may disrupt drainage patterns both on the roadway and adjacent properties. The engineer should design the vertical alignment to maintain minimum grades in the gutter or provide appropriate inlet treatment. Particular attention should be paid to pullout drainage with roadway flow grades of .5% or less. Typically this creates ponding in the pullouts, problematic for passengers waiting at the stop due to water spray and sidewalk icing (see Figure 7-11, Note 5).

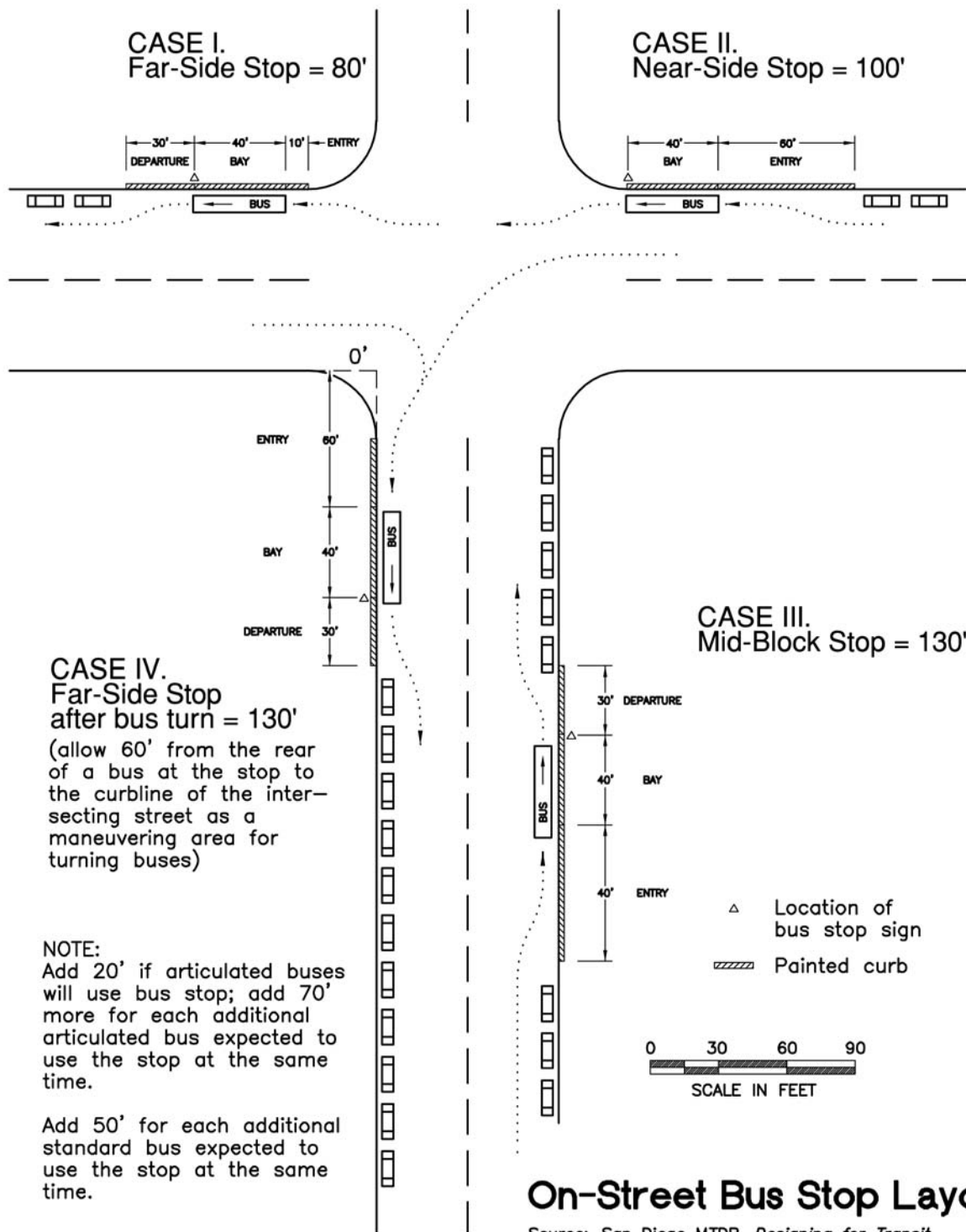

CASE IV.
 Far-Side Stop
 after bus turn = 130'
 (allow 60' from the rear
 of a bus at the stop to
 the curbline of the inter-
 secting street as a
 maneuvering area for
 turning buses)

NOTE:
 Add 20' if articulated buses
 will use bus stop; add 70'
 more for each additional
 articulated bus expected to
 use the stop at the same
 time.

Add 50' for each additional
 standard bus expected to
 use the stop at the same
 time.

On-Street Bus Stop Layouts

Source: San Diego MTDB, *Designing for Transit*

Anchorage Transit Design Guidelines

FIGURE 7-10 ON-STREET BUS STOP LAYOUTS

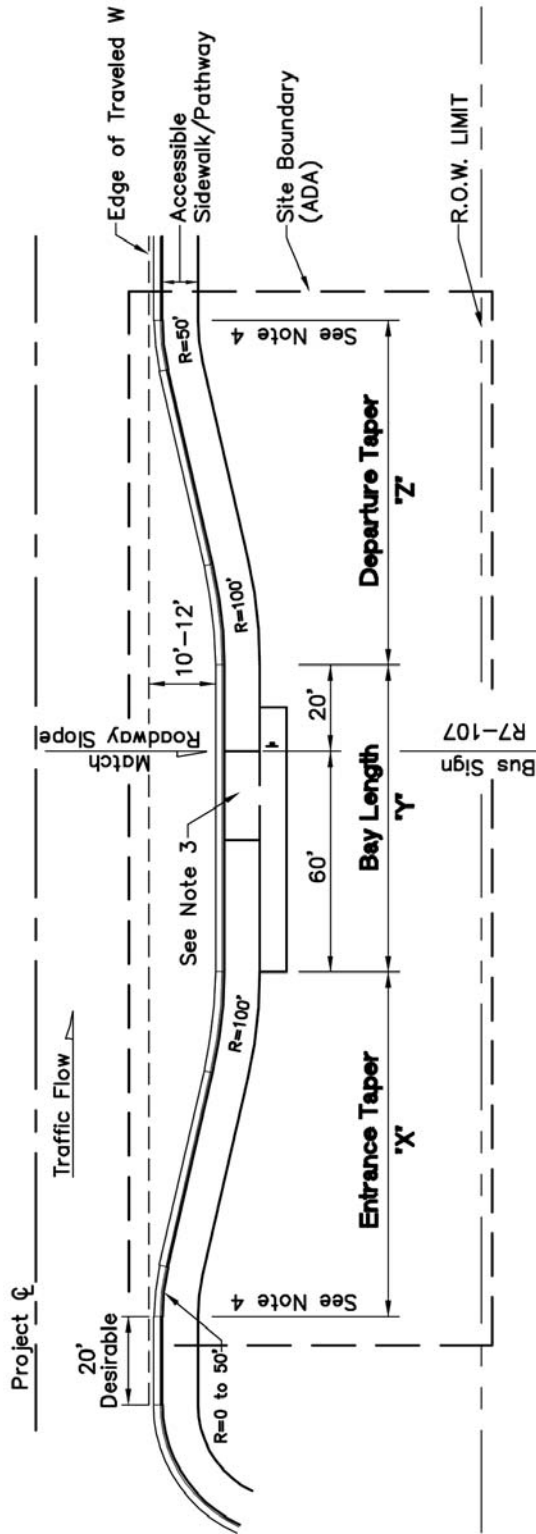

BUS TURNOUT DIMENSIONS

Pullout Type	Bay Width 10' Min.	Entrance Taper 'X'	Rate	Bay Length 'Y'	Departure Taper 'Z'	Rate	Description
A	12'	60'	6:1	80'	60'	6:1	Urban Road, No Shoulder
B	12'	60'	6:1	50' Min.	30'	6:1	Urban Road, No Shoulder
C	12'	50'	6:1	50' Min.	30' Min.	3:1	Urban Road, No Shoulder
D	12'	50' Min.	6:1	50' Min.	30' Min.	3:1	Urban Road, No Shoulder
E4	12'	48'	6:1	80'	48'	6:1	Urban Road, 4' Shoulder
E6	12'	36'	6:1	80'	36'	6:1	Urban Road, 6' Shoulder
E8	12'	24'	6:1	80'	24'	6:1	Urban Road, 8' Shoulder

Notes:

1. Construct curb angles to the radii shown.
2. Pave approach between bus stop and access when used.
3. All bus turnouts shall have, as a minimum, an 8-foot wide by 30-foot long paved loading area for wheelchair lift operation and disabled user access.
4. Begin bus turnout station based on direction of project stationing.
5. When drainage will not clear pullout, install catch basin or M.O.A. Type III curb and valley gutter system.
6. Type A pullout is the Standard Geometric layout for the typical bus turnout. All other types are modifications based upon location and type of roadway where installed.

**Geometric Layout for
Typical Bus Turnout**
Anchorage Transit Design Guidelines

FIGURE 7-11 GEOMETRIC LAYOUT FOR TYPICAL BUS TURNOUT

7.4 C Facility Access

The location and design of new bus stops shall be accessible to persons with disabilities and provide for safely and fully deploying lifts and ramps on transit vehicles in accordance with the requirements of this section as much as is structurally practicable. It is noted that cost is not a factor in determining structural practicability in new construction.

For the rehabilitation or improvement of existing bus stops, the provision of access to persons with disabilities and adequate area for the safe deployment of lifts and ramps is required as much as is structurally practicable.

Where the engineer believes that implementation of the requirements of this section is not structurally practicable, they shall develop written documentation of the rationale for her/his judgment.

1. Bus Stop Pads

Bus stop pads that provide a minimum clear space for deploying a lift and ramp from a transit vehicle shall be developed for all bus stops. Where feasible, the pad shall be a paved area with the following minimum dimensions:

Thirty (30.0) feet long, as measured parallel to the roadway, and 8.0 feet wide as measured perpendicular from the back of curb or roadway shoulder. For boarding pads that will have amenities such as benches, trash receptacles, and lights, a width of 10 feet is desirable. For bus stop locations where this much space is not available, the clear space shall be a minimum of 5 feet by 8 feet at the bus door (Figure 7-12).

Assuming the bus dwells with its front approximately even with the transit sign, the pad should be placed at the front door of the bus where the lifts and ramps are deployed. A pad at the rear door location is also desirable. Optimally the boarding pad should extend from the front door to the rear door of the bus.

2. Accessible Routes

Bus stops shall be connected with an accessible route to all streets, sidewalks, and/or trails within the

site boundary. The site boundary is considered to be defined by the beginning and end of the bus stop, the adjacent street, and the right-of-way line for the street segment containing the bus stop. Accessible routes shall comply with all federal ADA guidelines, including but not limited to, width, clearances, surfaces, grades, and cross slopes. Exterior accessible routes may include parking access aisles, curb ramps, crosswalks at vehicular ways, walks, ramps and lifts. Figure 7-11 depicts a typical minimum site boundary for a bus turnout. Where a bus stop serves as a transfer point, the site boundary and an accessible route shall extend to the connecting route bus stops. Where a bus stop is the closest stop to an intersection, major generator or other private development, it is necessary to extend the site boundary and an accessible route to the intersection, and desirable to extend both boundary and route to the generator or development. In the case of a mid-block stop with no adjacent sidewalk or trail, it is desirable to provide an accessible route to the nearest intersection or signal-protected crosswalk.

a) Width of Walks and Ramps

Accessible routes should be at least 5 feet wide. A minimum width of 3 feet is legally acceptable if 5-foot by 5-foot passing spaces are provided at intervals of 200 feet or less. Use of 3-foot wide walks in Anchorage and environs is discouraged, however, as mechanized snow removal on narrow sidewalks is impracticable.

b) Side and Vertical Clearance

Accessible routes must be completely clear of any objects protruding from the surface or from the sides that narrow the pathway such as fire hydrants, parking meters, sign posts, benches, landscaping, etc. A minimum clear head room of 80 inches shall be maintained on accessible pathways.

c) Surfacing

Surfaces along accessible routes shall be stable, firm and slip resistant. It is recommended that routes be paved with either 4-inch thick Portland Cement Concrete or 2-inch asphalt concrete pavement. An appropriate foundation shall be provided for the surfacing.

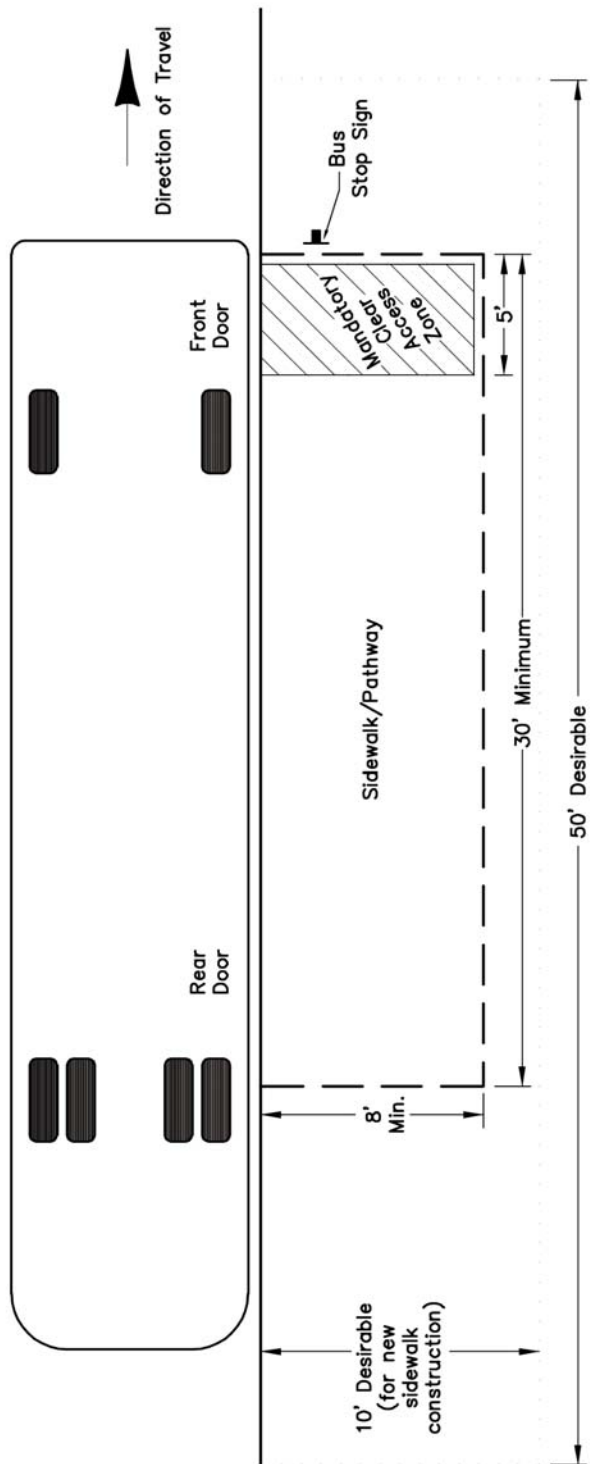

- Notes:**
1. Pad to be constructed of 4" P.C.C. or 2" A.C. pavement.
 2. Pad cross-slope along road to match curb or shoulder.
 3. Pad cross-slope perpendicular to road to be 2% max. and drained toward gutter or ditch.

- MINIMUM BUS STOP PAD DIMENSIONS (8' x 30')
- - - - - DESIRABLE BUS STOP PAD DIMENSIONS (10' x 50')
- CLEAR ZONE NECESSARY FOR WHEELCHAIR LIFT AND RAMP OPERATION

Geometric Layout for Typical Bus Stop Pad

Source: DOT/PF Bus Turnout Details Sheet

Anchorage Transit Design Guidelines

FIGURE 7-12 GEOMETRIC LAYOUT FOR TYPICAL BUS STOP PAD

d) Grades, Changes in Level, and Cross-slopes

Any part of an accessible route with a slope greater than 5% shall be considered a ramp and comply with subsection 3, Ramps, below. Changes in level greater than ¼-inch shall be accommodated in accordance with subsection 3, Ramps, below. The maximum permissible cross-slope is 2%.

e) Gratings

Gratings should not be placed in accessible routes. If gratings must be located in the route, they shall have openings no greater than ½-inch wide in one direction. If gratings have elongated openings, they shall be placed so that the long dimension is perpendicular to the direction of travel.

3. Ramps

Segments of accessible routes with grades greater than 5% or changes in level greater than ¼-inch shall be designed in accordance with this section. All other accessible route requirements shall be applied to ramps.

a) Grades

The maximum slope for any segment of a ramp is 8.3%. However, where site infeasibility precludes a slope of 8.3%, the least possible running slope shall be provided. The maximum rise for any segment of an accessible route with a grade greater than 5% is 30 inches. All ramps must comply with ADA criteria. All ramps are required to be equipped with a detectable warning system. If possible, all slopes, cross slopes, and grades must be adhered to. A landing shall be constructed on the ramp after each 30 inches of rise. Minimum landing size shall be 5.0 feet by 5.0 feet.

b) Changes in Level

Any abrupt change in level on a bus stop pad or accessible route greater than ¼-inch but less than ½-inch must be beveled to a slope of no more than 1 inch of rise for 2 inches of run. For this reason, using paving materials such as concrete brick pavers and imprinted Portland concrete cement, particular

attention shall be emphasized with respect to surface tolerances.

Any change in level on a bus stop pad or accessible pathway greater than ½-inch requires a ramp. Curb ramps shall meet the requirements of ADAAG.

7.4 D Bus Stop Amenities

1. Waiting Areas

Regardless of the location and type of stop, all new or rebuilt bus stops must provide a bus stop pad as described above in Section 7.4 C. The improved stop should include adequate area and clearance for passenger access to buses, bus stop amenities, and connecting sidewalks and trails. Waiting areas should be removed from the through sidewalk or trail. Figure 7-13 depicts a fully-developed waiting area and the desirable location of amenities.

2. Benches

a) Design

The Department has a specified bench that is installed at its facilities. The bench standardizes and provides recognition of public transportation facilities. Benches are installed at stops based upon the average number of boardings and/or if the stop provides service for senior citizens or people with disabilities.

The Department may provide benches for the project and designers should contact the Director of the Department for arrangements and/or equipment specifications.

b) Placement

Benches should be placed no closer than five feet from the curb to avoid injuries to persons waiting at the benches by the opening of bus doors, and to allow passengers to pass people sitting on the bench.

At least 60 inches of clearance for wheelchairs should be provided on either the front or backside of the bench (see Figure 7-13). Seating should be placed no closer than five feet and no further than 15 feet from a bus stop sign post.

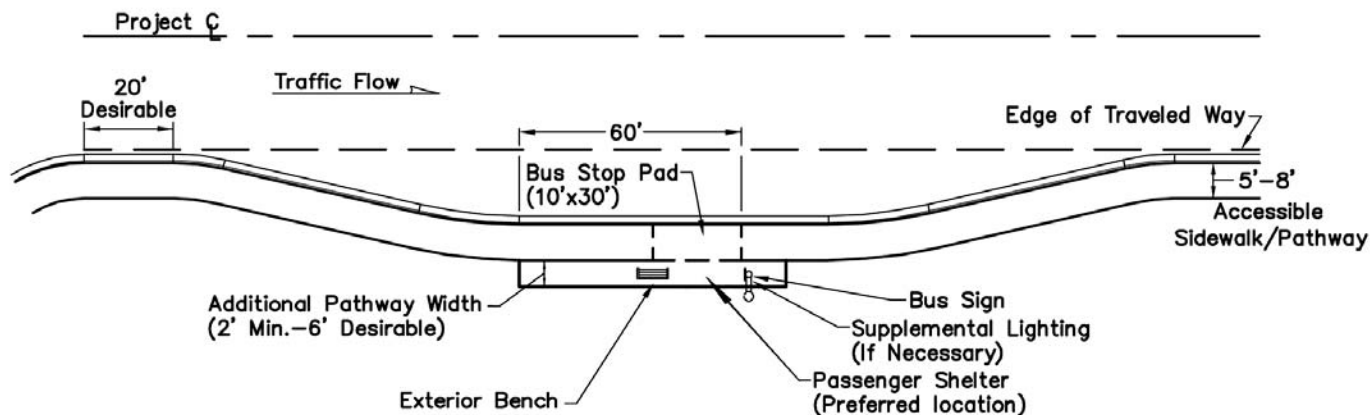

Notes

1. Pathway, shelter and bench pad to be paved with A.C. or P.C.C.
2. Shelter and/or bench may be relocated; maintain 5-ft width for pathway and 8-ft min. width for the bus stop pad.
3. Supplemental illumination to be placed near-side of shelter, and/or bench, and/or at sign location.
4. Optional amenities: pay phone, transit information sign/kiosk.
5. If sidewalk/trail is separated from the curb, signs, benches, and other amenities may be located in the separation area, if accessible pathways and pads are provided. Similarly, pathways with significant bicycle traffic should be routed behind the shelter and pad, in order to avoid conflict with transit passengers.
6. When possible, install light at sign location and mount sign on pole
I.A.W. M.O.A. Standard Detail 70-29.

Fully Developed Bus Stop Waiting Area

Applicable to on-street stops as well as turnouts.

Anchorage Transit Design Guidelines

FIGURE 7- 13 FULLY DEVELOPED BUS STOP WAITING AREA

3. Trash Receptacles

The Department has a specified trash receptacle that is installed at its facilities. If available, the Department may be able to provide trash receptacles for the project. The designer should contact the Director of the Department for arrangements and/or equipment specifications.

4. Shelters

The Department encourages construction of shelters that provide protection from rain, wind and snow for transit passengers.

a) Design

Bus shelter designs shall provide for ready use by individuals in wheelchairs. The following minimum features should be incorporated into a shelter:

- Complete roof
- Optional walls
- Inside bench with outside bench if site conditions allow
- Interior and exterior lighting
- Display area for route and schedule information
- Concrete base

A typical shelter design used in Anchorage is shown in Figure 7-14. A shelter depth of 60 inches is recommended to allow wheel chair users to turn around once inside the shelter. Open-faced shelters are required by ADA to have a minimum clear floor area of 30 inches deep and 48 inches wide. Shelters should be located behind the bus stop boarding area and be set back from back of curb or edge of pavement at least 8.0 feet to leave room for the full bus stop pad. If the shelter cannot be located next to the bus stop pad, an accessible route shall be constructed between the two. Electricity should be provided for illumination of the shelter interior, in accordance with Municipal Code requirements.

Shelters can also be designed into the architectural theme of a building. Shelters integrated into building

facades can vary considerably depending on the purpose and style of the building. There should, however, be at least 30 inches of roof overhang to protect waiting passengers.

b) Location

Bus shelters should be placed at the following locations:

- Any stop serving more than 40 boarding/transferring passengers per day within major commercial areas.
- Any stop serving more than 25 boarding/transferring passengers per day within urban and rural areas.
- Any stop that is a major transfer point between routes.
- Any stop located near schools, senior citizen housing facilities or community recreation centers where large concentrations of the young or the elderly are expected.

c) Other Considerations

Shelters need to be aesthetically and functionally compatible with nearby uses; a shelter should not severely affect an adjacent residence or business. Every effort should be made to minimize potential impacts before proceeding with an installation. Passenger shelters are generally located within the available public right-of-way, on sites that allow for clear and open pedestrian movements. Locations at or near existing street lighting are also preferred.

d) Utilities

Utilities are a consideration for bus stops where it is anticipated that a shelter will be required. If the location is a transfer point and/or abuts a land use expected to generate significant passenger activity then it is likely that a passenger shelter will be installed. A power connection will be required to provide illumination inside the shelter. The field location can often be adjusted to some extent to minimize the power drop and corresponding capital costs.

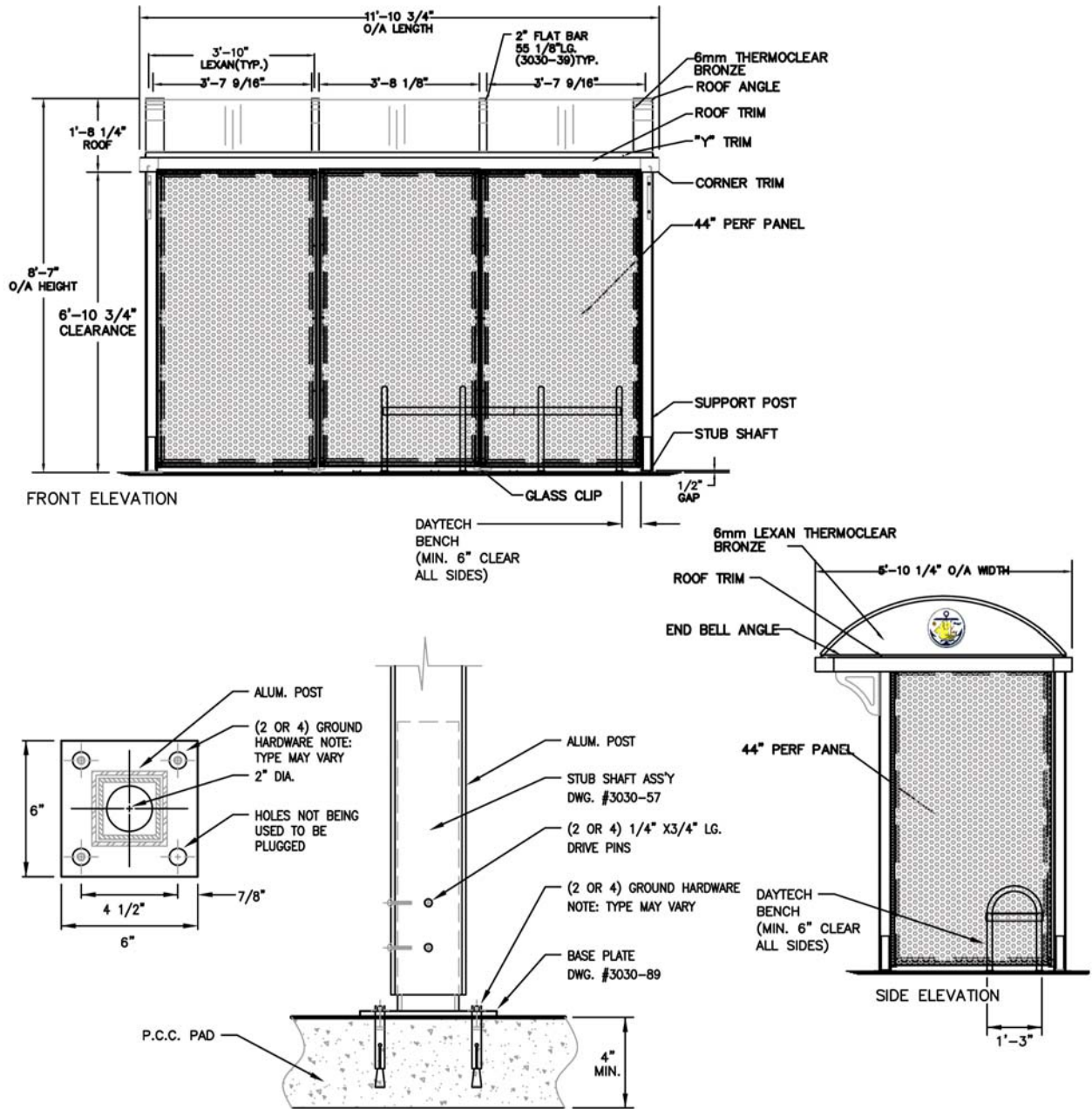

Passenger Shelter
 Daytech Shelter
Anchorage Transit Design Guidelines

FIGURE 7-14 PASSENGER SHELTER

It is sometimes the case where utility poles, power transformers, signal switching boxes, etc., conflict with the location of an off-street bus stop. If the cost of utility relocation is prohibitive, then it may be appropriate to modify the optimal location and/or design

e) Coordination with Property Owners

Coordination with adjacent property owners can sometimes produce more cost-effective bus stop improvements. Examples of benefits include benches integrated into the design of fences or walls, and awnings or building overhangs used as passenger protection. This approach can produce attractive improvements at minimal agency cost.

5. Bus Stop Signs

All bus stops should be conspicuously signed. Unlike most street signage, bus stop signs serve both informational and marketing functions, and are designed to be viewed both by drivers and pedestrians. Signs are intended to be immediately identifiable as transit stops in order to make the system easier to use for existing riders and to attract new users. People Mover bus stop signs are produced by the Municipal Sign Shop.

Regular bus stop signs (Figure 7-15) are placed at all authorized bus stops. Sign placement for bus turnouts should be 60 feet from the end of the entrance taper. Sign placement is generally 80 feet from the intersecting curb line for far-side on-street stops.

Although the bus stop sign may be mounted with a "No Parking" sign, generally, it should be mounted independently of other signage on its own pole. The sign face should be mounted at a 93° to 97° angle to the direction of travel. When a sign must overhang an accessible pathway, it shall be mounted at least 80 inches (6.7 feet) above the ground.

Where applicable, bus stop signs can be mounted on bus stop light poles if the light location is installed at the appropriate sign location. Lighting at bus stops is encouraged. Signs and schedules can be easily read when mounted on the light pole.

Central Business District: Signs should not be closer than 19 inches from back of curb to avoid contact with bus mirrors. Signs shall be located between the curb and the main walking corridor when separated from the curb.

Outside Central Business District: Signs should not be obstructed by trees, buildings or other signs, shall be set back four feet from the curb face, and should face oncoming traffic. If there is a sidewalk or adjacent bike trail, the sign should be placed outside the sidewalk or bike trail, unless the distance is more than 10 feet from the curb line.

6. Public Route and Schedule Information

The People Mover has two types of bus stop route and schedule information signage: schedule information holders and A-frame signs. Schedule information holders are 8.5-inch by 21-inch cast metal units mounted to bus stop sign posts, light poles, or shelter frames. The holders display one to five schedules. A-frame signs are large, 7-foot high displays bolted to sidewalks or special landing pads and display between 3 and 40 schedules. Figure 7-16 contains illustrations of both.

a) Design

A-frame signs are designed to display a variety of transit information, including bus route, numbers, maps and schedule information, transit riding tips, and other information, as appropriate.

Schedule information holders are designed to display a schematic route map and schedule of each route that serves the stop. At stops used by the visually impaired it is also desirable to include an information placard, which would contain the route number, direction (inbound or outbound), and location of the stop printed in Braille.

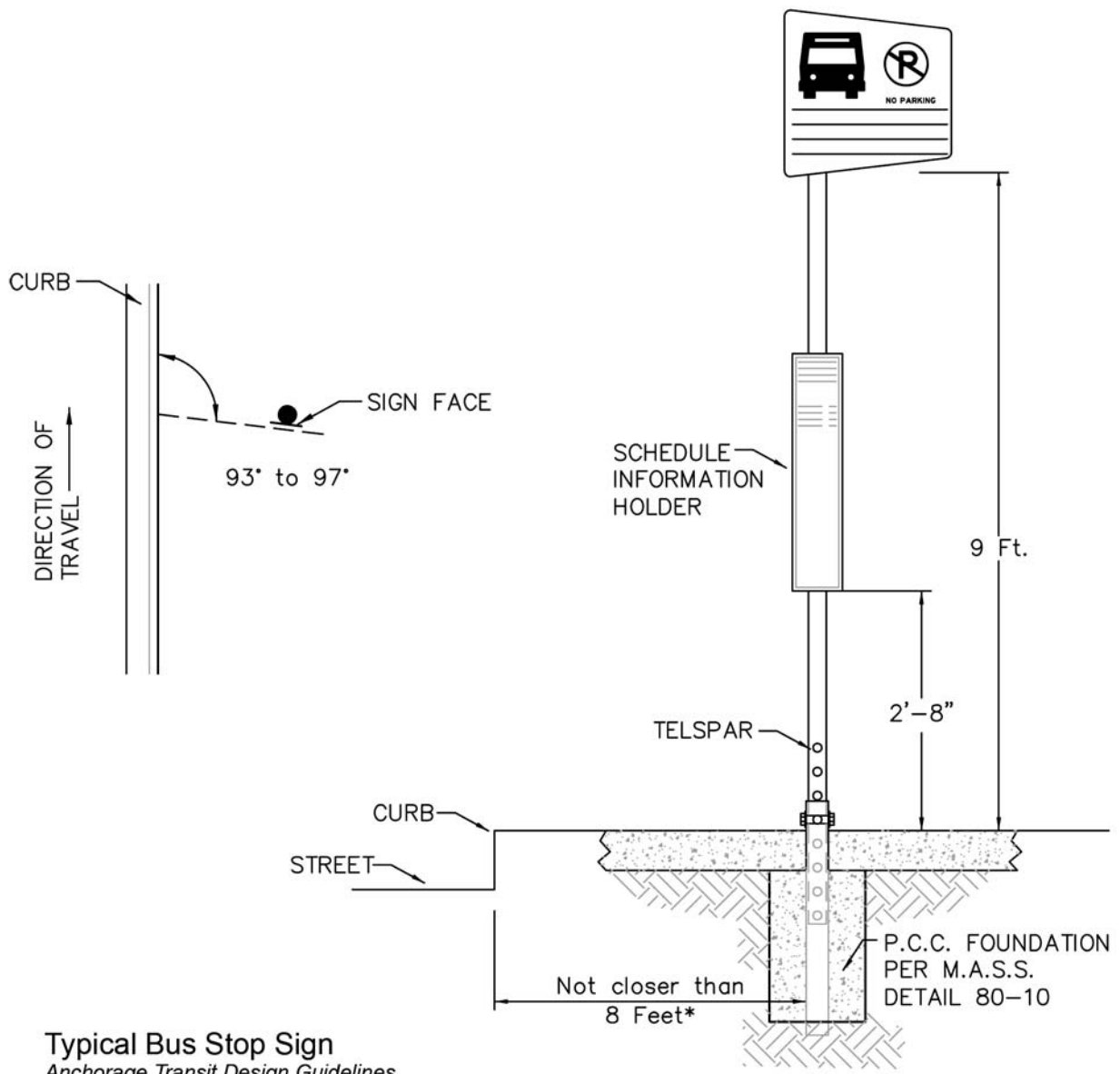

Typical Bus Stop Sign
Anchorage Transit Design Guidelines

*No closer than 19" in the Central Business District.
Preferred location is back of sidewalk/path

FIGURE 7-15 TYPICAL BUS STOP SIGN

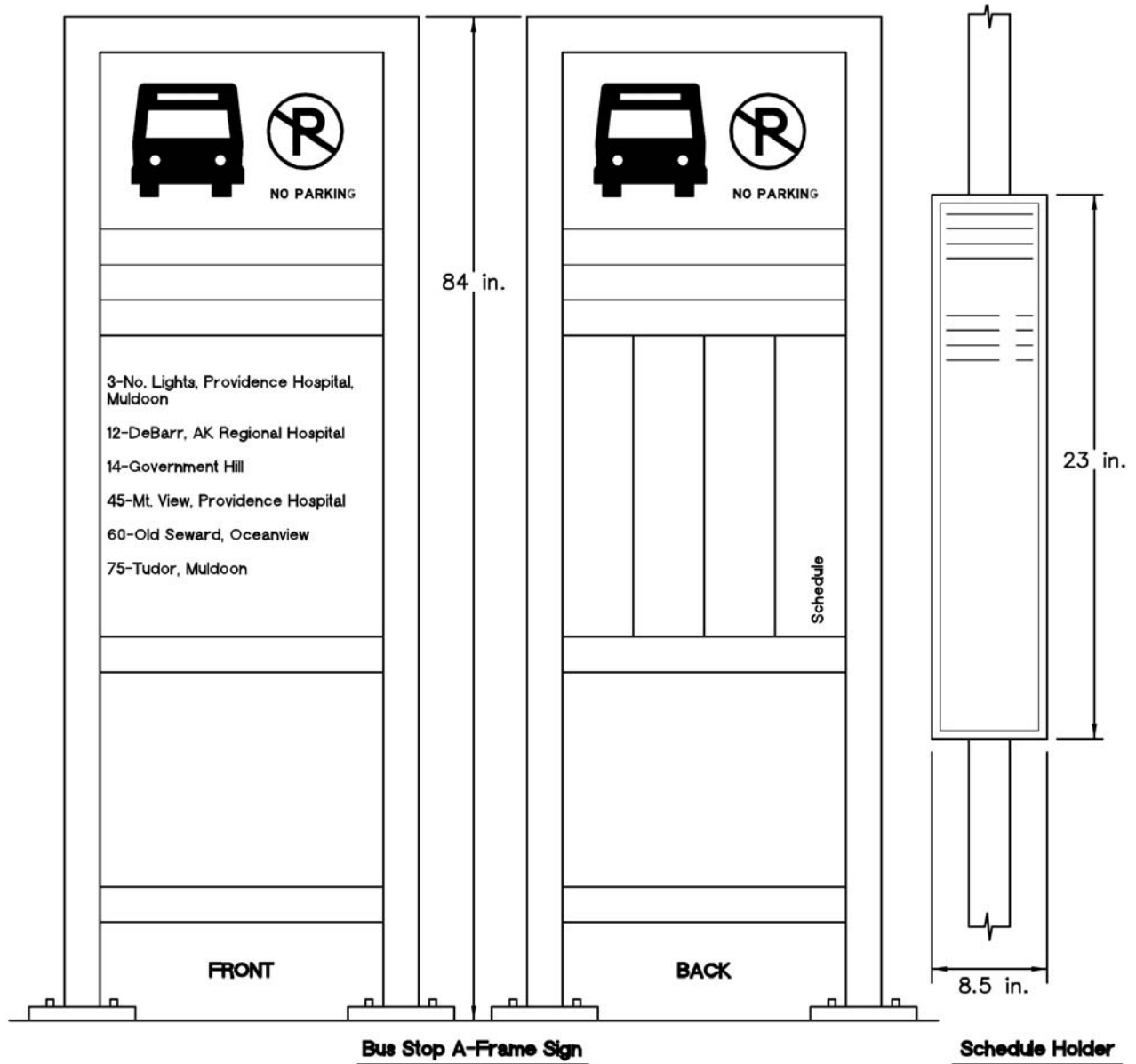

Bus Stop A-Frame Sign and Schedule Holder

Anchorage Transit Design Guidelines

FIGURE 7-16 BUS STOP A-FRAME SIGN AND SCHEDULE HOLDER

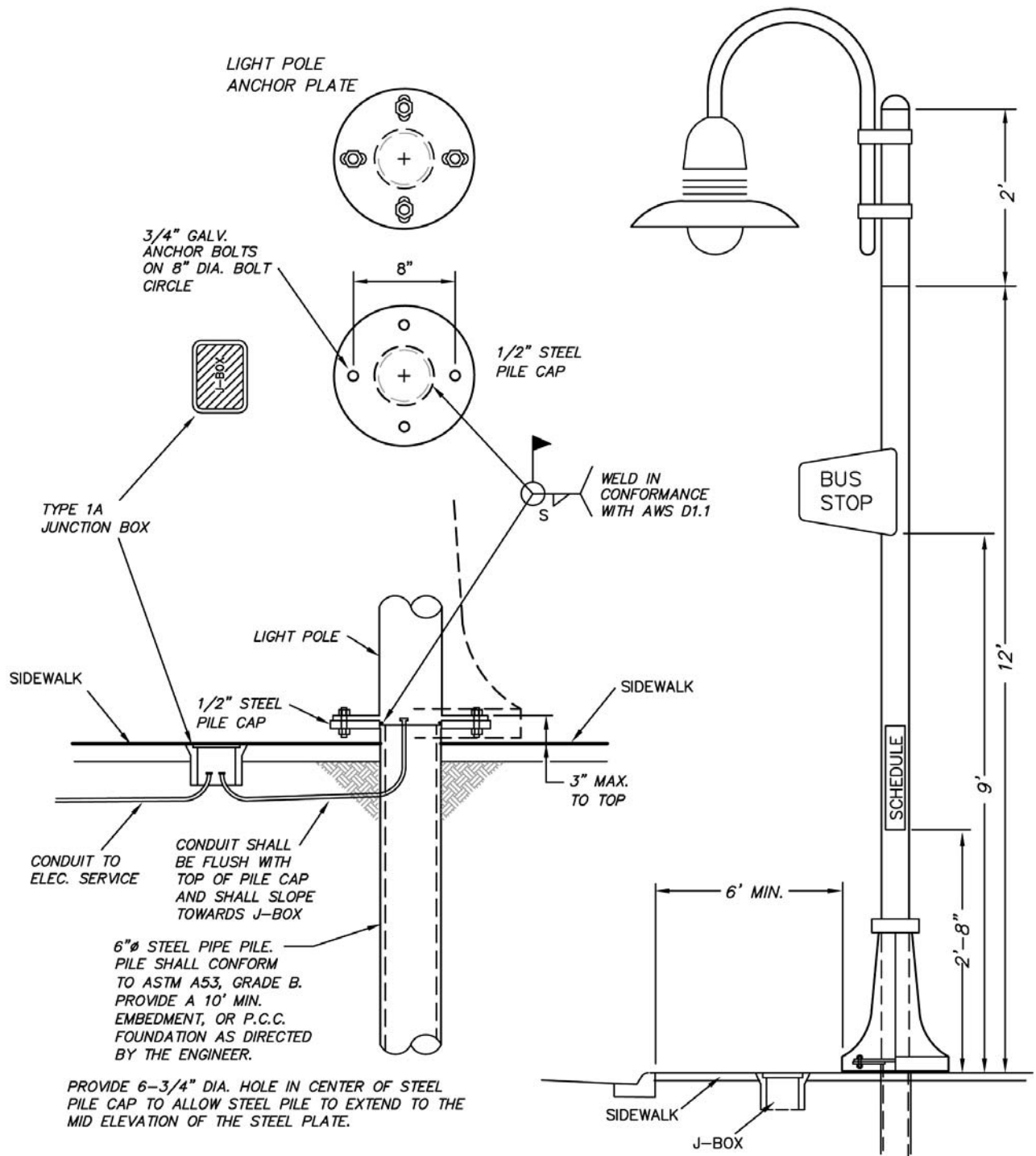

Bus Stop Light
Anchorage Transit Design Guidelines

FIGURE 7-17 BUS STOP LIGHT

b) Location

Schedule information holders are placed at all authorized bus stops.

A-frame signs are placed in areas of high foot traffic, high visibility, and/or where multiple routes intersect. A-frame signs should be placed such that at least 40 inches of clearance is provided for the passage of disabled persons.

7. Illumination

Passenger safety is enhanced by adequate lighting of the stop; riders feel more comfortable waiting for a bus at a lighted stop. Direct illumination of waiting passengers by a streetlight located near the start of the bus stop allows the bus driver to easily see waiting passengers.

Installing a supplemental light at the sign location provides light to read schedules and the bus stop sign can be mounted on the light pole (see Figure 7-17).

Illumination for bus stops shall be in accordance with the Design Criteria Manual Section 5.040 B and with ADA (ADAAG 4.30.8) illumination requirements. A further recommendation is that the illumination level on the surface of the sign not be significantly exceeded by a visible bright lighting source behind or in front of the sign. When street lighting does not provide the minimum illumination levels established in the Design Criteria Manual, new or supplemental lighting should be considered.

The PTD has identified a pedestrian scale light for bus stops. The light is manufactured by Lumec, Identification No. CANC3_47150A; telephone (514) 430-7040, Fax (514) 430-1453. (see Figure 7-17).

END OF SECTION 7.4

SECTION 7.5 OTHER TRANSIT FACILITIES

7.5 A Bus Layover Areas

A bus layover area is a bus parking area provided at a terminus of each bus route. The area is out of the traffic flow, and is used to give the driver a rest break, an opportunity to prepare for the return trip, and recovery time to ensure on-schedule operation. Turnouts will work as layover areas if no other option is available. Better though are designated corners of shopping mall parking lots (malls often serve as route ends), or other lots or areas where the driver can safely leave the bus.

1. Design

The appropriate length of a layover area is determined by the number of routes sharing the zone, the scheduled overlap of layovers (if any), and any sight clearance problems for nearby driveways or intersections.

For additional information concerning design criteria, see Section 7.4 B.2., Off-Street Bus Turnouts and Section 7.5 B., Park and Ride Facilities.

2. Location

Bus layover areas should be located as close as possible to existing bus stops serving major passenger generators (hospitals, malls, schools, recreation facilities, etc.).

Bus layover areas should be close to restroom facilities so drivers can refresh themselves before beginning another trip. A site with a restaurant nearby is desirable, although not necessary.

7.5 B Park-and-Ride Facilities

A Park-and-Ride Facility is an area providing parking for commuters in rural and lower density areas of the Municipality. The People Mover system currently has Park-and-Ride lots located at Business Boulevard and Joy Lutheran

Church in Eagle River, at the North and South Birchwood Loop interchanges, and at Thunderbird Falls. These facilities are designed to provide an incentive for time-sensitive commuters to use mass transit.

Park-and-Ride facilities can be a stand-alone development or can be created in partnership with strategically located commercial, church or other uses.

1. Design

Design criteria for park and ride facilities follow the same design standards as any other parking lot, and should be coordinated with either MOA PM&E or the DOT&PF, depending on the location and ownership of the sites. Lots should have a minimum of 10 spaces available for park and ride use and should provide for internal circulation.

Bus loading areas and auto drop-off (kiss-and-ride) areas should be designed to be near facility entrances to permit easy and fast transit bus access and egress.

The design criteria for Bus Turnouts and Bus Layover Areas shall be applied to the bus loading area. Shelters or benches and other passenger amenities should also be provided at park and ride lots.

Typical location and arrangement of sidewalks, waiting areas, parking areas and shelters are illustrated in Figure 7-18. Access standards must conform to Section 7.3 C.

2. Location

Lots should be located along corridors that experience significant actual or perceived traffic congestion. It is desirable for the lots to be visible from the corridor, and located so that potential users do not have to alter their travel patterns to use the lot. Good access and egress are essential.

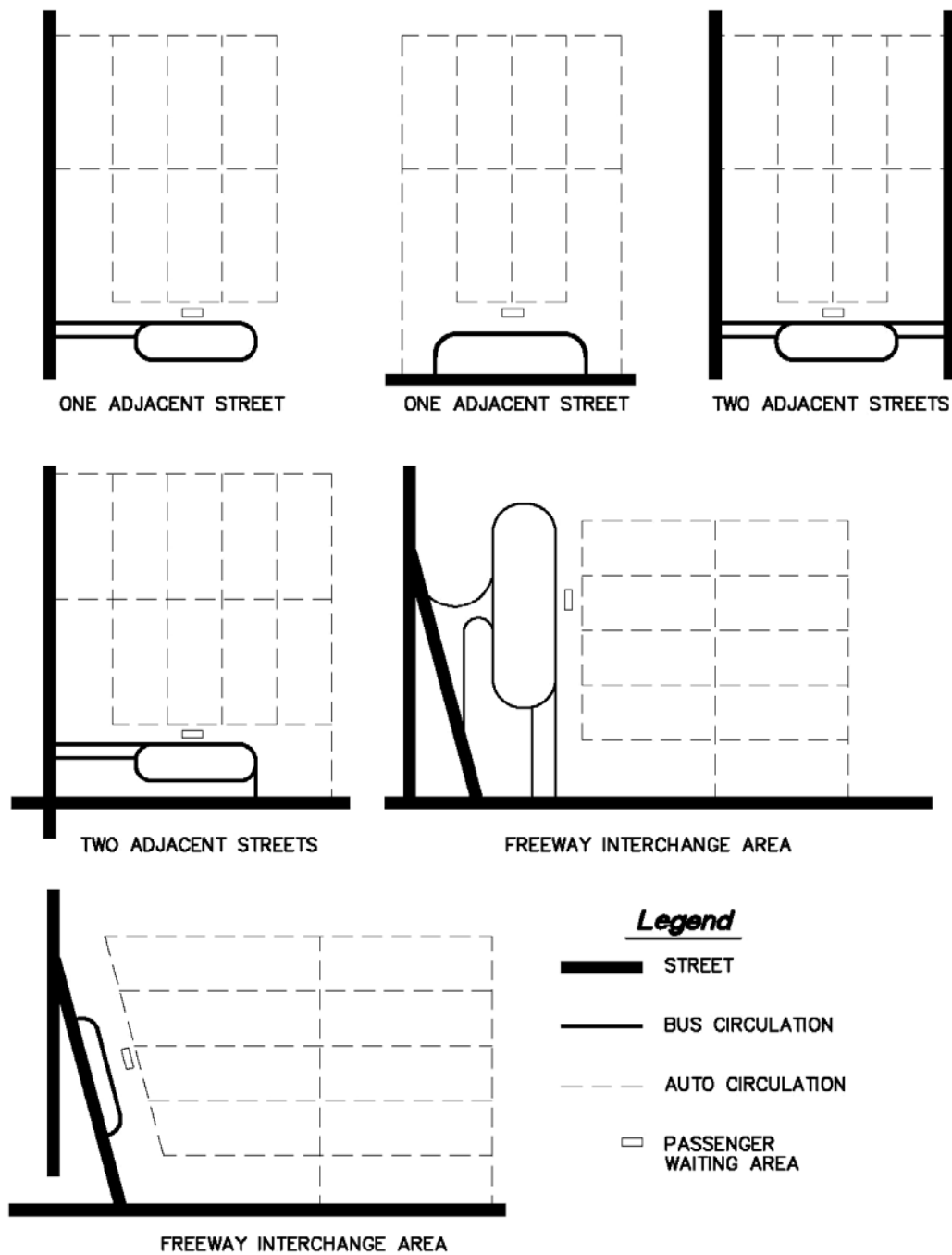

FIGURE 7-18 TYPICAL PARK-AND-RIDE APPLICATIONS WITH VARYING SITE CONDITIONS

Lots must be located on or close (within one block) to at least one bus line, and preferably more than one bus line. Lots should be at least four miles from the Anchorage Central Business District.

END OF SECTION 7.5

APPENDIX 7A

GLOSSARY

Accessible Route - A continuous, unobstructed path connecting all accessible elements and spaces of a building or facility. Interior accessible routes may include corridors, floors, ramps, elevators, lifts, and clear floor space at fixtures. Exterior accessible routes may include parking access aisles, curb ramps, crosswalks at vehicular ways, walks, ramps, and lifts (from ADAAG).

ADA - American with Disabilities Act.

ADAAG - American with Disabilities Act Accessibility Guidelines.

Alightings - The number of passengers who get off at a particular bus stop. Measured by the PTD through ongoing surveys.

Arterial - A major street or highway, the primary function of which is to serve through traffic. Arterials are ideally a continuous route providing limited access to adjacent property.

Articulated Bus - A high capacity (60 to 70 seated passengers) transit vehicle consisting of two sections hinged together.

Average Daily Traffic (ADT) - Identifies average traffic volumes as measured and reported by the Alaska Department of Transportation and Public Facilities (DOT&PF) or the Municipal Traffic Engineering Section. Most often averaged for the calendar year as Annual ADT, or AADT. The DOT&PF publishes an Annual Traffic Volume Report for the state, as well as traffic volume maps for roaded areas.

Average Operating Speed - Identifies prevailing traffic speeds as measured and reported by the DOT&PF or the Municipal Traffic Engineering Section. Normally published by the DOT&PF in the Anchorage Area Traffic Report.

BCR Route - Beginning of curb return. Where the tangent of the curve meets with the curb. It is at this point that measurements are taken to

determine the distance between the intersection and a following bus stop location and/or turnout.

Boardings - Represents the average number of passenger boardings at a particular stop as measured by the PTD through ongoing surveys.

Bus Berth - A designated bus parking area that holds one or more transit vehicles.

Bus Stop - A designated, permitted and signed area along a street or road in which buses stop to pick up and drop off passengers.

Bus Stop Number - A unique number assigned to each stop by the PTD. It allows for direct referencing of statistical and inventory information to a specific bus stop.

Bus Stop Spacing Area or Zone - Identifies the geographical area in which a bus stop is located: Major Commercial District, Urban or Suburban.

Bus Turnaround - A design that allows buses to return to the street they are serving in the opposite direction of travel.

Bus Turnout - A recessed bus stop area that is removed from the through traffic lanes of a road. Often constructed with curb and gutter. Always constructed with pedestrian connections.

Bus Turning Radii - The dimensions needed to accommodate bus turning movements in order to minimize bus encroachment into other lanes of traffic.

City Transit Bus - Identifies the 40 foot design vehicle, also referred to as CITY BUS, Transit Bus or Bus.

Collector - A road that collects traffic from local or residential streets and carries it to a destination or an arterial road. Normally, the design and operation of a collector intend to balance access to adjacent property with the movement of through traffic.

Cross Slope - The slope that is perpendicular to the direction of travel (see running slope).

Curb Cut - A driveway or pedestrian route through a depressed section of curb and gutter. Also, an approach with a radiused entry.

Curb Ramp - A short ramp cutting through a curb or built up to it.

DART (Dial A Ride Transit) – People Mover’s Deviated Fixed Route service.

Demand Responsive Route - A form of paratransit service characterized by flexible routing and scheduling of small vehicles to provide door-to-door or point-to-point transportation at the user's demand by prior arrangement, either by telephone for "dial-a-ride" service or other prescheduling arrangements.

Deviated Fixed Route Service - This type of transit is a hybrid of fixed-route and demand-response services. While a bus or van passes along fixed stops and keeps to a timetable, the bus or van can deviate its course between two stops to go to a specific location for a pre-scheduled request. Often used to provide accessibility to persons with disabilities

Dwell Time - The time, in seconds, that a transit vehicle is stopped while picking up or dropping off passengers.

ECR - Ending of curb return. Where the tangent of the curve meets with the curb. It is at this point that measurements are taken to determine the distance between the intersection and a preceding bus stop location and/or turnout.

Express Bus Service - Bus service that operates nonstop from a park-and-ride lot or other designated point of origin to a major destination.

Far Side Bus Stop - A bus stop located at the far side of or the "downstream" side of an intersection with respect to a specific stream of traffic.

Fixed Route Bus Service - Bus service provided on a repetitive, scheduled basis along

defined routes. Buses stop at designated locations or on demand.

Functional Classification - Identifies the class of the roadway as established by the Municipality of Anchorage's Official Streets and Highways Plan.

Intermediate Stop Spacing - These guidelines call for closer spacing between bus stops as adjacent development density increases. Three zones of density are considered: Major Commercial District, Urban and Rural.

Intersection Radii - Corner curb dimensions. The radius of the curb arc at each corner of the intersection.

Local Street - A road that provides direct access to residential lots.

Mid Block Bus Stop - A transit stop located between intersections.

Near Side Bus Stop - A transit stop located immediately before or on the "upstream" side of an intersection with respect to a specific stream of traffic.

Park and Ride Lot - An area designated for the parking of passenger vehicles so that users can continue their trip in a multi-occupant vehicle, such as a carpool, vanpool or bus.

Peak Hour Curb Lane Volume - The amount of curb lane traffic passing by a bus stop in the peak hour. Determined by the formula:
[(Peak Hour % x AADT) x % Directional Split] / number of lanes in direction considered

Pedestrian Accessway - A lighted, paved and handicapped accessible walkway that provides convenient access to transit facilities and bus stops from adjacent residential, office or retail developments.

Pulse Scheduling - A form of scheduling that insures that all routes with coordinated schedules converge at a common point with a brief layover, to allow for transfers between any of the routes.

Ramp - A walking surface that has a running slope greater than 1:20 (from ADAAG).

Residential Street - A road that provides direct access to residential lots.

Right-of-Way – (ROW). The strip of land owned by or under the direct control of a transportation system, occupied by or intended for a transportation facility.

Running Slope - The slope that is parallel to the direction of travel (see cross slope).

Sidewalk Route - A walk in the public right-of-way along a vehicular way that is part of a pedestrian circulation network. (from proposed ADAAG, Section 14. Same as a walk, but does not include plazas or courts.)

Signal Priority - Traffic signal changes that give priority to high-occupancy vehicles (HOVs), such as signal preemption, separate HOV phases, and signal offset adjustments.

Site - A parcel of land bounded by a property line or a designated portion of a public right-of-way. (from ADAAG)

Site Infeasibility - Existing physical or site constraints which prohibit the incorporation of elements, spaces or features which are in full and strict compliance with the minimum requirements for new construction in the public right-of-way and which are necessary to provide accessibility.

Transit Route - A designated path followed by one or more buses with specific beginning and ending points.

Transfer Point - A bus stop used by passengers to transfer from one route to another. Normally requires that the stop be placed off-street in a turnout.

Transit Bus Stop No. - A number assigned by the PTD. It allows for direct referencing of statistical and inventory information to a specific bus stop.

Transit Center - A bus facility that serves as a hub where several transit routes meet, normally placed near commercial activity. Passengers may change vehicles or modes of transportation in a pleasant, out-of-the-weather environment.

Transit Corridor - A broad geographic band (usually one-half mile) that follows a general directional flow connecting major origins and destinations of trips and that contains a number of streets, highways, and transit route alignments. Land use development within the corridor is provided with certain incentives to encourage transit supportive densities and site layouts.

Travel Lane - A lane devoted exclusively to vehicular traffic.

Walk Route - An exterior pathway with a prepared surface intended for pedestrian use, including general pedestrian areas such as plazas and courts (from ADAAG).

Warrant - A criterion that must be satisfied in order for a specific improvement to be built. Used in connection with the installation of bus stops in turnouts and traffic signals.

END OF APPENDIX 7A

APPENDIX 7B

SELECTED REFERENCES

Regional Standards

MOA-PM&E, *Municipality of Anchorage Standard Specifications (MASS)*, 1994, Anchorage, AK

MOA-PM&E and PTD, *Municipality of Anchorage Design Criteria Manual (DCM)* (MASS), 2005, Anchorage, AK

National Standards

ADAAG, *The United States Access Board Americans with Disabilities Act and Architectural Barriers Act Accessibility Guidelines*.

AASHTO, *Guide for the Design of High Occupancy and Public Transfer Facilities*, 1983, Washington, D.C.

AASHTO, *A Policy on Geometric Design of Highways and Streets*, 2004, Washington, D.C.

Access Board, *Accessible Rights-of-Way: A Design Guide*, 1999, Washington, D.C.

American National Standards Institute (ANSI) A117.1 - 1986 (Accessibility Standards for non-federal buildings)

Balog, Chia, et. al., *Accessibility Handbook for Transit Facilities*, U.S. Department of Transportation, Federal Transit Administration, 1992, Washington, D.C.

U.S. Equal Employment Opportunity Commission and the Department of Justice, *Americans with Disabilities Act Handbook*, 1991, Washington, D.C.

Transit Facility Design Standards

Metropolitan Transit Development Board, *Designing for Transit*, 1993, San Diego, CA

Municipality of Metropolitan Seattle, *Metro Transportation Facility Design Guidelines*, 1991, Seattle, WA

North San Diego County Transit District, *Design Outlines for Bus Facilities*, San Diego, CA

Orange County Transportation Authority, *Design Guidelines for Bus Facilities*, 1992, Santa Ana, CA

Regional Transit, *Design Guidelines for Bus and Light Rail Facilities*, 1987, Sacramento, CA

Regional Transportation District, *Transit Facility Design Guidelines*, 1987, Denver, CO

Short-Elliott-Hendrickson, Inc., *Guidelines for the Design of Transit Related Roadway Improvements*, Metropolitan Transit Commission, 1983, St. Paul, MN

Tri-Met Planning and Scheduling Department with David Evans and Associates, *Tri-Met Bus Stops and Passenger Amenities Standards Manual*, 1993, Portland, OR

Other References

City of Phoenix, *Street Classification System: General Policy Document*, 1992, Phoenix, AZ

King, Larry, "Americans with Disabilities Act and the Design of Highway-Related Facilities," in *ITE Journal*, January 1993, Washington, D.C.

Land Design North and HDR Engineering, *Anchorage Trails Plan Update, Public Review Draft*, 1993, Anchorage, AK

Oregon Department of Transportation,
*Oregon Bicycle and Pedestrian Plan, An
Element of the Oregon Transportation Plan*,
June 14, 1995, Salem, OR

Federal Highway Administration
(FHWA), *ROUNDABOUTS: An Informational
Guide* (FHWA-RD-00-067), 2000, Washington,
D.C.

END OF APPENDIX 7B