

THE COMPLETE COURSE IN INTERIOR DESIGN



**DESIGN
ELEMENTS GUIDE**



New York
Institute of
ART+DESIGN



Acknowledgements: New York Institute of Art and Design (NYIAD) Course materials are written by NYIP staff, project managers, subject matter experts, and faculty. *The Complete Course In Interior Design—Design Elements Guide* was written by NYIAD faculty and staff along with NYIAD Director of Education Jay Johnson and NYIAD Curriculum Developer Steven Evans. The Lessons were designed by Ondine Bue and NYIAD Curriculum Designer Keith Gallagher.

New York Institute of Art and Design is a registered trademark of Distance Education Co. LLC in the United States and/or other countries.

© 2013 Distance Education Co. LLC. All Rights Reserved.

Visit Us Online at www.NYIAD.edu

ASID1LSN6.indd



TABLE OF CONTENTS

DOORS	4
WINDOWS	8
HEATING/COOLING UNITS	10
DRAWING STAIRS	11
MOLDINGS AND BASEBOARDS	13
FIREPLACES	15
COLUMNS	16
CLOSETS	17
ARCHITECTURAL SYMBOLS	18
HAND LETTERING CHART	19
UPHOLSTERED FURNITURE GUIDE	20

INTRODUCTION

This is a guide to different styles of interior architectural elements (and instructions on how to draw them) that you will find useful in your career as a professional interior designer. Keep this handy as a reference guide in case a certain design element or technique escapes your memory. Each concept will be discussed in detail later in the Course, so if you're looking at this for the first time, don't worry if you don't understand everything right away.

Some of the sections in this Guide specifically relate to lessons you'll receive later in the Course. Feel free to study them now if you wish—and then refer to them periodically as you go through the Course.

TYPES OF DOORS

Under each illustration you'll see how to indicate that type of door on a floor plan.

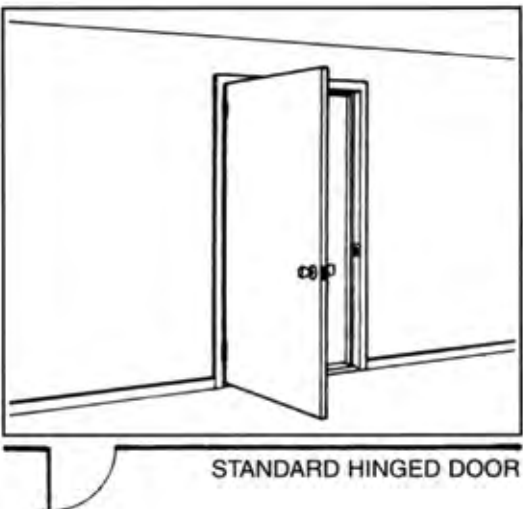
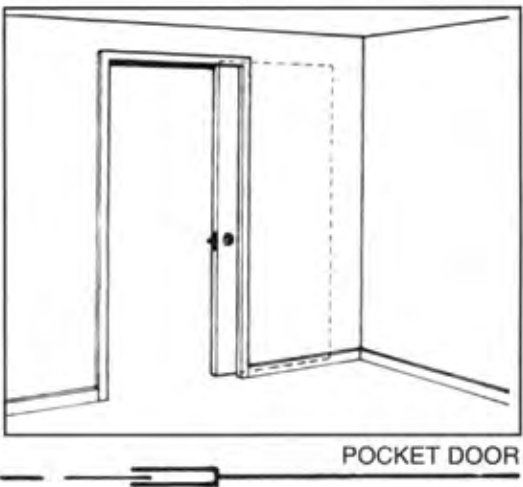



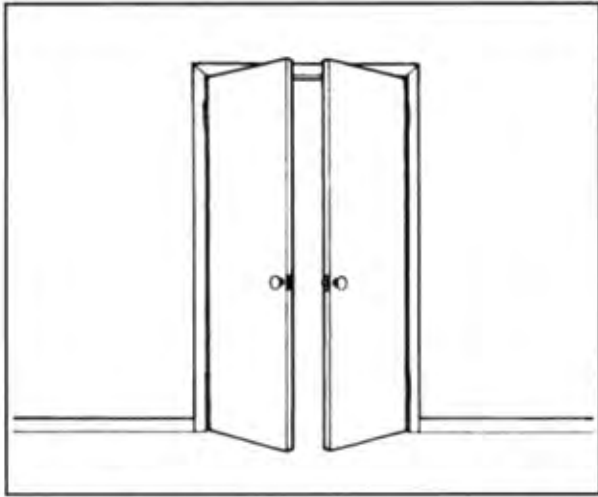

DOUBLE DOOR

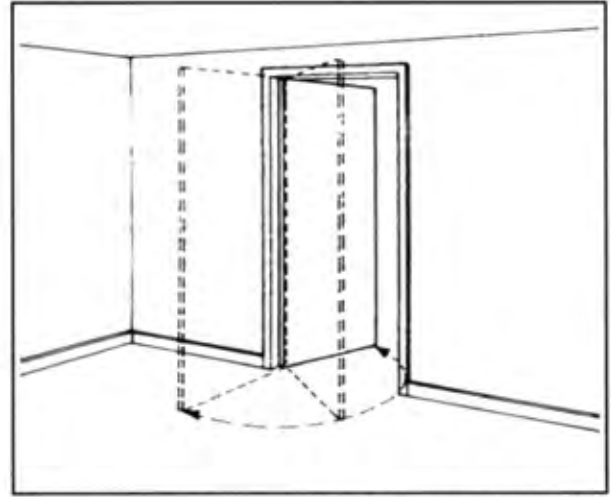

SWINGING DOOR

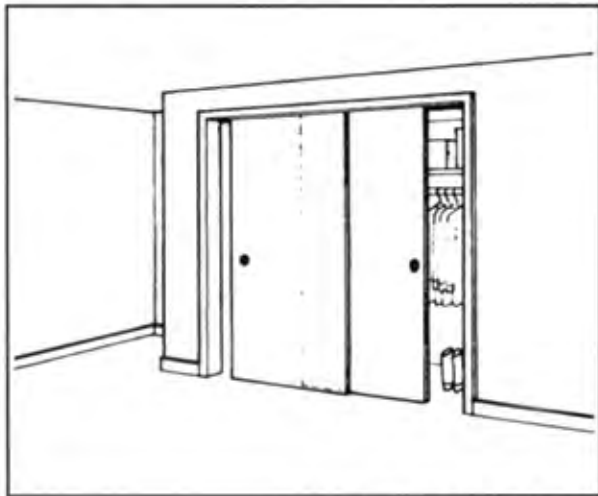
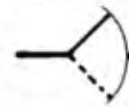

SLIDING CLOSET DOOR

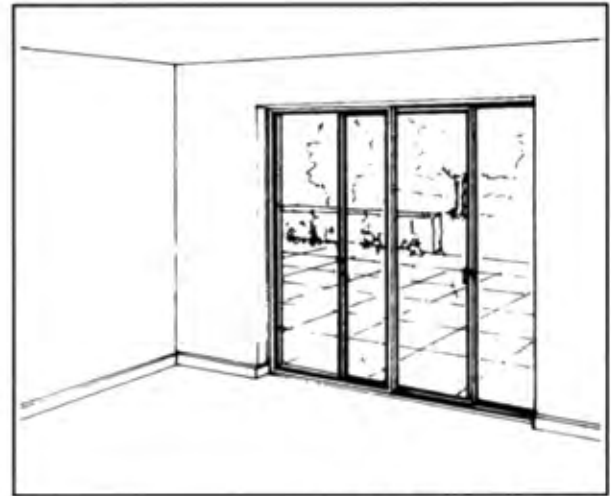

SLIDING GLASS DOOR

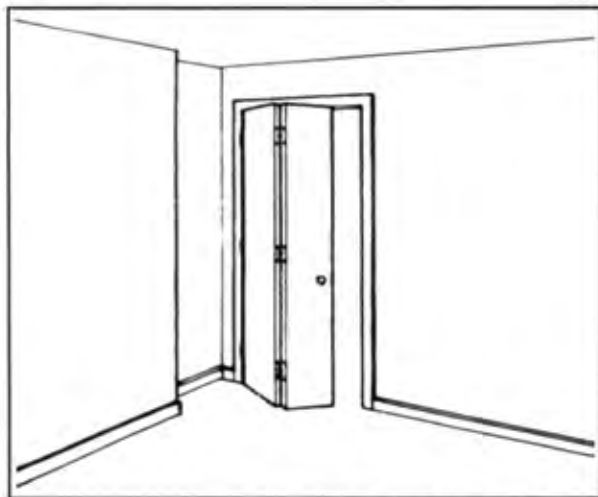

BIFOLD WITHOUT TRACK

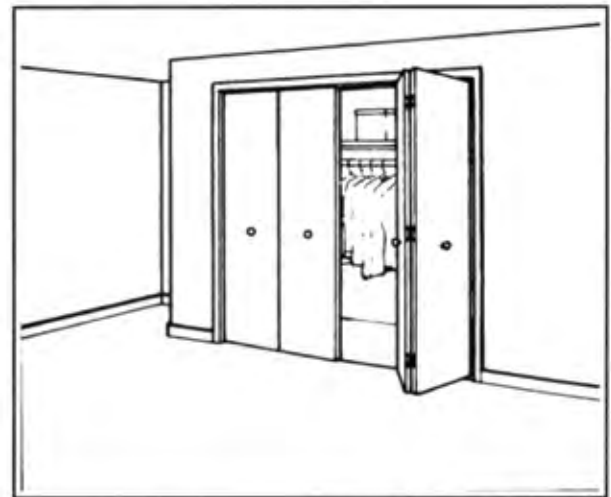

BIFOLD ON TRACK



STYLES OF DOORS

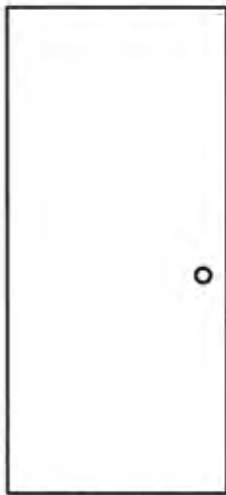

FLUSH

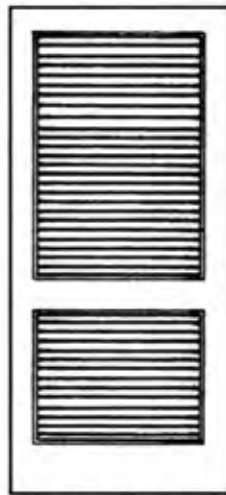

SHUTTER

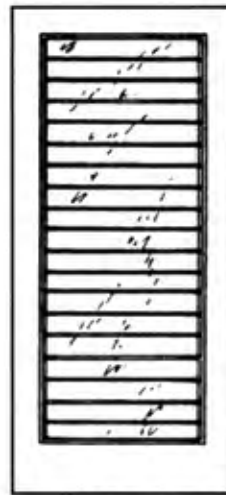

JALOUSIE

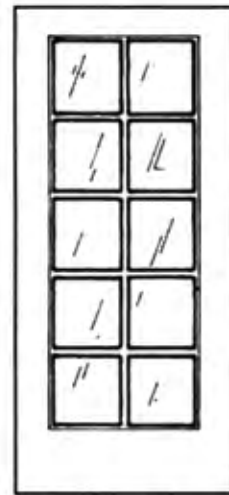

FRENCH

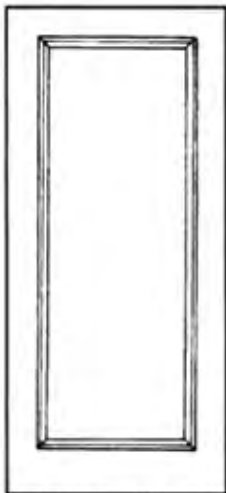

SINGLE PANEL

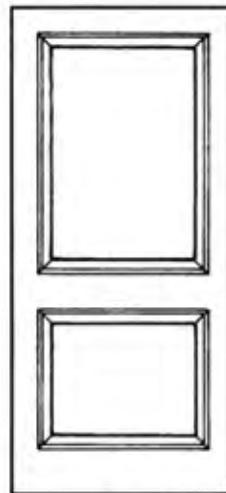

DOUBLE PANEL

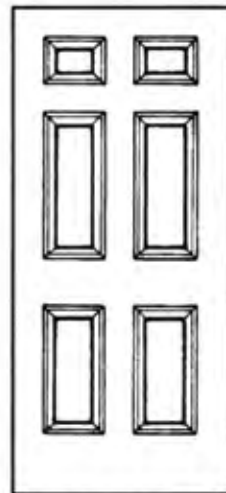

GEORGIAN



FARMHOUSE

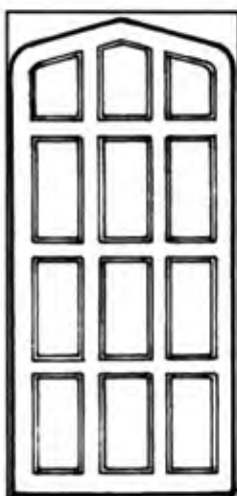

TUDOR

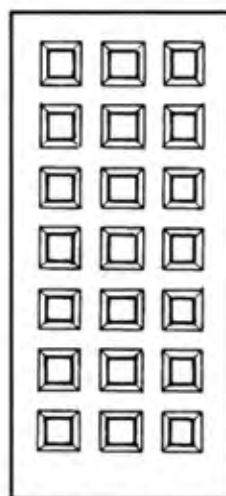

MEDITERRANEAN

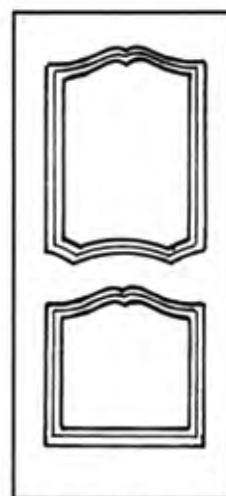

LOUIS XV

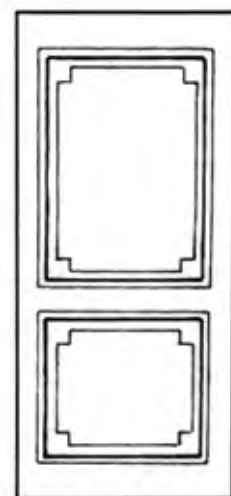

LOUIS XVI

TYPES OF WINDOWS



DOUBLE-HUNG

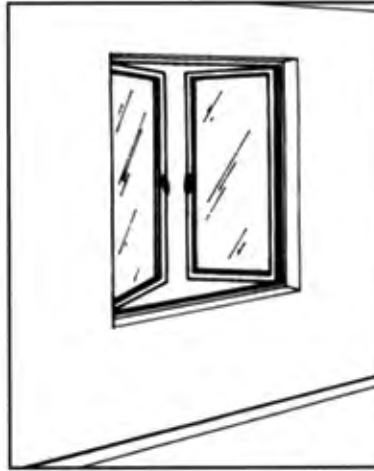

CASEMENT

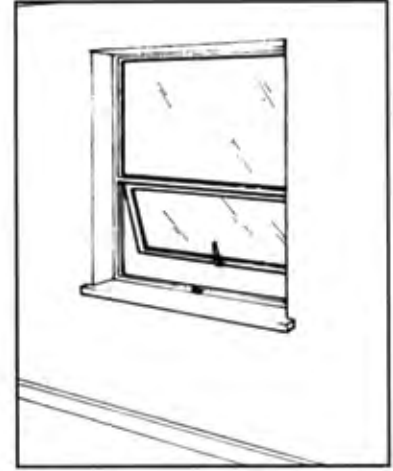

AWNING



JALOUSIE

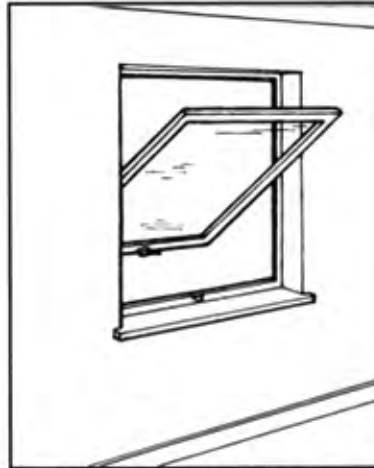

HORIZONTAL PIVOT

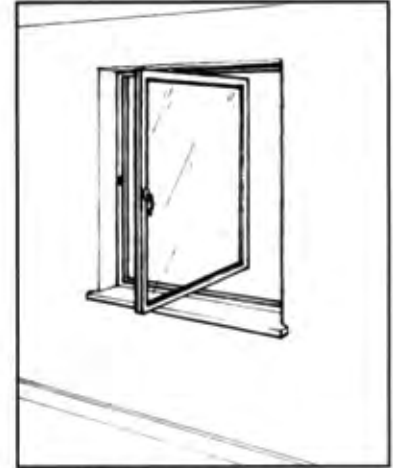

VERTICAL PIVOT

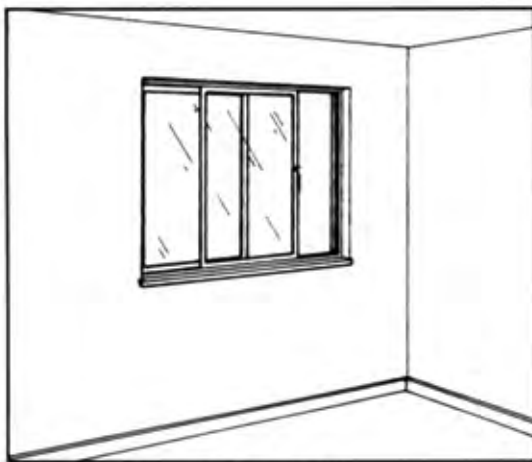

SLIDING

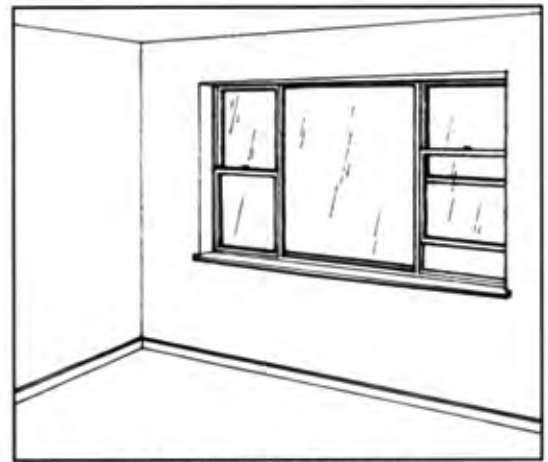

COMBINATION PICTURE
AND DOUBLE-HUNG



TYPES OF HEATING/COOLING UNITS

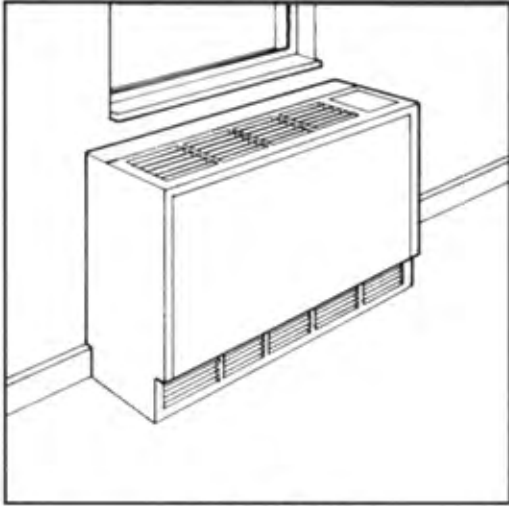

HVAC UNIT

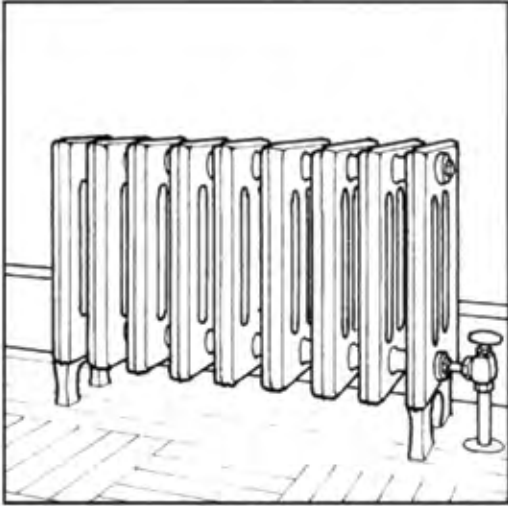

RADIATOR

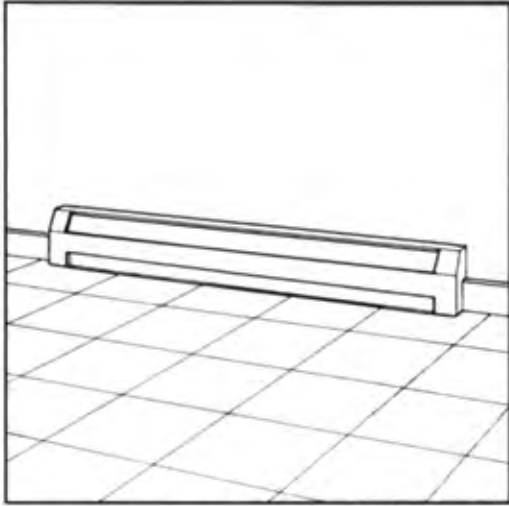

BASEBOARD HEATER



WINDOW AC UNIT



WALL AND CEILING REGISTER

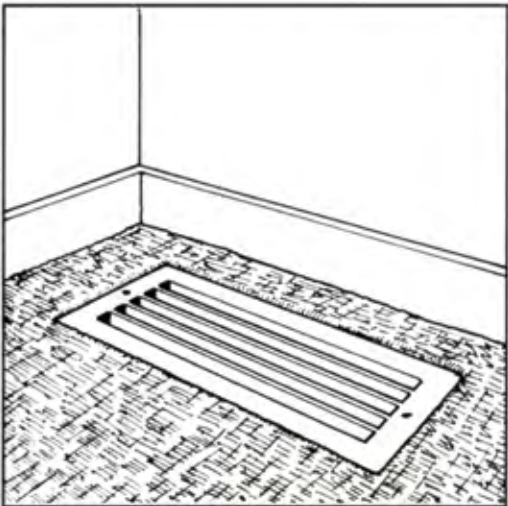

FLOOR REGISTER

DRAWING STAIRS

In *Figure 1* you see a staircase labeled with the names given to its different parts. In *Figure 1A* you see a detail of how to measure steps. *Rise* refers to the height of each step—usually 6" to 8". *Run* refers to the depth of each tread—usually 10" to 11".

In *Figure 2* you see a typical straight staircase. How do you draw it? Simply count the number of steps, and measure the "*rise*" and "*run*" of one step. Record this information in a rough sketch, as shown in *Figure 2A*. Then, in a finished floorplan draw this staircase to scale, as shown in *Figure 2B*. In your *Room Condition Checklist*, you may record other information, such as a brief description of the staircase, its handrail, balustrades, and any other significant details.

As you can see in *Figures 2A* and *2B*, only the lower part of the staircase is shown in plan—ending in a slash drawn diagonally across the stairs as shown in *Figure 2C*. This is the conventional way to indicate stairs that are leading up to a higher floor. It simply means that not all of the staircase is considered to be part of the floor you are on.

As you can also see, an arrow in *Figure 2A* is labeled "Up." Why do we label this arrow as "Up"? (After all, doesn't this staircase also come "Down" from the floor above?) We always label the arrow in the direction of stairs as viewed from inside this room we are drawing. If a staircase ascends from that room, we label it "Up." If a staircase descends from that room, we label it "Down."

For example, in *Figure 3* you see a staircase that descends from the room. In *3A* you see how to draw a rough sketch of this staircase. In this case, because this staircase descends from this room, we label it "Down."

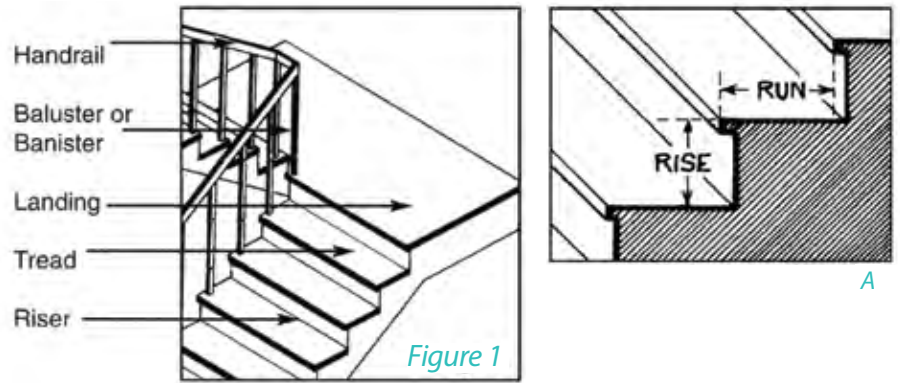

Figure 1

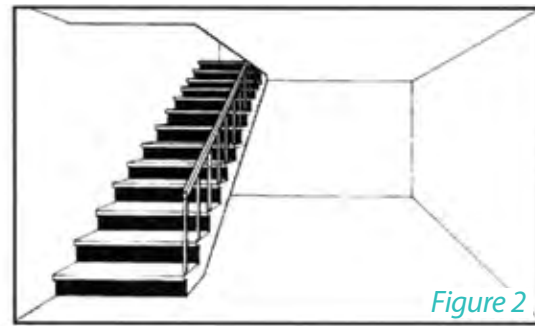
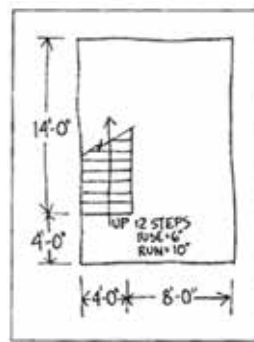
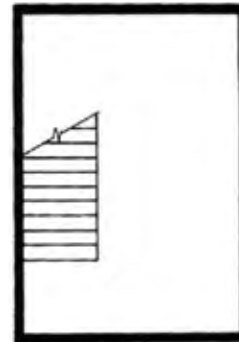

Figure 2



A



B

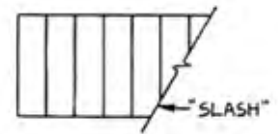

C

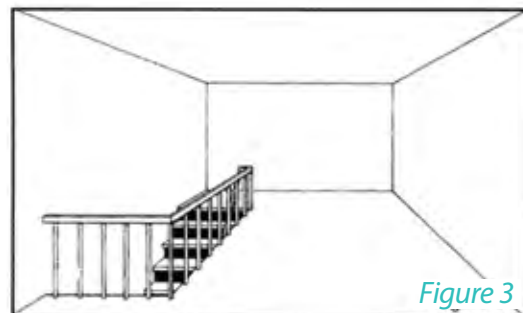
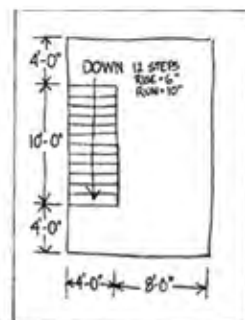
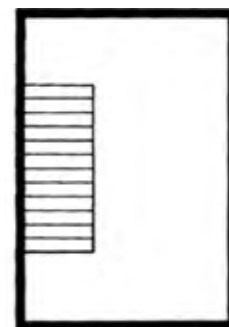

Figure 3



A



B

STAIRS: EXERCISE

Sometimes you'll have a situation such as that in [Figure 4](#), in which a pair of staircases is one over the other.

HOW DO YOU DRAW THEM?

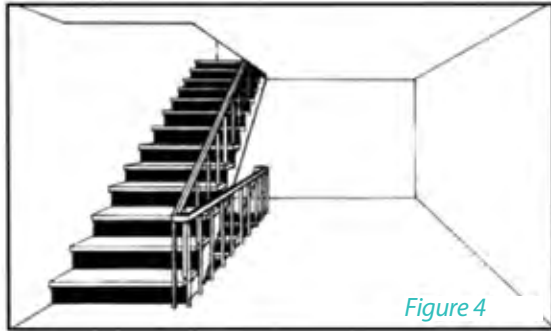
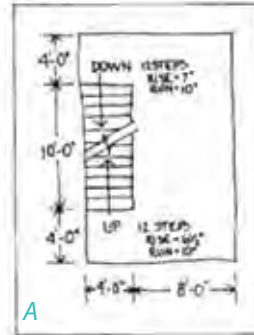
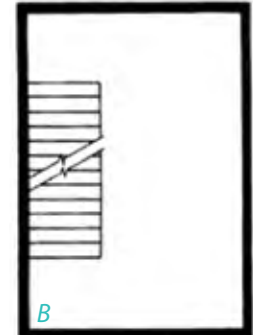

Figure 4

In [4A](#) you see a rough sketch. In [4B](#), a finished floorplan. While these may look confusing at first, you can see that these drawings clearly indicate that one staircase is over another by slashing each staircase in the middle.



A



B

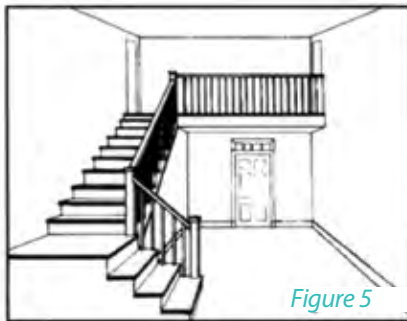
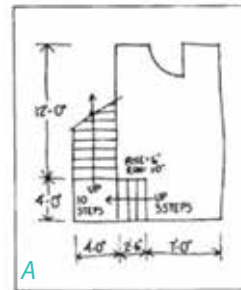

Figure 5

How should you draw the staircase shown in [Figure 5](#)?



A

Draw it as shown in [5A](#) and [5B](#).

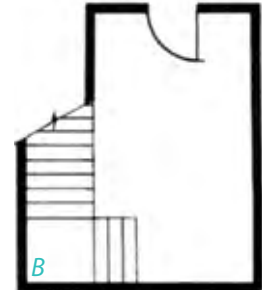

B

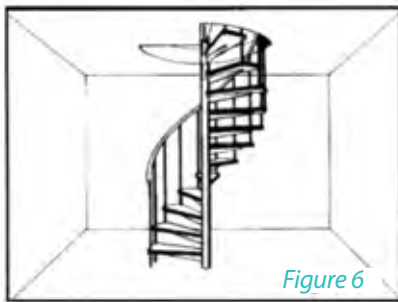
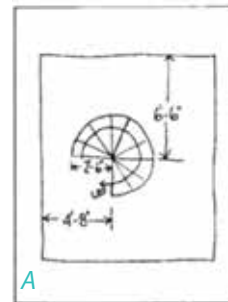

Figure 6

What about a spiral staircase, shown in [Figure 6](#)?



A

Draw it as shown in [6A](#) and [6B](#).

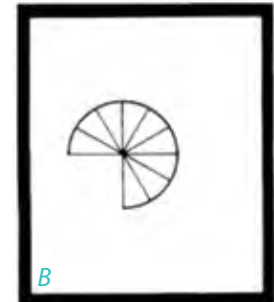

B

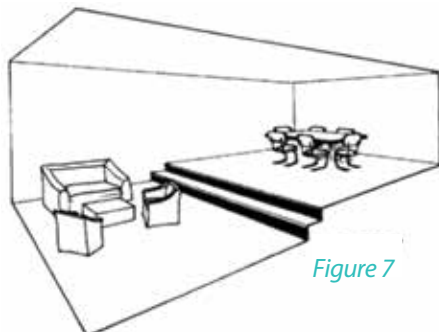
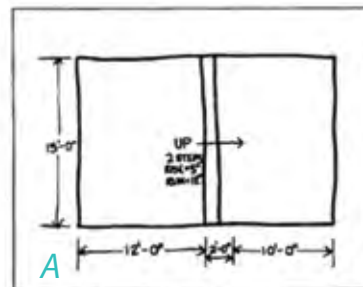

Figure 7

Finally, how should you indicate a raised area in a room, such as that shown in [Figure 7](#)?



A

Draw it as shown in [7A](#) and [7B](#).



B

STYLES OF MOULDINGS

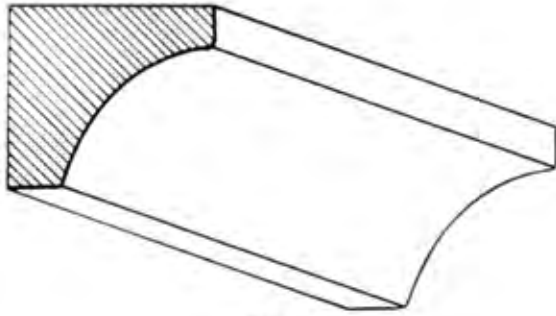

COVE

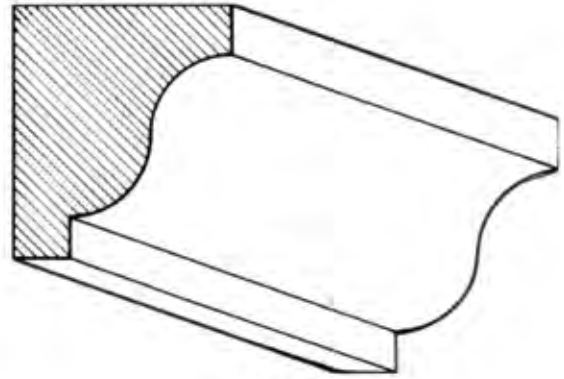

OGEE

BASEBOARDS

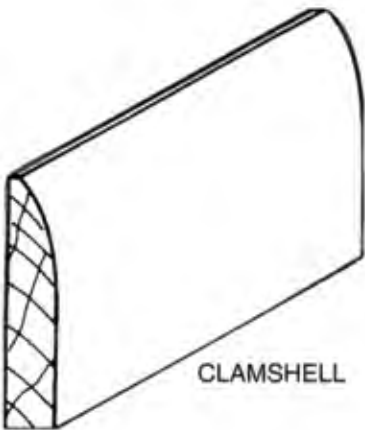

CLAMSHELL

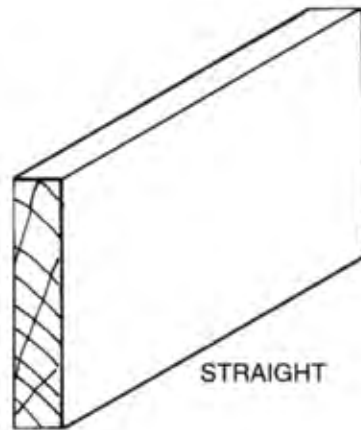

STRAIGHT

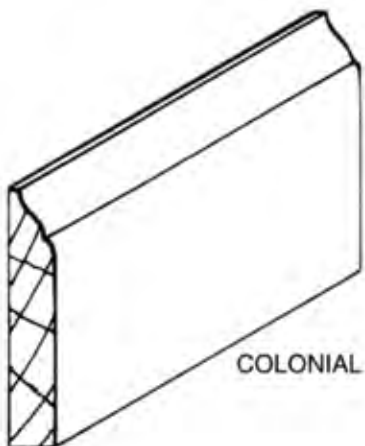

COLONIAL

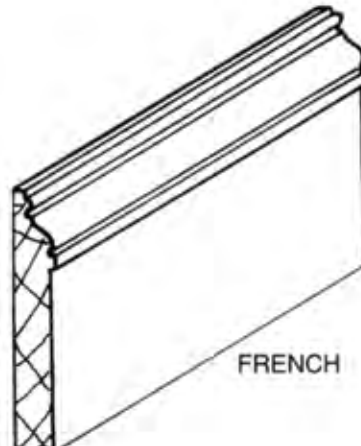

FRENCH



STYLES OF FIREPLACES

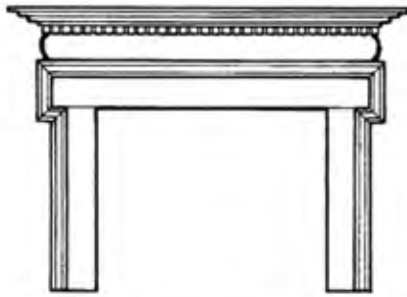

GEORGIAN

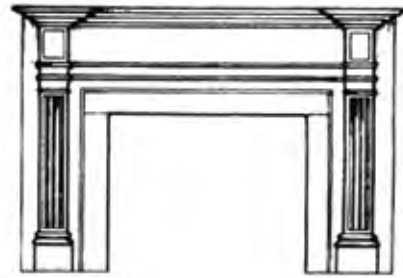

FEDERAL

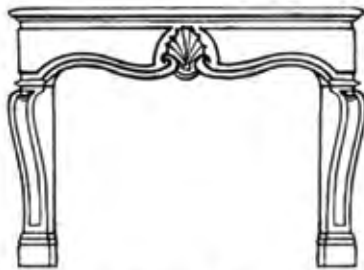

LOUIS XV

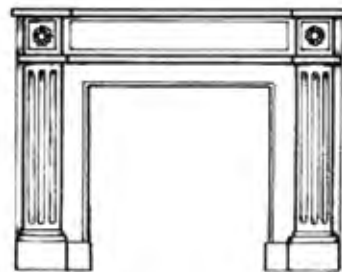

LOUIS XVI

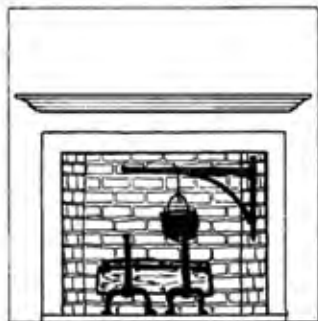

FARMHOUSE

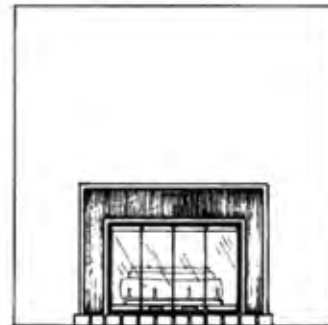

CONTEMPORARY

FREESTANDING



TRADITIONAL



CONTEMPORARY

HOW TO SKETCH COLUMNS

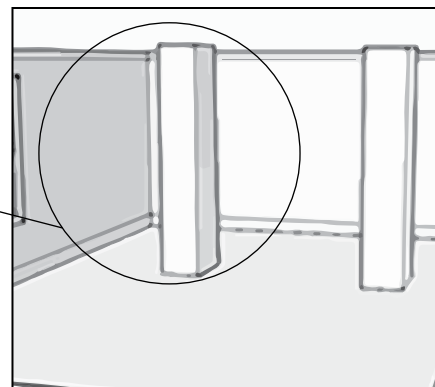
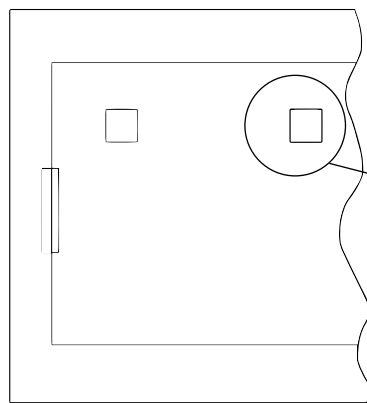
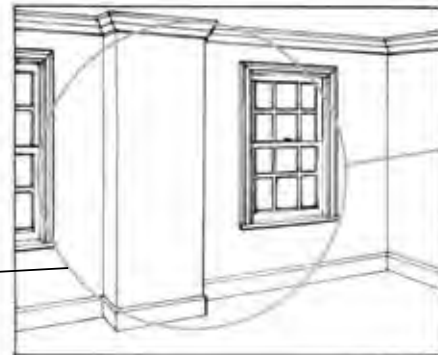
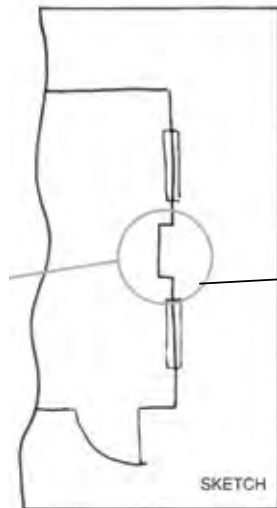
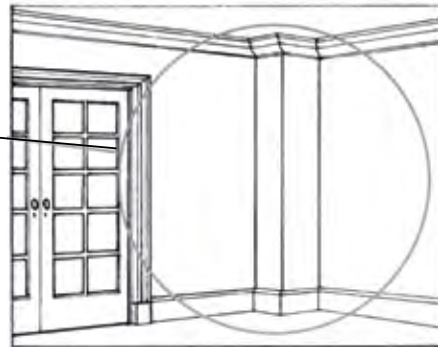
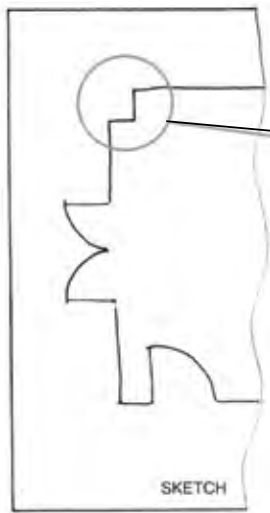

HOW TO SKETCH CLOSETS

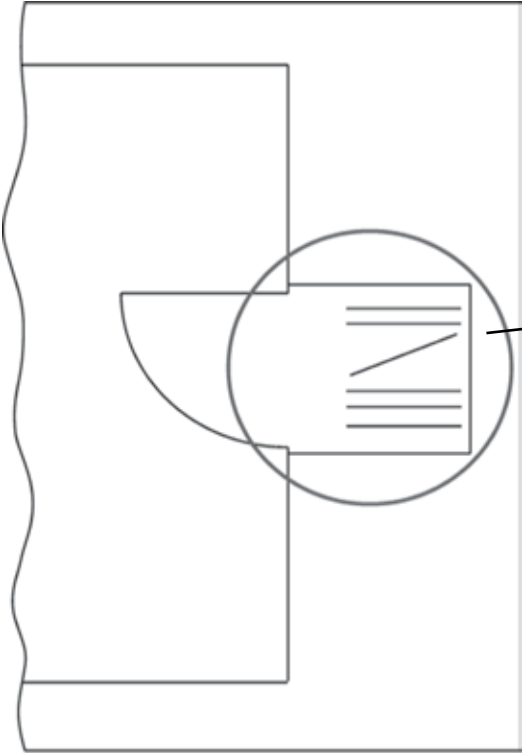

CLOSET WITH HINGED DOOR - SKETCH

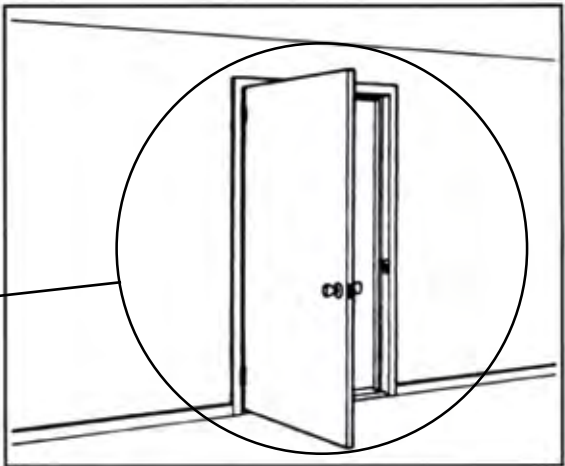

CLOSET WITH HINGED DOOR

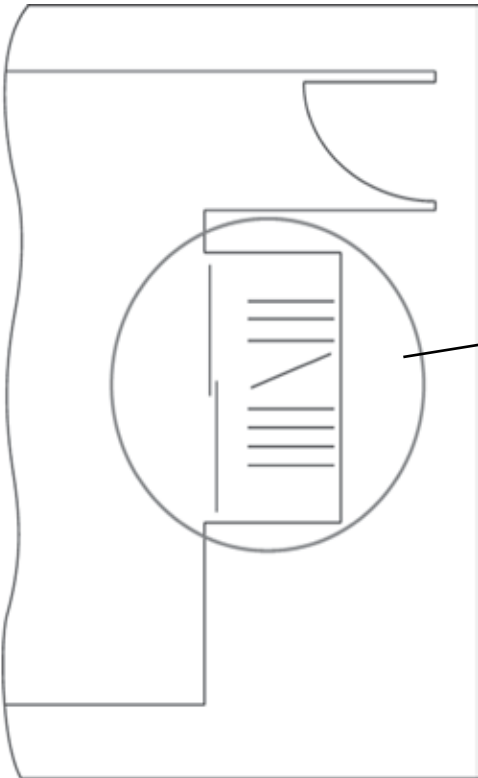

CLOSET WITH SLIDING DOORS - SKETCH

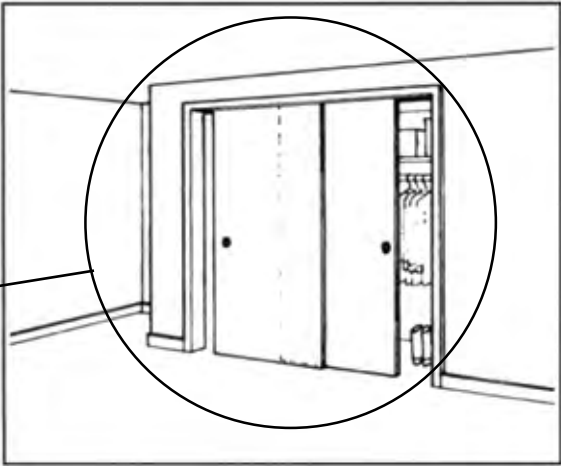

CLOSET WITH SLIDING DOORS

ARCHITECTURAL SYMBOLS

The following are some architectural symbols that you may need as you learn how to create sketches and floorplans.

ROUGH SKETCH

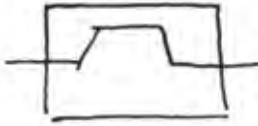

FLUSH FIREPLACE



BUILT-IN BOOKCASE



COUNTER WITH PASS-THRU



OPEN DOORWAY



FLOOR ELECTRICAL OUTLET



CEILING FAN

FINISHED PLAN



FLUSH FIREPLACE



BUILT-IN BOOKCASE



COUNTER WITH PASS-THRU



OPEN DOORWAY



FLOOR ELECTRICAL OUTLET

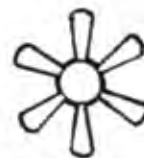

CEILING FAN

HAND LETTERING CHARTS

A B C D E F G H I J K L M N

O P Q R S T U V W X Y Z

a b c d e f g h i j k l m n

o p q r s t u v w x y z

UPHOLSTERED FURNITURE GUIDE

When you have furniture custom made, you will most often be dealing with upholstered sofas or chairs. The purpose of this Guide is to help you make the decisions necessary to have such furniture custom made.

At first, the variety of choices may seem bewildering. As you will see in this Guide, however, with a little knowledge, these choices are really easily made.

GENERALLY, YOU WILL CUSTOM-DESIGN A SOFA OR CHAIR IN TWO STEPS.

- First, you will decide upon the general style and proportions of the piece of furniture.
- Second, you will specify the details you want:
 - a. Base Details
 - b. Skirt Details
 - c. Arm Details
 - d. Cushion Details

Accordingly, this *Upholstered Furniture Guide* is divided into two parts.

First, you will find charts showing typical styles of sofas and chairs.

Armed with this information, you will have no problem custom designing your own sofas and chairs. All you have to do is combine the different styles, proportions, and details in any way you like.

Your custom upholsterer should be able to help and guide you here. The upholsterer will show you the styles and details the upholstery shop is prepared to manufacture, possibly suggesting some variations not shown here. With this help, and the information in this Guide, you should have no difficulty designing upholstered chairs, sofas, and other pieces of furniture to your exact specifications.

TYPICAL DIMENSIONS FOR UPHOLSTERED FURNITURE

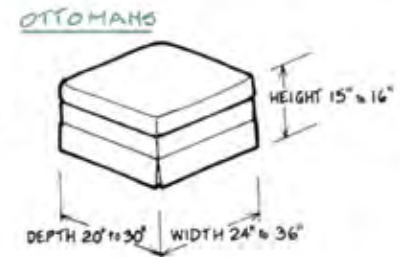
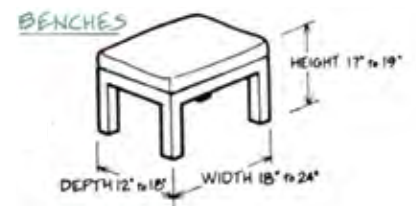
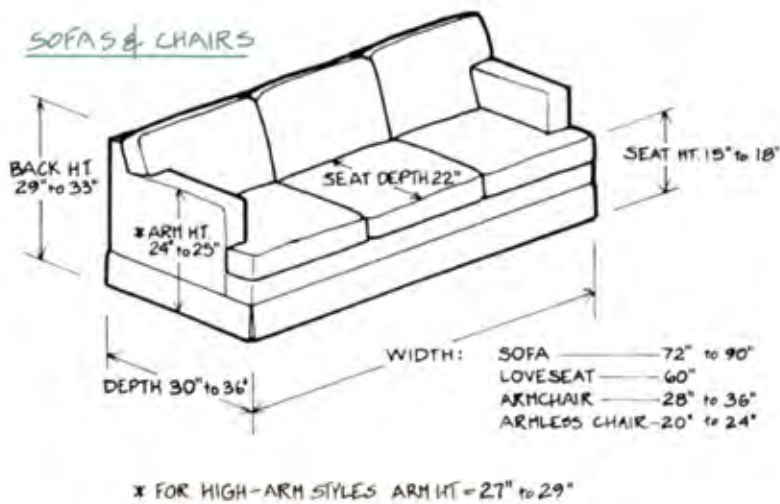

TYPICAL HEIGHTS OF OCCASIONAL TABLES



STYLE CHART: CHAIRS

CLUB CHAIR



high-arm,
loose boxed cushions,
tapered legs

CLUB CHAIR



low-arm,
loose t-cushions,
upholstered base

CLUB CHAIR



wide tapered arms,
recessed base

CLUB CHAIR



roll-arm,
skirt w/reverse pleats,
boxed cushions

SLIPPER CHAIR



boxed cushions,
skirt w/reverse pleats

SLIPPER CHAIR



parsons legs,
knife-edge cushions

SPLIT-BACK CHAIR



shirred skirt
w/one inch header

SPLIT-BACK CHAIR



upholstered base
w/one inch toe space

MARSHALL FIELDS CHAIR



button-tufted back
skirt w/reverse pleats

BARREL-SHAPED CHAIR

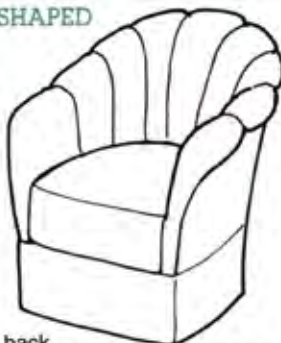

channeled back,
skirt w/soft rounded corners, no pleats

Round-back chairs fall into general categories depending on how the fabric is seamed or fastened to the inside curve of the back. In some cases modern stretch-fabrics are used to eliminate any seams or buttons.

Swivel bases or recessed castors are frequently used on any of these chairs.

BARREL-SHAPED CHAIR



utilizing stretch-fabric
to eliminate seams

STYLE CHART: SOFAS

ST. THOMAS SOFA

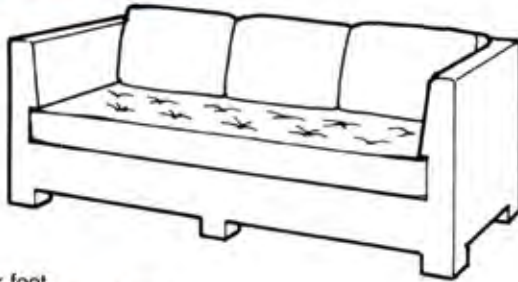

block feet,
undercut tapered arms,
tufted single seat cushion

TUXEDO SOFA



straight, square high arms,
loose boxed seat and back cushions

LAWSON SOFA



round arms,
semi-attached back cushions

LAWSON SOFA



square arms,
loose t-cushion seat,
loose pillow back

ROLL-ARM SOFA

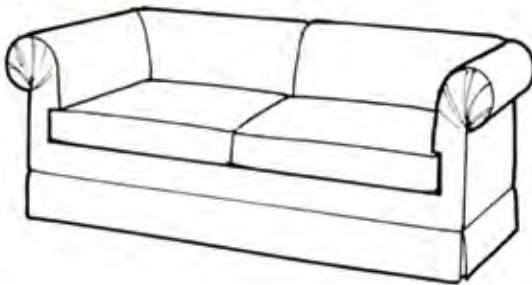

high rolled arms and back

ROLL-ARM SOFA

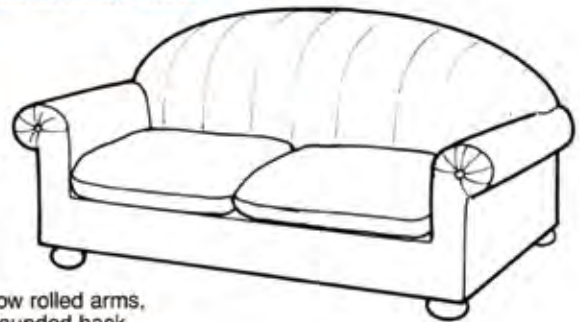

low rolled arms,
rounded back,
bun feet

ROUNDED SOFA

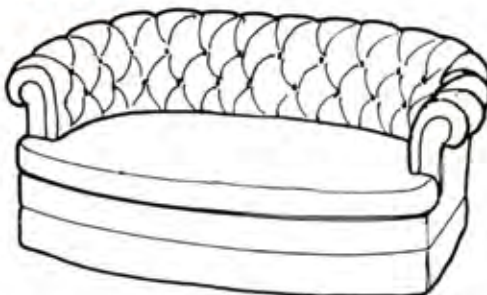

button-tufted back

ROUNDED SOFA

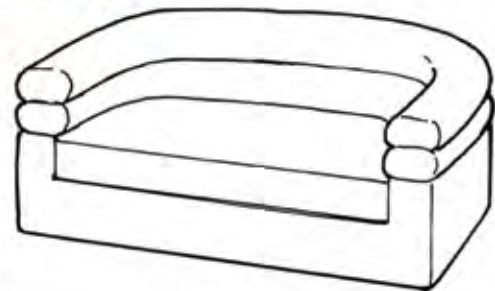

split back

ITALIAN MODERN SOFA



semi-attached pillow seat, back and arms

ARMLESS SOFA



block feet

SECTIONAL



many variations of base and cushion details are possible

STYLE CHART: CHAISES AND DAYBEDS

CHAISE

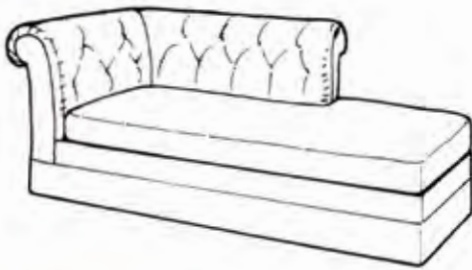

tufted, rolled arm and back

CHAISE

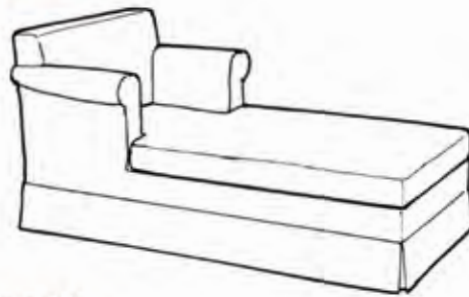

lawson style
skirt w/reverse pleats

ARMLESS CHAISE

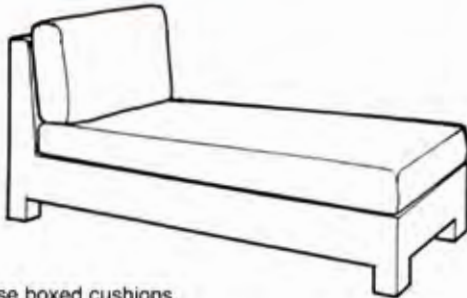





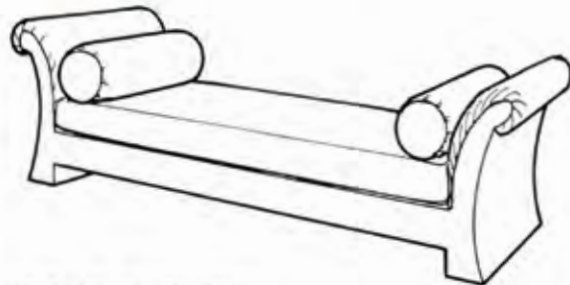



loose boxed cushions,
block feet

DAYBED

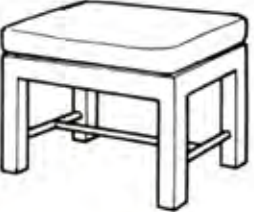

rolled ends, round bolsters

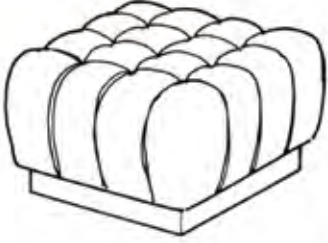
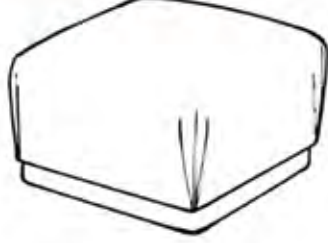
STYLE CHART: BENCHES AND OTTOMANS

<p>PARSONS BENCH</p>  <p>w/semi-attached cushion</p>	<p>PARSONS BENCH</p>  <p>w/tight upholstery</p>	<p>PARSONS BENCH</p>  <p>w/central stretcher</p>
<p>BENCH WITH SHIRRED SKIRT</p> 	<p>X-LEG BENCH</p> 	<p>WATERFALL BENCH</p> 
<p>BOXED OTTOMAN</p>  <p>skirt w/reverse pleats, semi-attached cushion</p>	<p>TUFTED OTTOMAN</p>  <p>recessed base</p>	<p>TIGHTLY UPHOLSTERED OTTOMAN</p>  <p>recessed base</p>
<p>POUF</p>  <p>semi-attached cushion</p>		<p>POUF</p>  <p>tight upholstered top</p>

DETAILS CHART: CUSHIONS

BOXED CUSHION,
NO WELTS

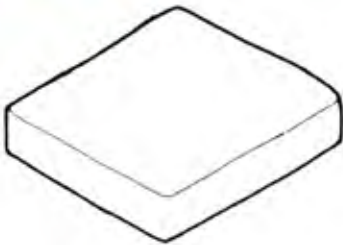

KNIFE-EDGE CUSHION,
NO WELTS



TURKISH CORNERS



BOXED W/WELTS



KNIFE-EDGE CUSHION W/WELTS



BUTTON TUFTED

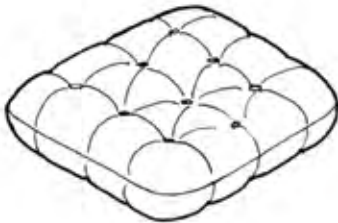

LOOSE CUSHION SEAT & BACK

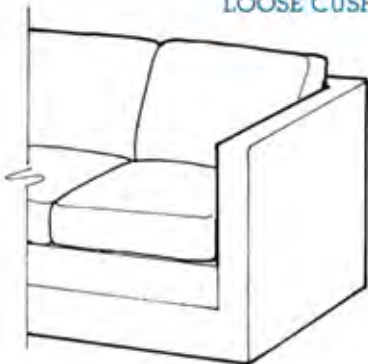

LOOSE T-CUSHIONS

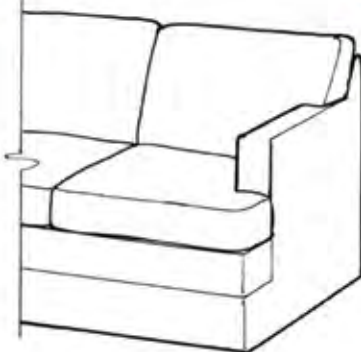

UNDERCUT ARM



SIDE BOLSTER

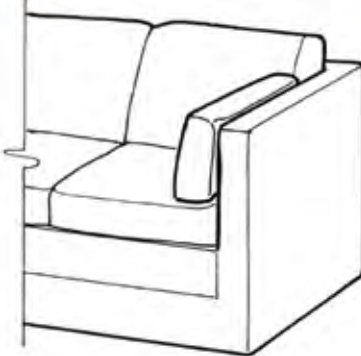





New York
Institute of
ART+DESIGN

ASID1LSN6.indd