

**DESIGN MANUAL
FOR A BARRIER- FREE
BUILT ENVIRONMENT**



December 2004

**DESIGN MANUAL
FOR A BARRIER- FREE
BUILT ENVIRONMENT**



FOREWORD

PUBLISHER’S NOTE

PREFACE

THE TEAM

INTRODUCTION

01- SIGNAGE _ page 03 - 14

1.1 - Introduction (Sign Types)

1.2 - Design Considerations

1.2.1 - General

1.2.2 - Signage Requirement

1.3 -Specifications

1.3.1 - Character Proportion

1.3.2 - Character Height

1.3.3 - Raised / Brailled Characters and Pictograms

1.3.4 - Finish and Contrast

1.3.5 - Mounting Location and Height

1.3.6 - Symbols of Accessibility

1.3.7 - Illumination Levels

1.4 - Signage Design

1.4.1 - Language

1.4.2 - Sign Typeface

1.4.3 - Suggested Sizes for Letters and Symbols

1.4.4 - Text Design

1.4.5 - Colour and Contrast

1.5 - Sign Installation

1.5.1 - Illumination

1.5.2 - Sign positioning

02- BASIC ANTHROPOMETRICS_page 15 - 21

2.1 - Reach Ranges

2.1.1 - Forward Reach

2.1.2 - Side Reach

2.2 - White Cane Range

2.3 - Common Reach Zone

2.4. - Circulation Dimensions

2.4.1 - Wheelchair Dimensions

2.4.2 - Walkway Width for Crutch Users

2.5 -Vision Cone

2.6 - Heights of People

2.7 - Lighting

03- SPACE ALLOWANCES _ page 22 - 26

3.1 - Minimum Access Provisions

3.2 - General Allowances

3.2.1 - Wheelchair Passage Width

3.2.2 - Width for Wheelchair Passing

3.2.3 - Wheelchair Turning Space

3.3 - Clear Floor or Ground Space for Wheelchairs

04- ACCESSIBLE ROUTES _ page 27 - 50

4.1 - Physical Parameters

4.1.1- Location

4.1.2 - Width

4.1.3 - Passing Space

4.1.4 - Head Room

4.1.5 - Slope

4.1.6 - Changes in Levels

4.1.7- Guiding Blocks

4.1.8 - Signage

4.2 - Protruding Objects

4.3 - Ground and Floor Surfaces

4.3.1 - Surface Textures

4.3.2 - Levels

4.3.3 - Carpets

4.3.4 - Gratings

4.3.5 - Guiding Blocks (Detectable Warnings)

4.3.5.1 - Walking Surfaces

4.3.5.2 - Vehicular Areas

4.3.5.3 - Reflecting Pools

4.4 - Vehicular -Parking and Passenger Loading Zones

- 4.4.1- Location
- 4.4.2 - Parking Spaces
- 4.4.3 - Passenger Loading Zones

4.5 - Curb Ramps

- 4.5.1 - Location
- 4.5.2 - Width
- 4.5.3 - Slope

4.6 - Ramps

- 4.6.1 - Slope and Rise
- 4.6.2 - Landings
- 4.6.3 - Clear Width
- 4.6.4 - Handrails

4.7 - Stairs

- 4.7.1 - Treads and Risers
- 4.7.2 - Nosing
- 4.7.3 - Handrails

4.8 - Elevators

- 4.8.1 - General
- 4.8.2 - Automatic Operation
- 4.8.3 - Hall Call Buttons
- 4.8.4 - Car Controls
- 4.8.5 - Audio & Visual Signals
- 4.8.6 - Raised and Braille Characters on the Hoist- Way Entrances
- 4.8.7 - Door Delay for Car Calls
- 4.8.8 - Specifications for Car Dimensions
- 4.8.9 - Floor and Wall Specifications for the Car
- 4.8.10 - Illumination Levels

4.9 - Platform Lifts / Wheelchair Lifts

- 4.9.1- Lift Size
 - 4.9.2 - Vertical Movement Platform Lifts
 - 4.9.3 - Inclined Movement Platform Lifts
-

4.10 - Handrail Requirements

- 4.10.1 - Handrail Form
- 4.10.2 - Handrail Placement
- 4.10.3 - Handrail Texture

05- ENTRANCES _ page 51

5.1 - Mandatory

5.2 - Suggestive

06- DOORS _ page 52 - 58

6.1 - Door Clearances

6.2 - Door Hardware

6.3 - Suggestive

07- WINDOWS _ page 59

**08- WASH / BATHROOM
AND SHOWER AREA _ page 60 - 72**

8.1 - Toilet Cubicle

8.2 - Water Closets

8.3 - Bathtubs

8.4 - Washbasins

8.5 - Urinals

8.6 - Washroom Accessories

09- DRINKING WATER FOUNTAINS _ page 72

10- KITCHENS _ page 73 -75

10.1- Mandatory

10.2 - Suggestive

10.3 - Service Counters**11- STORAGE _ page 76 - 77****11.1 - Clear Floor Space****11.2 - Height****12- TELEPHONES _ page 78 - 80****12.1 -Clear Floor or Ground Space****12.2 - Controls****12.3 - Mounting Heights****12.4 - Protruding Objects****12.5 - Hearing Aid Compatible
and Volume Control Telephones****12.6 -Telephone Books****12.7 - Cord Length****12.8 - Text Telephones****13- FIXED OR BUILT-IN FURNITURE
(SEATING, BENCHES, TABLES)_ page 81****14- AUTOMATED TELLER
MACHINES _ page 83 - 84****14.1- Clear Floor Space****14.2- Reach Ranges****14.2.1 -Forward Approach Only****14.2.2 -Parallel Approach Only****14.3 - Controls****14.4- Equipments for Persons with Vision
Impairments****14.5 - Exceptions**

15 - ALARMS _ page 85 - 86

15.1- Location

15.2- Audible Alarms

15.3 -Visual Alarms

15.4- Auxiliary Alarms

**16- GENERAL CONTROLS AND
OPERATING MECHANISMS**_ page 87 - 88

16.1 - Clear Floor Space

16.2 - Height

16.3 - Operation

16.4 - Exceptions

REFERENCES _ page 89

ABOUT THE ORGANISATIONS_ page 90 - 92

CONTACT DETAILS _ page 93

APPENDIX _ page 94 - 100

**PARTNERS IN ACCESSIBILITY
MOVEMENT** _ page 101

X

E

D

N

I

FOREWORD

Disability is not a phenomenon but is a phase. Everyone at one point or the other passes through such phases. The elderly, ill, pregnant, obese, children, persons with fracture or with luggage could all be described as passing through a phase of disability. Even during such phases each one has the right to live in dignity. Accessibility, therefore, cannot be an aspect of sympathy but is very much the right of every individual. Barrier-free design, therefore, is a professional obligation as well as a societal commitment of design professionals.

Though unintended, most of our buildings today remain inaccessible to many. This is largely due to the lack of conscious efforts, concerns for the disabled and lack of basic information on what constitutes an accessible design. A universal design, not remaining synonymous only with the provision of ramps, involves many more aspects

to consider. This neither implies an additional demand nor involves an extra cost, if integrated right from the conception of the design. With this premise it is imperative to compile a comprehensive reference document that stipulates necessary provisions for universal designs – especially the space design. While numerous references are available, they tend to be disparate and not entirely compatible with Indian conditions.

I am glad that with sincere efforts from NGOs and architects, this detailed comprehensive and indigenous manual for a barrier-free built environment is realised. This should prove to be an authentic reference document. A must for architects, interior designers and space planners. To be kept alongside the measuring scale.

Balkrishna Doshi
Architect-Planner

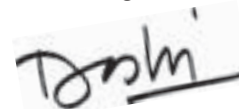

FOREWORD

It is my pleasure to endorse this reference manual for designers to make our built environment barrier-free and accessible to all. This effort aims to bring about awareness of the issues faced by the physically challenged people when using public buildings and spaces. It also incorporates concerns of the elderly, children and of people facing temporary mobility problems.

We, as committed and concerned professionals, should take up this responsibility of addressing these issues and demonstrate through our work the benefits of a barrier-free environment. Access to public areas is not only a matter of dignity but also the fundamental right of every person in our country.

I sincerely call upon the architects and urban planners to understand, advocate and use these simple design strategies, as demonstrated in this Manual, to make our buildings and cities a place which is accessible and safe for all.

Our firm, HCPDPM Pvt. Ltd. will continue lending its support for this cause and ensure that accessibility requirements are integrated into our design process.

Hasmukh C. Patel
Architect



PUBLISHER'S NOTE

UNNATI-Organisation for Development Education and Handicap International (HI), in collaboration with other partners and stakeholders, have been working towards invoking civil society participation to facilitate social inclusion and democratic governance. The aim is to empower the vulnerable sections of our society to enable them to effectively participate in mainstream development and decision-making processes. This includes people with disabilities and issues related to disability. While working on issues of disability in the past 3 years, we realised that, besides social and attitudinal barriers, physical obstacles in the environment pose a major hurdle in inclusion and, together, these barriers result in non-participation and exclusion.

The initiative in improving accessibility in Gujarat was taken in March 2003. An access awareness meeting was held at Law Garden, a popular public park in Ahmedabad city, to raise the awareness of civil society on accessibility and facilitate the involvement of various stakeholders. Jointly organised by the

Blind People's Association (BPA) Handicap International, and Unnati, the meeting was attended by senior architects, planners, designers, policy makers, academics, the media, persons with disabilities, NGOs and other stakeholders.

Following the positive response received after this meeting, a series of workshops were organised in Ahmedabad and Vadodara at the end of July 2003. 'Samarthya' – a group in New Delhi working on accessibility – was invited to Gujarat to interact with the above stakeholders as well as representatives from the service industry such as banks, hotels, entertainment and tourism. As a result of these workshops, many professionals decided to come together and form a Resource Group. This group took up the responsibility of promoting a barrier-free environment in the State and coordinate the various activities related to accessibility. To build the capacity of the group to audit buildings and spaces, an audit training workshop was organised in March 2004 with the support of Samarthya.

As the group undertook several access-related activities, it realised the need for developing clear and concise technical design guidelines for creating barrier-free spaces. A process that started in October 2003 culminated in this design manual.

During this entire process, for the first time perhaps, groups which rarely get a chance to work together came on to a common platform and shared a common objective – promoting a barrier-free environment. Both the users and service providers got an opportunity to interact, develop an understanding about each other's requirements and develop plans to promote social inclusion.

We thank the members of the Barrier- Free Manual Team - the authors of this handbook and their organisations – Vastu Shilpa Foundation, Environmental Planning Collaborative, HCP Design and Project Management Pvt. Ltd.– not only for sparing their valuable time and effort but also for their wholehearted commitment to the cause.

We also thank the members of the Access Resource Group for their support for and commitment to the accessibility movement.

We would also like to express our heartfelt thanks to Mr. Kamal Mangaldas for his encouragement and support and helping us take our first steps towards accessibility.

UNNATI team

Binoy Acharya
Arindam Mitra
Deepa Sonpal
Geeta Sharma
Shankharupa Damle

Handicap International team

Archana Shrivastav
Mahesh Dayalan
D Nanda

PREFACE

Today accessibility for all is recognised as a basic necessity and there are attempts all over the world to ensure this. Barrier-free features are now becoming fundamental to all design concepts.

This Manual seeks to provide clear and concise guidelines that can help design a built environment as barrier-free and accessible. This is our first attempt at putting together a set of guidelines that take into consideration firsthand experiences of people with difficulties / disabilities and local conditions. This Manual, thus, is more a prototype than a final product. We are sure that with an extensive use of this handbook and feedback from users, further editions, more user specific, will follow. Further, at the moment, this Manual deals mainly with urban built spaces and environment. This handbook has been the labour of love for many of us who sincerely believe that our

environment must be barrier - free and accessible to all and that, this is easily achievable.

We acknowledge the continued support of Anjlee Agarwal and Sanjeev Sachdeva of Samarthya, New Delhi, in promoting accessibility. They have been our inspiration and the catalysts for the entire process of compiling these guidelines.

We also express our thanks to the many people who have given their input for this Manual, especially Dr. Bhushan Punani, Ms. Nandini Rawal and other friends from the Blind People's Association, Ahmedabad, Prof S. Balaram of the National Institute Of Design, Ahmedabad, and B. R. Balachandran of Environmental Planning Collaborative, Ahmedabad.

THE BARRIER-FREE MANUAL TEAM

Sweta Byahut

Environmental Planning Collaborative,
Ahmedabad

Anagha Mujumdar, Anand Patel

HCP Design and Project Management, Ahmedabad

Amit Sheth

Mind's Eye Design, Ahmedabad

Arindam Mitra

UNNATI – Organisation for Development
Education, Ahmedabad

Raajesh Moothan, Yatin Pandya

Vastu Shilpa Foundation for Studies and Research
in Environmental Design, Ahmedabad

Any part of this Manual may be copied with due acknowledgement.

First Edition December 2004 1000 Copies

Research

Anagha Mujumdar, Anand Patel, Arindam Mitra,
Raajesh Moothan, Sweta Byahut, Yatin Pandya

Text Editing

Arindam Mitra, Raajesh Moothan

Layout and Book Design

Raajesh Moothan, Yatin Pandya

Illustrations Drafting

Anagha Mujumdar, Anand Patel, Kahan Vyas

Printer

Bansidhar Offset, Ahmedabad

Publisher

UNNATI – Organisation for Development Education,
Handicap International

Reprint November 2006 1000 Copies

INTRODUCTION

A Background To The Barrier-Free Concept

Over the years, our society has slowly done away with segregations into divisions and has started amalgamating itself to become more global and encompassing. The differences and discriminations due to caste, creed, colour, sex, profession, etc. are slowly disappearing and society is moving towards becoming a more inclusive one – where all are included and perceived as equals.

The world today has become a very small place—a world with virtually no frontiers or barriers. Especially after the advent of Internet and total connectivity, people have instant access to almost every imaginable service or information. A truly global village. In spite of the world and our society being more inclusive, more connected and accessible to all, it is unfortunate

that in reality some barriers still exist – especially physical barriers which deny access to people with differences such as persons with disabilities, the elderly, children and pregnant ladies, persons with temporary or permanent difficulties. These barriers result in denying them their rights and opportunity to full participation and eventually culminate in their exclusion from society.

In this background, many countries, especially the more developed ones, acknowledged the need for removing barriers and making places accessible. The movement started gathering momentum in the late 1970's and initially focused on barriers faced by injured war veterans and other people with disabilities. This led to legislation and Disability Acts in these countries. However, as the concept became popular and clearer, it was realised that barriers were a

problem faced not only by people with disabilities but also by many sections of society such as the elderly, pregnant ladies, children and temporarily incapacitated people. This realisation led to many Disability Acts being revised and made universal. With barrier-free design becoming a fundamental part of all planning, many countries have taken major strides towards making access universal. In India, the process is at an initial stage and has a long way to go before there is a general concerted move to create accessibility.

A major step has been the PWD Act 1995 that specifies the law and the role of the State in creating access. Over and above, the National Building Code, CPWD guidelines as well as bylaws of various urban development bodies have shown the direction towards building a barrier free environment. A small note is given later in this handbook.

What is a Barrier-Free Environment?

A barrier-free environment is a space that allows for free and safe movement, function and access for all, regardless of age, sex or condition. A space or a set of services that can be accessed by all, without obstacles, with dignity and with as much independence as possible. The environment means buildings, roads, parks, gardens and other places, services, modes of transportation, products of daily use, etc. There is a popular belief that a ramp and an elevator/lift is all that is needed to make a built space barrier-free.

It must be clearly understood that barrier-free goes far beyond just a ramp and has many other necessary aspects. These range from door and passage widths to flooring surfaces, from counter heights to door handles and railings, from signage and auditory signals to tactile guides.

Who all face barriers?

On the face of it, it is only persons with disabilities for whom barriers become major obstacles. However, it is necessary to realise that every person, at some stage of life, faces barriers. A small child, an elderly or infirm person, a pregnant lady, the temporarily disabled, all are vulnerable to barriers. Therefore, to list out people affected by barriers -

- Wheelchair users
- People with limited walking/ movement abilities
- People with visual impairment or low vision
- People with hearing impairment
- Elderly and infirm persons
- Pregnant ladies
- Children
- People with temporary disabilities

Why is it necessary to remove barriers?

Barriers make an environment unsafe and cause a high level of difficulty to the user. But more importantly, barriers cause spaces to be out of reach, denying people the opportunity of participation in various spheres of life. This ranges from education, economic, social, cultural and many other activities. This loss of opportunity is not only a loss for the person concerned but also society's loss which misses out on their contribution. Simply put, a barrier causes exclusion and its removal is necessary for ensuring inclusion and participation of all in society.

Access is a basic right

A barrier-free environment is a basic right of all. It is not a matter of choice or option. Ensuring access is a basic social necessity benefiting all.

Not allowing a person equal opportunities and participation is an infringement on his/her rights as a citizen of this country.

“Universal Design” or “Design for All”

Throughout the world it is being realised that there need not be an exclusive design effort to suit the needs of people with differences. One proper design, which keeps in mind all the requirements, can work for all. For example, if a door is wide enough to allow passage of wheelchair or crutch users that door is good enough for all persons.

Designing therefore should focus on being universal rather than fulfilling separate needs. A single design not only helps in controlling space and expense but also reduces exclusion and promotes inclusion.

Simply put, a universal design means there are no differences between people. It integrates and does not differentiate.

The Rationale for this Manual

During 2003, a committed group, which consists of members and advisers from various stakeholder groups such as architects and town planners, NGOs, institutions, designers, etc., came together to actively promote accessibility in Gujarat.

During the groups' activities and various access audits, it emerged that there is an urgent need for clear and concise technical design guidelines for barrier-free spaces.

There are many sets of guidelines already existing all over the world, including India. Some

of these are : the UN Standards, the US-ADA Guidelines, the UK Guidelines, closer home the CPWD Guidelines, the National Building Code and various urban authorities' bylaws and guidelines.

The problems of plenty are evident in this that each of these manuals, depending upon their place and source of origin, adheres to different guidelines and measurements. They have varying sets of parameters and are not tailored for the Indian conditions.

Thus, even with these in circulation, there is need for one manual which co-relates the dimensions and giving dimensions suited by the target group, simultaneously keeping in mind the constraints faced by the architects and designers.

Explicitly Stated :-

- Different guidelines gave varying sets of parameters. Though the variance was not very high, yet it was leading to confusion during actual designing. Over and above, the question always was – which guidelines to follow?
- Most of the guidelines in use were of international origin. There was a felt need of guidelines adapted to Indian conditions and tailored to local needs.
- It was also felt that the actual experiences of people with differences and the barriers they face need to be incorporated .
- Most designers had expressed the need for concise, clear and easy-to-use guidelines.

With this background, need and rationale, this particular design manual has been compiled.

THE MANUAL

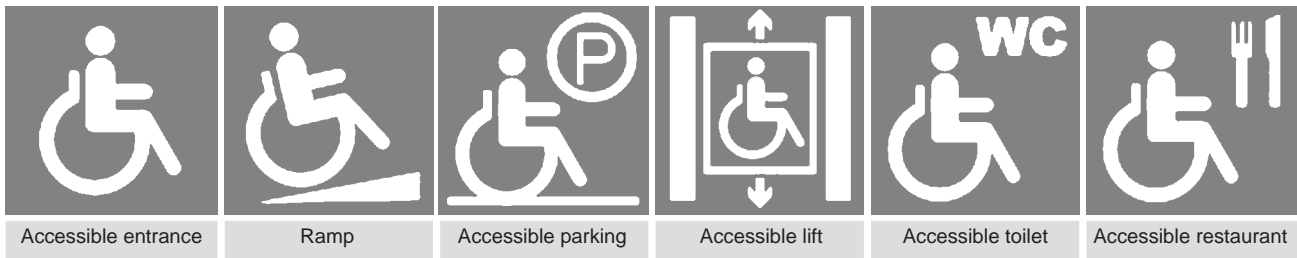

					
Accessible telephone	Accessible to spectators	Accessible taxi	Accessible bus stop	Information	Other facilities
		 Braille			
Facility for vision impaired	Access to low vision	Braille symbol	Working dog welcome	Staff trained to help	Audio description
					
Assistive hearing system	Induction loops used	Sign interpretation	Telephone typewriter	Volume control telephone	Closed captioning

01- SIGNAGE

1.1 - INTRODUCTION (SIGN TYPES)

-There are four main functional typologies into which signage could be classified :

- a. Information Signs
- b. Directional Signs
- c. Identification (Locational) Signs and
- d. Warning (Safety) Signs.

Information Signs

-These include location signs, sign directories, maps for both internal and external areas for orientation of the user.

Direction Signs

-These signs direct the user to a destination with arrow marks aiding the text.

Identification Signs

-These signs installed at specific individual destinations indicate the location of a room, service, desk, etc.

Warning (Safety) Signs

-Signs installed for the safety of users which may be either the warning or the prohibitory type . This group would include fire exit signs, safety signs, etc. and are normally specified by I S O conventions in terms of colour, size and graphic. These designs should be adhered to and not tampered with in any aspect.

-The graphic qualities of each type depends upon the intensity of the message and must conform to them universally to avoid ambiguity. In places used extensively by persons with a particular disability, the signage should be appropriately altered to suit them. Signage forms an important part in creating a barrier-free environment and should be treated as such.

-The following internationally specified shapes should be followed in signboards for various signs:

Information signboards – Rectangular

Warning signboards – Triangular

Interdiction signboards – Circular

1.2 - DESIGN CONSIDERATIONS

1.2.1 - General

-Signage should be placed at nodal positions, openly and prominently. They should be simple in syntax and must be well lit in ambient low-light conditions.

-It should not obstruct any movement path and, if suspended, should have a minimum clear head-room of 2000 mm from the finished floor.

-If the signage is floorbased and free-standing, then there should be a detectable barrier at the floor level for the white stick users.

-Signage systems should be clear, consistent and in all the comprehensible languages of the region. Cross signage should be avoided to avoid anxiety and confusion.

-In general, signs should not be placed behind glass panels because of possible reflection and thus making for poor readability.

-Signage placed on pedestrian path of travel are considered obstructions; thus they should be detectable.

1.2.2 - Signage Requirement

-Signs related to barrier-free access are required at the following locations:

-An exterior sign complying with Sections 1.1 and 3 should be located at the main accessible entrance.

-In the case of multiple access points, each access point should indicate the shortest route to the accessible entry.

-Reception areas and lobbies should have locational signs for elevators, fire exits, accessible facilities like toilets, etc., directional and locational signs for major services like cafes, reception, public telephone, etc., emergency signage. In each case, the accessible route should be marked to avoid confusion.

-Sign directories and maps showing accessible routes should be provided for extensive campuses.

-Each floor should have directional signs to

accessible facilities and exits, emergency signages and a sign directory or information signs at main intersections.

-Accessible spaces and facilities should be identified by the international symbol of accessibility. (fig.1)

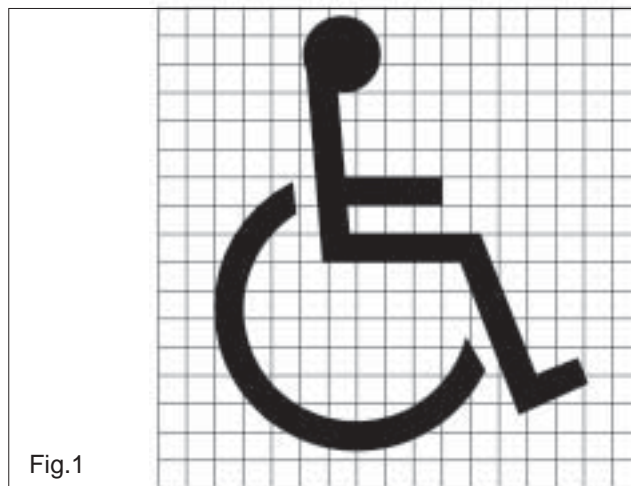

Fig.1

1.3 -SPECIFICATIONS

-The following specifications should be adhered to while designing signages.

1.3.1 - Character Proportion

-Letters and numbers on signs shall have a width-to-height ratio between 3:5 and 1:1 and a stroke-width-to-height ratio between 1:5 and 1:10. (fig.2)

1.3.2 - Character Height

Characters and numbers on signs shall be sized according to the viewing distance from which they are to be read. The minimum height is measured using an upper case 'X'. Lower case characters are permitted. The smallest letter type should not be less than 15mm. The size of the letters should be in proportion to the reading distance. (fig.3)

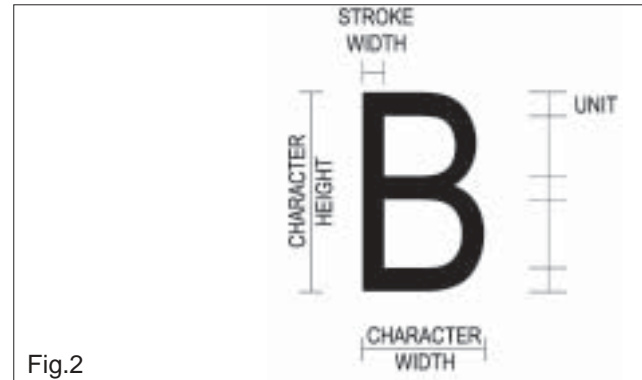

Fig.2

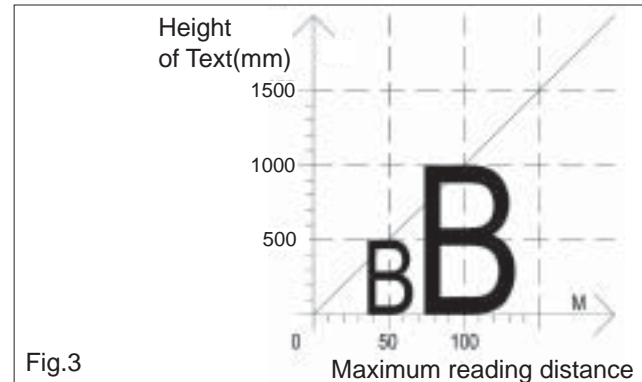

Fig.3

1.3.3 - Raised and Brailled Characters and Pictograms

-The letters and signs should preferably be raised or etched at least 1 mm from the background, to enable sightless people to read the information using the tips of their fingers. Raised characters shall be at least 15 mm high, but not higher than 50 mm. Pictograms shall be accompanied by the equivalent verbal description placed directly below the pictogram. The border dimension of the pictogram shall be 150 mm minimum in height.

1.3.4 - Finish and Contrast

-The characters and background of signs shall be eggshell, matte, or other non-glare finish. It is preferable to also use light-sensitive reflective surfaces which would reflect incident light (radium stickers).

-Characters and symbols shall contrast with their background — either light characters on a dark background or dark characters on a light background. The commonly used colours are: white, black, yellow, red, blue and green.

-The colour combinations red/green and yellow/blue should not be used in order to avoid confusing colour-blind persons. (They are complementary colours).

1.3.5 - Mounting Location and Height

-Where permanent identification is provided for rooms and spaces, signs shall be installed on the wall adjacent to the latch side of the door. Where there is no wall space to the latch side of the door, including at double leaf doors, signs shall be placed on the nearest adjacent wall. The mounting height shall be 1500 mm from finished floor to centreline of the sign.

The mounting location for such signage shall be such that a person may approach within 76 mm of them without standing within the swing of a door or encountering protruding objects. Overhanging signs should have a minimum clearance of 2000 mm from finished floor. (fig.29)



Fig.4

1.3.6 - Symbols of Accessibility

-Facilities and elements required to be identified as accessible shall use the international symbol of accessibility. The symbol shall be displayed as shown in fig.1 . The symbol may be adapted to individual facilities as shown in fig.5,6,7. Palletes of universally adopted symbols are given on page 1 and 2.

-The symbol is composed of a wheelchair figure with either a square background or a square border. (fig. 6)



Fig.5



Fig.6

-Contrasting colours should be used to differentiate the figure from the background. The commonly employed colours are white for the figure and blue for the background.

-The wheelchair figure should always face the right..

-For completely accessible buildings, it is enough to have one explanatory sign at the entrance.

1.3.7 - Illumination Levels

-Illumination levels on the sign surface shall be in the 100 to 300 lux range and shall be uniform. Signs shall be located such that the illumination level on the surface of the sign is not significantly exceeded by the ambient light or a visible bright lighting source behind or in front of it.

1.4 - SIGNAGE DESIGN

1.4.1 - Language

-Clear, unambiguous messages in simple, understandable fonts and formats.

-Legibility improves if every key word begins with a capital letter.

-The exceptions are standard words like STOP, EXIT, BUS, etc.

-Use punctuations sparingly and avoid the use of full stops at the end of the sentence.

-Signages leading to two destinations should be kept on separate lines for easier legibility.

-Avoid abbreviations as they can be easily misinterpreted.

-Symbols should be used wherever possible. They are very useful for visually impaired people as they can be larger in size than the text message. A good pictorial symbol depends on simplicity, legibility and good recognition/ familiar factor. It also helps illiterate people to comprehend the signage.

-Where more than one language is to be used in a sign, it is advisable to use symbols as well.

-ISO-recommended symbols must be used as far as possible.

-The arrow in directional signs must be carefully used so as to aid and not confuse the user. This is more relevant when placing a directory of multiple directions. (fig. 5)



Fig. 7 : Some standard internationally recognised symbols for people with disabilities.

1.4.2 - Sign Typeface

-Sign typefaces must be standard, legible and clearly discernible. Some recommended typefaces are :

Sanserif

Arial
Avant-Garde
Futura
Grotesque
Helvetica

Serif

Baskerville
Bembo
Century Schoolbook
Times New Roman

-Decorative, fancy, expanded and condensed typefaces should be avoided. Also Italics or script texts are not very legible.

-Usage of too many type sizes on any one sign should be avoided.

- The size of the typeface must be in relation to the viewing distance.

1.4.3 - Sizes for Letters and Symbols

(Minimum character size)

-At building entrances, house numbers and similar : 150 mm

-Identification or direction signs : 50 ~ 100 mm

-Sign directories : 25~50 mm

-Symbols should be at least 100mm in height.

-Braille should be incorporated in the signs. Round dots which should be raised 0.46mm must be placed below the text (or symbol) and ranged from left.

- A Braille locator (either raised or recessed should also be incorporated in the sign to enable the visually impaired to be guided to the Braille message.

1.4.4 - Text Design

-Legibility also depends on inter character spacing, word spacing and line spacing.

-For visually impaired people it is desirable to increase the inter character, word and line spacing by 20 percent to 30 percent.

-Text aligned left is the easiest to read and is recommended in most cases except in direction signs where both left and right arrows are being used and the text should correspondingly be left or right aligned.

-Locational signs can be centre aligned.

-Both upper and lower cases must be used as they tend to be more legible than a message in all caps or all small letter forms.

1.4.5 - Colour and Contrast

-The colour and contrast should depend on external factors such as background, location, etc. A blue sign on a blue wall will obviously be of little help.

-A border around the sign can be useful in increasing the readability as long as the border width is not overpowering.

The chart (fig.8) on page 13 recommends some colour combinations:

Background	Sign Surface	Sign Text / Symbol
Brick, dark stone	White	Black / blue / green
Light brick or stone	Black / dark	White / yellow
Whitewash wall	Black / dark	White / yellow
Green vegetation	White	Black / blue / green

Fig. 8

1.5 - SIGN INSTALLATION

1.5.1 - Illumination

-All signs must be adequately lit for proper visibility. However, glare from lighting will cause discomfort. Signs must ideally be made from materials with a matt finish, should not be placed in front of glass or similar transparent material and should not be suspended against a light source with angle of incidence equal to $90\frac{1}{2}$.

1.5.2 - Sign Positioning

-All wall-mounted or free standing signs must ideally be positioned in the range of 1400 to 1600 mm above the finished floor level for proper readability. This is specially applicable to all signs that are to be read at close range e.g door signs, identification signs, etc.

- Room numbers should be placed on door frames and not on the doors so that they are visible even when the door is open. (fig.9)

- The room nameplate in Braille should be incorporated into the signage within a range of 1200 mm to 1400 mm. (fig.9)

-All hanging signs must be suspended at least 2000 mm from the finished floor level so as not to cause any obstruction to the user.

-All signs fixed flat on the wall must not project more than 100 mm from the wall.

-Signs that are to be read from a distance must be positioned sufficiently high so as not be covered by other objects such as people, cars, etc.

-Signs accompanied by a control panel (such as lift buttons) must be within easy reach of a

wheelchair user. The allowable range is 900 to 1200 mm above the finished floor level.

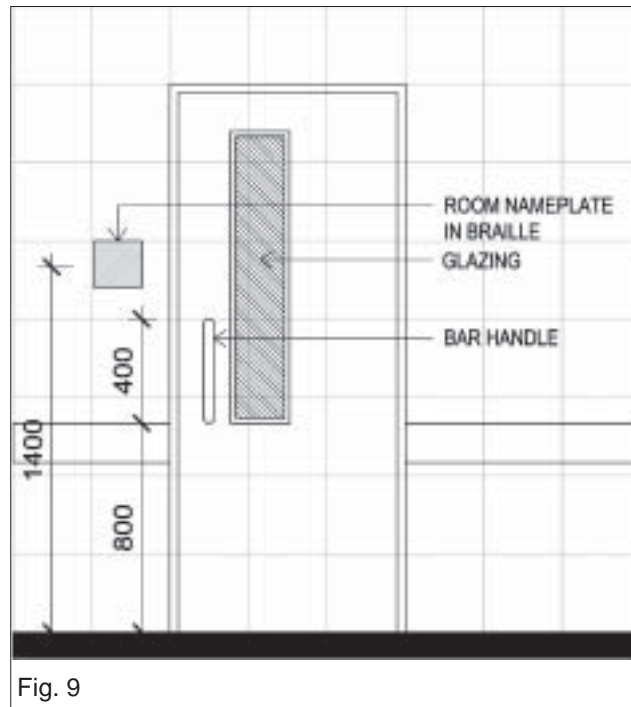

Fig. 9

02- BASIC ANTHROPOMETRICS

2.1 - REACH RANGES

2.1.1 - Forward Reach

-If the clear floor space only allows forward approach to an object, the maximum high forward reach allowed shall be 1200 mm. The minimum low forward reach is 400 mm. (fig.10)

-If the high forward reach is over an obstruction 500 mm deep the reach and clearances shall be 1100 mm. (fig. 11)

2.1.2 - Side Reach

-If the clear floor space reach allows parallel approach by a person in a wheelchair, the maximum high side reach allowed shall be 1300 mm and the low side reach shall be no less than 250 mm above the finished floor. (fig.12)

- If the side reach is over an obstruction 500

mm deep and 850 mm high, then the max. side reach is 1200 mm. (fig. 13)

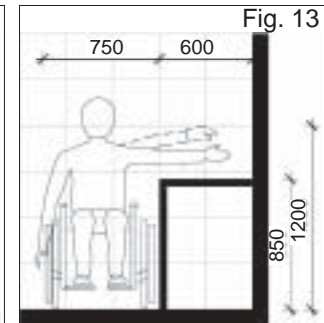
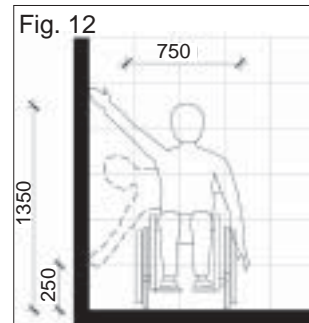
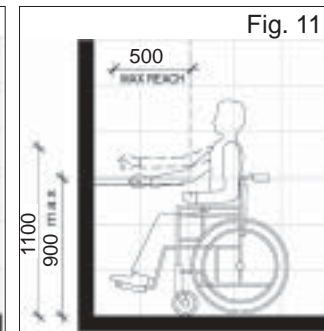
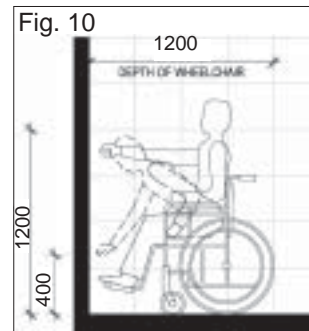

2.2 - WHITE CANE RANGE

-Any obstacle above 750 mm cannot be detected by the white cane. If there are projections above this height then the projections have to be reflected at the floor level in terms of level or textural differences. (fig. 14)

-The radial range of the white cane is a band 900 mm wide. (fig. 15)

2.3 - COMMON REACH ZONES

-The comfortable reach zone when seated on a wheelchair is between 900 mm and 1200 mm. The maximum reach zone is between 1200 mm and 1400 mm. (fig. 16)

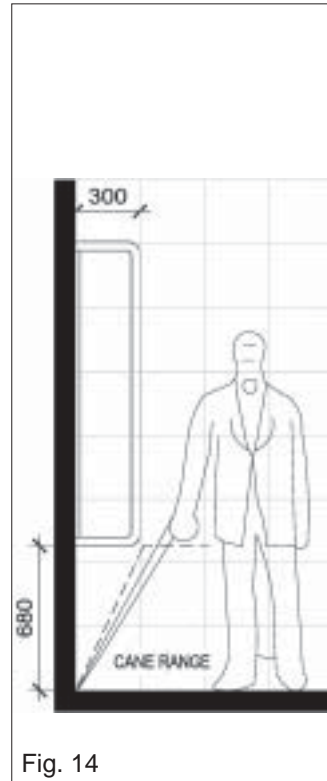

Fig. 14

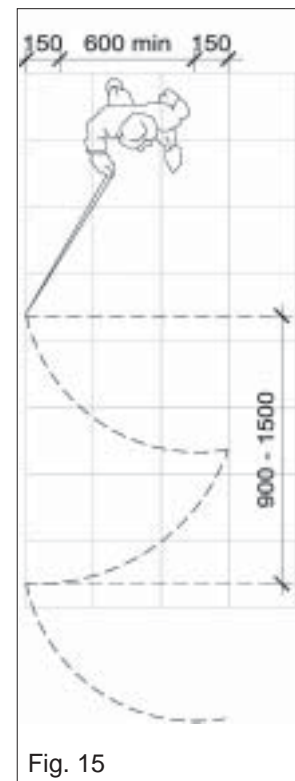
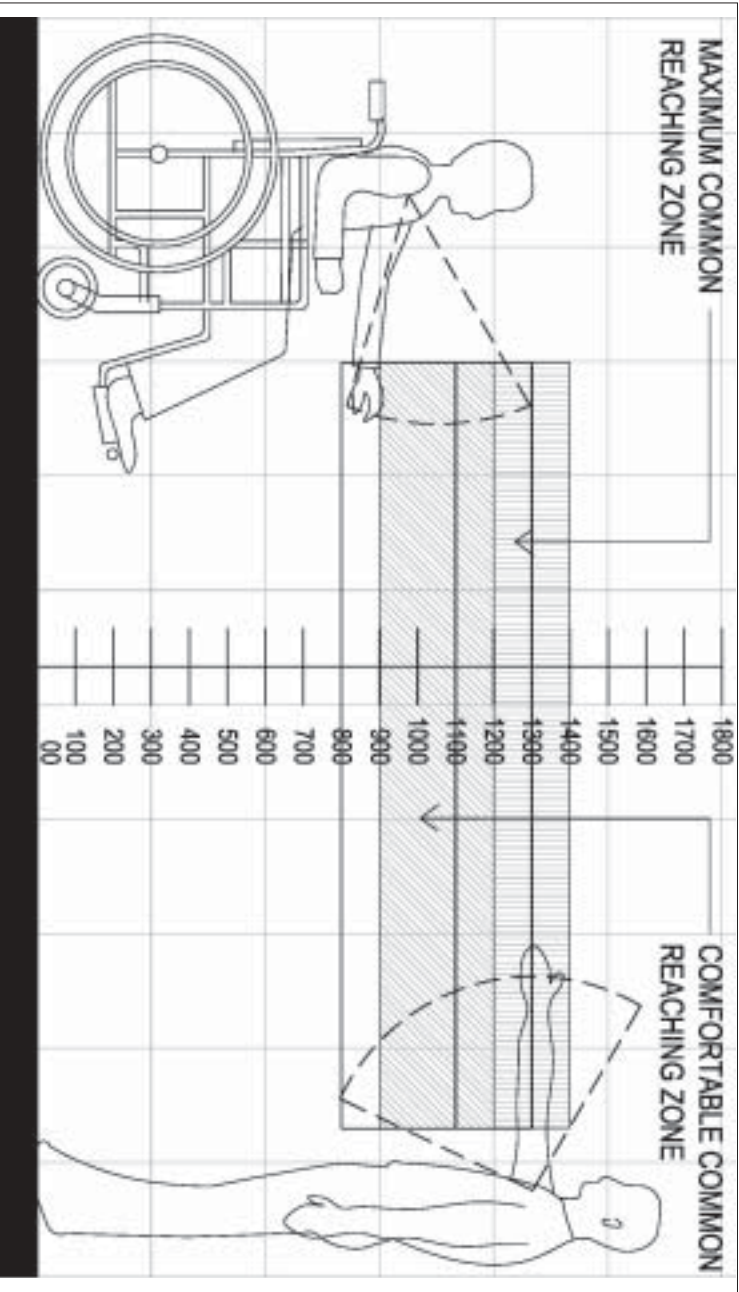

Fig. 15

Fig. 16



2.4 - CIRCULATION DIMENSIONS

Figure 19 illustrates that although 1500 mm is the minimum required turning radius, it is desirable to provide an 1800 mm turning radius.

2.4.1 - Wheelchair Dimensions

Figures 16, 17 and 18 illustrate some of the typical dimensions of the standard wheelchair. Electrical wheelchairs may be more bulky and do not have the same manoeuvrability as manual wheelchairs.

2.4.2 - Walkway Width for Crutch Users

Even though the disabled using walking aids can manoeuvre themselves through door widths of 900 mm., for a comfortable gait a wider passageway is desirable. A minimum width of 950 mm is desirable. (fig. 20)

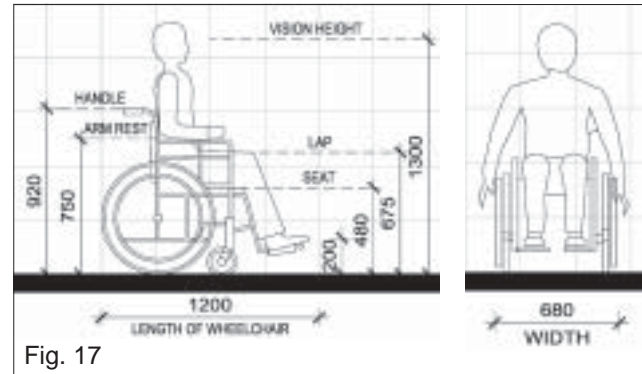

Fig. 17

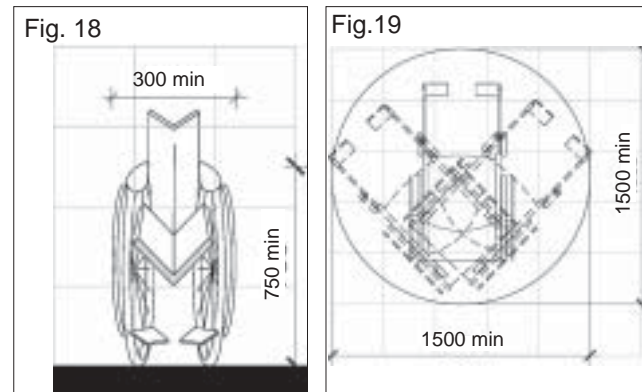

Fig. 18

Fig. 19

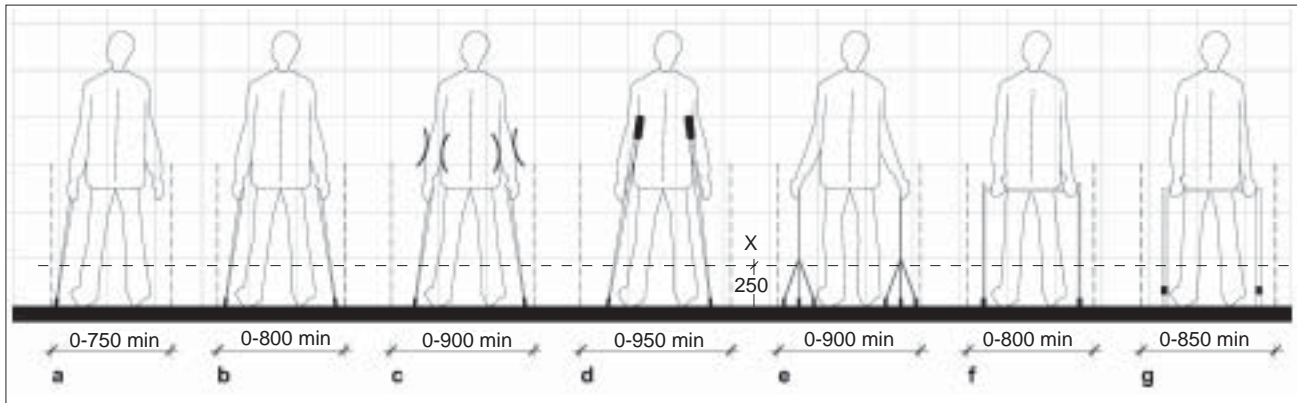

Fig. 20 - Passage-widths afforded by the various types of walking aids used by persons with locomotive disability.
X - No obstruction should project into this zone.

2.5 -VISION CONE

-The illustration aside shows the different fields of vision for the normal sighted person. All signages should be designed based upon these dimensions. (fig. 21, 22)

2.6 - HEIGHTS OF PEOPLE

-The average height of a person seated upon a wheelchair is generally less than 1200 mm.

-The average height of a standing person is generally less than 2000 mm.

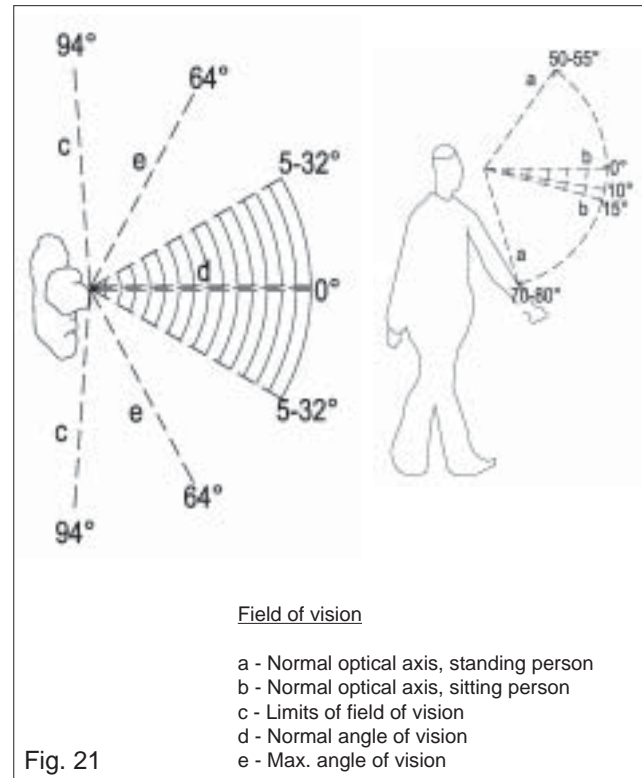

Fig. 21

2.7 - LIGHTING

-Illumination levels shall not be less than 100 lux in laboratories and not less than 50 lux in all other facilities.

-The minimum illumination level required at floor and tread level at angles, intersections and changes in level where there are stairs or ramps shall be:

- 50 lux in every exit, in every public corridor, and in every corridor providing access to an exit and other occupancies.

-100 lux in washrooms, in recreation rooms, residence common rooms, at the level of edge of stair nosings.

- 200 lux in service rooms and laundry rooms.

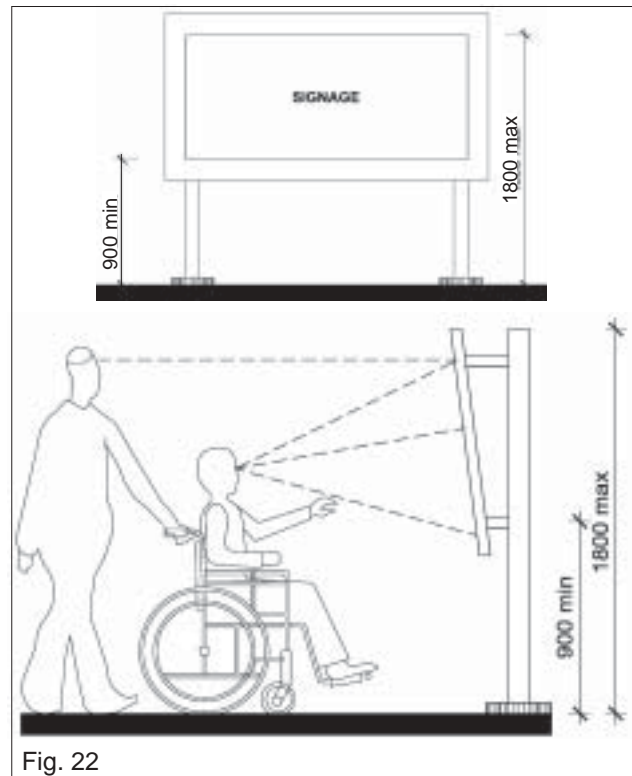

Fig. 22

03- SPACE ALLOWANCES

-Ideally all the buildings should be completely accessible. The following are the minimum access needs:

3.1 - MINIMUM ACCESS PROVISIONS

Type of Building	Minimum Provisions
-Single detached, single dwelling units	-A minimum of 2 per cent of the total number of units to be constructed with barrier-free features.(Adoptable units).
-Staff housing, multiple dwelling,high - rise dwelling units and tenements	-A minimum of 1 unit for every 25 units, whereafter 1 additional unit for every 100 units should be accessible. -The main entrances and exits must be accessible.
-Tenement houses, row houses, apartments and town houses	-A minimum of 1 unit for up to 150 units, whereafter minimum of 1 additional unit for every 100 units should be accessible. -The main entrances and exits must be accessible.
-Post offices, banks and financial service institutions	-A minimum of 1 lowered service counter on the premises -A minimum of 1 lowered Automatic Teller Machine (ATM). 1 cash disbursement point on the premises. Stamp vending machine.

-Shophouses and single-storey shops

-Accessible shopping area.

-Places of worship

-Entrance and exit and the main area of worship to be accessible.

-Mosques : Access to area for ablutions.

-Churches : Access to confessionals, fonts and chapels.

-Temples : Access to shrines and courtyards.

-Food centres

-A minimum of 1 table without stools or seats attached to the floor for every 10 tables. A minimum of 2 tables without stools or seats attached to the floor for the whole premises

-Community centres, village halls, auditoria, concert halls, assembly halls, cinemas, theatres and other places of public assembly.

-Accessible entrances, exits, aisles and main community or public gathering areas.

-Accessible toilet facilities should be near by.

-Seating for persons with disabilities should be accessible from main entrances and lobbies.

-Various seating/viewing choices to be provided for persons in wheelchairs throughout the main seating area.

-A minimum of 2 wheelchair spaces for a seating capacity of up to 100 seats and 4 wheelchair spaces for seating capacity from over 100 to 400 seats.

3.2 - GENERAL ALLOWANCES

3.2.1 - Wheelchair Passage Width

-The minimum clear passage width for a single wheelchair is 900 mm continuously. (fig.23). An accessible route should be 1200 mm wide to allow both a wheelchair and a walking person except where extra space is required at the doorways.

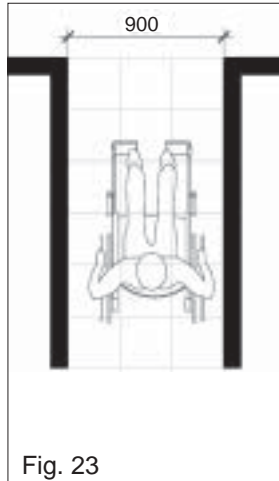

Fig. 23

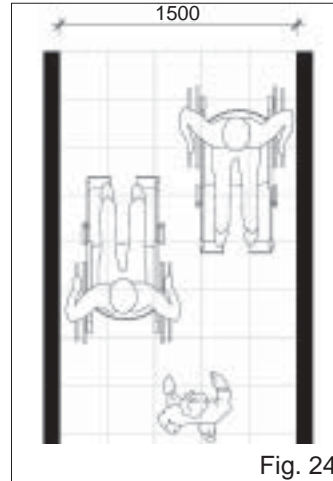

Fig. 24

3.2.2 - Width for Passing Wheelchairs

-The minimum passage width for two wheelchairs to pass side by side is 1500 mm. (fig.24). In case of continuous stretch of corridor, the preferable width is 1800 mm.

3.2.3 - Wheelchair Turning Space

-The minimum space required for a wheelchair to make a 180 degree turn is a clear space of 1500 mm diameter or a T-shaped space 900 mm. wide. (fig. 25)

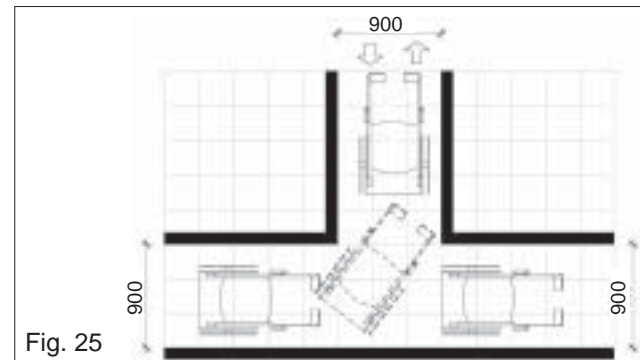

Fig. 25

3.3 - CLEAR FLOOR OR GROUND SPACE FOR WHEELCHAIRS

-The minimum clear floor or ground space required to accommodate a single, stationary wheelchair and occupant is 900 mm x 1200 mm. (fig.26) An allocation of 1200 mm x 1200 mm would facilitate both forward and side approaches.

-The clear floor or ground space for wheelchair access may be positioned for perpendicular or parallel approach to an object. (fig .26)

-This clear floor or ground space may be part of the knee space required under some objects such as tables, basins or platforms.

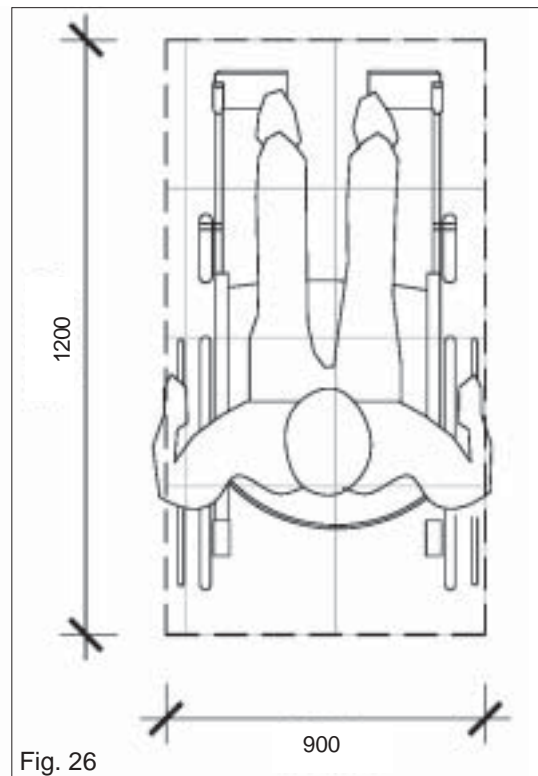
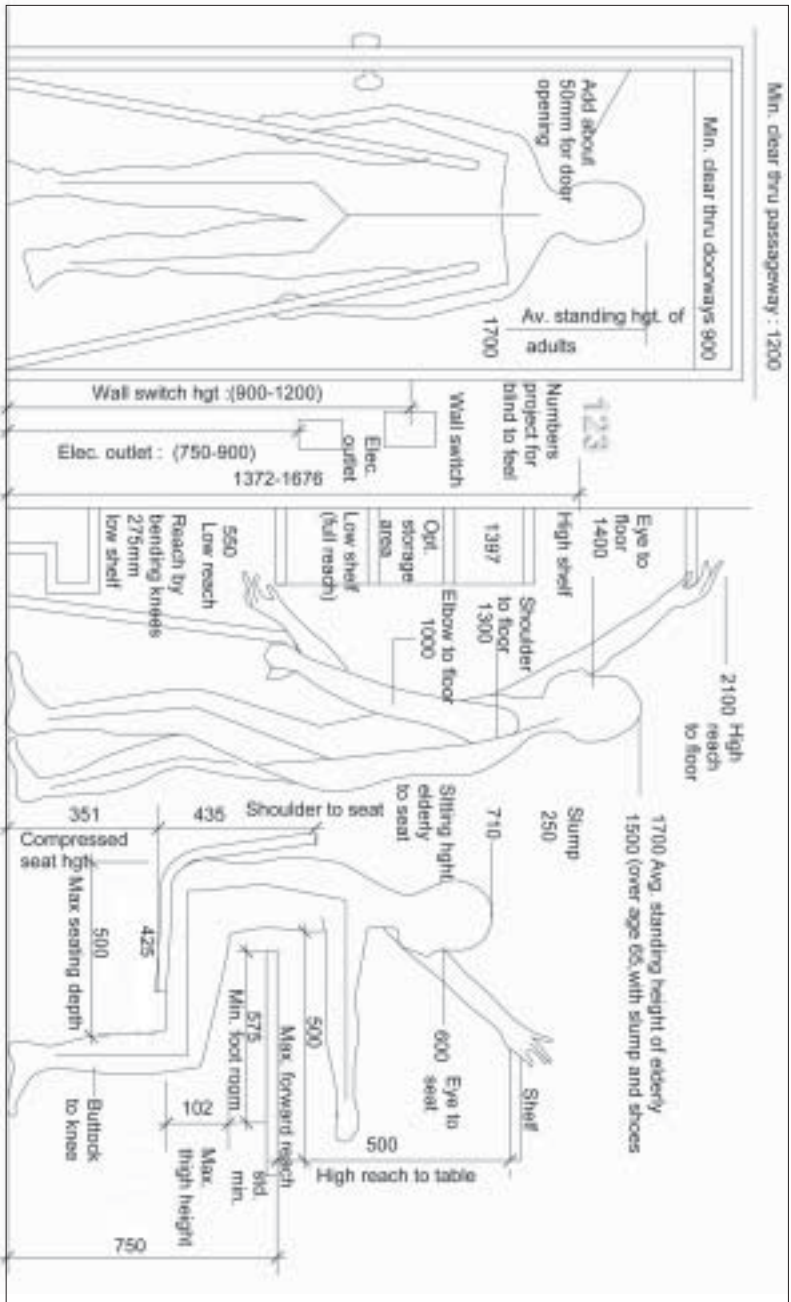

Fig. 26



04 - ACCESSIBLE ROUTES

-All areas of newly designed or newly constructed buildings and facilities (walks, halls, corridors, aisles, skywalks, tunnels, and other spaces) required to be accessible by general public shall be made barrier-free.

-Detectable warnings required shall comply with Section 4.3.5

4.1 - PHYSICAL PARAMETERS

4.1.1 - Location

-At least one accessible route complying with Section 3 shall be provided within the boundary of the site from public transportation stops, accessible parking spaces, passenger loading zones, and public streets or sidewalks to an accessible building entrance they serve.

-The accessible route shall, to the maximum extent feasible, coincide with the route for the general public.

-At least one accessible route shall connect accessible buildings or facility entrances with all accessible spaces and elements on the same site.

-At least one accessible route shall connect accessible buildings or facility entrances with all accessible dwelling units within the building or facility.

-An accessible route shall connect at least one accessible entrance of each accessible dwelling unit with those exterior and interior spaces and facilities that serve the accessible dwelling unit.

-Ground and floor surfaces along accessible routes should comply with the specifications in Section 3.2, have discernible colours and non slippery materials. Demarcation can be made

with textural differences too. Appropriate signage complying with Section 1 should be placed to indicate the position of this route.

4.1.2 - Width

-The minimum clear width of an accessible route shall be 900 mm, except at doors.
(Ref. Section 06).

-If a person in a wheelchair must make a turn around an obstruction, the minimum clear width of the accessible route shall be 1100 mm. as shown in fig. 27 or 900 mm as shown in fig.28.

4.1.3 - Passing Space

-If an accessible route has less than 1500 mm clear width, then passing spaces, at least 1500 x1500 mm, shall be located at intervals not to exceed 60 mts. A 'T-intersection' of two corridors or walks is an acceptable passing place.

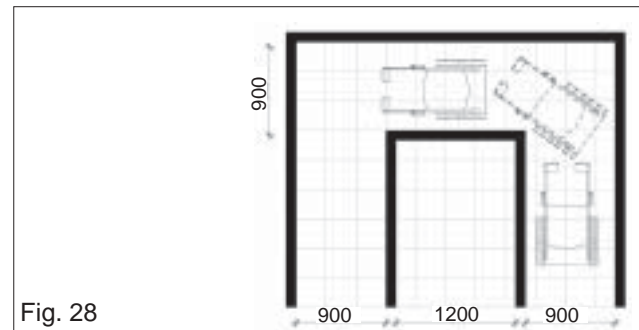
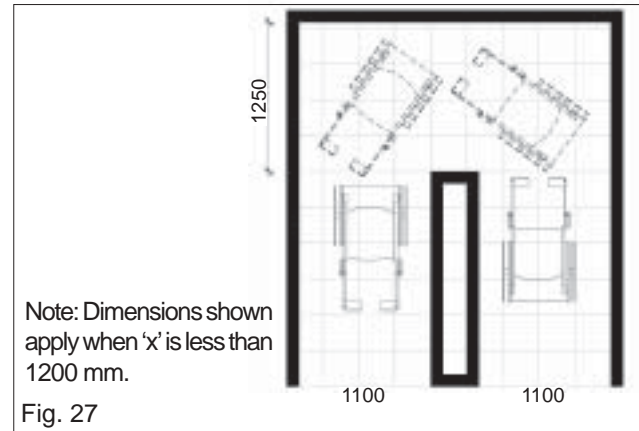

4.1.4 - Head Room

-Walks, halls, corridors, passageways, aisles, or other circulation spaces shall have 2000 mm minimum clear head room. (fig.29)

-If vertical clearance of an area adjoining an accessible route is reduced to less than 2000 mm, (nominal dimension), a barrier or signage to warn visually impaired persons shall be provided. (fig.30)

4.1.5 - Slope

-An accessible route with a running slope greater than 1:20 is a ramp and shall comply with Section 4.6

-Nowhere shall the cross slope of an accessible route exceed 1:50.

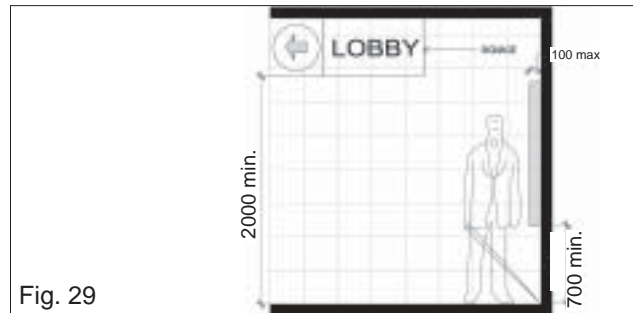

Fig. 29

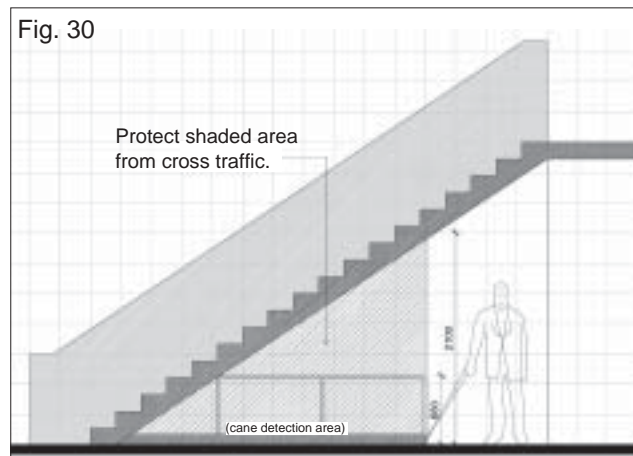

Fig. 30

4.1.6 - Changes in Levels

-If an accessible route has changes in level greater than 12 mm, then a curb ramp, ramp, elevator, or platform lift (as permitted in Section 3.1) shall be provided that complies with Sections 4.5, 4.6, 4.8 or 4.9 respectively.

-An accessible route does not include stairs, steps, or escalators.

4.1.7- Guiding Blocks

-Guiding blocks complying with Section 4.3.5 shall be provided at all crucial locations along the accessible route.

4.1.8 - Signage

-The universal standard colour contrast code of white and blue should be followed in all the

signages and all numeric as well as alphabetical information sources. All signages should follow Section 01 for specifications.

4.2 - PROTRUDING OBJECTS

-Objects projecting from walls (eg. telephones, signages, and other accessories) with their leading edges between 700 mm and 2000 mm above the finished floor shall protrude no more than 100 mm into walks, halls, corridors, passageways, or aisles. (fig.29) Object which can be sensed by the cane, mounted below 700mm, may project any amount.

-Free-standing objects mounted on posts or pylons may overhang 300 mm maximum from 700 mm to 2000 mm above the finished floor. This projection should be reflected at the floor level in the form of raised level or colour, textural difference so as to be detected by the white cane. (fig.14 and 29)

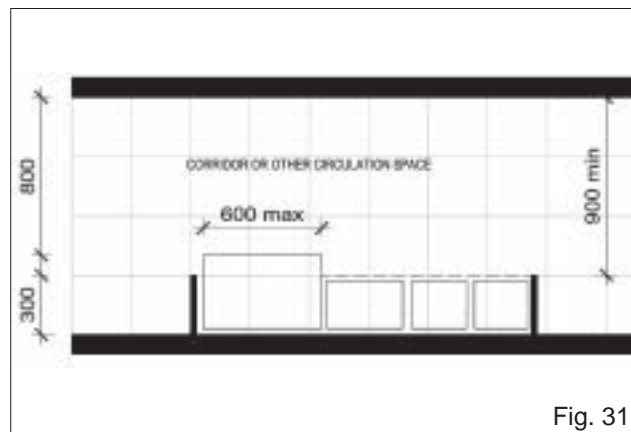

Fig. 31

-Protruding objects shall not reduce the clear width of an accessible route or manoeuvring space. If such protruding objects are to be placed inevitably, wing walls should be erected in accordance with details shown in Figure. 31.

4.3 - GROUND AND FLOOR SURFACES

4.3.1 - Surface Textures

-Ground and floor surfaces along accessible route and in accessible spaces, including floors, ramps, stairs and curb ramps, should be level, stable, firm and slip-resistant. The surface should not be excessively textured and undulating.

4.3.2 - Levels

-Changes in level up to 6mm. may be vertical and without edge treatment. (fig. 32(a))

-Changes in level between 6mm and 12 mm shall be bevelled with a slope, no greater than 1:2. (fig.32(b))

-Changes in level greater than 12 mm should be accomplished by means of a ramp complying with Section 4.6.

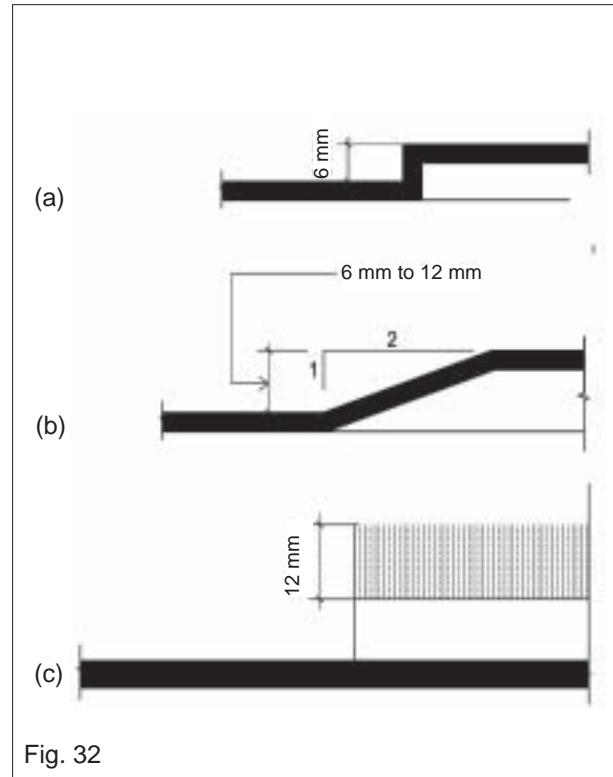

Fig. 32

4.3.3 - Carpets

-If carpets or carpet-tiles are used on a ground or floor surface, then it shall be securely attached: have a firm cushion, pad or backing and must leave a level loop, textured loop or level cut / uncut pile texture. (fig.32(c))

-The maximum pile thickness shall be 12 mm.

-The exposed edges of carpet shall be fastened to floor surfaces and should be trimmed along the entire length of the exposed edge.

4.3.4 Gratings

-If gratings are located in walking surfaces, then they shall have spaces no greater than 12 mm wide in one direction. (fig.33)

-If gratings have elongated openings, then they shall be placed so that the long dimension is perpendicular to the dominant direction of travel. (fig.34)

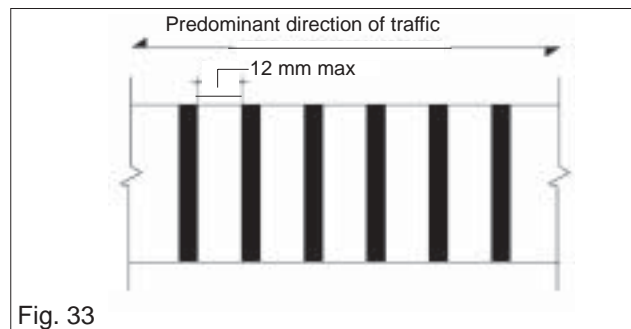

Fig. 33

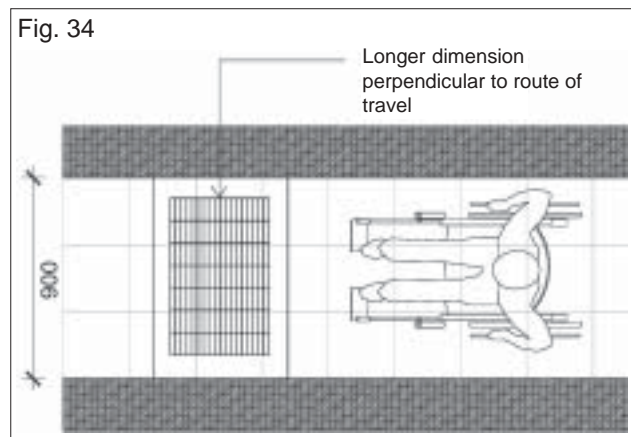

Fig. 34

4.3.5 - Guiding Blocks (Detectable Warnings)

4.3.5.1 - Walking Surfaces

-Detectable warnings shall consist of raised truncated domes with a diameter of nominal 24 mm, a height of nominal 5 mm and a centre-to-centre spacing of nominal 60 mm and shall contrast visually with adjoining surfaces, either light-on-dark or dark-on-light.

-The material used to provide contrast shall be an integral part of the walking surface.

-Detectable warnings used on interior surfaces shall differ from adjoining surfaces in resilience or sound-on-cane contact.

4.3.5.2 - Vehicular Areas

-If a walk crosses or adjoins a vehicular way, and the walking surfaces are not separated by curbs, railings or any other elements between the pedestrian areas and vehicular areas, the boundary between the areas shall be defined by a continuous detectable warning strip path which is 900 mm wide, with devices complying with Section 4.3.5.1

4.3.5.3 - Reflecting Pools

-The edges of reflecting pools must be protected by railings, walls, curbs or detectable warnings complying with Section 4.3.5.1

4.4 - VEHICULAR PARKING AND PASSENGER LOADING ZONES

4.4.1- Location

-Accessible parking spaces serving a particular building shall be located on the shortest accessible route of travel from adjacent parking to an accessible entrance.

-In parking facilities that do not serve a particular building, accessible parking shall be located on the shortest accessible route of travel to an accessible pedestrian entrance to the parking facility.

-In buildings with multiple accessible entrances with adjacent parking, accessible parking spaces shall be dispersed and located closest to the accessible entrances.

4.4.2 - Parking Spaces

-Accessible parking spaces shall be at least 2400 mm wide. Parking access aisles shall be part of an accessible route to the building or facility entrance. Two accessible parking spaces may share a common access aisle. (fig.35)

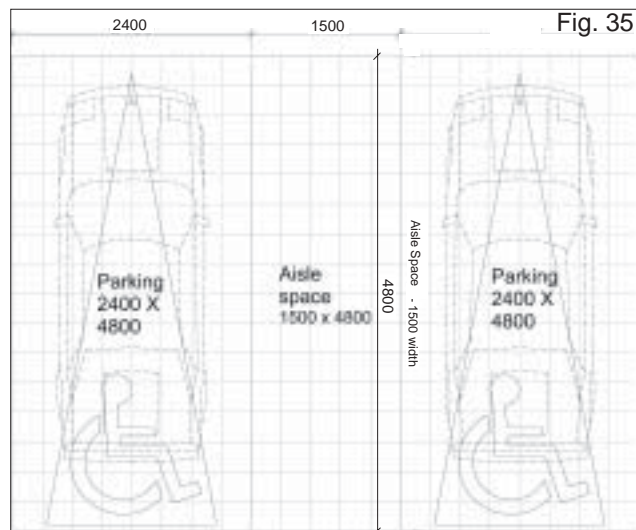

-Parked vehicle overhangs shall not reduce the clear width of an accessible route.

-Parking spaces and access aisles shall be level with surface slopes not exceeding 1:50 (2 per cent) in all directions.

4.4.3 - Passenger Loading Zones

-Passenger loading zones shall provide an access aisle at least 1500 mm wide and 4800 mm long adjacent and parallel to the vehicle pull-up space. (fig.36)

-If there are curbs between the access aisle and the vehicle pull-up space, then a curb ramp complying with Section 4.5 shall be provided.

-Vehicle standing spaces and access aisles shall be level with surface slopes not exceeding 1:50 (2 per cent) in all directions.

4.5 - CURB RAMPS

4.5.1 - Location

-Curb ramps complying with Sections 4.5.2 and 4.5.3 shall be provided wherever an accessible route crosses a curb. Detectable warnings required shall comply with Section 4.3.5

4.5.2 - Width

-The minimum width of a curb ramp shall be 900 mm, exclusive of flared sides.

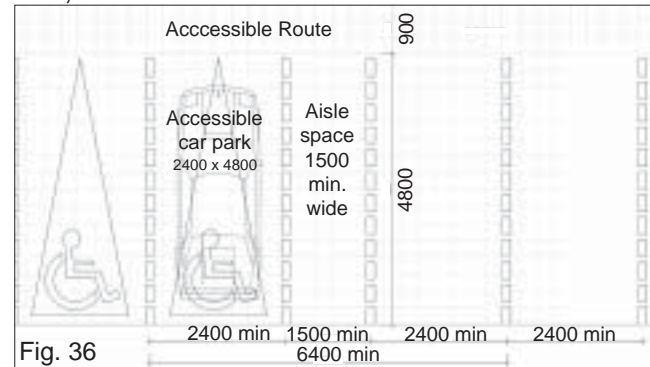

Fig. 36

4.5.3 - Slope

-Slopes of curb ramps shall comply with Section 4.6.2. The slope shall be not more than 1:10 and the width not less than 900 mm. Transitions from ramps to walks, gutters, or streets shall be flush and free of abrupt changes. Maximum slopes of adjoining gutters, road surface immediately adjacent to the curb ramp, or accessible route shall not exceed 1:12. (fig.37)

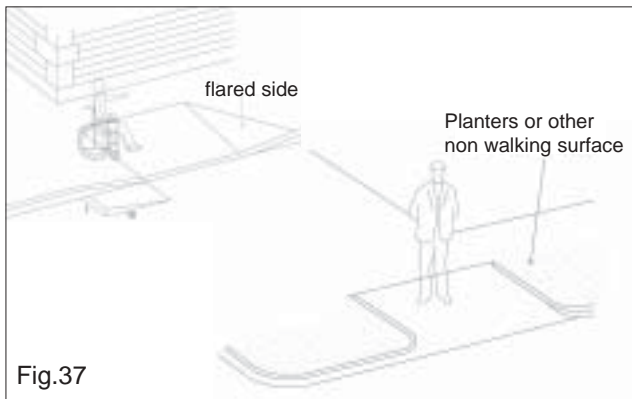

Fig.37

4.6 - RAMPS

-Any part of an accessible route with a slope greater than 1:20 shall be considered a ramp and shall comply with the table below:

Maximum slope	Maximum length	Maximum rise
1:20 i.e., 9%	--	--
1:16 i.e., 6%	8 mts.	0.50 mts.
1:14 i.e., 7%	5 mts.	0.35 mts.
1:12 i.e., 8%	2 mts.	0.15 mts.
1:10 i.e., 10%	1.25 mts.	0.12 mts.
1:08 i.e., 12%	0.5 mts.	0.06 mts.

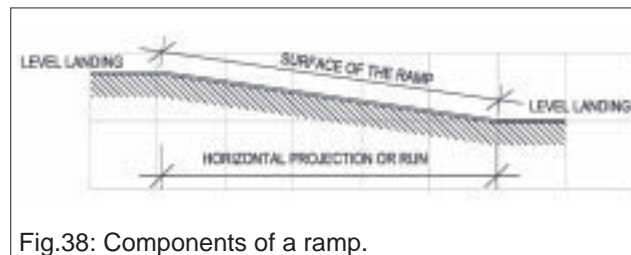

Fig.38: Components of a ramp.

4.6.1 - Slope and Rise

-The least possible slope shall be used for any ramp. The maximum slope of a ramp in a new construction shall be 1:12. The maximum rise for any run shall be 760 mm. (fig.38)

Curb ramps and ramps to be constructed on existing sites or in existing buildings or facilities may have slopes and rises as allowed in the table on page 37 if space limitations prohibit the use of a 1:12 slope or less.

4.6.2 - Landings

-Ramps shall have level landings at bottom and top of each ramp and each ramp run, and at every 10 mts of run.(fig. 38)

-The landing shall be at least as wide as the ramp run leading to it. The landing length shall be a minimum of 1500 mm clear.

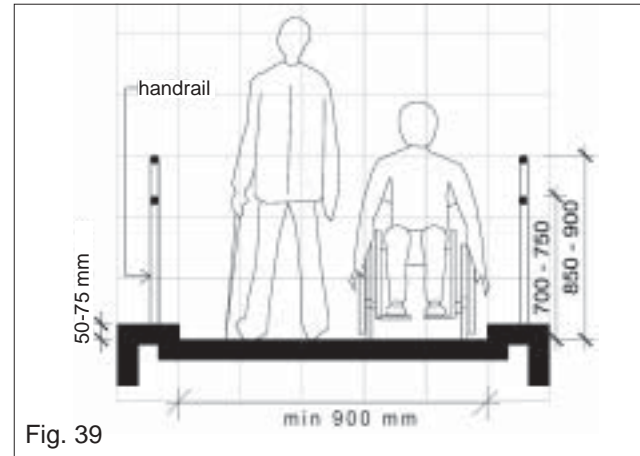

Fig. 39

-If ramps change direction at landings, the minimum landing size shall be 1500 mm x 1500 mm.

4.6.3 - Clear Width

-The minimum clear width of a ramp shall be 900 mm.(fig.39)

4.6.4 -Handrails

-If a ramp run has a rise greater than 150 mm or a horizontal projection greater than 1800 mm, then it shall have handrails on both sides. Handrails are not required on curb ramps or adjacent to seating in assembly areas. Handrails shall comply with Section 4.10 and shall have the following features:

-Handrails shall be provided along both sides of ramp segments. The inside handrail on switchback or dog-leg ramps shall always be continuous.

-If handrails are not continuous, they shall extend at least 300 mm beyond the top and bottom of the ramp segment and shall be parallel with the floor or ground surface. (fig. 40)

-Gripping surfaces shall be continuous. The top of handrail gripping surfaces shall be mounted between 800 mm and 900 mm above ramp surfaces.

4.7 - STAIRS

4.7.1 - Treads and Risers

-On any given flight of stairs, all steps shall have uniform riser heights and uniform tread widths.

-Stair treads shall be no less than 280 mm wide, measured from riser to riser. (fig.41)

- Open risers are not permitted on an accessible stair.

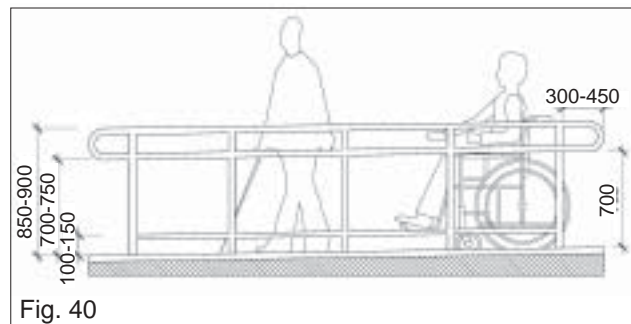

4.7.2 - Nosing

-Nosing should be avoided, but if it is inevitable, it should follow the following specifications:

-The undersides of the nosing shall not be abrupt. The radius of curvature at the leading edge of the tread shall be no greater than 13 mm.

-Risers shall be sloped or the underside of the nosing shall have an angle not less than 60 degrees from the horizontal. Nosing shall project no more than 40 mm. (fig.41)

4.7.3 - Handrails

-Handrails required by staircase shall comply with Section 4.10. (fig.42)

4.8 - ELEVATORS

4.8.1 - General

-Accessible elevators shall be on an accessible route and shall comply with Section 4.10 and with the ASME A17.1-1990, Safety Code for Elevators and Escalators. (fig.44)

-Freight elevators shall not be considered as meeting the requirements of this Section unless the only elevators provided are used as combination passenger and freight elevators for the public and employees.

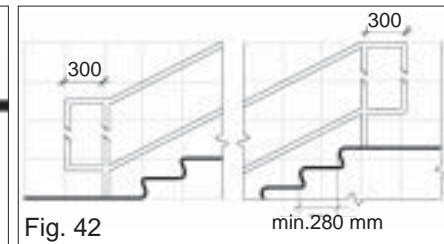
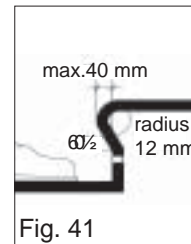

4.8.2 - Automatic Operation

-Elevator operation shall be automatic. Each car shall be equipped with a self-levelling feature that will automatically bring the car to floor landings within a tolerance of 13 mm under rated loading to zero loading conditions.

-This self-levelling feature shall be automatic and independent of the operating device, and shall correct the over travel or under travel.

4.8.3 - Hall Call Buttons

-Call buttons in elevator lobbies and halls shall be centred between 900 mm and 1200 mm above the finished floor level.

-Such call buttons shall have visual/audio signals to indicate when each call is registered and when each call is answered. Call buttons shall be a minimum of 20 mm in the smallest dimension.

-The button designating the up direction shall be on top. (fig. 43, 45)

Note: The automatic door reopening device is activated if an object passes through either line 'A' or line 'B'. Line 'A' and 'B' represent the vertical locations of the door reopening device not requiring contact.

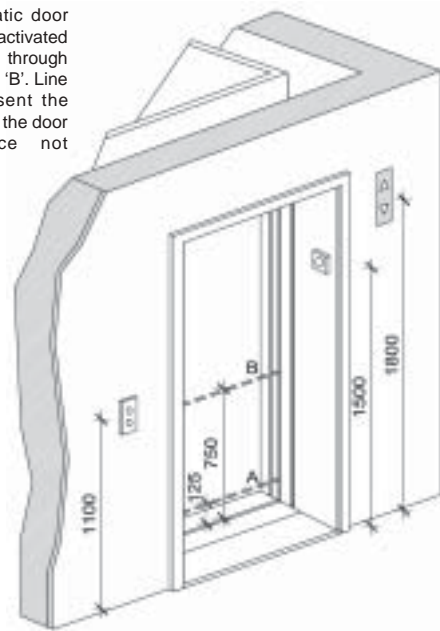

Fig. 43

-Buttons shall be either raised or flush and never be indented into the console panel.

-Objects mounted beneath hall call buttons shall not project into the elevator lobby more than 100 mm.

4.8.4 - Car Controls

Elevator control panels shall have the following features:

-All control buttons shall be at least 20 mm in their smallest dimension. They shall be raised or flush.

-All control buttons shall be designated by Braille and by raised standard alphabet characters for letters, Arabic characters for numerals, or standard symbols. Raised and Braille characters and symbols shall comply with Section 01.

-The call button for the main entry floor shall be designated by a raised star at the left of the floor designation. (fig.46)

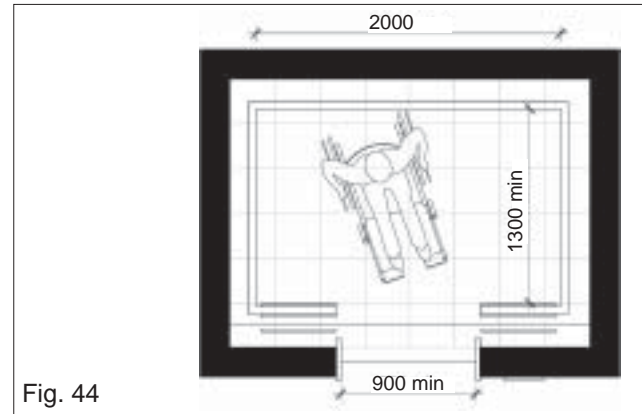

Fig. 44

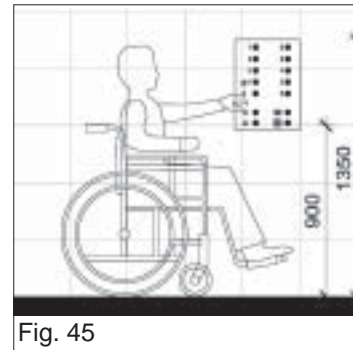

Fig. 45

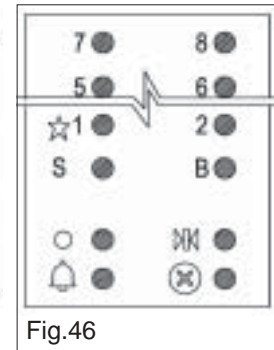

Fig.46

-All raised designations for control buttons shall be placed immediately to the left of the button to which they apply. Applied plates, permanently attached, are an acceptable means to provide raised control designations.(fig.47 and 48)

-Floor buttons shall be provided with visual indicators which switch on when each call is registered and switch off when each call is answered.

-All floor buttons shall be no higher than 1200 mm above the finished floor level for side approach and 1200 mm for front approach.

-Emergency controls, including the emergency alarm and emergency stop, shall be grouped at the bottom of the panel and shall have their centrelines no less than 900 mm above the finished floor level. (fig.45, 46)

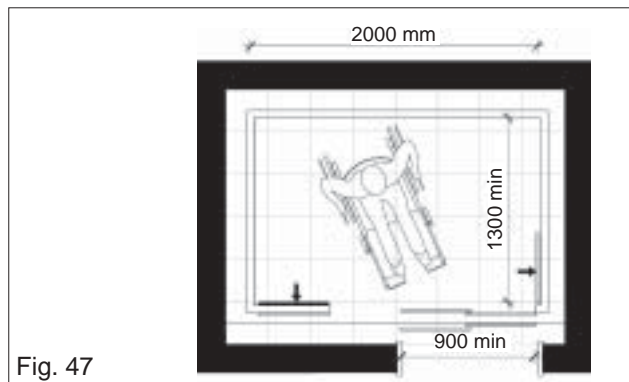

Fig. 47

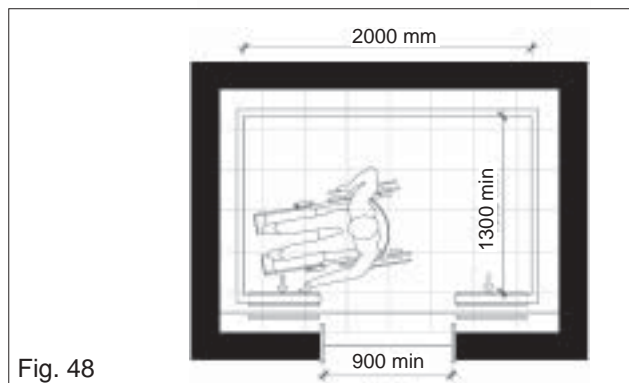

Fig. 48

4.8.5 - Audio & Visual Signals

- A visible and audible signal shall be provided at each hoist-way entrance to indicate which car is answering a call. Audible signals can sound once for the up direction and twice for the down direction or shall have verbal enunciators that say “UP” or “DOWN”.

Visible signals shall have the following features:

- 1. Hall lantern fixtures shall be mounted so that their centreline is at least 1800 mm above the lobby floor. (fig.43)
- 2. Visual elements shall be at least 65 mm in the smallest dimension.
- 3. Signals shall be visible from the vicinity of the hall call button. (fig.43) In-car lanterns located in cars, visible from the vicinity of hall call buttons, and conforming to the above requirements, shall be acceptable.

4.8.6 - Raised and Braille Characters on the Hoist-way Entrances

- All hoist-way entrances shall have raised and Braille floor designations provided on both jambs. The centreline of the characters shall be 1500 mm above the finished floor level. Such characters shall be 50 mm high and shall comply with Section 01. (fig. 43)

4.8.7 - Door Delay for Car Calls

- The minimum time for elevator doors to remain fully open in response to a car call shall be 3 seconds.

4.8.8 - Specifications for Car Dimensions

- The floor area of elevator cars shall provide space for wheelchair users to enter the car, manoeuvre within reach of controls, and exit from

the car. Acceptable door opening for the car is 900 mm. minimum. Inner dimensions shall be 1300 mm x 2000 mm. minimum clear. (fig.44)

- The clearance between the car platform sill and the edge of any hoist-way landing shall be no greater than 30 mm.

4.8.9 - Floor and Wall Specifications for the Car

- Floor surfaces shall comply with Section 4.3. A mirror should be placed on back wall of the lift car, for additional visibility for the wheelchair users while backing out of the car.

4.8.10 - Illumination Levels

- The level of illumination at the car controls, platform, car threshold and landing sill shall be at least 53.8 lux (5 foot-candles).

4.9 - PLATFORM LIFTS (WHEELCHAIR LIFTS)

- A platform lift (wheelchair lift) should be provided at locations of vertical circulation on an accessible route where it is impracticable to provide a lift or a ramp. (fig.52)

4.9.1 - Lift Size

-The minimum width of the platform lift should be 900 mm. and minimum length should be 1200 mm.(fig. 50 and 51)

4.9.2 - Vertical Movement Platform Lifts

- For maximum level change of 2500 mm. vertical movement platform lifts can be installed. (fig.49a)

- For level changes of more than 2500 mm., the lift should be placed in a closed structure with doors at different accessible levels. (fig.49.b)

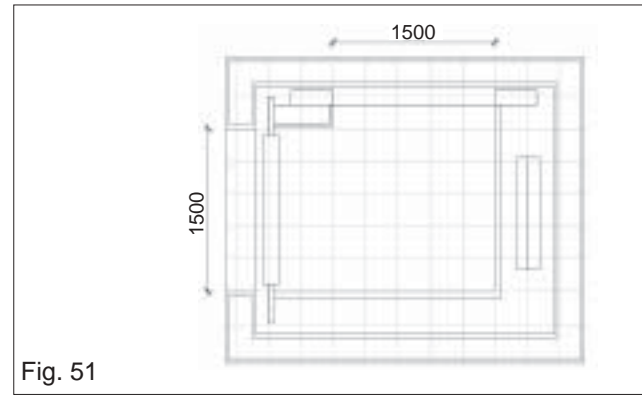
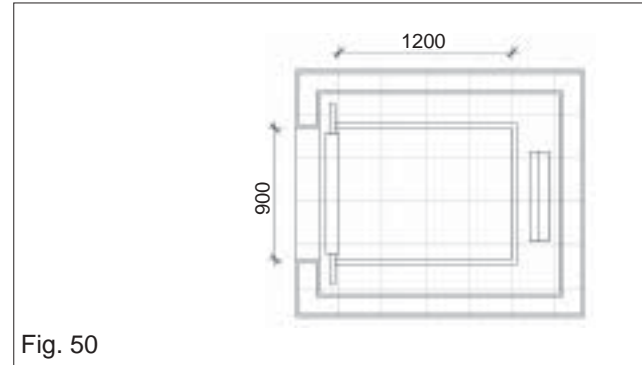
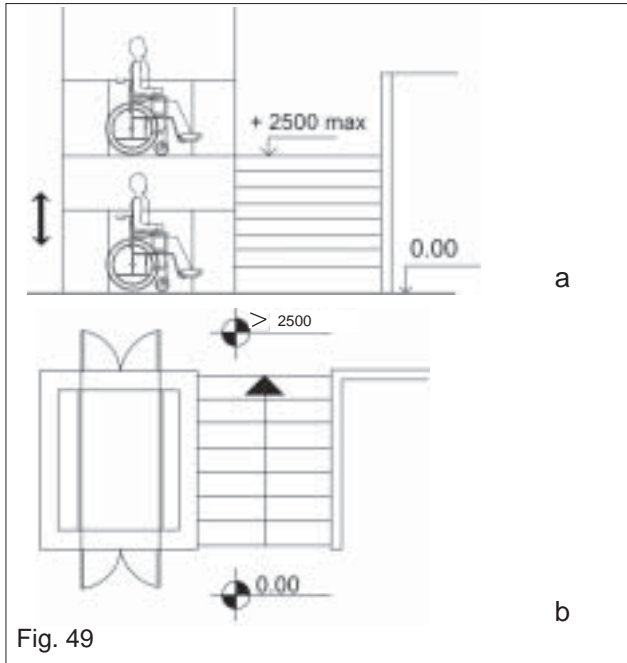

4.9.3 - Inclined Movement Platform Lifts

- It consists of three elements: a railing, an electric generator and a moving platform or a seat.(fig.52)
- The operating system of the lift can be lateral or suspended as per the available space and shape of staircase.(fig.53)
- This type of lift can be installed along the stair wall leaving 900 mm. clear width of the staircase.

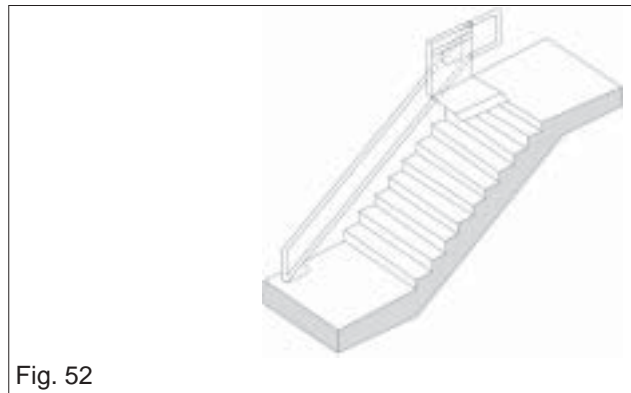

Fig. 52

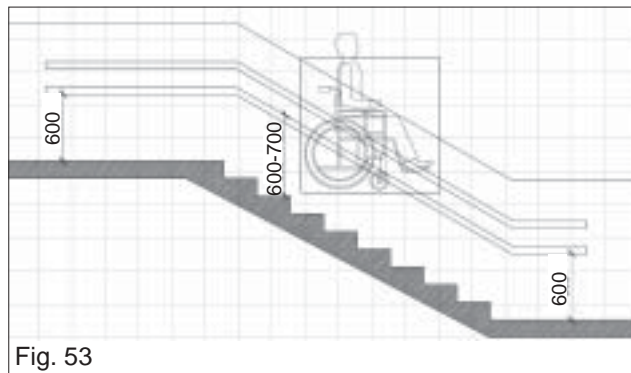
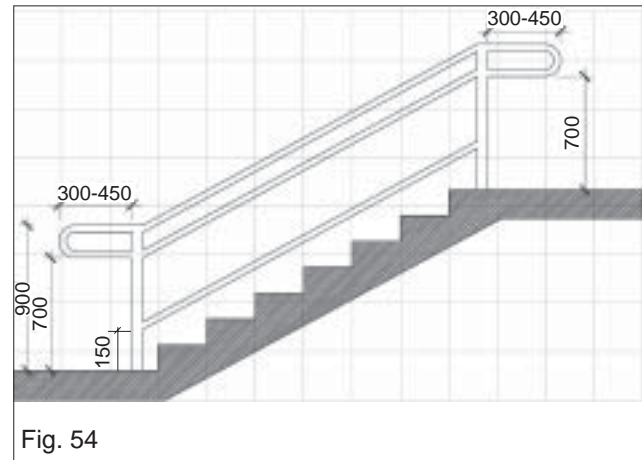

Fig. 53

4.10 - HANDRAIL REQUIREMENTS

4.10.1 - Handrail Form

- Should be provided with rounded forms for better grip.
- Handrails shall not rotate within their fittings.
- Should have a cross section between 30 and 40mm diameter. (fig.55, 56)
- Should be continuous, even at landings, without any break, interruption or obstructions. The ends should be bent and made to blend into the wall or extend to the floor and not end abruptly.
- It should be able to resist a force of at least 1.3 kN applied vertically or horizontally.



4.10.2 - Handrail Placement

- The railing must be installed at 800 to 900 mm height from the stair nosing. A second rail could be mounted at 700 mm to 750 mm and a third at 100mm to 150mm from the finished floor level of the ramp. (fig.54)

- It should be placed on both sides of stairs, ramps and raised platforms more than 400 mm height.(fig.39, 40, 54)

- Should be extended at least 300 mm beyond the last step or end of the ramp on either side.(fig.40, 54)

- The railing, if wall mounted, should have a clear space of minimum 40 mm from the wall. (fig.55,56)

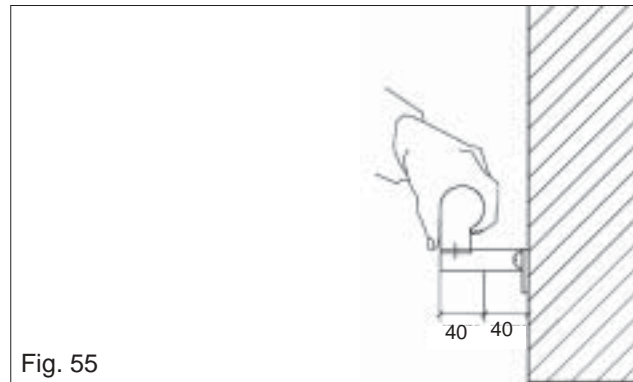

Fig. 55

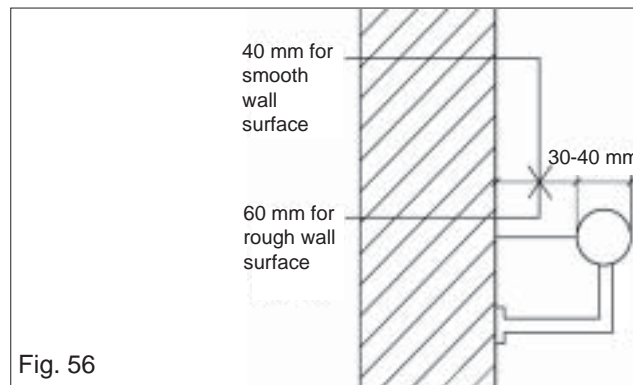

Fig. 56

- A recess /niche containing the railing must extend at least 150 mm above the top of the rail.(fig.57)

4.10.3 - Handrail Texture

- Should be slip-resistant

- Railings should be treated in a contrasting colour to the surroundings for the visually impaired.

- For emergency stairs or ramps a tactile strip at least 900 mm long should be applied to the top and bottom ends of the handrail to alert the visually impaired.

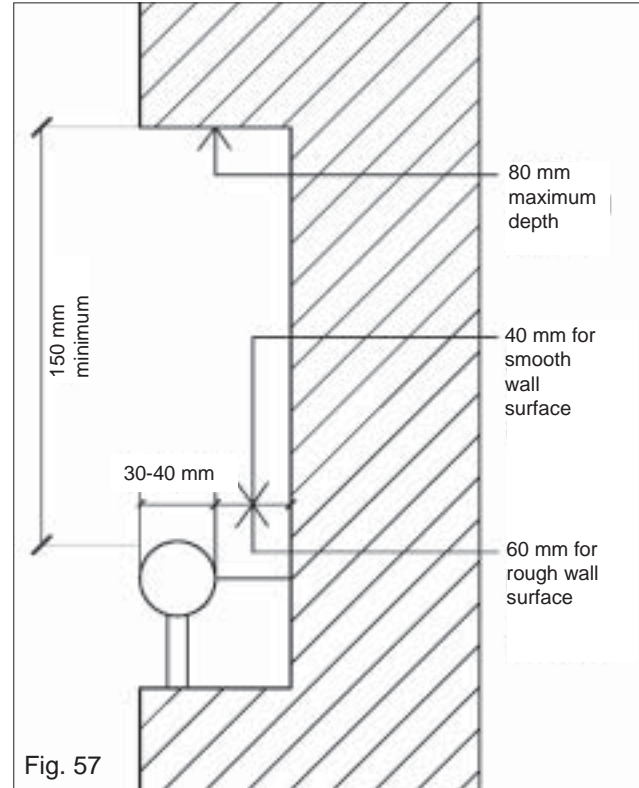

05- ENTRANCES

5.1- MANDATORY

- At least one entrance in the facility should have accessibility to the disabled person. In the case of a new construction, this entrance should be the main entrance. The position of this entrance and alternate routes should be well marked through proper accessibility signages using the international symbol of accessibility.

- The entrance landing should have a minimum dimension of 1800 mm x 2000 mm. The flooring of this landing should be made conspicuously distinct, with tactile rendering, from the surroundings to guide the visually impaired.

- This entrance should be well connected by accessible pathways to other accessible

amenities such as parking spaces, both indoor and outdoor, local transit bus-stops and drop-off areas.

- In the case of multi-storied buildings, this entrance should be connected to an accessible elevator or ramp.

5.2 - SUGGESTIVE

- A public telephone and benches for waiting may be installed in the entrance space. This is mandatory if the accessible entrances require assistance. In such cases the phones must provide direct communication with informed personnel who can provide assistance.

- The entrance landing should have proper cover for protection against adverse weather conditions.

06 - DOORS

6.1 - DOOR CLEARANCE

- Any type of door, hinged, folded or sliding should have a minimum clear opening of 900 mm when fully open, excluding the frame or any other such projections.(fig.58)

- Revolving doors and turnstiles should be supplemented with auxiliary side hung door not less than 900 mm clear.(fig.60,61, 66)

- Two-way swing doors must have a clear vision panel placed between 1000 to 1500 mm from the finished floor level to give visibility to the other side. (fig.62)

- In the case of double-leaf doors, at least one door should have a minimum opening clearance of 900 mm. (fig.63)

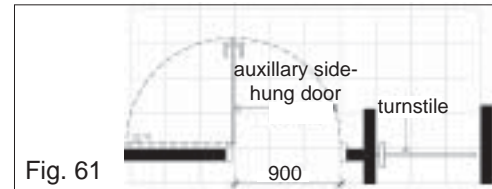
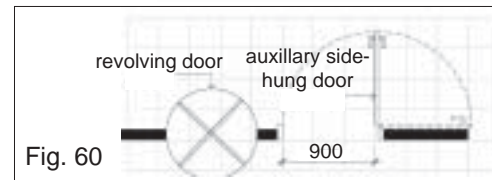
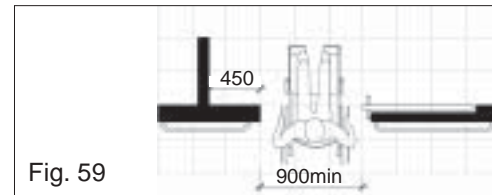
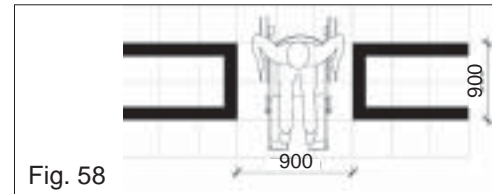

- Thresholds, if unavoidable, should not exceed 12 mm and should have a bevelled sloped edge at 1:12 gradient. (ref. fig.32)

- Clear floor space of 1500 mm x 1500 mm to be provided on the pull side and 1200 mm x 1200 mm on the push side. (fig.64)

- Minimum movement space should be provided towards the latch side not less than 600 mm on the pull side and 300 mm on the push side for easy access of wheelchairs. For two-way swing doors, a minimum of 300 mm to be provided on both sides. (fig.64)

- In the case of a vestibule, a minimum space of 1200 mm should be provided over and above the width of the preceding door between the two doors in series. (fig.64)

- The exit landing should not be lower than 12 mm from the finished floor level of the preceding space.

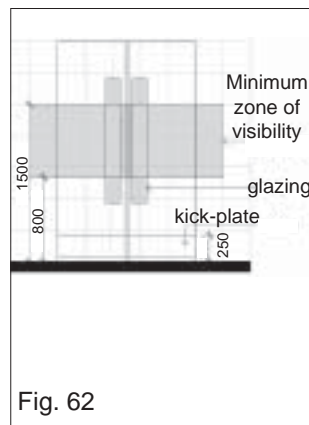

Fig. 62

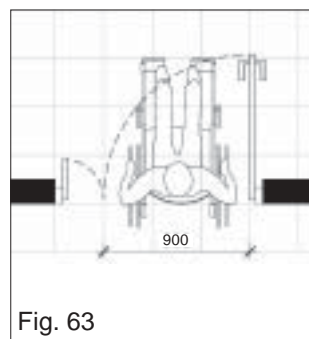

Fig. 63

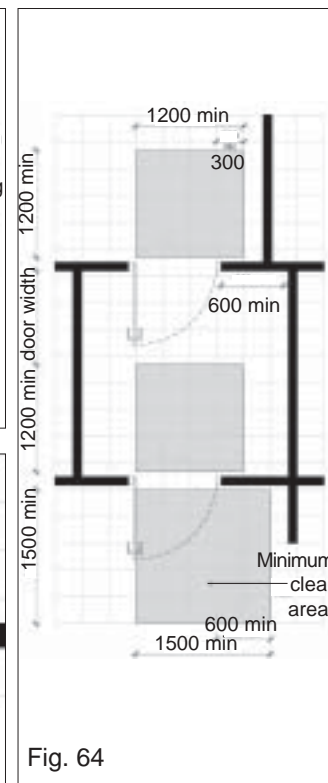

Fig. 64

6.2 - DOOR HARDWARE

- Hardware should be selected such as not to require fine finger control, grasping. Handle should be of a lever type rather than circular knob or latches. (fig.65)

- Door hardware such as handles, latches, etc. should be mounted between 900 mm and 1200 mm from the finished floor level and must enable the user to operate it by a single hand. (fig.67, 68)

- Maximum force for pushing or pulling a door should be 38 N for exterior hinged doors and 22 N for interior hinged, sliding or folding doors, excluding the force required to retract the locking device and differential pressures in the case of external doors.

- The above two standards apply to emergency pushbars or panic bars also.

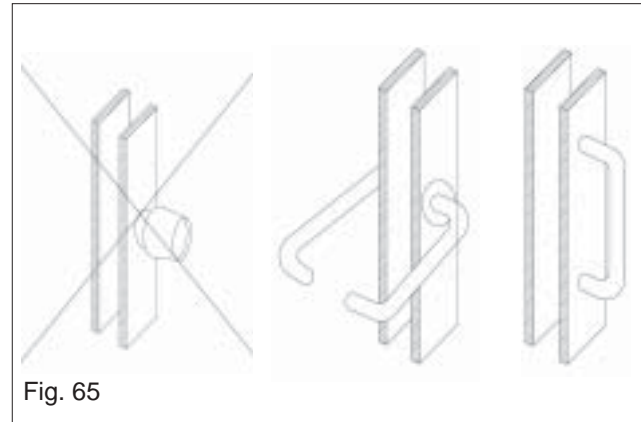

Fig. 65

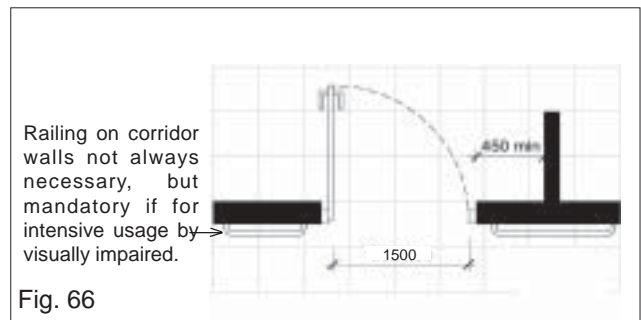
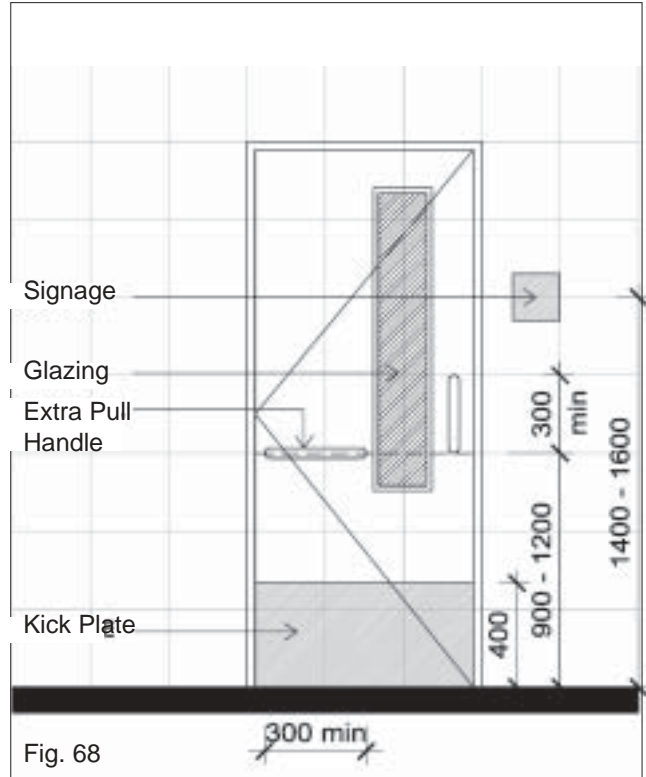
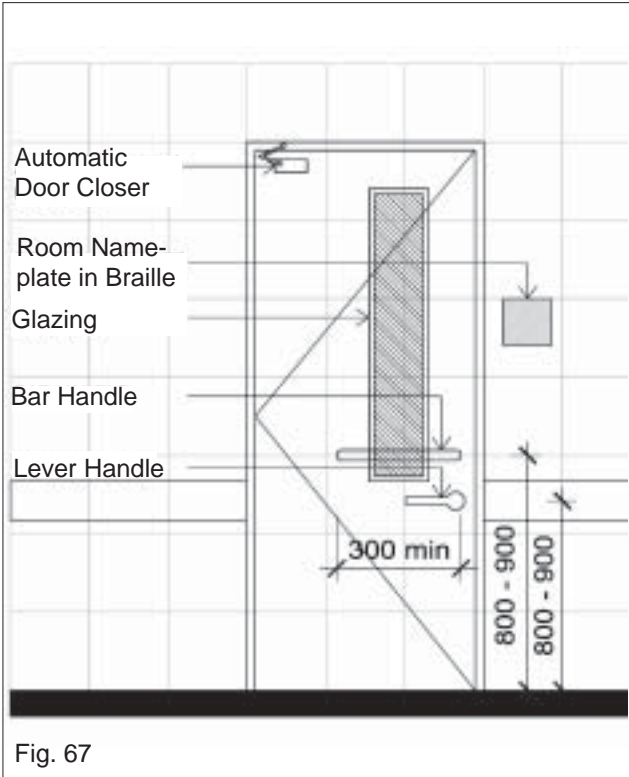
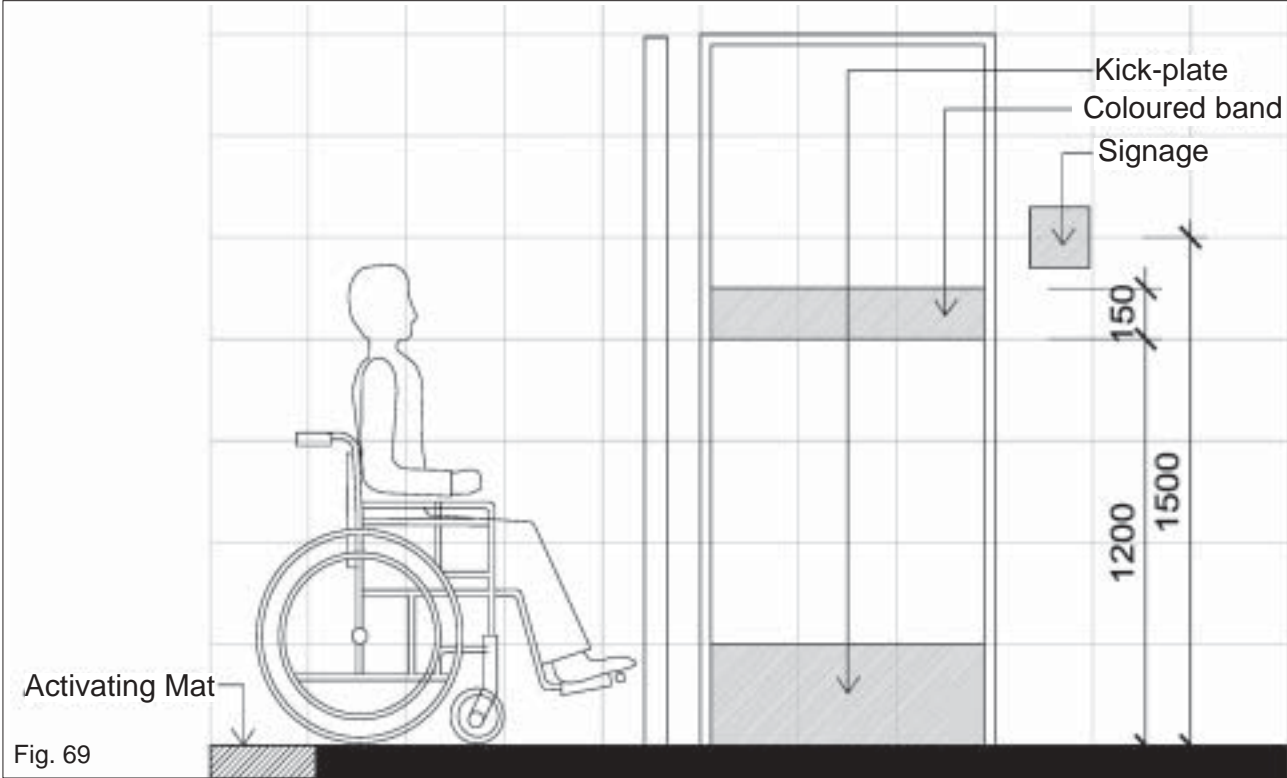

Fig. 66





Activating Mat

Fig. 69

Kick-plate
Coloured band
Signage

150

1200

1500

- The sweep period should be adjusted such that from an open position of 90 degrees to a semi-closed position of 12 degrees, it takes not less than 3 seconds.

- Push button gadgets for operating the mechanised doors should be located between 900 mm and 1200 mm height from the finished floor level. Activation mats are preferred also as a locational cue. (fig.69)

6.3 -SUGGESTIVE

- High-use doors should be provided with at least 250mm high kick-plates to protect the doors.(fig.68)

- A weather stripping is preferable to the threshold.

- If possible, automatic doors, swing or sliding, to be preferred to manually operated doors.

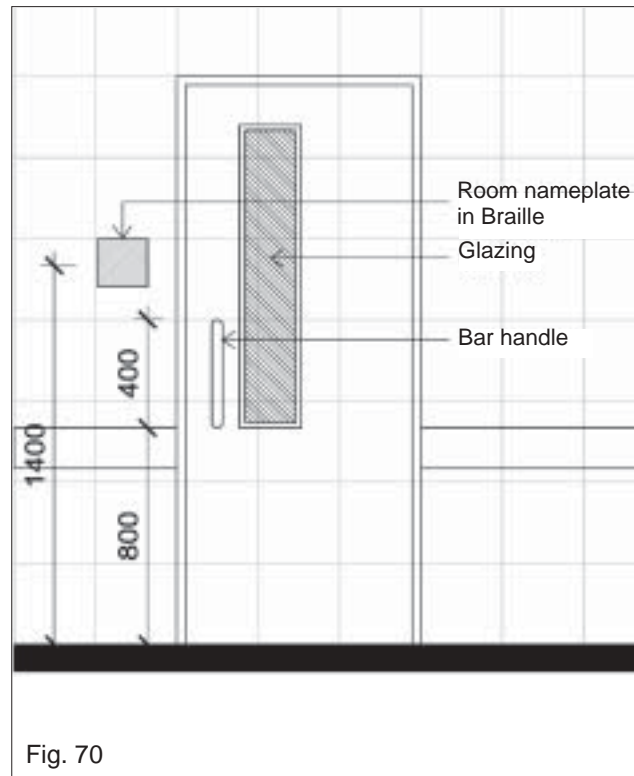

- Completely glazed doors should be avoided in buildings frequented by people with visual impairments. If at all they are installed then proper protection bars and coloured bands should be placed at respective heights.

- An extra pull handle, approximately 300mm in length should be located 200 to 300mm from the side of the door with the hinges, mounted between 900 mm and 1200 mm from the finished floor level to facilitate closing the spring mounted doors locked at 90½.(fig.67, 68)

- Colour and brightness contrast markings no less than 130 mm in width should be applied horizontally at a height between 1200 and 1600 mm above the floor. (fig.70)

- The door and the frame may be painted in a contrasting colour scheme to the adjoining walls and the glass itself maybe rendered to facilitate identification.

07 - WINDOWS

- Operating systems for the auxiliary hardware such as blinds, etc. and the locking devices for the shutters should be fixed between 900mm and 1200mm from the finished floor level for operation by the invalid . (fig.71)

- Any opening or glazing below the height of 900 mm from the finished floor should be non-opening.

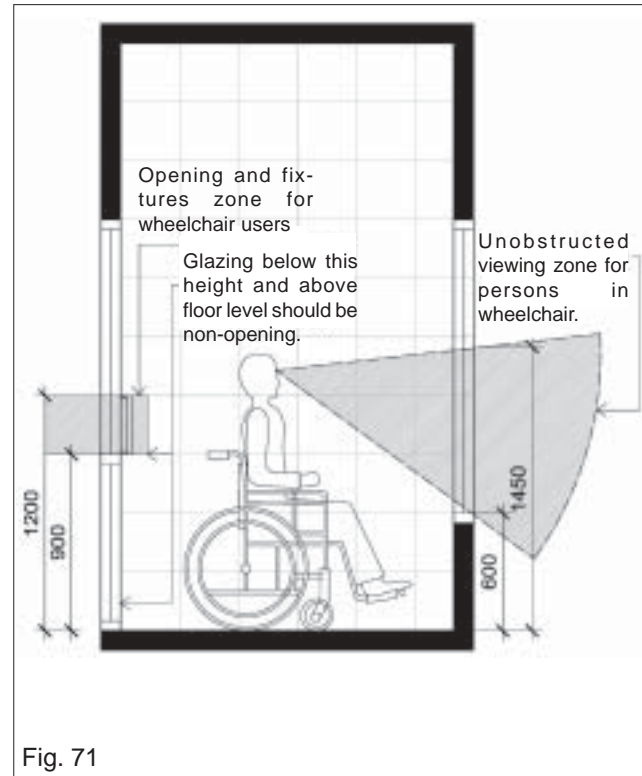

Fig. 71

08 - WASH / BATHROOM AND SHOWER AREA

- The washroom should have a minimum internal dimension of 1750 mm x 1500 mm. (fig.72, 75)
- Controls must be mounted between 900 mm and 1200 mm from the finished floor level.(fig73)
- Bathing space should have minimum dimensions of 1500 mm x 750 mm for usage by all types of disabled. (fig.72, 74,75)
- Should provide 900mm horizontal grab bar and 750mm vertical grab support at 900 mm from the finished floor level. (fig.73,74, 77)
- A shower head for the cubicle should be of the hand-held type with allocation for fixed use. The hose must be not less than 1500 mm long. (fig.73, 74)

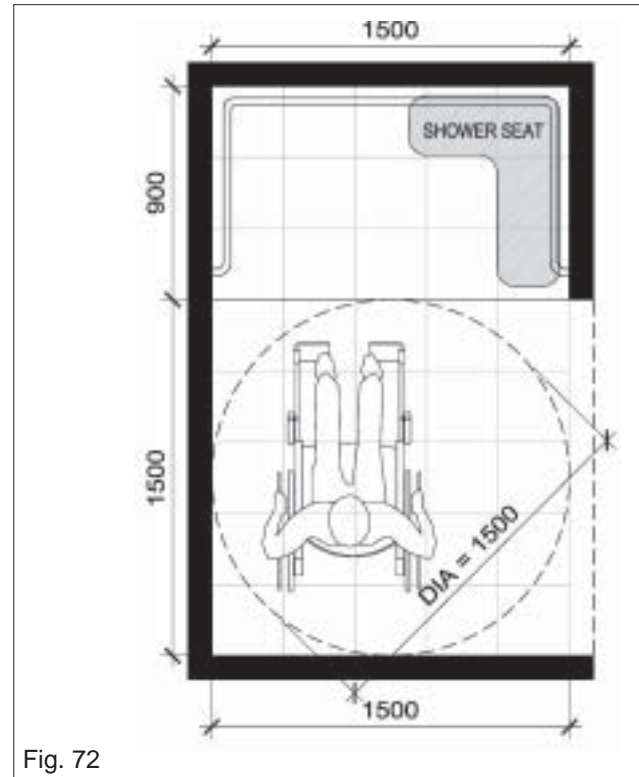
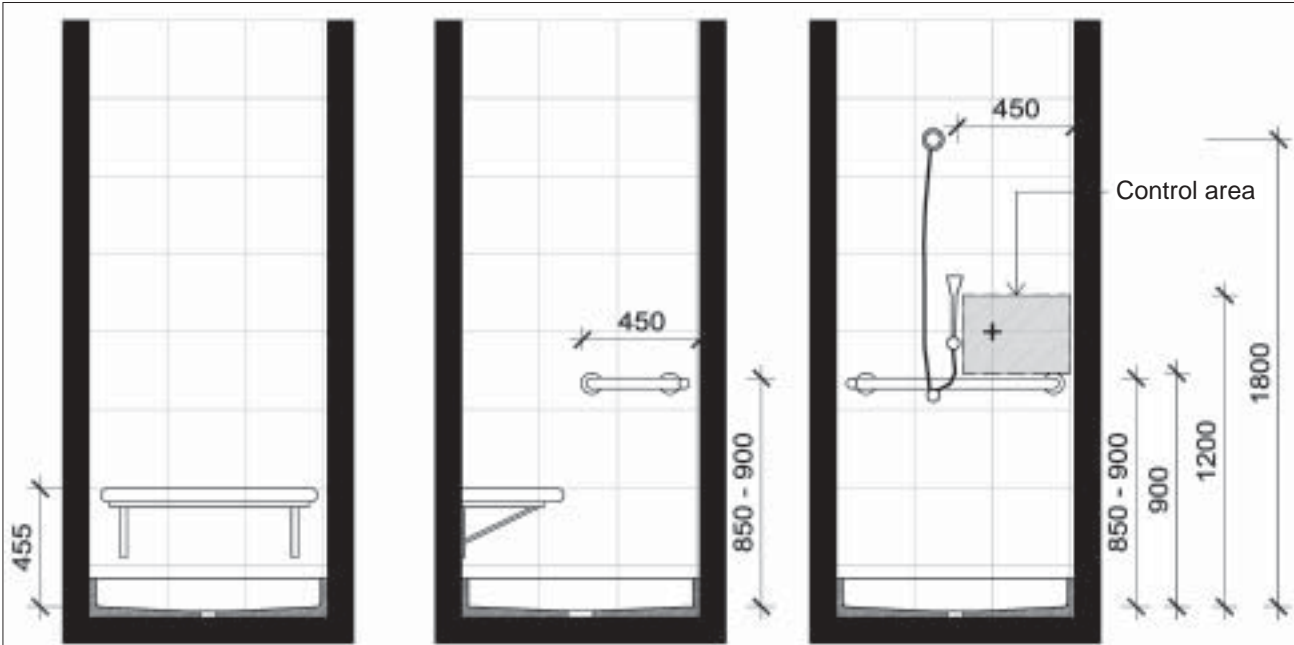

Fig. 72



Seat wall

Back wall

Control wall

Fig. 73

Fig. 74

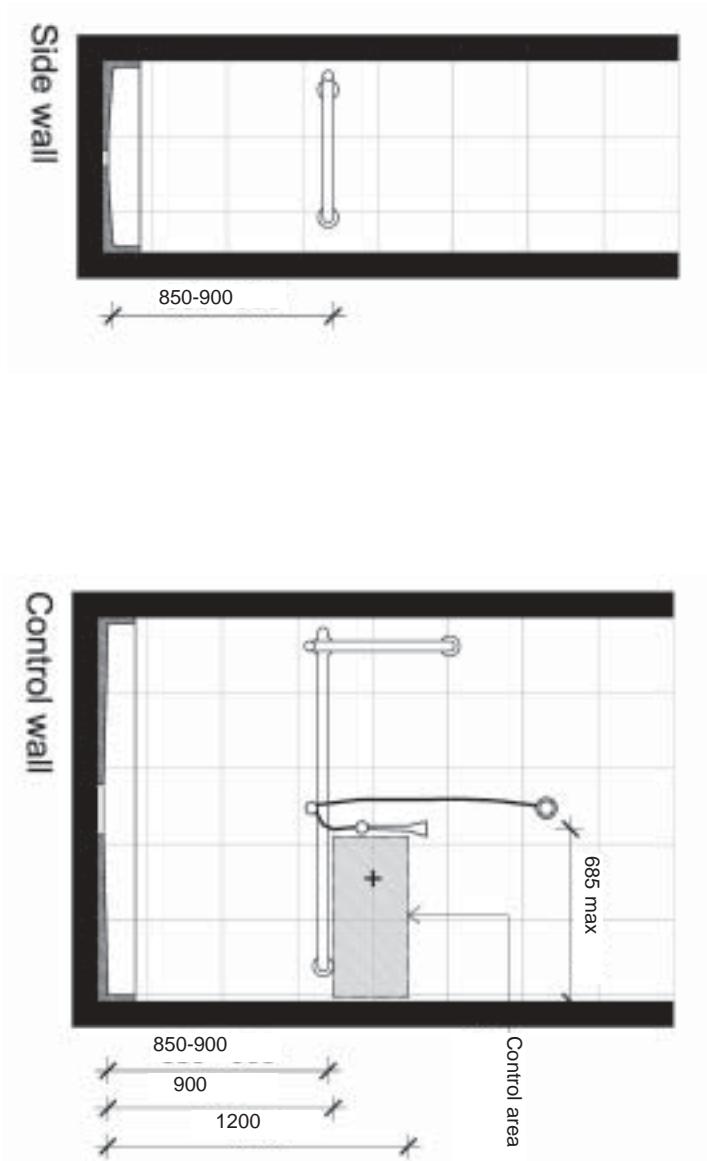

- Enclosures made for the shower area and bathtubs should not interfere with the controls and must allow easy transfer space for the person on the wheelchair. (fig.72, 75)

- Soap dishes must be recessed and placed on the same wall as the shower head at a height between 900 mm and 1200 mm from the finished floor level.

SUGGESTIVE

- If a seat is provided in the cubicle then it must be self- draining and be placed on the wall nearest to the controls with a minimum dimension of 300 mm extending the full width of the cubicle except the space required by the shower curtain. It must have its top at 500 mm from the finished floor level.(fig.75)

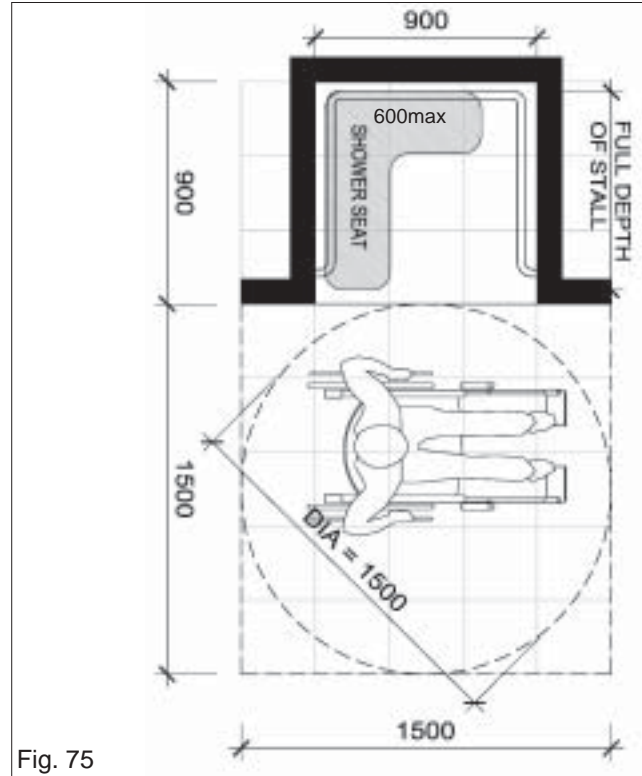

Fig. 75

8.1 - TOILET CUBICLES

- A minimum number of toilets for the disabled must be provided according to the user ratio. These must be equipped with the western water closet as opposed to the Indian-style pan.

- A toilet cubicle designed for a wheelchair user should be of internal dimensions not less than 1500 mm x 1500 mm. (fig.76) with a clear space not less than 900 mm wide next to the water closet.(fig.80, 81, 82)

8.2 - WATER CLOSET

- It must be equipped with grab-bars and tap/ toilet roll dispenser mounted below it at not more than 300 mm from the front edge of the seat and at a height between 50 mm and 250 mm from the top of the water closet seat. There should also be the provision of a clothes hook not more than 1300 mm from the finished floor level and

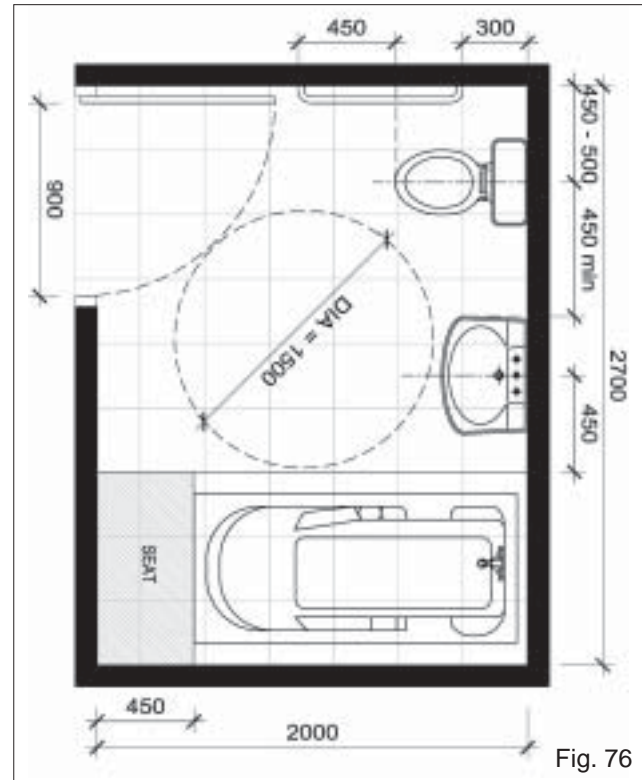

Fig. 76

projecting not more than 40 mm from the wall. (fig.77)

- The top edge of the toilet seat should be 500 mm from the finished floor level. (fig.77)

- It must have back support in absence of seat lid or tank. (fig.77)

- It must be preferably of the wall hung or corbel type. (fig.77)

- Grab-bars, mounted at a height between 280 mm and 300 mm from the top surface of the W.C. must be able to resist a load of not less than 1.3 kN applied vertically or horizontally. (fig.77)

- Must have a lever-type flush control fixed towards the wheel chair transfer side to facilitate flushing after transfer.

Fig. 77

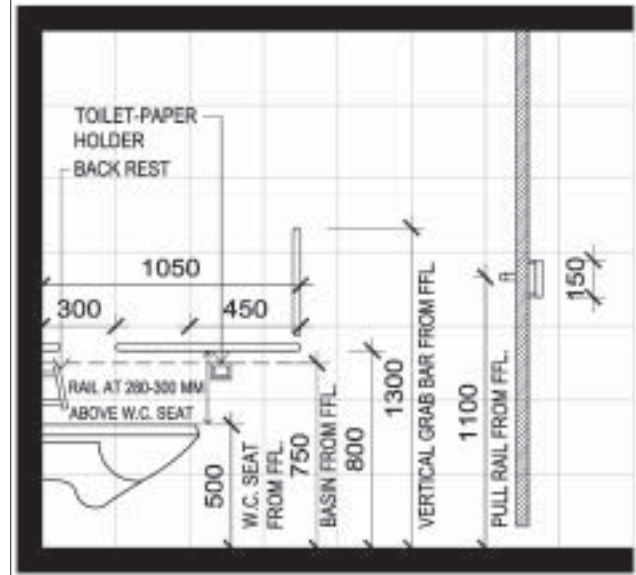

- The W.C. should be located not less than 300 mm and not more than 460 mm away from the adjacent wall with a clear dimension of 750 mm from the front edge of the W.C. to the rear wall to facilitate side transfer. (fig.77, 79)

- One grab-bar, mounted on the side wall closest to the W.C., must extend from the rear wall to at least 450 mm in front of the W.C. seat. Another one 750 mm long must be mounted behind the W.C. All grab-bars must be able to resist a load of not less than 1.3 kN applied vertically or horizontally. (fig.77 , 79)

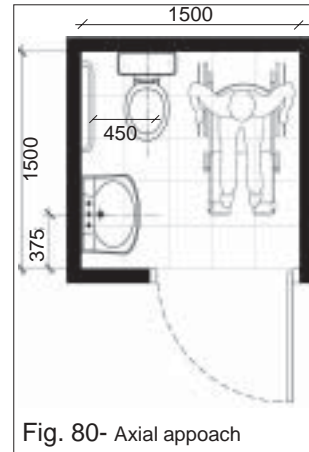
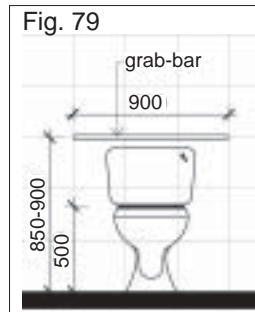
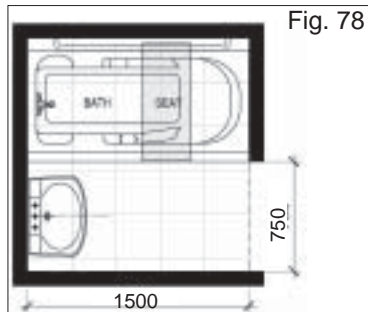

Fig. 80- Axial approach

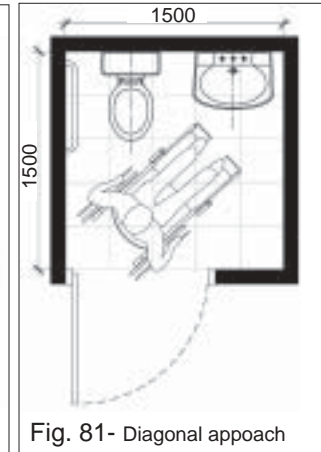

Fig. 81- Diagonal approach

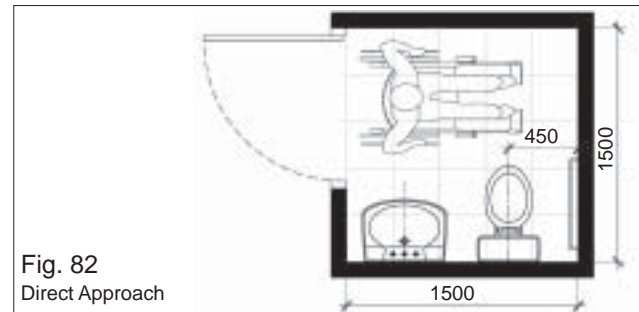
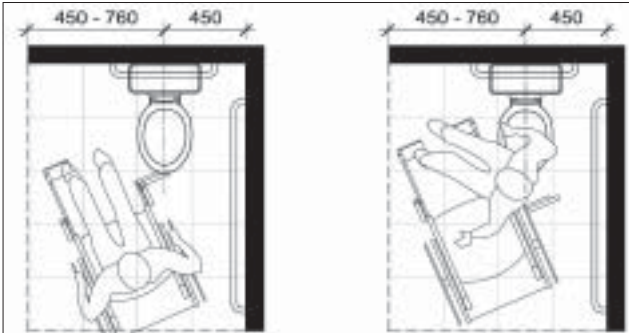

Fig. 82
Direct Approach



Takes transfer position, swings foot rest out of the way, sets brakes.

Fig. 83 a,b-Diagonal transfer



Removes arm-rest, transfers.

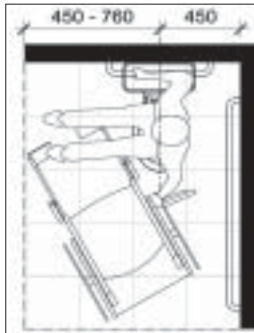

Moves wheelchair out of the way, changes position (some people pivot it or rotate it 90½ to the toilet.

Fig. 84 c,d-Diagonal transfer

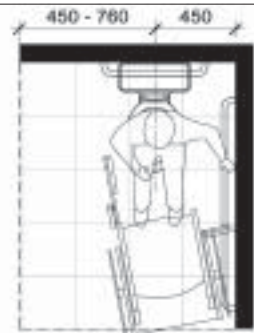

Positions on toilet, releases brakes.

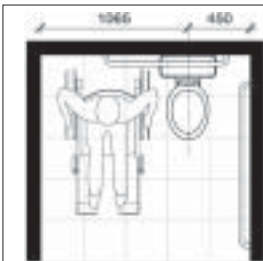

Takes transfer position, swings foot rest out of the way, sets brakes.

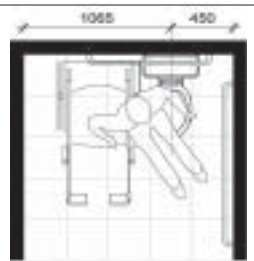

Transfers.

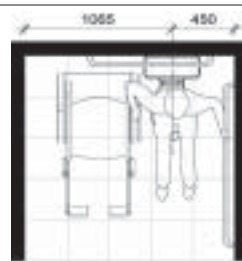

Positions on toilet.

Fig. 85 Side transfer

8.3 - BATHTUBS

- A bathtub may not be suitable for most disabilities. However, if provided, then the following considerations must be incorporated:

- It should have a clear floor space of at least 750 mm width in front of the bathtub. The wash basin may encroach upon this area provided leg and knee space is available below it.(fig. 86, 87)

- A seat 250 mm wide along the entire length or one 400 mm wide minimum along the entire width should be provided and they are preferred on the side opposite the controls for better accessibility. (fig.86)

- Should have grab-bars, one 1200 mm long and located horizontally along the length of the bathtub rim 180 mm to 280 mm above it and the other at least 1200 mm long and located vertically

along the foot of the bathtub adjacent to the clear floor space with the lower end 180 mm above the rim of the tub.(fig.86, 87)

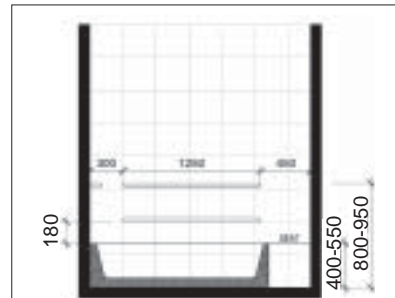

Fig. 86

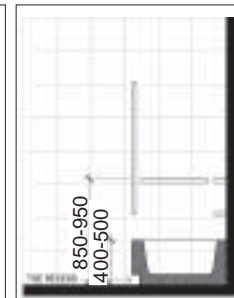

Fig. 87

8.4 - WASH BASINS

- They must be mounted such that the minimum distance between the centreline of the fixture and the side wall is 450 mm. (fig.78)

- The top edge must be between 800 mm and 850 mm from the finished floor level. (fig.88)

- There should be a minimum knee space of 750 mm width by 200 mm depth and 750 mm height with an additional toe space of at least 750 mm width by 230 mm depth by 230 mm height from the finished floor level. (fig.89, 90a)

- It must have a minimum clear floor space of 750 mm width by 1200 mm depth around it, of which a maximum of 480 mm in depth may be under the wash basin. (fig.90b)

- The hot water and drain pipes within the knee space or toe space must be properly insulated.

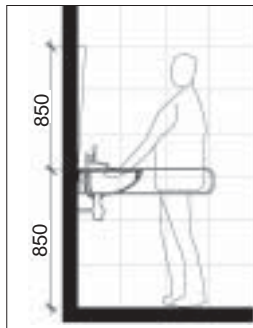

Fig. 88

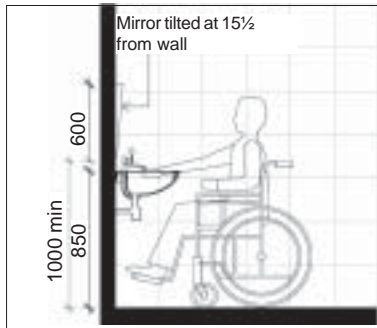
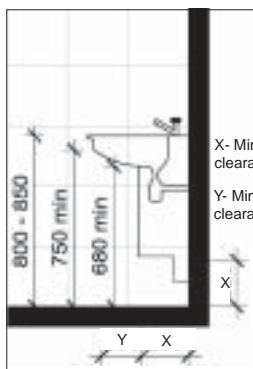
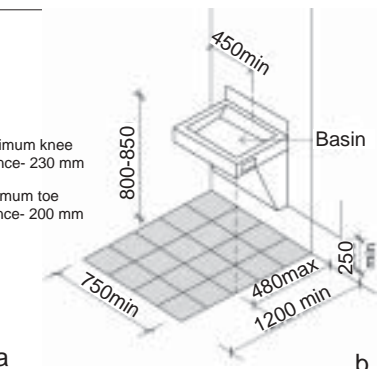

Fig. 89



X- Minimum knee clearance- 230 mm
Y- Minimum toe clearance- 200 mm

Fig. 90



b

8.5 - URINALS

- They should be of the wall hung type with the rim not more than 430 mm from the floor and a clear floor space of 750 mm width x 1200 mm depth without steps in front of it. (fig.91)
- Privacy shields should not extend beyond the urinal unless they are at least 750 mm apart from each other.
- There should be vertical grab-bars on either side extending from 900 mm to 1500 mm above finished floor level and with a minimum of 120 mm between the bar and the wall. (fig.91)
- The flush, if manually operated, should be located between 900 mm and 1200 mm from the finished floor level.

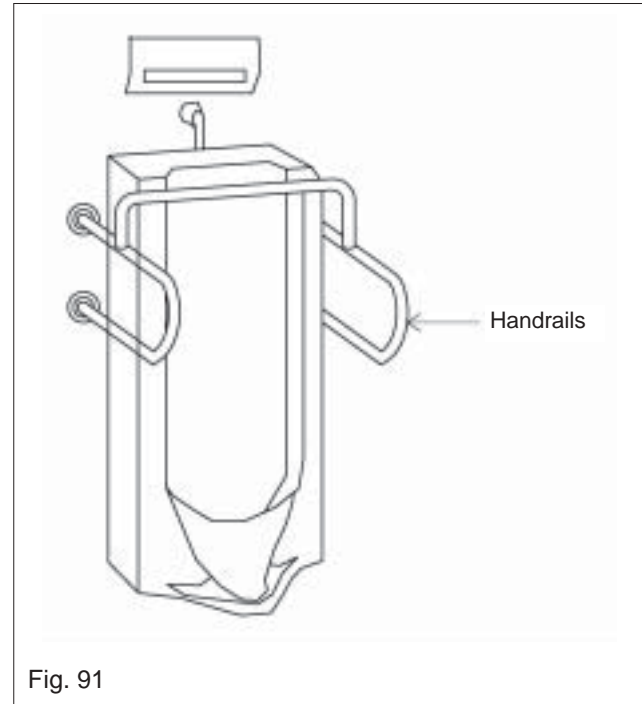

8.6 - WASHROOM ACCESSORIES

- The mirror must be installed in a way such that the bottom edge is at a height not more than 1000 mm from the finished floor level at an angle of $15\frac{1}{2}$ from the vertical to facilitate wheelchair users. (fig.89)

- Towel and soap dispensers, hand dryers and waste bins must be positioned such that the parts and controls for operation are between 900 mm and 1200 mm from the finished floor level. (fig.93)

- Accessories should be placed in close proximity to the accessible basin, to avoid a person with wet hands having to wheel a chair. (fig.93)

- Only lever-type faucets should be used. Single lever-operated faucets/mixers are preferred to double-levered faucets. (fig.92)

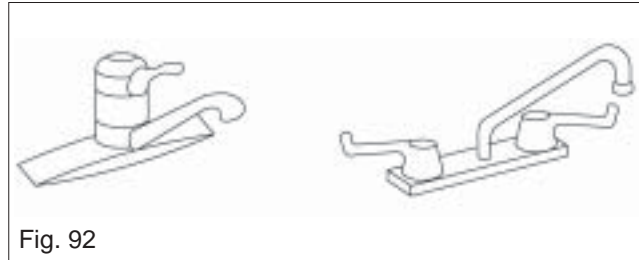

Fig. 92

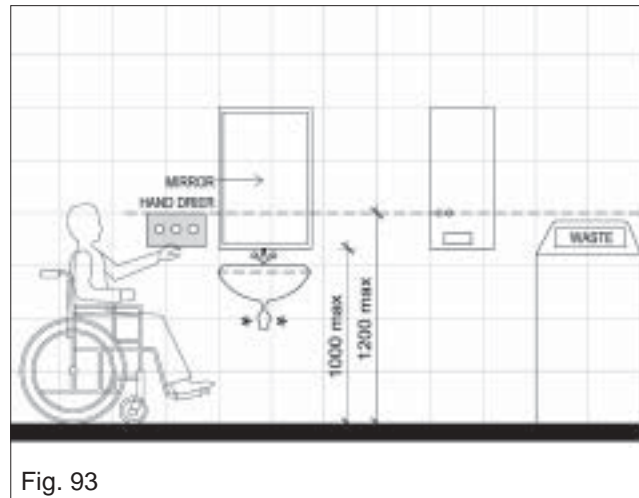

Fig. 93

- Bathtub faucets should be located at the foot of the bathtub and not more than 450 mm above the rim of the bathtub.

- It must require a force less than 22 N to activate.

- Grab-bars should be slip-resistant with rounded edges, preferably knurled, and be installed at a height of 800-900 mm from the finished floor level. They must be not less than 30 mm in dia and not more than 40 mm with a clearance not less than 35 mm and not more than 45 mm from the wall. They must be able to withstand a pressure not less than 1200 N from any direction.

09 - DRINKING WATER FOUNTAINS

- Clear knee space provided below the fountain should not be less than 750 mm high and 230 mm deep. (fig.94, 95)

- Height and clear toe-space should not be less than 750 mm wide, 230 mm deep and 230 mm high from the finished floor level. (fig.94)

-A clear floor space 800 mm x1300 mm should be provided in front of the fountain for manoeuvring the wheelchair. (fig.95)

-Control mechanism should be push or lever type. (fig.94)

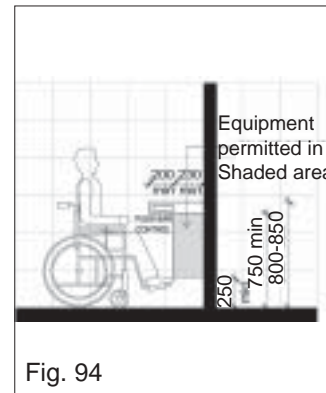

Fig. 94

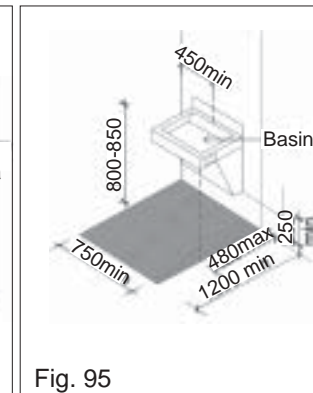

Fig. 95

10- KITCHENS

10.1- MANDATORY

- A minimum clear space of 1500 mm dia. must be provided between the counter and the opposite wall to facilitate wheelchair turning (fig 96, 97, 99)

- Shelves should be such that they are not more than 500 mm deep and not more than 1200 mm high from finished floor level. There should be a minimum gap of 400 mm between the edge of the work-top and the lower edge of the upper shelves. (fig 98)



Fig. 96

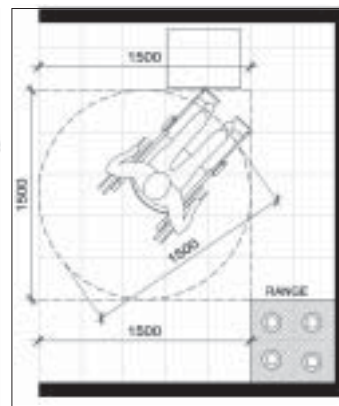

Fig. 97

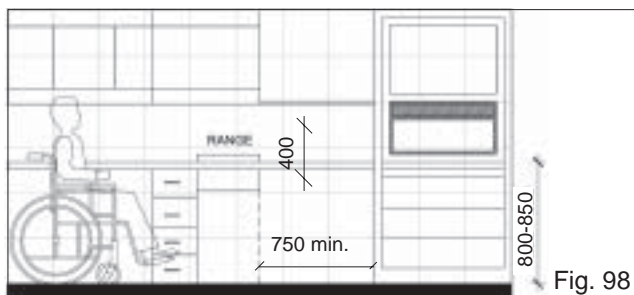

Fig. 98

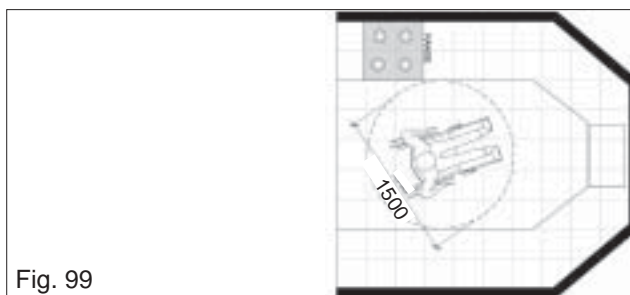

Fig. 99

Work tops, sinks and the cooking area should be at the same level at a height of 800 - 850 mm (fig.100)

- A knee room of 750 mm must be provided below the sink. (fig.100)

- To facilitate wheelchair accessibility work areas such as counter tops for cutting counters washing and cooking range, platforms etc. should be 800 - 850 mm high from the finished floor level and should provide space beneath them for legroom with a minimum of 750 mm width and 230 mm depth. (fig.100, 102)

- For wheelchair users side reach for the lower shelves or drawers (base) must be 250 mm from the finished floor level. (fig.101)

10.2 - SUGGESTIVE

- Base cabinets with hinged doors or fixed shelves should be avoided. It is preferable to use base drawers of various depths along with vertical pullout units on either sides.



Fig. 100



Fig. 101

10.3- SERVICE COUNTERS

- Counters to serve the disabled should be designed for parallel approach with a height of 800 mm from the finished floor level, 1200 mm width and 500 mm depth. It should have a knee space at least 750 mm high, 900 mm wide and 480 mm deep.

- It should have a minimum of 1200 mm x 900 mm space in front of the counter for manoeuvring.

- Shelves above such counters to be accessed by wheelchair users should not be more than 1250 mm from the finished floor level.

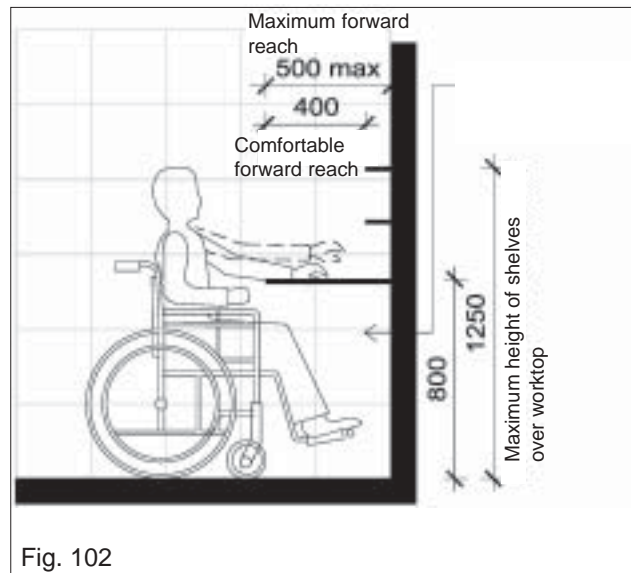

Fig. 102

11 - STORAGE

11.1 - CLEAR FLOOR SPACE

- A clear floor space at least 750 mm x 1200 mm that allows either a forward or parallel approach by a person using a wheelchair shall be provided at accessible storage facilities.

11.2 - HEIGHT

- Clothes rods or shelves shall be a maximum of 1250 mm above the finished floor level for a side approach. where the distance from the wheelchair to the clothes rod or shelf exceeds 255 mm, as in closets without accessible doors, the height of the rod must not exceed 1200 mm from the finished floor level and its depth must not exceed 500 mm from the user. (fig.103, 104)

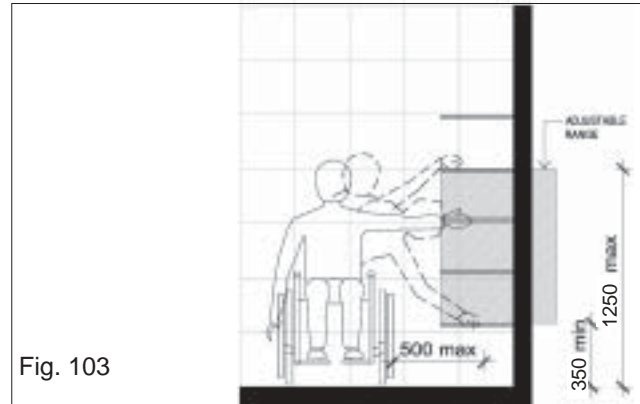

Fig. 103

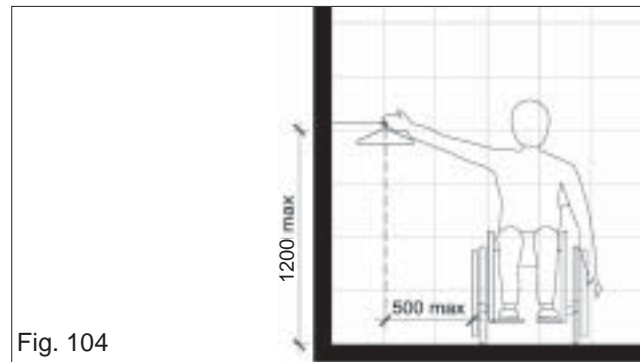
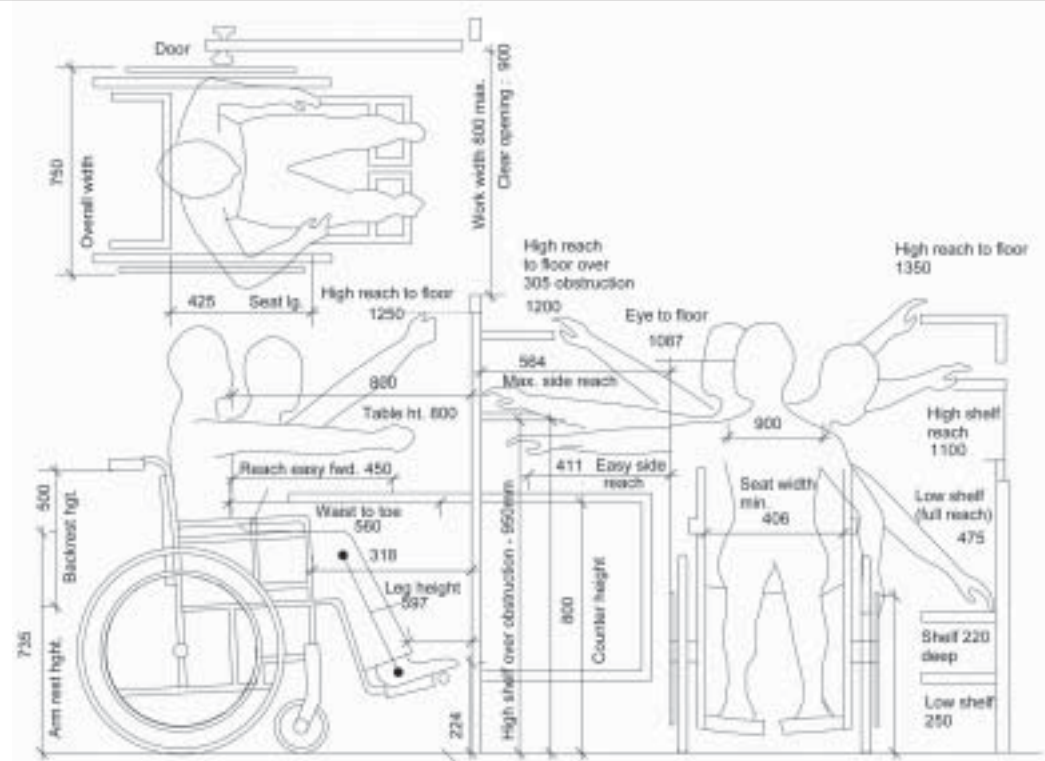

Fig. 104

Fig. 105



12 - TELEPHONES

- Public telephones required to be accessible under Section 3.1 shall comply with Section 12.

12.1 CLEAR FLOOR OR GROUND SPACE

- A clear floor or ground space at least 750 mm x 1200 mm that allows either a forward or parallel approach by a person using a wheelchair shall be provided at telephones. (fig.106 and 107)

- The clear floor or ground space shall comply with Section 3.3.

- Bases, enclosures and fixed seats shall not impede approaches to telephones by people who use wheelchairs.

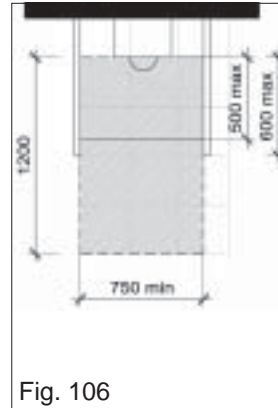

Fig. 106

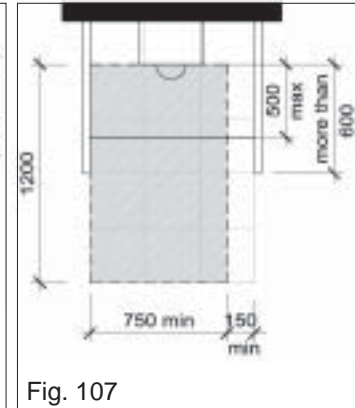

Fig. 107

12.2 CONTROLS

- Telephones shall have pushbutton controls where service for such equipment is available.

12.3 - MOUNTING HEIGHTS

- The highest operational part of the telephone shall be within the reach-ranges specified in Section 2.1 (fig.108, 109)

12.4 - PROTRUDING OBJECTS

- Telephones shall comply with Section 4.2

12.5 - HEARING AID COMPATIBLE AND VOLUME CONTROL TELEPHONES

- As per requirement of Section 3.1, the minimum required number of telephones shall be hearing aid compatible.

- Volume controls, capable of a minimum of 12 dbA and a maximum of 18 dbA above normal, shall be provided. If an automatic reset is provided then 18 dbA may be exceeded.

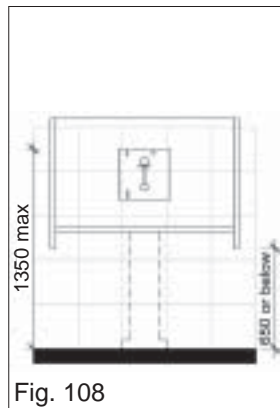

Fig. 108

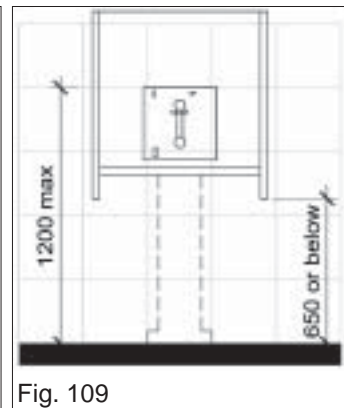

Fig. 109

12.6 TELEPHONE BOOKS

- Telephone books, if provided, shall be located in a position that complies with the reach ranges specified in Section on Reach Ranges (14.2).

12.7 CORD LENGTH

- The cord from the telephone to the handset shall be at least 750 mm long.

12.8 TEXT TELEPHONES

- Text telephones used with a pay telephone shall be permanently affixed within, or adjacent to, the telephone enclosure. If an acoustic coupler is used, the telephone cord shall be sufficiently long to allow connection of the text telephone and the telephone receiver.

- Pay telephones designed to accommodate a portable text telephone shall be equipped with a shelf and an electrical outlet within or adjacent to the telephone enclosure. The telephone handset shall be capable of being placed flush on the surface of the shelf. The shelf shall be capable of accommodating a text telephone and

shall have (152 mm) minimum vertical clearance in the area where the text telephone is to be placed.

- Equivalent facilitation may be provided. For example, a portable text telephone may be made available in a hotel at the registration desk if it is available on a 24-hour basis for use with nearby public pay telephones. In this instance, at least one pay telephone shall comply with paragraph 2 of this Section.

- In addition, if an acoustic coupler is used, the telephone handset cord shall be sufficiently long so as to allow connection of the text telephone and the telephone receiver.

- Directional signage shall be provided and shall comply with Section 01.

13- FIXED OR BUILT-IN FURNITURE (SEATING, BENCHES, TABLES)

- Fixed seating should be installed such that they provide free passage to all people with minimum 900 mm space. They should be provided at every 30 mts along a barrier-free path of travel within an institution. (fig. 110)

- Local textural changes may be incorporated into the paving for identification of such public amenities by disabled persons. If fixed bench/seat projects out without any connection to the floor then there must be an upturn from the floor finish or tactile rendering around it detectable by the visually impaired by the white stick.

- Public seats and benches should be 450 mm high from the finished floor level and should have a backrest at about 700 mm above the finished floor level.

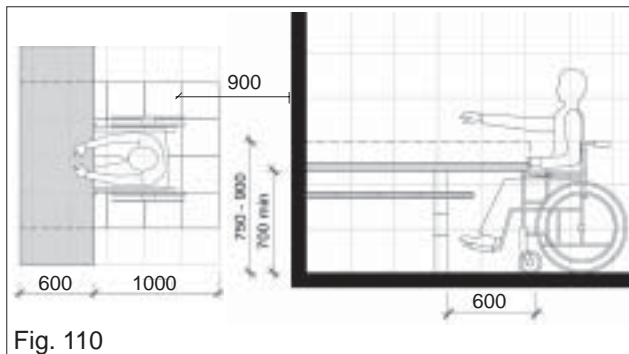

Fig. 110

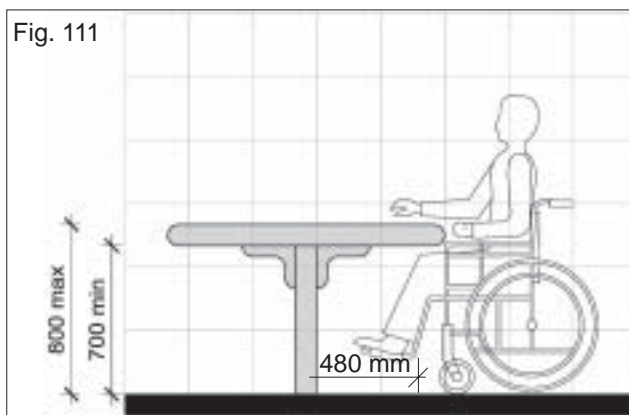
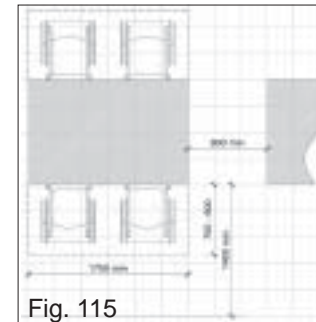
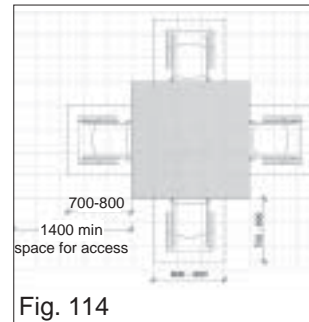
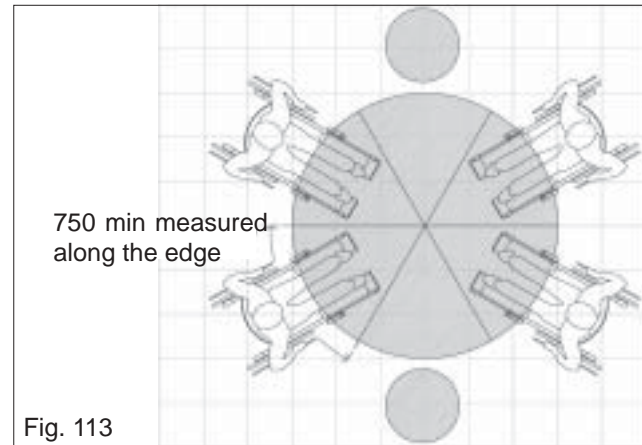
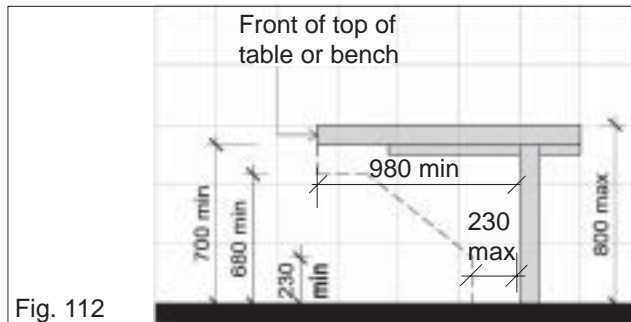

Fig. 111

- Accessible benches should allow a minimum space of 900 mm x 1400 mm adjoining them for the wheelchair. They should be stable to withstand side thrusts and provide minimum toe space of 300 mm. They should have arms and back-rests. (fig. 114, 115)

- The height of the tables should be between 750 mm and 900 mm and the minimum depth under a table should be at least 600 mm such that a wheelchair may fit in from under all sides. (fig. 112)



14 - AUTOMATED TELLER MACHINES

- Each automated teller machine required to be accessible by Section 3.1 shall be on an accessible route and shall comply with Section 14

14.1 CLEAR FLOOR SPACE

- The automated teller machine shall be located so that clear floor space complying with Section 3.3 is provided to allow a person using a wheelchair to make a forward approach, a parallel approach, or both, to the machine.

14.2 REACH RANGES

14.2.1 Forward Approach Only

- If only a forward approach is possible, operational parts of all controls shall be placed within the forward reach range specified in Section 3.3.

14.2.2 Parallel Approach Only

- If only a parallel approach is possible, operational parts of controls shall be placed as follows:

1. Reach Depth Not More Than 255 mm

- Where the reach depth to the operational parts of all controls as measured from the vertical plane perpendicular to the edge of the unobstructed clear floor space at the farthest protrusion of the automated teller machine or surround is not more than 255 mm, the maximum height of the control above the finished floor or grade shall be 1200 mm.

2. Reach depth More Than 255 mm

- Where the reach depth to the operational parts of any control as measured from the vertical plane perpendicular to the edge of the unobstructed clear floor space at the farthest protrusion of the automated teller machine or

surround is more than 255 mm, the maximum height above the finished floor or grade shall be less than 1200 mm.

3. Forward and Parallel Approach

- If both forward and parallel approaches are possible, operational parts of controls shall be placed within at least one of the reach ranges in paragraphs (1) or (2) of this Section.

4. Bins:

- Where bins are provided, for envelopes, waste paper, or other purposes, at least one of each type provided shall comply with the reach ranges and be appropriately marked.

14.3 - CONTROLS

- Controls for user activation shall comply with Section 16.

14.4- EQUIPMENT FOR PERSONS WITH VISION IMPAIRMENTS

- Instructions and all information for use shall be made accessible to and independently usable by persons with vision impairment.

14.5 - EXCEPTION

- Where a function can be performed in a substantially equivalent manner by using an alternative control, only one of the controls needed to perform that function is required to comply with this Section. If the controls are identified by tactile markings, such markings shall be provided on both controls.

15 - ALARMS

15.1 LOCATION

- At a minimum, visual signal appliances shall be provided in buildings and facilities in each of the following areas: rest-rooms and any other general use areas (e.g. meeting rooms), hallways, lobbies, and any other area for common use.

15.2 AUDIBLE ALARMS

- If provided, audible emergency alarms shall produce a sound that exceeds the prevailing equivalent sound level in the room or space by at least 15 dbA or exceeds any maximum sound level with a duration of 60 seconds by 5 dbA, whichever is louder.

- Sound levels for alarm signals shall not exceed 120 dbA.

15.3 VISUAL ALARMS

- Visual alarm signal appliances shall be integrated into the building or facility alarm system. If single station audible alarms are provided then single station visual alarm signals shall be provided.

- Visual alarm signals shall have the following minimum photometric and location features:

- 1. The lamp shall be a xenon strobe type or equivalent.
- 2. The colour shall be clear or nominal white (i.e. unfiltered or clear filtered white light)
- 3. The maximum pulse duration shall be two-tenths of one second [0.2 sec] with a maximum duty cycle of 40 per cent. The pulse duration is defined as the time interval between initial and final points of 10 per cent of maximum signal.
- 4. The intensity shall be a minimum of 75 candelas.

- 5. The flash rate shall be a minimum of 1 Hz and a maximum of 3 Hz.
- 6. The appliance shall be placed 2000 mm above the highest floor level within the space, or 150 mm below the ceiling, whichever is lower.
- 7. In general, no place in any room or space required to have a visual signal appliance shall be more than 15 mts from the signal [in horizontal plane]. In large rooms and spaces exceeding 30 mts across, without obstructions 2 mts above the finished floor level, such as auditoriums, devices may be placed around the perimeter, spaced a maximum 30 mts apart, in lieu of suspending appliances from the ceiling.
- 8. No place in common corridors or hallways in which visual alarm signalling appliances are required shall be more than 15 mts from the signal.

15.4 AUXILIARY ALARMS

- Units and sleeping accommodations shall have a visual alarm connected to the building emergency alarm system or shall have a standard 110-volt electrical receptacle into which such an alarm can be connected and a means by which a signal from the building emergency alarm system can trigger such an auxiliary alarm. When visual alarms are in place, the signal shall be visible in all areas of the unit or room. Instructions for use of the auxiliary alarm or receptacle shall be provided.

16 - CONTROLS AND OPERATING MECHANISMS

- Controls and operating mechanisms required to be accessible under Section 3.1 shall comply with the following:

16.1 CLEAR FLOOR SPACE

- Clear floor space complying with Section 3.3 that allows a forward or a parallel approach by a person using a wheelchair shall be provided at controls, dispensers, receptacles, and other operational equipments.

16.2 HEIGHT

- The highest operational part of controls, dispensers, receptacles, and other such operable equipment shall be placed within at least one of the reach ranges specified in Section 3.2. (fig.116)

- Electrical and communications system receptacles on walls shall be mounted no less than 380 mm above the floor level.

16.3 OPERATION

- Controls and operating mechanisms shall be operational with one hand and shall not require tight grasping, pinching or twisting of the wrist. The force required to activate controls shall be no greater than 22.2 N.

16.4 - EXCEPTION

- These requirements do not apply where the use of special equipments dictates otherwise or where electrical and communications systems receptacles are not normally intended for use by building occupants.

Fig. 116 - Accessible heights for various controls.

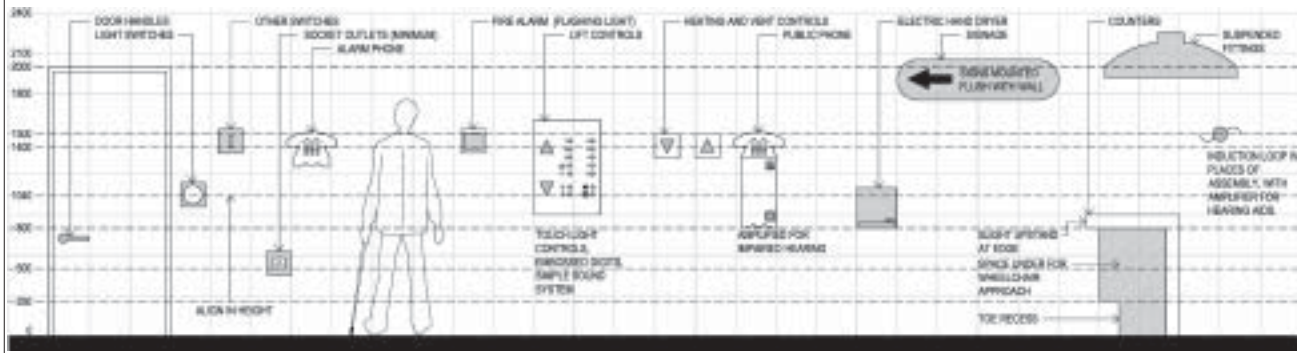

- 1. ADA Accessibility Guidelines for Buildings and Facilities (ADAAG)**
US: American Disabilities Act
- 2. Accessibility for the Disabled, A Design Manual for a Barrier-Free Environment**
SOLIDERE, Lebanon
United Nations (Economic and Social Commission for Western Asia)
Ministry of Social Affairs, National Committee for the Disabled -U.S.A.
- 3. Guidelines & Space Standards For Barrier-Free Built Environment For Disabled & Elderly Persons**
CPWD, Ministry of Urban Affairs & Employment, India, 1998
- 4. McGill Standards for Barrier-Free Campus**
Office for Students with Disabilities
Office of Physical Resources
McGill University, Canada, 1996
- 5. Planning A Barrier-Free Environment**
Office of the Chief Commissioner for the Persons with Disabilities, Govt. of India.2001
- 6. The PWD Act, 1995**
- 7. American Disabilities Act**
- 8. Sign Design Guide**
JMU Access Partnership.
- 9. The Universal Design File**
- 10. The National Building Code of India**
- 11. Success and Ability**
Laila Ollapally
Ability Foundation, Chennai, May 2002
- 12. The Gazette of India.**
Extraordinary Part II – Section I
Government of India, January 1996

Environmental Planning Collaborative

Established in Ahmedabad in 1996, it is a non-profit professional planning and development management company that undertakes research, advocacy, capacity building and professional consultancy services. EPC works primarily with urban local bodies and a variety of other agencies involved in planning and development, such as state government departments, international funding and lending agencies, and non-governmental organizations (NGOs). Its work spans a wide range of developmental issues including urban planning, urban design, urban management, regional and environmental planning, urban transport, heritage conservation, development regulations, disaster management and natural resources management. Its projects are undertaken in a collaborative manner with significant involvement from the client and other related agencies.



Handicap International (HI)



An international non-government organisation, it has been present in India since 1988. HI works to support actions towards an inclusive, barrier-free and rights-based society for persons with disabilities and other vulnerable persons in India. To this end HI works with people, local and international organisations and Governments which share the vision of an inclusive society where vulnerable people have equal rights and opportunities and live their lives with dignity, experience joy as well as a sense of fulfilment, irrespective of the cause, nature and the environment underlying the situation. People are understood to include persons with disabilities and other persons in situations of vulnerability, their families and their communities, irrespective of religion, caste or creed.

HCP Design and Project Management Pvt. Ltd.

A design and management company in Ahmedabad, it was established in 1961. Previously known as Messrs. Hasmukh C. Patel, Architects and Planners, HCPDPM has extensive experience in architectural design, construction management, interior design and urban design, with projects including educational campuses, institutional buildings, townships, recreational buildings and factories. Its design philosophy has a basic insistence on clarity and simplicity in design, and its projects have drawn consistently from this modernist and functional aesthetic. With focus remaining squarely on architecture and urban design, the firm frequently extends its concern through partnering with the Environmental Planning Collaborative (EPC), a planning and development management company; and TDW Pvt. Ltd., a furniture design/manufacturing firm.



Mind's Eye Design



A design, engineering and architectural consultancy, started in 1988, it is among the few such integrated consultancies in the country. Its design process integrates aesthetics with technology, material science, ergonomics, value engineering, cultural aspects, production details and final implementation. This holistic approach to all design solutions is the backbone of its philosophy. It has been involved in product design, signage design, corporate identity and graphics design, space and exhibition design and design for special needs such as of children, old people and the less abled. It is also involved in academia like the National Institute of Design (NID), Mudra Institute of Communication (MICA), National Institute of Fashion Technology (NIFT), Shrishti School of Design (Bangalore) and the School of Interior Design (SID).

UNNATI - Organisation for Development Education



A voluntary non-profit organisation, it was registered under the Societies Registration Act (1860) in 1990. Currently, we are engaged in providing strategic issue-based support to development initiatives in Gujarat and Rajasthan. The primary aim is to promote social inclusion and democratic governance so that the vulnerable sections of our society are empowered to effectively participate in the mainstream development and decision-making processes. The above aim is accomplished through undertaking collaborative research, public education, advocacy, direct field-level mobilisation and implementation with multiple stakeholders. While we work at the grassroot level to policy level environment for ensuring basic rights of citizens, we derive inspiration from the struggles of the vulnerable and strength from the partners.

Vastu Shilpa Foundation For Studies and Research in Environmental Design



A non-profit, non-Government public charitable trust in Ahmedabad, it was established in 1978. Research, Research Application and Demonstration being the tri-fold activities, it has been involved in pioneering research to evolve indigenous design norms and planning standards which are rooted to the socio-cultural milieu as well as appropriate to its resource base. Settlement design, heritage conservation, sustainable built environment, appropriate technology, design theories are some of the areas of its concern. Vastu Shilpa Foundation, as a bridge between academics and practice, has realized large-scale housing, urban design and city planning projects, and has brought out a number of publications based on its first-hand research.

Environmental Planning Collaborative (EPC)	<p>PARITOSH, Usmanpura, Ahmedabad -380013, India Phone: (079) 27550102, 27553069 Fax: 27550649, 27552924 Web: www.epconnet.com, E-mail: info@epconnet.com</p>
Handicap International	<p>Rupdip, 39, Sudarshan Society, Part-II, Naranpura, Ahmedabad - 380013, India Phone: (079) 55425646, Email: inclusion@hi-india.org</p>
HCP Design and Project Management	<p>PARITOSH, Usmanpura, Ahmedabad -380013, India Phone: (079) 27550875, 27552563, 27552442 Fax: 27552924 Web: www.hcponnet.com, E-mail: hcpahd@hcponnet.com</p>
MIND'S EYE DESIGN Private Limited	<p>No. 703 H. K. House, Ashram Road Ahmedabad 380 009, India Tel: +91-79 - 26581467; Mob : +91-9824021607</p>
UNNATI - Organisation for Development Education	<p>G -1 / 200, Azad Society, Ahmedabad - 380 015, India Phone: (079) 26746145, 26733296 Email: unnatiad1@sancharnet.in</p>
Vastu Shilpa Foundation for Studies and Research in Environmental Design,	<p>SANGATH, Near Drive-In Cinema, Thaltej, Ahmedabad, 380054, India Phone : (079) 27451555 Fax : 27452006 Web: www.vastushilpa.org, E-mail : vsfad1@sancharnet.in</p>

APPENDIX

STATUTORY AND REGULATORY PROVISIONS

Legislation

CH. VIII - NON-DISCRIMINATION

CH. V. EDUCATION

REGULATIONS – A BRIEF

- 1) National Building Code of India, 1983
 - 2) The Guidelines and Space Standards for a Barrier-Free Built Environment for Disabled and Elderly Persons (CPWD)
 - 3) Ahmedabad General Development Control Regulations
 - 4) Delhi Building Access By-laws
-

STATUTORY AND REGULATORY PROVISIONS

There are various statutory and regulatory provisions that encourage and promote incorporation of barrier-free features in public spaces, facilities and services. Relevant portions from a few of them are given below:

LEGISLATION

The Persons With Disabilities (Equal Opportunities, Protection of Rights and Full Participation) Act, 1995 – also known as the PWD Act 1995.

This Act, passed by the Indian Parliament in January 1996, seeks to protect the rights of persons with disabilities and provide them equal opportunities in various spheres. Some of the clauses which refer to accessibility are given here -

CH. VIII - NON-DISCRIMINATION

44. Establishments in the transport sector shall, within the limits of their economic capacity and development for the benefit of persons with disabilities, take special measures to-

- a. adapt rail compartments, buses, vessels and aircraft in such a way as to permit easy access to such persons;
- b. adapt toilets in rail compartments, vessels, aircraft and waiting rooms in such a way as to permit the wheelchair users to use them conveniently.

45. The appropriate Governments and the local authorities shall, within the limits of their economic capacity and development, provide for -

- a. installation of auditory signals at red lights in the public roads for the benefit of persons with visual handicap;
- b. causing curb cuts and slopes to be made in pavements for the easy access of wheelchair users;
- c. engraving on the surface of the zebra crossing for the blind or for persons with low vision;
- d. engraving on the edges of railway platforms for the blind or for persons with low vision;
- e. devising appropriate symbols of disability;
- f. warning signals at appropriate places.

46. The appropriate Governments and the local authorities shall, within the limits of their economic capacity and development, provide for -

- a. ramps in public buildings
- b. adaptation of toilets for wheelchair users

- c. Braille symbols and auditory signals in elevators or lifts
- d. ramps in hospitals, primary health centres and other medical care and rehabilitation institutions.

CH. V. EDUCATION

30. Without prejudice to the foregoing provisions, the appropriate Governments shall by notification prepare a comprehensive education scheme which shall make provision for

(b) the removal of architectural barriers from schools, colleges or other institutions imparting vocational and professional training;

Source: The above summary is based on the full PWD Act, 1995 as well as The Gazette of India, Extraordinary Part II – Section I, published by Authority, New Delhi, Monday, January 1, 1996 / Pausa 11, 1917 – Ministry of Law, Justice and Company Affairs (Legislative Department).

REGULATIONS – A BRIEF

Provisions and regulations for providing features of accessibility for people with disabilities are guided by two items of national regulations: the National Building Code of India and the IS: 4963 - 1968: Recommendations for Buildings and Facilities for the Physically Handicapped.

1) National Building Code of India, 1983

Revised in 2003, Part III (Clause 12.21), Appendix E - Special Requirements for Planning of Public Buildings Meant for Use of Physically Handicapped issued by the Bureau of Indian Standards. These provide design standards for site planning and development for various aspects, including walks and parking lots, design of building components like ramps, entrances, doors and doorways, stairs, floors, toilet rooms, designing for children, etc. The National Building

Code also includes a list of several standards, which are acceptable as 'good practice', and 'accepted standards' in the context of the NBC. These may be used by Development Authorities as a guide in conformity with the requirements of the referred Clauses in the Code. Significant among these is the IS: 4963 - 1968: Recommendations for Buildings and Facilities for the Physically Handicapped.

However, these regulations provide guidelines for adoption of building by-laws in different States and are not made mandatory across the country. Most cities that have barrier-free regulations have based them on these standards.

2) The Guidelines and Space Standards for Barrier Free Built Environment for Disabled and Elderly Persons (CPWD)

These are issued by the CPWD, Ministry of Urban Affairs and Employment: These provide guidelines for location and placement of controls and their height and range of comfortable reach, location of facilities like counters, telephone booths, water fountains, mailboxes, vending machines, road crossing and taxi stand designs. Minimum access provisions required in various types of buildings (these cover single detached, single dwelling units, staff housing, multiple dwelling and high rise residential units and tenements, tenement houses, row houses, apartments and town houses, post offices, banks and financial service institutions, shop-houses and single-storey, places of worship, food centres, community centres, village halls, auditoria, concert halls, assembly halls, cinemas, theatres and other places of public assembly).

3) Ahmedabad General Development Control Regulations

In Ahmedabad, the disability regulations are defined within Chapter 28 “To Provide Facilities for Physically Handicapped Persons” of the General Development Control Regulations. These include regulations for site planning and development like parking and access as well as regulations for building design for elements like staircases, ramps, doors and windows, toilets, etc.

4) Delhi Building Access By-laws

The Ministry of Urban Development and Poverty Alleviation has issued a public notice proposing amendments to the Unified Building By-laws, 1983, pertaining to the National Capital Territory of Delhi, with a view to providing a barrier-free environment in public buildings for persons with disability and are applicable to all buildings,

recreational areas and facilities used by the public (domestic residences are exempt).

It seeks to identify the disabilities which include impairments that cause individuals to use wheelchairs; impairments that cause individuals to walk with difficulty or insecurity; individuals using braces or crutches, amputees, arthritics, spastics and those with pulmonary and cardiac ills; such hearing disabilities that might make an individual insecure in public areas because he is unable to communicate or hear warning signals; as well as sight disabilities. It specifies that every public building should have at least one access to main entrance/exit to the disabled, which shall be indicated by proper signage. This entrance shall be approached through a proper ramp together with stepped entry. Access path from the plot entry and surface parking to building entrance will have even surface without any step. Slope, if any shall not have gradient greater than

5 percent and use of appropriate floor material to guide visually impaired persons.

For parking of vehicles of disabled persons, surface parking for two equivalent car spaces shall be provided near the entrance for the physically challenged persons with maximum travel distance of three metres from building entrance. It takes care of specified facilities such as approach to plinth level, corridor connecting the entrance/exit for the handicapped, stairways, lift, toilet and drinking water. While Braille signage shall be provided at the above-specified facilities, the notice also calls for provision of ramps with non-slip material at the entry to the building.

Guiding floor materials or devices that emit sound shall be provided to guide the visually impaired persons in the corridor connecting the entrance and exit for the handicapped. Stairways with open riser and provision of nosing are not

permitted in such buildings. Wherever lift is required as per by-laws, provision of at least one lift shall be made for the wheelchair user with specified cage dimensions and Braille signage. It provides for one special WC in a set of toilet to be provided for the use of the handicapped.

An alternative to immediate evacuation of a building via staircases and/or lifts is the movement of persons with disability to safety areas within a building. If possible, they could remain there until fire is controlled or extinguished or until rescued by fire-fighters. It is useful to have the provision of a refugee area, usually at the fire protected stair-landing on each floor that can safely hold one or two wheelchairs.

Note: Many other states, union territories and city development authorities have provisions and by-laws similar to above.

PARTNERS IN ACCESSIBILITY MOVEMENT

Individuals

Ashkha Naik, Amit Sheth, Anagha Muzumdar, Anand Patel, Archana Shrivastav, Arindam Mitra, Arpit Dutt, Aruna Khasgiwala, B R Balachandran, Balkrishna Doshi, Bhushan Punani, Bimal Patel, Bindu Nair, Binoy Acharya, Brinthalakshmi Subramanian, D Nanda, Deepa Sonpal, Dilip Mehta, Geeta Sharma, Govind Kerai, Hasmukh Patel, Jyotish Chowdhary, Kamal Mangaldas, Kanchan Patel, Kahan Vyas, Karan Grover, Kinnari Desai, Lalit Baveja, M M Patel, Mahesh Dayalan, Meghna Patel, Members of the Media, Mitul Shukla, Nandini Rawal, Narendra Amin, Nimish Patel, O Ravi, Prabha Mehta, Pradeep Makhijani, Praveen Nahar, Raajesh Moothan, Rohit Patel, S Balaram, Sanjay Dave, Shankharupa Damle, Sushma Oza, Sweta Bhayut, Uday Shelat, Vishnuprasad Raval, Vijay Matai, Vijay Patel, Yatin Pandya

Institutions

Abhikram / Panika, Ahmedabad Municipal Corporation, Ahmedabad Study Action Group, Blind People's Association, Centre for Environmental Planning and Technology, Charkha, Commissioner of Disabilities-Gujarat, Department of Architecture-M.S. University, DISHA, Eklavya Education Foundation, Environmental Planning Collaborative, Faculty of Social Work-M.S. University, Handicap International, HCP Design and Project Management Pvt. Ltd, ICICI Bank, Mind's Eye Design, National Institute of Design, Parakh, Planet Health, Shri Navchetan Blind Men's Association, Shri Yuva Viklang Mandal, United Way of Baroda, UNNATI -Organisation for Development Education, Vastu Shilpa Foundation

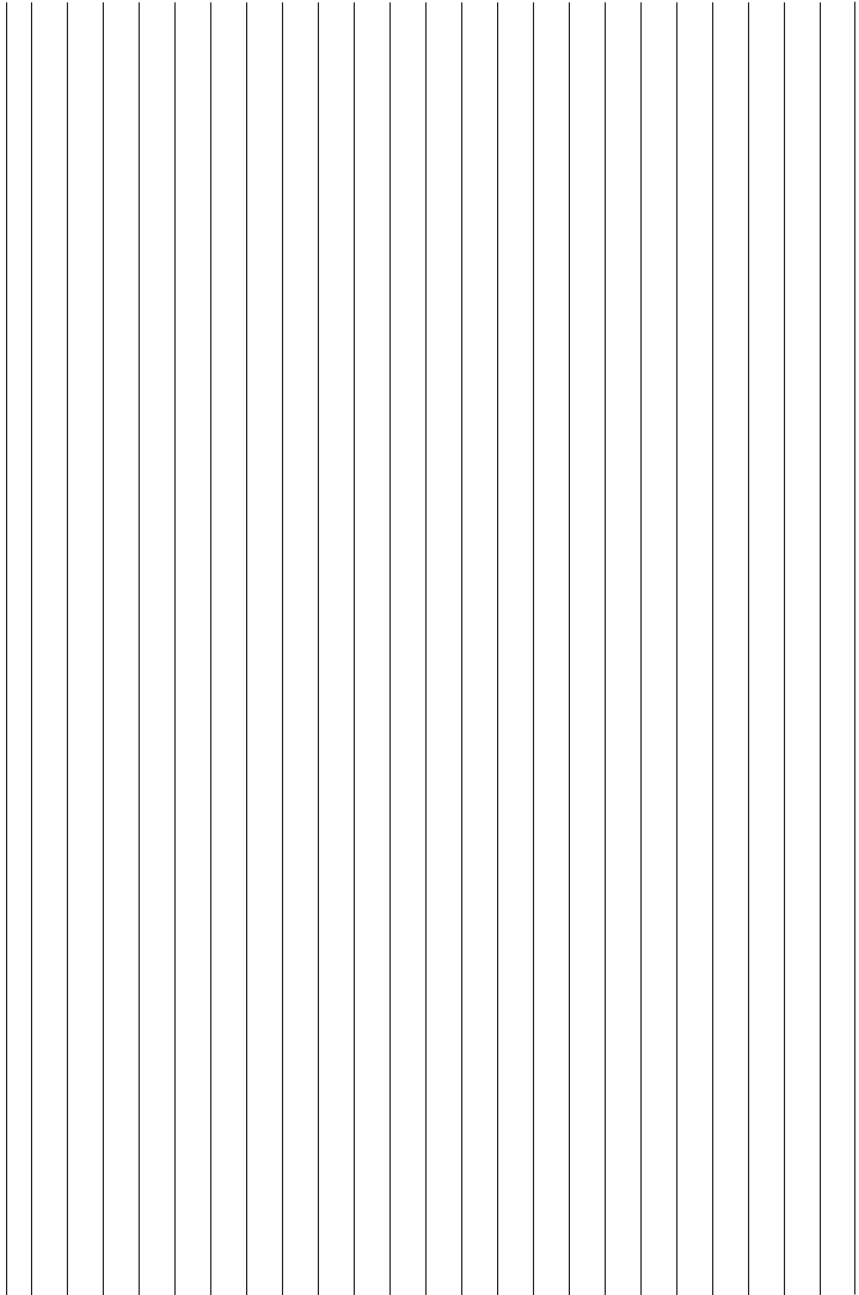

N O T E S