



Design of Steel Deck for Concentrated and Non-Uniform Loading

JUNE 20, 2018

Copyright © 2018 Steel Joist Institute. All Rights Reserved.



Presented by:

*Cody Trueblood, New Millennium
Mike Antici, NUCOR*





Polling Question

- New requirement to earn PDH credits
- Two questions will be asked during the duration of today's presentation
- The question will appear within the polling section of your GoToWebinar Control Panel to respond



Disclaimer

The information presented herein is designed to be used by licensed professional engineers and architects who are competent to make a professional assessment of its accuracy, suitability and applicability. The information presented herein has been developed by the Steel Joist Institute and is produced in accordance with recognized engineering principles. The SJI and its committees have made a concerted effort to present accurate, reliable, and useful information on the design of steel joists and Joist Girders. The presentation of the material contained herein is not intended as a representation or warranty on the part of the Steel Joist Institute. Any person making use of this information does so at one's own risk and assumes all liability arising from such use.

Learning Objectives



- Recognize load cases that require additional analysis beyond distribution as a uniform load.
- Understand the limit states for design under concentrated loads.
- Examine different load paths for varying concentrated load conditions.
- Review current and **NEW** SDI design methodology for concentrated and cluster loads.
- Demonstrate potential shortcuts to concentrated load design.
- Present example problems for design with concentrated loads.

Presentation Outline

- ✓ Identify Typical Deck Types
- ✓ Introduction to Concentrated Load Types
- ✓ Roof Deck Limit States and Design Example
- ✓ Floor Deck Limit States and Current Design Methodology
- ✓ Composite Deck Design Examples – Shortcuts for Multiple Loads
- ✓ Form Deck and Steel Fibers



Deck Types

Roof Deck

- Permanent Structural Member
- No Concrete Topping



Composite Deck

- Deck and Concrete Work Together
- Embossments – Composite Action



Form Deck

- Deck is Permanent Form
- Deck Often Carries Slab Weight



Concentrated Loads on Roof Deck



Safety Anchors

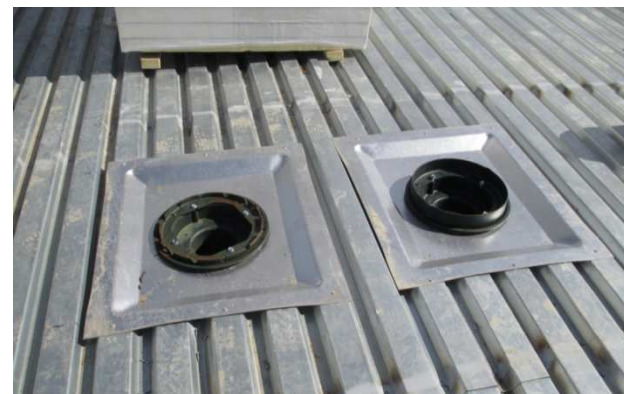

Roof Drains

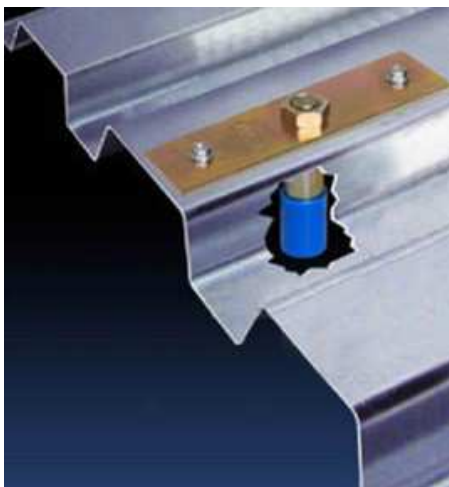

Suspended Loads



Solar Panels

Concentrated Loads on Roof Deck

- People
- Dollies
- Pallets
- Tool Chests
- Roofing Machinery



Concentrated Loads on Floor Deck

Storage Racks

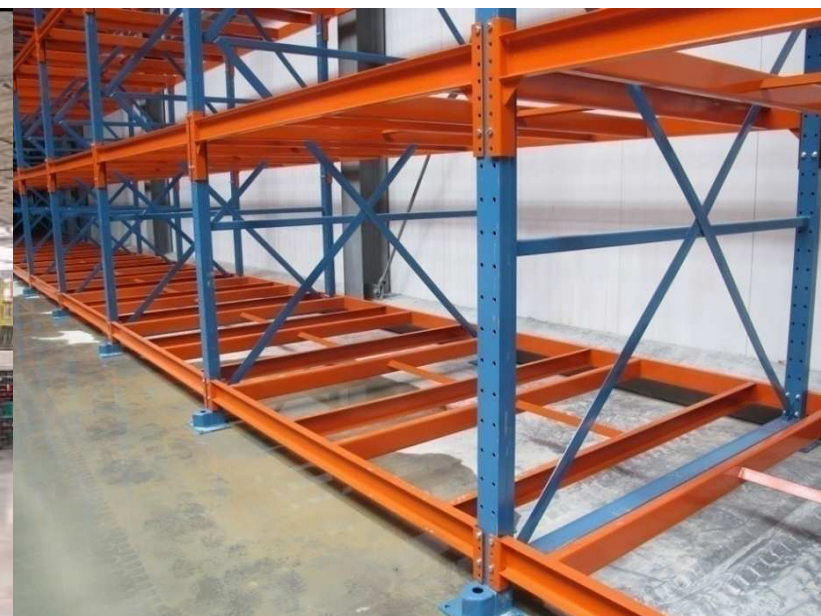

Concentrated Loads on Floor Deck

Wall Loads

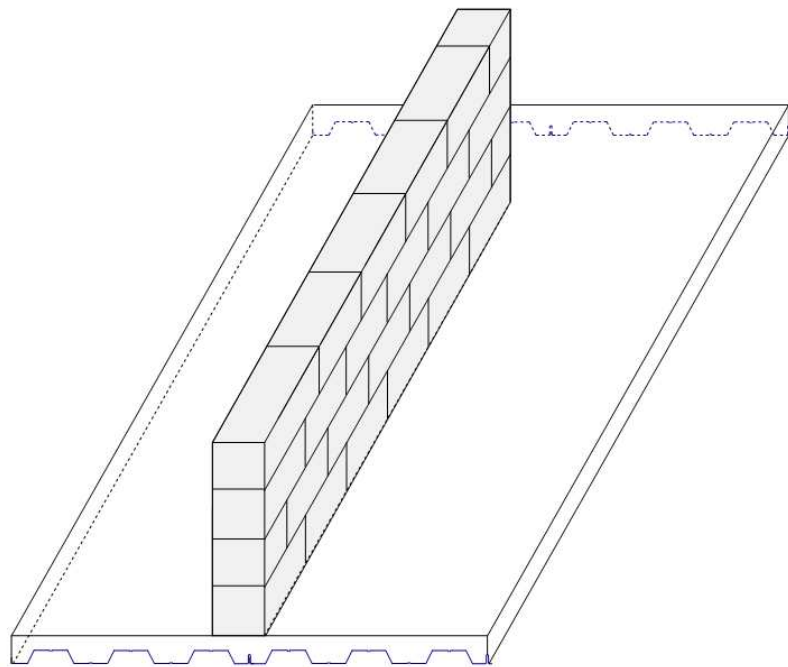

Parallel

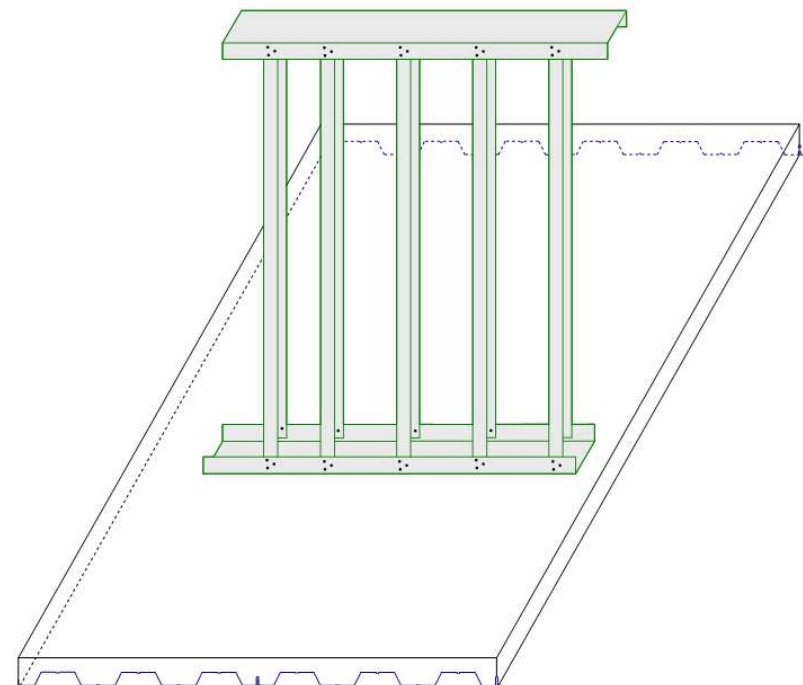

Transverse

Concentrated Loads on Floor Deck

Equipment Loads



Roof Deck Design Standard/Manual

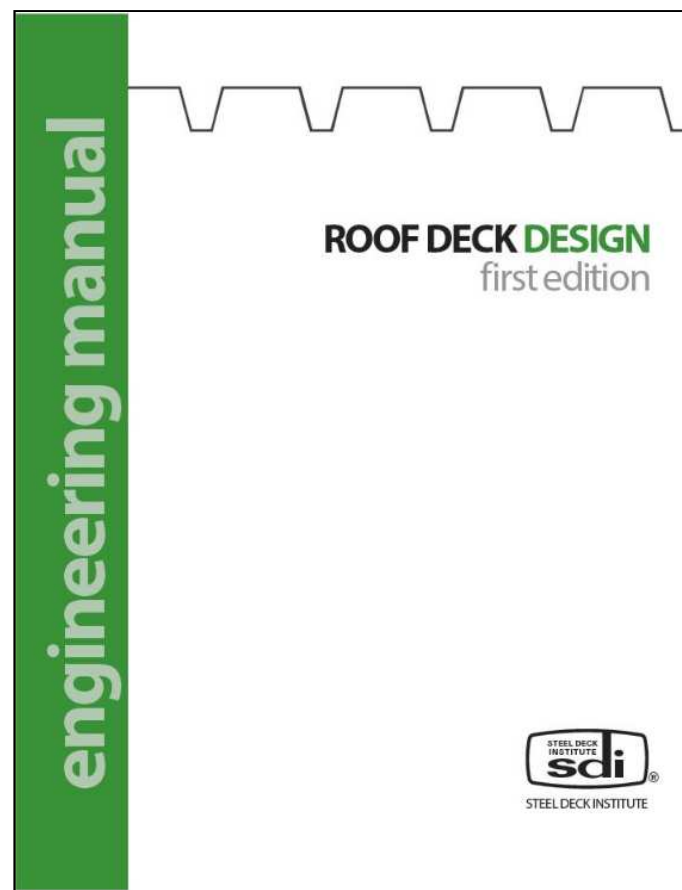
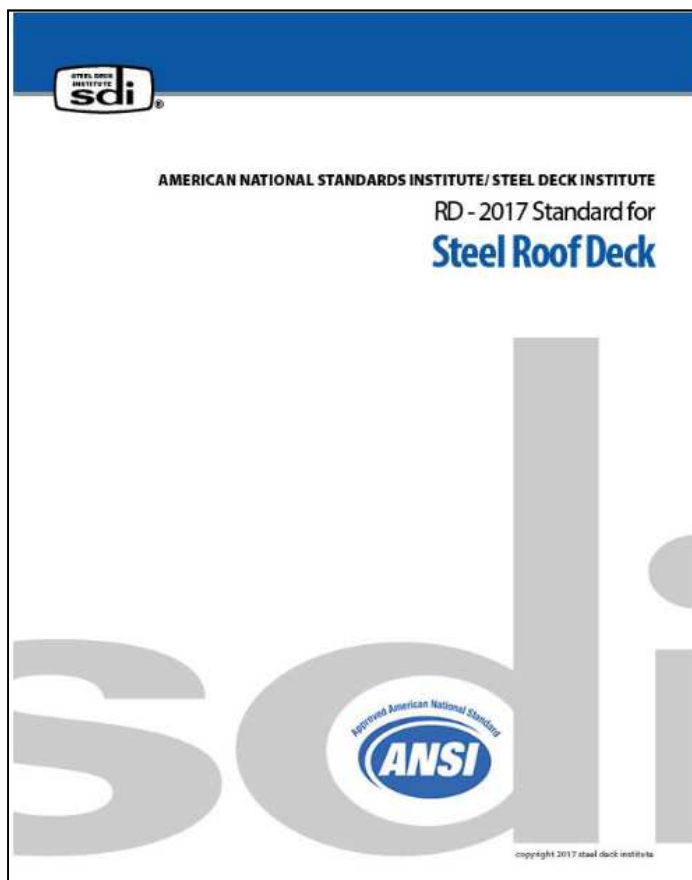

Available at www.sdi.org

Roof Deck Design Limit States

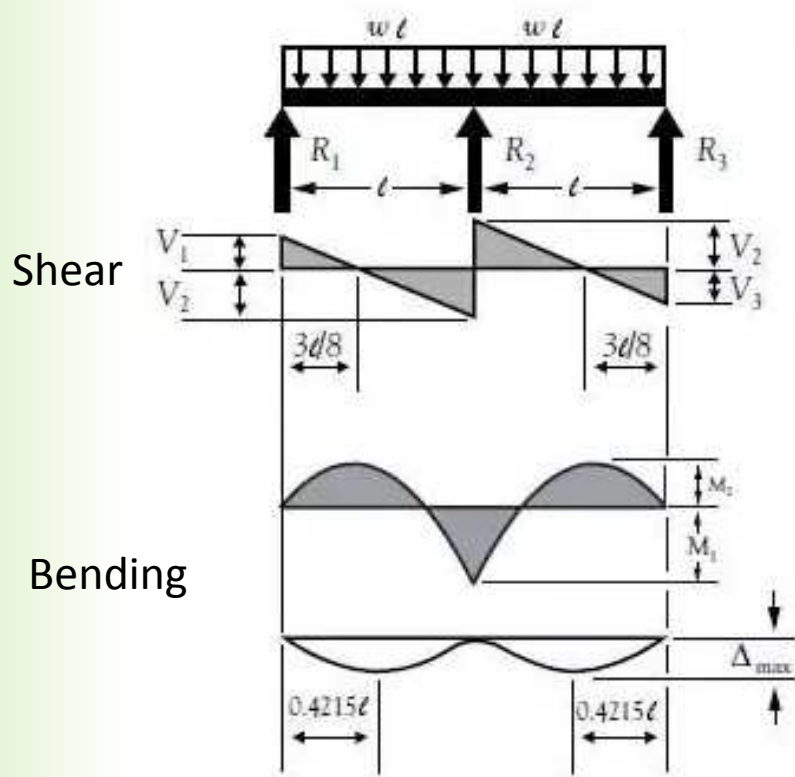

Bending/Shear Interaction



Web Crippling

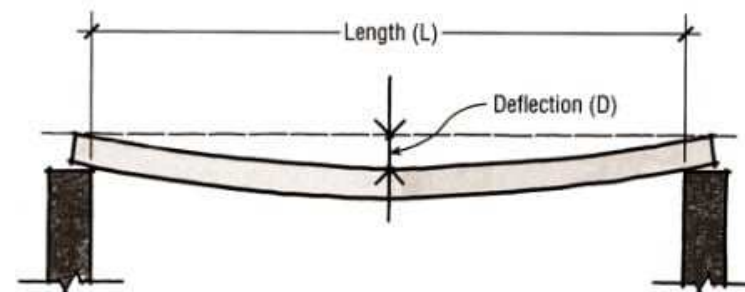

Deflection

Roof Deck – Transverse Distribution

Based on 1 ½" Deck...

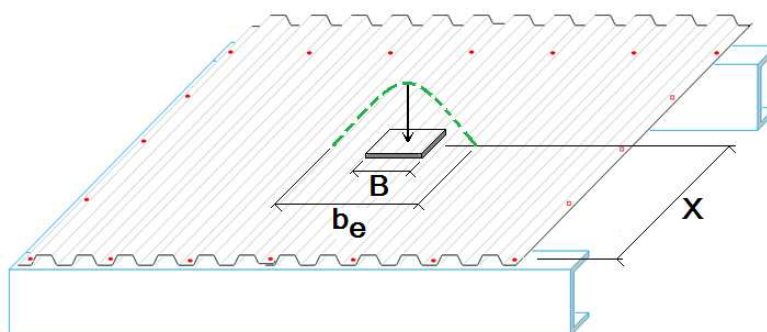

$L = \text{Span}$

$X = \% \text{ of Span}$

For $X \leq 0.25$

$$b_e = B + 6 \geq 12$$

For $0.25 < X \leq 0.50$

$$b_e = B + 18 - \frac{3}{X} \geq 24 - \frac{3}{X}$$

Where:

B = load footprint width transverse to the deck span. When the load centroid is not at the center of the footprint, let B equal twice the least dimension from the centroid to the baseplate edge; inches.

b_e = effective distribution width; inches

X = percentage of span, measured from the nearest support to the center of the concentrated load, ≤ 0.50

Roof Deck Design Example

Example 7 From RDDM...

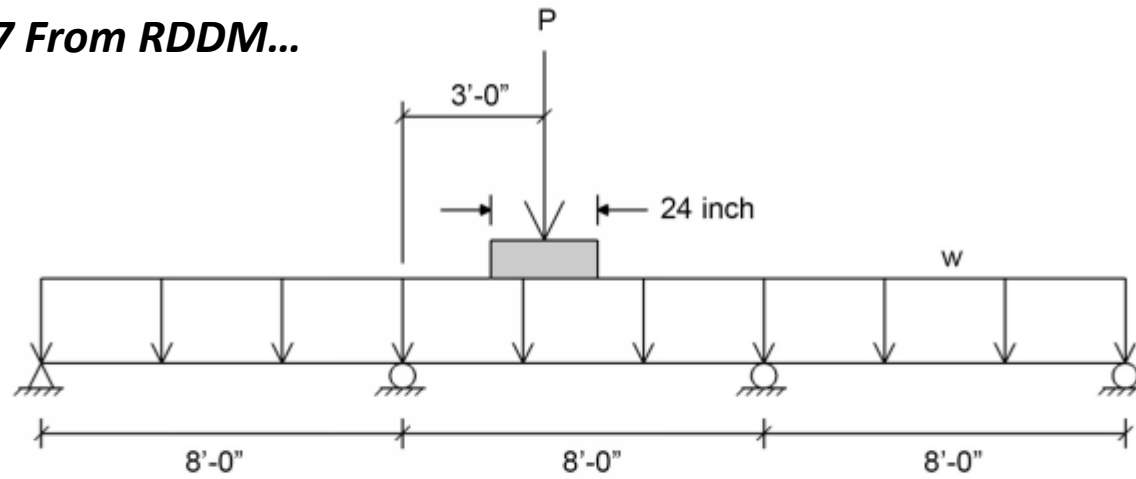

Given: Select a WR deck to support the roof load condition below. Use an ASD solution. Combine loads using ASCE 7-10.

- (1) Uniform Dead Load = 10 psf
- (2) Uniform Live Load = 20 psf
- (3) Concentrated Dead Load = 700 lbs on baseplate
 - (a) Baseplate size is 24 inches parallel to deck span and 30 inches perpendicular to deck span
 - (b) Deck End Bearing Length = 1.5 inch
 - (c) Deck Interior Bearing Length = 3 inch

Roof Deck Design Example

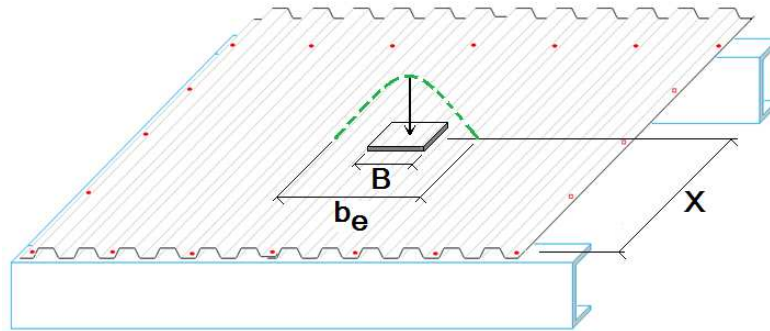

L = Span
X = % of Span

For $X \leq 0.25$

$$b_e = B + 6 \geq 12$$

For $0.25 < X \leq 0.50$

$$b_e = B + 18 - \frac{3}{X} \geq 24 - \frac{3}{X}$$

Calculate the transverse distribution of the concentrated load using the procedure found in Section 2.5.

$$L = 8 \text{ ft} \quad XL = 3 \text{ ft} \quad X = 0.375$$

$$b_e = B + 18 - \frac{3}{X} \geq 24 - \frac{3}{X}$$

$$= 30 + 18 - \frac{3}{0.375} \geq 24 - \frac{3}{0.375}$$

$$= 40 \text{ inch} \geq 16 \text{ inch}$$

Therefore the 40 inch dimension controls the transverse distribution.

Roof Deck Design Example

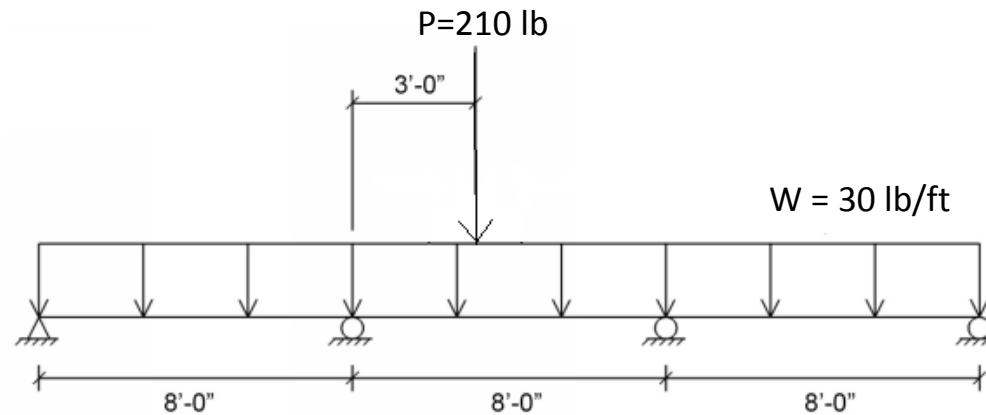

Concentrated Load is converted to a line load as $700 \text{ lbs} \times 12 / 40 = 210 \text{ plf}$.

From a structural analysis using $w = 30 \text{ plf}$ and $P = 210 \text{ lbs}$, the maximum moments and shears are found in the middle span:

$$M_n = 3918 \text{ inch-lbs at the left support}$$

$$M_p = 3632 \text{ inch-lbs under the concentrated load}$$

$$V = 255 \text{ lbs at the left support}$$

$$R_{\text{INTERIOR}} = 416 \text{ lbs at the left support (OFI)}$$

$$R_{\text{EXTERIOR}} = 83 \text{ lbs at the right support of the 3}^{\text{rd}} \text{ span (OFE)}$$

Roof Deck Design Example

Table 1 – Section Properties and Flexural Resistance

							ASD ($\Omega = 1.67$)		LRFD ($\Phi = 0.90$)	
Profile	Gage Number	Design Thickness (inches)	I_p (inch ⁴)	I_n (inch ⁴)	S_p (inch ³)	S_n (inch ³)	M_p/Ω inch-lbs	M_n/Ω inch-lbs	ΦM_p inch-lbs	ΦM_n inch-lbs
WR	22	0.0295	0.1473	0.1732	0.1713	0.1804	3385	3565	5088	5358
WR	20	0.0358	0.1910	0.2104	0.2122	0.2247	4193	4440	6302	6674
WR	18	0.0474	0.2741	0.2791	0.2883	0.2963	5697	5855	8563	8800
WR	16	0.0598	0.3528	0.3528	0.3695	0.3722	7301	7355	10974	11054

Table 6 – Shear and Web Crippling Strength

		Web Crippling									
		Shear (lbs)		ASD (lbs)				LRFD (lbs)			
Profile	Gage Number	ASD $\Omega = 1.60$	LRFD $\Phi=0.95$	$\Omega = 1.70$ OFE	$\Omega = 1.75$ OFI	$\Omega = 1.80$ TFE	$\Omega = 1.75$ TFI	$\Phi=0.90$ OFE	$\Phi=0.85$ OFI	$\Phi=0.85$ TFE	$\Phi=0.85$ TFI
NR, IR, WR	22	1325	2014	541	857	521	1057	828	1276	797	1573
NR, IR, WR	20	1588	2413	773	1248	797	1557	1183	1856	1220	2316
NR, IR, WR	18	2068	3144	1314	2171	1483	2747	2010	3229	2268	4086
NR, IR, WR	16	2523	3835	1981	3322	2374	4239	3030	4942	3632	6305
DR	22	2224	3380	366	737	321	859	559	1096	492	1278
DR	20	3123	4747	528	1067	504	1270	808	1588	771	1889
DR	18	4129	6276	910	1845	965	2247	1393	2745	1477	3342
DR	16	5115	7775	1385	2809	1574	3470	2119	4179	2409	5161

Roof Deck Design Example

Try WR20

For this condition,

$$\frac{M_n}{\Omega} = 4440 \text{ inch-lbs (Table 1)} > 3918 \text{ inch-lbs OK}$$

$$\frac{M_p}{\Omega} = 4193 \text{ inch-lbs (Table 1)} > 3632 \text{ inch-lbs OK}$$

$$V_{\text{ALLOW}} = 1588 \text{ lbs (Table 6)} > 255 \text{ lbs OK}$$

Allowable Web Crippling, (Table 6)

$$\text{OFE} = 773 \text{ lbs (1.5 inch min.)} > 83 \text{ lbs OK}$$

$$\text{OFI} = 1248 \text{ lbs (2.5 inch min.)} > 416 \text{ lbs OK}$$

Therefore,

$$\sqrt{\left(\frac{V}{V_a}\right)^2 + \left(\frac{M}{M_a}\right)^2} = \sqrt{\left(\frac{255}{1588}\right)^2 + \left(\frac{3918}{4440}\right)^2} = 0.897 \leq 1.0 \text{ OK}$$

Result:

WR20 deck is acceptable for this condition.

Floor Deck Design Standards/Manual

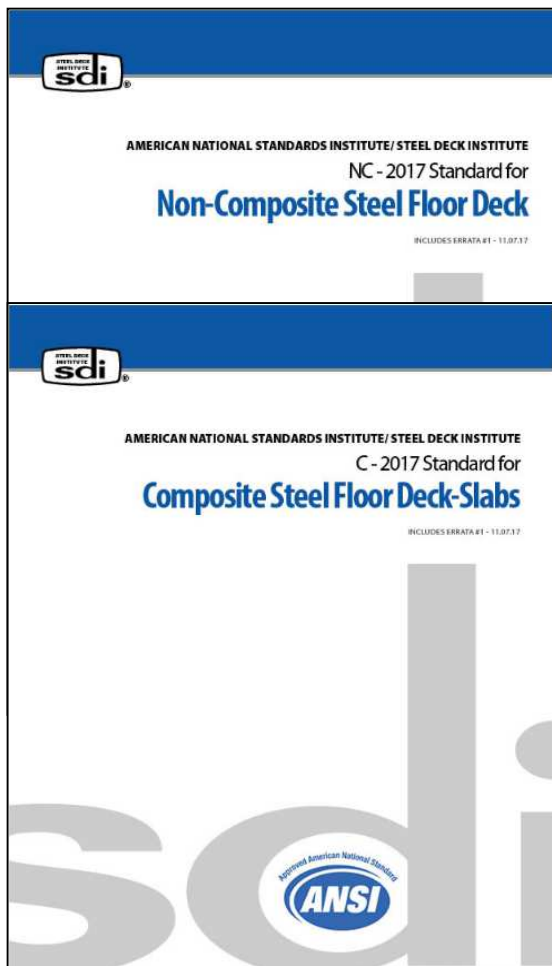

Available at www.sdi.org

Floor Deck Design Limit States

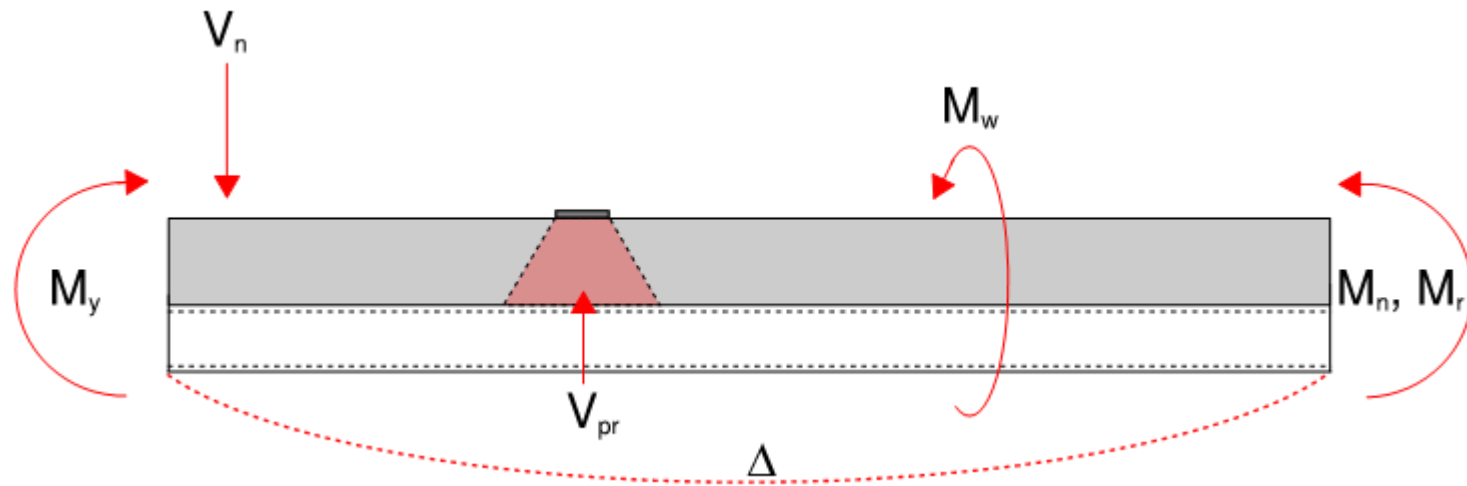

- ★ M_y Bending (+ if simple span, +/- if multiple span)
- ★ V_n One Way Beam Shear
- V_{pr} Punching Shear - unlikely to govern
- Δ Deflection - unlikely to govern
- ★ ★ M_w Transverse (Weak axis) Bending
- M_n, M_r Proprietary Deck-Slab Bending (no studs) ★

Limit States

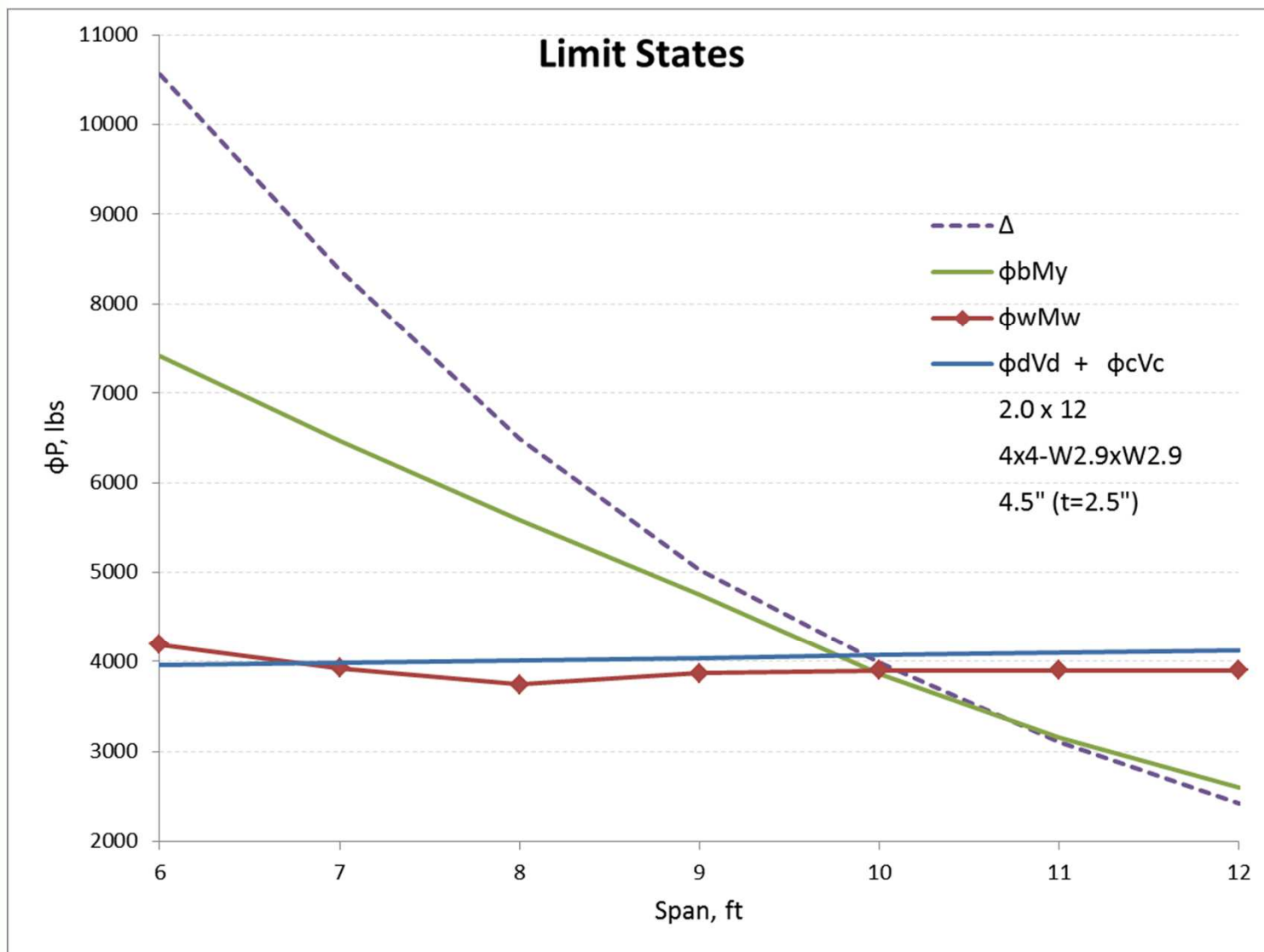

Floor Deck Load Distribution

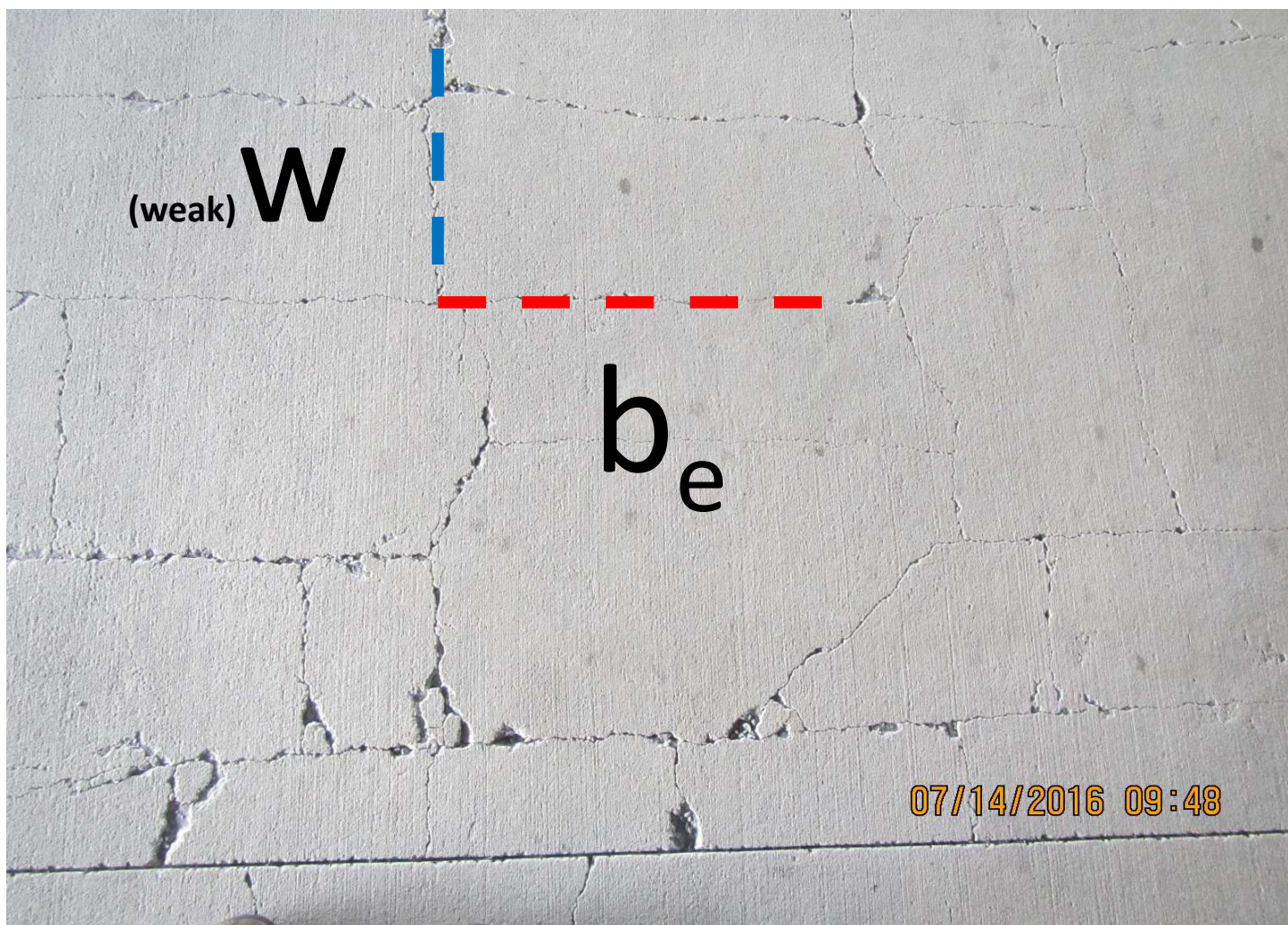

Current SDI Load Distribution

SDI FDDM/C-2017

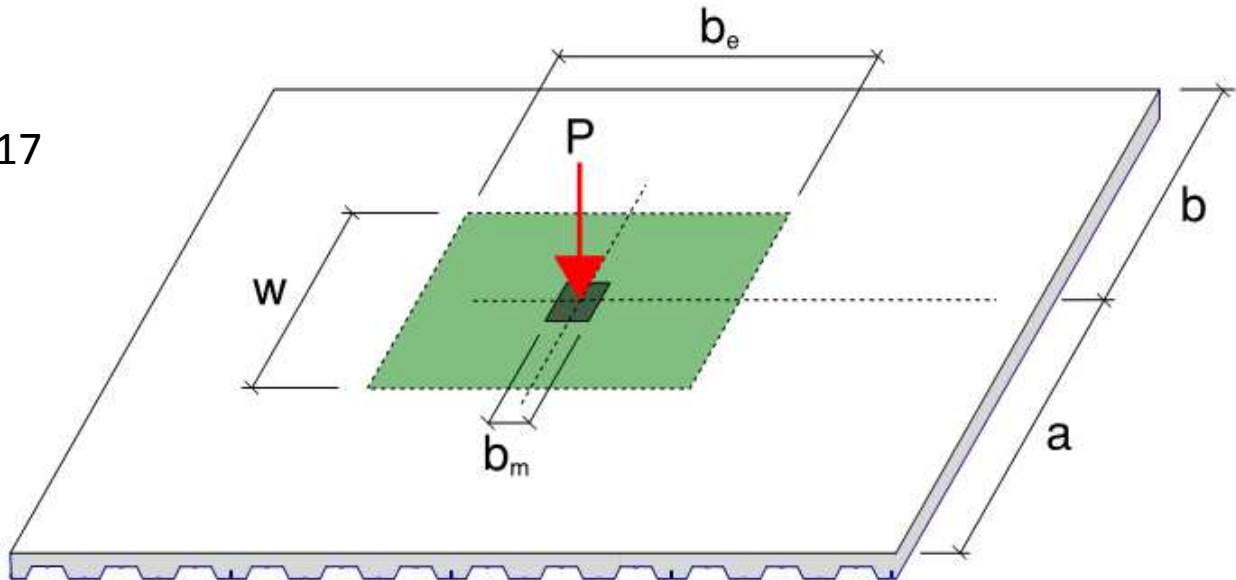

$b_m = b_2 + 2t_c + 2t_t$	Wheel/Baseplate Distribution	2.4.10
$b_e = b_m + 2 \left(1 - \frac{x}{L}\right) x$	Single Span Positive Bending	2.4.11
$b_e = b_m + \frac{4}{3} \left(1 - \frac{x}{L}\right) x$	Continuous Span Positive Bending	2.4.12
$b_{ve} = b_m + \left(1 - \frac{h}{L}\right) x$	Beam Shear	2.4.13
$w = \frac{L}{2} + b_3 < L$	Transverse Bending	2.4.14



Polling Question #1

Which Limit State is NOT Applicable for Designing Concentrated Loads on Concrete Slabs on FLOOR Deck?

- a) Weak Axis Bending
- b) Web Crippling
- c) Punching Shear
- d) Positive Bending
- e) Negative Bending

Can We Solve This Load Diagram?

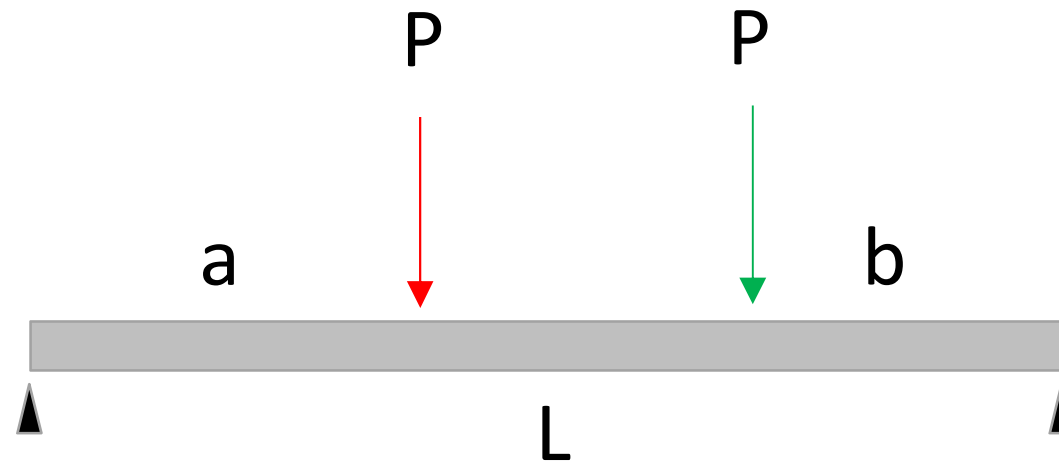

Cluster (multiple) loads.
Simple beam loading diagram.
Known engineering mechanics.

- Shear
- Bending
- Deflection

Use traditional engineering mechanics to solve complex cluster analysis.

Cluster Loads

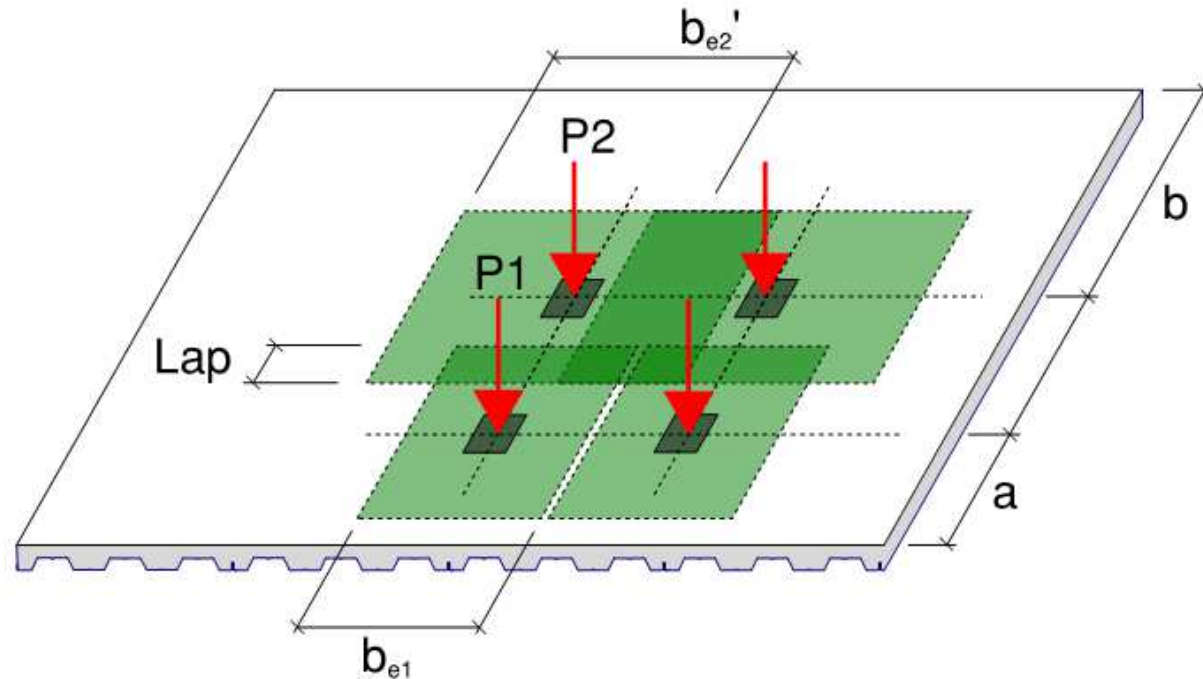

NEW

<i>Adjacent Loads,</i>	M_y, V_n, Δ	$b'_e = \frac{b_e + \text{Adjacent load spacing}}{2} \leq b_e$
<i>In - Line Loads,</i>	M_w	$M_w = \left(\frac{P}{w} + \frac{P(\text{Lap})}{w^2} \right) \frac{12 b_e}{15}$
<i>Adjacent Loads,</i>	M_x	$M_x = 5.5 M_1 \left[\frac{x}{b_e} - \frac{1}{\pi} \sin \left(\frac{\pi x}{b_e} \right) \right] \text{ rad}$

2 Loads “In-Line”

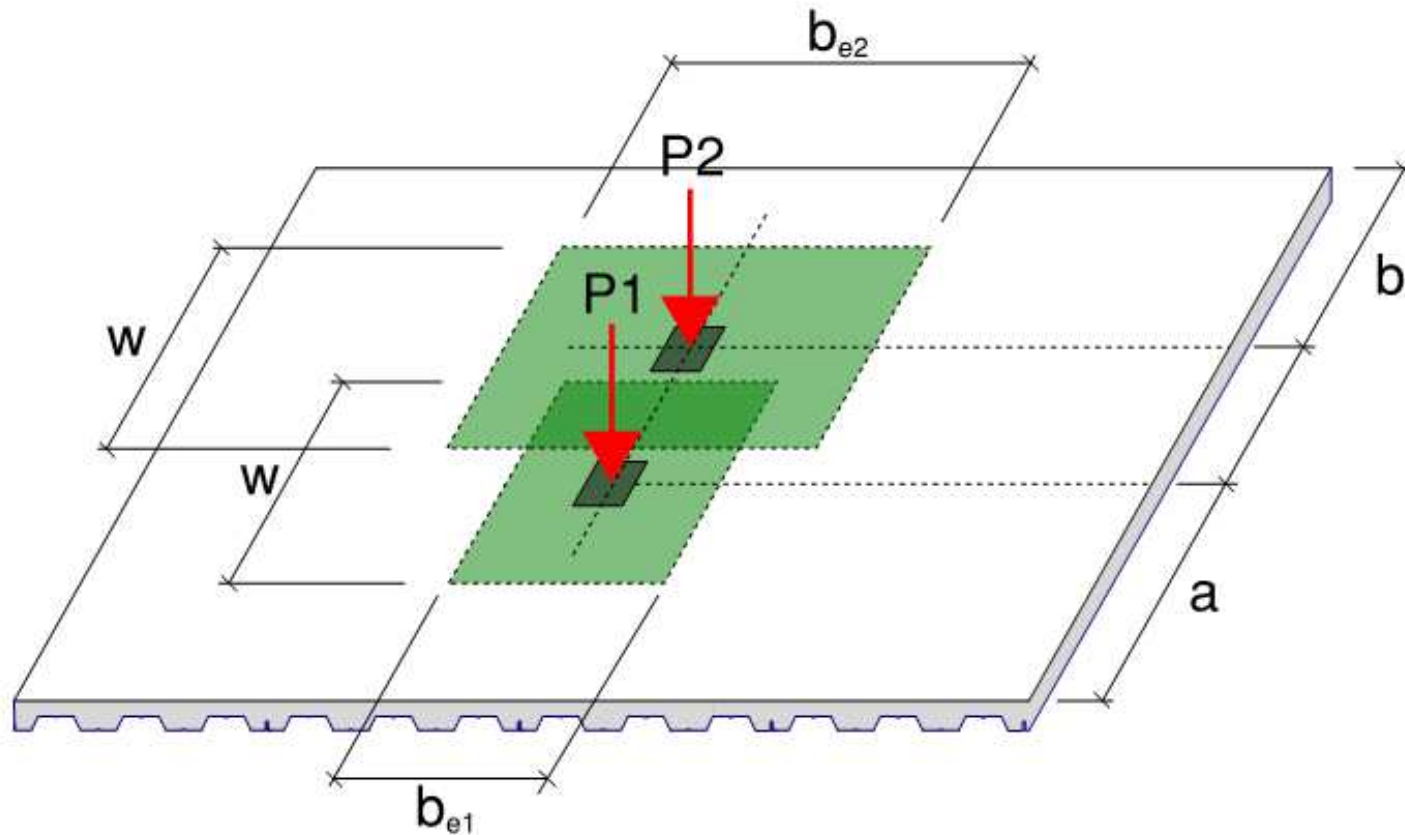

In-line loads act simultaneously on a 1' effective width.

Use P/b_e model and simple span beam for M_y, V_n, Δ .

Use **New** “Lap” equation for M_w .

2 Loads “In-Line”, M_y, V_n, Δ

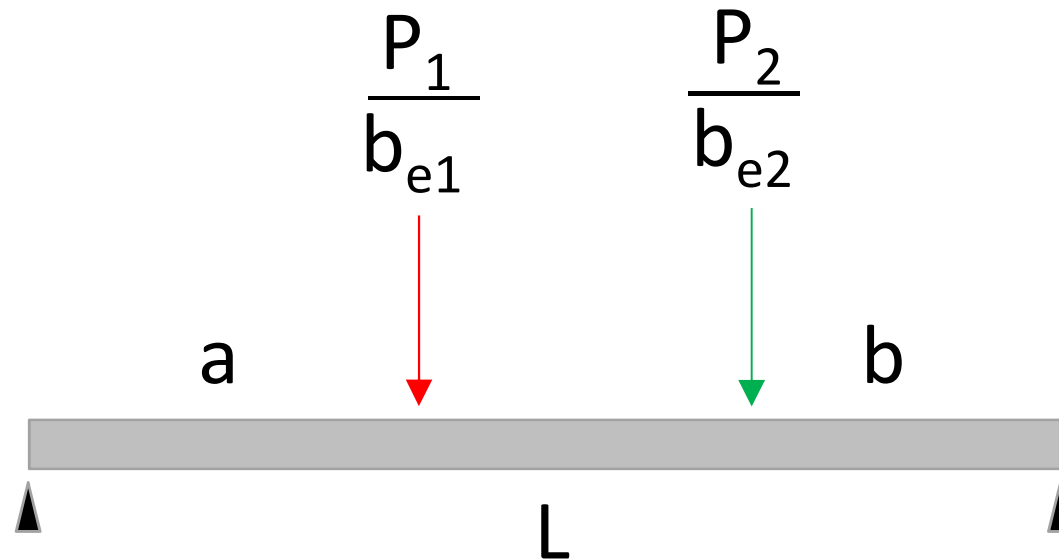

Distribute loads using associated effective widths, b_{e1} and b_{e2} .

P_1 and P_2 are typically equal, but P/b_e ratios differ.

Simple beam analysis for M_y, V_n, Δ .

Solve for desired variable; a, b, L, P .

2 Loads "In-Line", M_y

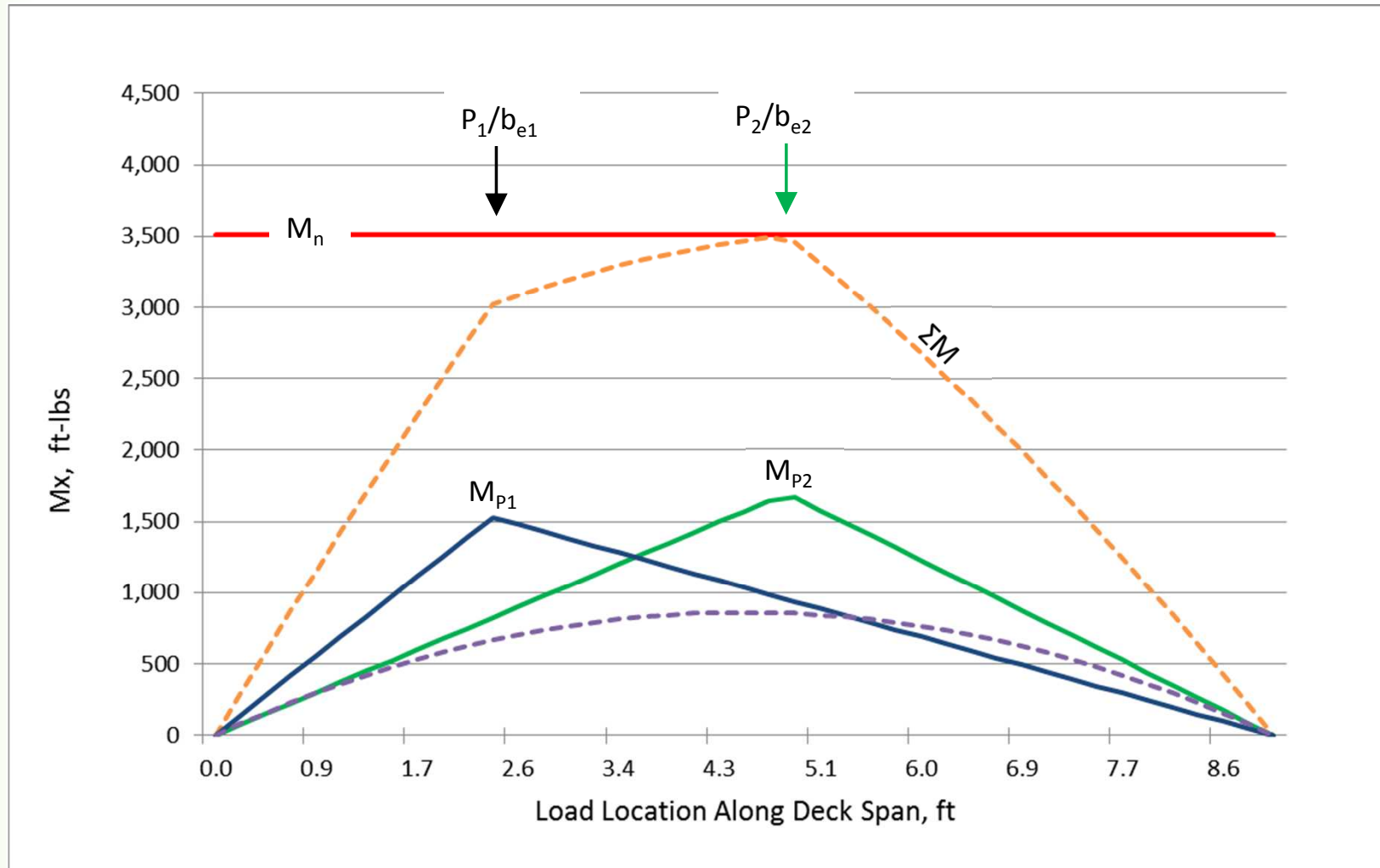

2 Loads "In-Line", V_n

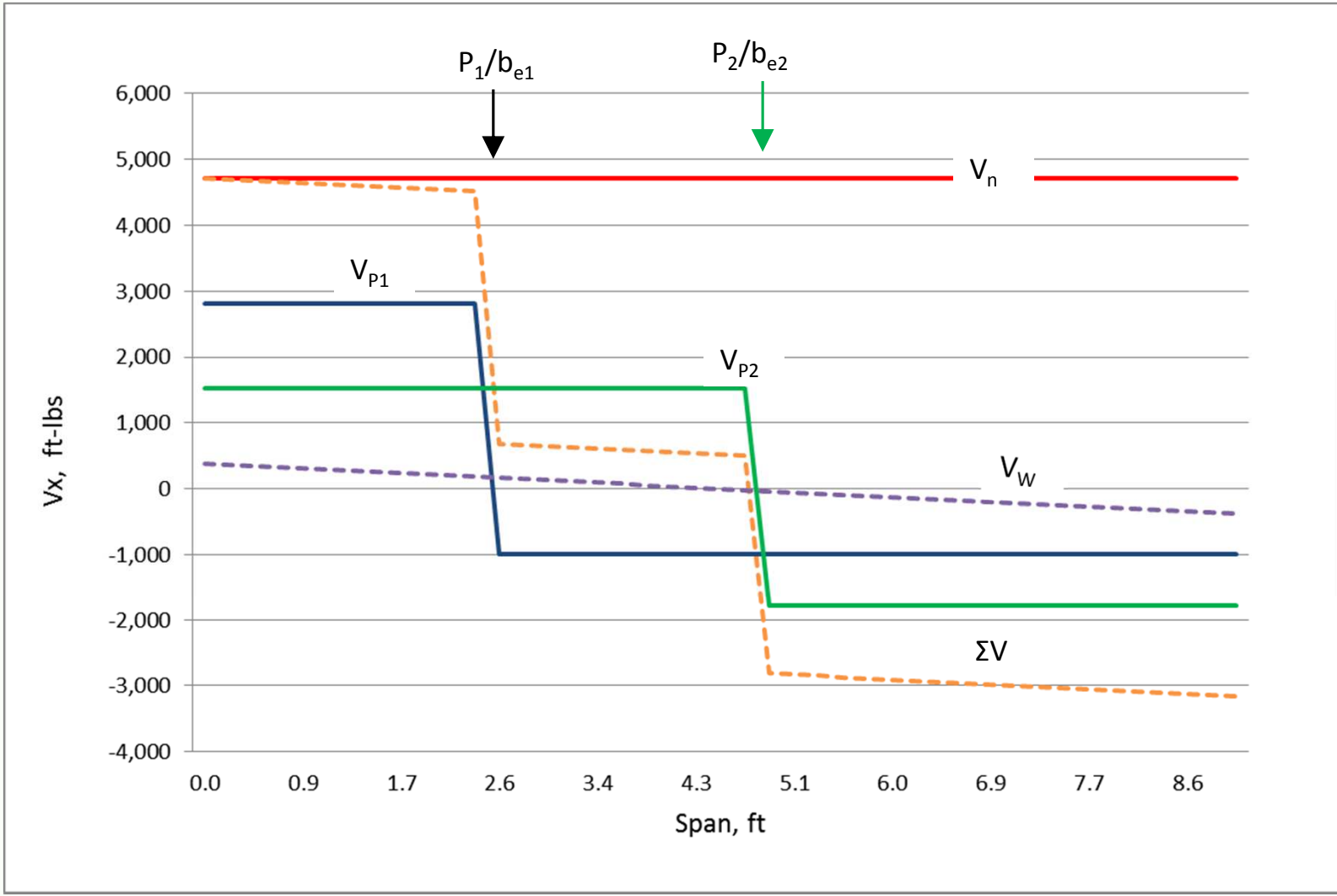

2 Loads “In-Line”, M_w

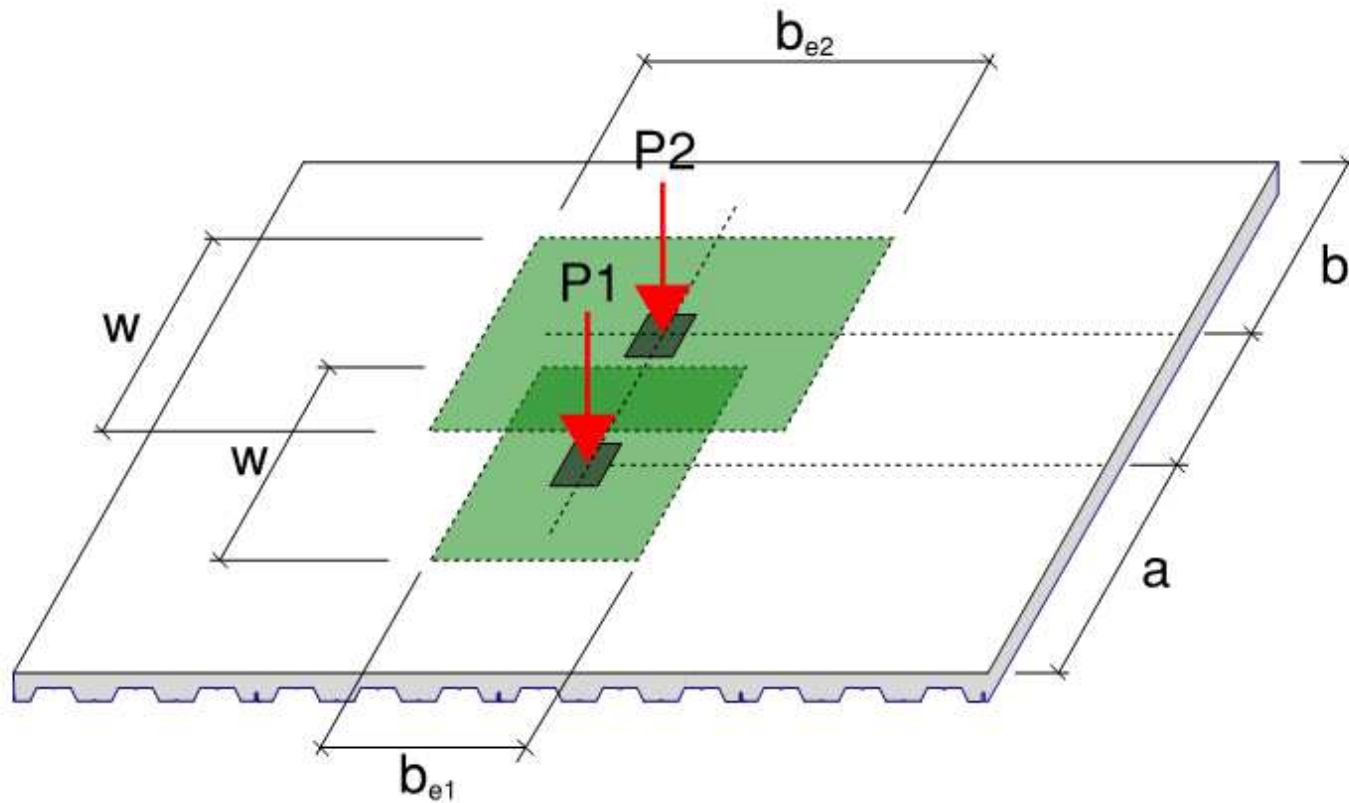

Do influence zones overlap?

- If no, use existing SDI procedures for a single concentrated load.
- If yes, use **new** “Lap” equation to correct for “w” overlap.

2 Loads “In-Line”, M_w

$$\Phi_w M_w = \frac{FP b_e 12}{w 15}$$

NEW

$$\Phi_w M_w = \frac{2FP b_e 12}{w 15}$$

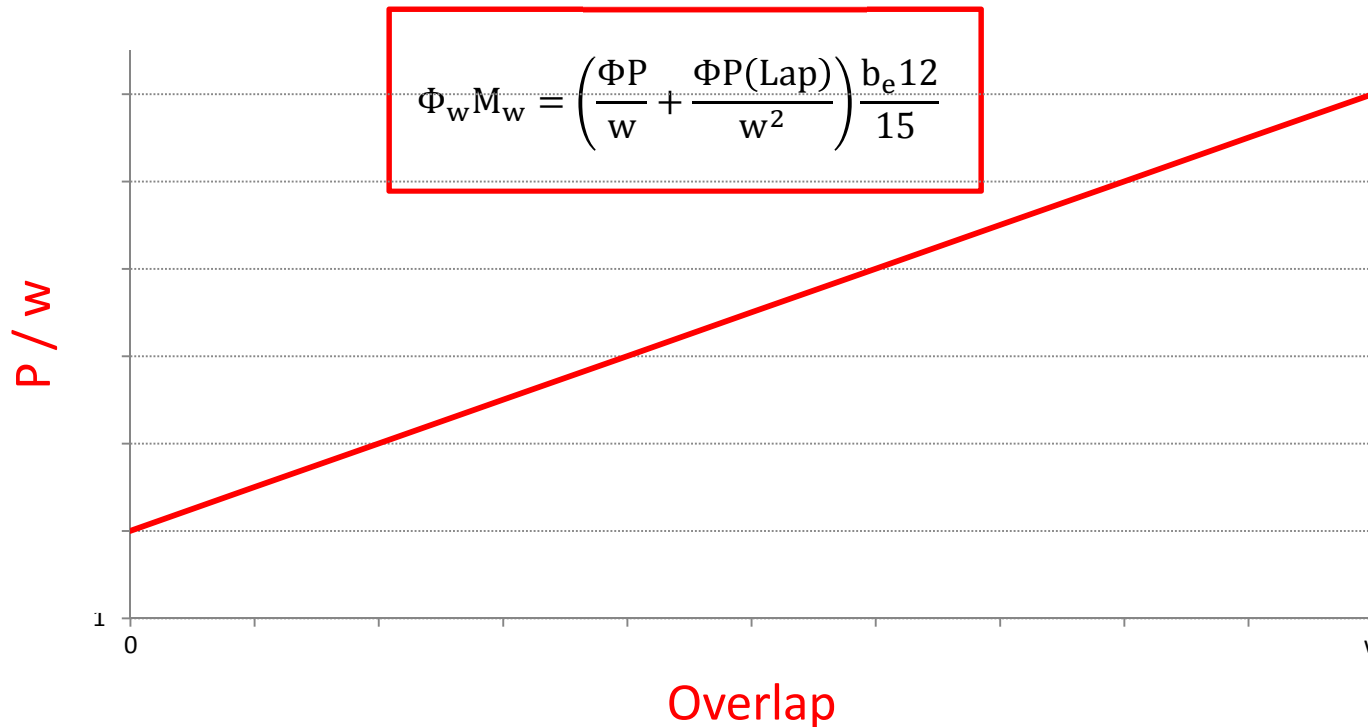

The great advantage to this equation is “***IT WORKS EVERYWHERE***”
regardless of the overlap. $\phi_w = 0.75$, $\Omega_w = 2.0$

2 Loads “In-Line”, Scaffold

LAP = 2.33' (use 2.0')

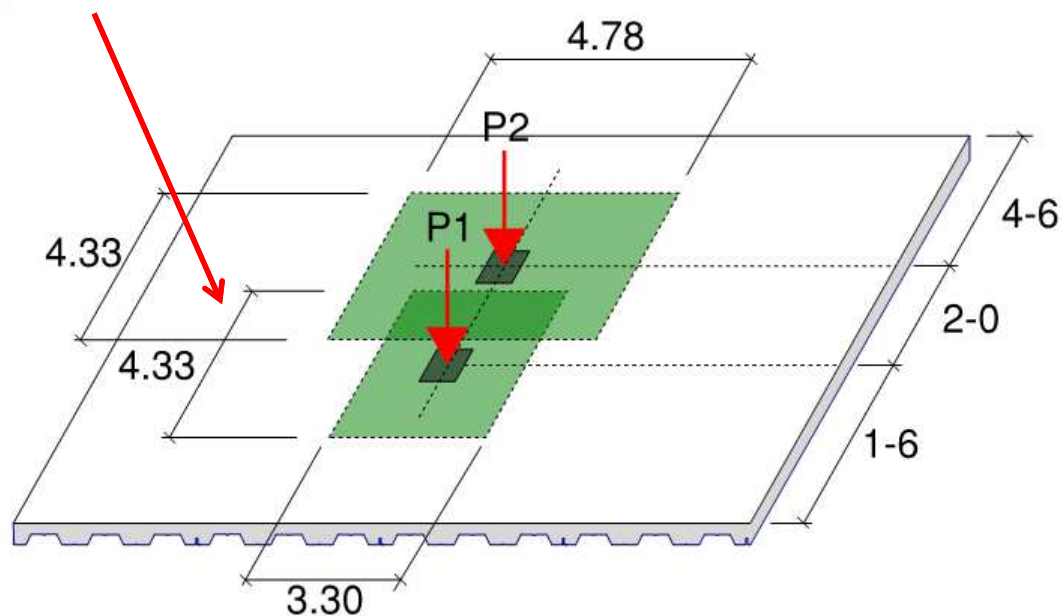

- 2 x 12 x 20
- 8-0 span
- 5" NW slab (t = 3")
- W6xW6-W2.1xW2.1
- d = 1.5"
- Scaffold post, b = 4"
- $W_L = 0$
- $W_d = (1.2) 52 \text{ psf}$
- $\phi M_y = 4140 \text{ ft-lbs/ft}$
- $\phi V_n = 5116 \text{ lb/ft}$
- **$\phi_w M_w = 2757 \text{ in-lb/ft}$**

Typical slab capacities for bending and shear from SDI FDDM.

Weak axis bending capacity, 2757 in-lb/ft, calculated.

Why is LRFD desirable?

2 Loads “In-Line”, Scaffold, M_y, V_n, Δ

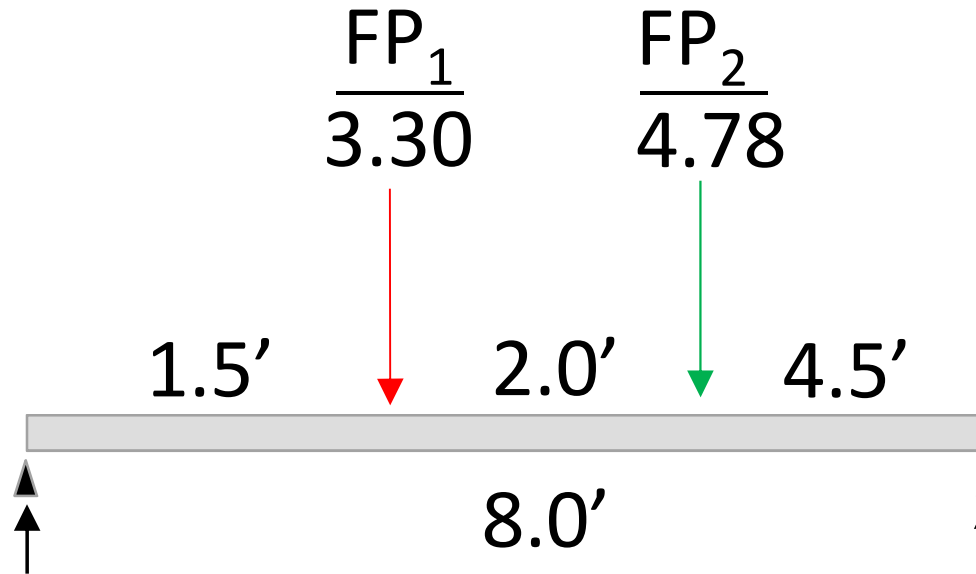

$$R_R = 5116 = \frac{62(8)}{2} + \frac{FP}{3.3} \left(\frac{1.5}{8} \right) + \frac{FP}{4.78} \left(\frac{3.5}{8} \right)$$

- $FP = 33822$ lbs

$$R_L = 5116 = \frac{62(8)}{2} + \frac{FP}{3.3} \left(\frac{6.5}{8} \right) + \frac{FP}{4.78} \left(\frac{4.5}{8} \right)$$

- $FP = 13377$ lbs

$$M_{@P1} = 4140 = \frac{62(1.5)(6.5)}{2} + \frac{FP(1.5)(6.5)}{(3.30)8} + \frac{FP(4.5)(1.5)}{(4.78)8}$$

- $FP = 7029$ lbs

$$M_{@P2} = 4140 = \frac{62(3.5)(4.5)}{2} + \frac{FP(1.5)(4.5)}{(3.30)8} + \frac{FP(3.5)(4.5)}{(4.78)8}$$

- $FP = 5470$ lbs

2 Loads “In-Line”, Scaffold, M_w

$$\frac{FP}{w} = \frac{FP}{4.33}$$

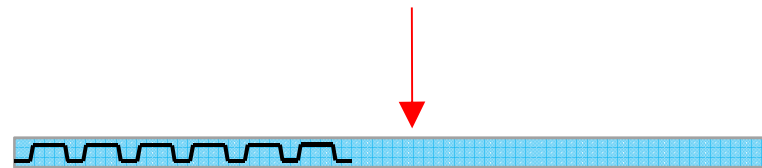

$$b_{e \max} = 4.78'$$

1. Distribute P over an effective width “w”, not “ b_e ”.
2. The weak axis beam length = b_e and will differ for P_1 and P_2 . Use $b_{e \max}$
3. Use the **new** ϕM_w to correct for influence zone overlap.
4. Use $\phi_w = 0.75$ and $\Omega_w = 2.0$ (not ACI factors)

$$\Phi M_w = \left(\frac{FP}{w} + \frac{FP(Lap)}{w^2} \right) \frac{b_e 12}{15}$$

$$M_{w@P2} = 2757 = \left(\frac{12FP}{4.33} + \frac{12FP(2.0)}{4.33^2} \right) \left(\frac{4.78}{15} \right)$$

• $FP = 2135$ lbs

2 Loads “Adjacent”

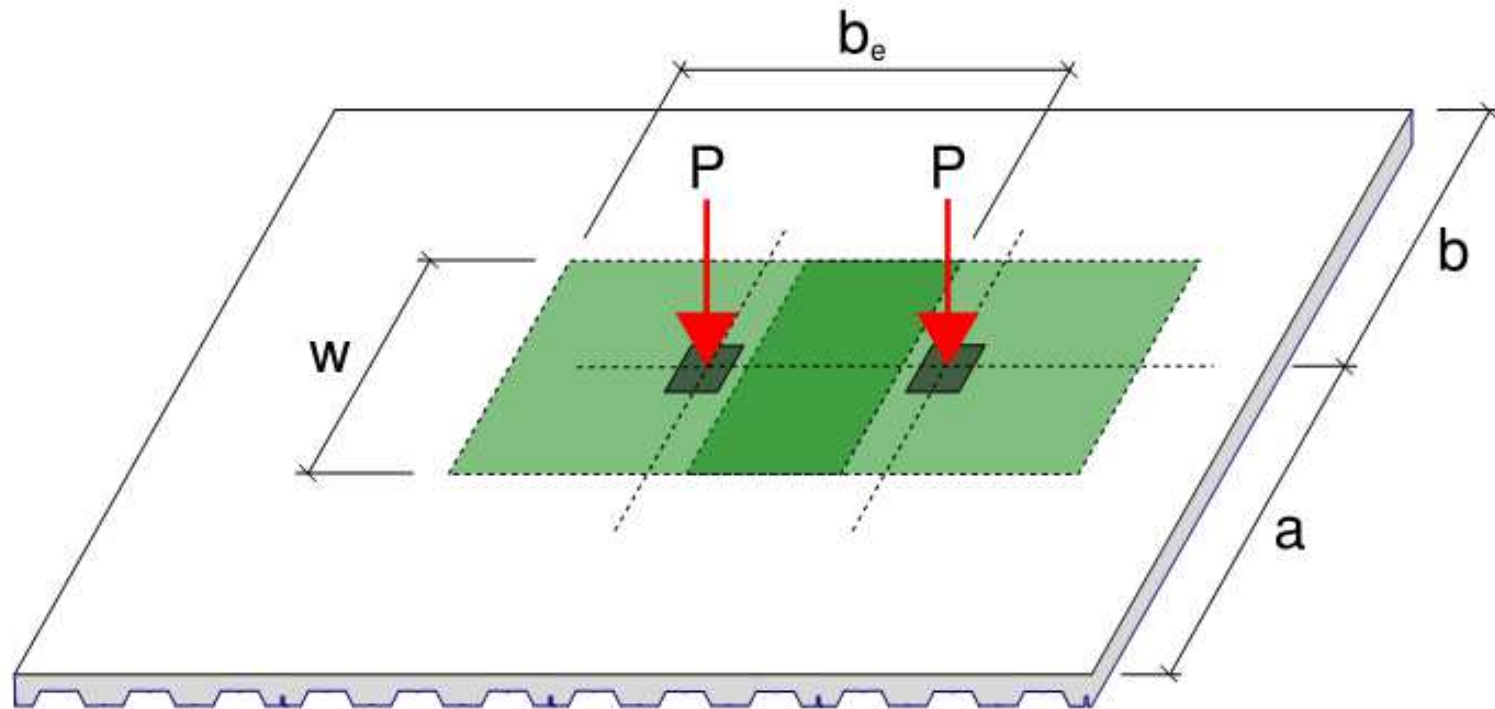

Do influence zones overlap?

- If no, use existing SDI procedures for a single concentrated load.
- If yes, use **New** P/b_e' model for $M_y, V_n, \Delta \dots$ “*don't use concrete twice*”.
- If yes, use **New** M_x sin equation with M_w .

2 Loads “Adjacent”, M_y, V_n, Δ

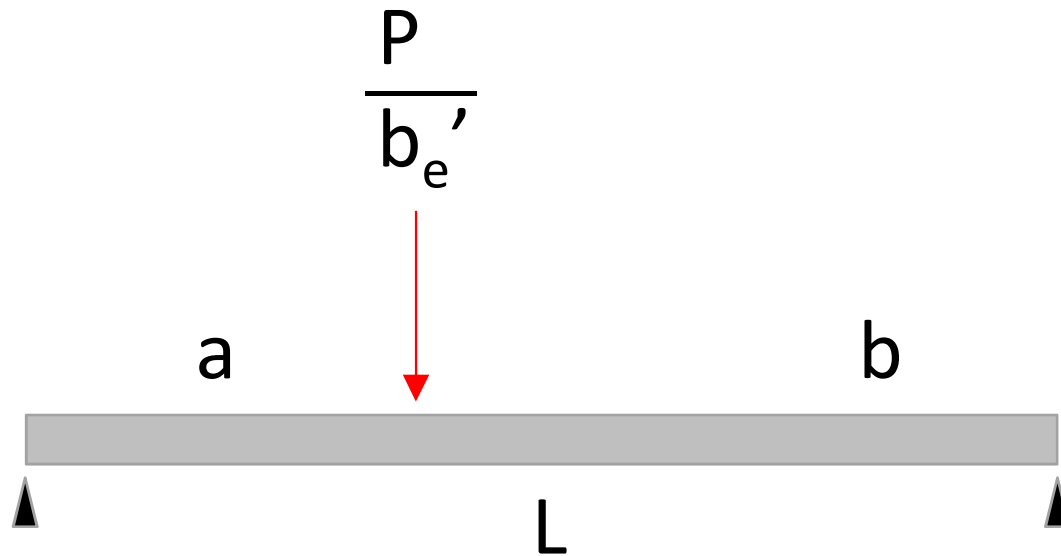

$$b_e' = \frac{b_e + \text{Adjacent load spacing}}{2} \leq b_e$$

NEW

2 Loads “Adjacent”, M_w

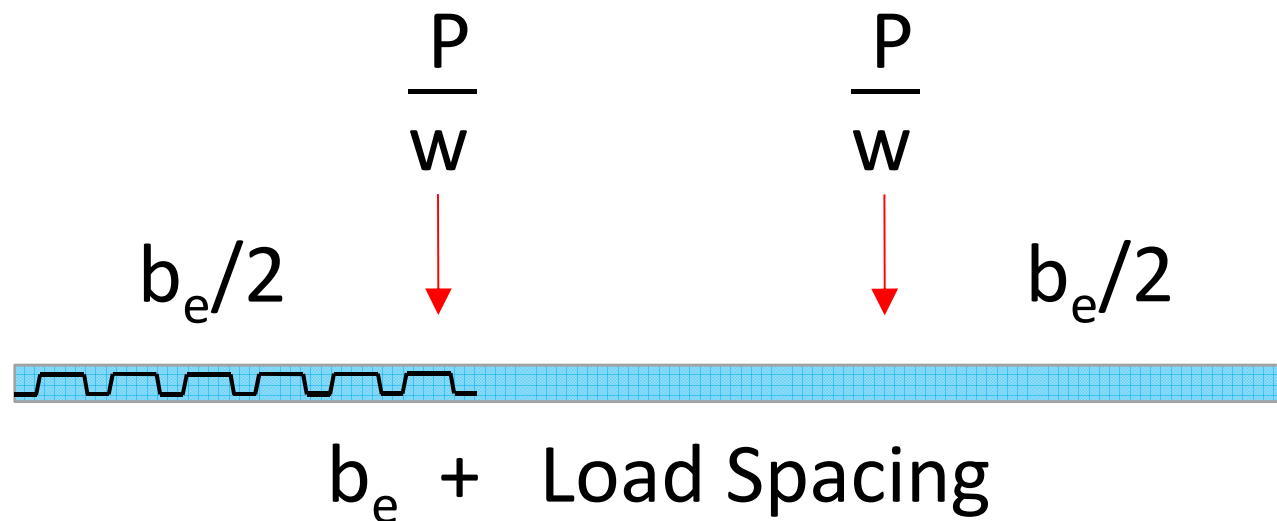

Overlapping adjacent influence zones may result in **cumulative** weak axis bending moments, and traditional SDI mechanics may not be appropriate for a two-way slab problem with sinusoidal stress distribution.

To demonstrate, the next 3 slides show the effects of load spacing and superposition.

2 Loads “Adjacent”, M_w

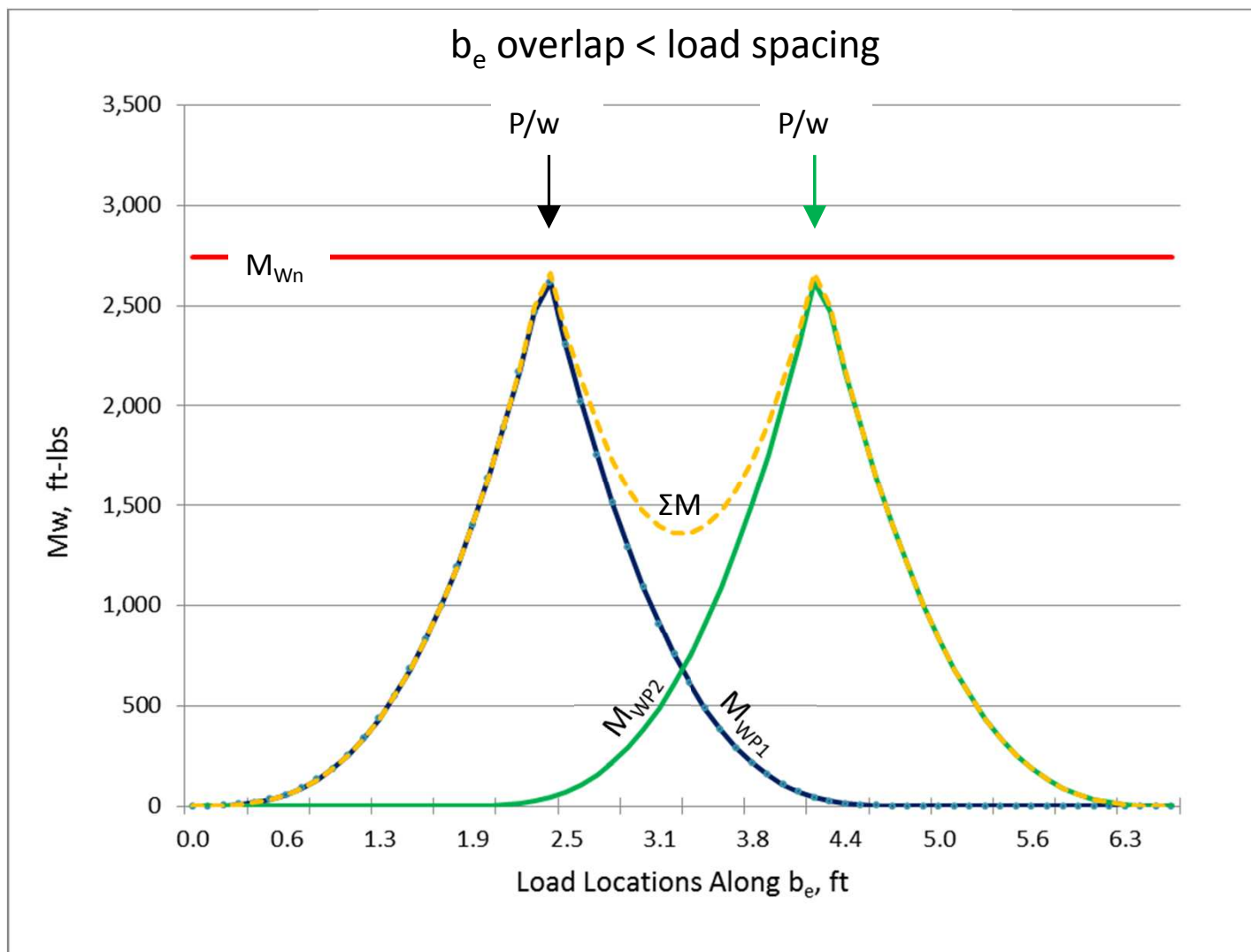

2 Loads “Adjacent”, M_w

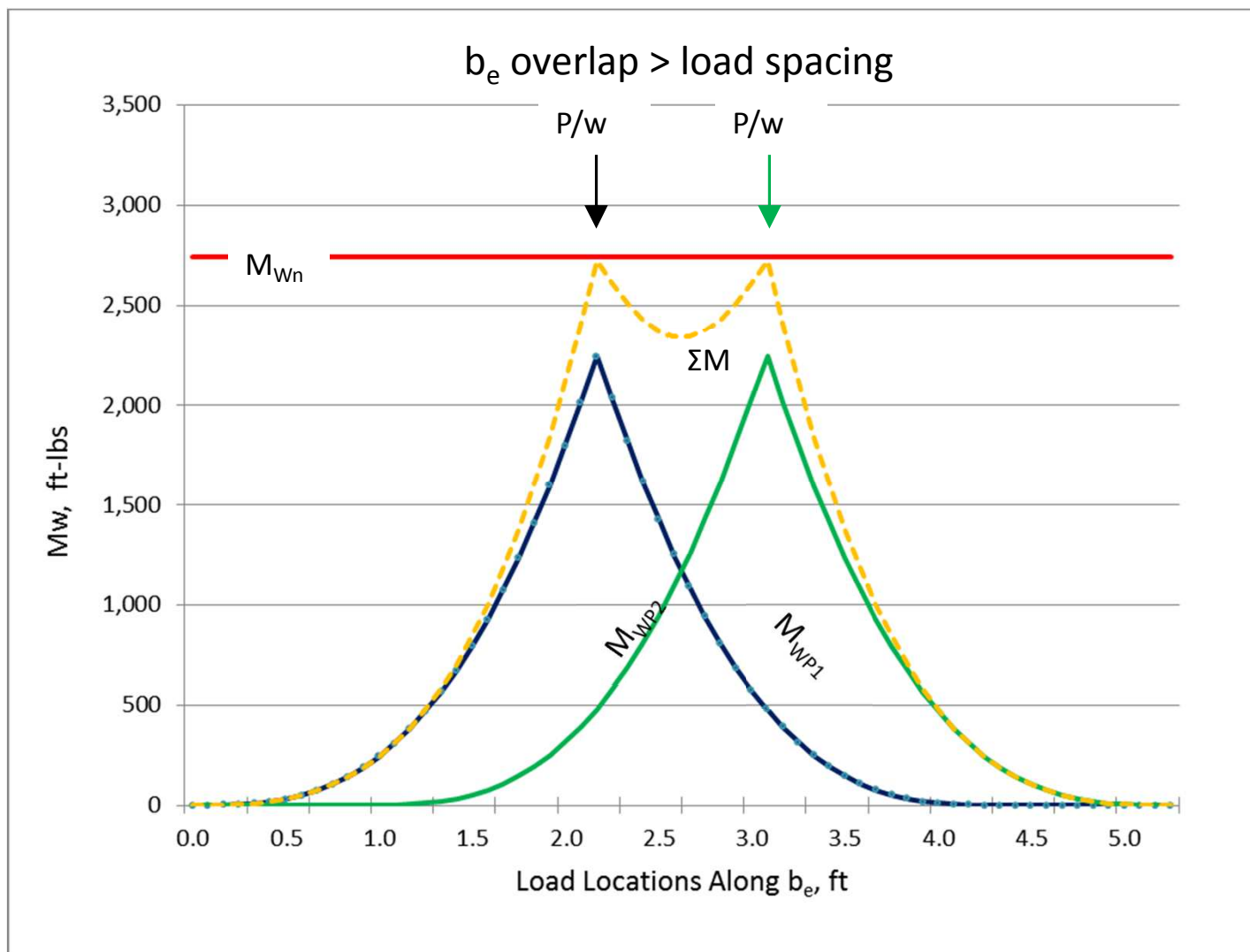

2 Loads “Adjacent”, M_w

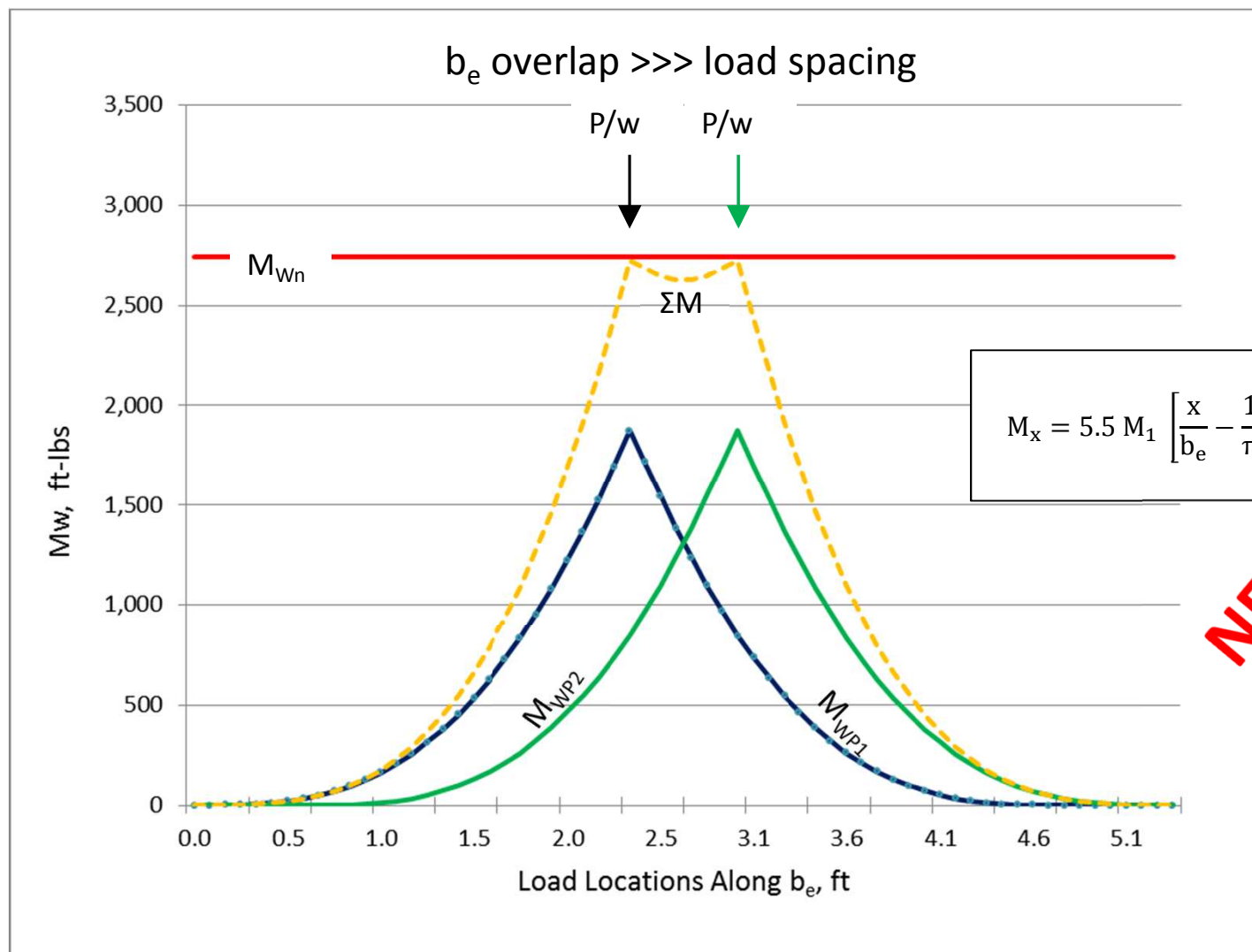

NEW



2 Loads “Adjacent”, Scaffold

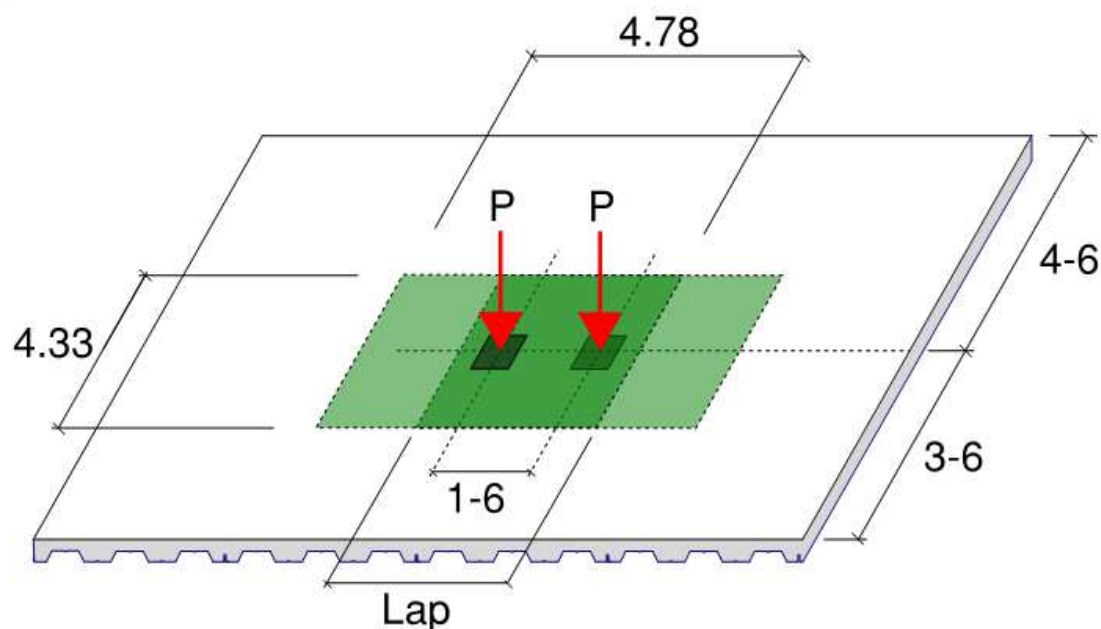

- 2 x 12 x 20
- 8-0 span
- 5" NW slab (t = 3")
- W6xW6-W2.1xW2.1
- d = 1.5"
- Scaffold post, b = 4"

- $W_L = 0$
- $W_d = (1.2) 52 \text{ psf}$
- $\phi M_y = 4140 \text{ ft-lbs/ft}$
- $\phi V_n = 5116 \text{ lb/ft}$
- $\phi M_w = 2757 \text{ in-lb/ft}$

$$b'_e = \left(\frac{b_e + \text{load spacing}}{2} \right) = \left(\frac{4.78 + 1.5}{2} \right) = 3.14 \text{ ft}$$

NEW

2 Loads “Adjacent”, Scaffold M_y, V_n, Δ

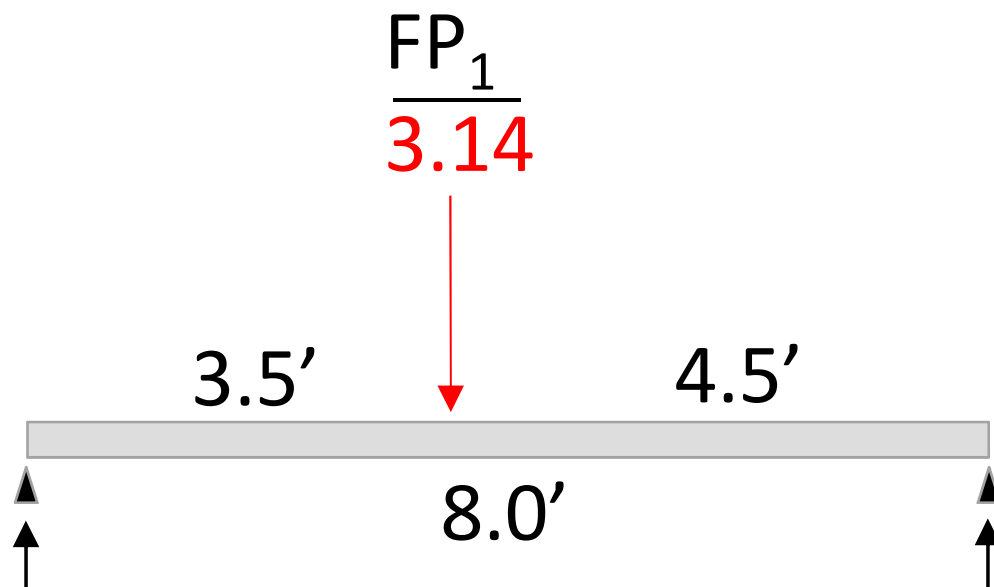

- $b_e = 4.78$ ft
- $b_e' = 3.14$ ft
- $W = 4.33$ ft
- $W_d = 62$ psf

$$R_R = 5116 \text{ lbs} = \frac{62 \text{ plf}(8 \text{ ft})}{2} + \frac{\text{FP}}{3.14 \text{ ft}} \left(\frac{3.5 \text{ ft}}{8 \text{ ft}} \right)$$

- $\text{FP} = 34938$ lbs

$$R_L = 5116 \text{ lbs} = \frac{62 \text{ plf}(8 \text{ ft})}{2} + \frac{\text{FP}}{3.14 \text{ ft}} \left(\frac{4.5 \text{ ft}}{8 \text{ ft}} \right)$$

- $\text{FP} = 27174$ lbs

$$M_{@P} = 4140 \frac{\text{ft} - \text{lbs}}{\text{ft}} = \frac{62 \text{ plf} (3.5 \text{ ft})(4.5 \text{ ft})}{2} + \frac{\text{FP}(4.5 \text{ ft})(3.5 \text{ ft})}{(3.14 \text{ ft})8 \text{ ft}}$$

- $\text{FP} = 5824$ lbs

2 Loads “Adjacent”, Scaffold M_w

$$\Phi M_1 = \frac{12FP}{w} \left(\frac{b_e}{15} \right)$$

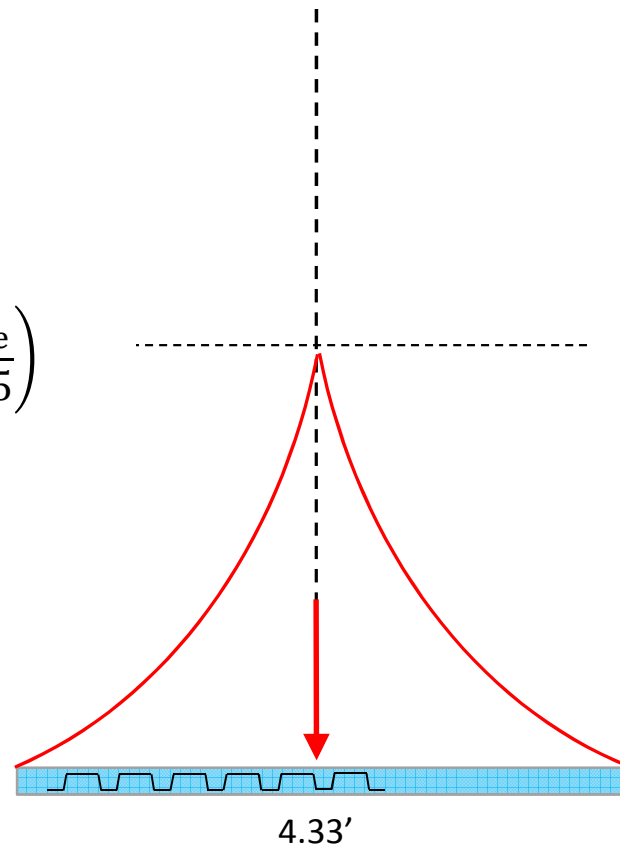

Load P develops a sinusoidal moment envelope over a beam length = b_e resisted by the available weak axis bending moment = ΦM_w and $\Phi M_w < \Phi M_n$

2 Loads “Adjacent”, Scaffold M_w

$$\Phi M_1 = \frac{12FP}{w} \left(\frac{b_e}{15} \right)$$

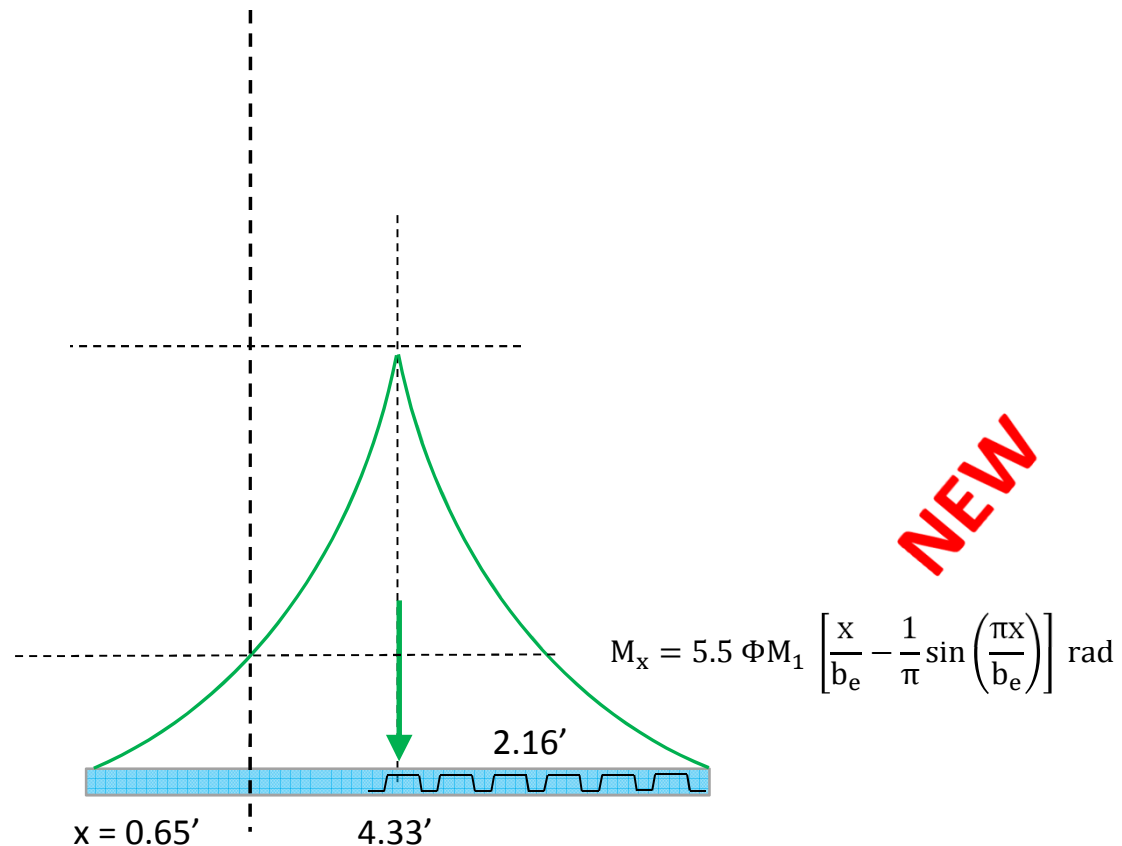

The adjacent load P develops a similar moment curve. In this example, we are interested in the weak axis moment at $x = 0.65'$.

2 Loads “Adjacent”, Scaffold M_w

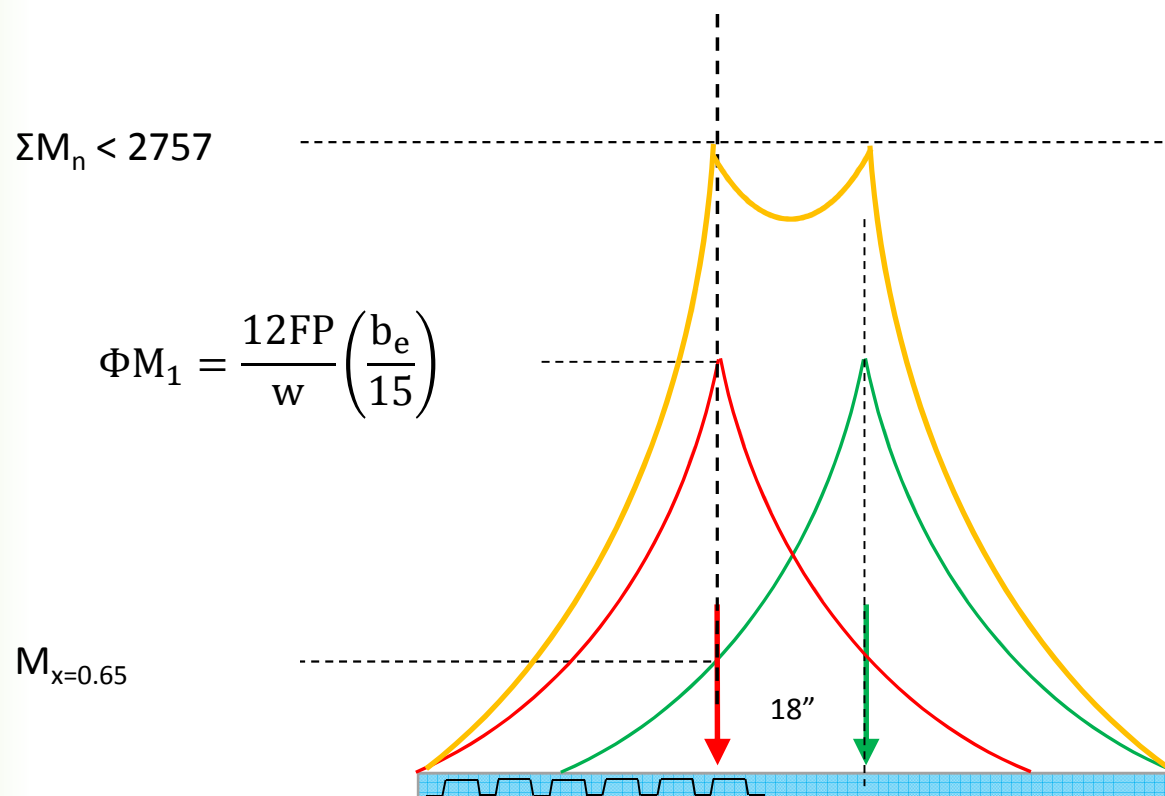

Focus on the picture, not the equation.

$$2757 \frac{\text{in} - \text{lbs}}{\text{ft}} = \frac{12FP}{4.33 \text{ ft}} \left(\frac{4.78 \text{ ft}}{15} \right) + 5.5 \left[\frac{12\Phi P}{4.33 \text{ ft}} \left(\frac{4.78 \text{ ft}}{15} \right) \right] \left[\frac{0.65 \text{ ft}}{4.78 \text{ ft}} - \frac{1}{\pi} \sin \left(\frac{\pi(0.65 \text{ ft})}{4.78 \text{ ft}} \right) \right] \text{ rad}$$

$$FP = 2977 \text{ lbs}$$

4 Loads “In-Line” and “Adjacent”

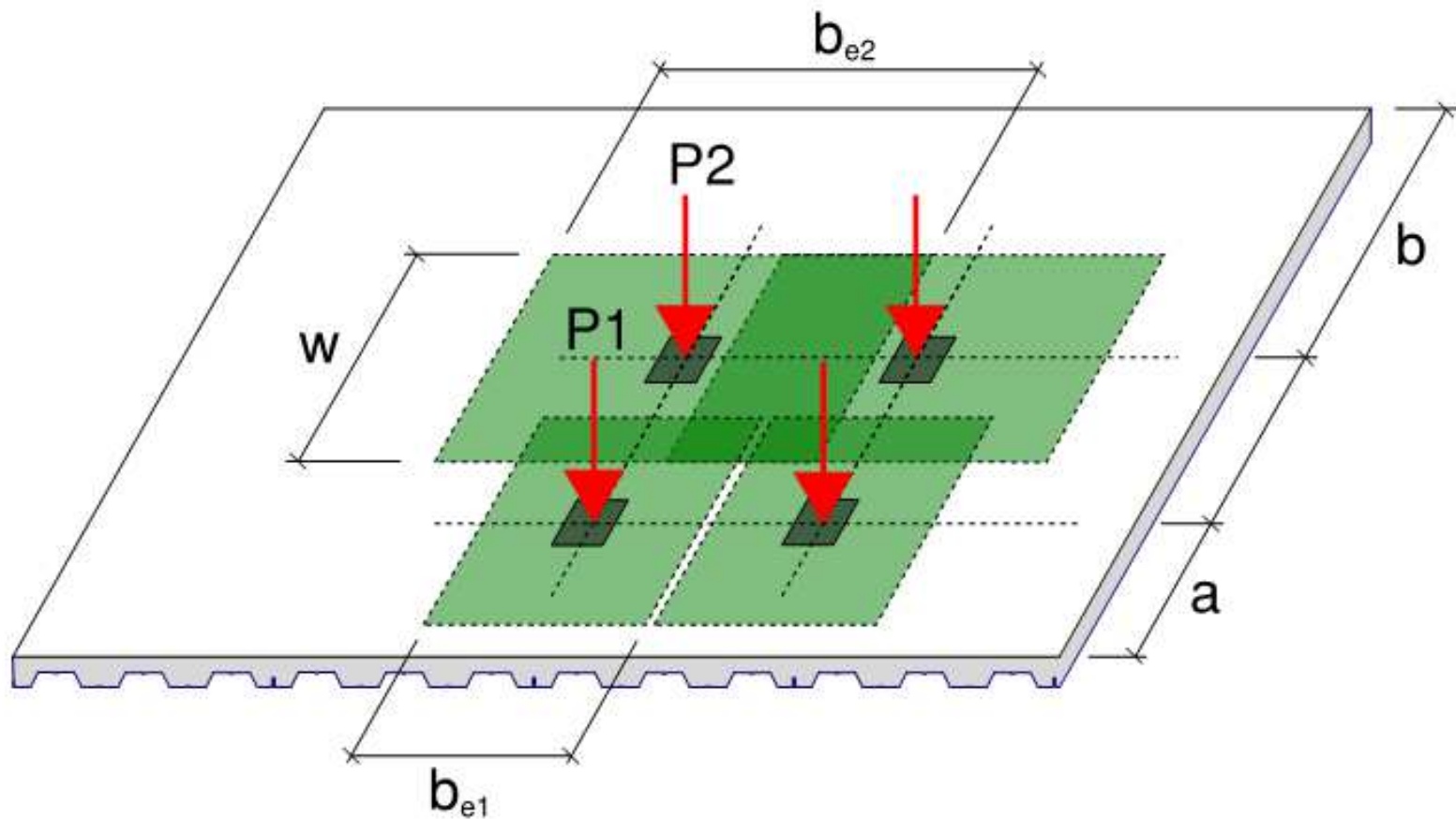

You guessed it 4 loads “In-line” and “adjacent”.

Example Problem



“What size lift can this floor support?”

Slab (FDDM Example 4)

- 2 x 12 composite deck
- 20 gage
- 4 ½” total depth
- 3 ksi NW concrete
- 9-0 clear span
- 25 psf concurrent LL
- 6x6 – W2.1xW2.1 WWR
- $d = 1.25$ ”

Assumed Lift

- 52” length
- 30” width
- 12” x 4.5” tires
- 2.5 mph

Example Problem, V_n

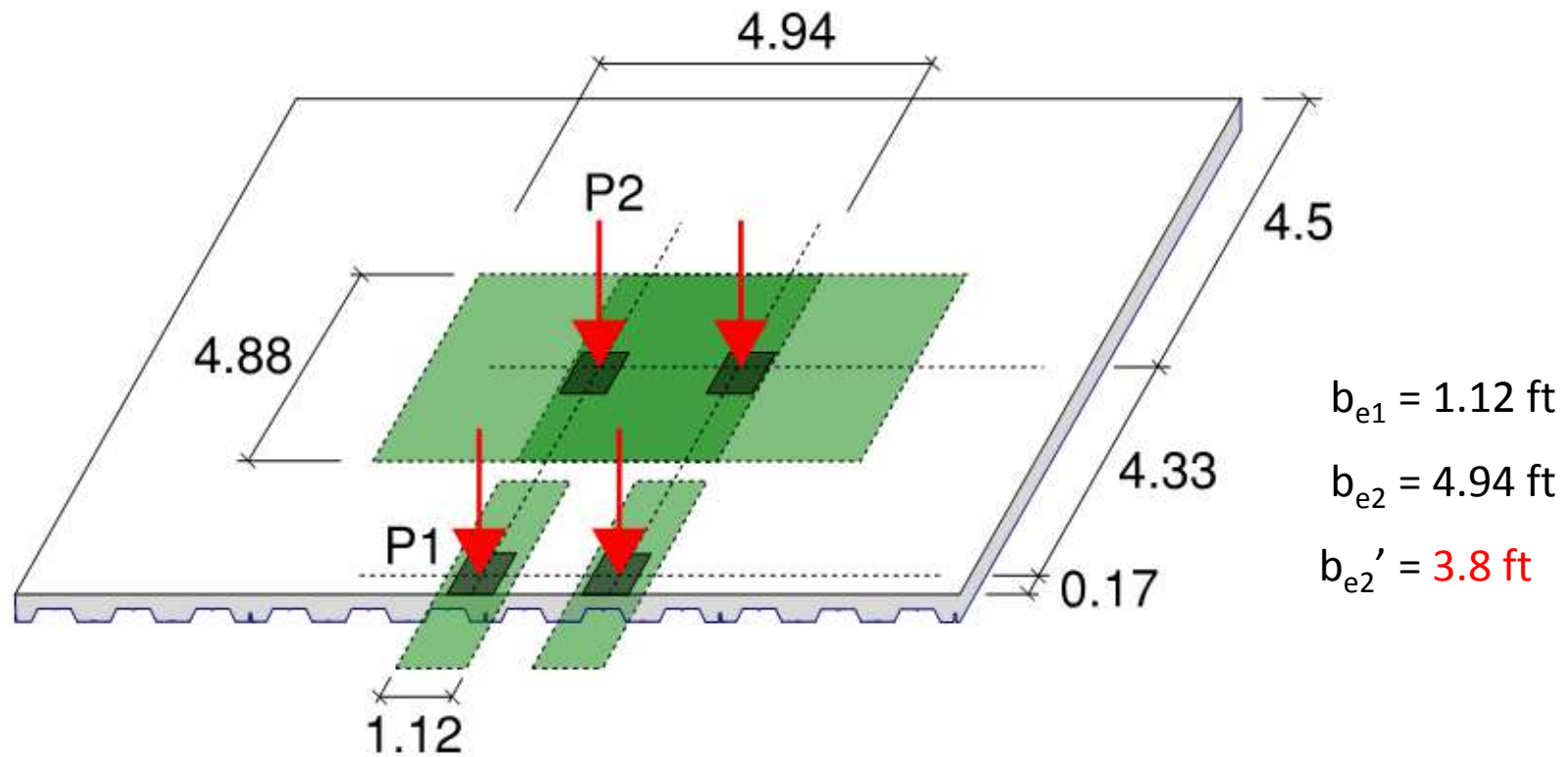

As a general rule for scissor lift shear,
 one tire near the support and
 smaller lift dimension “adjacent”.

Example Problem, V_n

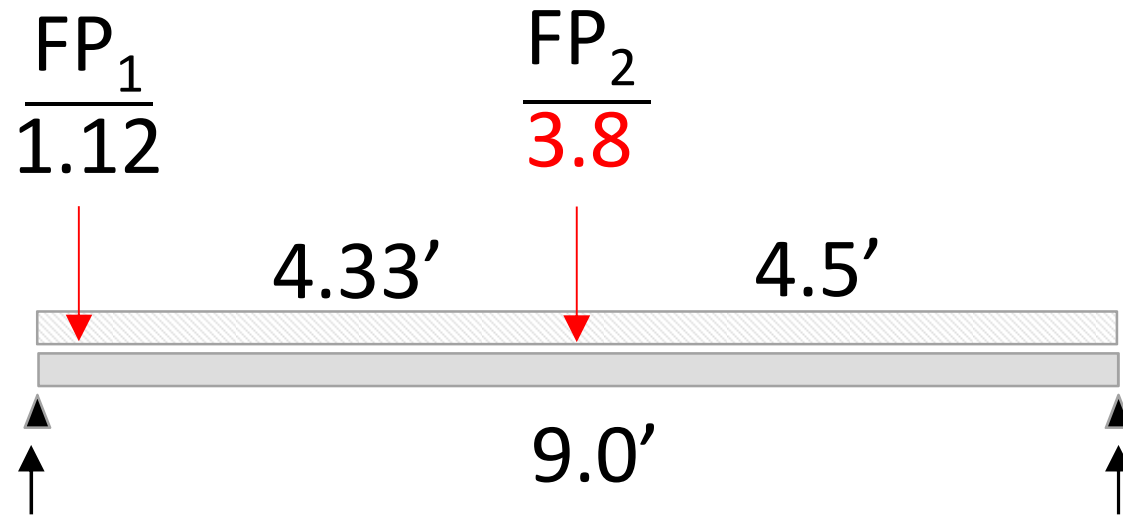

$$R_R = 4715 \text{ lbs} = \frac{53 \text{ plf} (9 \text{ ft})}{2} + \frac{25 \text{ plf} (1.6) (9 \text{ ft})}{2} + \frac{FP}{1.12 \text{ ft}} \left(\frac{0.17 \text{ ft}}{9 \text{ ft}} \right) + \frac{FP}{3.8 \text{ ft}} \left(\frac{4.5 \text{ ft}}{9 \text{ ft}} \right)$$

$$FP = 28943 \text{ lbs}$$

$$R_L = 4715 \text{ lbs} = \frac{53 \text{ plf} (9 \text{ ft})}{2} + \frac{25 \text{ plf} (1.6) (9 \text{ ft})}{2} + \frac{FP}{1.12 \text{ ft}} \left(\frac{8.83 \text{ ft}}{9 \text{ ft}} \right) + \frac{FP}{3.8 \text{ ft}} \left(\frac{4.5 \text{ ft}}{9 \text{ ft}} \right)$$

$$FP = 4264 \text{ lbs}$$

Example Problem, M_y

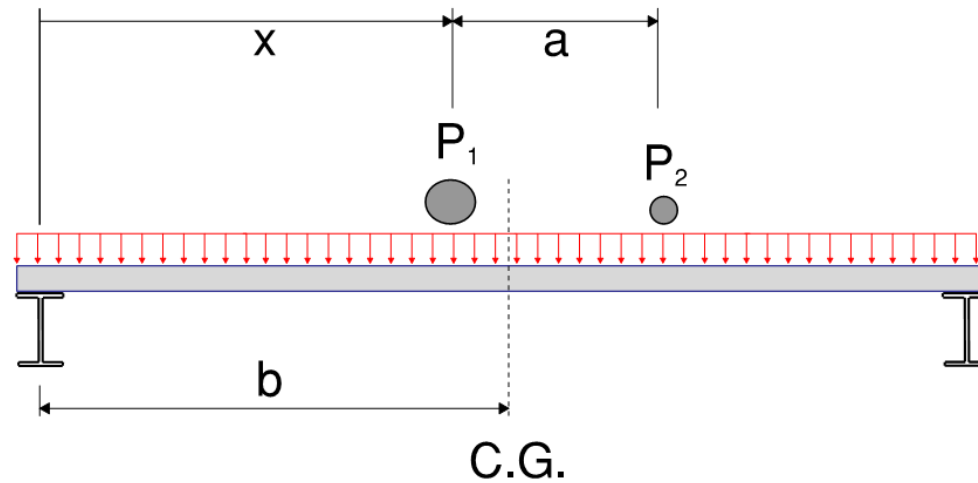

AISC 15th 3-223 – Maximum bending occurs when $x = b$ or when the larger load is over the center of gravity of all loads. So, where is C.G. ?

We know M_{\max} should be near midspan. Is this close enough?

Example Problem, M_y

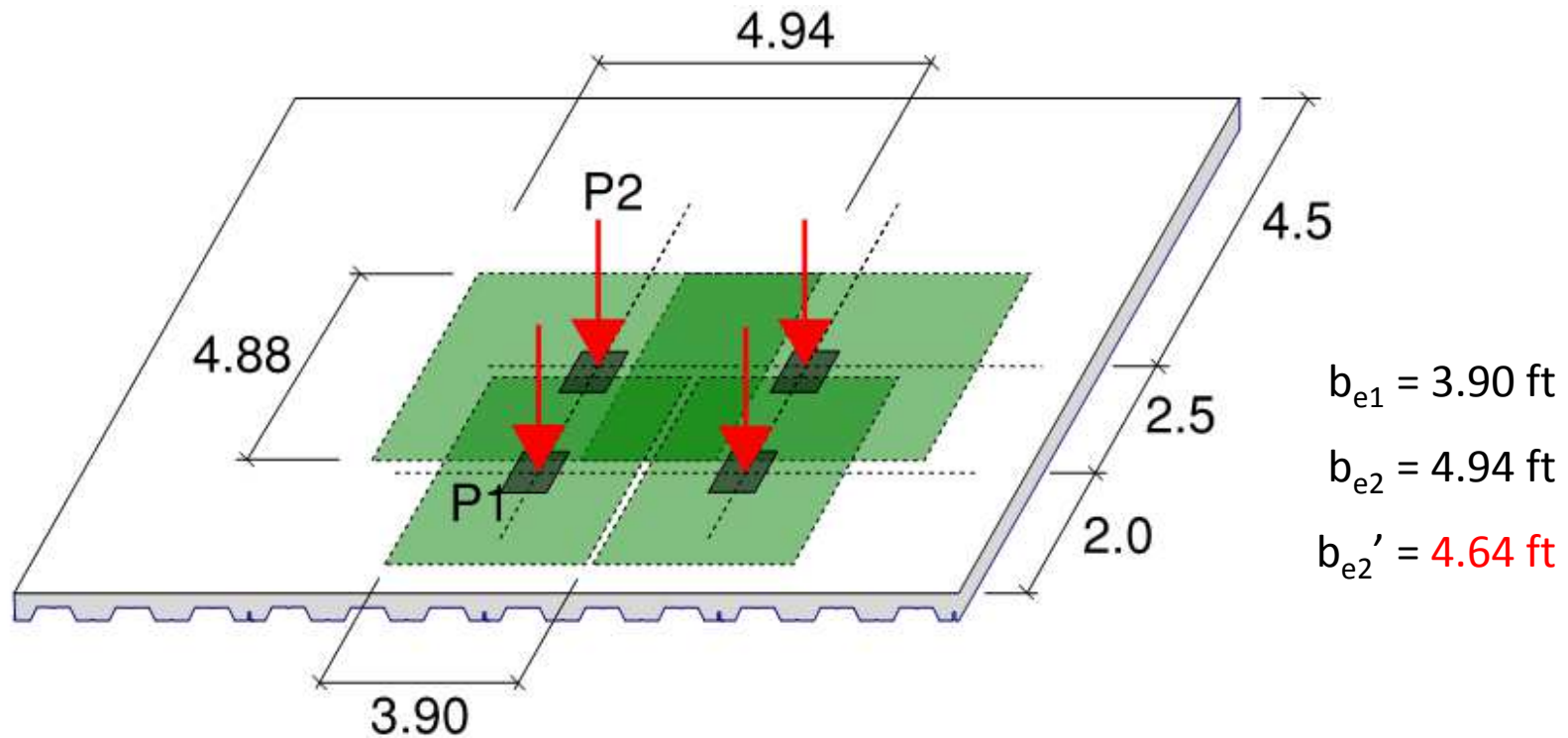

As a general rule for scissor lift bending, one tire at midspan is reasonable, but $a = 0.45L$ is more accurate. Smaller lift dimension “in-line”, but check rotated 90°.

Example Problem, M_y

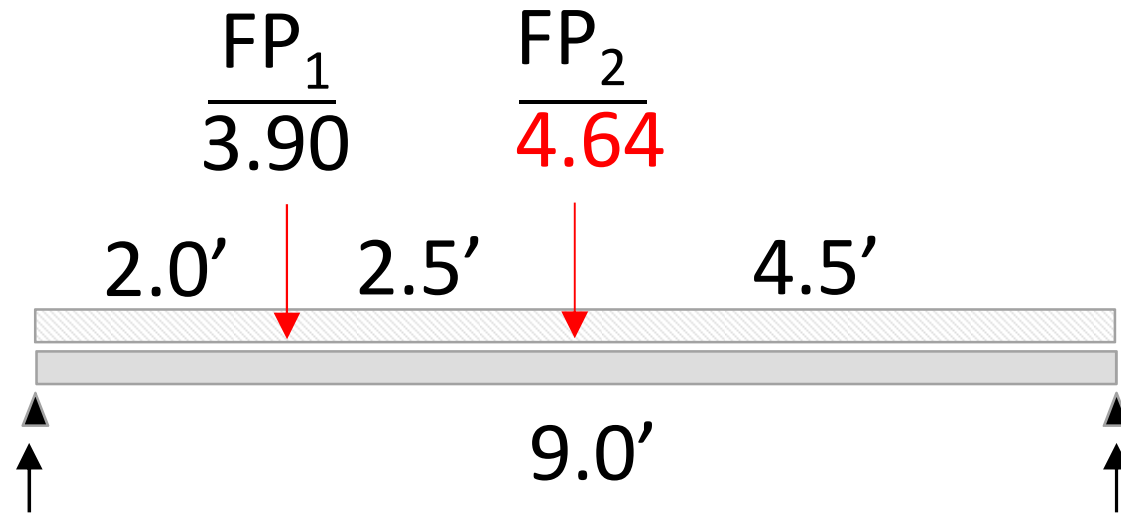

$$M_{@P1} = 3511 \frac{\text{ft} - \text{lbs}}{\text{ft}} = \frac{(53 \text{ plf} + 25 \text{ plf}(1.6))(2.0 \text{ ft})(7.0 \text{ ft})}{2} + \frac{FP(2.0 \text{ ft})(7.0 \text{ ft})}{(3.9 \text{ ft})9 \text{ ft}} + \frac{FP(4.5 \text{ ft})(2.0 \text{ ft})}{(4.64 \text{ ft})9 \text{ ft}}$$

$$FP = 4655 \text{ lbs}$$

$$M_{@P2} = 3511 \frac{\text{ft} - \text{lbs}}{\text{ft}} = \frac{(53 \text{ plf} + 25 \text{ plf}(1.6))(4.5 \text{ ft})(4.5 \text{ ft})}{2} + \frac{FP(2.0 \text{ ft})(4.5 \text{ ft})}{(3.9 \text{ ft})9 \text{ ft}} + \frac{FP(4.5 \text{ ft})(4.5 \text{ ft})}{(4.64 \text{ ft})9 \text{ ft}}$$

$$FP = 3465 \text{ lbs}$$

Computer model, $FP = 3410 \text{ lbs}$

Example Problem, M_w

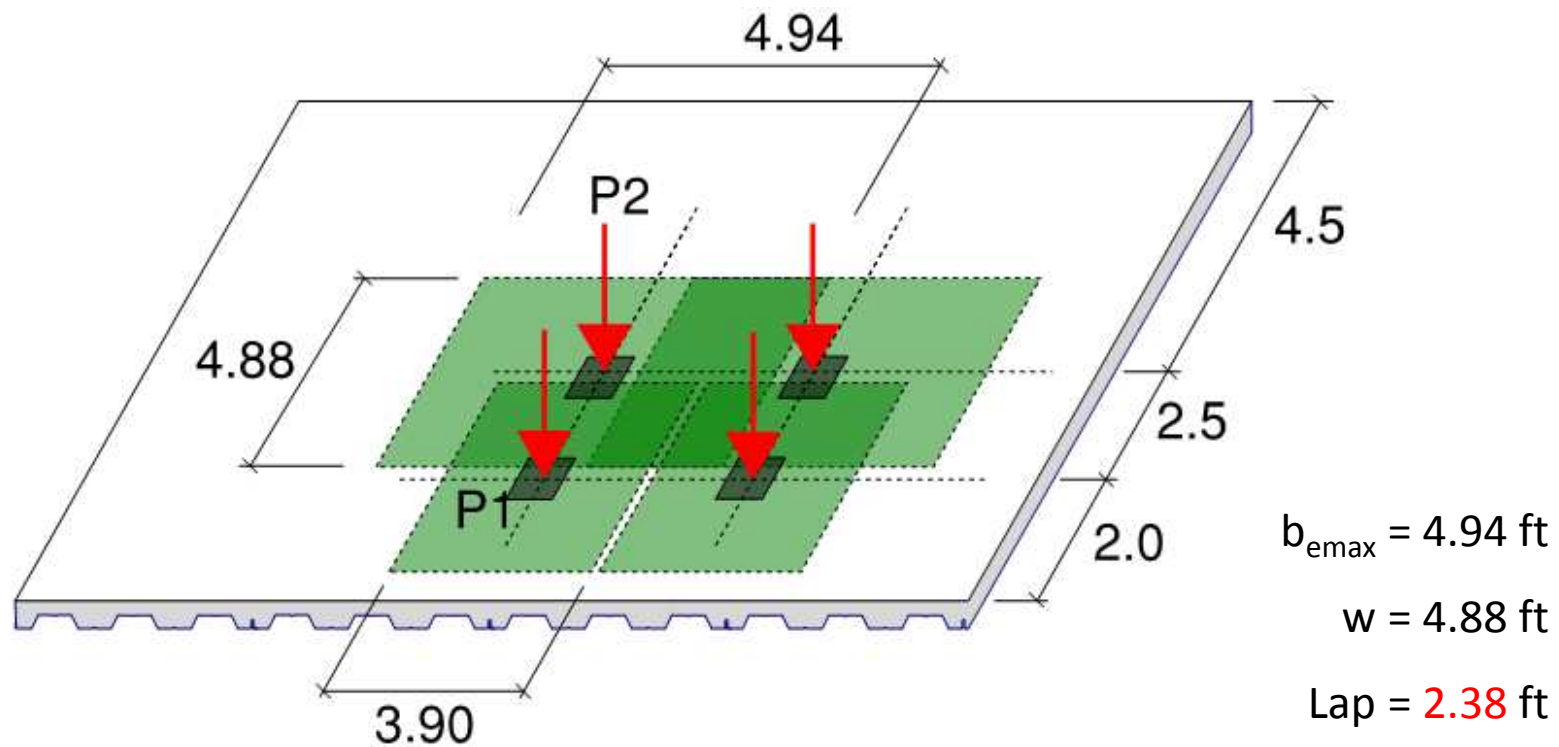

As a general rule for scissor lift weak axis, same lift location and orientation as M_y .

Example Problem, M_w

$$\Phi_w M_1 = \left(\frac{FP}{w} + \frac{FP(Lap)}{w^2} \right) \frac{12b_{emax}}{15}$$

Correction for "in – line" overlap

$$\Phi_w M_x = 5.5[\Phi_w M_1] \left[\frac{x}{b_{emax}} - \frac{1}{\pi} \sin \left(\frac{\pi x}{b_{emax}} \right) \right]$$

Correction for "adjacent" overlap

$$x = \frac{b_{emax}}{2} - \text{Adjacent Load spacing} > 0$$

$$\Phi_w M_w = \Phi_w M_1 + \Phi_w M_x$$

Moments are cumulative at x

$$\Phi_w M_w = \left(\frac{FP}{w} + \frac{FP(Lap)}{w^2} \right) \frac{12b_{emax}}{15} + 5.5 \left[\left(\frac{FP}{w} + \frac{FP(Lap)}{w^2} \right) \frac{12b_{emax}}{15} \right] \left[\frac{x}{b_{emax}} - \frac{1}{\pi} \sin \left(\frac{\pi x}{b_{emax}} \right) \right]$$

Example Problem, M_w

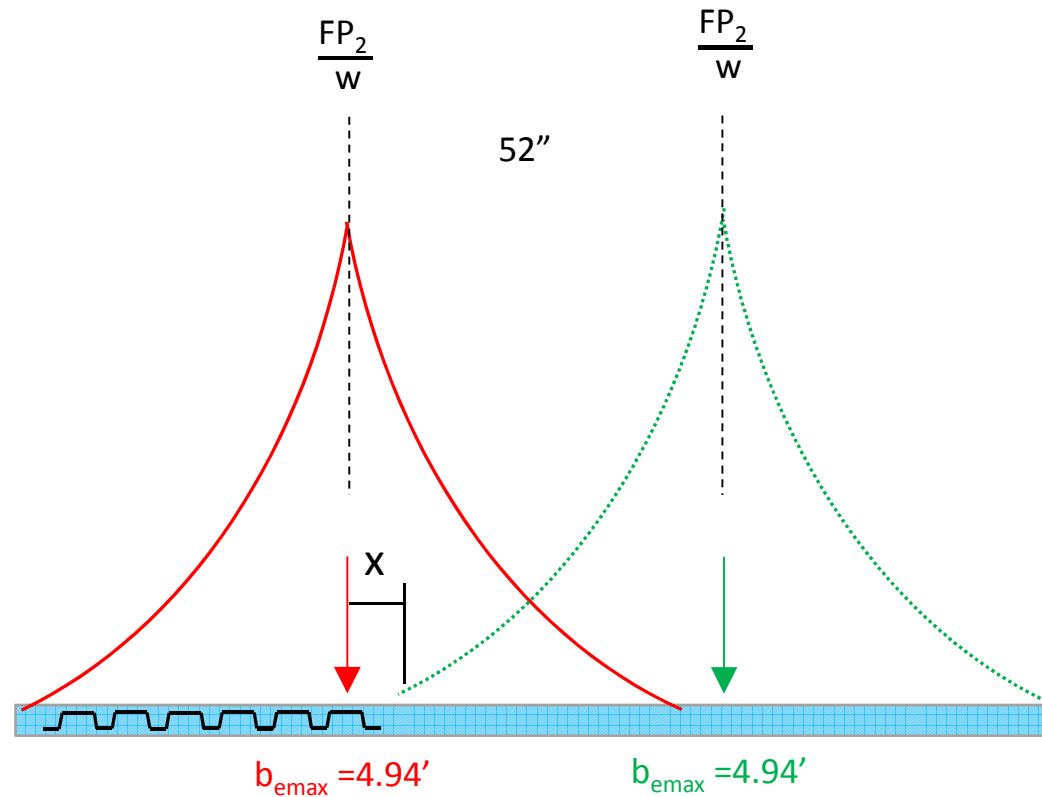

$$x = \frac{b_{emax}}{2} - \text{Adjacent Load spacing} > 0 = \frac{4.94'}{2} - \frac{52''}{12} = -1.86' \quad \text{Use } x = 0$$

Example Problem, M_w

$$\Phi_w M_w = \left(\frac{FP}{w} + \frac{FP(Lap)}{w^2} \right) \frac{12b_{emax}}{15} + 5.5 \left[\left(\frac{FP}{w} + \frac{FP(Lap)}{w^2} \right) \frac{12b_{emax}}{15} \right] \left[\frac{x}{b_{emax}} - \frac{1}{\pi} \sin \left(\frac{\pi x}{b_{emax}} \right) \right]$$

0

Typical for scissor lifts

$$2285 \text{ in} - \frac{\text{lbs}}{\text{ft}} = \left(\frac{FP}{4.88'} + \frac{FP(2.38')}{4.88'^2} \right) \frac{12(4.94')}{15}$$

Solve for FP = 1896 lbs

Computer model = 1893 lbs

Checks for deflection and punching are not shown, and did not control.
Maximum scissor lift wheel load is limited by weak axis bending = 1896 lbs.

What limits do we give the contractor?

Example Answer



FP = 1896 lbs from M_w

If loads are balanced:

$$\text{Lift} = 4\text{FP} = 7584 \text{ lbs}$$

Impact is unlikely, but possible if platform falls quickly. Try 25% impact.

$$\text{Lift} = 7584 / (1.25) = 6067 \text{ lbs}$$

In most cases, lift weight far exceeds platform capacity and travels at 2.5 mph. For construction, $F = 1.4$ is reasonable.

$$\text{Lift} = 6067 / (1.4) = 4334 \text{ lbs}$$

Product specs from on-line literature,

Weight = 2702 lbs

Capacity = 500 lbs

Total = 3202 lbs < 4334 lbs OK

FDDM Scissor Lift Tables?

1.5 x 6 Composite + 25 psf construction load

Slab	Gage	WWR	$\phi_b M_y$	$\phi_w M_w$	$\phi_d V_d + \phi_c V_c$	ϕP_u / Simple Span, lbs									
						5.0	5.5	6.0	6.5	7.0	7.5	8.0			
4.0" (t=2.5")	22	6x6-W2.1xW2.1	2492	2285	3615	2326	2198	2101	2026	1966	1916	1875			
		6x6-W2.9xW2.9	2492	3114	3615						2612	2556			
		4x4-W2.9xW2.9	2492	4560	3615			2615			2624	2628			
	20	6x6-W2.1xW2.1	2964	2285	3615	2326	2198	2101	2026	1966	1916	1875			
		6x6-W2.9xW2.9	2964	3114	3615						2612	2556			
		4x4-W2.9xW2.9	2964	4560	3615			2615			2624	2628			
	18	6x6-W2.1xW2.1	3822	2285	3615	2326	2198	2101	2026	1966	1916	1875			
		6x6-W2.9xW2.9	3822	3114	3615						2612	2556			
		4x4-W2.9xW2.9	3822	4650	3615			2615			2621	2625			
4.5" (t=3.0")	22	6x6-W2.1xW2.1	3012	2757	4252	2738	2591	2481	2395	2327	2271	2224			
		6x6-W2.9xW2.9	3012	3767	4252						3272	3179	3102	3039	
		4x4-W2.9xW2.9	3012	5539	4252			3340			3343	3344	3346	3349	
	20	6x6-W2.1xW2.1	3585	2757	4252	2738	2591	2481	2395	2327	2271	2224			
		6x6-W2.9xW2.9	3585	3767	4252						3272	3179	3102	3039	
		4x4-W2.9xW2.9	3585	5539	4252			3340			3343	3344	3346	3349	
	18	6x6-W2.1xW2.1	4628	2757	4252	2738	2591	2481	2395	2327	2271	2224			
		6x6-W2.9xW2.9	4628	3767	4252						3272	3179	3102	3039	
		4x4-W2.9xW2.9	4628	5539	4252			3340			3341	3341	3343	3346	
5.0" (t=3.5")	22	6x6-W2.1xW2.1	3546	3230	4734	3129	2967	2845	2750	2675	2613	2562			
		6x6-W2.9xW2.9	3546	4419	4734						3763	3660	3575	3505	
		4x4-W2.9xW2.9	3546	6517	4734			4015			4006	4000	3998	3997	3998
	20	6x6-W2.1xW2.1	4223	3230	4930	3129	2967	2845	2750	2675	2613	2562			
		6x6-W2.9xW2.9	4223	4419	4930						3763	3660	3575	3505	
		4x4-W2.9xW2.9	4223	6517	4930			4209			4180	4180	4175	4173	4173
	18	6x6-W2.1xW2.1	5461	3230	4930	3129	2967	2845	2750	2675	2613	2562			
		6x6-W2.9xW2.9	5461	4419	4930						3763	3660	3575	3505	
		4x4-W2.9xW2.9	5461	6517	4930			4209			4180	4180	4175	4173	4173

Capacities above are Ultimate wheel loads. Apply appropriate load, impact or unbalanced factors as applicable.

WWR located at slab centerline (d = t/2)

Positive Bending ($\phi_b M_y$), Weak Axis Bending ($\phi_w M_w$), Beam Shear ($\phi_d V_d + \phi_c V_c$), Punching Shear (ϕV_{pr}) and L/360 Deflection (Δ)

$\phi_w M_w$

ϕV_n

$\phi_b M_y$

Δ L/360

FDDM Scissor Lift Tables?

1938

2.0 x 12 Composite + 25 psf construction load

Slab	Gage	WWR	$\phi_b M_y$	$\phi_w M_w$	$\phi_d V_d + \phi_c V_c$	ϕP_u / Simple Span, lbs						
						6.0	7.0	8.0	9.0	10.0	11.0	12.0
4.5" (t=2.5")	22	6x6-W2.1xW2.1	2911	2285	4369	2101	1966	1875	1938	1955	1559	1152
		6x6-W2.9xW2.9	2911	3114	4369	2864	2679	2556	2641	2051	1559	1152
		4x4-W2.9xW2.9	2911	4560	4369	3192	3201	3215	2658	2051	1559	1152
	20	6x6-W2.1xW2.1	3511	2285	4715	2101	1966	1875	1938	1955	1955	1709
		6x6-W2.9xW2.9	3511	3114	4715	2864	2679	2556	2641	2665	2176	1709
		4x4-W2.9xW2.9	3511	4560	4715	3463	3476	3494	3466	2748	2176	1709
	18	6x6-W2.1xW2.1	4482	2285	5361	2101	1966	1875	1938	1955	1955	1955
		6x6-W2.9xW2.9	4482	3114	5361	2864	2679	2556	2641	2665	2665	2424
		4x4-W2.9xW2.9	4482	4560	5361	3965	3923	3743	3868	3862	3104	2424
5.0" (t=3.0")	22 gage	6x6-W2.1xW2.1	3431	2757	4769	2481	2327	2224	2165	2299	2067	1580
		6x6-W2.9xW2.9	3431	3767	4769	3389	3179	3039	2958	2663	2067	1580
		4x4-W2.9xW2.9	3431	5539	4769	3766	3767	3776	3383	2663	2067	1580
	20 gage	6x6-W2.1xW2.1	4140	2757	5116	2481	2327	2224	2165	2299	2299	2299
		6x6-W2.9xW2.9	4140	3767	5116	3389	3179	3039	2958	3140	2811	2248
		4x4-W2.9xW2.9	4140	5539	5116	4055	4060	4072	4088	3507	2811	2248
	18 gage	6x6-W2.1xW2.1	5294	2757	5764	2481	2327	2224	2165	2299	2299	2299
		6x6-W2.9xW2.9	5294	3767	5764	3389	3179	3039	2958	3140	3140	3140
		4x4-W2.9xW2.9	5294	5539	5764	4602	4612	4468	4350	4617	4046	3362
5.5" (t=3.5")	22	6x6-W2.1xW2.1	3966	3230	5190	2845	2675	2562	2482	2561	2594	2022
		6x6-W2.9xW2.9	3966	4419	5190	3893	3660	3505	3395	3298	2594	2022
		4x4-W2.9xW2.9	3966	6517	5190	4399	4391	4393	4078	3298	2594	2022
	20	6x6-W2.1xW2.1	4789	3230	5537	2845	2675	2562	2482	2561	2745	2745
		6x6-W2.9xW2.9	4789	4419	5537	3893	3660	3505	3395	3504	3504	2843
		4x4-W2.9xW2.9	4789	6517	5537	4713	4708	4713	4724	4238	3504	2843
	18	6x6-W2.1xW2.1	6133	3230	6185	2845	2675	2562	2482	2561	2745	2745
		6x6-W2.9xW2.9	6133	4419	6185	3893	3660	3505	3395	3504	3756	3756
		4x4-W2.9xW2.9	6133	6517	6185	5297	5296	5170	5008	5168	4974	4163

Capacities above are Ultimate wheel loads. Apply appropriate load, impact or unbalanced factors as applicable.

WWR located at slab centerline (d = t/2)

Positive Bending ($\phi_b M_y$), Weak Axis Bending ($\phi_w M_w$), Beam Shear ($\phi_d V_d + \phi_c V_c$), Punching Shear (ϕV_p) and L/360 Deflection (Δ)

$\phi_w M_w$ ϕV_n $\phi_b M_y$ Δ L/360



FDDM Scissor Lift Tables?

3.0 x 12 Composite + 25 psf construction load

Slab	Gage	WWR	$\phi_b M_y$	$\phi_w M_w$	$\phi_d V_d + \phi_c V_c$	ϕP_u / Simple Span, lbs						
						8.0	9.0	10.0	11.0	12.0	13.0	14.0
5.5" (t=2.5")	22	6x6-W2.9xW2.9	3679	3114	5006	2903	2903	2570	2025	1552	1153	812
		4x4-W2.9xW2.9	3679	4560	5006	3702	3243	2570	2025	1552	1153	812
		4x4-W4.0xW4.0	3679	6115	5006	3702	3243	2570	2025	1552	1153	812
	20	6x6-W2.9xW2.9	4390	3114	6206	2903	2903	2903	2691	2137	1676	1286
		4x4-W2.9xW2.9	4390	4560	6206	4251	4108	3320	2691	2137	1676	1286
		4x4-W4.0xW4.0	4390	6115	6206	4667	4108	3320	2691	2137	1676	1286
	18	6x6-W2.9xW2.9	5649	3114	6364	2903	2903	2903	2903	2903	2587	2108
		4x4-W2.9xW2.9	5649	4560	6364	4251	4251	4251	3855	3158	2587	2108
		4x4-W4.0xW4.0	5649	6115	6364	4791	4830	4636	3855	3158	2587	2108
6.0" (t=3.0")	22	6x6-W2.9xW2.9	4239	3767	5398	3329	3361	3221	2570	2026	1545	1136
		4x4-W2.9xW2.9	4239	5539	5398	4291	4052	3221	2570	2026	1545	1136
		4x4-W4.0xW4.0	4239	7464	5398	4291	4052	3221	2570	2026	1545	1136
	20	6x6-W2.9xW2.9	5054	3767	6598	3329	3361	3361	3361	2737	2182	1713
		4x4-W2.9xW2.9	5054	5539	6598	4895	4943	4125	3370	2737	2182	1713
		4x4-W4.0xW4.0	5054	7465	6598	5329	5098	4125	3370	2737	2182	1713
	18	6x6-W2.9xW2.9	6511	3767	7148	3329	3361	3361	3361	3361	3300	2722
		4x4-W2.9xW2.9	6511	5539	7148	4895	4943	4943	4784	3990	3300	2722
		4x4-W4.0xW4.0	6511	7465	7148	5800	5838	5724	4748	3990	3300	2722
6.5" (t=3.5")	22	6x6-W2.9xW2.9	4819	4419	5807	3627	3827	3827	3155	2535	1974	1495
		4x4-W2.9xW2.9	4819	6517	5807	4937	4918	3919	3155	2535	1974	1495
		4x4-W4.0xW4.0	4819	8815	5807	4937	4918	3919	3155	2535	1974	1495
	20	6x6-W2.9xW2.9	5745	4419	7007	3627	3827	3827	3827	3386	2732	2180
		4x4-W2.9xW2.9	5745	6517	7007	5349	5643	4985	4098	3386	2732	2180
		4x4-W4.0xW4.0	5745	8815	7007	6045	6070	4985	4098	3386	2732	2180
	18	6x6-W2.9xW2.9	7409	4419	7966	3627	3827	3827	3827	3827	3827	3391
		4x4-W2.9xW2.9	7409	6517	7966	5349	5643	5643	5643	4889	4073	3391
		4x4-W4.0xW4.0	7409	7966	7966	6926	6962	6889	5780	4889	4073	3391

Capacities above are Ultimate wheel loads. Apply appropriate load, impact or unbalanced factors as applicable.

WWR located at slab centerline (d = t/2)

Postive Bending ($\phi_b M_y$), Weak Axis Bending ($\phi_w M_w$), Beam Shear ($\phi_d V_d + \phi_c V_c$), Punching Shear (ϕV_{pr}) and L/360 Deflection (Δ)

$\phi_w M_w$ ϕV_n $\phi_b M_y$ $\Delta L/360$

Limit States

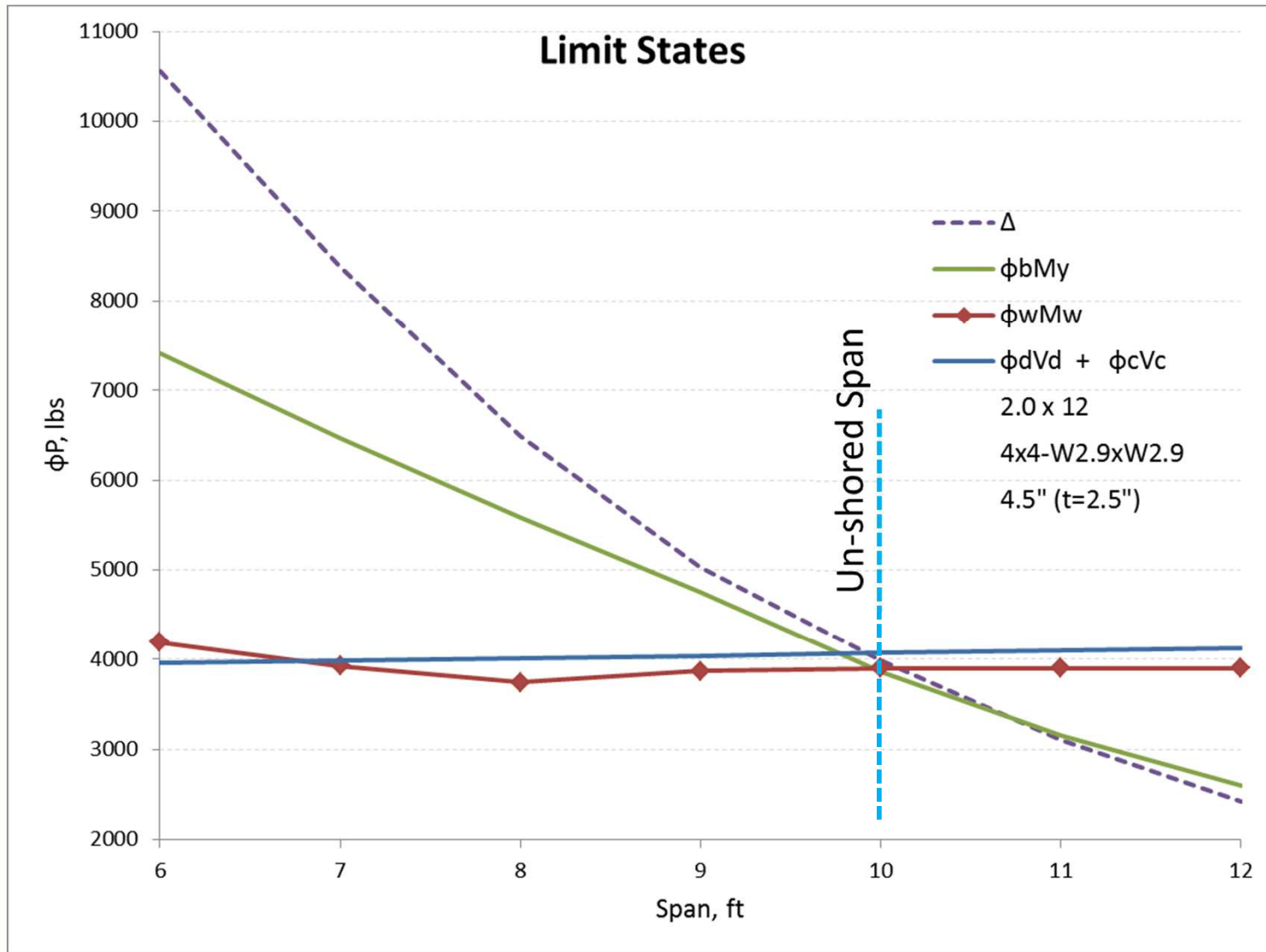

Data Rack



Slab

- 1.5 x 6 x 18 ga composite deck
- 5.0" Total Depth
- 3 ksi NW Concrete
- 7-0 Clear Span
- 40 psf Concurrent LL
- 6x6 – W2.9xW2.9 WWR
- d = 1.0"

Data Rack

- 42" deep
- 28" overall width
- 21" caster spacing
- 3" casters
- 3000# static capacity

Data Rack

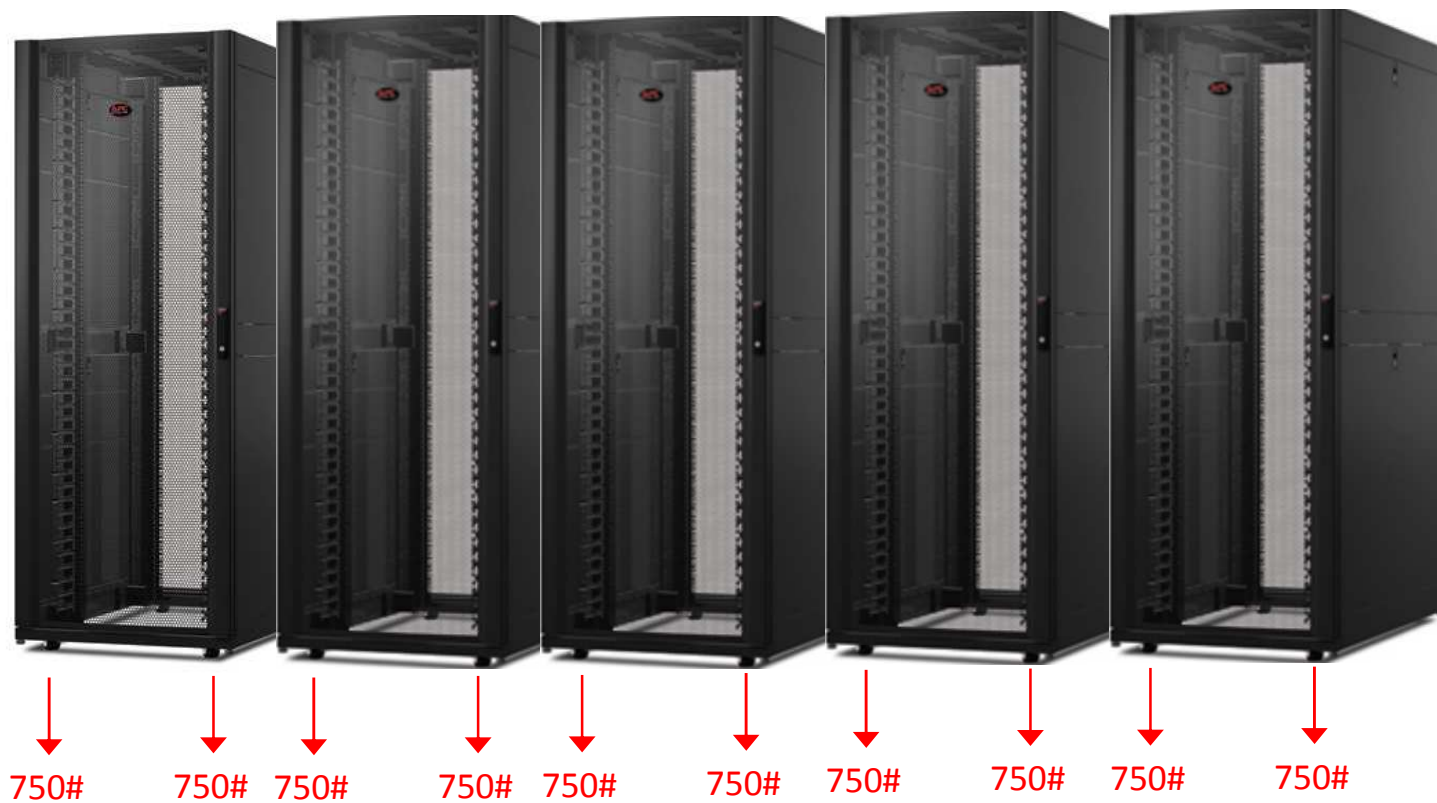

Data Rack(s)

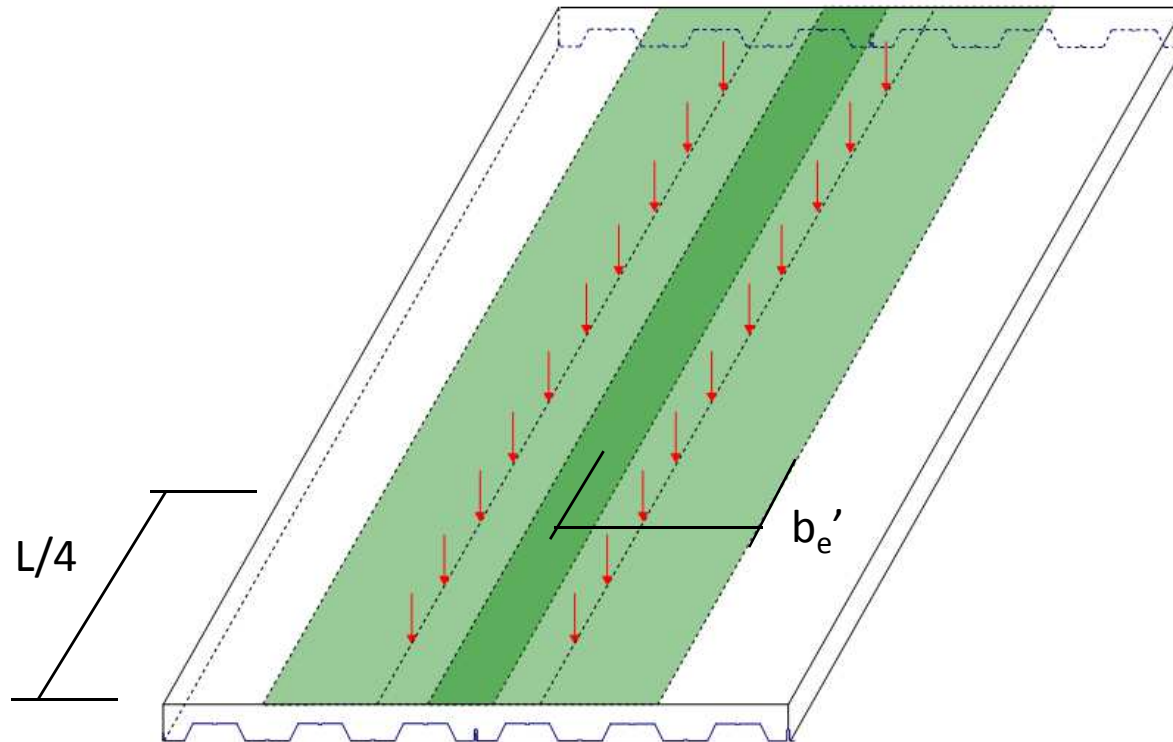

Line load analysis with b_e at $L/4$

Use b_e' for overlap of adjacent loads and calculation of V_n , M_y , Δ

M_w is a bit more complicated.

Data Rack

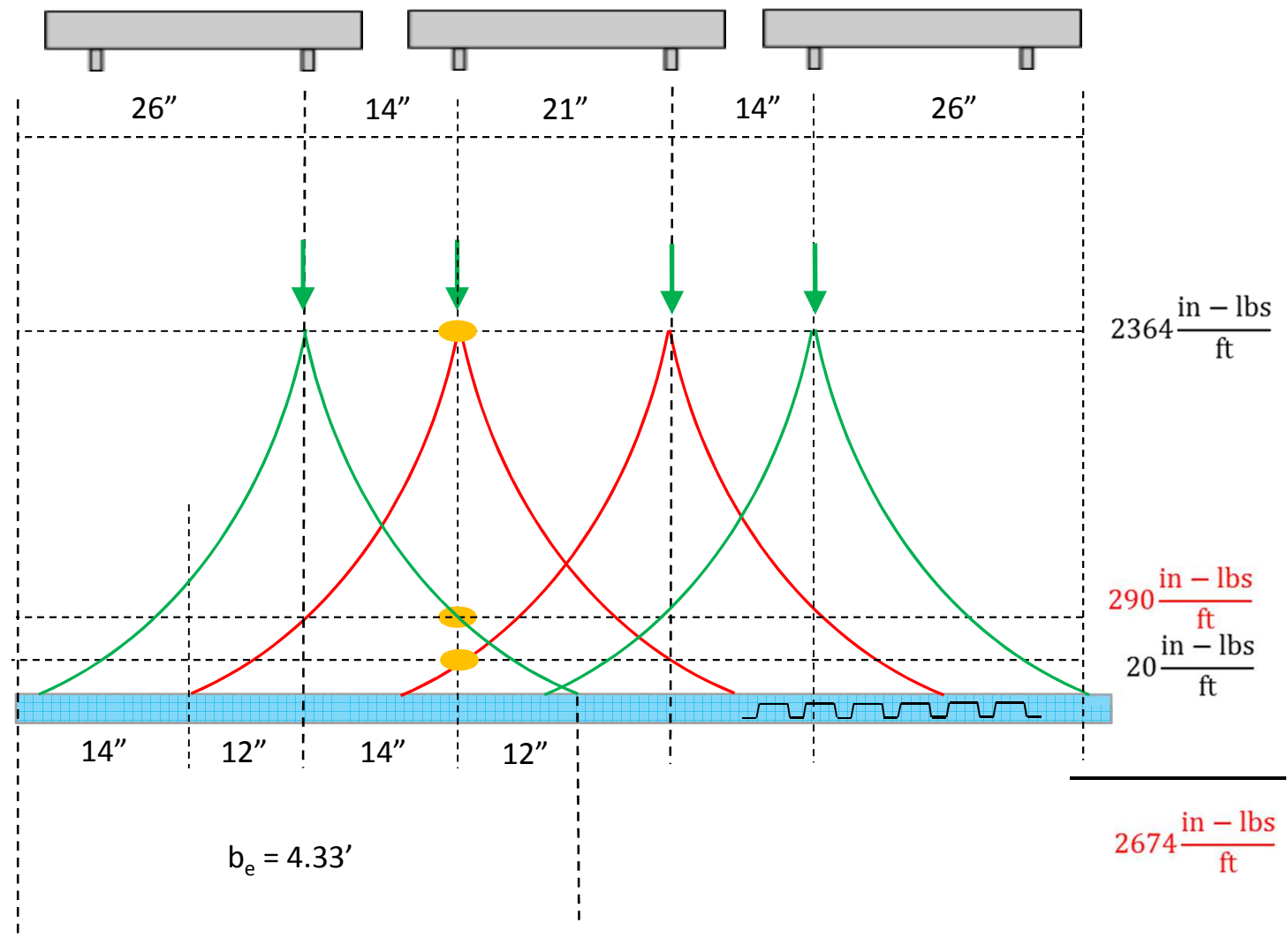

Form Deck

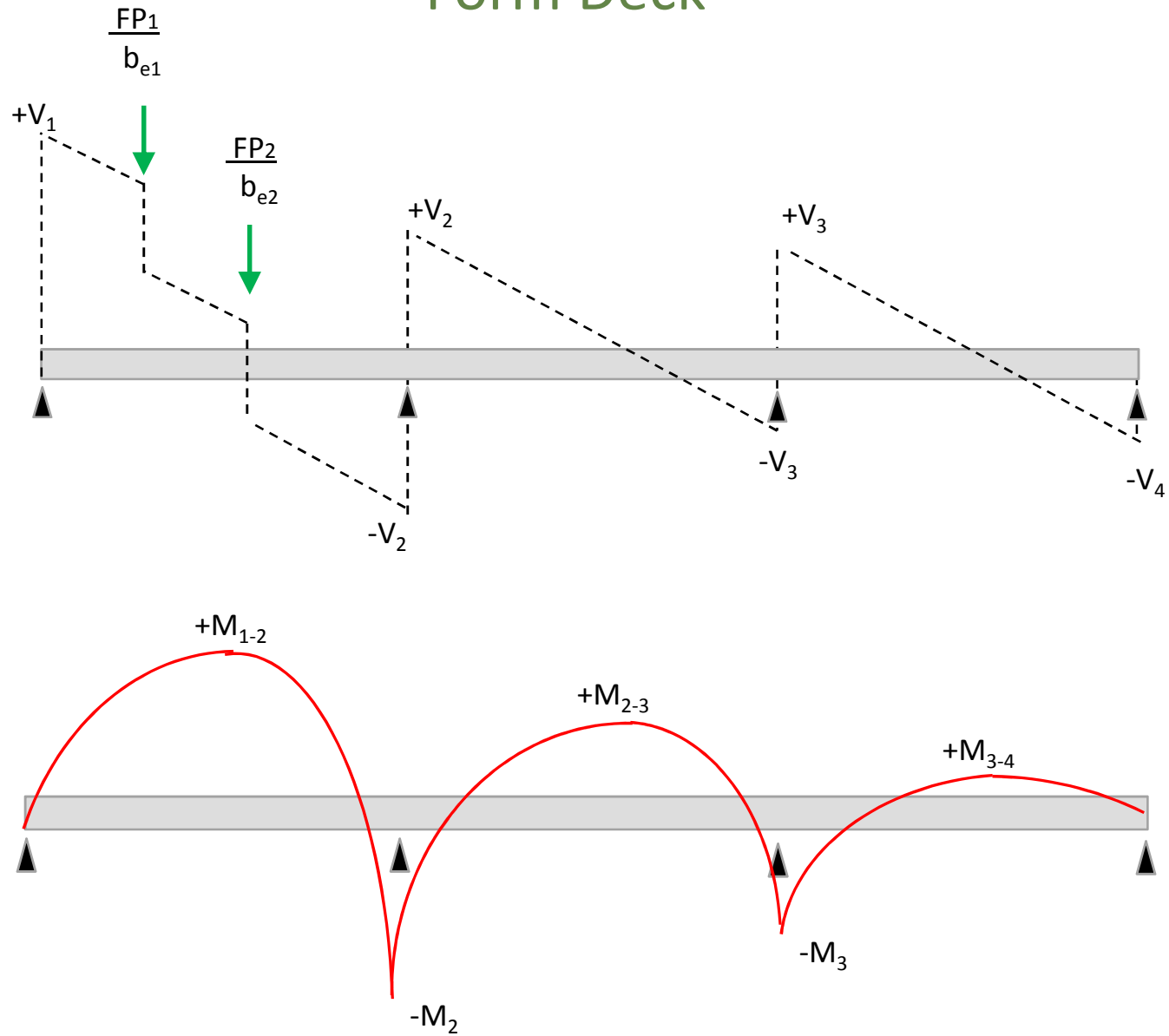

Steel Fibers

In theory, fibers are not a replacement for WWR as a tensile component, so $A_s = 0$.

If so, $M_w = 0$, which suggests $P = 0$.

This simply cannot be true.



Steel Fibers, Draft Proposals

Performance-Based Requirements for Fiber Dosage for Concentrated Loads on Composite Steel Deck Floor-Slabs

Section 2.4.B.11, Concentrated Loads, of the ANSI/SDI C-2017 Standard for Composite Steel Deck Floor-Slab permits a concentrated load to be laterally distributed perpendicular to the deck ribs (see Fig. 1). Accordingly, the concrete above the top of a steel deck is required to be designed as a one-way concrete slab, transverse to the deck ribs, in accordance with Chapter 7 of ACI 318 to resist the weak axis moment, M_{wa} , due to the concentrated load.

A procedure for calculating M_{wa} is provided in Section 2.4.B.11.b of the standard using the following equations (Eq. 2.4.15a and Eq. 2.4.15b in ANSI/SDI C-2017):

$$\begin{aligned} M_{wa} &= 12P \cdot b_e / (15W) && \text{in.-lb/ft} && \text{Single load analysis. Use new} \\ &= P \cdot b_e / (15W) && \text{N-mm/mm} && \text{for cluster loads.} \end{aligned}$$

where,

P = magnitude of concentrated load; lb (N)

b_e = effective width of concentrated load, perpendicular to the deck ribs; in. (mm)

W = effective length of concentrated load, parallel to the deck ribs; in. (mm)

This technical bulletin provides a methodology to calculate the required fiber dosage for a given application to permit the use of fibers in lieu of welded-wire reinforcement (WWR).

Summary Page

- Use P/b_e and simple beam mechanics
- M_w often limits capacity; increase d or A_s
- Cluster Loads – for $M_y V_n \Delta$, use b_e'
- Grouping loads is overly conservative
- Replace SDI M_w equation with **new**
- Check with supplier for $M_n < M_y$



Polling Question #2

What loads are included in Transverse (weak axis) bending analysis?

- a) Dead + Concentrated
- b) Live + Concentrated
- c) Concentrated only
- d) Dead + Live + Concentrated



Polling Question Answers

Which Limit State is NOT Applicable for Designing Concentrated Loads on Concrete Slabs on FLOOR Deck?

B) Web Crippling

What loads are included in Transverse (weak axis) bending analysis?

C) Concentrated only



Questions ?



Copyright © 2018 Steel Joist Institute. All Rights Reserved.

Presented by:

Cody Trueblood, New Millennium

Mike Antici, NUCOR