

Design Project: Final Report

Date of Report Issue: November 5, 2020

ME 465



Abel Aldape
Martin Dorantes
Natalie McDonald

Table of Contents

<i>Introduction</i>	3
Table 5: Bending and Wear Stresses	5
<i>Approach</i>	7
Table 1: Dimensions for the Chosen Worm	7
Table 2: Dimensions for the Chosen Worm Gear	7
<i>Results</i>	7
Table 3: Team Calculations	8
Table 4: Team Calculations Continued	8
Table 5: Bending and Wear Stresses	8
<i>Discussion of Results</i>	11
<i>Conclusion</i>	12
<i>References</i>	13

Introduction

The design project for Machine Design II consists of operating a winch, which requires a worm-gear mesh to be used. The worm experiences an input torque of 1,500 rpm from an electric motor. The worm gear will have a speed between 30 and 35 rpm. A requirement of a peak torque of 4,000 lbf*in is expected in the operating temperature of 120 degrees Fahrenheit. The output power produced does not have to exceed 1.2 hp. It is given that the winch drum radius is 8 inches and operates 4 to 5 hours a day. The design project figure is shown in Figure 1. For Progress Report #1, a worm-gear mesh that meets the requirements will be made by performing force, bending, and wear analyses. The team has assumed the design factor is 1.2 for the gear teeth. The designed worm-gear mesh will be self-locking. Gear and worm selections will be made using Rush Gears that meet the design requirements [2]. For Progress Report #2, the shaft from bearing 1 to 2 in Figure 2 will be designed. The stress and deflection constraints will be accounted for to support the worm gear. The final part of the project will consist of a Final Report which summarizes the design selections.

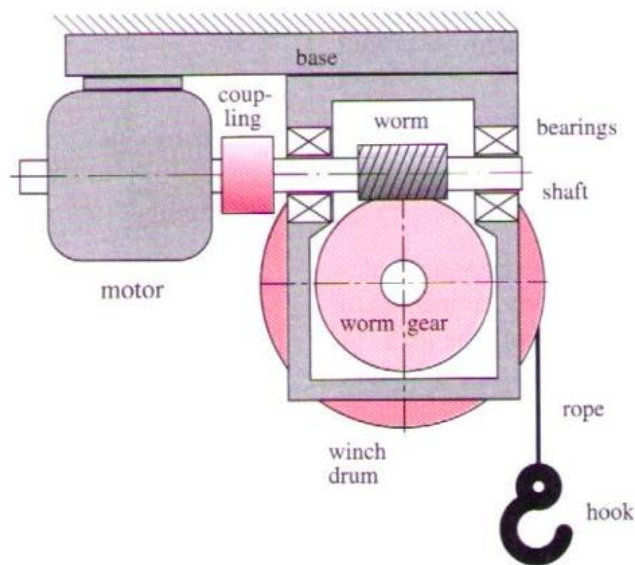

Figure 1: Front View of the Design Project Problem [1]

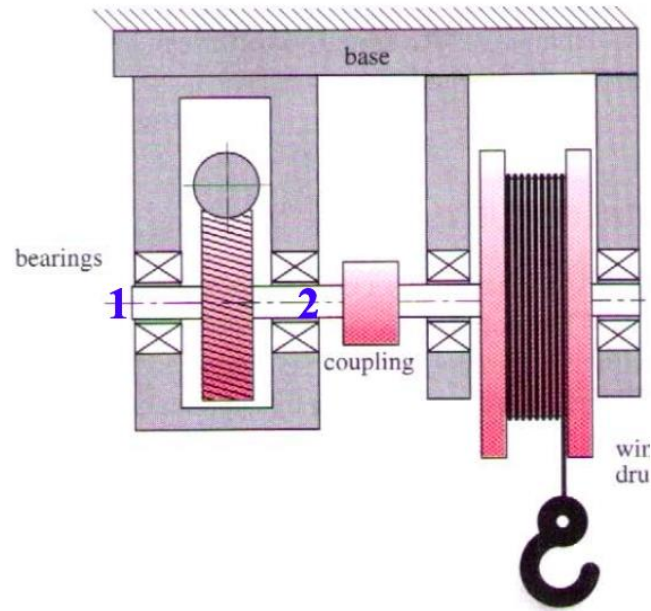

Figure 2: Side View of the Design Project Problem [1]

Summary

The goal for the first progress report was to perform an AGMA safety analysis to determine if the bending and wear stresses were acceptable for our gear selections. Our team chose the worm gear WB630DL and the worm LW3L from the Rush Gears website. Below is a sample of the calculations made to ensure the gears were able to complete the design parameters and safety requirements.

$$P_x = P_t = \frac{\pi}{p} \quad [\text{Equation 1}]$$

$$C = (d_w + d_G)/2 \quad [\text{Equation 2}]$$

$$L = P_x * N_w \quad [\text{Equation 3}]$$

$$V_w = (\pi d_w n_w)/12 \quad [\text{Equation 4}]$$

$$V_G = (\pi d_G n_G)/12 \quad [\text{Equation 5}]$$

$$V_s = (V_w)/\cos\lambda \quad [\text{Equation 6}]$$

$$W = W^x / (\cos(\text{Normal}) * \cos(\lambda) - f \sin(\lambda)) \quad [\text{Equation 7}]$$

The chosen worm gears allowable and actual stresses can be seen here. Both the bending and wear stresses have acceptable actual stress and satisfy the gear selections for the design project.

Table 5: Bending and Wear Stresses

Bending		Wear	
Bending Stress (Actual)	Bending Stress (Allowable)	Wear (Actual)	Wear (Allowable)
1254.2	1254.7	360.6	1650

The second progress report focused on the shaft required to support the worm gear. It would be designed to satisfy the deflection requirements of shafts. To do this the team made prior decisions for basic dimensions and created bending moment, shear, and torque diagrams. These figures can be found in the results portion of the report. For both progress report 1 and 2, are team received constructive criticism that our reports needed to provide the equations our excel file used. The equations for the factor of safety and deflection are given here.

$$d_y = \left[\left(\frac{16*n}{\pi*S_y} \right) * \left(4(k_f * m_a)^2 + 3(k_{fs} * T_m)^2 \right)^{1/2} \right]^{1/3} \quad \text{[Equation 8]}$$

$$k_f = 1 + q(k_t - 1) \quad \text{[Equation 9]}$$

$$k_{fs} = 1 + q_s(k_{ts} - 1) \quad \text{[Equation 10]}$$

Where q is found in Figure 6-26, k_t & k_{ts} come from Table 7-1, and q_s comes from Figure 6-27 of the textbook. All equations above refer to the static yield analysis of the preliminary shaft selection process, guiding the team to their chosen shaft. The next step for the team was to perform fatigue failure analysis, given below.

$$d_f = \left[\left(\frac{16*n}{\pi} \right) * \left(\frac{2*k_f*m_a}{S_e} + \frac{\sqrt{3}*k_{fs}*T_m}{S_{UT}} \right) \right]^{1/3} \quad \text{[Equation 11]}$$

$$S_e = k_a k_b k_c k_d k_e k_f S_e' \quad \text{[Equation 12]}$$

$$k_a = a S_{ut}^b \quad \text{[Equation 13]}$$

$$k_b = 1.24 d^{-0.107} \quad \text{[Equation 14]}$$

$$S_e' = 0.5 S_{ut} \quad \text{[Equation 15]}$$

Where k_c & k_d are 1 due to bending stress. k_e was found in Table 6-4 of the textbook. Torque, T_m , and maximum bending moment, m_a , were found and used in the equations above to perform the fatigue failure analysis. Once d_f was calculated, the team moved to pressure fit and hub stresses for the hub & shaft. All equations are documented below.

$$P_{max} = \frac{E*\delta_{max}}{2d^3} * \frac{(d_o^2-d^2)(d^2-d_i^2)}{d_o^2-d_i^2} \quad \text{[Equation 16]}$$

$$P_{min} = \frac{E \cdot \delta_{min}}{2d^3} * \frac{(d_o^2 - d^2)(d^2 - d_i^2)}{d_o^2 - d_i^2} \quad [\text{Equation 17}]$$

$$\sigma_{T,Shaft} = -P_{max} \quad [\text{Equation 18}]$$

$$\sigma_{r,Shaft} = -P_{max} \quad [\text{Equation 19}]$$

$$\sigma_{T,Hub} = P_{max} * \left(\frac{d_o^2 + d^2}{d_o^2 - d^2} \right) \quad [\text{Equation 20}]$$

$$\sigma_{r,Hub} = -P_{max} \quad [\text{Equation 21}]$$

$$\sigma'_s = \sqrt{(\sigma_1^2 - \sigma_1 \sigma_2 + \sigma_2^2)} \quad [\text{Equation 22}]$$

$$\sigma'_H = \sqrt{(\sigma_1^2 - \sigma_1 \sigma_2 + \sigma_2^2)} \quad [\text{Equation 23}]$$

$$n_s = \frac{S_y}{\sigma'} \quad [\text{Equation 24}]$$

$$n_H = \frac{S_y}{\sigma'} \quad [\text{Equation 25}]$$

The equations above guided the team in calculating the safety factors for the shaft and hub/bearings to ensure our system would not fail.

The shaft drawing can be seen in the results section of the report. After the deflection and factor safety calculations were made, our team determined the shaft was of acceptable dimensions to complete the design requirements.

Finally, our team chose the appropriate bearings for the design project. When creating the free body diagram in Figure 3, we noted the axial force at A needed for equilibrium. For that reason, we selected a thrust bearing with dimensions

Width = .63 in
Inner Diameter = 1.18 in
Outer Diameter = 2.05 in

At bearing B, we selected a cylindrical roller bearing due to its ability to support some radial load and its performance at high speeds. It has dimensions

Width = .63 in
Inner Diameter = 1.18 in
Outer Diameter = 2.44 in

This design project taught our team a lot about efficiency with programming. When we did a similar project in Machine Design I we did many of the calculations by hand, which made

iterating the design inefficient. By programming equations into excel, we could select different gear sets and experiment until the requirements were satisfied.

Approach

Our team began the project by creating a shared excel sheet and then referencing example problem 13-10 to begin coding [3]. Our goal was to code all necessary equations using the example problem inputs, to ensure the results were correct. After doing this we began considering which gears would be chosen and changed the respective input values in the code. The only major choice for the gear-worm set was the materials due to the wear factor for the AGMA design. We wanted to try and maximize this value, so with the options available to us we decided on using a high-grade steel for the worm, and bronze for the gear. The next step was simply to input the dimensions for both the worm and the gear and compare the results to ensure they met AGMA standards.

Table 1: Dimensions for the Chosen Worm

Worm	
Pitch diam. (in)	3
Face width (in)	5.5
N_W (teeth)	1
n_W (rev/min)	1200
HP (hp)	1
Kw	60

Table 2: Dimensions for the Chosen Worm Gear

Gear	
Pitch(t/in)	6
Face width (in)	1
N_G(teeth)	30
f	0.04
Pres. Angle (deg)	14.5

For this portion of the project, the team found it beneficial to follow Examples 13-10 and 7.2 for guidance [3]. Using Excel, the team was able to perform the Intermediate Shaft Analysis taking what was calculated in the bending and wear analysis. Some changes had to be made when obstacles came during the shaft analysis. A new gear had to be chosen to fit the project parameters; one with 45 gear teeth instead of the original 30. This change allowed for the gear speed to exist between the $30 \leq n_g \leq 35$ rev/min, which we calculated to be 33.33 rev/min. Once the new drum gear was chosen, the team started the free-body diagram showing the forces and torsion acting on the gear shaft shown in Figures 3- 6, calculating the magnitude of forces at each point in each direction of the given shaft diagram and the torque acting on the shaft.

Results

In Tables 3 and 4, you can see all the calculations that were made to determine the worm-gear dimensions and important factors. These were necessary to determine an allowable and actual

bending stress, as well as the allowable and actual wear of the gears. Table 5 has the results of the AGMA design, and clearly shows that our actual bending stress is much lower than the allowable stress. The wear design factor also shows that our worm-gear set will be more than adequate in guarding against wear.

Table 3: Team Calculations

$p_x = p_t$	p_n	d_G (in)	d_W (in)	C	Lead (in)	λ (degree)	Φ_n (degree)	V_w (ft/min)	n_G (rev/min)	C_s Materials Factor
0.52360	0.522792618	5	3	4	0.5236	3.180	14.5	942.48	40	1383.68

Table 4: Team Calculations Continued

V_G (ft/min)	V_s	W_{wt} (lbf)	W	W^y (lbf)	W^z (lbf)	W_{Ga}	W_{Gr}	W_{Gt}	Addendum, a	Dedendum, b_G	η %
52.36	943.9	35.0141	373.9	93.62	360.62	-35.01	-93.62	-360.62	0.1928414	0.1928414	57.22%

Table 5: Bending and Wear Stresses

Bending		Wear	
Bending Stress (Actual)	Bending Stress (Allowable)	Wear (Actual)	Wear (Allowable)
1254.169831	1254.169831	360.6189015	1650

The free body, shear, moment, and torque diagrams were created by hand and shown in Figure 3-6. The reaction forces were found using these diagrams to be able to find the maximum moment torque that would be applied to the shaft. These values were inputted into the Excel spreadsheet the team created. The safety factor for the shaft was found to be 5.48. A different Excel spreadsheet was used to find the deflections that would occur along the shaft to make sure they do not exceed the maximum range of slope and transverse deflection. With the gear having a pitch of 6, the team wanted the transverse deflection to be less than 0.010 in. The deflection at the ends of the shaft is 0 in with the middle having a deflection of $-3.26E-6$.

The free body diagram (Figure 3) was created along the xyz axes with the three forces acting on the worm. W_{GT} , W_{GR} , and W_{GA} were all calculated with the information in Table 4 and 5. To find the remaining reaction forces, a static equilibrium study was conducted using the sum of moments and forces. The resulting reaction forces were as follows: $F_{ax} = 28.01$, $F_{ay} = 41.9$, $F_{az} = 144.3$, $F_{bz} = 144.3$, $F_{by} = 33$ (all in lbf).

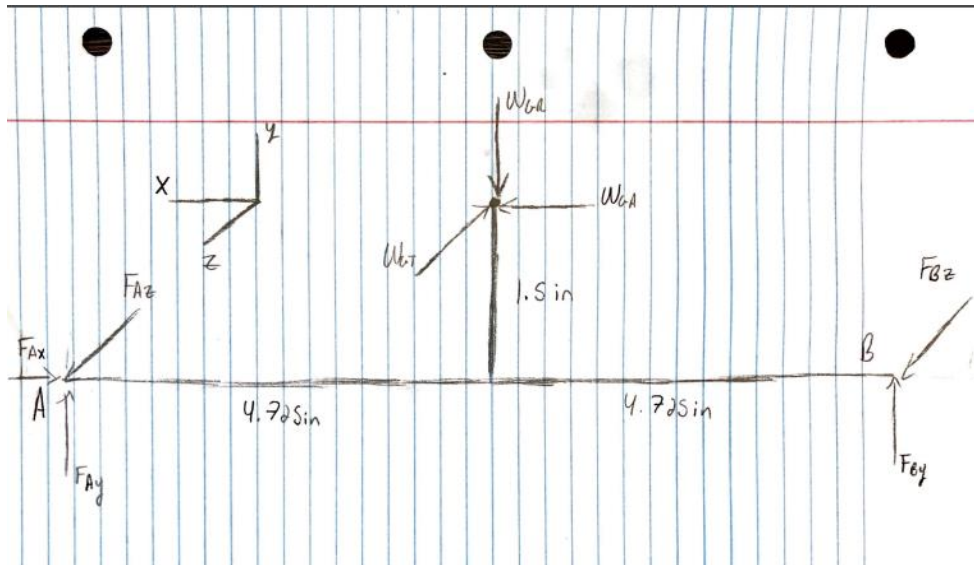

Figure 3: Free Body Diagram of Shaft

The shear diagram (Figure 4) relies only on point loads acting on the shaft and was also constructed along two different planes as shown in the picture. From the results it is clear the shear is zero at point B of the shaft as it should be for both planes.

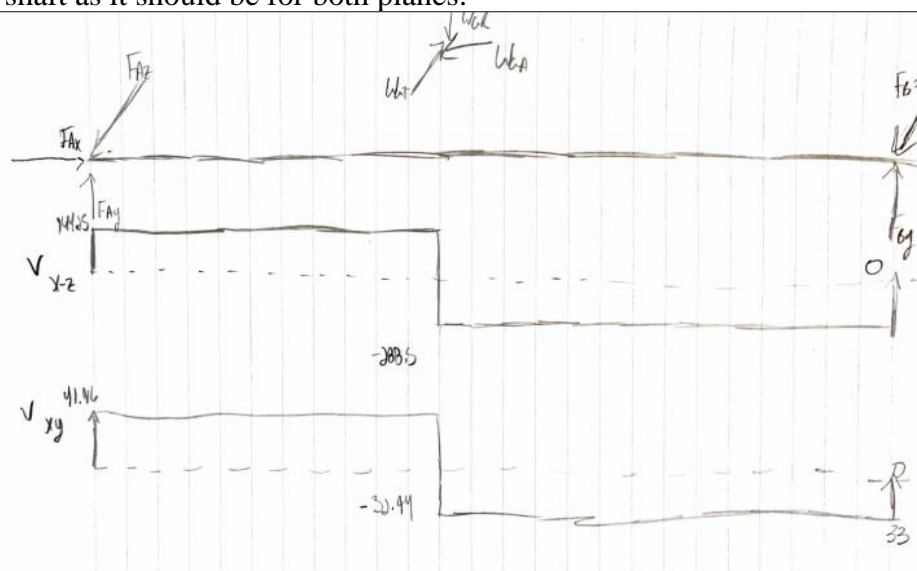

Figure 4: Plane Shear Diagrams

The moment diagram (Figure 5) was also constructed along two planes and shows a maximum moment in the middle of the shaft as expected. The total moment acting on the shaft is simply the magnitude of the two moments.

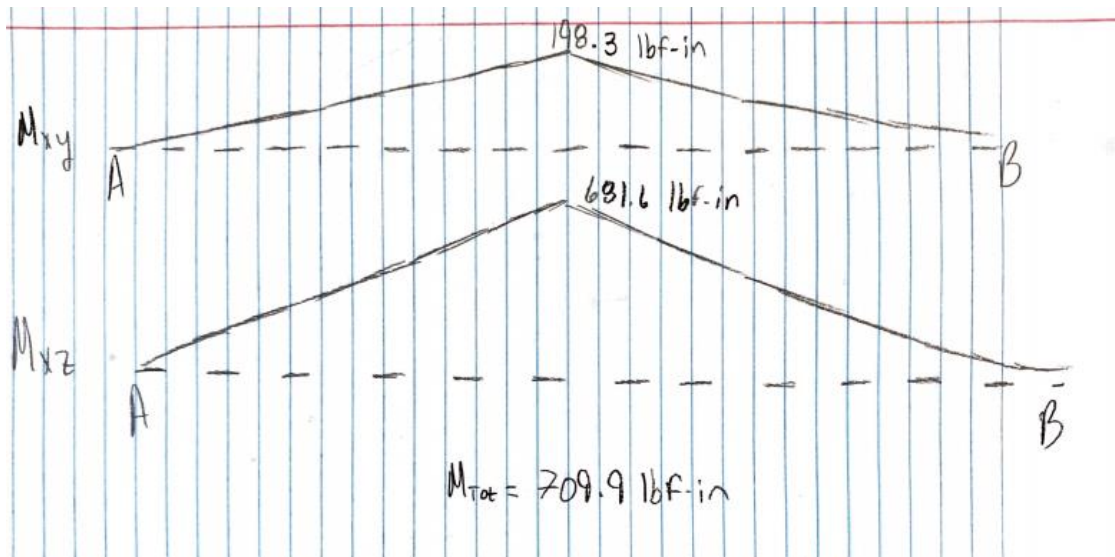

Figure 5: Moment Diagrams

Figure 6 shows the torque acting on the two sides of the gear resting in the middle of the shaft.

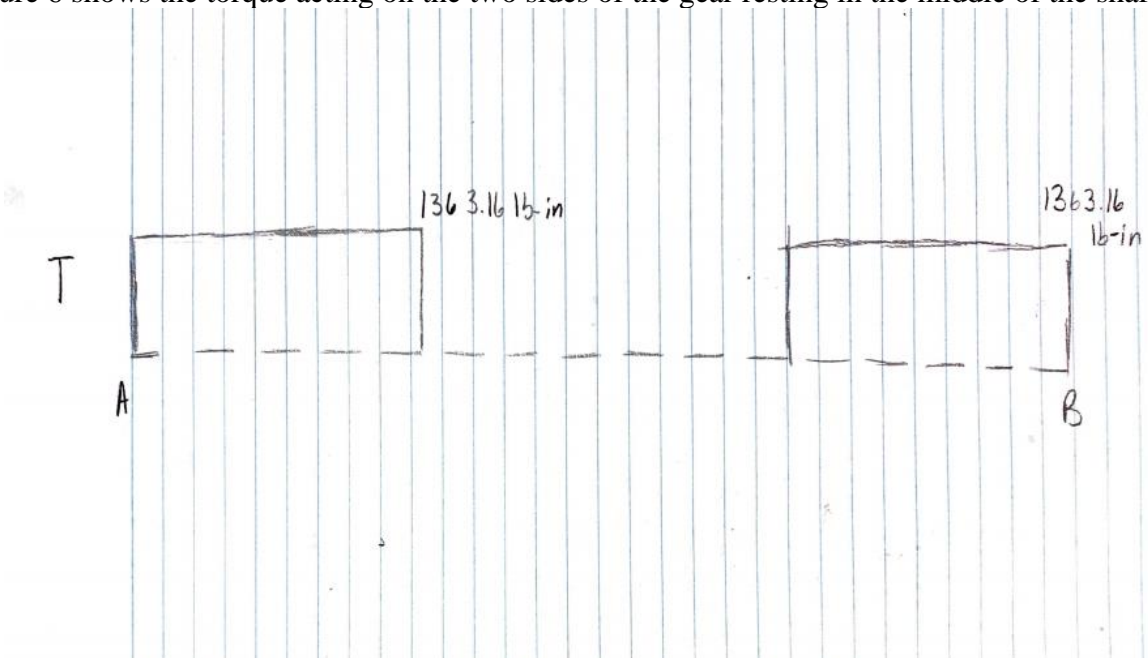
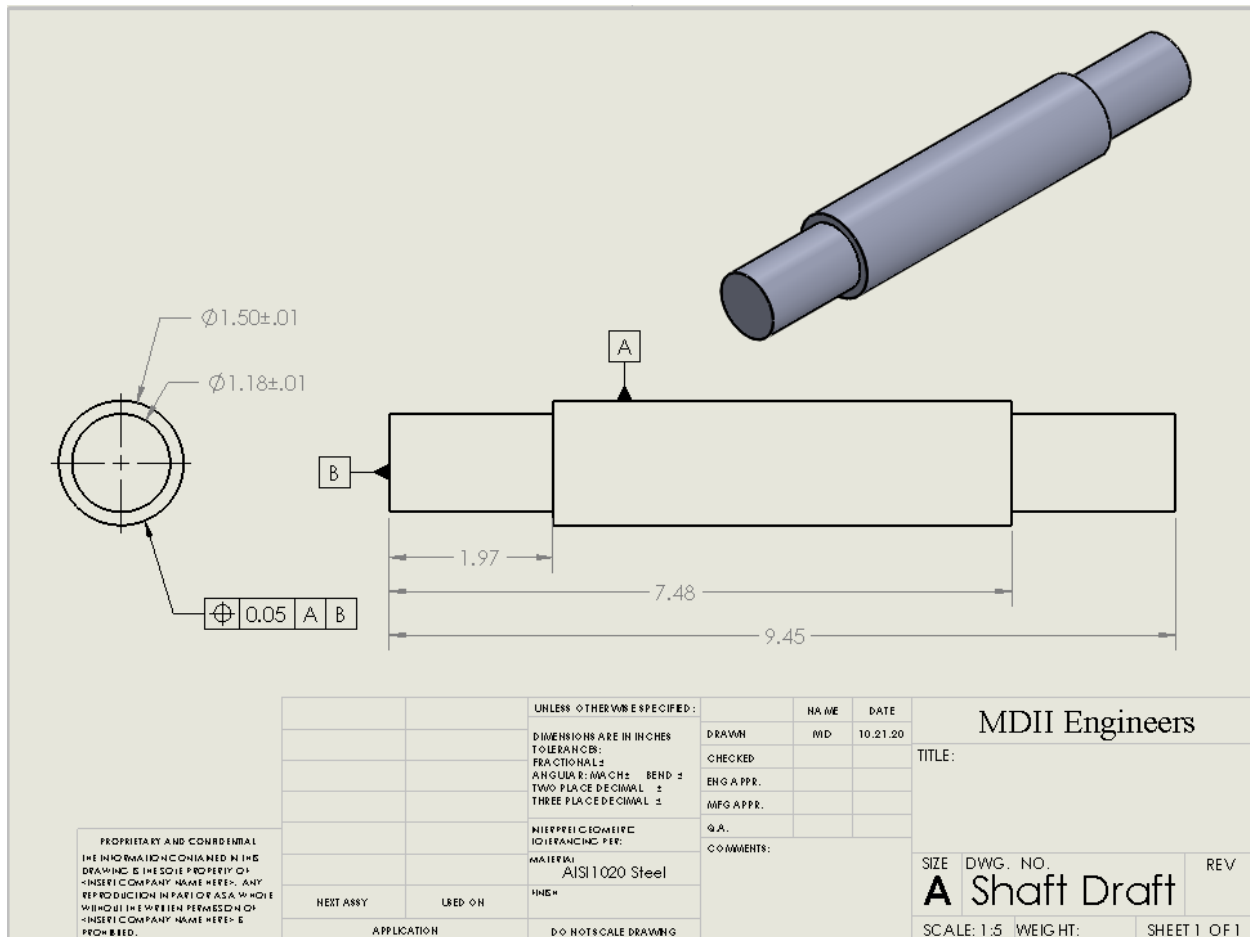

Figure 6: Torque Diagram



Discussion of Results

Using the information in Tables 3-5, the selected worm gear and worm (WB630DL and LW3L, respectively) meet the design requirements. The bending stress is below the allowable bending stress by over 4,000 psi. The actual wear stress of the team’s worm gear mesh is 360.62 psi. This value is less than the allowable stress by over 1,200 psi. The team tested two ways to find if the worm gear mesh was self-locking. Table 13-6 (assuming a pressure angle of 20 degrees) conveys that when the efficiency is between 25.2% and 76.7%, the worm gear mesh is self-locking. The pressure angle of the chosen worm is 14.5 degrees, and the efficiency of the team’s worm gear mesh was 57.22%. Since this number is in between the efficiency percentages for a larger pressure angle, it can be assumed the worm gear mesh is self-locking with the smaller pressure angle. The second way the worm-gear mesh was tested for if it is self-locking was by calculating the tangent of the lead angle [4]. The tangent of the lead angle must be less than the coefficient of friction, $f = 0.04$ [4]. This value was calculated to be 0.038, which is less than the coefficient of friction. The team also assumed a design factor of 1.2 for the calculations.

After calculating the deflection and factor of safety, the shaft was designed to support the worm gear and drum. The factor of safety is a reasonable number that the AISI 1020 steel shaft shown

in Figure 6 can support. The Excel spreadsheet that calculated the deflections shows the ends of the shaft to be deflecting zero inches. All the force diagrams as shown in Figure 2-4 also start and end at a value of zero. This is critical to the design and shows the team completed the analysis correctly. In the free body diagram, an axial force is placed on bearing A. The team will need to place a thrust bearing here to support the axial load while still allowing rotation between the parts. The maximum deflection occurred where the worm gear is placed on the shaft of $-3.26E-6$ inches. This value is magnitudes less than the maximum deflection of 0.010 inches. The shaft designed will be able to support the worm gear and drum.

Conclusion

As shown in Table 5, the worm-gear mesh chosen and analyzed from Rush Gears (WB630DL and LW3L) have an actual bending stress below the allowable bending stress. The team's conclusion is that the worm-gear mesh would not fail under the conditions tabulated above. The team used the tangent of the lead angle to test whether it is less than the coefficient of friction value. With a greater friction coefficient, the worm-gear mesh is confirmed to be self-locking [4]. The analysis performed for the first progress report covered force, bending, and wear while assuming a design factor of 1.2 for the gear teeth. The analysis performed for the second progress report covered shaft design and failure to ensure our teams design would not fail under the constraints given in the problem statement.

A shaft that supports the problem statement's bearing of 1 to 2 was designed. The free body diagram outlines all the forces that will act on the shaft. Shear, moment, and torque diagrams were created to find maximum forces along the shaft. These forces were used to find the factor of safety and deflections. The factor of safety is 5.48 with a maximum deflection occurring on the point load of the worm gear of $3.26E-6$ inches. The AISI 1020 steel shaft will be able to support the worm gear and drum as shown in the results. After carefully looking at feedback provided from previous progress reports, we reviewed the previous gear selections and shaft design to make any adjustments needed. The next step for the team was selecting the bearings on that shaft for a fully supported and working system.

References

[1] Northern Arizona University, "ME 495 – Machine Design II MAJOR COURSE PROJECT," Flagstaff, AZ, 2020.

[2] "3D CAD and Part Search", *Rushgears.com*, 2020. [Online].

Available: https://www.rushgears.com/tech-tools/part-search/gears/type/worm_gear. [Accessed: 07- Oct- 2020].

[3] R. G. Budynas and J. K. Nisbett, *Shigley's Mechanical Engineering Design*, 11th ed. New York, NY: McGraw-Hill Education, 2020.

[4] D. Collins, "Self-locking in worm gears: how does it work and where is it useful?", *Motioncontroltips.com*, 2020. [Online].

Available: <https://www.motioncontroltips.com/when-are-worm-gears-self-locking-and-where-is-this-useful/#:~:text=Self%2Dlocking%20means%20that%20the,back%20driving%20is%20not%20possible.&text=In%20theory%2C%20as%20long%20as,and%20will%20not%20back%20drive>. [Accessed: 07- Oct- 2020].