

Quality Assurance Standard

DESIGN STANDARDS – MECHANICAL ENGINEERING AND INSTALLATIONS

Abstract

This document defines standards for the preparation of all mechanical engineering drawings and all installation drawings for the LHC. It also defines standards for the official CAD 3D models library.

Prepared by :

M. Mottier

EST/ISS

Marcel.Mottier@cern.ch

Checked by :

**LHC Quality Assurance
Working Group**

Approved by :

Paul Faugeras

Deputy to LHC Project
Leader for Quality
Assurance

History of Changes

<i>Rev. No.</i>	<i>Date</i>	<i>Pages</i>	<i>Description of Changes</i>
0.1	1998-03-10		1 st draft
0.2	1998-03-12		Update following QAPWG meeting
0.3	1998-04-16		Update following QAPWG meeting
0.3	1998-06-18		Reviewed by QAPWG- Approved by PLO Deputy for QA.
1.0	1998-06-25		Released
1.1	1999-11-15		Corrected references in section 10
2.0 draft	2000-07-25		Updated to include 3D models in chapter 7
2.0 draft	2000-08-28		Reviewed by QAPWG- Approved by PLO Deputy for QA
2.0	2000-08-30		Released

Table of Contents

1. PURPOSE	4
2. POLICY	4
3. SCOPE.....	4
4. RESPONSIBILITIES	5
5. CERN DRAWING FORMAT.....	5
5.1 DRAWING SIZES	5
5.2 TITLE BLOCK	5
5.3 PARTS LISTS.....	6
5.4 MODIFICATION LIST	7
6. DRAWING PREPARATION WITH EUCLID	7
7. 3D MODEL MANAGEMENT AND STANDARDS	10
7.1 MODEL MANAGEMENT - MODEL REFERENCE LIBRARY.....	10
7.1.1 CO-ORDINATE SYSTEMS	11
7.2 MODEL PREPARATION WITH EUCLID.....	12
7.2.1 MODEL NAMING CONVENTIONS	12
7.2.2 MODIFICATIONS AND REVISION INDEX	13
7.3 MODELS PREPARED WITH CAD SYSTEMS OTHER THAN EUCLID	13
7.4 3D MODEL CONTROL DRAWING	13
8. DRAWINGS PREPARATION WITH AUTOCAD	15
9. ANNEXES	18
10. RELATED DOCUMENTATION	18

1. PURPOSE

To provide standards for:

- All mechanical engineering drawings of the LHC.
- All installation drawings of the LHC.
- All CAD 3D models of the LHC stored in the official model library.

2. POLICY

All mechanical engineering and installation drawings for the LHC project shall be created with a Computer Aided Design (CAD) system. The CAD systems used at CERN for these activities are AutoCAD¹ and Euclid². Pro-Engineer³ is also used for specific applications.

All engineering drawings referenced in a CERN contractual document shall incorporate the appropriate CERN title block. The drawing title and the parts lists shall be written in English only or in English and French.

All engineering drawings shall be stored in the CERN Drawing Directory (CDD) with the relevant descriptive information and identified by a unique drawing number defined in accordance with the CERN Drawing Directory rules as described in document LHC-PM-QA-305.00 "Drawing and 3D Model Management and Control" [1].

All engineering drawings shall be submitted to a review and approval process before being released.

New revisions of released drawings shall be submitted to the same review and approval process as the original drawing.

3D CAD models required for general installation assemblies of LHC systems shall be created with Euclid version 3 and stored in a model library.

3D CAD models required for the exchange of CAD data with CAD systems other than Euclid version 3 shall be stored in the model library in a CAD exchange format as well as the Euclid native format.

Prior to their release and transfer to the official model library, 3D CAD models shall be submitted to a review and approval process similar to the review and approval process of drawings.

A drawing shall be prepared for each 3D model in the library. The release of a 3D model in the library is effected by the release of the model's drawing.

3. SCOPE

This standard is applicable to:

- All mechanical engineering drawings of the LHC systems, sub-systems, assemblies, sub-assemblies and parts
- All installation drawings of the LHC. This includes civil engineering drawings and installation drawings for the electrical, fluids, cryogenics, power distribution and ventilation systems.
- All 3D CAD models used for general installation and assemblies of LHC systems.

It does not apply to:

¹ AutoCAD is a registered trademark of Autodesk, Inc.

² Euclid is a registered trademark of Matra Datavision

³ Pro-Engineer is a registered trademark of Parametric Technology Corporation

- Schematic diagrams which are covered by the documents LHC-PM-QA-403.00 "Design Standards – Electrical Schematics Diagrams" [2] and LHC-PM-QA-404.00 "Design Standards – Fluids Schematics Diagrams" [3].
- Drawings produced in Institutes, Contractors and Suppliers, which are covered by document LHC-PM-QA-306.00 "Drawing Process - External Drawings" [4].

4. RESPONSIBILITIES

Managers, Supervisors and Project Engineers (PE) at CERN working on the LHC Project are responsible for:

- Assuring that designers and draughtsman are aware of and understand the procedures described in the present document.
- Assuring that these design standards are fully implemented in their design.
- Assuring that non-CERN staff assigned to CAD design and drafting activity is suitably trained and has been informed of CERN practices before starting work.

Every designer and draughtsman is responsible for producing drawings in compliance with these design standards.

5. CERN DRAWING FORMAT

5.1 DRAWING SIZES

All drawings shall be made on one of the following International Organization for Standardization (ISO) standard sizes:

Horizontal	A0 (1188 x 840 mm)
	A1 (840 x 594 mm)
	A2 (594 x 420 mm)
	A3 (420 x 297 mm)
Vertical	A4 (297 x 210 mm)

5.2 TITLE BLOCK

The title block of each drawing has to be filled in with the following data:

TITLE	- line 1: name of the assembly to which the drawing relates, in English - line 2: name of the part or sub-assembly, in English - line 3: translation of the 1st line in French, or left blank - line 4: translation of the 2nd line in French, or left blank
DRAWING NUMBER	As described in [1]
QA CATEGORY	The code of the quality assurance category (1 char)
DRAWING SIZE	The 2nd digit of the size (3 for size A3)
REVISION INDEX	The 2nd letter of the revision index
AUTHOR	The author's initial and surname
DATE	The date of creation of the drawing in ISO format (yyyy-mm-dd)
SCALE	The scale(s) of the drawing views in the form 1:5

ENS/ASS The assembly drawing number to which the part or sub-assembly belongs

S.ENS/S.ASS The sub-assembly drawing number to which the part or sub-assembly belongs

EQUIPMENT CODE The full description of the code

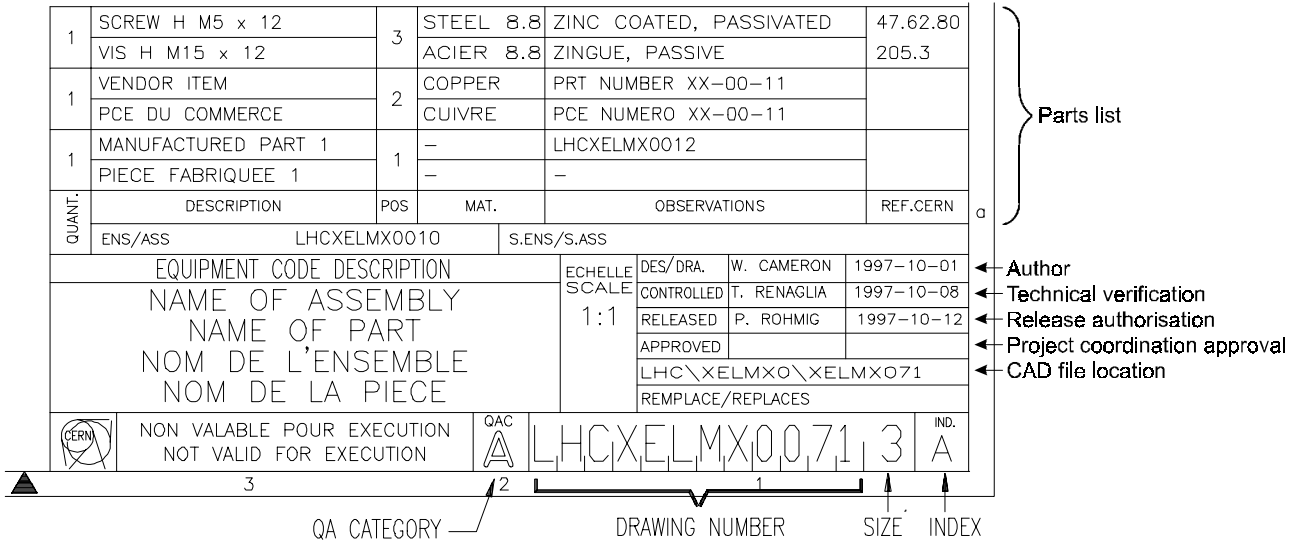

Figure 1 - CERN Drawings Title Block

5.3 PARTS LISTS

Parts lists abbreviated headings have the following meaning:

- QUANT. The number of parts necessary for one assembly.
- DESCRIPTION See below.
- POS. The part reference number on the drawing.
- MAT. The parts material for vendor and CERN stores items.
This shall not be filled in for manufactured parts.
- OBSERVATIONS See below.
- REF.CERN The reference number for CERN stores items.

Parts lists are lists of parts and materials required for manufacturing the assembly shown on the drawing.

Parts lists are integral to the drawing.

Parts lists are created in English or in English and French. If a parts lists is in both languages, the 1st (top) line shall be in English and the 2nd (bottom) in French.

Manufactured items in the parts list are referenced by the part's name in the *DESCRIPTION* box and the part's drawing number in the *OBSERVATION* box. Drawing size and drawing revision index shall not be included.

Vendor items are referenced by their description in the *DESCRIPTION* box. The *OBSERVATION* box may be used for supplementary information.

Whenever an ISO standard description exists for purchased items it shall be used.

Parts obtained from the CERN stores may be referenced by the CERN SCSEM code in the REF. CERN box.

5.4 MODIFICATION LIST

A new line has to be added to the modification list of drawings for each revision, with the following data:

- INDEX The 2nd letter of the revision index.
- DATE Date of the modification
- NAME Initial and surname of the author of the modification
- ZONE The location of the modification (1 char + 1 digit)
- MODIFICATION The Engineering Change Request (ECR) [5] number of the modification or a text describing the modification(s)

A	1998-02-03	J.F. MICHAUD	B 5	ECR Number or Description of the modification
IND.	DATE	NOM/NAME	ZONE	MODIFICATION
	7		6	5

Figure 2 - Drawing Modification List

6. DRAWING PREPARATION WITH EUCLID

The Euclid database for the LHC is divided in PROJECTS corresponding to the LHC main systems and activities. Each PROJECT is made up of a number of SUB-PROJECTS corresponding to products or activities in the system.

The names of PROJECTS is formed of the 3 characters LHC completed by a 4th characters which is the LHC System prefix. The list of LHC PROJECTS is given below:

- LHCA** Acceleration, RF and dampers
- LHCB** Beam instrumentation
- LHCC** Communications and controls
- LHCD** DC Powering
- LHCE** Electrical distribution
- LHCF** Fluids (demineralized water excluded)
- LHCG** Geodesy and geometry
- LHCH** Mechanics, supports and handling
- LHCI** Injection and transfer lines
- LHCJ** Infrastructure
- LHCK** Civil engineering
- LHCL** Layouts
- LHCM** Magnetic elements
- LHCN** Particle sources
- LHCP** Personnel safety
- LHCQ** Cryogenics
- LHCR** Power converters
- LHCS** General safety
- LHCT** Targets, dumps and collimators

- LHCU** Ventilation and air conditioning
- LHCV** Vacuum
- LHCW** Demineralized water
- LHCX** Experiments
- LHCY** Access systems
- LHCZ** Electrostatic systems

The name of a SUB-PROJECT is formed of:

- the equipment code of the product or activities
- one "underscore"
- an abbreviated description of the product or activity (7 chars)
- a location code identifying the Euclid database site of the PROJECT

EQUIPMENT						DESCRIPTION					DB SITE				

A single user code shall be used in any given sub-project. User codes are formed of:

- one character corresponding to the LHC main system prefix
- three digits attributed sequentially in the project

To guarantee that Euclid objects names are unique throughout the full database, strict naming conventions have to be respected. This is achieved by building in every object name the unique user code of the sub-project. The Euclid software itself will prevent duplication of names in the sub-project. Object names are formed of:

- the sub-project user code (4 chars)
- a sequential number (4 digits)
- two characters identifying the object type (2 chars)

USER CODE				SEQUENTIAL NUMBER				TYPE	

Object types are one of the following:

MQ	model
PL	drawing
VU	view

The CERN developed Euclid application DOC-MRP shall be used for the storage of all objects in the Euclid database. This application automatically provides object names respecting the naming convention described here.

Mechanical engineering and related drawings shall be created in millimetres. Civil engineering, layouts and installation drawings may be created in meters.

For each sub-project a workspace is defined and stored in an initialisation procedure. All designers working in the same sub-project shall use the same initialisation procedure.

3D modelling of an LHC component is carried-out in a local co-ordinates system specific to that component. These components local co-ordinates systems can be related to the LHC global system to create assemblies and layouts. The local co-ordinates of a component is defined as:

- X directed towards the LHC centre
- Y coincident with the LHC mechanical axis and directed from left to right for an observer standing at the LHC centre
- Z normal to the plane of the LHC
- X,Y lie in the plane of the LHC

The origin of the local co-ordinate system of an LHC component is located on the interconnection plane at the upstream end of the component.

In the top view on the screen (the view from above) the screen horizontal is Y directed from left to right and the screen vertical is X directed from top to bottom. It should be noted that this is not the current default axis system of Euclid.

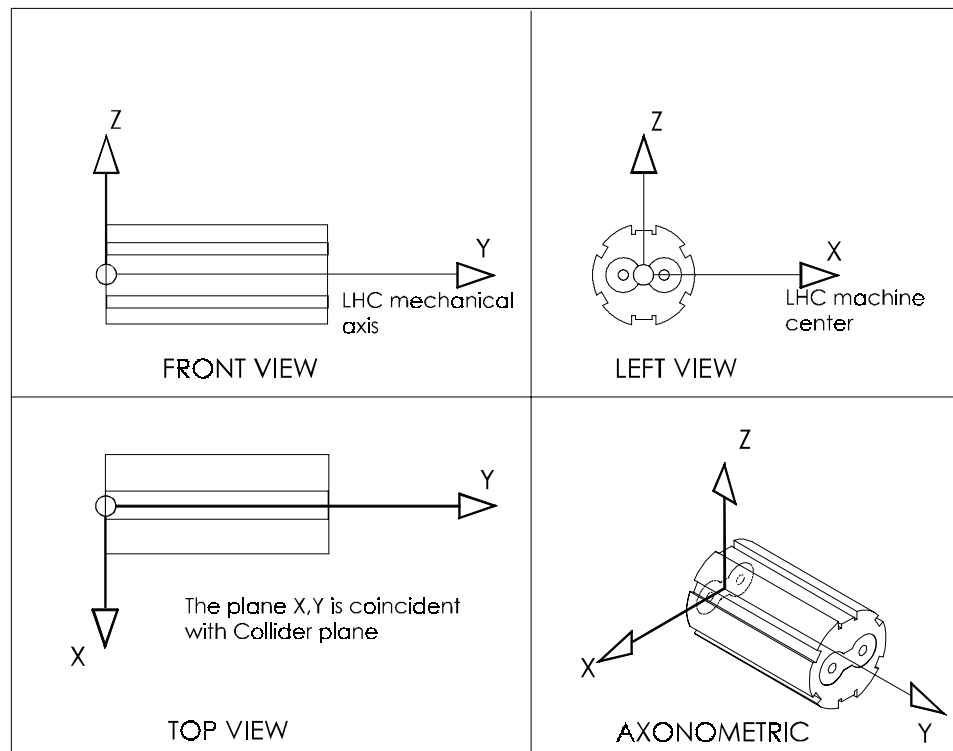

Figure 3 - Euclid co-ordinates system for LHC

Dimensions, texts and notes shall be made using the DIMEN22B dimension table stored in standard 4000 on the CERN site.

The line types, thickness and colours that shall be used for drawings are given in table 1.

Line type	Description	Use	Thickness	Colour
A1,A2	Continuous, thick	Apparent object contours	0.50	Cyan
B1	Continuous, medium	Fictitious lines	0.25	Green
B2,B3,B4	Continuous, medium	Phantom, dimensions, leader	0.25	Yellow
B5	Continuous, thin	Cross-hatching	0.18	Yellow
B6	Continuous, thin	Pivoted sections	0.25	Blue
B7	Continuous, thin	Short axis	0.25	Red
C1	Dotted, medium	Broken sections	0.25	Vert
F1,F2	Dotted, medium	Hidden lines	0.35	Yellow
G1,G2,G3	Mixed, thin	Axis, planes, trajectories	0.25	
H1	Mixed, thin/thick	Section/cut planes	0.25	Green
J1	Mixed, thick	Indication of surfaces & lines with special specifications	0.50	Yellow
K1,K2,K3, K4,K5	Dashed with double dots	Neighbouring objects, centre of gravity, etc.	0.25	Magenta

Table 1 : Euclid line types

7. 3D MODEL MANAGEMENT AND STANDARDS

This chapter describes the processes, practices and standards associated with the preparation and archiving of models used for general installation assemblies, for transport and installation simulations, and for any other studies where the availability of 3D models is necessary.

7.1 MODEL MANAGEMENT - MODEL REFERENCE LIBRARY

All 3D models shall be stored in the reference model library. This library is a protected area of the Euclid database. Before models are stored in the reference library, they shall be reviewed and approved as described [1].

New revisions of 3D models in the reference library shall be submitted to the same review and approval as the original model.

The reference library comprises different zones, each zone with its specific co-ordinate system:

- The component zone with a co-ordinate system associated to the component
- A number of assembly zones, with a co-ordinate system associated to that particular assembly, or to a building or to a geographical area. An assembly zone shall not be larger than 2'000m in diameter.

The component zone is used as a switchyard from which the up-to-date version of each model is dispatched to the different assembly zones. All revisions of a model are kept in the component zone, but only the latest revision is dispatched and kept in each of the assembly zones.

Copies of the models in viewing formats, VVML⁴ and WRL⁵, are created when models are released. They are accessible via the WWW. Another copy is transferred to the database of the dynamic simulation package DYNAMO⁶.

The process is shown schematically in figure 4 below. Processing is done automatically by the Euclid application program CDD.

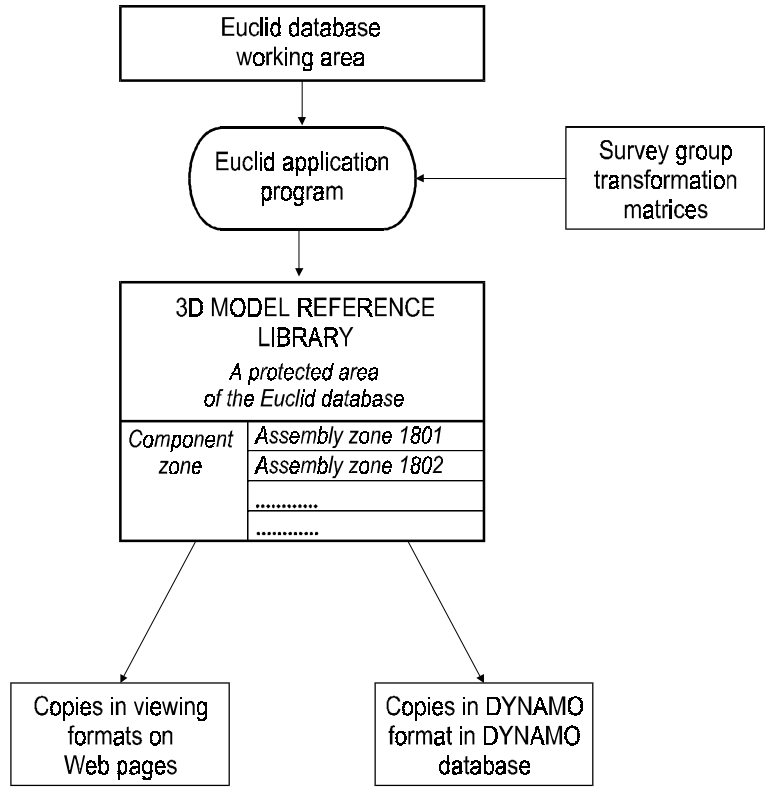

Figure 4 - 3D Models Database Organisation and Archiving Process

7.1.1 CO-ORDINATE SYSTEMS

The origin of the local co-ordinate system of an LHC component is located on the interconnection plane at the upstream end of the component (see figure 3).

When the model is released, it is transferred to the component zone and copies are automatically dispatched to the different assembly zones where the model is used.

The geometrical transformations used to dispatch the model from the component zone to the assembly zones are based on data supplied by CERN's Survey group.

The co-ordinate systems are identified by a four digit code. Codes are proposed by design offices and are introduced in the 3D model management application by the EST CAD support service, after verification of consistency with survey data.

⁴ The Virtual Reality Modeling Language - International Standard ISO/IEC 14772-1:1997.

⁵ WorkView Language - The dedicated language used by the Workview application of DeltaConcept.

⁶ DYNAMO is a registered trademark of Tecnomatix.

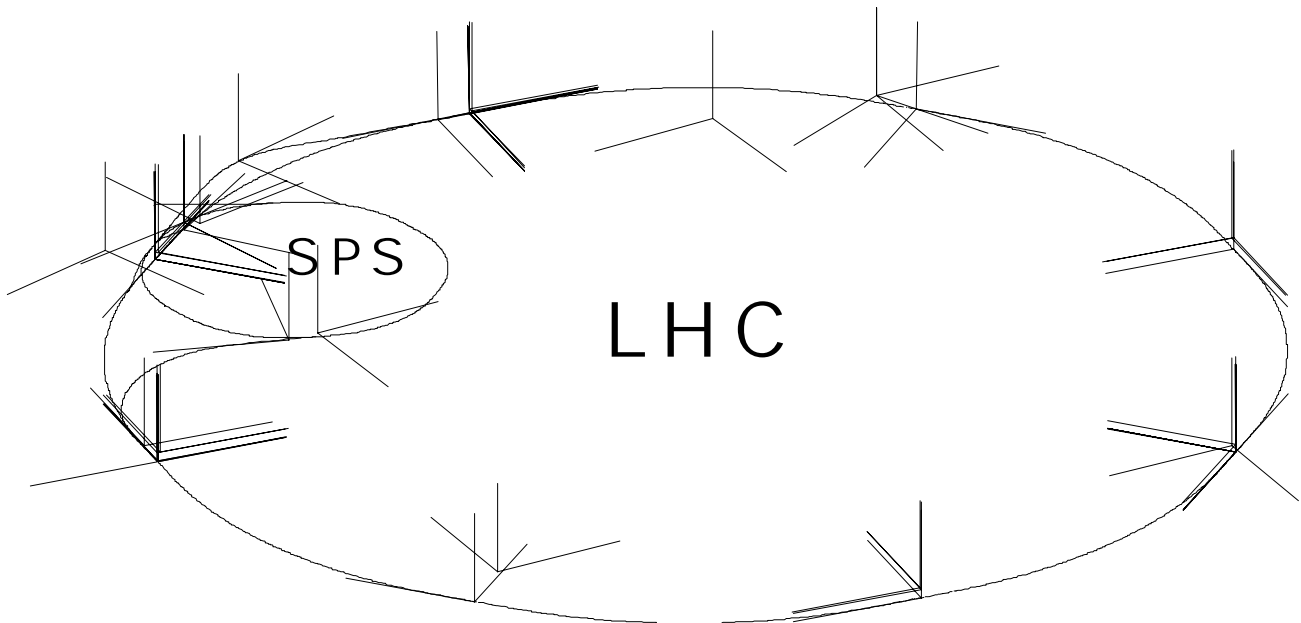

Figure 5 - Assembly Co-ordinate Systems Used around LHC and SPS

The full list of assembly co-ordinate systems is available through the Euclid application READSTD. An extract is shown below.

<i>ASSEMBLY_ZONE</i>	<i>CODE</i>	<i>ORIGIN</i>
POINT 18:	1187	IC LQ CENTRAL STRING2 POINT 8

7.2 MODEL PREPARATION WITH EUCLID

Models shall be constructed keeping in mind the necessity to keep the CAD data structure as small as possible, consistent with the intended use of the model. The data structure size of a model shall not be greater than 32'000 points and 32'000 links.

7.2.1 MODEL NAMING CONVENTIONS

Model names in the reference library are 10 alphanumeric characters long. The first 9 alphanumeric characters are identical to the last 9 characters/digits of the model's control drawing number. The 10th digit has 2 different uses:

- In the component zone it is used as a revision index letter. It corresponds to the revision index of the control drawing.
- In the assembly zones it is used to identify different occurrences of the same model in a particular assembly.

PROJECT CODE	EQUIPMENT CODE	SEQUENTIAL NUMBER
L H C		

CONTROL DRAWING NUMBER

EQUIPMENT CODE	SEQUENTIAL NUMBER	REVISION INDEX
		▼

MODEL NAME IN COMPONENT ZONE

EQUIPMENT CODE	SEQUENTIAL NUMBER	OCCURENCE
		▼

MODEL NAME IN ASSEMBLY ZONES

Example - The external jacks of the LHC dipole:

LHCHQB_P0009 Control drawing number

HQB_P0009 Model name in the component zone of the library

HQB_P00091 Model name of the first set of jacks in the half-cell assembly zone

HQB_P00092 Model name of the second set of jacks in the half-cell assembly zone

HQB_P00093 Model name of the third set of jacks in the half-cell assembly zone

7.2.2 MODIFICATIONS AND REVISION INDEX

When a new revision of a model is released, the modified model, with its new name, is transferred to the component zone. From there it is dispatched to the assembly zone where it replaces the previous revision.

The successive revisions are all kept in the component zone of the reference library but only the latest version is kept in the assembly zones.

Example - Evolution of the external jacks of the LHC dipole

HQB_P0009 The first release of the model in the component zone of the library

HQB_P0009A The second release of the model in the component zone of the library

HQB_P00091 The second release of the model in the half-cell assembly zone

7.3 MODELS PREPARED WITH CAD SYSTEMS OTHER THAN EUCLID

3D models prepared with a CAD system other than Euclid shall be converted to the Euclid data format and stored in the Euclid database. They shall then be processed as Euclid models.

7.4 3D MODEL CONTROL DRAWING

The purpose and use of 3D models control drawings is described in document LHC-PM-QA-305.00 "Drawing and 3D Model Management and Control" [1]. The standards applicable to 3D model control drawings are the same as those for all Euclid drawings. In addition, the title block of control drawings shall include the following information in the OBSERVATIONS column of the first item of the parts list:

- The keyword SEN2STD indicating a 3D model control drawing.
- A code identifying the co-ordinate system in which the 3D model is represented.

- The CAD name of the 3D model to transfer to the reference library.

The separator between the keyword and the co-ordinate code is a semi-column (:), the separator between the co-ordinate code and the CAD name is a comma (,).

An example is shown in figure 6 below.

				SEND2STD:1903,H0032038MQ	
QUANT	DESCRIPTION	POS	MAT.	OBSERVATIONS	REF.CERN
	ENS./ASS.			S.ENS/S.ASS.	
	LHC CRYO - DIPOLE SUPPORT SYSTEM - EXTERNAL JACKS			ECHELLE SCALE	DES/DRA. T RENAGLIA 2000-03-28
	EXTERNAL JACKS - VERINS EXTERNES -			/	CONTROLLED
					RELEASED
					APPROVED
					LHC,HQBAA_JACK_DI,H003,H0032039PL
				REPLACE/REPLACES	
	NON VALABLE POUR EXECUTION NOT VALID FOR EXECUTION		OAC -	LHCHQB_P0009	SIZE 3
3			2	1	

Figure 6 - Control Drawing Title Block

8. DRAWINGS PREPARATION WITH AUTOCAD

The AutoCAD file naming and directory structure for the LHC is based on the drawing numbering system described in [1]. The directory structure has 2 levels:

- The top directory, named LHC
- Sub-directories, named with the concatenation of the equipment code and the number's first digit.

The file name is composed of the equipment code concatenated with the last 3 digits of the number. The drawing files shall have the extension DWG.

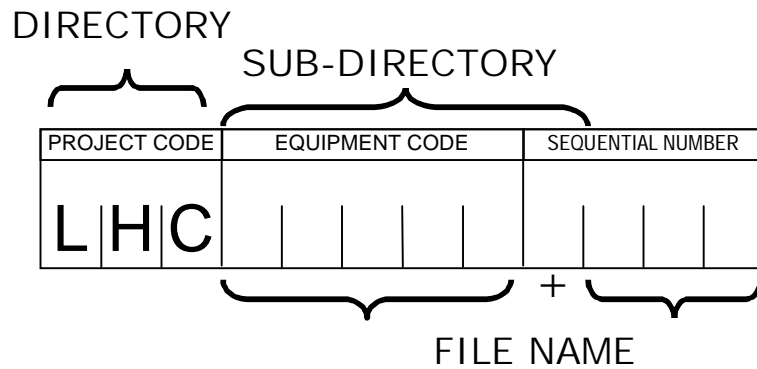

For example the full path for drawing number LHCXELMX8002 would be:
 LHC/XELMX8/XELMX002.DWG

Mechanical engineering and related drawings are created in millimetres. All drawings shall be created using the predefined CERN prototype drawing which initialises layers, linetypes, text and dimension styles. Dimensions shall be created using the predefined CERN dimension style.

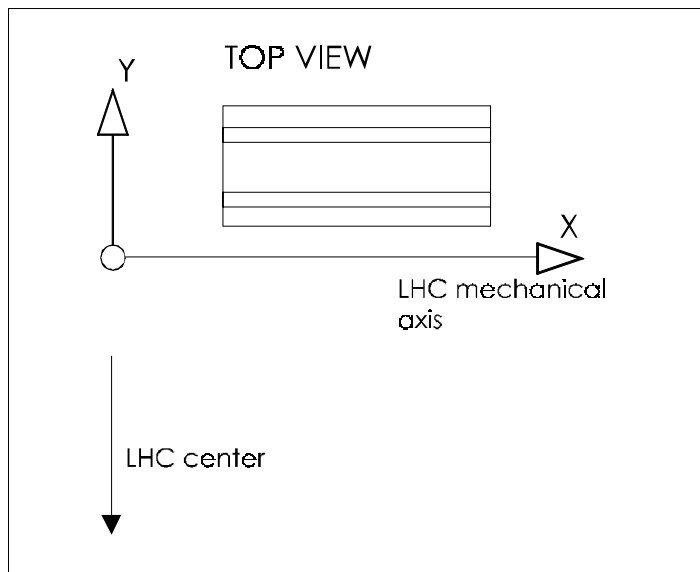

Figure 7 - AutoCAD Coordinates System for LHC

Drafting of an LHC component is carried-out in the AutoCAD World co-ordinate system. Drawings shall be saved with this World co-ordinate system as the current co-ordinate system. In the top view (the view from above) X is parallel with the LHC mechanical axis and directed from left to right for an observer standing at the LHC centre; in this view Y is directed away from the LHC centre.

Layer Assignment:

Layers shall be descriptively named according to Table 2.

Layer 0, the floating layer, is unique and shall stand by itself. Layer 0 shall be used for drawing symbols only. Reusable symbols drawn on layer 0 shall use "BYLAYER" colour and line type defaults where the symbol's elements should inherit new characteristics when inserted in another drawing.

Layer names should be limited to eight characters where practical.

Layer	Description/Purpose	Pen
0 (zero) ¹	AutoCAD floating layer, symbol creation	0.25mm
25	0.25mm lines	0.25mm
25-10	0.25mm lines, for 1:10 scale layouts	0.25mm
25-50	0.25mm lines, for 1:50 scale layouts	0.25mm
35	0.35mm lines	0.35mm
35-10	0.35mm lines, for 1:10 scale layouts	0.35mm
35-50	0.35mm lines, for 1:50 scale layouts	0.35mm
35TEXTE	0.35mm text	0.35mm
50	0.50 lines	0.50mm
50TEXTE	0.50 text	0.50mm
70	0.70 lines	0.70mm
70TEXTE	0.70 text	0.70mm
AXE	Centre lines	0.25mm
AXE-10	Centre lines, for 1:10 scale layouts	0.25mm
AXE-50	Centre lines, for 1:50 scale layouts	0.25mm
AXECOURT	Centre lines, line type scale AXE / 2	0.25mm
CACHE	Hidden lines	0.35mm
CONSTRUCTION ²	Construction lines, comments	0.35mm
COTES	Dimension	0.35mm
HACHURES	Crosshatching	0.25mm
PIECEVOISINE	Adjacent parts in an assembly	0.35mm
TEXTE-10	Text, for 1:10 scale layouts	0.35mm
TEXTE-2	Text, for 1:2 scale	0.50mm
TEXTE-50	Text, for 1:50 scale layouts	0.25mm
\$CARTOUCHE	Reserved for use by sheet frame application	0.25mm
\$TITRE	Reserved for use by sheet frame application	0.25mm
DEFPOINTS	Dimension defpoints, non-printing text	N/A ³

¹Layers with names other than those defined in table 1 are considered additional object layers.

²The layers 0 (zero) and Construction should not appear on final hard copy output, and therefore should be frozen during plotting.

³The "DEFPOINTS" layer does not plot by default, so no Pen is associated with this layer. Notes, graphic entities and instructions can be placed on this layer for the benefit of the user, and WILL NOT appear on the hard copy output.

Table 2: Layers Names

Colour assignments shall be explicitly defined for named layers (Reference Table 2). Entity colour assignments shall be set to the "BYLAYER" condition on all layers for plotting of elements with the correct line widths.

Layer name	Colour
0 (zero)	white
25	white
25-10	white
25-50	white
35	yellow
35-10	yellow
35-50	yellow
35TEXTE	yellow
50	red
50TEXTE	red
70	cyan
70TEXTE	cyan
AXE	green
AXE-10	green
AXE-50	green
AXECOURT	green
CACHE	yellow
CONSTRUCTION	magenta
COTES	yellow
HACHURES	white
PIECEVOISINE	magenta
TEXTE-10	yellow
TEXTE-2	red
TEXTE-50	green
\$CARTOUCHE	white
\$TITRE	white
DEFPOINTS	user defined

Table 3: Colour Assignment

Line Type Assignment:

- Line types shall be explicitly defined for layers. Entities shall be drawn with a linetype assignment of "BYLAYER" or explicitly defined as per the naming conventions outlined in Table 4.
- No special line types shall be created by deleting portions of a continuous line. New line types must use names such as CENTERxx, HIDDENxx, etc., with 'xx' representing some new suffix, e.g. '2' (half scale) or 'X2' (double scale).

Line type	Normal Layers	Pen
Axes	Axe, Axe-10, Axe-50	0.25mm
Tirept	Axecourt	0.25mm
Cache	Cache	0.35
Fantome	Piecevoisine	0.35
Continous	All Others	0.25, 0.35, 0.50, 0.70mm

Table 4: Line Type Assignment

Font and Shape Files:

When defining a text style, the name of the font file shall not include the full directory path.

Example:

For a text style using the font romans.shx, the name of the font shall be defined as romans.shx and not as C:\acad\fonts\ romans.shx.

Only fonts and shape files supplied with the standard AutoCAD installation shall be used. Fonts and shape files supplied with add-on applications shall not be used.

9. ANNEXES

A.1 CERN's mechanical engineering and installation drawing format

10. RELATED DOCUMENTATION

[1] LHC-PM-QA-305.00	Drawing and 3D Model Management and Control
[2] LHC-PM-QA-403.00	Design Standards – Electrical Schematics Diagrams
[3] LHC-PM-QA-404.00	Design Standards – Fluids Schematics Diagrams
[4] LHC-PM-QA-306.00	Drawing Process – External Drawings
[5] LHC-PM-QA-304.00	Configuration Management-Change Process and Control

