



Organic Modeling for Jewelry Design with T-Splines and Rhino® 4



Designing an Earring

Juan Santocono
Industrial Design
Universidad de Buenos Aires, Argentina

Matt Sederberg
T-Splines, Inc.

© Copyright 2008 T-Splines, Inc.



Designing freeform objects can be difficult when working with traditional CAD software. **T-Splines** and **Rhino 4** offer an easy way to create smooth, gap-free freeform models for jewelry design.

The best way to read this tutorial about how to model an earring using T-Splines is by looking at the 3D model at the same time. You can follow the model's progress by selecting the different layers in the file. T-Splines for Rhino must also be installed on your computer. Both T-Splines for Rhino and the earring model can be downloaded at www.tsplines.com.

In this tutorial, anything in **Blue** is a Rhino command, while anything in **Red** is a T-Splines command. Type these commands in the command line of Rhino to run them.

1 Mesh

Creating the base mesh

To get the general shape of the earring we will start by creating a **Mesh-torus**, with `VerticalFaces=8` and `AroundFaces=16`.

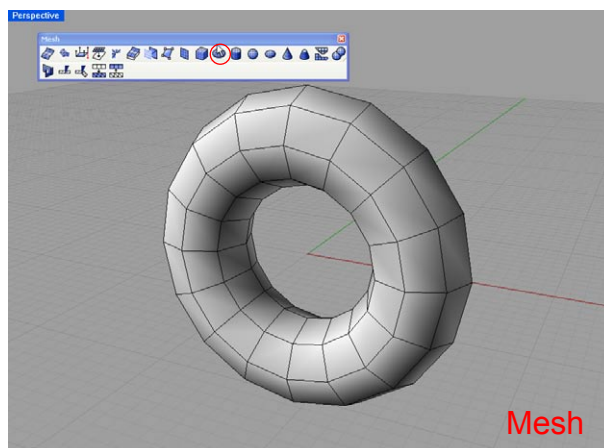

2 T-Spline surface

Converting the mesh

Once we have the mesh torus we just need to convert it to a T-Spline surface.

Use **tsConvert** and select the mesh to perform the conversion. Now we have a T-Spline torus with the same control points as the mesh torus.

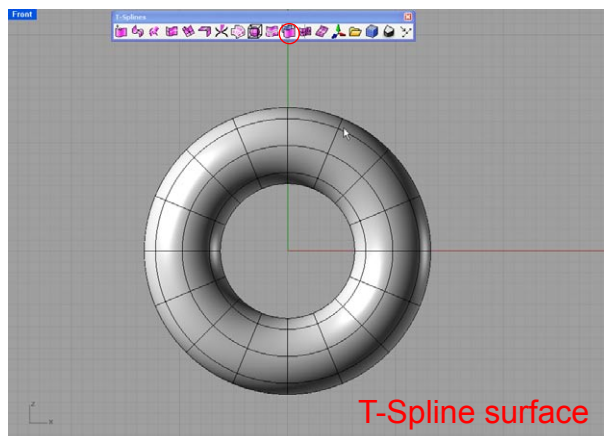



3 T-Spline modification

Extruding faces

The earring design is a sun, so we need to create the sun rays. We will include some long rays and some short rays.

We will create the long rays first. To make these, we will extrude some faces with **tsExtrude**.

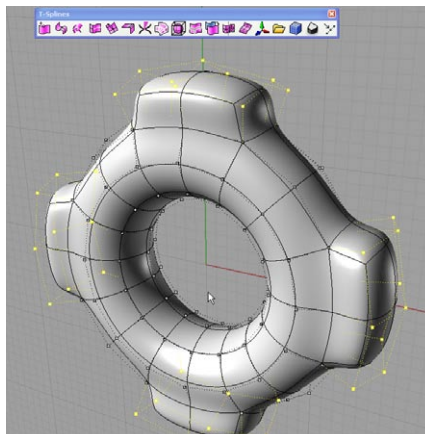
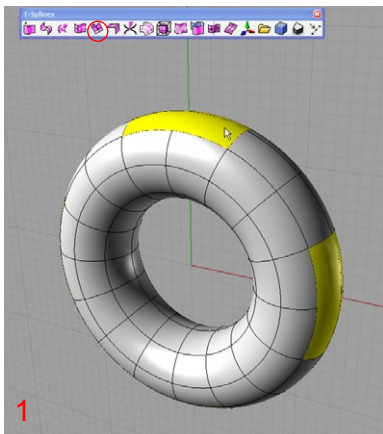

1-Extrude selected faces (yellow) as shown.

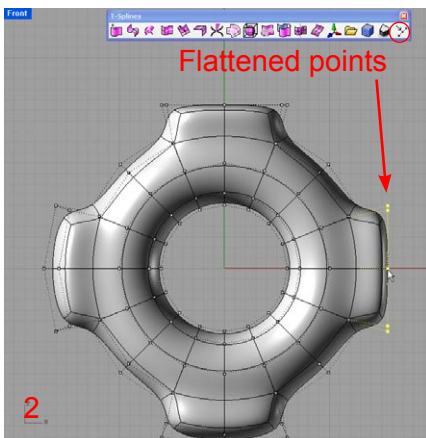

2-In order to get flat rows of control points for the next extrusions, we need to flatten selected points. Use **tsScriptFlattenPoints**. Do this with each of the 4 ray tips separately.

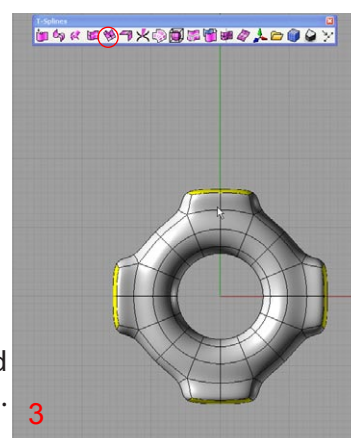

3-Extrude the flattened faces again (**tsExtrude**).

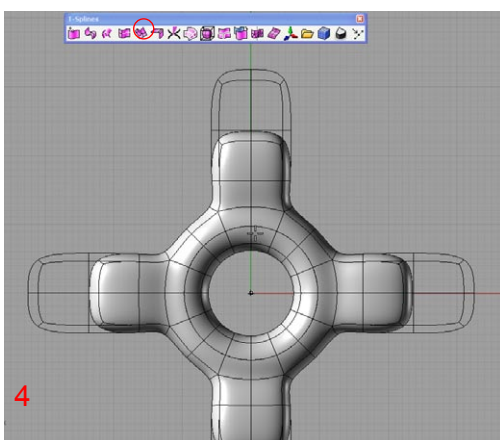

4-Extrude them again.

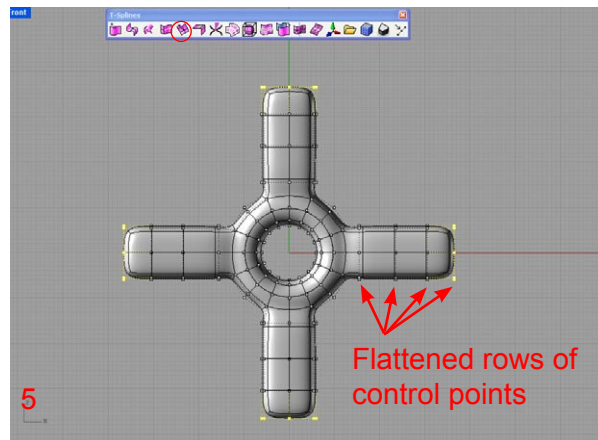

5-Extrude them twice more (a total of four extrusions). This will give us sufficient control points to add details to the rays.



4 T-Splines adjustments

Modifying side profile

Now we will shape the sun rays by using the **FlowAlongCurve** command on the T-Spline control points. First, we need to draw a couple of curves, the base curves (the ones that pass through the control points) and the target curves (these ones represent the new profile).

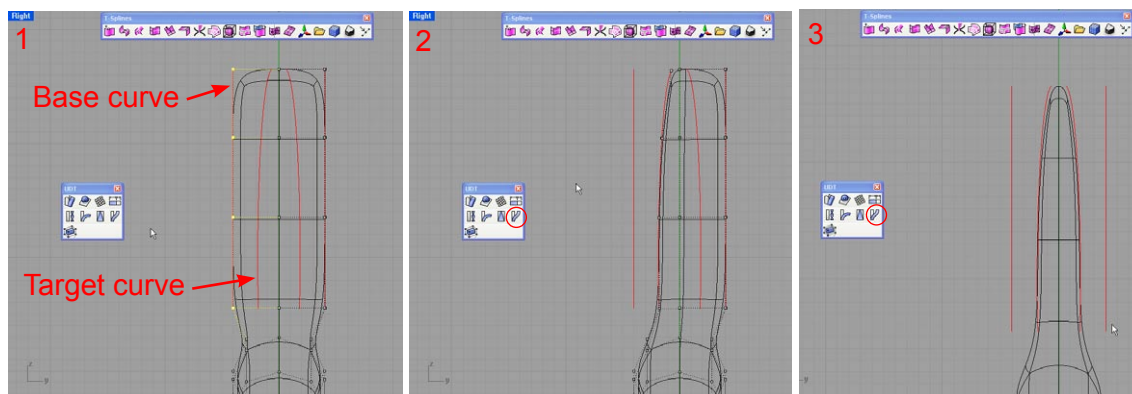

1-Draw the base and target curves for both sides of the sun rays.

2-Use **FlowAlongCurve** on all the left-side control points.

3-Use **FlowAlongCurve** on all the right-side control points.

5 T-Splines adjustments

Modifying front profile

To modify the front profile we are going to do something similar to the previous step, but (for the sake of introducing an alternative workflow) instead of using the flow command we are going to do it manually. Draw some reference curves to provide us with a reference on how we will transform the surface.

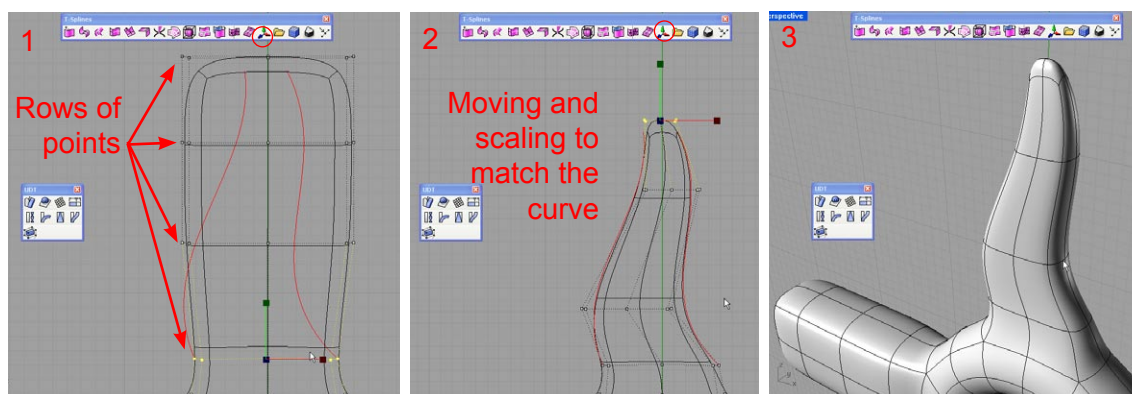

1-Once we have the reference curves, just select the lower row of control points (shown) and use **tsManip** (scale and move) to match the surface profile to the curves.

2-Repeat this process with the four rows of control points. This manual method can give us a decently accurate surface.

3-Now we have the shape that we want on one sun ray.



6 T-Splines adjustments

Modifying details

Now we need to do some further adjustments to get the desired design. First, use **tsManip** to scale (+Y) all the center ray control points, this is to give a concave curvature to the sun rays. Remember to select all the center points of the four rows on each side.

Second, using again de **tsManip** scale this four tip point, this will give us a more smooth tip.

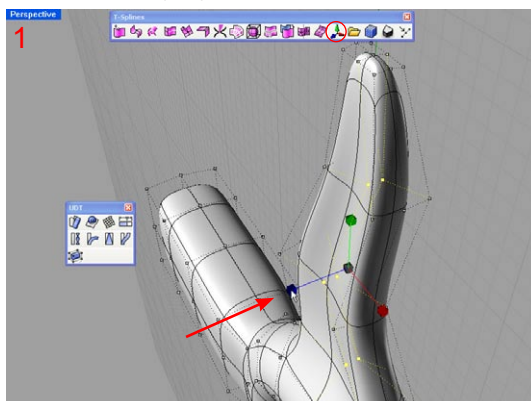

1-Scale center control points +Y.

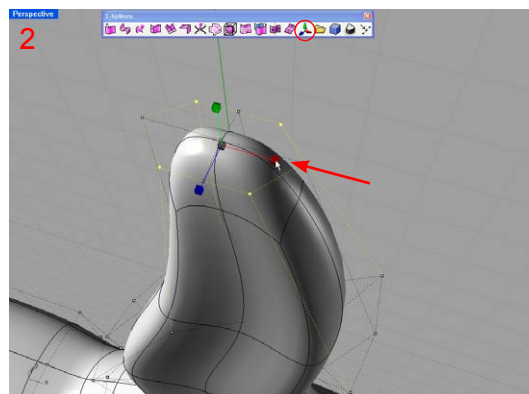

2-Scale tip control points -X.

7 T-Spline adjustments

Copying the rays

We have completed the shape of one sun ray, now we need to shape the others. The design intent is that all four rays should have the same form, so we need to copy our first sun ray shape to the other three rays. Doing this manually would be slow and imperfect. For this reason we will use a method that assures us of the exact same shape on all the rays.

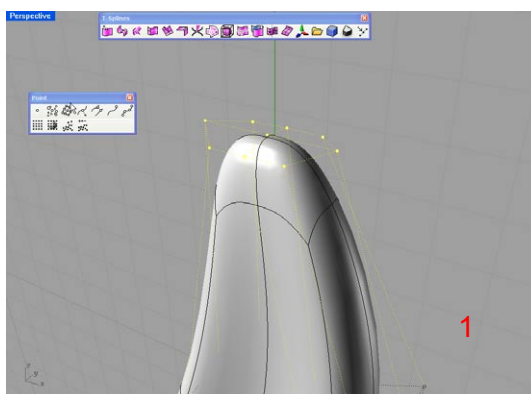

1

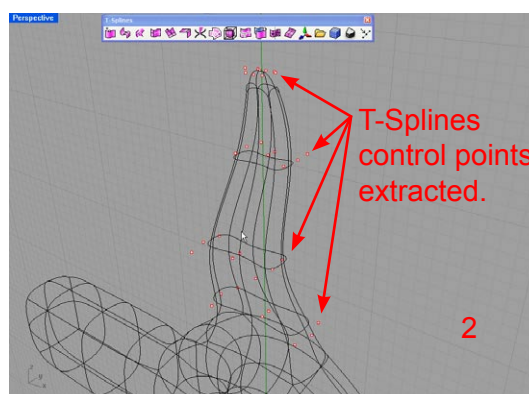

T-Splines control points extracted.

2

- 1-Select all control points of the shaped ray.
- 2-Use **ExtractPt** to make a point from each control point.
- 3-Draw a **Polyline**, snapping to each row of points. This represents the control polygon of the ray surface. Connecting the points is not strictly necessary, but is useful to give a visual understanding of the control polygon.

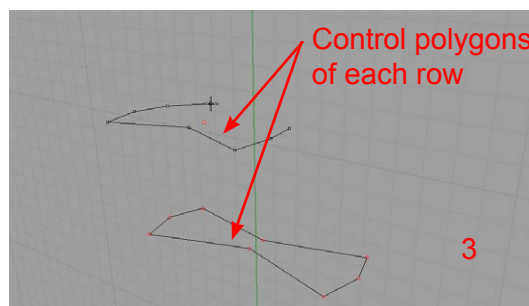

Control polygons of each row

3

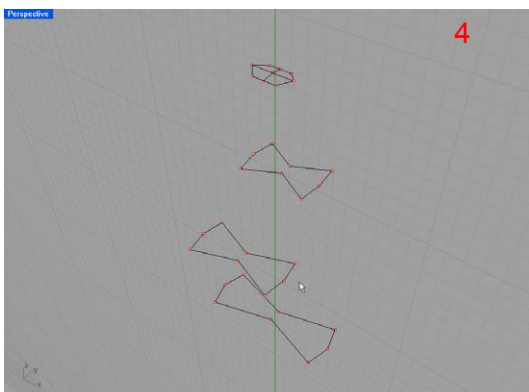

4-Groups of control points from the shaped ray.

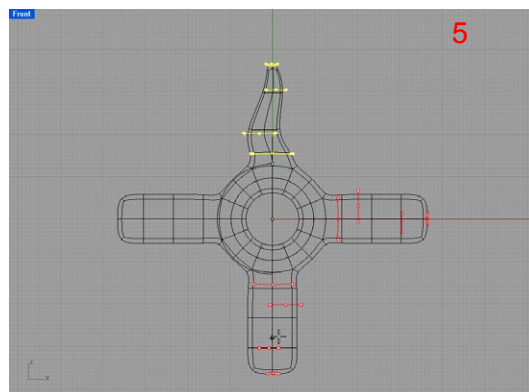

5-Copy these control polygons to each ray. Use **Rotate** (copy on).

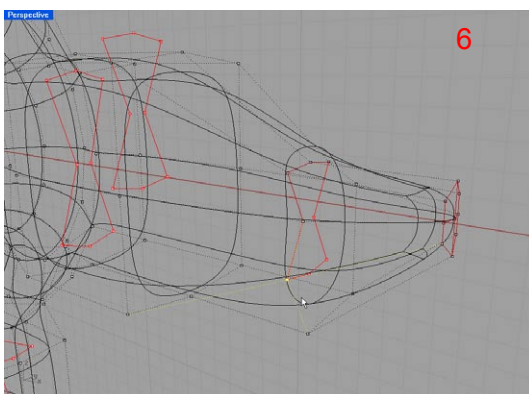

6-Now, using snap (points and ends) move each T-Spline control point on each ray to its corresponding control polygon point from the shaped ray.

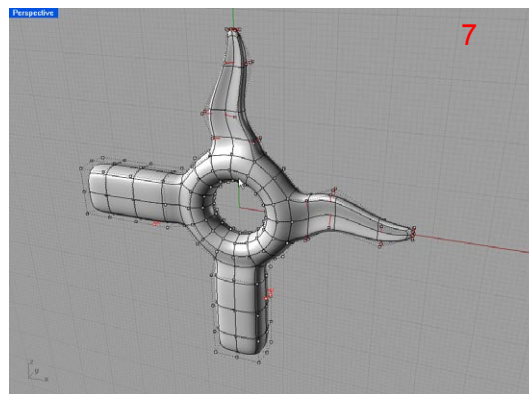

7-Repeat this with each ray until all four are shaped.

This method of copying shapes by snapping to copied control points might seem a little tricky at first sight, but with relatively simple T-Splines shapes it is really fast and insures a symmetric shape.

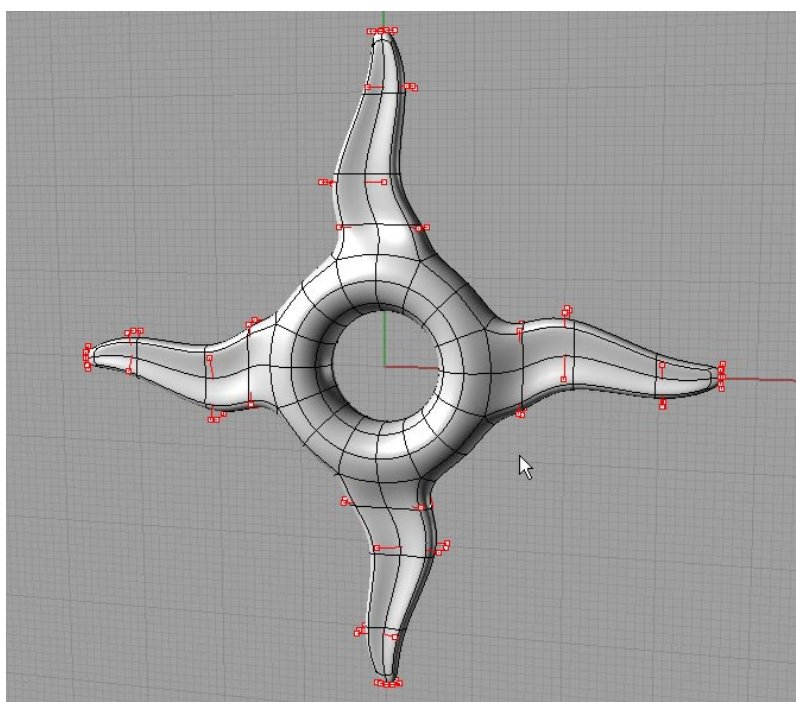



8 T-Splines modification

Extruding small rays

Now we are going to create the shorter rays. For this we will extrude some faces with the **tsExtrude** command.

All of the modeling steps used to create the shorter rays are similar to those used for the longer rays. Just follow the same workflow.

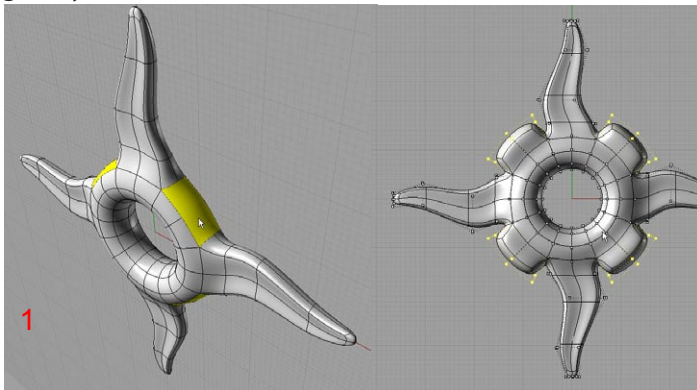

1-**tsExtrude** selected faces.

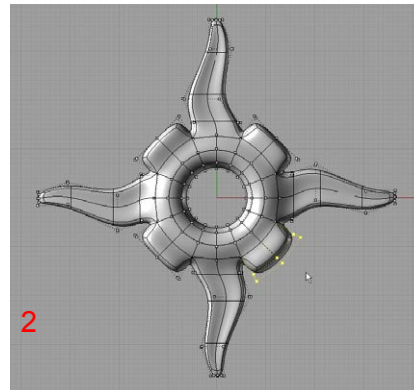

2-Flatten each face's control points (**tsScriptFlattenPoints**).

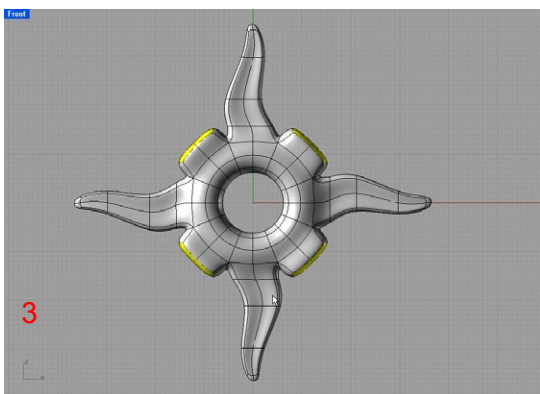

3-**tsExtrude** the flattened faces.

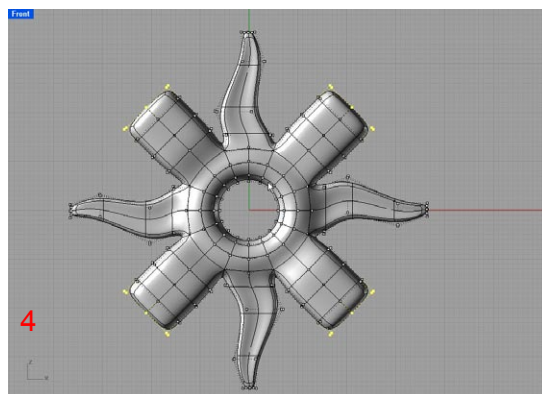

4-**tsExtrude** again and again. Four times total, just like the longer rays

9 T-Splines adjustments

Copying smaller ray shape

Here we are going to use the same method we used on the longer rays, but we'll save time by just copying and scaling the control polygons used for the longer rays and reusing them for the smaller rays. Just copy the control polygons of the longer rays, **rotate** them by 45 degrees, and scale them to be smaller. This will allow all rays, both long and short, to have the same shape.

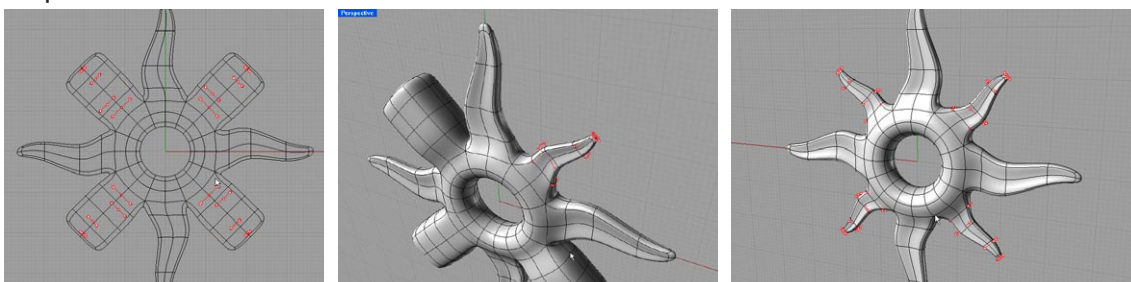



10 T-Splines adjustments

Modifying the center ring

To get the correct design we need to do some adjustments on the center hole. The intention is to have a bigger hole and a sharper edge on the transition between the sun body and the sun rays.

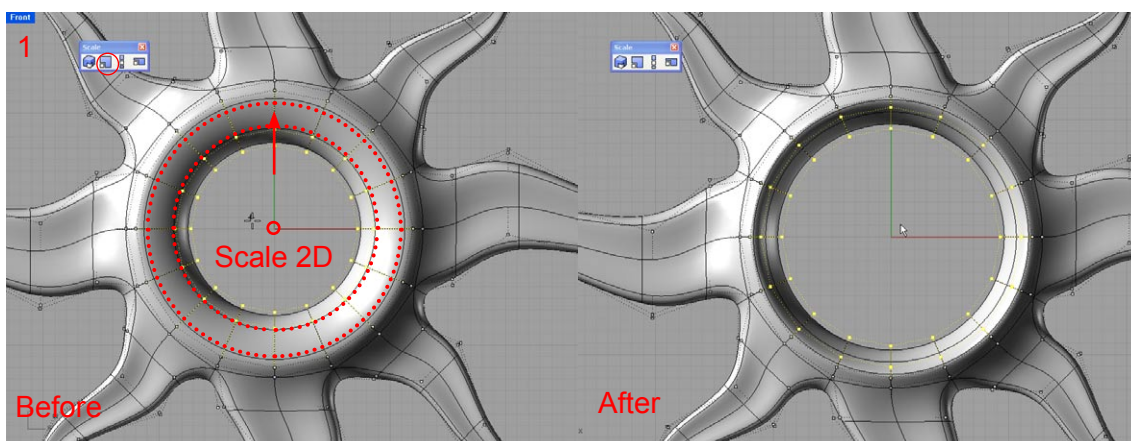

1-Select the control points shown and using `scale2D`, scale them outwards to give the hole a wider diameter and smooth the inner torus curvature. (The origin of the 2D scale is the center (0,0,0).)

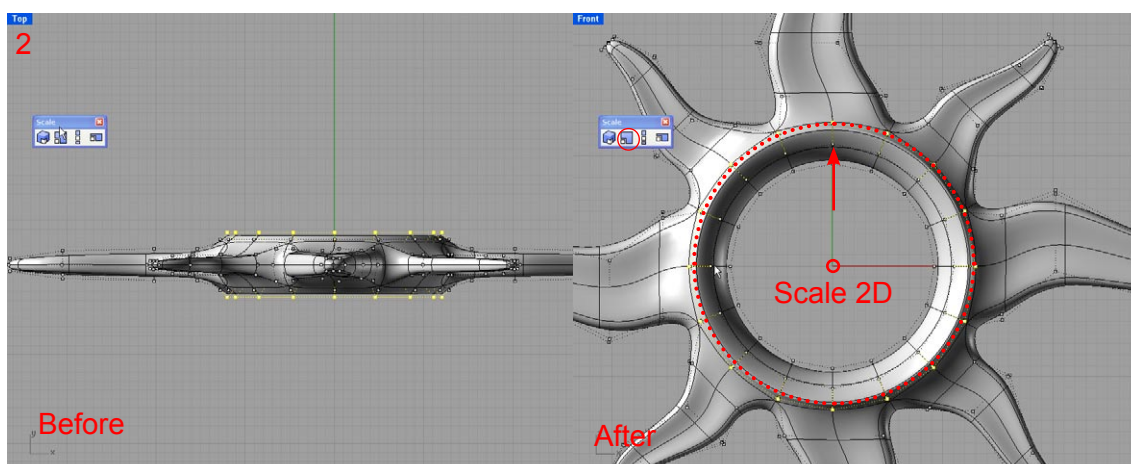

2-Select the control points shown and using `scale2D`, scale them outwards to create a sharper edge between the sun body and the sun rays.



11 T-Spline adjustments

Adding control points

We need to add some more control points using **tsInsertPoint** for the next step. Adding a control point near a star point (shown) will yield a small explosion of new control points to keep the surface unchanged; this influx of control points is desired in this case.

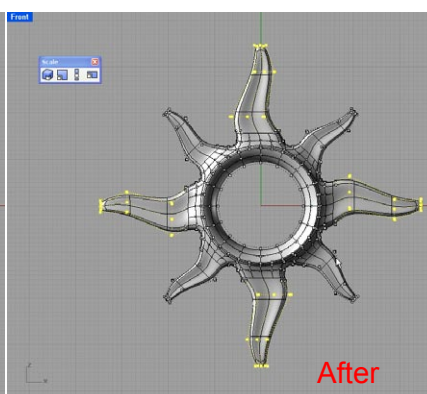
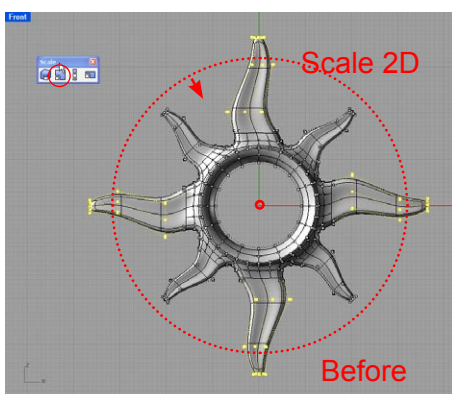
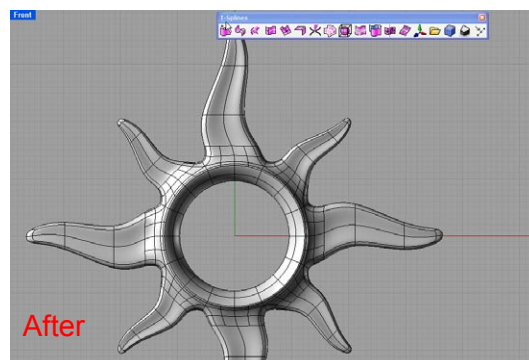
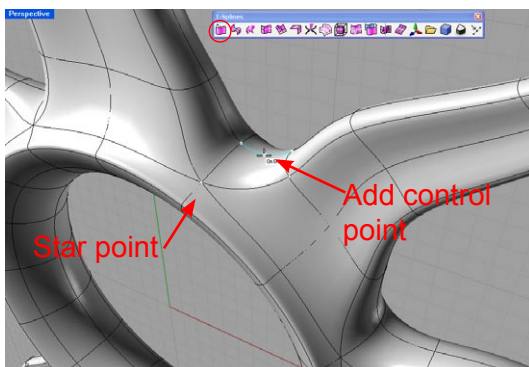

One more tweak before the next step: we'll adjust the sun rays proportions. Just select the last 3 rows of the big rays and **scale2D** through the center.

12 T-Spline adjustments

Creating a crease

Until now we have created a perfectly smooth T-Spline surface, but the design intention is to have a sharp edge on the inner part of the rays. Use **tsCrease** and select the first segments of each ray (both sides). The crease influence will extend across two isoparms.

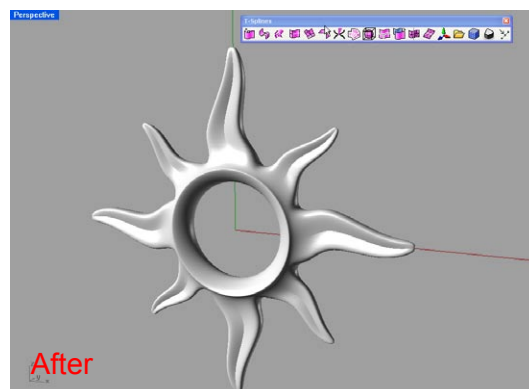
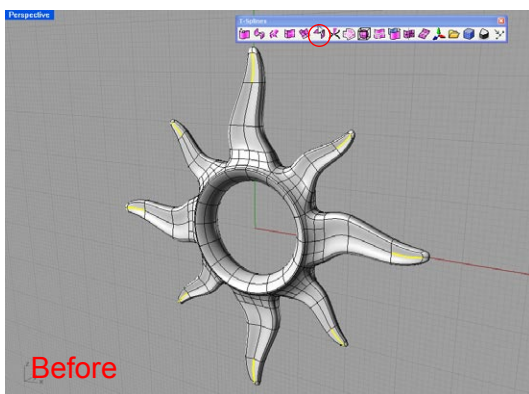



13 T-Splines modification

Creating the body details

Basically, what we are going to do on this step is generating some strips that will decorate the body.

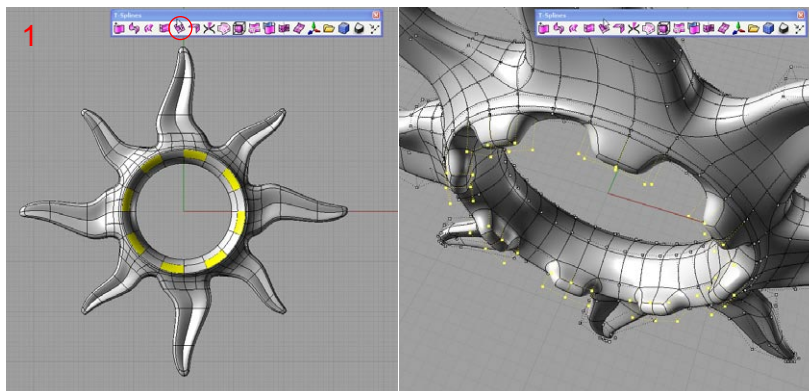

1-**tsExtrude** these front faces as shown.

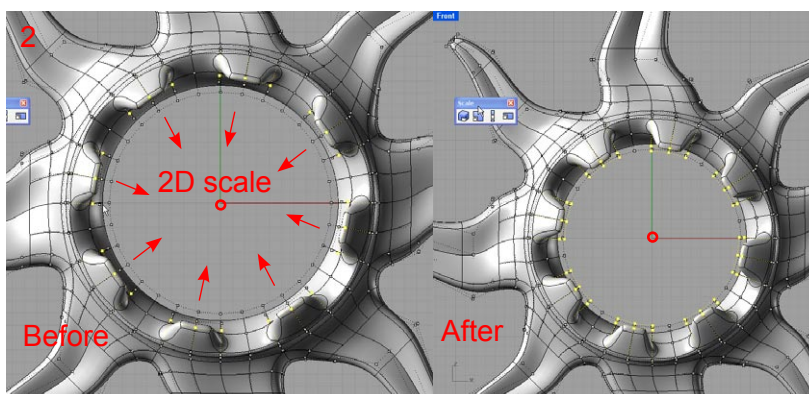

2-Once they are extruded, we need to change the angle of the control points on these faces. A good way to do this on all faces at once is to **scale2D** on the selected points shown.

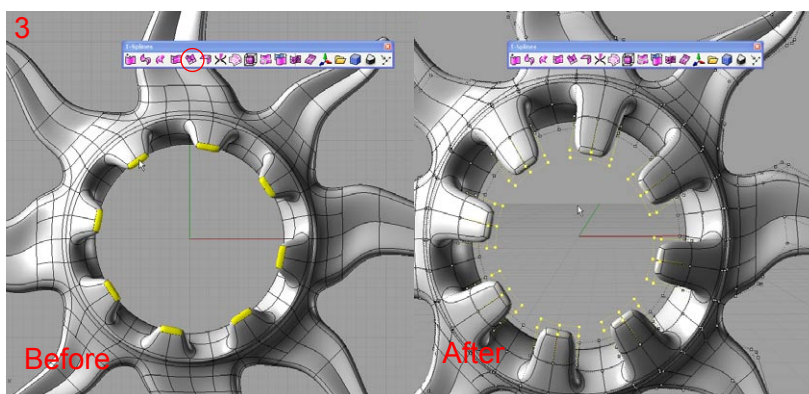

3-Now that we corrected the faces, it's time for another **tsExtrude**.

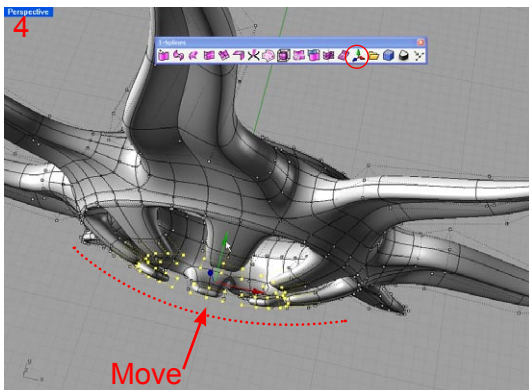

4-Keep the extruded points selected and use the **tsManip** to move +Y to get a convex body.

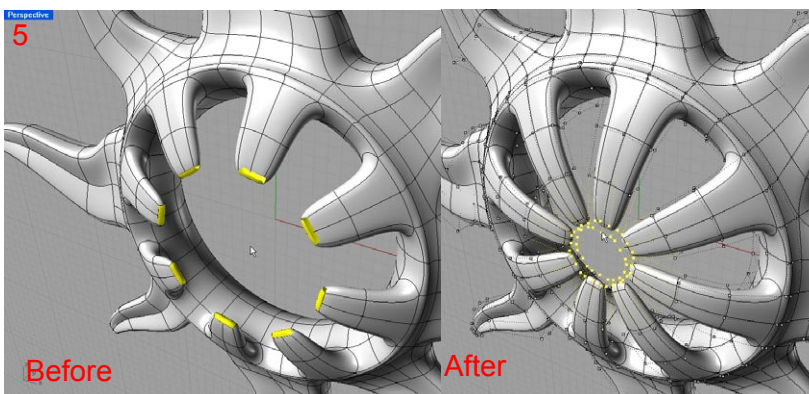

5-Now it is time for one last **tsExtrude**.

6-We need to **scale2D** these control points that were extruded last, this will give us smaller and closer tips. The center of the scale should be on the center of the earring in order to modify it symmetrically.

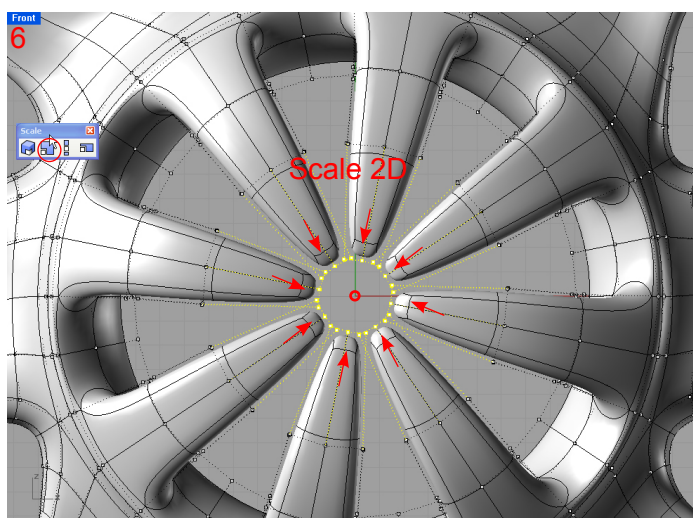



7-Now, we want the strips to be deformed in a spiral. To make the deformation more accurate, we first need to add more control points. To do this, just use **tsInsertPoint** near the star point shown. This will generate the needed geometry for the deformation.

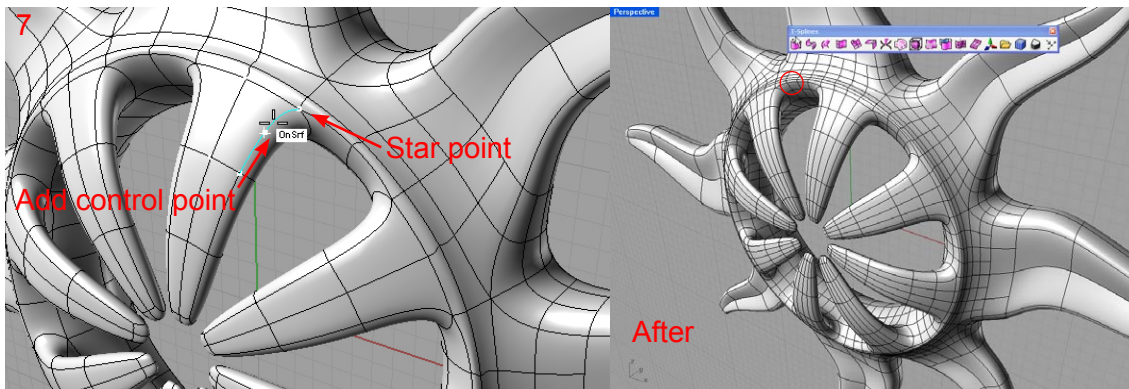

8-To make the spiral deformation we will use **Maelstrom**, one of the UDT tools. First, select all the control points that comprise the sun body strips. Be careful to not select other points. Second, use the **maelstrom** tool, where the center is the middle of the earring and the first and second radius are just those necessary for rotating the control points.

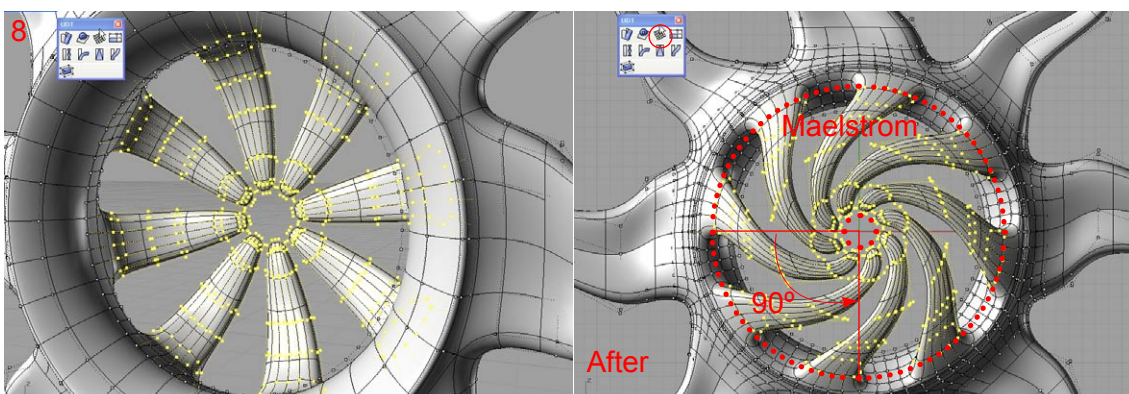

The T-Spline surface is done! Now we only need to add the remaining details.

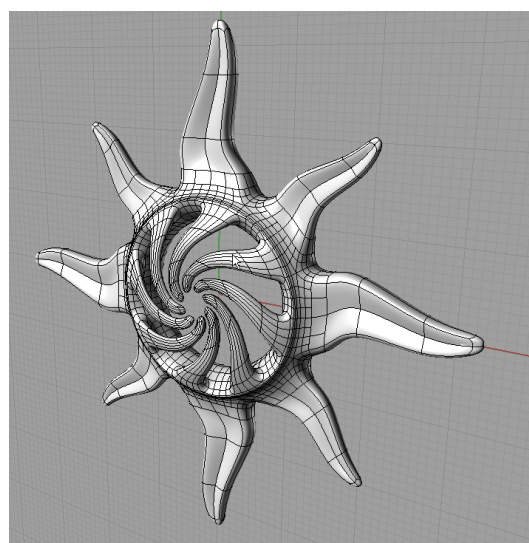



14 Other parts

Creating the center part

For the center piece we will just create the profile of a shape and then use **Revolve** to generate the geometry. You can use **ExtractIsoCurve** on the T-Spline surface to extract the curves that will be used for the center piece profile to get a perfect match between the parts.

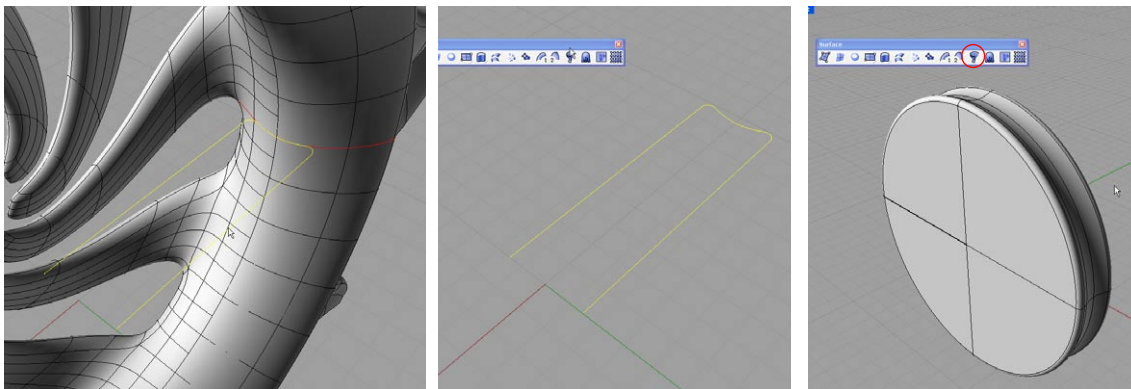

Creating the hook

This is simple, draw the curve and use **Pipe** to generate the piece.

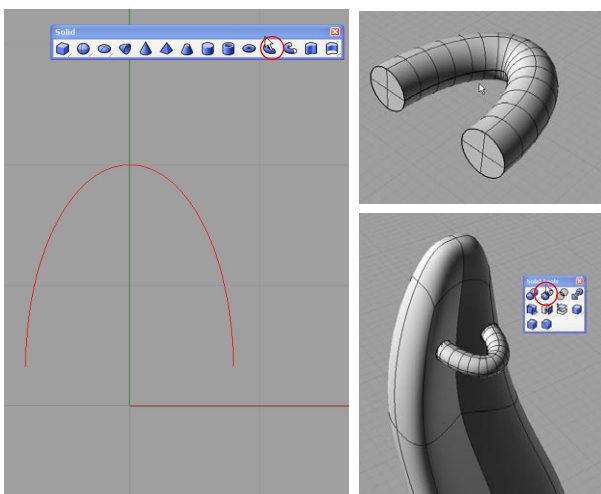
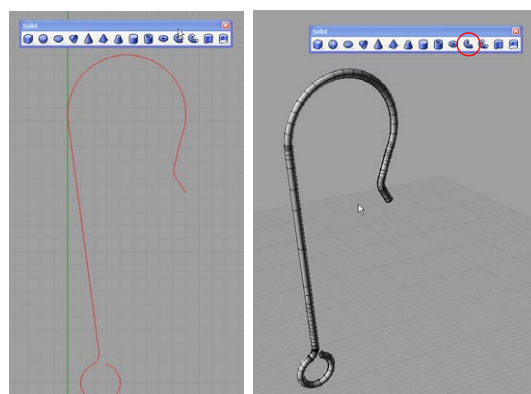

Union part

Draw the curve and use **Pipe** to generate the piece. Then just use **BooleanDifference** (Delete input=No) with the T-Splines surface.

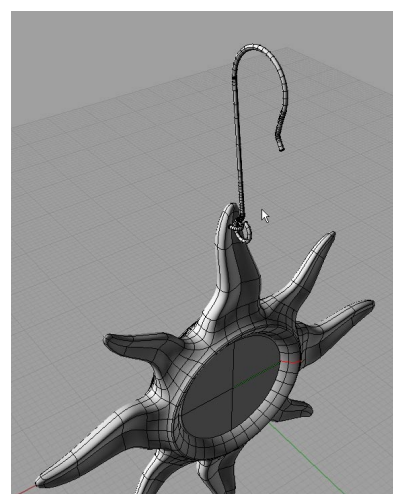

Move the parts to fit each other.

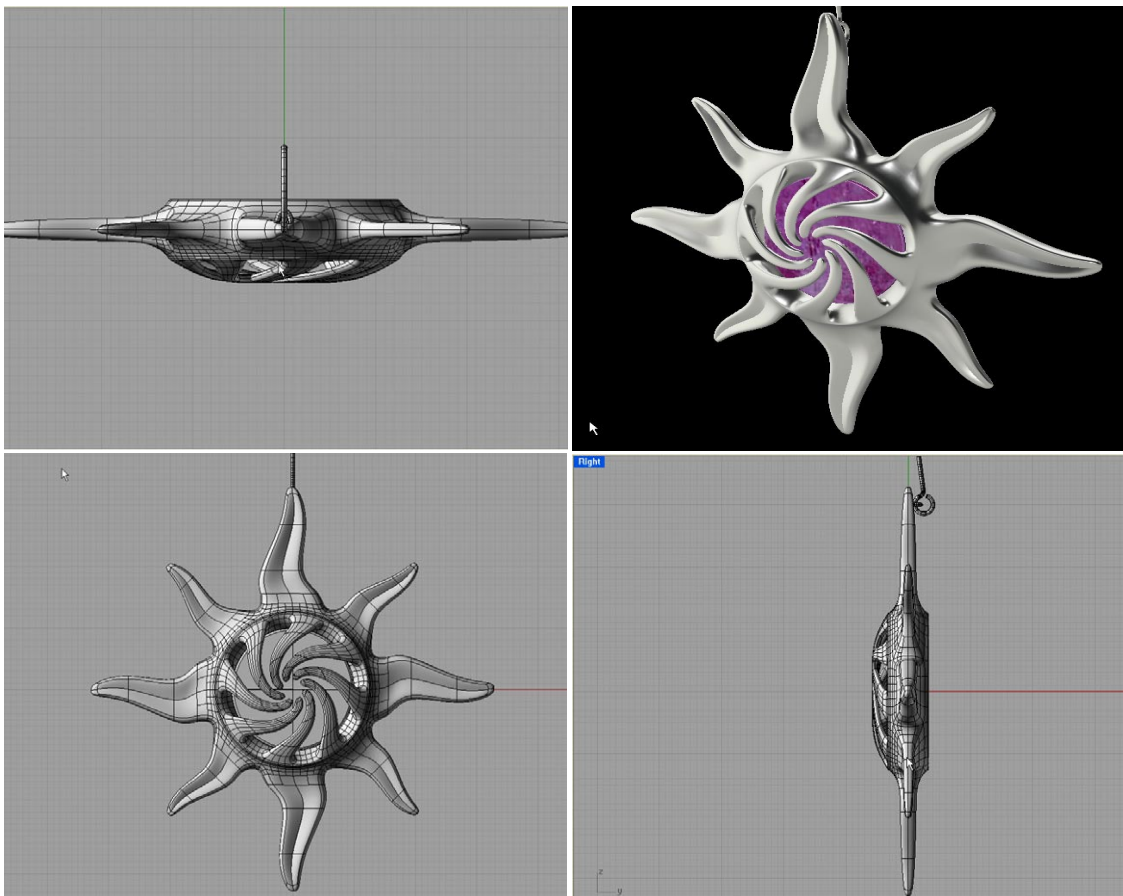

The result is a perfectly smooth, highly detailed 3D model of an earring ready to be manufactured.

Good luck in your modeling!
Write to my e-mail below with any questions.

Juan Santocono,
Industrial Design
jsantocono@fibertel.com.ar

A free trial of T-Splines for Rhino may be downloaded at www.tsplines.com