

# DESIGNING WITH PRECAST CONCRETE

## STRUCTURAL SOLUTIONS



TECHNICAL GUIDE



*Precast Concrete...  
Sustainable Structures for Tomorrow!*

Canadian Precast/Prestressed Concrete Institute





Precast Concrete...  
Sustainable Structures for Tomorrow!

## Canadian Precast/Prestressed Concrete Institute

196 Bronson Avenue, Suite 100, Ottawa, Ontario K1R 6H4

Telephone (613) 232-2619 Fax: (613) 232-5139

Toll Free: 1-877-YES-CPCI (1-877-937-2724)

E-mail: [info@cpci.ca](mailto:info@cpci.ca)

[www.cpci.ca](http://www.cpci.ca)

**President:** Robert Burak

**Managing Director Sustainability and Business Development:** Brian Hall

**Marketing Manager:** Joël Rochefort

DISCLAIMER: Substantial effort has been made to ensure that all data and information in this publication is accurate. CPCI cannot accept responsibility of any errors or oversights in the use of material or in the preparation of engineering plans. The designer must recognize that no design guide can substitute for experienced engineering judgment. This publication is intended for use by professional personnel competent to evaluate the significance and limitations of its contents and able to accept responsibility for the application of the material it contains. Users are encouraged to offer comments to CPCI on the content and suggestions for improvement. Questions concerning the source and derivation of any material in the design guide should be directed to CPCI.



# Table of Contents

Total Precast Concrete Structures .....	5
Long and Short Span Parking Garages .....	11
Residential Buildings .....	19
Educational Buildings .....	21
Industrial Buildings .....	23
Commercial Buildings .....	25
Stadiums and Arenas .....	35
CPCI Members .....	41
CPCI Resources .....	42
CPCI Certification .....	43

## List of Detail Drawings

### PARKING GARAGE DETAIL DRAWINGS

Drawing No.		
22	Pre-Topped Double Tees and Inverted Tee Beam Connection for Parking Structures .....	14
23	Pre-Topped Double Tee and L Beams At Expansion Joint .....	14
24	Pre-Topped Double Tee Supported By Wall Corbel .....	14
25	Pre-Topped Double Tee with Cast-In Wash at Wall .....	15
26	Double Tees Supported on Interior Walls .....	15
27	Double Tees at Top of Wall .....	15
28	Pre-Topped Double Tee Supported on Spandrel .....	16
29	Double Tee with Cast-in-Place (C.I.P.) Wash Supported by Spandrel .....	16
30	Non-Bearing Spandrel at Double Tee Connection with C.I.P. Wash .....	16
31	Non-Bearing Spandrel at Pre-Topped Double Tee Connection .....	17
32	Inverted Tee Beams to Column .....	17
33	Inverted Tee Beams at Wall Connection .....	17
34	Double Tee to Double Tee Flange Connection .....	18
35	Spandrel at Exterior Flat Column Connection .....	18

### RESIDENTIAL/EDUCATIONAL/INDUSTRIAL/COMMERCIAL DETAIL DRAWINGS

Drawing No.		
1	Section-Precast Column Base to Foundation .....	28
2	Section-Precast Wall Base .....	28
3	Precast wall to Exterior Foundation .....	28
4	Beam on Continuous Column .....	29
5	Cantilever or Continuous Beam / Column Connection .....	29
6	Continuous/Cantilever Beam to Column Connection .....	29
7	Wall to Floor Connection at Interior Variable Levels .....	30
8	Exterior Wall To Floor w/ Ledge .....	30
9	Interior Wall to Floor Connection .....	30

# List of Detail Drawings cont'd

## RESIDENTIAL/EDUCATIONAL/INDUSTRIAL/COMMERCIAL DETAIL DRAWINGS continued

Drawing No.		
10	Interior Wall to Floor Connection 2	31
11	Beam/Wall/Floor	31
12	Beam/Slab/Column/Wall Assembly	31
13	Interior Steel Lintel	32
14	Balcony with Exterior Wall	32
15	Hollowcore Slab to Lintel Connection 2	32
16	Wall/Wall Connection	33
17	Wall/Wall Connection—Exterior Corner detail	33
18	Wall to Wall Connection	33
19	Wall to Wall Connection—Interior Corner Detail	34
20	Exterior wall w/ Corbel to Slab Connection	34
21	Exterior Wall to Non-Bearing Slab Connection	34

## STADIUM DETAIL DRAWINGS

Drawing No.		
36	Raker Beam to Column	38
37	Stadia to Vomitory Wall Connection	38
38	Typical Stadia Seating Connection	38
39	Stadia to Floor Connection	39
40	Lower Seating to Cast in Place Wall	39
41	Stadia Seating to Raker Beam	39
42	Raker Beam to Column	40
43	Stair to Vomitory Wall	40



# Total Precast Concrete Structures

Total precast concrete building systems are a popular choice for many construction projects. Architectural and structural precast prestressed concrete components can be combined to create the entire building. This design approach can take several forms, including precast columns and beams with panelized cladding or load bearing precast walls and double tee or hollowcore flooring. The advantages benefit every member of the construction team — especially the owner, whose goals are always paramount.

**ARCHITECT:** In addition to helping to meet all of the building owner's goals, total precast concrete systems provide advantages to architects, such as a wide choice of colours, textures and finishes, and design solutions that can make the design process smoother.

**ENGINEER:** Experienced structural engineers easily adapt to design with total precast concrete systems, and they also benefit from available industry design tools and resources that ensure designs meet building code requirements and take advantage of the material's ease of use and efficiency. Engineering designs can also accommodate the requirements for seismic design and blast resistant structures.

**CONTRACTOR:** General contractors find the use of precast concrete components make their job easier at the site, ensuring a smooth process for the owner and designer in both the short and long terms. There are fewer trades to coordinate with precast construction.

## Fast Construction

Developers who use total precast systems say precast can significantly shorten the project timetable when compared with steel and even more when compared with cast-in-place concrete construction. These savings are critical in bringing a new building into a competitive marketplace or in meeting a tenant's need for occupancy on a specific date. A total precast system's speed helps keep projects on track.

## Scheduling Advantages:

- One-stop shopping sources much of a building's structure and shell within one efficient, precast contract.
- Plant fabrication of precast elements during permitting and/or site preparation and foundation construction saves time resulting in fast efficient construction regardless of weather conditions.
- Designing precast systems is easier thanks to assistance from CPCI member's engineering departments.
- Precast components can be erected in winter conditions, maintaining tight schedules. Speedy erection allows the contractor to enclose the building quickly, giving interior trades faster access.

## Fire Resistance:

- Precast components are naturally fire protected because they will not burn. Precast's inherent fire resistance eliminates the messy, time-consuming, and costly fireproofing required for a steel structure and subsequent repairs caused by other trades.
- In addition, insurance costs are less for precast structures during the construction phase.



## Aesthetic Variety

Precast concrete panels offer a wide range of styles. Panels can be produced in a variety of colours, textures and finishes providing an almost endless range of aesthetic options. Precast panels can replicate granite, brick or stone, achieving a bold image at a fraction of the cost. In addition to the myriad of architectural finish options, structural precast can also be aesthetically pleasing. Hollowcore slabs are normally left exposed. There is no need to add additional cost to the project for drywall or suspended ceiling at the underside of the deck slab. The joints can be caulked and the slabs can be painted and textured to display a bright, attractive ceiling. Using the cores as electrical raceways easily hides all of the electrical conduits giving an uninterrupted clean surface. Double Tees are also left exposed in parking garages or long span applications to display the very smooth and attractive concrete finish that is possible in a precast plant.

## High Quality

CPCI members supply precast concrete components certified to the CPCI Certification Program for Structural, Architectural and Specialty Precast Concrete Products and Systems. Certification is in accordance with the more stringent requirements of either CSA A23.4 *Precast Concrete – Materials and Construction* or the Precast Concrete Institute (PCI) Manuals MNL 116 and 117 (USA). Tight quality control ensures that components are produced with uniform consistency. More information on the certification requirements and a list of CPCI certified plants can be found at [www.precastcertification.ca](http://www.precastcertification.ca).



## Low Maintenance

Precast structures require less maintenance than buildings built using other materials. High quality concrete requires little to no maintenance, except for cleaning, and incorporating the architecture into the structure using large panel sizes minimizes the number of joints to maintain.

## Effective Pricing

Costs can be more accurately estimated earlier in the process with precast construction. Changes during design development can be quickly reassessed by CPCI member's engineering departments to update estimates. The contractor, owner and design team are assured that project budgets are accurate and achievable.

## Safety

Precast construction keeps the site cleaner and eliminates trades from the construction zone, improving logistics and enhancing worker safety. Site storage is usually not required — precast components are lifted by crane directly from the truck into position in a building. A clean site is particularly vital on building additions and new construction in dense urban areas, to ensure adjacent businesses maintain normal activities.

## Interior Design Flexibility

Long-span precast concrete systems help building owners adapt to changing client needs in future years. Hollowcore slabs and double tees can span up to 16 m (50 ft) to match typical composite-steel framing bay sizes and minimize the need for interior columns required with cast-in-place systems. Precast can span as far as 21 m (70 ft) to provide flexibility for challenging interior requirements providing high load capacity at little added cost.



## Early Input

CPCI members can provide early and precise design assistance to help select the most efficient sizes and shapes for components, and optimization for casting, transporting and erecting precast components. Repetition reduces costs and reduces overall schedules while retaining design flexibility. These cost efficiencies can free up more of the budget for other critical design areas.

## Strong Finish- Approval Process

Precasters can provide finish samples, range samples and large-scale mockups, ensuring that design concepts translate into reality. Designers can inspect window interfaces, joint connections and other critical elements to ensure they are visually acceptable and will properly interface between trades. Visits to manufacturing facilities to discuss technical and aesthetic concerns provide the necessary control without constant site supervision.

## Sustainable Design

Precast concrete offers a number of benefits that make it environmentally friendly and also meet the goals of programs such as Leadership in Energy & Environmental Design (LEED™ Canada) and Architecture Canada's 2030 net zero challenge. Precast concrete buildings can be designed for disassembly and adaptability, and are easily deconstructed for reuse at the end of a building's life.

Precast's energy efficiency, reduction in materials, recyclability, reusability and ability for repurposing, along with minimal waste in the precast plant and on the jobsite, are keys to meeting environmental standards. In addition, with building codes requiring higher energy efficiency, integrated solutions using hollowcore slabs for heating and cooling are a growing trend in building design that reduces energy consumption. With precast's ability to aid in meeting LEED™ standards, other benefits such as thermal mass become more apparent to designers. The use of fly ash, slag and other waste materials aid in reducing a building's environmental footprint. Precast's high durability produces buildings with a total service life that outpaces other systems or materials.

Precast concrete demonstrates comparable environmental impact performance over alternative structures and building envelope solutions demonstrated by the ISO compliant research study, *CPCI Life Cycle Assessment of Precast Concrete Commercial Buildings (2012)*. Visit [www.sustainableprecast.ca](http://www.sustainableprecast.ca)



Two related Canadian standards offer important resources for design professionals when designing with precast. CSA Z782-06 *Guideline for Design for Disassembly and Adaptability in Buildings* provides a framework for reducing building construction waste at the design phase, through specific principles. CSA Standard Z783, *Deconstruction of Buildings and their Related Parts* provides minimum requirements for processes and procedures connected with the deconstruction of buildings. It is intended for use by contractors, consultants, designers, building owners, regulators, and material chain organizations undertaking deconstruction of a building that is at the end of its life or when it is undergoing renovations or alterations.

## Construction

Contractors can minimize the added “cushion” created in schedules to accommodate bad weather conditions, since precast components can be produced and erected all year round.

## Efficient Erection

Designs meet specifications and expectations because precast concrete pieces are fabricated and inspected in precast plants under controlled conditions using high-quality materials. Field adjustments are reduced, creating a smooth erection process.

## All- In- One Components

Total precast concrete systems allow the architectural wall panels to also serve structural functions. Combining architecture and structure can provide efficiencies in a building’s support systems. Insulated spandrel panels can support floor systems and windows while providing architectural exterior finishes. Precast elevator and stair cores can support floor systems while providing secure, fire rated enclosures.

## Comprehensive Design and Coordination

A total precast concrete system ensures one-stop shopping for the entire core/shell design. CPCI members can design and supply the entire system using 3-D building information systems (BIM), generating a well coordinated set of drawings to allow design, fabrication, construction and erection to proceed more efficiently. This eliminates the added effort needed to coordinate various trades when using mixed systems controlled by different suppliers.

## Shape and Design

Precast components are custom manufactured to match design requirements. Unusual shapes, sizes and specific technical requirements are expertly fabricated in CPCI member precast plants. Repetition of shapes and sizes greatly enhances the economical use of precast components.







## Precast Structural Components

Precast concrete beams, columns and stairs are the ideal solution for owners and builders who want to achieve wide-open spans, fire resistance, energy savings and attractive design with one structural system. Precast beams may be either continuous with single storey columns or single span beams with multi-storey columns. The use of standardized forms accelerates the manufacturing process. The quality of smooth formed finishes produced in a precast plant saves money by allowing designers to expose the structure in a finished building.

**Design Note:** Total precast structures and structures that incorporate precast as part of the structural system must be adequately tied together, to resist lateral loads as a system. Clause 16.5 (Structural Integrity) in CSA A23.3 *Design of Concrete Structures* provides the designer with the code requirements necessary to provide structural integrity in buildings where precast concrete elements make up a portion or all of the structural system.

## PC-3D and BIM

Total precast projects can now be modeled using PC-3D and building information modelling (BIM). These software solutions allow manufacturers, designers, and consultants to readily develop and visualize the many facets of precast construction. Construction methods, layouts, details, reinforcing and erection procedures can all be readily visualized. Drawings

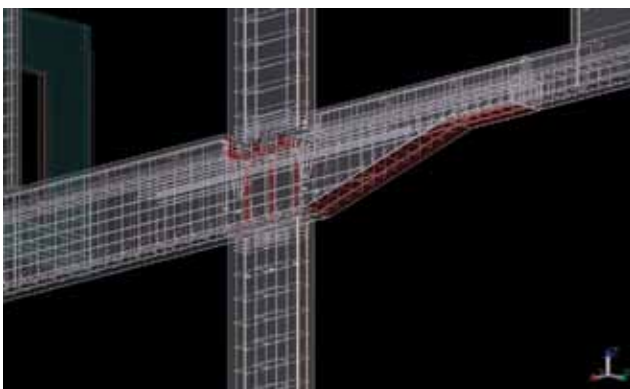
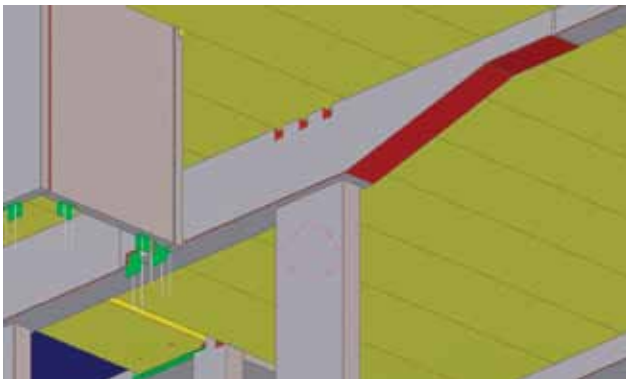

required to produce individual precast pieces and erection layout drawings are all generated directly from the software.

Projects can be “pre-built” within the virtual world of BIM software. Geometry, details, and connections can be developed. Design issues can be easily identified and resolved prior to manufacture and erection. Potential project complications can be examined within the model, and resolved prior to issuing drawings for construction. PC-3D and BIM modeling inherently removes the possibility of misaligned connections or geometry conflicts, and provides a database of information useful for estimating, production, and erection.



# Long and Short Span Parking Garages

Parking structures often represent the first and last impression a visitor has when visiting a facility. Excellent parking structures are designed specifically for the types of visitors a structure will serve. Unless a parking structure is safe, secure and easy to use, parkers will find other options. Creating the best parking structure to fit the site requires a careful balance of all elements and a logical plan from start to finish. The involvement of your local CPCI member from the beginning, while key design decisions are being made, can make a dramatic difference to the final result. Their expertise and input can minimize the time and cost required to complete a project. Precast parking garages offer fast construction, versatility of design, attractive exterior finishes, durability and economy making precast prestressed concrete a popular choice for commercial, municipal and institutional clients.

## Loads and Forces

Precast concrete parking structures allow for volume changes from creep, shrinkage and temperature differences. Components are cured before they are delivered to the site. The connections between members allow a structure to relieve pressures from ordinary expansion and contraction that otherwise could cause cracking in structural cast-in-place (CIP) elements. Lateral design loads due to wind, earthquake or earth can be resisted in a precast concrete structure by transferring loads through the floor diaphragm to shear walls and/or to column beam frames.

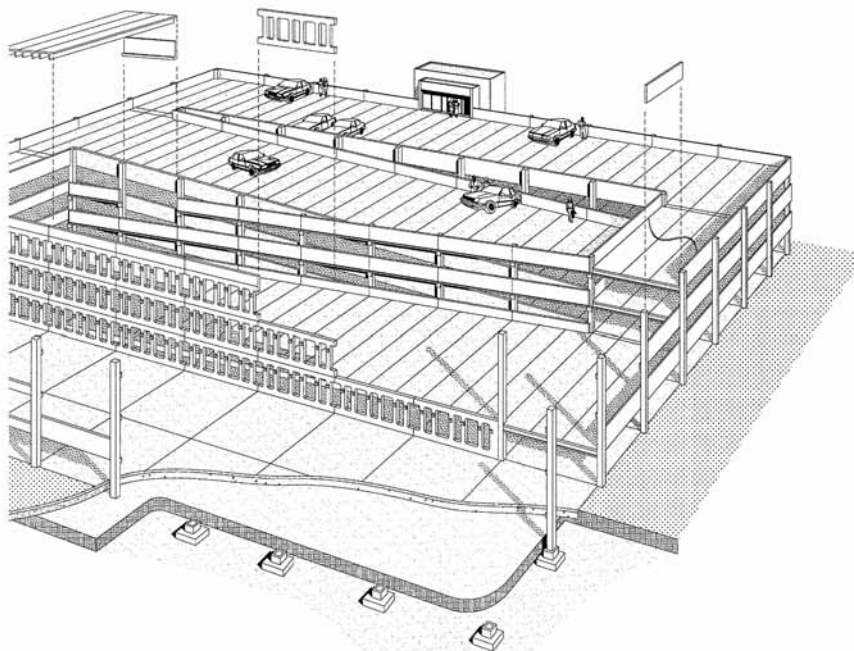

Care in locating shear walls and isolation (expansion) joints will enhance performance. Loading exterior walls with framing beams or floor members can minimize connections between shear walls to resist uplift forces. Connections can be designed to prevent beam rotation and absorb bumper loads without undue restraint against volume changes.

## Bay Sizes

For maximum economy, bay sizes should be as large as practical and modular with the standard precast concrete floor elements selected. For long span parking, the bay size selected need not be a multiple of the width of the parking stall. Clear spans of 18 m (60 ft) with fewer columns create an open concept for added security.



## Drainage

Sloping of floors to achieve good drainage is essential to quickly remove rain and salt laden water from the structure. The drainage pattern selected should repeat for all floors wherever possible to allow for repetition in manufacturing the precast elements. Locate isolation (expansion) joints at high points to minimize possible leakage. Slope the floors away from columns, walls and spandrels to promote proper drainage.



## Durability

High strength precast concrete components are cast under controlled conditions in the precast plant. Prestressed slabs and beams are virtually crack-free and highly resistant to attack by chloride ions. Where cast-in-place (CIP) composite topping is used over precast floor members, wire mesh reinforcement should be incorporated in the topping. A properly cured high strength concrete topping having a water/cement ratio of 0.40 or less, 6% entrained air, will produce the best results (see CSA S413 *Parking Structures*). A series of crack control joints should be tooled into the topping above all joints in the precast members below. A V-shaped trowel will produce a 25 mm deep by 12 mm wide joint. Later these joints are prepared by grinding with a V-shaped abrasive wheel and filled with a polyurethane sealant.

Pre-topped double tees are a recommended alternative to field-placed concrete toppings. This system provides excellent 35 to 55 MPa plant produced wearing surfaces with a broom finish to provide improved driving traction. Standard details are used for adjacent camber differential, joint treatments, erection stability and drainage with this system. Connections and exposed hardware can use hot dipped galvanizing or stainless steel for the double tee flange to flange and other connections. Where connections are subsequently welded, the welds should be minimal and located where they can be covered or easily maintained.

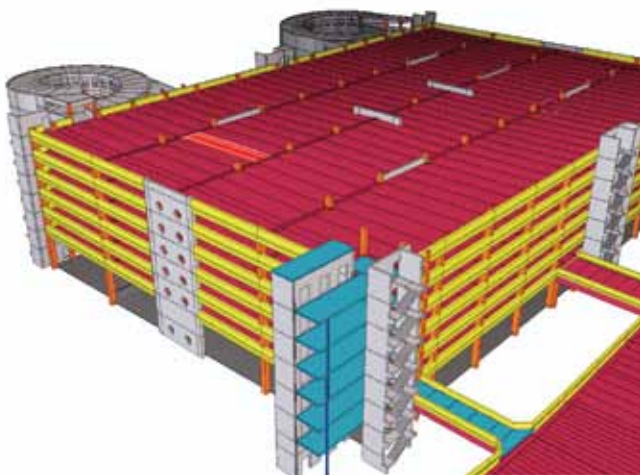

---

## PARKING GARAGE

---



---

## DETAIL DRAWINGS

---

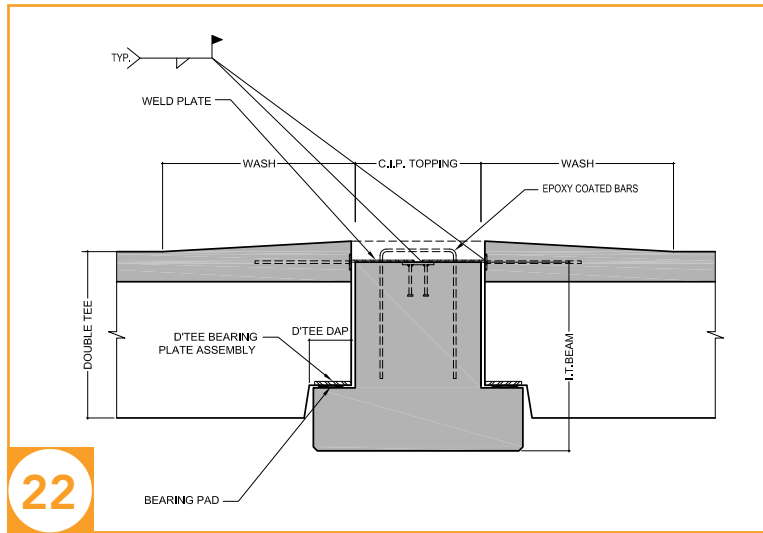

Pre-Topped Double Tees and Inverted Tee Beam Connection for Parking Structures

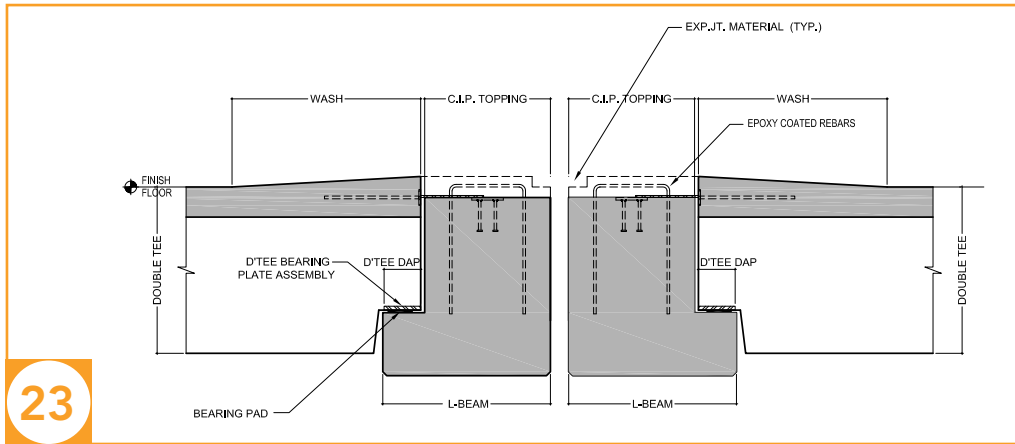

Pre-Topped Double Tee and L Beams At Expansion Joint

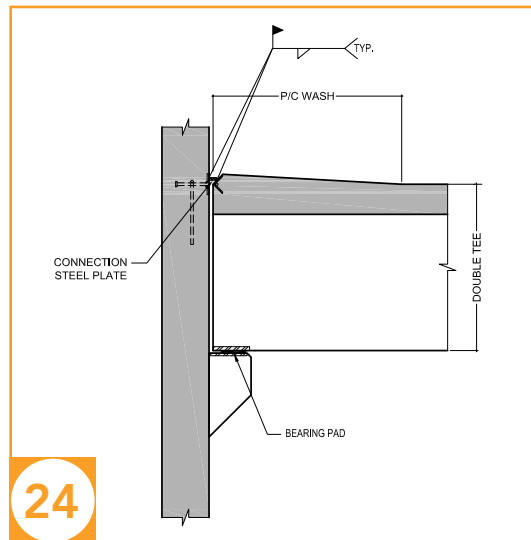

Pre-Topped Double Tee Supported By Wall Corbel

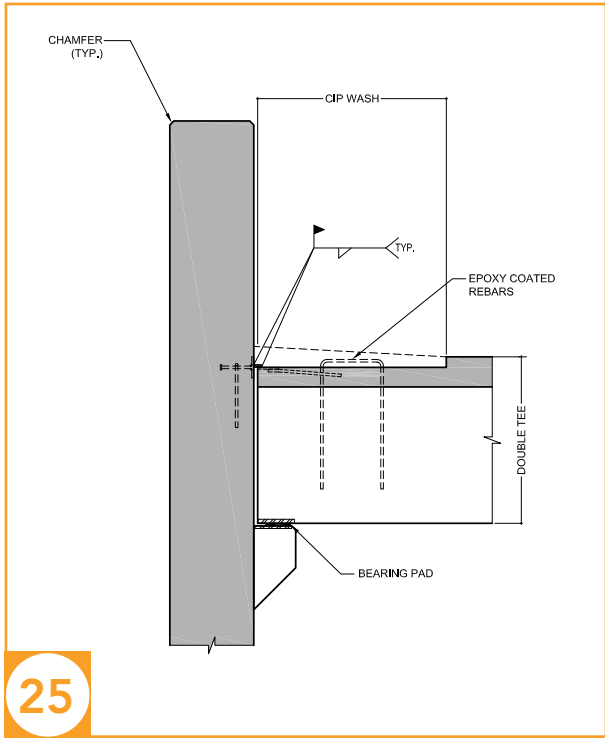

25

Pre-Topped Double Tee with Cast-In Wash at Wall

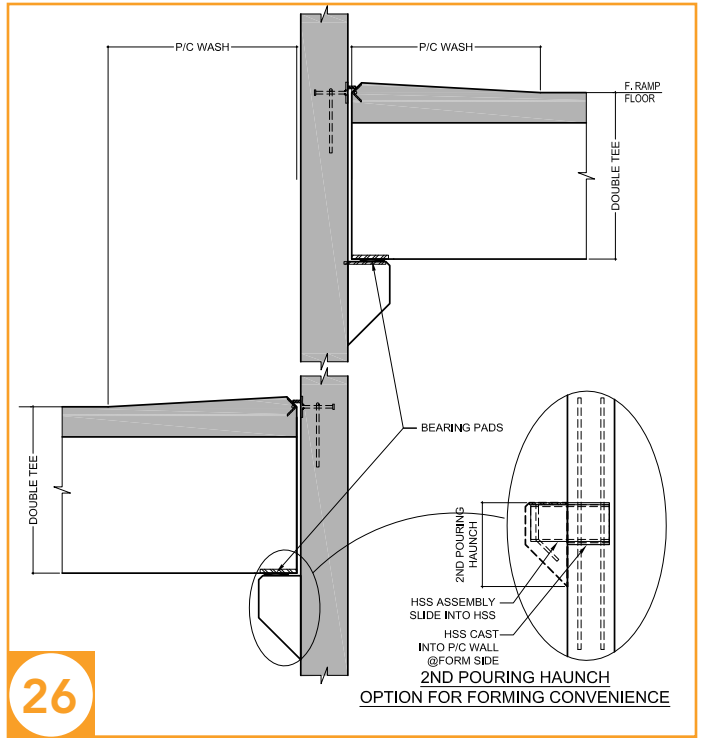

26

Double Tees Supported on Interior Walls

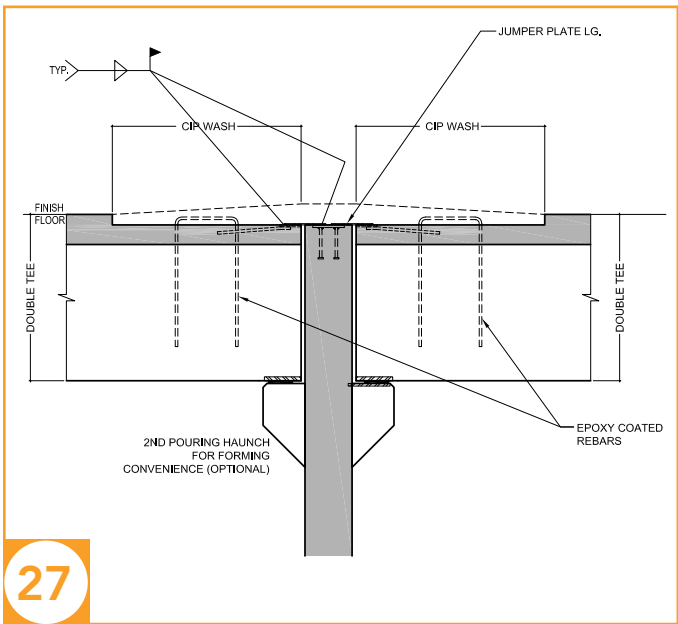

27

Double Tees at Top of Wall

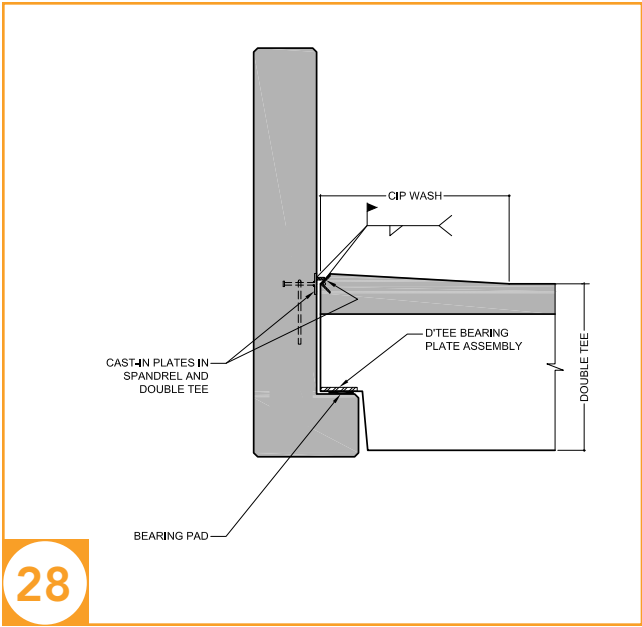

28

Pre-Topped Double Tee Supported on Spandrel

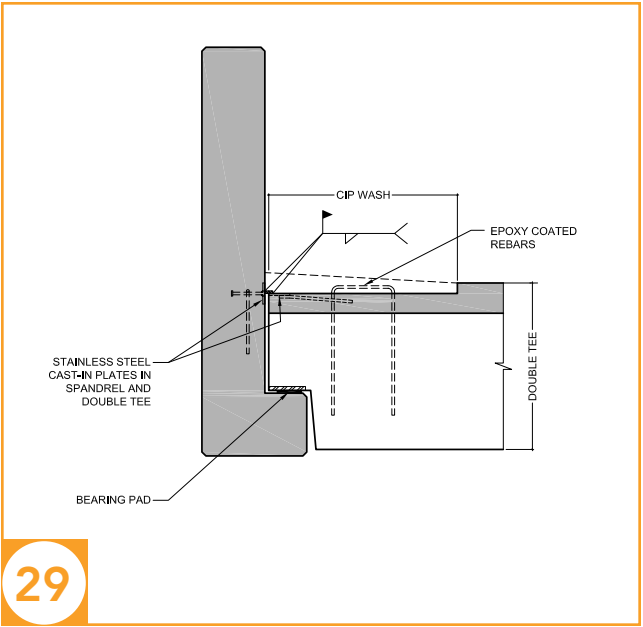

29

Double Tee with Cast-In-Place Wash Supported by Spandrel

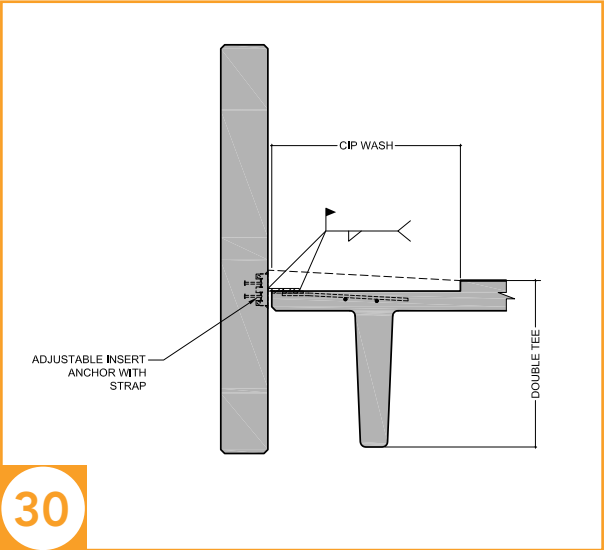

30

Non-Bearing Spandrel at Double Tee Connection with Cast-In-Place Wash



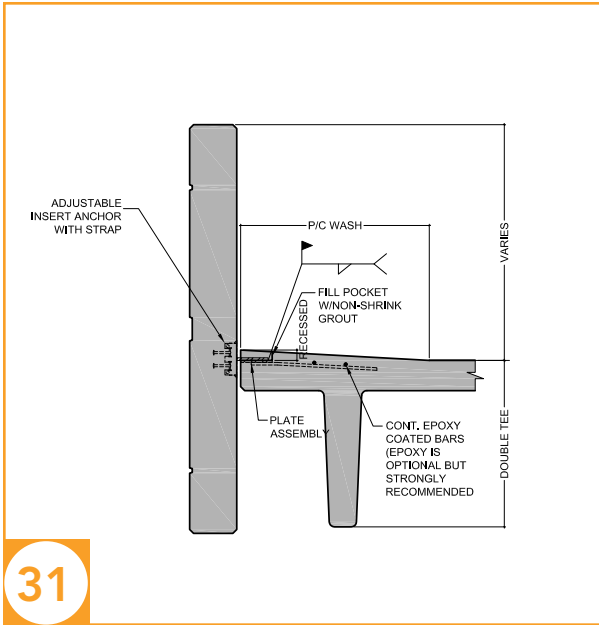

31

Non-Bearing Spandrel at Pre-Topped Double Tee Connection

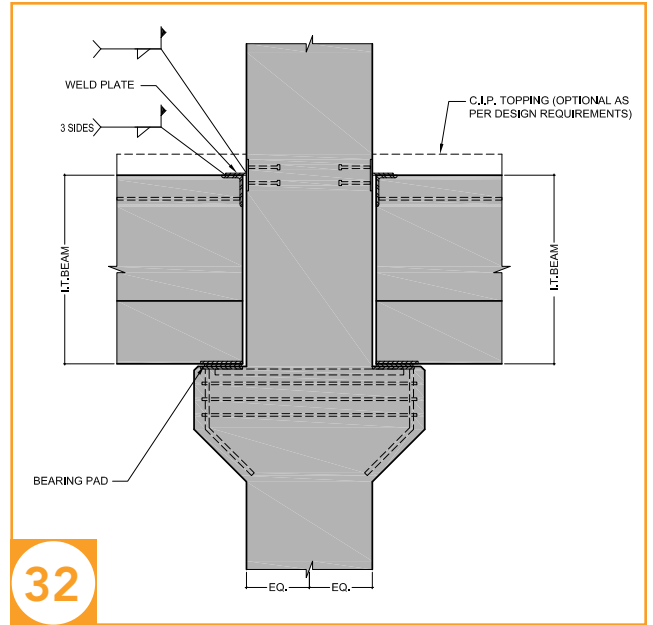

32

Inverted Tee Beams to Column

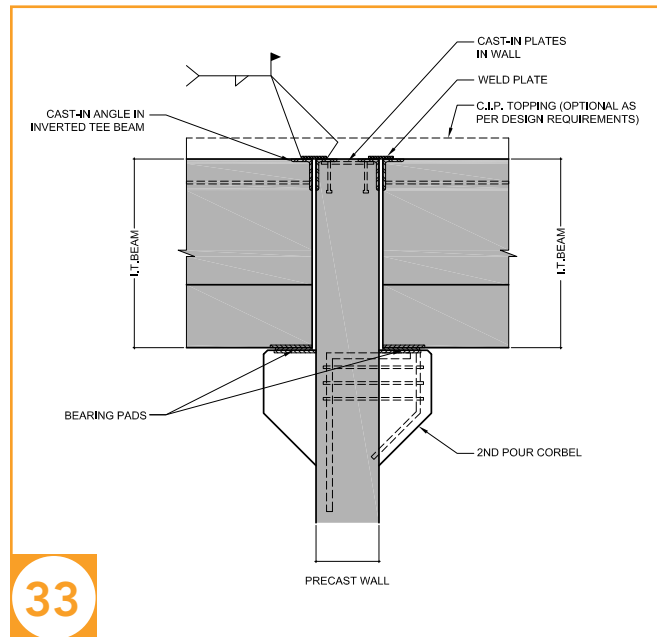

33

Inverted Tee Beams at Wall Connection

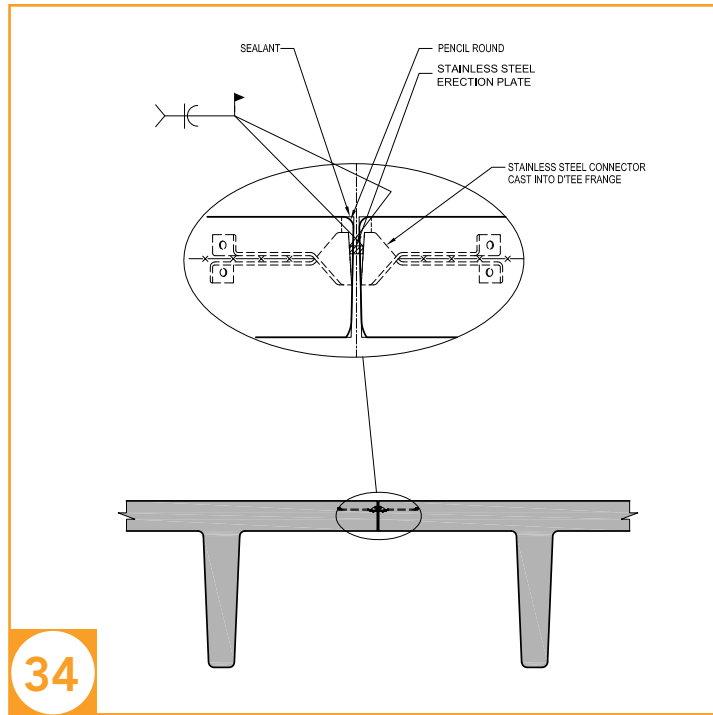

Double Tee to Double Tee Flange Connection

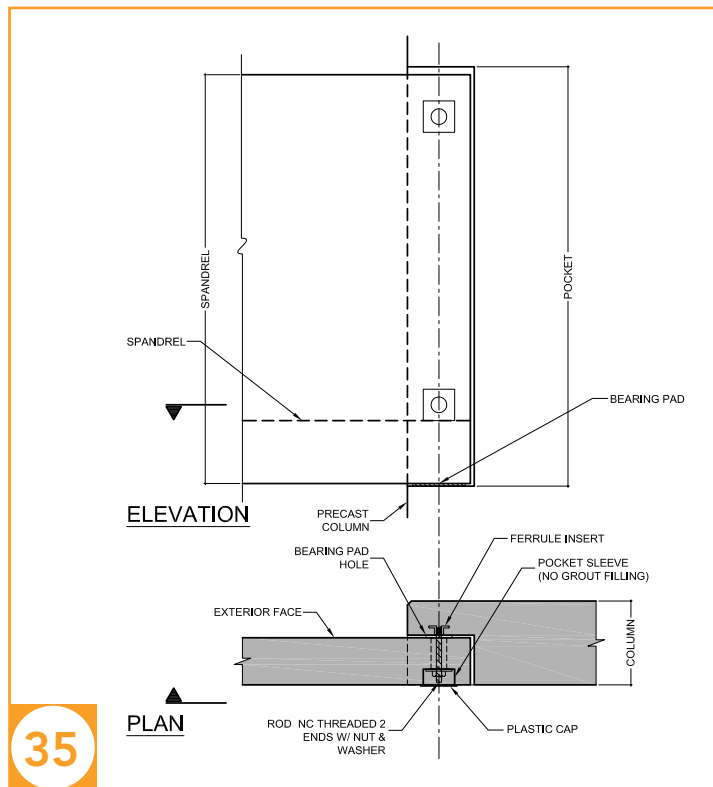

Spandrel at Exterior Flat Column Connection

# Residential Buildings



Precast and prestressed concrete enjoys broad acceptance in low-rise and mid-rise apartment buildings, hotels, motels, and nursing homes where the repetitive use of standard components manufactured in a factory can be fully utilized. The superior fire resistance and sound control features are specifically recognized by owners and developers.

## Floors and Roofs

Hollowcore slabs are popular for this type of construction. The most common floor and roof elements employed are 203 mm (8 in) deep untopped hollowcore units. These slabs can span up to 9 m or more without intermediate supports. Longer spans can be achieved by using 254 mm (10 in), 305 mm (12 in) or 355 mm (14 in) deep hollowcore units. For hotels, motels and apartments the hollowcore

slabs are oriented to span most commonly between load bearing elements. The underside of hollowcore slabs can be utilized as the finish ceiling for the floor below thus reducing costs. Balconies can be cast as separate units to provide a thermal break at the exterior walls.

## Speed of Construction

Precast components can be manufactured and erected by one trade more efficiently and quickly than any other building system. Speedy completion means buildings can be occupied and start generating revenue sooner. The use of precast walls speeds the erection process. Construction rates of one floor per week and better are often achieved. Integrally insulated architectural wall panels used for the exterior of a building can provide a durable, attractive, energy efficient envelope.



## Faster Occupancy

Owners and developers are discovering that for low-rise and mid-rise apartment buildings, hotels, motels, and nursing and long-term care facilities, precast hollowcore concrete floors combined with precast walls can be the true winner for getting projects finished fast, generating revenue sooner and maintaining quality, value and fire resistance.

## Comfort and Security

The solid, secure, high-quality appearance of solid precast construction encourages greater occupancy at higher rents, with better selling and resale values. Precast concrete offers some of the lowest sound transmission of any building material used for multi-unit housing. When ceilings and floors are made with precast floors and walls, complaints about noise become a thing of the past. Tenants like the sense of security of a building that is solidly built, fire resistant and free of decay. Occupants know their families are safe and their possessions are protected.

## Precast and Fire Safety

A major concern when building assisted living/retirement multi-family housing is fire safety of lives and property. An effective approach to this fire containment challenge utilizes "Balanced Design" that consists of three elements: containment, detection and suppression. Containment, the key ingredient in Balanced Design, requires fire resistant building materials with a two-hour or higher fire rating. A multi-unit structure built with precast floors and roofs, combined with precast dividing walls, can contain a fire to within the unit of origin, leaving the occupants safe and the surrounding areas virtually undamaged. Other systems such as wood frame construction do not offer the same benefits of precast concrete for Balanced Design and fire safety, without the addition of costly materials and fire suppressant strategies.

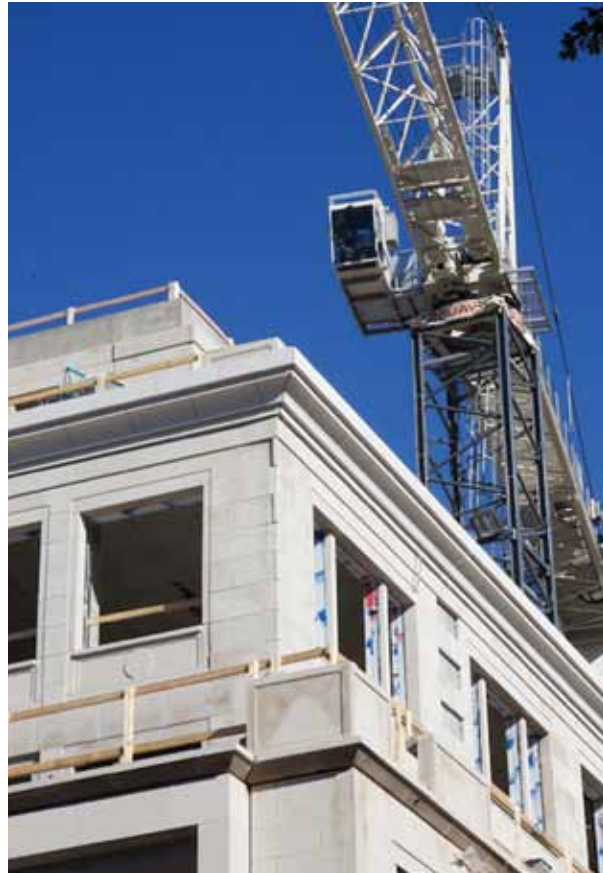

# Educational Buildings

Precast prestressed concrete has been the preferred material for school, college and university building structures, providing design flexibility and fast construction. The superior finishes achievable in a precast plant have enabled many designers to expose the structure in the finished building. Durable, good looking exterior finishes using architectural precast panels provide years of maintenance free use. In addition to classroom and office facilities, student residences, auditoriums, gymnasiums and school swimming pools have been constructed using long span precast concrete floor and roof members.

Educational buildings are being designed using architectural and structural precast, prestressed concrete components that include:

- Load-bearing and non load-bearing precast concrete wall panels
- Hollowcore and double tee floor/roof slabs
- Precast columns and beams

Unmatched advantages are realized when precast components are combined to form a total precast concrete school structure including:

- economy
- reduced construction time
- improved quality and durability

An educational building designed as a total precast system provides the best design solution.



## Fabrication & Erection Speed

Precast components can be fabricated in the precast plant while foundation work is in progress. Wall panels, double tees, and hollowcore slabs can be erected quickly, allowing interior trades to begin work earlier, cutting weeks and months from the schedule. The fast enclosure of a building constructed of precast concrete reduces a contractor's costs and risks from weather or delays during construction.

## Instant Brick

Brick-faced precast panels can be provided to ensure a high-quality, even-spaced appearance that is difficult to achieve even with site-laid-brickwork. Thin-brick and/or half brick can be cast in the face of precast panels at the precast plant to provide the exterior finish that many school districts desire. Plant installed inset bricks eliminate the long construction time needed for on-site hand-laid brick, thus removing several trades from the project site. Precasters can also use brick form-liners to create a brick pattern finish that is then stained to closely simulate a brick finish as another economical alternative.



## Optimized Floor Area

Integrally insulated precast wall panels offer an energy efficient, thin cross-section that helps to maximize interior floor space. Typical insulated precast panels are 200 mm (8 in) to 250 mm (10 in) thick. Masonry walls may be up to 400 mm (16 in) thick. This space saving throughout a school can increase interior space, speed construction and produce a more energy-efficient building.

## Long Spans

Precast hollowcore and double tee slabs offer tremendous design flexibility by providing long clear spans. Load-bearing precast wall panels can reach heights of 17 m (55 ft), while double tee floors and roofs can span up to 30 m (100 ft). This opens up the interiors of auditoriums, gymnasiums and pools while reducing material costs and interior columns.

## Durability

Precast concrete is highly durable, ensuring long life with minimal maintenance. Integrally insulated precast wall panels provide an attractive and durable interior finished surface, a particular advantage in gymnasiums and other areas that receive heavy-duty use.



## Low Maintenance

Maintenance is minimized during a school's lifetime thanks to precast's durability. Panels typically require recaulking of their joints every 15 to 20 years. Solid precast construction provides durable and long lasting interior concrete floors and walls that resist damage and alleviates concerns about mould formation.

## Fire Safety

Precast concrete is a non-combustible material that meets all fire-code provisions without requiring any additional spray coatings or protection. This resistance speeds construction, eliminates other trades from the site and provides an inherent passive level of protection. Precast components will not create lethal smoke and will maintain their structural integrity even when subjected to the most intense heat. Designing with a total precast system maximizes the time for detection, evacuation and suppression.

# Industrial Buildings

High strength precast concrete resists fire, moisture penetration and a variety of chemical substances. The clean, smooth surfaces obtainable in a precast concrete factory make this material ideal for food processing, computer component manufacturing and wet processing operations where cleanliness is a concern. The ability of precast prestressed concrete to span long distances; hollowcore 9 to 15 m (30 to 50 ft); double tees 20 to 30 m (65 to 100 ft); single tees 25 to 40 m (80 to 130 ft) and carry heavy loads with minimum span/depth ratios are particularly useful in the construction of warehouses and industrial buildings. Spans of 45 m (150 ft) or more can be obtained using custom solutions (prestressed bridge girder sections).

Precast floor and roof framing can be designed to accommodate a variety of mechanical systems and support heavy industrial uses such as hanging loads and bridge cranes. Precast insulated wall panels can be readily used as load bearing exterior walls or cladding. Roof and floor elements can bear directly on pockets or haunches provided on the inside faces of wall panels. Exterior walls can be formed using standard shapes efficiently prestressed in long line production facilities. Custom shapes can be produced in architectural molds with a variety of smooth, sandblasted or exposed aggregate exterior surface finishes. Precast components require little maintenance. Precast concrete resists abrasion, weathering and many harsh chemicals. Precast walls and ceilings can easily withstand high pressure wash downs and cleanings. Precast concrete floor and roof systems can be constructed without horizontal ledges, common to steel roof construction. This eliminates locations where dirt and bacteria can accumulate.





## Pulp & Paper Mill

Pulp mills require clean non-corrosive interior surfaces. Precast structures can often be designed to accommodate industrial equipment, cranes, monorails, mechanical systems and electrical systems. Often a modular grid of openings, sleeves or inserts is provided throughout the precast structure to allow for multiple options during construction and for flexibility to accommodate potential changes, modifications and additions to the mill's processes and equipment. Precast structures save owners money by avoiding high material and labour costs often associated with industrial buildings that are constructed in remote areas.

## Precast Panel Systems

Integrally insulated precast wall panels are ideal for industrial applications. Panels can be provided with insulation values to suit project requirements. Exterior and interior finishes can be smooth, coloured or textured. Panels can be easily reused and relocated to accommodate future building expansions (see CPCI publication, "Insulated Wall Precast Concrete Technical Guide" for more information).





# Commercial Buildings

The combination of high quality architectural load bearing exterior walls with standard factory produced structural precast floor and roof members can produce open, attractive, fire resistant, economical buildings. The quality finishes and improved construction schedules result in early occupancy, tenant satisfaction and reduced financing costs that makes precast concrete buildings very suitable for commercial office buildings. Significant time savings can be achieved by selecting a total precast concrete structure. The superstructure is prefabricated in the precast plant while the on-site foundations are being formed and placed. Potential delays are reduced with the complete building system being supplied under one contract without numerous trades being involved.



Long span double tee or hollowcore floors reduce interior framing and provide large column-free areas within the building, allowing flexibility and diversity with interior layouts. Architectural precast finishes can be throughout the interior of a building for columns, atrium framing, entrances and elevator shaft walls.

Interior or exterior shear wall systems and rigid beam/column frames have all been successfully used to resist lateral forces and provide building stability.



Erection of large precast concrete components can proceed even during adverse weather conditions to quickly enclose the structure. Load bearing architectural precast panels provide the finished exterior as the superstructure is erected. The prestressed floors provide an immediate working platform allowing the interior trades an early start on the mechanical, electrical and interior finishing work.

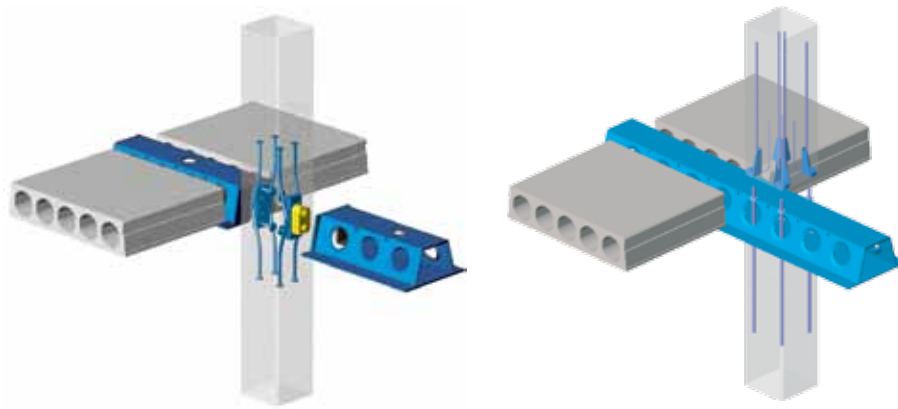

Precast Column and Composite Beam with Hollowcore (continuous beam and continuous column isometric views)

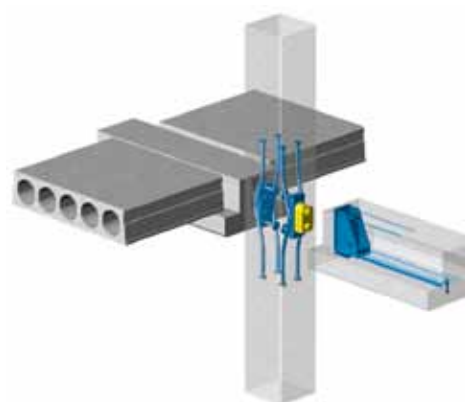

Precast Column and Inverted Tee Connection with Hollowcore— Isometric view

---

# RESIDENTIAL/EDUCATIONAL/INDUSTRIAL/COMMERCIAL

---



---

## DETAIL DRAWINGS

---

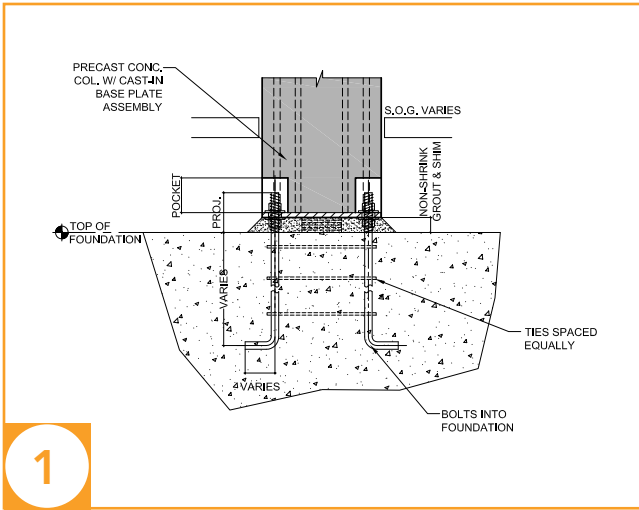

Section-Precast Column Base to Foundation

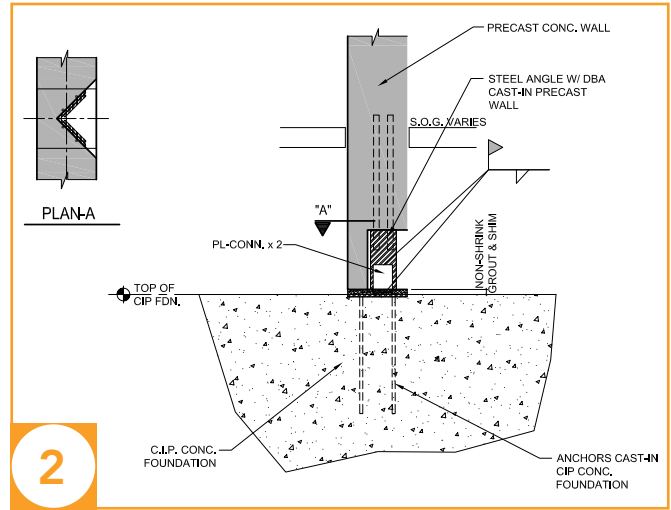

Section-Precast Wall Base

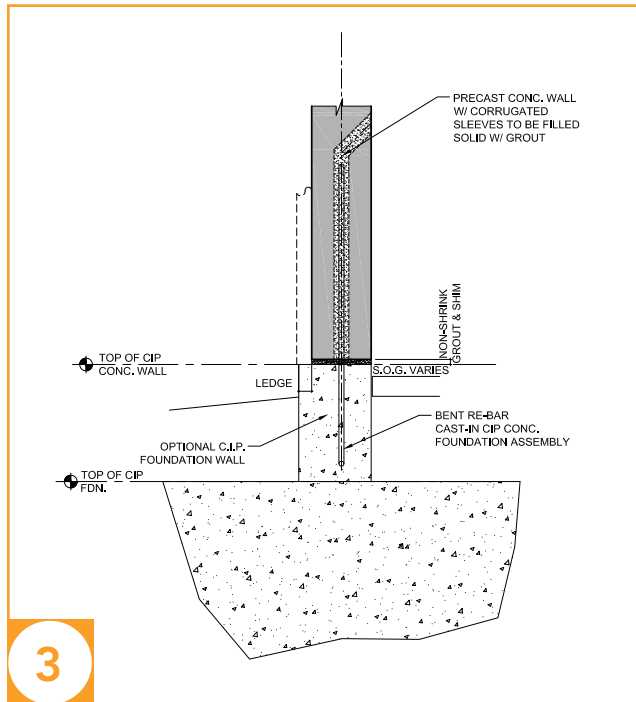

Precast wall to Exterior Foundation

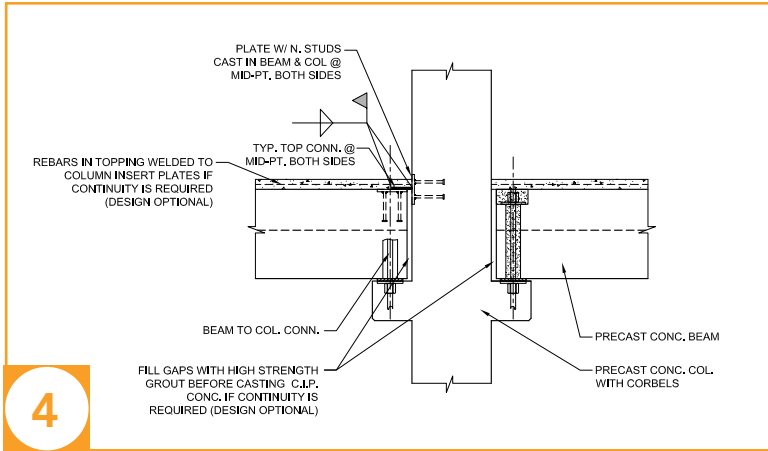

Beam on Continuous Column

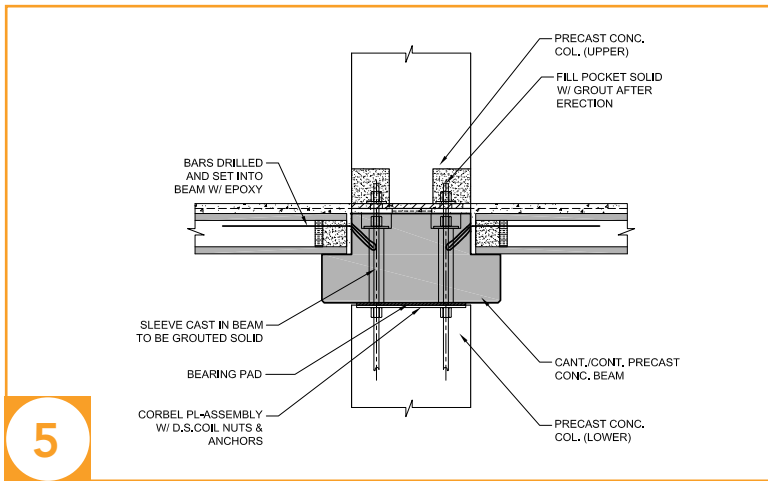

Cantilever or Continuous Beam / Column Connection

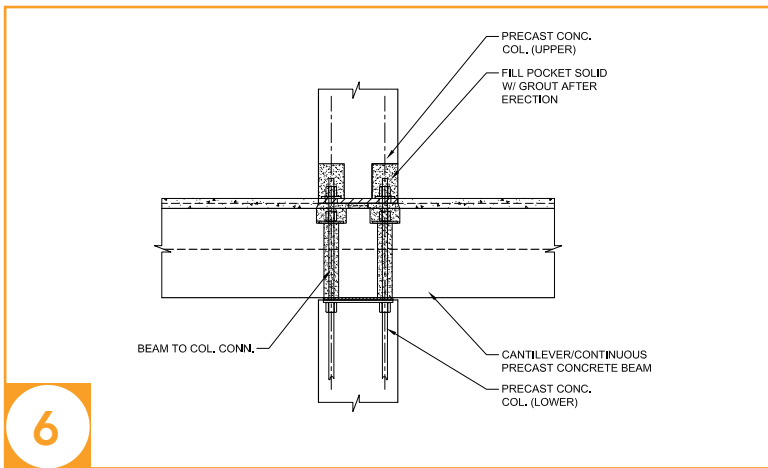

Continuous/Cantilever Beam to Column Connection

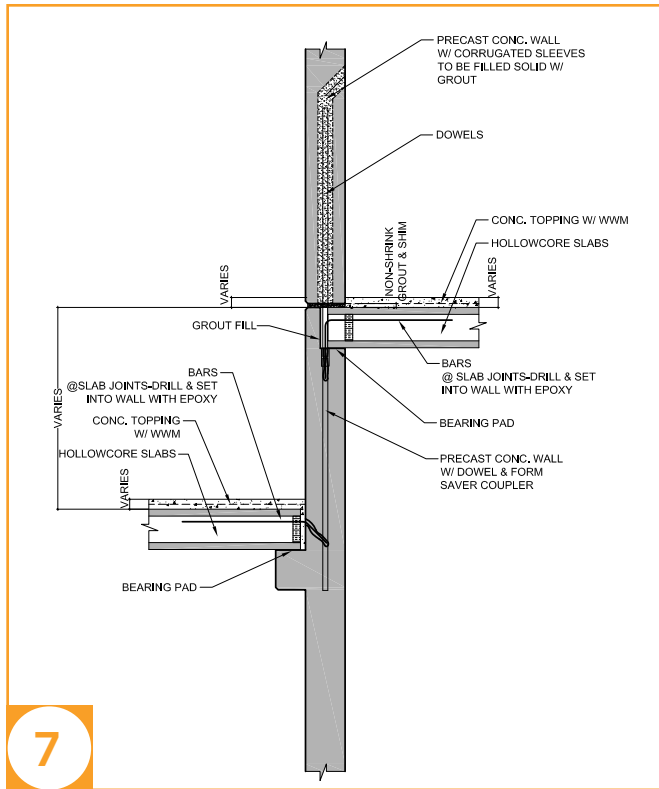

Wall to Floor Connection at Interior Variable Levels

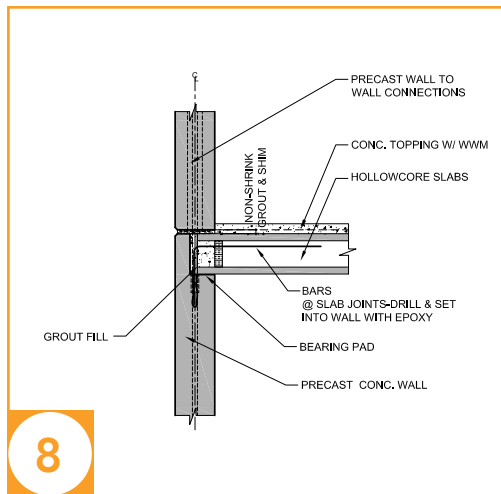

Exterior Wall To Floor w/ Ledge

Note: Exterior walls can be insulated walls or solid as per architectural requirements

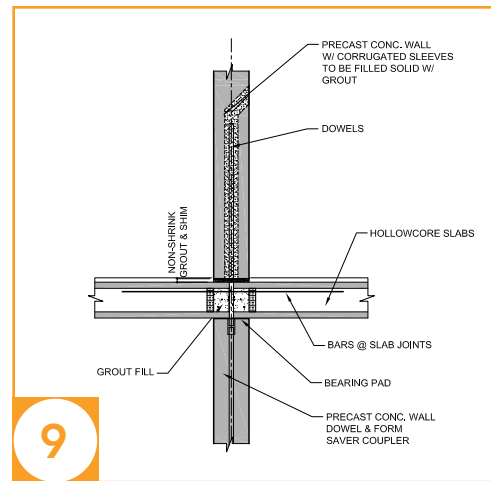

Interior Wall to Floor Connection

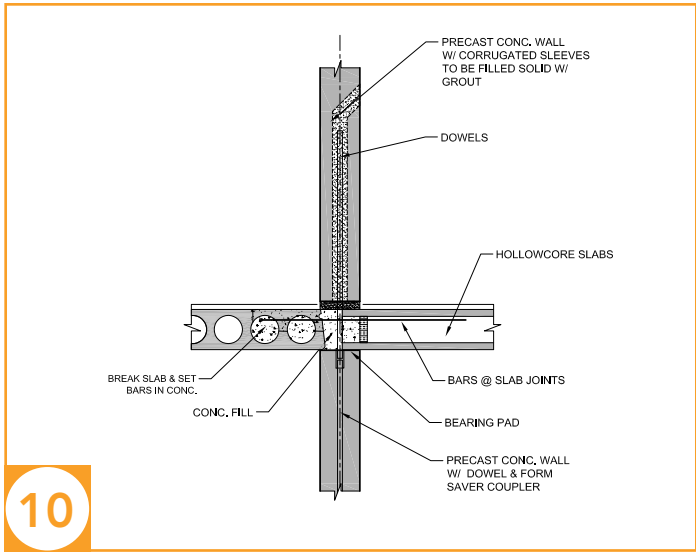

10

Interior Wall to Floor Connection 2

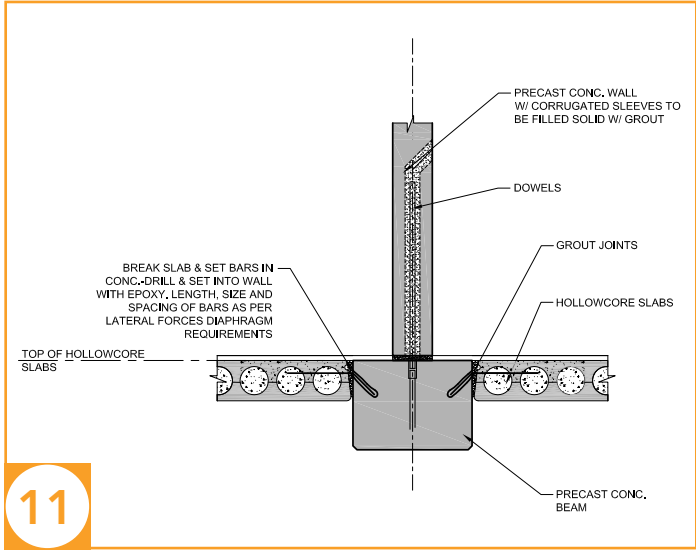

11

Beam/Wall/Floor

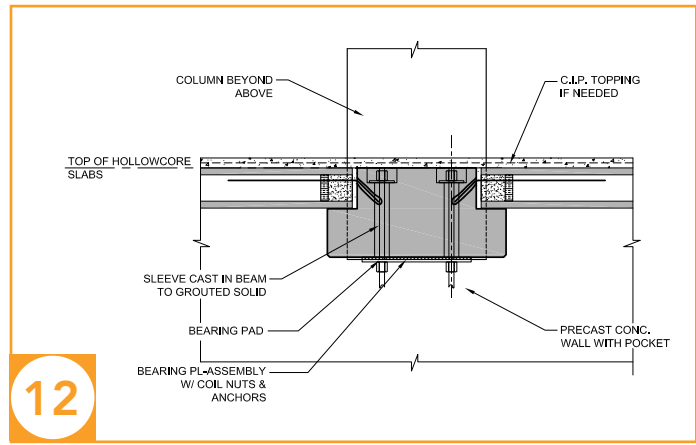

12

Beam/Slab/Column/Wall Assembly

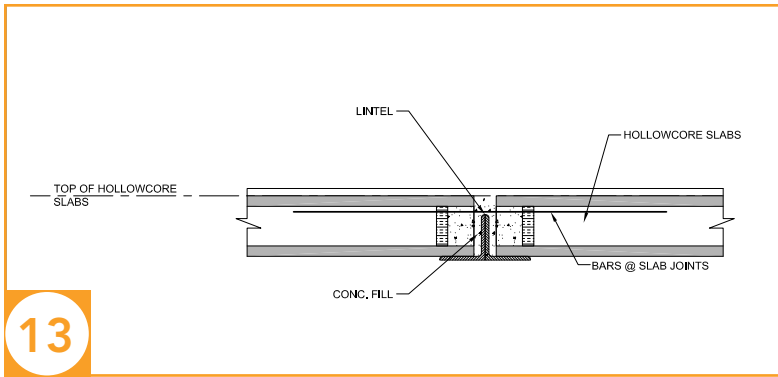

Interior Steel Lintel

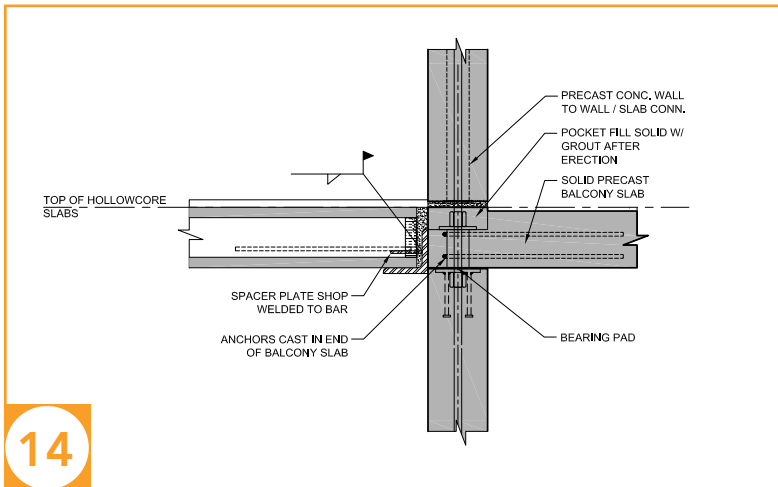

Balcony with Exterior Wall

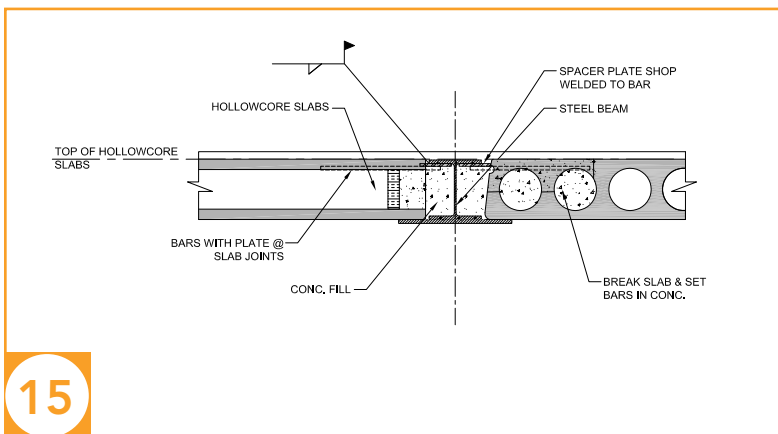

Hollowcore Slab to Lintel Connection 2



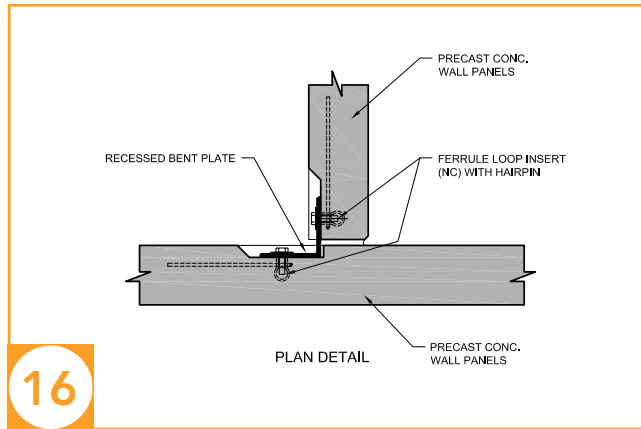

16  
Wall/Wall Connection

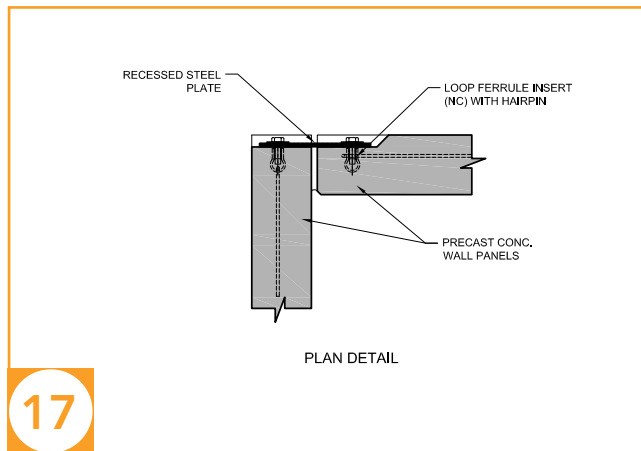

17  
Wall/Wall Connection—Exterior Corner detail

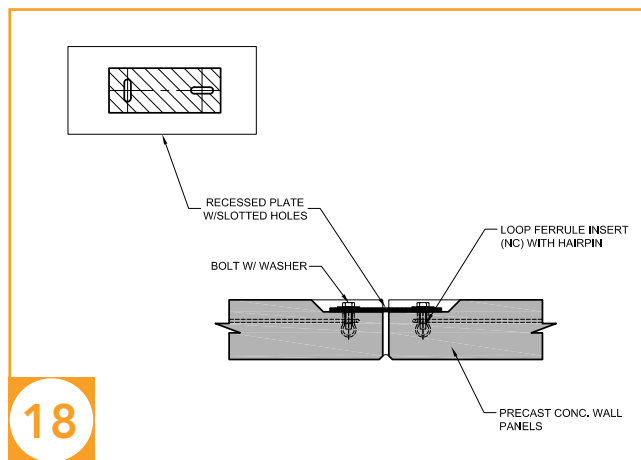

18  
Wall to Wall Connection

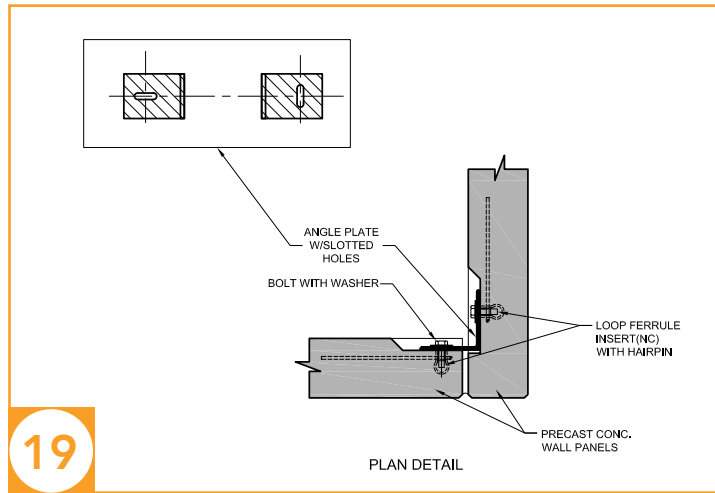

19 Wall to Wall Connection—Interior Corner Detail

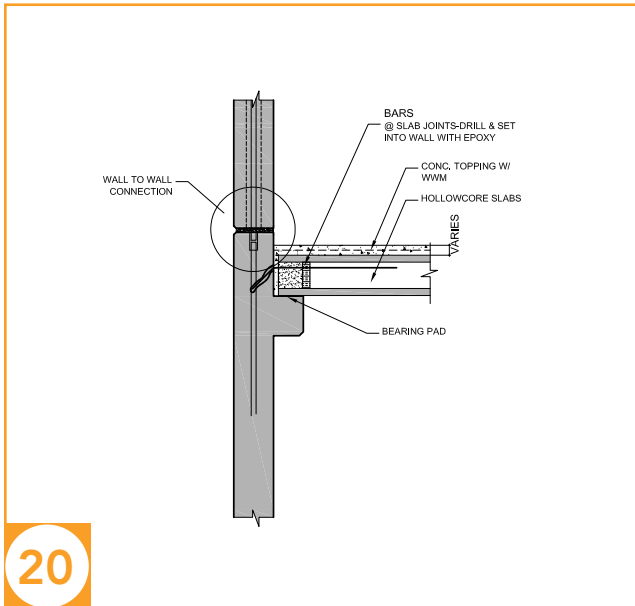

20 Exterior wall w/ Corbel to Slab Connection

Note: Exterior walls can be insulated walls or solid as per architectural requirements

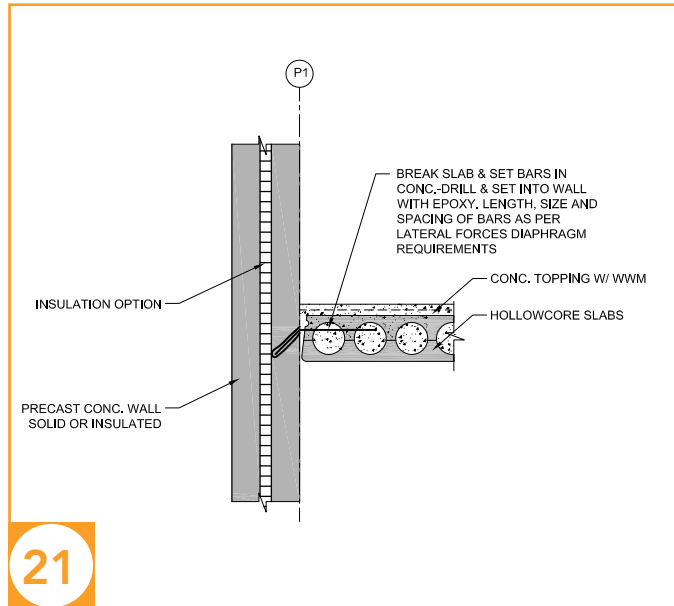

21 Exterior Wall to Non-Bearing Slab Connection

# Stadiums and Arenas

Large stadiums and arenas are impressive structures. Often these projects are built on tight schedules to accommodate imminent sporting events. Precast prestressed concrete has been the overwhelming choice for these projects. The technique of post-tensioning precast segments together has allowed this versatile material to form complex cantilever arm and ring beam systems to support the large roofs of these structures. Long-spans and the ability to eliminate costly site formwork makes precast and prestressed concrete the best choice for stadium construction. Mass produced precast seating units are manufactured in a variety of configurations and spans to provide quick installation and long lasting arena structures.



Pedestrian ramps, concession areas, restrooms, and dressing room areas can all be framed and constructed using precast prestressed concrete elements. Construction of stadium components that are difficult to cast-in-place, such as raker beams and ring beams, can be simplified by precasting these units in a pre-cast plant, delivering them to the site and lifting them into place. Consult local CPCI members for assistance in determining cost efficient solutions for the structure and stadia seating units.





---

## STADIUM

---



---

## DETAIL DRAWINGS

---

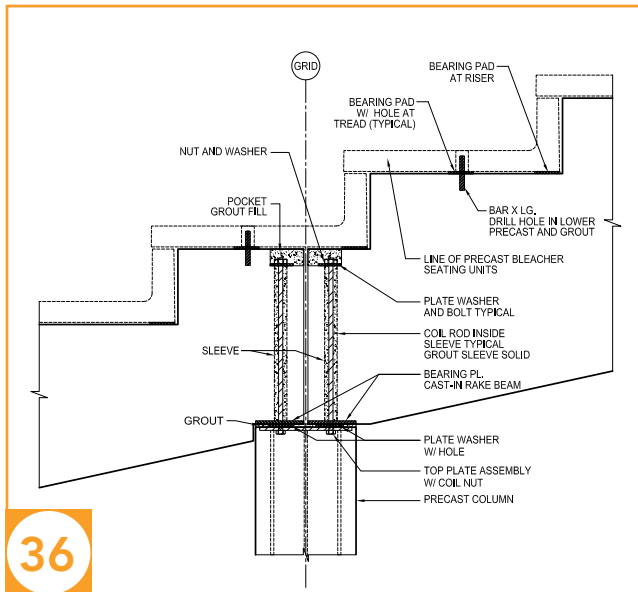

36

Raker Beam to Column

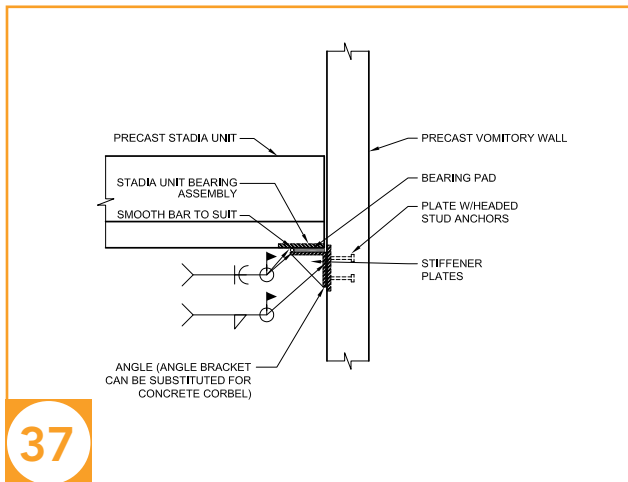

37

Stadia to Vomitory Wall Connection

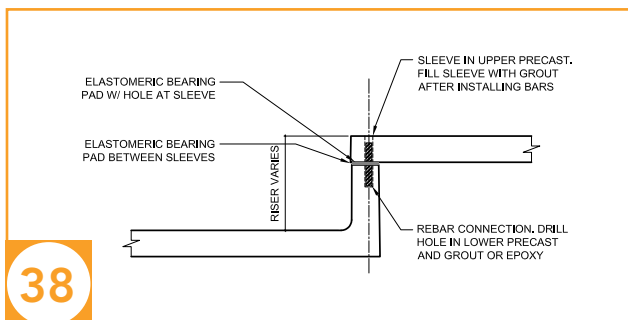

38

Typical Stadia Seating Connection

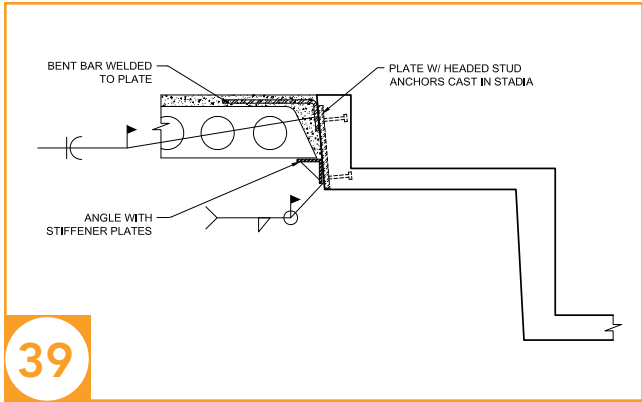

39

Stadia to Floor Connection

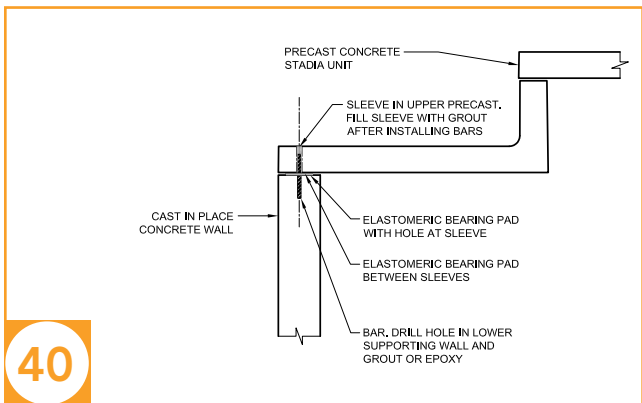

40

Lower Seating to Cast in Place Wall

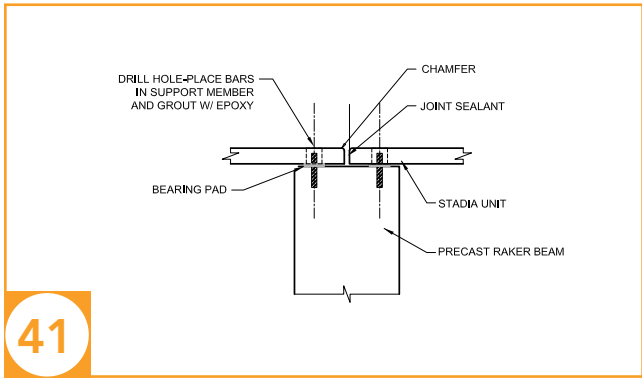

41

Stadia Seating to Raker Beam

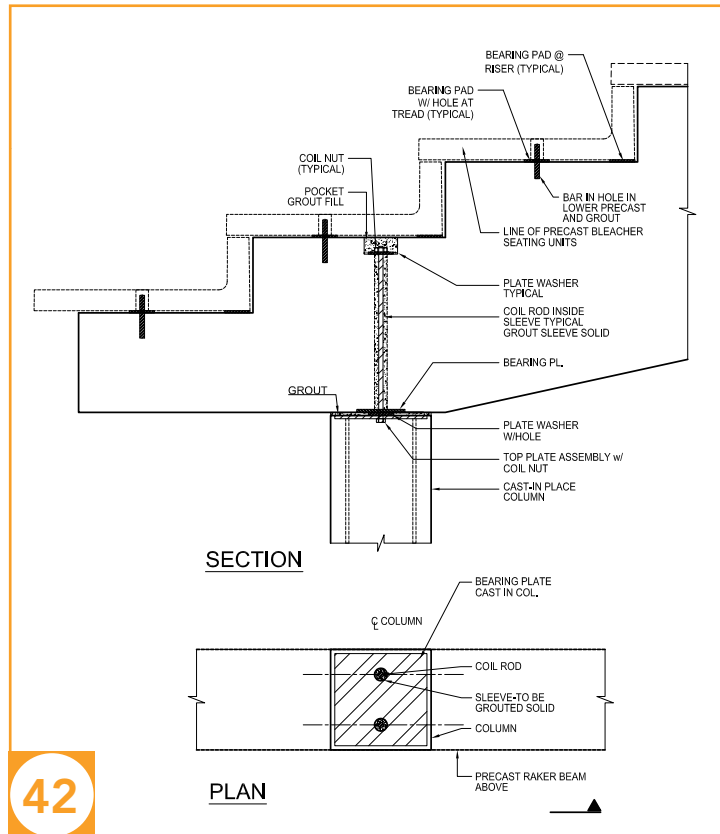

42

Raker Beam to Column

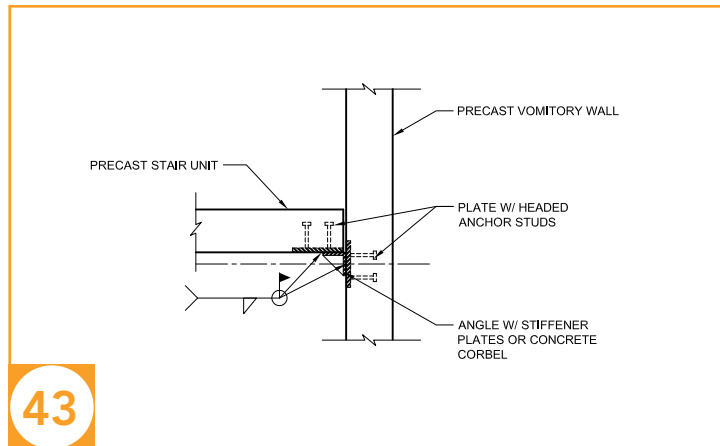

43

Stair to Vomitory Wall



# CPCI Members



## Institute:

The Canadian Precast/Prestressed Concrete Institute (CPCI) is a nonprofit corporation founded in 1961 for the purpose of advancing the design, manufacture and use of structural, architectural and specialty precast prestressed concrete in Canada.

- CPCI is unique—a combination of a manufacturing, trade and professional association, with a representative mix of companies and individuals.
- Membership includes precast producers (Active Members), industry suppliers (Associate and Supporting Members), engineers and architects (Professional Firm and Professional Individual Members), plus affiliate and student members.
- These members receive technical information from CPCI and PCI (USA).
- Consult the CPCI website ([www.cpci.ca](http://www.cpci.ca)) for more information and application forms.

## Technology:

CPCI members are committed to developing innovative solutions to meet the demands of the construction industry. CPCI is a source for knowledge, statistics, ideas and information relating to the design, manufacture, and use of precast prestressed concrete. Through investigations and research, new engineering processes are established to ensure quality and new product design. CPCI's aim is to improve the efficiency and effectiveness of the industry as a whole.

## CPCI Members:

CPCI member companies are precast professionals capable and willing to help you successfully complete your next project. Involve your CPCI partner at the early stages of project planning. Whether the challenges are structural, aesthetic, timing or economic, CPCI members can provide invaluable input. You will find CPCI members are dedicated, committed and competent to contribute to the realization of the standards you have set for your projects. They will be there to advise and assist you from concept to completion. Consult the CPCI website: [www.cpci.ca](http://www.cpci.ca) for members near you.

# CPCI Resources

## CPCI Guide Specifications

Download these specifications at: [www.cpci.ca](http://www.cpci.ca) — click on: Specifications

- Section 03 41 13 – Precast Concrete Hollowcore Planks
- Section 03 41 00 – Structural Precast Concrete
- Section 03 45 00 – Architectural Precast Concrete

These online specifications are updated to reflect changes in codes, standards and industry practices.

## Detailed Design Information:

### CPCI Design Manual

Manual contains comprehensive design and construction information in accordance with industry practice and Canadian design and construction codes and standards. Order from: [www.cpci.ca](http://www.cpci.ca)

### Designer's Knowledge Bank

The Designer's Knowledge Bank is a site created to assist design and construction professionals to understand precast-prestressed concrete products and structures. The material is free-of-charge and downloadable. Other material such as comprehensive hardcover design manuals may also be purchased through this site.

To access the Designer's Knowledge Bank, go to: [www.cpci.ca](http://www.cpci.ca)

## CPCI Members Near You and Your Project

To contact CPCI members go to: [www.precastsearch.com](http://www.precastsearch.com)

## Other CPCI Resources

- CPCI Total Precast e-brochure.
- CPCI Projects of the Month.
- CPCI Insulated Precast Wall Panel Technical Brochure.
- CPCI Structural Floor and Roof Technical Brochure.
- CPCI Precast Infrastructure/Bridge applications DVD.
- CPCI Research such as the Life Cycle Assessment Study and the Hollowcore Shear Capacity Research from the University of Manitoba.

## Other PCI Resources [www.pci.org](http://www.pci.org)

- PCI Hollowcore Design Manual.
- PCI Parking Structures Design and Construction Manual.
- Peer-reviewed technical papers as published in the PCI JOURNAL.

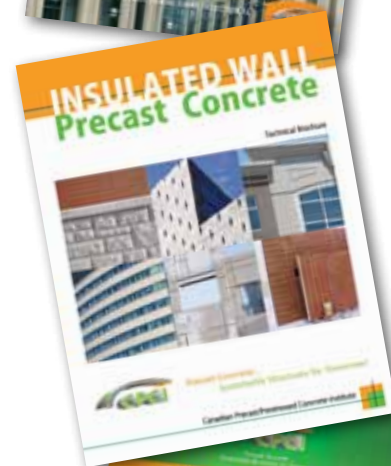



## How Precast Certification is a Requirement of the National Building Code of Canada

### National Building Code of Canada (2010) – Division B:

Clause 4.3.3.1.(1) – Buildings and their structural members made of plain, reinforced and prestressed concrete shall conform to CSA A23.3, Design of Concrete Structures.

Clause A-4.3.3.1.(1) - Precast Concrete- CSA A23.3, Design of Concrete Structures, requires precast concrete members to conform to CAN/CSA-A23.4, Precast Concrete – Materials and Construction.

CSA A23.3 – Design of concrete structures:

CSA-A23.3-04 (R2010) - Clause 16.2.1 – All precast concrete elements covered by this standard shall be manufactured and erected in accordance with CSA A23.4.

### CSA A23.4 – Precast concrete – Materials and construction:

CSA-A23.4-09 - Clause 4.2.1 – Precast concrete elements produced and erected in accordance with this standard shall be produced by certified manufacturers, with certification demonstrating the capability of a manufacturer to fabricate precast concrete elements to the requirements of this Standard.

**It is not a requirement of the National Building Code, Provincial Building Codes or CSA Standards that products and systems are required to be certified by CSA, only in accordance with CSA.**

## CPCI Precast Concrete Certification Program for Structural, Architectural and Specialty Precast Concrete Products and Systems

The CPCI certification program is designed to qualify manufacturers who fabricate structural, architectural and specialty precast concrete.

Manufacturers must meet the requirements of CSA Standard A23.4, including Annexes A and B, together with PCI MNL-116 and 117 and CPCI certification requirements.

Manufacturers are evaluated on their quality system, documentation, production procedures, management, engineering, personnel, equipment, finished products and assemblies. Independent professional engineers conduct two-day audits twice annually.

Certification confirms a manufacturer's capability to produce quality products and systems.

The CPCI Certification Program assures project specifiers and owners of a Manufacturer's comprehensive in-house quality assurance program and acceptable production methods.

### Purpose

The purpose of the audit program is to provide owners and designers with manufacturers who are:

- Qualified to manufacture the products they supply to the marketplace
- Competent to provide quality precast with adequate personnel and facilities
- Committed to improving the quality of their products and systems

### Quality Audits are the heart of the precast certification program

- Audits ensure manufacturers have a quality system in place that is consistently adhered to
- Audits ensure adherence to national standards
- Audits ensure adherence to requirements of the precast certification program
- Audits evaluate and identify areas requiring upgrading or corrective action (continual improvement)

---

# Infrastructure **LIFE**

for

---



## Canadian Precast/Prestressed Concrete Institute

196 Bronson Avenue, Suite 100, Ottawa, Ontario K1R 6H4

Telephone (613) 232-2619 Fax: (613) 232-5139

Toll Free: 1-877-YES-CPCI (1-877-937-2724)

E-mail: [info@cpci.ca](mailto:info@cpci.ca)