



**DESIGN OF SHORT COLUMNS ACCORDING TO
ACI 318-11 AND BS 8110-97: A COMPARATIVE
STUDY BASED ON CONDITIONS IN NIGERIA**

A THESIS SUBMITTED TO
THE GRADUATE SCHOOL OF APPLIED SCIENCES
OF
NEAR EAST UNIVERSITY

by

SAMIR BASHIR

In Partial Fulfillment of the Requirements
for the Degree of Master of Science
in Civil Engineering

NICOSIA 2014



**Samir Bashir: DESIGN OF SHORT COLUMNS ACCORDING TO ACI 318-11 AND
BS 8110-97: A COMPARATIVE STUDY BASED ON CONDITIONS IN NIGERIA**

**Approval of Director of Graduate School of
Applied Sciences**



Prof. Dr. İlkey SALIHOĞLU

**We certify that this thesis is satisfactory for the award of the degree of Masters of
Science in Civil Engineering**

Examining Committee in Charge:

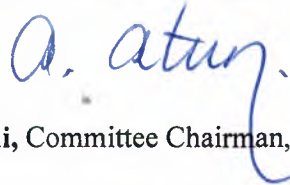
Prof Dr Ata Atun, Supervisor, Civil Engineering Department, NEU.



Assoc. Prof. Dr. Kabir Sadeghi, Committee Chairman, Faculty of Engineering, GAU



Asst. Prof. Dr Pinar Akpınar, Committee Member, Civil Engineering Department, NEU.



I hereby declare that all information in this document has been obtained and presented in accordance with academic rules and ethical conduct. I also declare that, as required by these rules and conduct, I have fully cited and referenced all materials and results to this work.

Name, Surname: SAMIR BASHIR

Signature: 

Date: 15/07/2014.

ACKNOWLEDGEMENTS

All praise is for Allah, lord of all that exists. Oh Allah, send prayers and salutations upon our beloved prophet Muhammad, his family, his companions and all those who follow his path until the last day.

My profound gratitude and deep regards goes to my supervisor, Prof. Ata Atun for his guidance and encouragement throughout the course of this thesis. His tireless efforts made this thesis a success.

My deepest appreciation also goes to my parents, family and friends (whose names are too many to mention in this context) who stood by me throughout my life endeavors.

I also want to thank the people and government of Kano State, my state under the leadership of Engr. Rabi'u Musa Kwankwaso for giving me this rare opportunity to further my studies.

Dedicated to the loving memory of my late siblings Khadijah and Muhammad, may
Aljannatul Firdaus be their final abode, Amin.

ABSTRACT

In the absence of a national design code, structural engineers in Nigeria use BS 8110, Euro code 2, ACI 318 and quite a number of other structural design codes for the design of reinforced concrete structures. The principles and design approaches of these codes differ from one another. Also, some codes are more economical than others.

This study compared BS 8110-97 and ACI 318M-11 in terms of the design of short column with particular emphasis on the area of longitudinal reinforcements required, with the aim of determining which of the two codes provides the most economic design. The super-structure of a seven storey reinforced concrete hospital building was modeled and analysed using SAP 2000 program taking into account only dead and live loads and assuming only one scenario (full) for live loads; the result of the analysis was used to design the columns with the aid of Prokon 32 suite of programmes.

The percentage difference between the areas of steel required by the two codes was calculated with the BS code as the base line. The average percentage difference for all columns was found to be about -3% indicating that the ACI 318M-11 code requires less amount of reinforcement.

Keywords: *Short Columns, Area of Steel Required, BS 8110-97, ACI 318M-11, Prokon 32*

ÖZET

Ulusal bir plan tüzüğü olmadığından dolayı Nijerya'daki mühendisler güçlendirilmiş beton binaların planı için BS 8110, Euro code 2, ACI 318 ve çok sayıda diğer yapısal tasarım planlarını kullanırlar. Bu planların prensipleri, ilkeleri ve tasarım yaklaşımları birbirlerinden farklıdır. Aynı zamanda bazı planlar diğerlerinden daha ekonomiktirler.

Bu çalışma bu iki plandan hangisinin en ekonomik olduğunu belirlemek amacıyla özellikle boylamasına (dikey) güçlendirmeye dikkat çekerek kısa kolon tasarımı bakımından BS 8110-97 ve ACI 318M-11 planlarını karşılaştırmıştır. Yedi katlı güçlendirilmiş beton hastane yapısı model alınmıştır ve sadece ölü (kalıcı) ve hareketli yük dikkate alınarak ve hareketli yük için sadece bir senaryo kabul edilerek SAP 2000 programı kullanılarak incelenmiştir; analiz sonuçları Prokon 32 programının yardımıyla kolonları tasarlamakta kullanılmıştır.

İki kolonun gereksinimi olan çelik alanındaki yüzdelik farkı ana hat olarak BS koduyla hesaplanmıştır. Her kolon için ortalama yüzdelik farkı -3% civarında bulunmuştur. Bu da ACI 318M-11 planının daha az desteğe ihtiyaç duyduğu anlamına gelmektedir.

Anahtar Kelimeler: *Kısa kolonlar, çelik gereksinimi olan alanlar, BS 8110-97, ACI 318M-11, Prokon 32*

TABLE OF CONTENTS

ACKNOWLEDGEMENTS	ii
ABSTRACT	iv
ÖZET	v
TABLE OF CONTENTS	vi
LIST OF FIGURES	ix
LIST OF TABLES	x
LIST OF ABBREVIATIONS	xi
LIST OF SYMBOLS	xii
 CHAPTER 1 : INTRODUCTION	
1.1 Background of the Study	1
1.2 Objectives	1
1.3 Works Done.....	2
1.4 Guides to the Thesis	2
 CHAPTER 2 : BACKGROUND AND LITERATURE REVIEW	
2.1 Introduction	3
2.2 Previous Studies	4
2.3 Column	9
2.3.1 Short Columns	12
2.4 BS 8110-97	15
2.4.1 Limit-States Design	15
2.4.2 Partial Factors of Safety for Materials	16
2.4.3 Partial Factors of Safety for Loads	16
2.4.4 Load Combinations	17
2.5 BS 8110-97 Code Requirements for Short Columns	17
2.5.1 Braced and Unbraced Columns	18
2.5.2 Effective Height of a Column	18
2.5.3 Minimum Eccentricity	19
2.5.4 Minimum Number of Longitudinal Bars in Columns	19
2.5.5 Spacing of Reinforcement	20

2.5.6 Percentage of Longitudinal Reinforcement	20
2.5.7 Size and Spacing of Links	21
2.5.8 Arrangement of Links	21
2.5.9 Concrete Cover to Reinforcement	21
2.5.10 Nominal Maximum Size of Aggregate	22
2.6 Short Column Design According to BS 8110-97	22
2.6.1 Short Axially Loaded Column	22
2.6.2 Short Uniaxially Loaded Columns	24
2.6.3 Short Biaxially Loaded Columns	25
2.7 ACI 318M-11	27
2.7.1 Strength Design Method	27
2.7.2 Load Combinations	27
2.7.3 Strength Reduction Factors	28
2.8 ACI 318M-11 Code Requirements for Short Columns	28
2.8.1 Percentage of Longitudinal Reinforcement	28
2.8.2 Minimum Number of Longitudinal Bars in Columns	29
2.8.3 Clear Distance between Reinforcing Bars	29
2.8.4 Lateral Ties	29
2.8.5 Vertical Spacing	30
2.8.6 Spirals	30
2.9 Short Column Design According ACI	31
2.9.1 Short Axially Loaded Column	31
2.9.2 Short Uniaxially Loaded Column	32
2.9.3 Short Biaxially Loaded Column	34
2.10 General Climate of Nigeria	38
2.10.1 Climatic Conditions in Kano Nigeria	38
CHAPTER 3 : METHODOLOGY	
3.1 Introduction	40
3.2 Geometry of the Building	41
3.3 Assigning Column ID	42

3.4 Preliminary Design	43
3.4.1 Member Sizing	43
3.4.2 Gravity Loads	45
3.4.3 Wind Load	46
3.5 Sizing of Columns	47
3.6 Structural Analysis	48
3.6.1 Modeling of the Structure	49
3.6.2 Defining Material and Member Section Properties	49
3.6.3 Defining Load Patterns and Assigning Load Magnitudes	50
3.6.4 Running the Analysis	50
3.7 Method of Design	51
CHAPTER 4 : RESULTS AND DISCUSSION	
4.1 Comparison of Column Design Output	53
4.2 Comparison of Area of Steel Required For Corner Columns	53
4.2.1 Percentage Difference in Area of Steel Required For Corner Columns	53
4.3 Area of Steel Required for Side Columns	55
4.3.1 Percentage Difference in Area of Steel Required for Side Columns	55
4.4 Comparison of Area of Steel Required for Inner Columns	57
4.4.1 Percentage Difference in Area of Steel Required for Inner Columns	57
4.5 Discussion of Results	58
CHAPTER 5 : SUMMARY, CONCLUSIONS AND RECCOMMENDATIONS	
5.1 Summary and Conclusions	60
5.2 Recommendations	61
REFERENCES	62
APPENDIX	66

LIST OF FIGURES

Figure 2.1: Tied Column	10
Figure 2.2: Spiral Column	11
Figure 2.3: Composite Column	12
Figure 2.4: Column Types.....	14
Figure 2.5: Braced Columns	18
Figure 2.6: Column Design Chart	25
Figure 2.7: Biaxially Loaded Column	26
Figure 2.8: Column Interaction Diagram	33
Figure 2.9: Notations Used for Column Sections Subjected to Biaxial Bending	34
Figure 2.10 a and b: Interaction Surfaces for the Reciprocal Method	36
Figure 3.1: Floor Plan of the Building	41
Figure 3.2: Elevation of the Building.....	42
Figure 3.3 Column Identification	43
Figure 3.4: 3D Model of the Building.....	49
Figure 3.5: Axial Forces on Columns	50
Figure 3.6 Prokon Input GUI	52
Figure 4.1: Area of Steel Required for Column C03 (Side Column).	55
Figure 4.2: Area of Steel Required for Column C07 (Corner Column)	56
Figure 4.3: Area of Steel Required for Column C09 (Inner Column).	58

LIST OF TABLES

Table 2.1: Material Partial Factors Of Safety (γ_m) At The Ultimate Limit State	16
Table 2.2: Load Combination and Partial Factors of Safety for Loadings	17
Table 2.3: Values Of β for Braced Columns	19
Table 2.4: Values Of β for Unbraced Columns	19
Table 2.5: Minimum and Maximum Column Longitudinal Steel Ratio	20
Table 2.6: Load Combinations	27
Table 2.8: ACI Strength Reduction Factors	28
Table 2.9: Minimum and Maximum Column Longitudinal Steel Ratio ($P = A_{st}/A_g$)	29
Table 3.1: General Building Information	40
Table 4.1: Percentage Difference in Area of Steel Required for Corner Columns.	54
Table 4.2: Area of Steel Required for Column C03 (Side Column).	54
Table 4.3: Percentage Difference in Area of Steel Required for Inner Columns.	55
Table 4.4: Area of Steel Required for Column C07 (Corner Column).	56
Table 4.5: Percentage Difference in Area of Steel Required for Side Columns.	57
Table 4.6: Area of Steel Required for Column C09 (Inner Column).	57

LIST OF ABBREVIATIONS

ACI	American Concrete Institute
ACI 318-11	Building Code Requirements for Structural Concrete
ASCE 7-10	Minimum Design Loads for Buildings and Other Structures
BS 8110	Structural Use of Concrete
BS 6399	Loadings for Buildings
EC	Eurocode
EC2	Eurocode 2 (Design of Concrete Structures)
UAC	Unified Arabic Code
CSA-A23.3-94	Canadian Code

LIST OF SYMBOLS

A	Net concrete area
A_c	Net cross-sectional area of concrete in a column.
A_g	Gross section area of column section.
A_q	Total steel compressive areas
A_{sc}	Area of vertical reinforcement.
b	Width of a column (dimension of cross-section perpendicular to h).
b_{min}	Minimum dimension of the column
d	Effective depth
D	Specified Dead Load
e	Eccentricity of axial load on a column
f_c	Specified compressive strength of concrete
f_y	Characteristic strength of reinforcement
G_k	Characteristic dead load
h	Depth of cross-section measured in the plane under consideration.
h_{agg}	Maximum size of the aggregate
k	Effective length factor
L	Live load
l	Height of column measured between centres of restraints
l_e	Effective height of a column in the plane of bending considered.
l_{ex}	Effective height in respect of the major axis.
l_{ey}	Effective height in respect of the minor axis.
l_o	Clear height between end restraints
L_r	Roof live load
l_u	Unsupported length
M	Moment due to factored loads
M₁	Smaller factored end moment on column.
M₂	Larger factored end moment on column, always positive.
M₁	Smaller factored end moment on a column
M_{add}	Additional design ultimate moment induced by deflection of column.

LIST OF SYMBOLS

A	Net concrete area
A_c	Net cross-sectional area of concrete in a column.
A_g	Gross section area of column section.
A_q	Total steel compressive areas
A_{sc}	Area of vertical reinforcement.
b	Width of a column (dimension of cross-section perpendicular to h).
b_{min}	Minimum dimension of the column
d	Effective depth
D	Specified Dead Load
e	Eccentricity of axial load on a column
f_c	Specified compressive strength of concrete
f_y	Characteristic strength of reinforcement
G_k	Characteristic dead load
h	Depth of cross-section measured in the plane under consideration.
h_{agg}	Maximum size of the aggregate
k	Effective length factor
L	Live load
l	Height of column measured between centres of restraints
l_e	Effective height of a column in the plane of bending considered.
l_{ex}	Effective height in respect of the major axis.
l_{ey}	Effective height in respect of the minor axis.
l_o	Clear height between end restraints
L_r	Roof live load
l_u	Unsupported length
M	Moment due to factored loads
M₁	Smaller factored end moment on column.
M₂	Larger factored end moment on column, always positive.
M₁	Smaller factored end moment on a column
M_{add}	Additional design ultimate moment induced by deflection of column.

M_i	Initial design ultimate moment before allowance for additional design
M_{min}	Moment minimum
M_n	Nominal moment strength
M_x	Design ultimate moment about the x-axis.
M_x'	Effective uniaxial design ultimate moment about the x-axis.
M_y'	Effective uniaxial design ultimate moment about y- axis
M_y	Design ultimate moment about the y-axis
n	Number of columns resisting sideways at a given level or storey.
N	Design ultimate axial load on a column.
N_{bal}	Design axial load capacity of a balanced section symmetrically- reinforced rectangular sections
N_{uz}	Design ultimate capacity of a section when subjected to axial load only.
ϕ	Strength reduction factor
ρ_g	Ratio of total reinforcement area to cross-sectional area of column
Q_k	Characteristic imposed load
r	Radius of gyration associated with axis about which bending occurs.
R_n	Nominal resistance for the concrete design
S	Vertical spacing of ties
V	Nominal shear force carried by concrete
W	Wind load
M_i	Initial design ultimate moment before allowance for additional design

CHAPTER 1

INTRODUCTION

1.1 Background of the Study

The design of reinforced concrete members such as slabs, beams, columns and foundations is generally done within the framework of design codes. While some countries or regions have developed their own national codes, other countries do not employ the use of specific design codes. Structural engineers in these countries often resort to consulting national codes from other countries. In Nigeria even though BS8110-97 is widely used for reinforced concrete design, many other codes such ACI 318 and Eurocode 2 are also being used.

Although the main purpose of these design codes is to provide guidelines for the design of safe and economic structures; the principles, procedures and assumptions employed to achieve this may differ from one code to another. Studies have also shown that some codes are more economical than others.

1.2 Objectives

- To design the columns (short) of a reinforced concrete seven storey hospital building according to BS 8110-97 and ACI 318M-11.
- To compare the column design output obtained (with emphasis on the Area of steel required).
- To determine which code provides the most economical design.

1.3 Works Done

In order to achieve the objectives of this study, the following works were carried out:

- A seven storey reinforced concrete building was modeled and analysed using SAP 2000 program.
- The forces acting on the columns obtained from the analysis result were used to design the columns according to the two codes using Prokon suite program.
- The design outputs for both codes were compared to ascertain which code provides the most economical design.

1.4 Guides to the Thesis

The thesis comprises of five chapters; chapter one which states the problem addressed by the research and discusses some background to the problem. It also highlights the objectives and achievements of the research.

Chapter two includes the literature review of similar researches that were previously carried out. A theoretical background to short column and the design requirements according to these “codes” that are being studied in the research were also presented in this chapter.

Chapter three gives the methodology that was followed in order to achieve the objectives of the research, Chapter four presents the results of analysis and design conducted. The results were discussed and compared in this chapter.

The last chapter (five) concludes the research; recommendations were made in this chapter.

CHAPTER 2

BACKGROUND AND LITERATURE REVIEW

2.1 Introduction

Structural design refers the selection of materials, size, type and the suitable configuration that could carry loads in a safe and serviceable fashion. In general, it is the engineering of stationary objects such as bridges and buildings.

The design of concrete structures such as slabs, beams, columns and foundations is generally done within the framework of codes giving specific requirements for materials, structural analysis, member proportioning, etc. These codes are often referred to as design codes. They are legal documents which represent the minimum requirements for obtaining safe structures and are written by responsible people with wide knowledge and experience of engineering. There are many structural design codes that are being used in different regions or countries across the globe, for example, Turkish standards (TS 500), Unified Arabic Code (UAC), Canadian Code (CSA-A23.3-94), Eurocode 2 (EC), BS 8110 and also American Code (ACI 318) among others. While some countries or regions have developed their own national or international codes, for example Eurocode used by countries across Europe and ACI 318 in the USA, other countries (mostly developing) do not employ the use of specific design codes. Structural engineers in these countries often resort to consulting national codes from other countries.

In the absence of a national design code, the structural engineers in Nigeria use the BS 8110, Euro code 2, ACI 318 and quite a number of structural design codes to design structures. They find these codes useful for complying with the legal stipulations there. However, designers and project owners frequently compare the stipulations in these codes seeking points of similarities and differences.

Although the main purpose of these design codes is to provide guidelines for the design of safe and economic structures, the principles, procedures and assumptions employed to achieve this may differ from one code to another. Also studies have shown that some codes are more economical than others.

Engineering is all about the design and construction of safe structures which meets all quality requirements at lowest possible cost. Even if a structure is safe, it may not necessarily be regarded as a successful engineering structure unless it is also economical i.e. in engineering safety and economy goes hand in hand.

Comparative studies of these differences helps in better understanding and interpretation of these codes. It will also help the structural engineer to choose which code is more economical for the design of an intended structure.

2.2 Previous Studies

Over the years several researches have been conducted in order compare the design requirements of different structural components such as beams, columns and slabs according to different concrete design codes.

Most of these studies employ a similar methodology in trying to achieve the research objectives, the general provisions or requirements for the design of the structural members according to the codes to be studied are compared theoretically, Procedural similarities and or differences are highlighted and then sample members are designed as per the design codes and conclusion is drawn as to which of the codes is more economical, usually taking into account the area of steel required. For purpose of this study, a review of such papers mostly journals and thesis was conducted and a brief summary of some of these publications is presented below;

- Alnuaimi et al. (2012) "*Design Results of RC Members Subjected to Bending, Shear, and Torsion Using ACI 318: 08 and BS 8110: 97 Building Codes.*" In this study

Although the main purpose of these design codes is to provide guidelines for the design of safe and economic structures, the principles, procedures and assumptions employed to achieve this may differ from one code to another. Also studies have shown that some codes are more economical than others.

Engineering is all about the design and construction of safe structures which meets all quality requirements at lowest possible cost. Even if a structure is safe, it may not necessarily be regarded as a successful engineering structure unless it is also economical i.e. in engineering safety and economy goes hand in hand.

Comparative studies of these differences helps in better understanding and interpretation of these codes. It will also help the structural engineer to choose which code is more economical for the design of an intended structure.

2.2 Previous Studies

Over the years several researches have been conducted in order compare the design requirements of different structural components such as beams, columns and slabs according to different concrete design codes.

Most of these studies employ a similar methodology in trying to achieve the research objectives, the general provisions or requirements for the design of the structural members according to the codes to be studied are compared theoretically, Procedural similarities and or differences are highlighted and then sample members are designed as per the design codes and conclusion is drawn as to which of the codes is more economical, usually taking into account the area of steel required. For purpose of this study, a review of such papers mostly journals and thesis was conducted and a brief summary of some of these publications is presented below;

- Alnuaimi et al. (2012) "*Design Results of RC Members Subjected to Bending, Shear, and Torsion Using ACI 318: 08 and BS 8110: 97 Building Codes.*" In this study

carried out in Oman, a comparison of the amount of required reinforcement for design cases of rectangular beam sections subjected to combined loads of bending, punching shear at slab–column connections and shear and torsion using British Standards Institution (BSI) building codes and American Concrete Institute (ACI) taking into account the different safety factors for design loads stipulated by the codes.

It was observed that ACI code requires more steel reinforcement than BS code does when the codes' safety factors were not taken into account. However, when the load safety factors are considered in calculating the design loads, the area of reinforcement required for ACI code was found to be less than that found for BS code. The research also shows that for the same geometry, loading conditions and material; the punching shear strength of flat slab–column connections and the minimum area of flexural reinforcement required calculated using the BS code was found to be less than that calculated using the ACI code, while the reverse was the case for the minimum area of shear reinforcement.

The study finally recommends the BS code against the ACI code because of the lower steel reinforcement requirements, which leads to cheaper construction while still maintaining safety.

- Atiyah (2013) "*General Comparison And Evaluation Of TEC-2007 And EC8 Using Sta4-Cad V12.1 In Respect Of Cost Estimation*" This study compared the general design stipulations of Eurocode 8 and Turkish Earthquake code (TEC-2007). The study focused on the earthquake design of multi-storey reinforced concrete buildings which were modeled using a CAD program; STA4-CAD V12.1. A cost analysis of the results obtained indicates that the cost is almost the same when the buildings were designed according to both codes.
- Franklina and Mensahb (2011) "*A Comparative Study of EC2 and BS8110 Beam Analysis and Design in a Reinforced Concrete Four Storey Building.*" In this study,

the main beams of a multi storey reinforced concrete building were analyzed and designed according to EC2 and BS8110 using Prokon 32 suite of programmes. The bending moment diagrams for the critical continuous beam span for both codes before moment redistribution and after 10%, 20% and 30% redistribution were examined. Results indicated that for the negative bending moments at internal supports using the BS8110 values as baseline, the EC2 moments exceeded the BS8110 values by 0 to 8.5% at all levels of moment redistribution, for maximum span moments, the EC2 values lagged behind the BS8110 moments by about 4.5% to 9% for moment distributions up to 20%. At 30% distribution a lag of about 14.3% occurred in a specific case although this was felt to be an isolated example. An examination of the upper limit of the shear force envelopes at supports revealed that the BS8110 shears exceeded the EC2 ones by a margin of 2.4% to 5.4% in general. For the lower limit of the shear force envelopes the same trend was observed although the magnitude of BS8110's dominance was generally less than 2.5%.

Jamaludin (2010) presented a study "Comparative Studies Of Reinforced Concrete Beam Design Using BS 8110-97 And ACI 318-05.", in this study, moment and shear were kept constant for beams of different sizes. The beams were designed manually (hand calculations) using BS 8110-97 and ACI 318-05. Microsoft Office Excel was used in order to make calculations easier. Results obtained shows that design of beams Using ACI 318 is more economical than using BS 8110 in terms of the area of steel required, number of links and link sizes

Dorsey (2008) "Flexural comparison of the ACI 318-08 and AASHTO LRFD structural concrete codes." a paper which presents the findings of an investigation into the differences between the two most dominant concrete design codes in North America; ACI 318-08 and AASHTO LRFD with regard to the calculating the flexural strength of a section. The codes provisions on series of deep beams with openings and a shallow reinforced T-beam analyzed using the strut and the model method and classical methods respectively were compared. The study concluded that

- Liew (2009) “British standard (BS 8110) and Eurocode 2 (EC2) for reinforced concrete column design” The study carried out in Malaysia tried to address the perception designers over there have that design using EC2 is very difficult and that it is not very different from BS 8110. The study conducted a review of the design steps for column design using Eurocode 2. Several types of columns were designed according to the two codes and resulting area of steel reinforcements were compared. Results showed that although the design process of EC2 was more technical, they were still easy to understand and follow and design using EC2 was much more economical.
- Alnuaimi and Patel (2013) “Serviceability, limit state, bar anchorage and lap lengths in ACI318:08 and BS8110:97: A comparative study” This paper presents a comparative calculation study of the deflection, bar anchorage, lap lengths and control of crack width of reinforced concrete beams using the BS 8110 and ACI 318 codes. The deflections calculated using the BS code were smaller than those predicted by the ACI code, short-term deflection decreases with the increase in the dead-to-live load ratio whereas the long-term deflection increases for both codes. The study also showed the BS code maintains a constant bar spacing regardless of the concrete cover, but for the ACI code, it reduces with the increase in concrete cover. With increase in concrete strength, the tension anchorage length decreases for both codes. The BS code requires a greater anchorage length in compression than the ACI code does. The compression lap length requirement in the BS is more than that in ACI code for the concrete of compressive strength less than 37 MPa and the former stipulates longer lap lengths for higher concrete strengths.

It is clear from these references that most of the researches were not carried out in Nigeria and no comprehensive work was found in the literature comparing ACI 318M-11 and BS 8110-97 codes in terms of column design particularly short columns which are predominantly found in reinforced concrete buildings. Accordingly, a comparative study of the design of short columns of a four story reinforced concrete building modeled and analysed based on environmental conditions in Nigeria (Kano in particular) was conducted.

2.3 Column

A column is a vertical structural member with height considerably greater than its cross sectional dimensions which carries compressive loads transferred by the floors and roof then transmits these loads to the building foundations. They may be subjected bending either due asymmetrical loading from beams due to their slenderness. This bending may be about one or both axes of the column cross section. Columns may be circular or rectangular in shape.

Reinforced concrete columns are usually reinforced with transverse and longitudinal reinforcements, transverse reinforcements can be in the form of ties or in the form of helical hoops, based on this, column can be either "tied column" "spiral reinforced" or composite columns..

A column with the main reinforcement bars held together with separate tie bars (transverse) of smaller diameter spaced at regular intervals along the column height is called tied column. These ties are important for keeping the vertical reinforcement bars in place while casting and they also provide stability for the bars against buckling. Tied columns can be of different geometries; circular rectangular, or square. For circular and rectangular cross sections, minimum of four bars are used as main reinforcement (MacGregor, 2012).

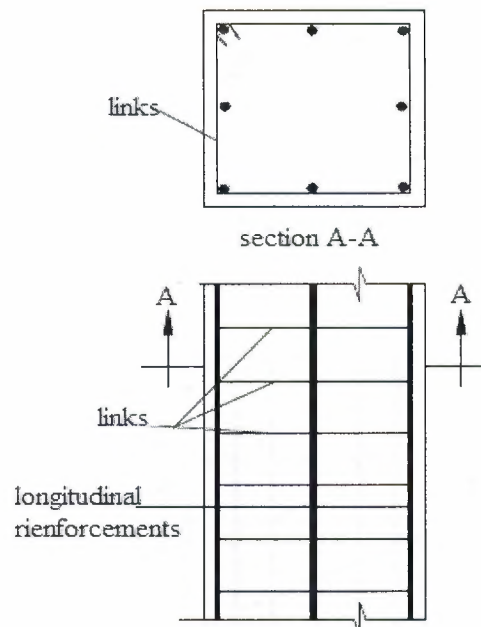

Figure 2.1: Tied Column (MacGregor, 2012)

Columns with the longitudinal bars arranged in a circular pattern held together by regularly spaced continuous spirals are referred to as spirally-reinforced. They are usually square or circular in shape requiring minimum number of six bars as main reinforcement (MacGregor, 2012).

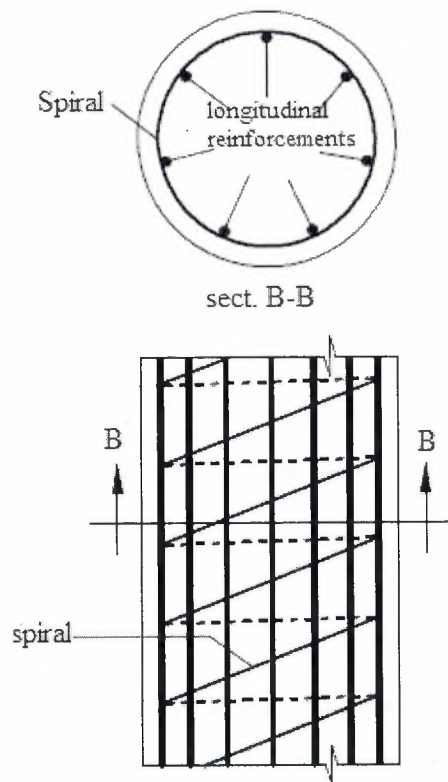

Figure 2.2: Spiral Column (MacGregor, 2012)

A composite column is built up of structural steel shapes filled by concrete. It may or may not have main reinforcement and various types of lateral reinforcements, shown in Figure (MacGregor, 2012).

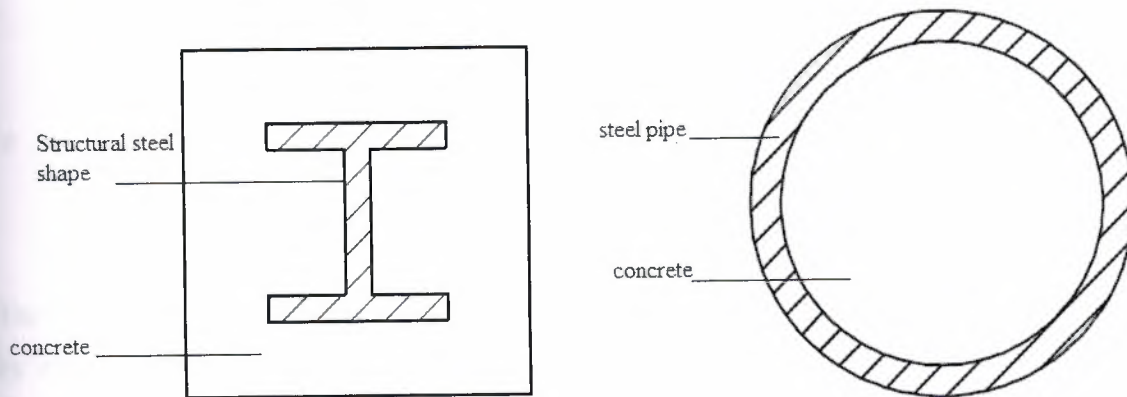

Figure 2.3: Composite Column (MacGregor, 2012)

2.3.1 Short Columns

Columns can be broadly classified as short and slender columns based on their slenderness ratio. The slenderness ratio of a concrete column is defined as the ratio of its effective length l_e to its least lateral dimensions. The effective length is the unsupported length multiplied by a factor usually specified in the design codes depending on the end conditions of the column. Each code has its own criteria for classifying column as either short or slender.

British Standard BS 8110-97 stipulates that a column with cross sectional dimensions b and D should be considered as short when both the slenderness ratios:

$$\frac{l_{ex}}{h} \text{ and } \frac{l_{ey}}{b} < 15 \text{ for a braced column} \quad (2.1)$$

$$\frac{l_{ex}}{h} \text{ and } \frac{l_{ey}}{b} < 10 \text{ for an unbraced column} \quad (2.2)$$

It shall otherwise be considered as a slender compression member.

Whereas ACI 318-11 provides that for a column to be classified as a short column it must satisfy the following;

$$\frac{kl_u}{r} \leq 34 - 12\left(\frac{M_1}{M_2}\right) \leq 40.0 \quad (2.3)$$

or

$$kl_u/r \leq 22 \text{ For non sway frames} \quad (2.4)$$

The strength of short columns is mostly governed by strength of the material as such it fails by either yielding or crushing depending on the type of material. Slender columns fail by buckling and the additional moments caused by deflection must be considered during design (Nilson, 1997).

Despite the fact that slender columns are becoming more common, probably due to the availability of high strength materials and improved dimensioning methods, it is still undisputable that most columns in ordinary practice can be considered as short columns. A column can either be braced or unbraced. Effective lateral bracing commonly provided by diagonal bracing, shear walls, elevator shafts or a combination of these prevents lateral movement of the two ends of a column.

“A number of years ago, an ACI -ASCE survey indicated that 90 percent of columns braced against sidesway and 40 percent of unbraced columns could be designed as short columns” (Nilson, 1997).

Short columns can further be divided into three categories;

- Columns resisting axial loads only
- Columns resisting axial load and uniaxial bending and
- Column resisting axial loads and biaxial bending

Consider the figure below:

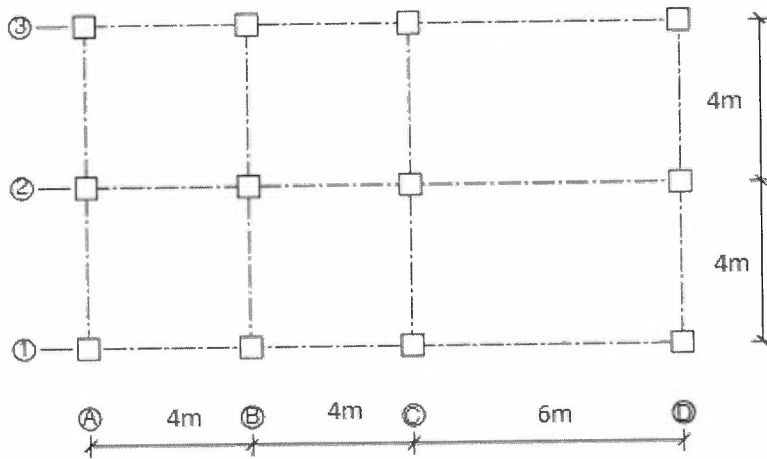

Figure 2.4: Column Types

- Column B2 supports beams of equal spans and symmetrical arrangement as such it will be subjected to only axial loading.
- Columns A2, B1, C1 D2, C3 and B3 are side columns; they are usually subjected to axial loading plus bending in one axis.
- Column C2 will also be supporting axial load and uniaxial bending because it supports beams of unequal spans.
- Columns A1, A3, D1 and D3 are corner columns and are biaxially loaded. There is bending due to the adjacent beams in both directions (Arya, 2009).

Due to the fact that columns are compressive members, failure of a column at a critical location can lead to the collapse of floors the above it and subsequently the collapse of the entire structure. So it plays an important role in buildings and its structural design must be adequate to ensure safety.



2.4 BS 8110-97

BS 8110-97 structural use of concrete is based on Limit-States Design principle.

2.4.1 Limit-States Design

Limit state design is seen as comprise between elastic method of design which involves keeping the stresses in the structure at working loads within the elastic range of the construction materials and plastic (load factor) design which takes into consideration the behavior of the structure after the yield point of the material is reached. BS 8110 combines these two methods in an appropriate way. The main objective of limit state method of design is to make sure that the structure does not fail to serve its purpose throughout the design life. A structure can be become unfit due excessive conditions of bending, cracking, and deflection. They are referred to as limit states.

These limit states are categorized into two; the Ultimate limit state which can cause the partial or complete failure of a structure and Serviceability limit state which affects the appearance of the structure. Ultimate limit takes into account the overall stability and estimating the load that will cause collapse structure; while serviceability limit state checks its behavior under normal working loads.

Limit-states design is a process which involves the identification of significant limit states (i.e., identification of all potential modes of failure), ascertaining the acceptable levels of safety against occurrence of each limit state using design codes which specify the load combinations and the load factors to be used, and structural design for the significant limit states.

2.4.2 Partial Factors of Safety for Materials

Materials factors of safety are considered to cater for the uncertainties of material strengths, inaccuracies of design equations used, variations in dimensions of concrete sections and placement of reinforcement, the significance of members in the structures approximations during analysis and so on.

BS8110 uses basic material partial factor of safety (γ_m)

$$\text{Design strength} = \frac{\text{Characteristic strength}}{\text{Material partial factor of safety } (\gamma_m)} \quad (2.5)$$

Table 2.1: Material Partial Factors of Safety (γ_m) At the Ultimate Limit State

Limit state	concrete	steel
flexure	1.5	1.15
Shear	1.25	1.15
Bond	1.4	

2.4.3 Partial Factors of Safety for Loads

BS8110-1997 also imposes partial factor of safety for loads; this is to cater for errors and inaccuracies that may occur due to a numbers of causes including assumptions when carrying out design, and errors in calculations, possible unforeseen load increases, and inaccuracies in construction.

$$\text{Design load (U)} = \text{characteristic load} * \text{partial load factor of safety } (\gamma_f) \quad (2.6)$$

2.4.4 Load Combinations

Table 2.2 gives the different load cases and the respective combination as stipulated by BS 8110-97.

Table 2.2: Load Combination and Partial Safety Factors for Loadings

Load cases	Load Combinations
D+L	$U = 1.4D + 1.6L$
D+W	$U = 1.4D + 1.4W$
D+L+W	$U = 1.2D + 1.2L + 1.2W$

L = Live load D = Dead load or related internal moments and forces W = Wind load

2.5 BS 8110-97 Code Requirements for Short Columns

Columns generally are discussed under section 3.8 of BS 8110-97. The provisions of this clause relate to columns whose greater overall cross-sectional dimension does not exceed four times its smaller dimension. The provisions relate primarily to rectangular cross-sections; however the principles involved may be applied to other shapes (such as circular sections) where appropriate. Clause 3.8.1.3 stipulates that a column may be considered as short when both the ratios l_{ex}/h and l_{ey}/b are less than 15 (braced) and 10 (unbraced). It should otherwise be considered as slender.

Some of the most important provisions of this code as they relate to short columns are outlined.

2.5.1 Braced and Unbraced Columns

Clause 3.8.1.5 of BS 8110 states column may be considered braced in a given plane if lateral stability to the structure as a whole is provided by wall or bracing or buttressing designed to resist all lateral forces in that plane. It should otherwise be considered as unbraced. If lateral loads in a column are resisted by its own sway action, such column may be considered to be unbraced. A column can be braced in one or both vertical and horizontal direction. In Fig 2.5, the columns are braced in the in both directions. (Arya, 2009).

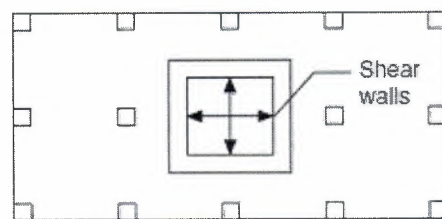

Figure 2.5: Braced Columns (Arya, 2009)

2.5.2 Effective Height of a Column

The effective height of a column is the clear height between the lateral restraints (l_o) multiplied by a coefficient (β) which is a function of the end fixity of the column.

$$l_e = \beta l_o$$

Values of β are given in Table 3.19 and Table 3.20 of BS 8110 for braced and unbraced columns respectively as a function of the end conditions of the column.

Table 2.3: Values of β for Short Braced Columns (BS 8110, 1997)

End condition at top	End condition at bottom		
	1	2	3
1	0.75	0.80	0.90
2	0.80	0.85	0.95
3	0.90	0.95	1.00

Table 2.4: Values of β for Short Unbraced Columns (BS 8110, 1997)

End condition at top	End condition at bottom		
	1	2	3
1	1.2	1.3	1.6
2	1.3	1.5	1.8
3	1.6	1.8	—
4	2.2	—	—

2.5.3 Minimum Eccentricity

Section 3.8.2.4 of BS 8110 states that at no section in a column should the design moment be taken as less than that produced by considering the design ultimate axial load as acting at a minimum eccentricity, e_{min} , equal to 0.05 times the overall dimension of the column in the plane of bending considered but not more than 20 mm. Where biaxial bending is considered, it is only necessary to ensure that the eccentricity exceeds the minimum about one axis at a time.

2.5.4 Minimum Number of Longitudinal Bars in Columns

Clause 3.12.5 of BS 8110-97 recommends a minimum of one bar in each corner i.e. four bars in a rectangular column and six bars in a circular column and three bars for a triangular column. All the bars must be at least 12 mm in diameter.

2.5.5 Spacing of Reinforcement

BS 8110 specifies that the minimum space between adjacent bars should be at least the same as the diameter of bars or the maximum size of the coarse aggregate + 5 mm. No limitation for the maximum bar spacing was specified, but for professional reasons it is usually limited to 250 mm.

2.5.6 Percentage of Longitudinal Reinforcement

Clause 3.12.5 of BS 8110-97 stipulates the minimum and maximum amount of longitudinal reinforcement calculated as a percentage of the gross area A_g of the column. The lower limit is to cater for errors that may arise in the process of analysis and also to reduce the effect of creep and shrinkage in column under loading. The use of high reinforcement ratios is not only uneconomical; it would involve practical difficulties in the placing of concrete owing to the congestion of the reinforcements. This increases the chances of honeycomb occurring in the concrete and subsequently a significant decrease in the load-carrying capacity of the column.

Table 2.5: Minimum and Maximum Column Longitudinal Steel Ratio

Code	Min. Steel Ratio	Max. Steel Ratio
BS8110	0.004 A_g	0.06 A_g

2.5.7 Size and Spacing of Links

Links are effective in restraining the longitudinal bars from buckling out through the surface of the column, holding the reinforcement cage together during the construction process, confining the concrete core and when columns are subjected to horizontal forces, they serve as shear reinforcement (McCormac and Nelson, 2014).

Clause 3.12.7, BS 8110 recommends that the diameter of the links is required to be at least one-quarter of the largest longitudinal bar size or a minimum of 8 mm. It also recommends that, the maximum tie spacing should be either 12 times of the smallest min bar or the smaller of the cross sectional dimensions of column.

Tie should be more closely spaced in order to provide adequate resistance to the shearing forces in the column.

2.5.8 Arrangement of Links

BS 8110-97 requires that links should be so arranged that every corner and alternate bar in an outer layer of reinforcement is supported by a link passing around the bar and having an included angle of not more than 135° . All other bars should be within 150 mm of a restrained bar.

2.5.9 Concrete Cover to Reinforcement

Section 3.3.1.2 of BS 8110 recommends that the nominal cover to all steel should be such that the resulting cover to a main bar should not be less than the size of the main bar or, where bars are in pairs or bundles, the size of a single bar of cross-sectional area equal to the sum of their cross-sectional areas. At the same time the nominal cover to any links should be preserved.

2.5.10 Nominal Maximum Size of Aggregate

Section 3.3.1.2 of BS 8110 recommends that nominal covers should be not less than the nominal maximum size of the aggregate. The nominal maximum size of coarse aggregate should not normally be greater than one-quarter of the minimum thickness of the concrete section or element. For most work, 20 mm aggregate is suitable. Larger sizes should be permitted where there are no restrictions to the flow of concrete into sections. In thin sections or elements with closely spaced reinforcement, consideration should be given to the use of 14 mm or 10 mm nominal maximum size.

2.6 Short Column Design According to BS 8110-97

2.6.1 Short Axially Loaded Column

For a column with cross-sectional area of concrete A_c and that of longitudinal or steel reinforcement A_{sc} ; from stress-strain analysis, the design stress for concrete in compression is $0.67f_{cu}/1.5$ and that of steel is $f_y/1.15$.

$$\text{Concrete design stress} = \frac{0.67f_{cu}}{1.5} \quad (2.7)$$

$$\text{Reinforcement design stress} = \frac{f_y}{1.15} \quad (2.8)$$

As both the concrete and reinforcement contribute in carrying the load; the sum of the loads supported by the reinforcement F_s and concrete F_c gives the maximum load N that the column can carry. i.e.

$$N = F_c + F_s$$

but,

$$F_c = \text{stress} \times \text{area} = 0.45f_{cu}A_c$$

and

$$F_s = \text{stress} \times \text{area} = 0.87f_yA_{sc}$$

therefore,

$$N = 0.45f_{cu}A_c + 0.87f_yA_{sc} \quad (2.9)$$

Equation 2.9 assumes that there is no eccentricity, but in practice, such condition does not exist. Hence to take into account small eccentricity the design stresses are reduced by about 10 per cent, and thus the following equation:

$$N = 0.4f_{cu}A_c + 0.75A_{sc}f_y \quad (2.10)$$

Equation 2.10 is used for the design of short-braced axially loaded columns.

The design ultimate axial force is given by the equation;

For a rectangular cross section;

$$N = 0.4f_{cu}bh + (0.75f_y - 0.4f_{cu})A_{sc} \quad (2.11)$$

Area of steel A_{sc} ;

$$A_{sc} = \frac{N - 0.4f_{cu}bh}{0.75f_y - 0.4f_{cu}} \quad (2.12)$$

For short braced columns that support approximately symmetrical arrangement of beams where the beams are designed for uniformly distributed imposed loads and the beam spans do not differ by more than 15 % of the longer; the column is subject to an axial load and 'small' moment the design ultimate axial load may be calculated by decreasing the design stresses in equation by around 10 per cent resulting in the following equation; (Arya, 2009)

$$N = 0.35f_{cu}A_c + 0.7A_{sc}f_y \quad (2.13)$$

2.6.2 Short Uniaxially Loaded Columns

The longitudinal area of steel short column subjected to ultimate axial load and bending in one direction (about major or minor axis) according to BS 8110-97 is usually calculated using column design charts provided in part 3 of BS 8110. The charts are for columns of rectangular section, however, they can be used to estimate the amount of steel required for column of circular cross section but the area of steel obtained is usually 10 per cent greater than required. (Arya, 2009)

Each chart is unique for a particular for a selected characteristic strength of concrete, f_{cu} , characteristic strength of reinforcement, f_y and d/h ratio.

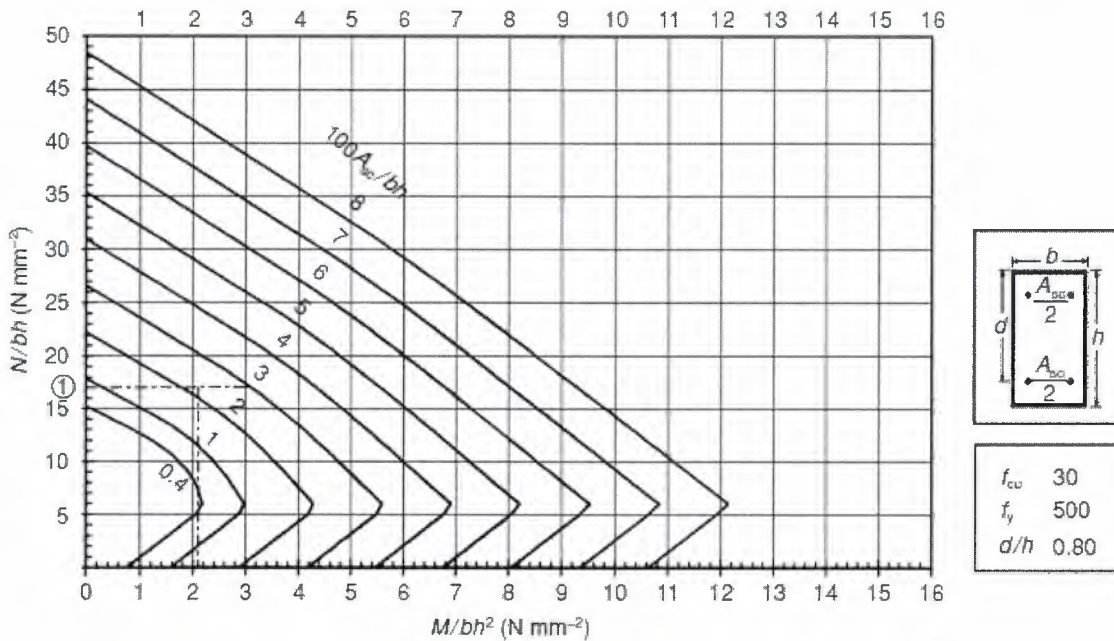

Figure 2.6: Column Design Chart (Arya, 2009)

For a column subjected to axial load N , and moment about an axis M , the design procedure simply involves plotting the values of N/bh and M/bh^2 on the chart of its corresponding f_y , f_{cu} and d/h ratio. The area of reinforcement required is read off as a percentage of the gross-sectional area of concrete ($100A_{sc}/bh$).

2.6.3 Short Biaxially Loaded Columns

For column subjected to axial load N and bending in both directions M_{xx} and M_{yy} , the standard recommends to be reduced to uniaxial loaded column by increasing the applied moment in one direction and designing the column using chart. The procedure is as follows;

- i. Determine the axial load N
- ii. Determine the two moments M_{xx} and M_{yy}
- iii. Determine $h' = h - d'$ and $b' = b - d'$

d' is the distance from the concrete face to centre of reinforcement.

iv. The increased moment is calculated as either;

When

$$M_{xx}/h' \geq M_{yy}/b'$$

$$M'_{xx} = M_{xx} + \beta \frac{h'}{b'} M_{yy} \quad (2.14)$$

Otherwise

$$M'_{yy} = M_{yy} + \beta \frac{h'}{b'} M_{xx} \quad (2.15)$$

$$\beta = 1.0 - 1.1644\phi$$

and

$$\phi = N/f_{cu}bh$$

v. The values of N/bh and the increased M/bh^2 are calculated and A_{sc} is determined from the relevant chart.

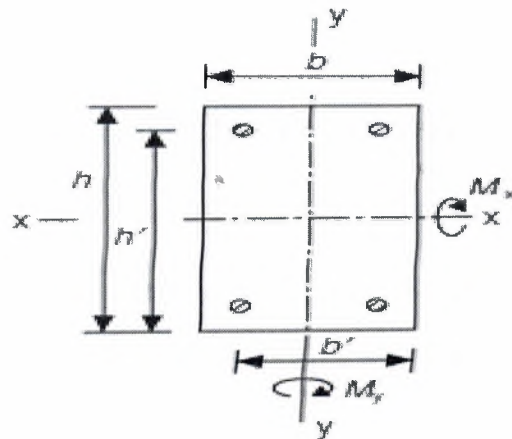

Figure 2.7: Biaxially Loaded Column (BS 8110, 1997)

2.7 ACI 318M-11

2.7.1 Strength Design Method

Reinforced concrete design to ACI 318M-11 is based on required strengths computed from a combination of factored loads and design strengths (ϕR_n) where ϕ is known as the strength reduction factor and R_n is the nominal resistance. The strength provided must be greater than the required strength to carry these factored loads and thus the process is referred to as *strength design*. ACI strength design is a limit-states design method; members are designed to resist the ultimate limit states, and then checked against the serviceability limit states. (MacGregor, 2012)

2.7.2 Load Combinations

The 2011 ACI Code Sections 9.2.1 presents load factors and load combinations which are to be used with the strength-reduction factors in Code Sections 9.3.1 through 9.3.5.

Table 2.6: Load Combinations

Load cases	Load combinations
D	$U = 1.4D$
D+L+Lr or S or R	$U = 1.2D + 1.6L + 0.5(Lr \text{ or } S \text{ or } R)$
D+ Lr or S or R +L or W	$U = 1.2D + 1.6(Lr \text{ or } S \text{ or } R) + (1.0L \text{ or } 0.5W)$
D+L+W+ Lr or S or R	$U = 1.2D + 1.0W + 1.0L + 0.5(Lr \text{ or } S \text{ or } R)$
D+L+E+S	$U = 1.2D + 1.0E + 1.0L + 0.2S$
D+W	$U = 0.9D + 1.0W$
D+E	$U = 0.9D + 1.0E$

2.7.3 Strength Reduction Factors

The ACI strength reduction factors for members under different loading conditions are given in Table 2.8.

Table 2.8: ACI strength reduction factors (ACI 318, 2011)

ACI 318M-11	Φ Factors
Flexure	0.90
Axial tension	0.90
Shear and torsion	0.75
Compression members spirally reinforced (circular column)	0.75
Compression members tied reinforced (tied column)	0.65
Bearing on concrete	0.65
Strut-and-tie model	0.75

2.8 ACI 318M-11 Code Requirements for Short Columns

2.8.1 Percentage of Longitudinal Reinforcement

Section ACI Code 10.9.1 stipulates the minimum or maximum amount of longitudinal reinforcements expressed as a percentage of the gross area of the column.

Table 2.9: Minimum and Maximum Column Longitudinal Steel Ratio ($\rho = A_{st}/A_g$)

Code	Min. Steel Ratio	Max. Steel Ratio
ACI 318M-11	0.01 A_g	0.08 A_g

2.8.2 Minimum Number of Longitudinal Bars in Columns

Section 10.9.2 of ACI 318 Codes recommends a minimum of four bars in a rectangular column (one bar in each corner), six bars in a circular column and three bars for a triangular column.

2.8.3 Clear Distance between Reinforcing Bars

ACI Code 7.6.3 and 7.6.4 specify that the clear distance between bars should not be less than the larger of 1.50 times bar diameter or 4 cm for tied or spirally reinforced columns. This ensures free flow of concrete between the reinforcing bars. This limitation also applies to the clear distance between adjacent lap splices and lap spliced bars since the maximum number of bars is at the splices.

2.8.4 Lateral Ties

Ties are effective in restraining the longitudinal bars from buckling out through the surface of the column, holding the reinforcement cage together during the construction process, confining the concrete core and when columns are subjected to horizontal forces, they serve as shear reinforcement (McCormac and Nelson, 2014).

Section 7.10.5.1 of ACI318 Codes recommends that the diameter of lateral ties should not be less than;

- 10mm for longitudinal bars of 32mm diameter or smaller and
- 13mm for larger longitudinal bar.

Welded wire reinforcement of equivalent area is also permitted.

2.8.5 Vertical Spacing

Section 7.10.5.1 of ACI318 Codes recommends that, the center-to-center spacing of ties shall not be more than

- 16 times the diameter of the longitudinal bars,
- 48 times the diameter of the ties, or
- The least lateral dimension of the column.

2.8.6 Spirals

The ACI code (7.10.4) states that spirals may not have diameters less than 10mm and that the clear spacing between them may not be less than 25mm. or greater than 75mm. Should splices be necessary in spirals, they are to be provided by welding or by lapping deformed uncoated spiral bars or wires by the larger of 48 times diameters or 300mm.

2.9 Short Column Design According ACI

2.9.1 Short Axially Loaded Column

For a column subjected to axial load, concrete and reinforcing steel will have the same amount of shortening. Concrete reaches its maximum strength at $0.85f'_c$ first. Then, concrete continues to yield until steel reaches its yield strength, f_y , when the column fails. The strength contributed by concrete is $0.85f'_c(A_g - A_{st})$, The strength provided by reinforcing steel is $A_{st}f_y$

Where; f'_c is compressive strength of concrete, A_g is gross area of column, A_{st} is areas of reinforcing steel, and f_y is the yield strength of steel

Therefore, according to ACI Code 10.3.5, the useful *design strength* of an axially loaded column is to be found based on Eq 2.16.

$$P_n = 0.85f'_c(A_g - A_{st}) + A_{st}f_y \quad (2.16)$$

To account for the effect of accidental moments, ACI Code specifies that the maximum load on a column must not exceed 0.85 times the load from Eq. 2.16 for spiral columns and 0.8 times Eq. 2.16 for tied columns. Thus;

For spirally reinforced columns

$$\phi P_n \max = 0.85\phi[0.85f'_c(A_g - A_{st}) + A_{st}f_y] \quad (2.17)$$

With $\phi = 0.70$

For tied columns

$$\phi P_n \max = 0.80\phi[0.85f'_c(A_g - A_{st}) + A_{st}f_y] \quad (2.18)$$

With $\phi = 0.65$

For a given axial load P_n and a gross sectional area A_g , the area of steel can be computed by rearranging the above equations.

2.9.2 Short Uniaxially Loaded Column

The load capacity of a reinforced concrete column subjected to moment and axial loading can be estimated from an interaction diagram; such a diagram shows the relationship between the axial load capacity and moment capacity of a reinforced concrete column prior to yielding of the longitudinal reinforcement. In the case of uniaxial and biaxial columns, ACI318 Design manuals provide interaction diagrams (P-M charts) of concrete column with strength reduction factor for the various steel and concrete grades that are used to determine steel ratio which will satisfy both axial load and moments.

The vertical axis is $\phi P_n / A_g$ and the horizontal axis is $\phi M_n / A_g h$, where h is the dimension of column in the direction of moment. Curves are drawn for different values of $\rho_g = A_{st} / A_g$. They are mostly used together with the series of radial lines denoting different eccentricity ratios e / h . The chart is arranged based on the ratio, γ which is the ratio of the distance between centres of longitudinal reinforcements to h .

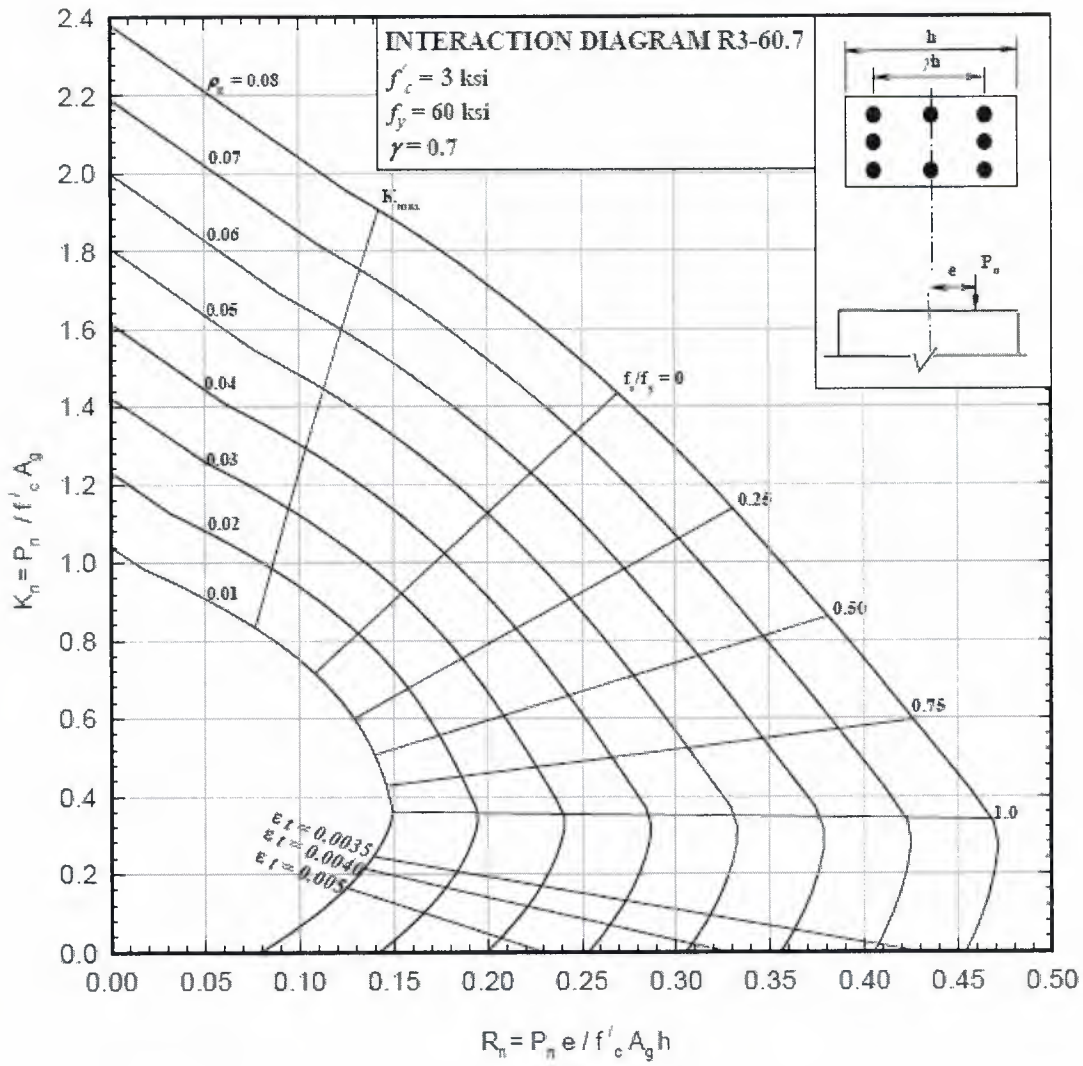

Figure 2.8: Column Interaction Diagram (Reynolds et al., 2008)

Two conditions must be satisfied for the design of uniaxially loaded short columns, they are;

- 1. Design strength: $\phi P_n \geq P_u$ and $\phi M_n \geq M_u$
- 2. Minimum eccentricity, $e = M_u/P_u \geq .1.0$

The design procedure is as follows:

- Factored axial load, P_u and factored moment, M_u are calculated
- A trial column with b and column depth, h in the direction of moment is selected.
- Gross area, A_g and ratio, $\gamma = \text{distance between rebar}/h$ are calculated.
- The ratios, P_u/A_g and $M_u/A_g h$ are the calculated
- The reinforcement ratio ρ is evaluated from the relevant design chart based on concrete strength, f'_c , steel yield strength, f_y , and the ratio, γ .
- The area of column reinforcement, A_s is calculated and the appropriate rebar number and size are selected.
- Column ties are designed.

2.9.3 Short Biaxially Loaded Column

A number of approximate methods are used for the design of short columns subjected to moments about two axes, these include among others are the reciprocal loads method among others.

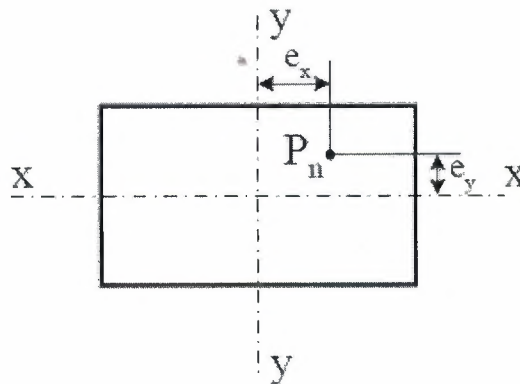
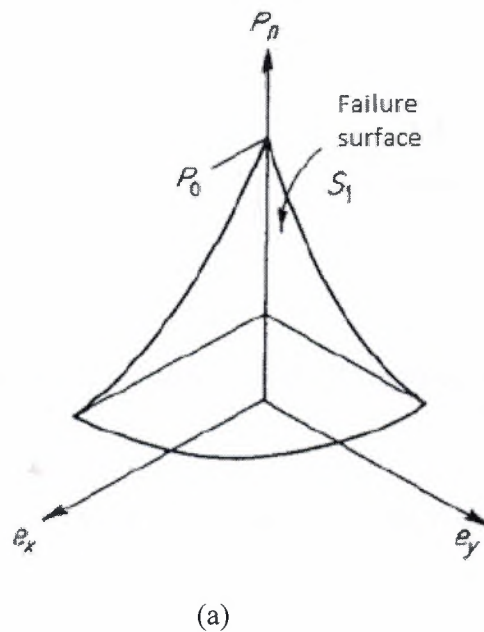
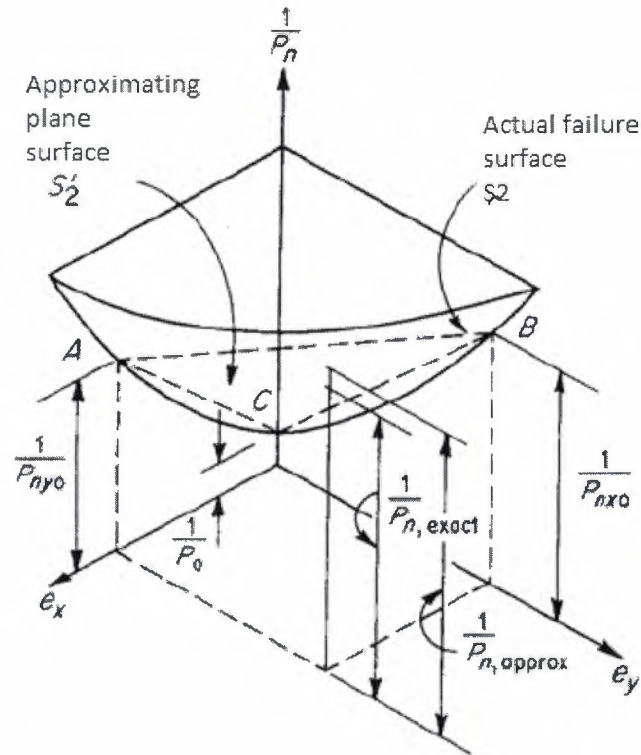

Figure 2.9: Notations used for Column Subjected to Biaxial Bending (Reynolds et al, 2008)

2.9.3.1 The Reciprocal Load Method

The Reciprocal Load Method is the method suggested by the ACI code and it uses the concept of a failure surface to reflect the interaction of three variables, the nominal axial load P_n and the nominal eccentricities $e_x = M_{ny}/P_n$ and $e_y = M_{nx}/P_n$ which in combination will cause failure strain at the extreme compression fiber. The failure surface reflects the strength of short compression members subject to biaxial bending and compression as shown in fig 2.10





(b)

Figure 2.10 (a) and (b): Interaction Surfaces for the Reciprocal Method (Nilson, 1997)

The surface S_1 in fig a can be represented by an equivalent failure interaction surface S_2 , shown here in fig b where e_y and e_x are plotted against $1/P_n$. Thus $e_x = e_y = 0$ is the inverse of the capacity of the column when it was only axially loaded, P_0 , and this is denoted as point C. When $e_y = 0$, for any value of e_x , there is a load P_{ny0} that would cause failure. Therefore the reciprocal of these loads is plotted as point A. Likewise, when $e_x = 0$ for any value of e_y , there is a certain load P_{nx0} which will cause failure, the reciprocal of which is at point B. Hence, for known eccentricities values of P_{ny0} , P_{nx0} can be determined, using design charts for uniaxial bending (Nilson, 1997).

The oblique planes S_2' specified by points A, B, and C is used as an approximation of actual failure surfaces S_2 . It is worthwhile to mention that for any given combination of e_x and e_y

on the failure surface S2, there exists corresponding planes S2'. Therefore the approximation of the true failure surfaces S2 requires an infinite number of planes which are determined by particular pairs of values of e_x and e_y (Nilson, 1997).

Bresler's reciprocal load equation is derived from geometry of this approximating plane. It can be shown that

$$\frac{1}{P_n} = \frac{1}{P_{nx0}} + \frac{1}{P_{ny0}} - \frac{1}{P_0}$$

Where;

P_n : Approximate value of ultimate load in biaxial bending with eccentricities e_x and e_y

P_{ny0} : ultimate load when only eccentricity e_x is present ($e_y = 0$)

P_{nx0} : ultimate load when only eccentricity e_y is present ($e_x = 0$)

P_0 : ultimate load for concentrically loaded column ($e = 0$)

Taking into account the strength reduction factor, the equation can be re-written as;

$$\frac{1}{\phi P_n} = \frac{1}{\phi P_{nx0}} + \frac{1}{\phi P_{ny0}} - \frac{1}{\phi P_0}$$

2.10 General Climate of Nigeria

Nigeria is a country in West Africa which lies within the tropical zone with a tropical humid climate dominated by West African monsoon system. Two seasons are experienced in Nigeria: a wet season from the months of April to October and a dry season from November to March. During the wet season, moisture-laden south westerly winds from the Atlantic brings about cloudy and rainy weather, while in the dry season, dry north easterly wind from the Sahara brings about dusty and fair weather.

There are, however, wide variations in climate in different regions of the country with topographic relief being a major factor. The average annual temperatures throughout Nigeria are over 20°C. Generally, temperature is lower in the wet season than in the dry season, and varies a little from the coast to inland regions.

The highest rainfall is recorded in the month of June in southern Nigeria; the wettest area is the east coast, receiving up to 4000 mm of rainfall per annum. The regions along the coast in western Nigeria receive about 1800 mm of rainfall per annum, which declines to about 500-1000 mm in the central and northern Nigeria.

Nigeria is not located within the major seismic zones of the world and hence no major seismic hazard has been recorded over the years.

2.10.1 Climatic Conditions in Kano Nigeria

The Kano region located at 12° 0' 0" N, 8° 31' 0" E at an altitude of 481m above sea level in northern Nigeria enjoys savanna vegetation with a hot semi-arid climate. An average about 690 mm of precipitation per year is recorded in Kano, most of which falls in the months of June to September. It is typically very hot throughout the year, though the city is noticeably cooler from the months of December to February. The annual average high temperature is about 33°C. Nighttime temperatures are relatively cool in the months of December, January

and February, with an average low temperature ranging between 11° to 14°C. The average wind speed is about 10m/s.

CHAPTER 3

METHODOLOGY

3.1 Introduction

In order to achieve the aim of this study, a multi story reinforced concrete building was modeled and analysed using SAP 2000 structural analysis software. Two separate models were developed in accordance with the provisions of ACI 318M-11 AND BS 8110-97. The forces on the columns obtained from the result of the analysis were used to design the column using another program Prokon. The design output was compared. Table 3.1 gives the general information about the building.

Table 3.1: General Building Information

GENERAL INFORMATION	
Site	Kano, Nigeria.
Intended use of the structure	Hospital
Design Stresses	Concrete f_{ck} --- 25Mpa, Steel f_y --460Mpa
Soil condition	Firm gravely lateritic clay Allowable soil bearing capacity --- 150kN/m ²
Fire resistance	2 hrs for elements
Exposure condition	Moderate
General Loading condition	Slab (LL) , Roof=1.5kN/m ² Room=3.5kN/m ² Corridor &stair =5.0 kN/m ² Total live on roofing---2.794 kN/m ²
Total area of building	4132m ²

The building is located in Kano, Nigeria at an altitude of 268m. The building is type B and the soil type is Z3. The structure is a seven-story reinforced concrete hospital building of approximately 3.4 m floor height measured from the surface of the slab to suspended beam soffits. A roof and utility access panel was positioned above the 7th storey of the building. . A roof and utility access panel was positioned above the 7th storey of the building.

3.2 Geometry of the Building

The framing plan of the seven-story reinforced concrete building was provided and can be seen in appendix 2. As shown in the framing plan, the building is nine bays by five bays. The first and last three bays along the six-bay side are 6.4m center-to-center while three inner bays are 3.4m center-to-center. The bays along the three-bay side are 3.8m center-to-center. The framing plan also denotes two-way slabs with beams that run along the six-bay columns. The ground floor has an area of 570.6 m², the subsequent floors each have an area of 593.40 m² area.

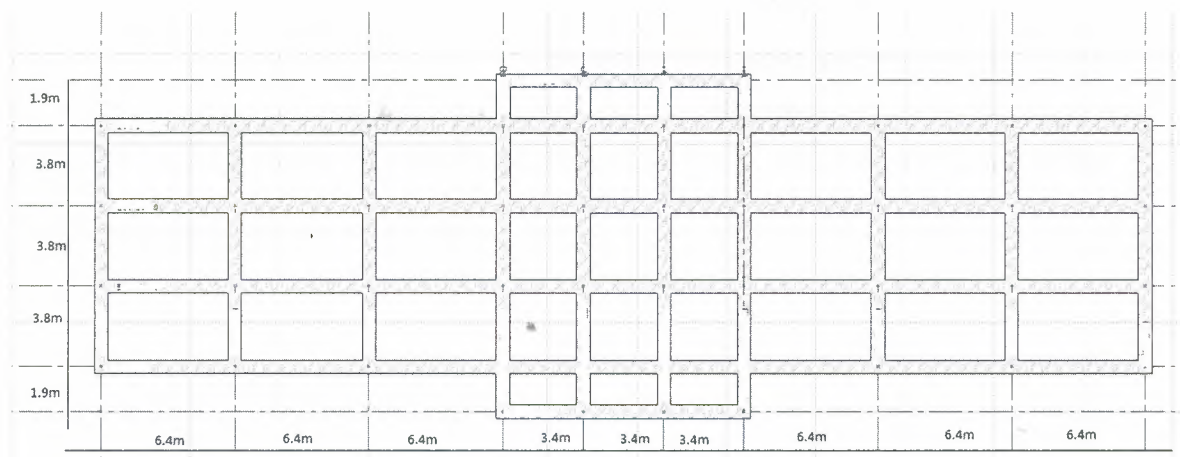

Figure 3.1: Floor plan

The height of all the stories of the building is 3.4m. An elevation view of the hospital building is shown in Figure 3.2.

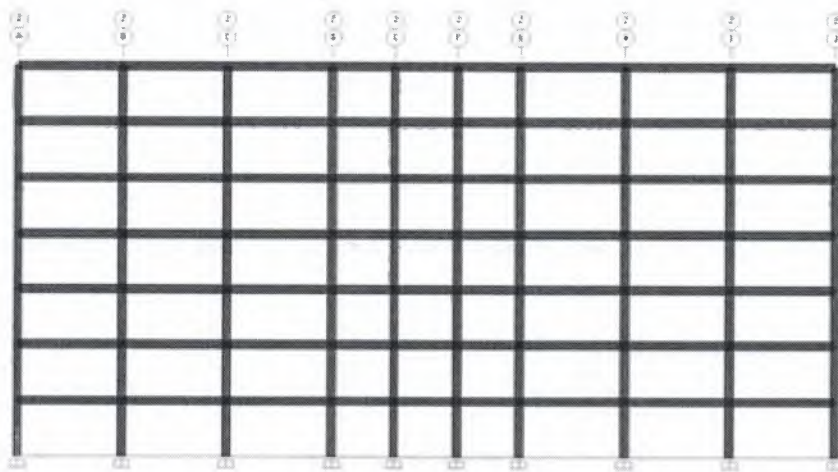

Figure 3.2: Front Elevation

It can be seen from the plan that the building can be divided into two parts which are a replica of each other along the horizontal axis. The members' dimensions, positions and loadings are all the same, it is therefore convenient after analysing the whole structure to design the columns on one side of the building, these results will also be valid for columns on the other side.

3.3 Assigning Column ID

Owing to the symmetrical geometry of the building as can be seen from the floor plans, some columns have the same loading conditions; these columns were categorized and numbered from C01 to C10 in a convenient way from left to right and from the lower to the upper part of the plan. To differentiate the columns located on specific stories, the columns are identified as 105, 205, 305, 405, 505, 605 and 705 with the first digit indicating the

storey number while the last two digits indicate column number. Therefore column with ID 605 is a column numbered 05 in sixth floor.

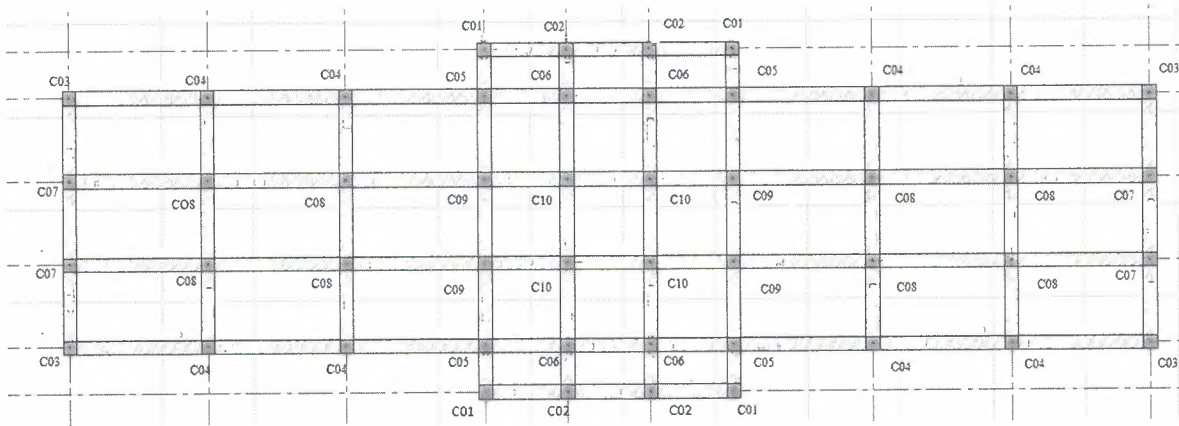

Figure 3.3 Column ID

3.4 Preliminary Design

3.4.1 Member Sizing

For the purpose of analysis, preliminary sizes of the structural elements (beams, slabs and columns). The sizes of slabs and beams were first determined and from the axial loads transferred by the beams and slab due to live and dead loads, the column sizes are estimated. The member sizes were determined as follows;

Slab Thickness: The slabs are with beams spanning between the supports on all sides, they are two way spanning slabs with the ratio of the longer span to that of the shorter one being less than two.

According to ACI 318M-11, the thickness h was determined in accordance with section 9.5 in ACI 318M-11 which specifies the minimum thickness of members to control deflection using the equation;

$$h = \frac{l_n(0.8 + \frac{f_y}{1400})}{36 + 9\beta} \quad (3.1)$$

l_n is clear span length in longer direction measured face-to-face of beams. Term

β is ratio of clear spans in long direction to short direction of slab.

The thickness of each of slab was calculated and from the result obtained the critical value was 150mm.

According to BS 8110-97, =

$$d_{\min} = \frac{\text{span}}{\text{basic ratio} \times \text{modification factor}} \quad (3.2)$$

A value of 1.4 was assumed for the modification factor. The minimum slab thickness was calculated as 150mm. Slab of thickness 150mm was used throughout the entire building for ease of construction and economical purposes.

Beam Thickness: The beams are of rectangular cross-section. They are simply supported. The longest span is 6.4m and it was considered during the sizing.

According ACI, the depth of the beam was calculated from table 9.5a of ACI 318M-11 as

$$\text{Depth} = \frac{L}{16} \quad (3.3)$$

For a beam of length 6.4m, the minimum depth for deflection control was found to 400mm.

According to BS 8810, section 3.4.6 specifies that to control deflection in a beam, the ratio of its span to its effective depth should not be greater than an appropriate ratio. For a simply supported beam having a rectangular cross-section,

$$\frac{\text{Span}}{\text{Effective Depth}} \leq 20 \quad (3.4)$$

Thus for a beam of length 6.4m, the minimum depth was calculated as 320mm. The most economical beam sections are usually obtained for shorter beams (up to 7m in length), when the ratio of d to b is in the range of 1.5 to 2 (McCormac and Nelson, 2014). Based on these a beam dimension of 500mmx300mm was selected and used throughout the building.

3.4.2 Gravity Loads

The loading on these structural elements were calculated as per the provisions of ASCE7-10 and BS 6399. Imposed loads (dead and live load) and wind loads were considered for the purpose of this study. As the building is sited in a non-seismic zone, earthquake and snow loads were not considered. However the values of the imposed loads considered were made the same for both codes to enable a level ground for comparison.

Dead loads are the self weight of the structural members. It was calculated with the weight of materials and volumes of the members. The unit weight of concrete was taken as 24 kN/m³. Beam dead load was calculated by multiplying cross sectional area of the beams with the unit weigh of concrete 24kN/m³. Dead load on the slabs was calculated by multiply slab thickness with unit weigh of concrete kN/m²; the uniformly distributed loads will be applied area forces in SAP 2000. Wall of unit weight 3.47 kN/m² with rendering was used. The unit weight was multiplied by the height and the weight of the walls on slabs and beams were calculated per running meter. Additional dead loads to cater for floor finishes, partitions, equipments and furniture were also considered.

Taking into account the minimum live loads stipulated in both BS 6399 and ASCE-07 10, the live loads on the slabs were taken 5.0kN/m² for corridors and stairs, 3.5kN/m² for other rooms in the hospital. Live load on the roof was taken to be 2.79 kN/m².

3.4.3 Wind Load

Average wind speed in Kano is about 10m/s. The design wind pressures per unit area of the building were calculated. The pressure is then converted in to load and applied according to the models.

Wind Pressure according To ASCE-7 10: The calculations were according to ASCE-7 10 code for minimum design load on structures. The design wind pressures were calculated using the equations;

$$p = qGC_p - qi(GC_{pi}) \text{ (N/m}^2\text{)} \quad (3.5)$$

Where; q is Velocity Pressure = $0.613 K_z K_{zt} K_d V^2$ (N/m²) V in m/s, and either $q = q_z$, the velocity pressure calculated at height z above the ground level on the windward wall, or $q = q_h$, the pressure on the roof, leeward walls, and sidewalls, calculated at the mean roof height h , q_i is the suction on interior of the walls and roof of the building, also calculated at the mean roof height. K_{zt} = topographic factor, V = basic wind speed, K_d = wind directionality factor, K_z = velocity pressure exposure coefficient, C_p = pressure coefficient, G = Gust Effect Factor.

Wind Pressure according To Bs6399, Part 2, 1997: The British Standard Code of Practice, BS6399, Part 2, 1997 method for estimating wind loads on buildings was adopted. The design wind pressures at different height of the building were calculated using the formula;

$$W_k = 0.613 v_s^2 \text{ (N/m}^2\text{)} \quad (3.6)$$

$$V_s = V S_1 S_2 S_3 \text{ (m/s)} \quad (3.7)$$

Where; V = basic wind speed, V_s = design wind speed, S_1 = multiplying factor related to topography taken as 1.0, S_2 = multiplying factor related to the height of the building above the ground obtained from Table 3 BS 6399 Part 2, 1997. S_3 = statistical factor related to the life of the structure taken 1.0. W_k = the wind load in N/m².

The calculated wind pressures were found to be insignificant with the highest values being less than 0.1 k N/m^2 and were not considered in the analysis of the structure.

3.5 Sizing of Columns

The first step in the process of determining the column size was the calculation of the tributary area of the most heavily loaded column, which according to this building plan was an interior column, (i.e. C5), the tributary area was calculated as 24.32m^2 . The dead and live loads of the roof and four floors were multiplied by this tributary area to determine the factored load that is being transmitted to the ground story column. The area of the concrete needed to sustain the calculated force was then calculated based the strength of the concrete and the steel according to the two codes. Appropriate overall strength reduction factors were included to account for eccentric loading of the column and also to provide a further factor of safety. 2% of the area of the column was assumed to be steel.

According to ACI code: The gross area of the column A_g was determined to be $121,4999.9 \text{ mm}^2$ using the equation;

$$\phi P_n = \phi [0.80 [0.85 f_c (A_g - A_{st}) + f_y A_{st}]] \quad (3.8)$$

Where; ϕ = strength reduction factor, taken as 0.65 for a rectangular cross-section, P_n = calculated force, A_g = gross area of the column, A_{st} = area of steel, taken as $0.002A_g$, f_y = tensile strength of steel, f_c = compressive strength of concrete.

According to BS code: The gross area of the column A_g was determined to be 119, 030.30 mm^2 using the equation;

$$N = 0.4f_{cu}A_c + 0.75A_{sc}f_y \quad (3.9)$$

Where; N = calculated load, f_{cu} = compressive strength of concrete, A_c = area of concrete,

A_{sc} = area of steel, f_y = tensile strength of concrete.

Considering the gross area of the column calculated according to both code, a column of dimensions 400mm x 300mm was to be used. However a column of dimensions 500mm x 300 mm was chosen to cater for any errors that may arise from the estimation of the loads coming to the columns.

3.6 Structural Analysis

The forces on the columns of this building were obtained from structural analysis carried out using the SAP 2000 program. SAP 2000 is general purpose software for the finite element modeling, dynamic, static and non-linear analysis and design of structures according to different design codes. It gives detailed analysis result (member forces) for individual structural elements. These functionalities and many more have earned SAP 2000 recognition as one of the best structural analysis programs. The SAP 2000 user interface allows for modeling, analyzing and displaying the geometry of the structure, properties and analysis results. This analysis procedure involves;

3.6.1 Modeling of the Structure

The dimensions of the structural members and other results obtained from the preliminary design were used in SAP 2000 program to create a model for each of the codes. The first step in creating the model was choosing the units, then using the 3D FRAMES feature in the program, the number of stories, number of bays in both x and y directions then grid spacing were specified. Joint constraints were added to ensure rigidity of the structure.

3.6.2 Defining Material and Member Section Properties

The next step involves defining material and member sections. The material was defined as concrete grade 25 (C25) for all members. For the member sections, the columns and beams were defined as rectangular sections 500x300 mm and 500x300mm respectively. The slabs were defined as area sections (thin shell sections) with a thickness of 150 mm. The material and member section properties were then assigned accordingly. Based on these input the geometry of the structure was set up as shown in Figure 3.4.

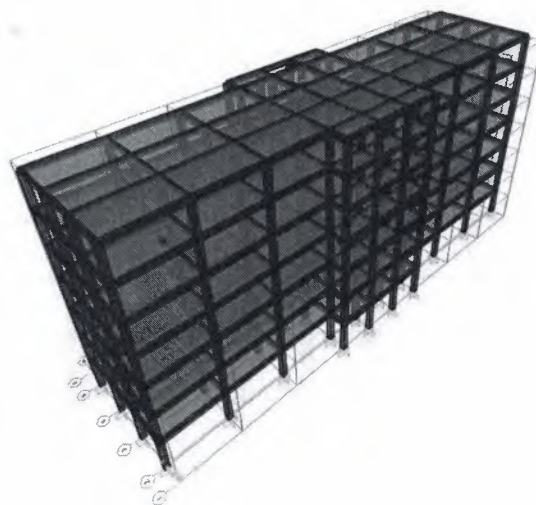

Figure 3.4: 3D Model

3.6.3 Defining Load Patterns and Assigning Load Magnitudes

The load patterns defined were live and dead loads (gravity loads) Different load combinations were defined to enable the determination of the critical load on the structure. The self weight of beams and columns (dead load) was calculated automatically by the program based on their dimensions. The live load and weight of the walls and partitions on the beams were assigned as uniformly distributed loads in kN/m. However the dead load and live load on the slabs were assigned as uniform area load (kN/m^2). Analysis was based full live load scenario only.

3.6.4 Running the Analysis

Owing to the climatic conditions in Kano Nigeria, snow, wind and earthquake loads were not considered only live and dead loads were considered. Analysis was run and axial load and moments acting on the columns for different loads combinations as stipulated by the codes were obtained as shown in the Figure 3.5.

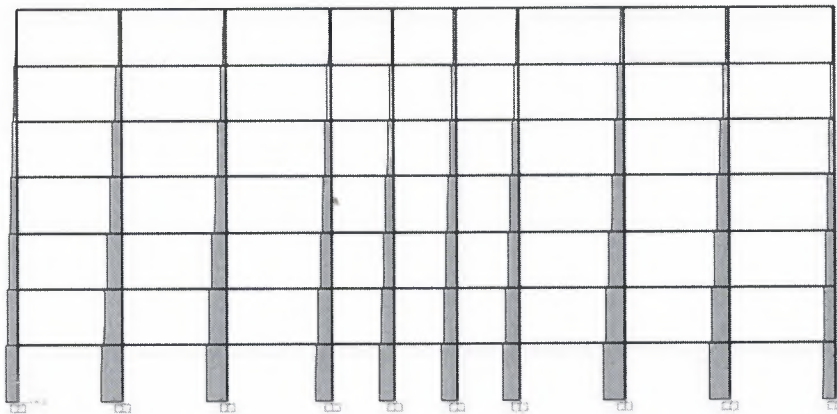

Figure 3.5: Axial Forces on Columns

3.7 Method of Design

The computer package PROKON 32 was employed for the design of the columns on account of its widespread use amongst practicing structural and geotechnical engineers in Sub-Saharan Africa. Prokon is a program used for the structural analysis and design for timber, concrete and steel according a number of design codes. This program is able to design individual structural members such as rectangular columns, concrete slabs footings and retaining walls separately a according a number of design codes. Prokon provides a friendly graphical user interface for continuous error checking during the input, the tabular editor makes easy to find and fix input problems.

It was felt that this fact alone should justify its reliability for the present study. However as a preliminary exercise, three types of columns; a corner column, side column and an internal column were designed manually according to the two codes to check the validity and correctness of the result.

With the results of the structural analysis with different combinations of live and dead loads, corner, side and inner columns were designed using Prokon. The program indentifies the most critical loading automatically. The columns were considered to be compression members.

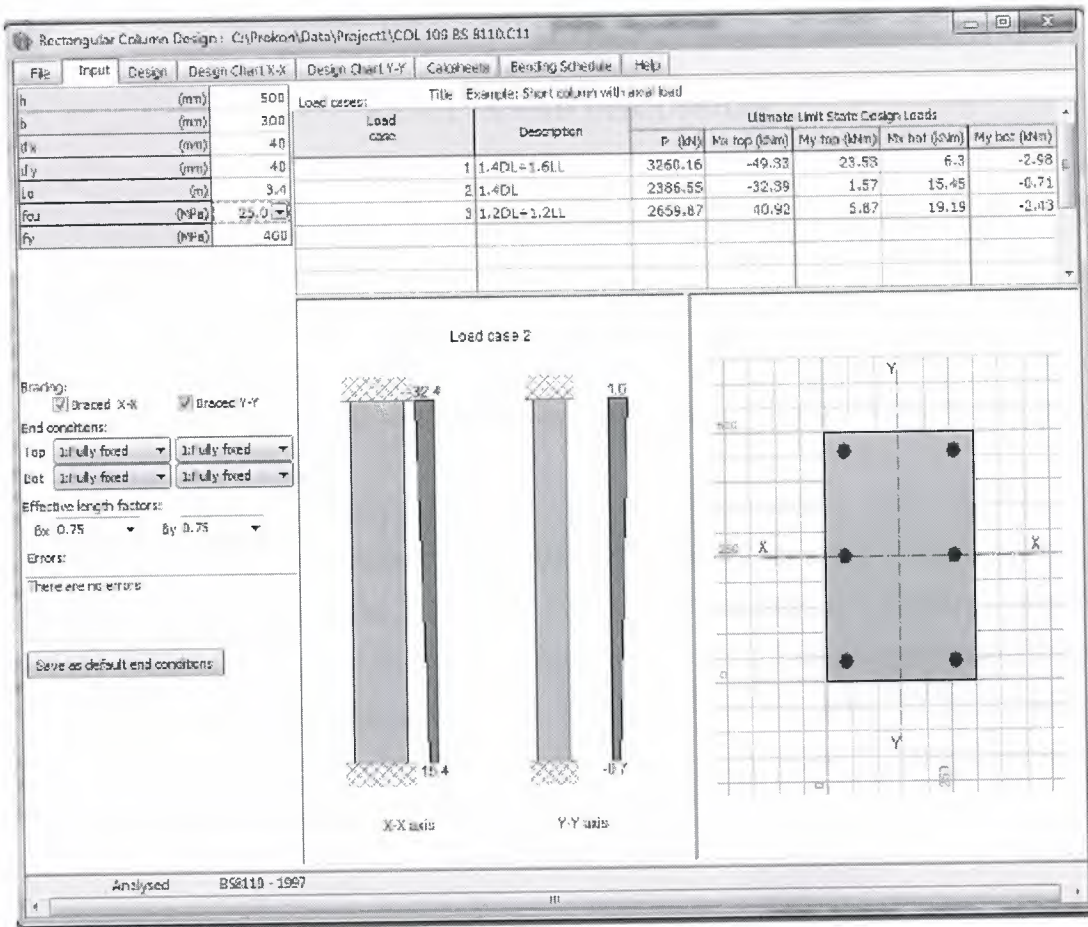

Figure 3.6 Prokon input GUI

CHAPTER 4

RESULTS AND DISCUSSION

4.1 Comparison of Column Design Output

The results of the design of the columns of the building according to BS 8110-97 and ACI 318M-11 for the most critical load cases as determined automatically by the Prokon program are presented in this chapter.

For comparative analysis, the percentage difference between the areas of steel required was calculated for each design case. The BS 8110-97 values are kept as a baseline, therefore a positive value of percentage difference indicates that the amount of steel required by BS 8110-97 is less than that required by ACI 318M-11 and vice-versa. To further illustrate these results, graphs of area of steel required by each design codes for selected corner, side and inner columns were plotted.

4.2 Comparison of Area of Steel Required For Corner Columns

4.2.1 Percentage Difference in Area of Steel Required For Corner Columns

Table 4.1 gives the percentage difference between the areas of steel required by the two codes for all corner columns. An average of these values is also presented.

Table 4.1: Percentage Difference in Area of Steel Required for Corner Columns

Col ID	C01	C03
Percentage Difference	14.23	17.81
Average	16.06	

The area of steel required for corner columns C03 at different floors in the building by both codes with their percentage differences are presented in Table 4.2. These are also illustrated graphically in Figure 4.1.

Table 4.2: Area of Steel Required Column 03 (Corner Column)

COL ID	As req.(mm ²)		Percentage difference	
	ACI	BS		
103	1878	2379	-21.0593	
203	2624	2351	11.61208	
303	2187	2013	8.643815	
403	2131	1788	19.18345	
503	2159	1661	29.98194	
603	2131	1497	42.35137	
703	4888	3648	33.99123	
			Average	17.81

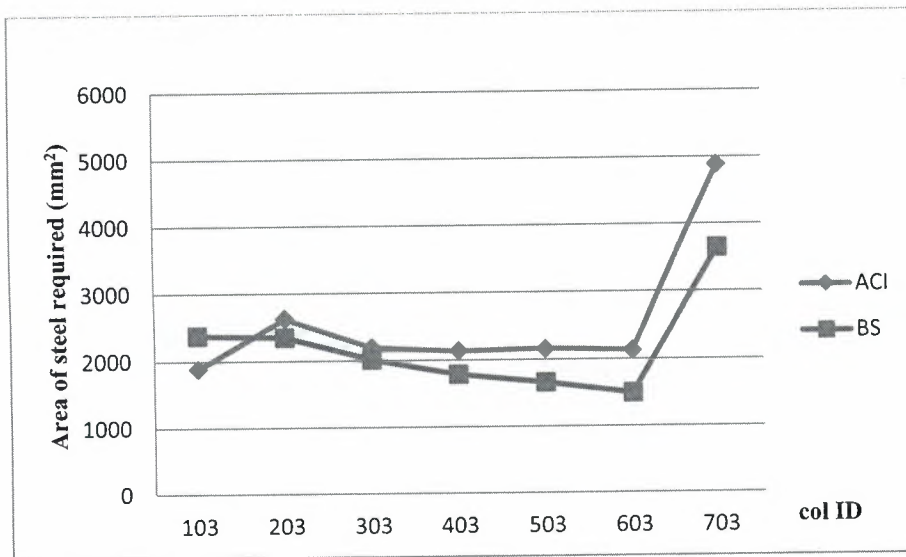

Figure 4.1: Area of Steel Required For Column 03 (Corner Column)

4.3 Area of Steel Required for Side Columns

4.3.1 Percentage Difference in Area of Steel Required for Side Columns

Table 4.3 gives the percentage difference between the areas of steel required by the two codes for all side columns. An average of these values is also presented.

Table 4.3: Percentage Difference in Area of Steel Required for Side Columns

Col ID	C02	C04	C07
Percentage Difference	3.83	-5.16	-17.45
Average	-6.26		

The area of steel required for side columns C07 at different floors in the building by both codes with their percentage differences are presented in Table 4.4. These are also illustrated graphically in Figure 4.2.

Table 4.4: Area of Steel Required for Column 07 (Side Column)

COL ID	As req.(mm ²)		Percentage difference	
	BS	ACI		
107	3714	3472	-6.51	
207	3566	2987	-16.23	
307	3045	2245	-26.27	
407	2895	2133	-26.32	
507	2453	1978	-19.36	
607	1947	1642	-15.67	
707	4487	3959	-11.77	
			Average	-17.45

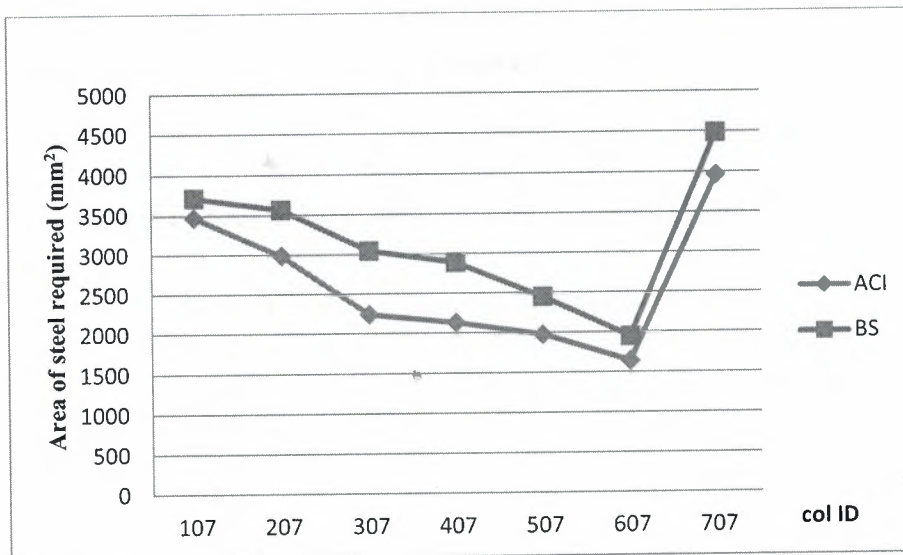

Figure 4.2: Area of Steel Required for Column 07 (Side Column)

4.4 Comparison of Area of Steel Required for Inner Columns

4.4.1 Percentage Difference in Area of Steel Required for Inner Columns

Table 4.5 gives the percentage difference between the areas of steel required by the two codes for all corner columns. An average of these values is also presented.

Table 4.5: Percentage Difference in Area of Steel Required for Inner Columns

Col ID	C05	C06	C08	C09	C10
Percentage Difference	-5.48	-11.36	-17.35	-18.02	4.55
Average	-9.532				

The area of steel required for corner columns C09 at different floors in the building by both codes with their percentage differences are presented in Table 4.6. These are also illustrated graphically in Figure 4.3.

Table 4.6: Area of Steel Required for Column 09 (Inner Column)

COL ID	As req.(mm ²)		Percentage difference	
	BS	ACI		
109	6984	6189	12.85	
209	5072	5008	1.28	
309	3197	3771	-15.22	
409	1566	2814	-44.35	
509	1209	2121	-42.99	
609	1209	1483	-18.48	
709	1809	2241	-19.22	
			Average	-18.03

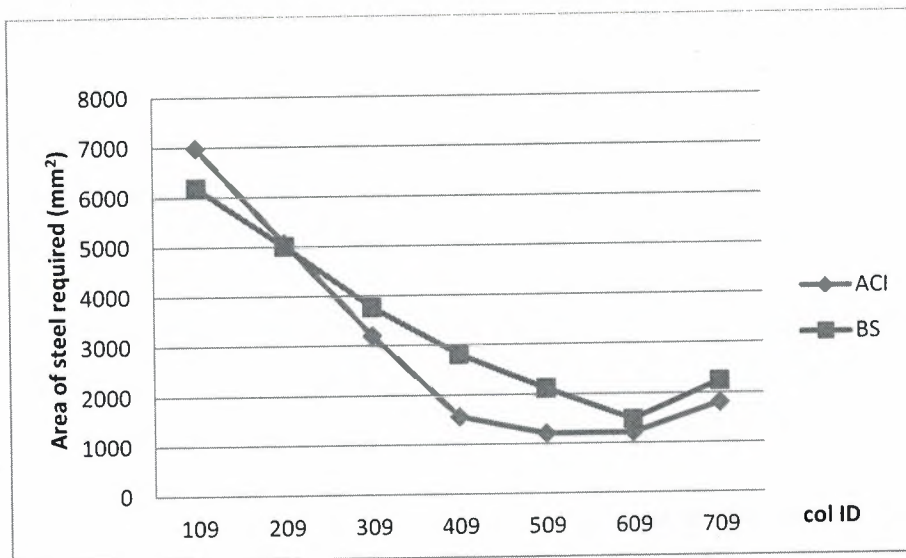

Figure 4.3: Area of Steel Required for Column 09 (Inner Column)

4.5 Discussion of Results

The percentage difference between the areas of steel required by the two codes was calculated with the BS code as the base line. For the combination of dead and imposed loads considered in this study; the average percentage difference for corner, side and inner columns are about 16%, -6% and -9.5% respectively. The overall average for all columns was found to be about -3.45%.

Side and inner columns were observed to be supporting high axial load plus bending in both directions. Corner columns carry relatively lower axial load and bending in both axes.

The results show that ACI code requires more area of steel for corner columns which supports relatively lower axial loads, but for inner and side columns with higher axial loads the BS code requires more.

This difference in trend is attributed to the different manner adopted by both codes to determine the design loads. In BS 8110 design moment are determined as the moment in either the major or minor axis increased by a certain percentage (β) of the moment from the other direction as opposed to the approximate methods used by the ACI 318. Therefore the design moments considered by ACI 318 are much lesser.

Also the column interaction chart is another factor that cause these differences, although direction compression between the two is not possible because they employ different approaches, studies have shown it has an effect on the final design output.

The BS8110 code applies larger partial safety factors to loads at the ultimate limit state in contrast to ACI 318. For the latter, the partial safety factor with respect to dead loads is marginally lower compared with the BS8110 value.

The amount of steel required was found to decrease with increase in the compressive strength of concrete for both codes even the percentage difference between the areas of steel required by the two codes remained relatively constant. However the reverse was the case when the column size was varied, less areas of steel were required for column with larger dimensions.

CHAPTER 5

SUMMARY, CONCLUSIONS AND RECOMMENDATIONS

5.1 Summary and Conclusions

In the absence of a national design code, the structural engineers in Nigeria use the BS 8110, Euro code 2, ACI 318 and quite a number of other structural design codes for the design of reinforced concrete structures. However, these engineers frequently compare the stipulations in these codes seeking points of similarities and differences. Economy is also a major point of concern.

This study compared BS 8110-97 and ACI 318M-11 in terms of the design of short column with particular emphasis on the area of longitudinal reinforcements required, with the aim of determining which of the two codes provides the most economic design. The super structure of a seven storey hospital building was modeled and analysed using SAP 2000 program taking into consideration only dead and imposed loads and assuming only one scenario (full) for live loads. The result of the analysis was used to design the columns with the aid of Prokon 32 suite of programmes.

The results of this comparative study led to the following conclusions:

- i. The basic design principles of the two codes are the same; they are both based on the limit-states design principle. Their design approaches are very similar; both are aimed at designing safe and economic structures. The only differ in details.
- ii. The ACI code is more conservative in terms of the partial factors of safety for loads, for a combination of live and dead load considered in this study, the BS code require about 12% more than that of the ACI code.
- iii. ACI code requires more area of steel for corner columns which supports relatively lower axial loads, but for inner and side columns with higher axial loads the BS code requires more.

- iv. Considering the fact that the overall average for all columns was found to be about -3%, design of the columns using the ACI code is more economical as it requires less reinforcement than the BS code.

5.2 Recommendations

- i. The ACI code is recommended over the BS code for the design of short columns in Nigeria as it provides a more economical design with the required safety.
- ii. As some of the provisions of these codes do not tally with the conditions in Nigeria, there is a need for Nigeria to develop its own national codes which will be suitable to its conditions.

REFERENCES

- ACI Committee, American Concrete Institute, & International Organization for Standardization. (2011). Building code requirements for structural concrete (ACI 318-11) and commentary. American Concrete Institute.
- Adiyanto, M. I., Majid, T. A., & Zaini, S. S. (2008). Analysis and design of 3 storey hospital structure subjected to seismic load using STAAD PRO. *In proceedings of the International conference on construction and building technology*, (pp.377-388). Malaysia: Universiti Sains Malaysia.
- Ahmad A., J. (2010). Comparative studies of reinforcement concrete beam design using BS 8110 and ACI 318. Doctoral dissertation, Universiti Malaysia Pahang.
- Ajayi, O. O., Fagbenle, R. O., Katende, J., Aasa, S. A., & Okeniyi, J. O. (2013). Wind profile characteristics and turbine performance analysis in Kano, north-western Nigeria. *International Journal of Energy and Environmental Engineering*, 4(1), 1-15.
- Allen, A. (2002). Reinforced Concrete Design to BS 8110 Simply Explained. CRC Press.
- Alnuaimi, A. S., & Patel, I. Y. (2013). Serviceability, limit state, bar anchorage and lap lengths in ACI318: 08 and BS8110: 97: A comparative study. *Indian Concrete Journal*, 30.
- Alnuaimi, A. S., Patel, I. I., & Al-Mohsin, M. C. (2012). Design results of rc members subjected to bending, shear, and torsion using ACI 318: 08 and BS 8110: 97 building codes. *Practice Periodical on Structural Design and Construction*, 18(4), 213-224.
- American Society of Civil Engineers, (2010). Minimum design loads for buildings and other structures, ASCE 7-10. Reston, VA: American Society of Civil Engineers.
- Ariffin, K., & Mahpal, M. (2010). Comparison of slab design between BS 8110 and Eurocode 2 by using Microsoft excel. Doctoral Dissertation, Universiti Malaysia Pahang.

Arya, C. (2009). Design of structural elements: concrete, steelwork, masonry and timber designs to British standards and Eurocodes. CRC Press.

Atiyah R. S. (2013). General comparison and evaluation of TEC-2007 and EC8 Using Sta4-Cad V12.1 in respect of cost estimation. Masters Thesis, Near East University TRNC.

British Cement Association, (1994). Worked examples for the design of concrete buildings. BCA Publication 43.505, British Cement Association, Crowthorne, (pp.258).

British Standards Institution, (1997). BS8110 - 1997 Structural use of concrete, Part 1: code of practice for design and construction. British Standards Institution, London.

Choi, K. K. (2002). Reinforced concrete structure design assistant tool for beginners. Doctoral dissertation, University of Southern California.

Choo, B. S., & MacGinley, T. J. (2002). Reinforced concrete: design theory and examples. CRC Press.

Cook, N. (2009). Wind loading: A practical guide to BS 6399-2. Thomas Telford Limited.

Dorsey, N. J. (2008). Flexural comparison of the ACI 318-08 and AASHTO LRFD structural concrete codes. Master's Theses and Graduate Research at San Jose State University ScholarWork.

Habibullah, A., & Wilson, E. (2005). SAP 2000 static and dynamic finite element analysis of structures. Computers and Structures Inc. Berkeley, California.

Jamaludin, A. (2010). Comparative studies of reinforced concrete beam design using BS 8110-97 And ACI 318-05. *FYP, Universiti Malaysia Pahang*.

Jawad A. A. (2006). Strength design requirements of ACI-318M-02 Code, BS8110, and EuroCode2 for structural concrete: A comparative Study. *Journal of Engineering and Development, 10(1)*, 22-28.

- Liew Y. H. (2009). British standard (BS 8110) and Eurocode 2 (EC2) for reinforced concrete column design. University of Technology Malaysia.
- Mac Gregor, J. C. (2012). Reinforced concrete mechanics and design, Sixth Edition. Pearson Education.
- McCormac, J. C., & Nelson, J. K. (2014). Design of reinforced concrete. ACI 318-11 Code Edition. Wiley. (pp.281).
- Nawy, E. (2005). Reinforced Concrete. Fifth edition. Pearson Prentice Hall. United States of America. (pp.714).
- Nawy, E. (2006). Prestressed concrete: A fundamental approach, 5th ed. Upper Saddle River, NJ: Prentice-Hall, (pp.38).
- Nilson, A. (1997). Design of concrete structures (12th Edition). McGraw-Hill, Inc.
- O'Brien, E.J. and A.S. Dixon, (1995). Reinforced and prestressed concrete design the complete process, 1st Edition. Longman Scientific and Technical, United Kingdom, (pp.492)
- Osagie, E. O. (2008). Seismic activity in Nigeria. *The Pac Journal of Science and Technology*, 9(2), 1-6.
- Reynolds, C. E., & Steedman, J. C. (2003). Examples of the design of reinforced concrete buildings to BS8110. CRC Press.
- Reynolds, C.E., J.C. Steedman & A.J. Threlfall, (2008). Reynolds's Reinforced Concrete Designer's Handbook, 11th Edition. Taylor and Francis, London, (pp401).
- Shah, H. J., & Jain, S. K. (2009). Design example of a six storey building. Department of Applied Mechanics MS University of Baroda, Vadodara.

Shodolapo O. F. & Kenneth K. M. (2011). A comparative study of EC2 and BS8110 beam analysis and design in a reinforced concrete four storey building. *Journal of Basic and Applied Scientific Research*, 1(12), 3172-3181.

Sia, K. S. (2010). Comparative study of reinforced concrete design of column between American Code (ACI 318-05) and British Standard (BS 8110-97). Universiti Malaysia Pahang.

Standard Loadings for Buildings (BS 6399), (2004). Part 2: code of practice for wind loads (as Amended)(2005). Building and Civil Engineering Sector Board, United Kingdom.

Tay, G. L. (2013). Design of retaining walls based on Eurocode 7 and BS standards. Nanyang Technological University Singapore.

Yaosheng Y. (2009). British standard and Eurocode for slender reinforced concrete column design. Nanyang Technological University Singapore.

APPENDIX

ANALYSIS RESULTS

ACI 318M-11

1.4DL

COL ID	P(kN)	Mx top (kN/m ²)	Mx bot (kN/m ²)	My top (kN/m ²)	My bot (kN/m ²)
103	1262.21	43	-20	18.26	-8
203	1091.42	56.31	-60.15	26.1	-26.6
303	914.82	56.08	-54.37	28.24	-26.98
403	734.7	57.67	-57.66	30.53	-29.93
503	551.49	61.18	-59.35	33.06	-32
603	366.44	50.94	-57.16	29.91	-32.05
703	177.81	103.87	-73.22	54.06	-40

COL ID	P(kN)	Mx top (kN/m ²)	Mx bot (kN/m ²)	My top (kN/m ²)	My bot (kN/m ²)
107	1768.29	60	-28.76	0.7	-0.34
207	1513.01	78	-84.23	3.5	-2.3
307	1258.69	78.25	-76.08	6.16	-5.42
407	1005.62	80.26	80.25	8.15	-7.5
507	753.41	84.56	-82.23	9.6	-9
607	501.94	71.48	-79.39	10.64	-10.31
707	250.67	140.81	-100.78	14.11	-12.45

COL ID	P(kN)	Mx top (kN/m ²)	Mx bot (kN/m ²)	My top (kN/m ²)	My bot (kN/m ²)
109	2386.55	-32.39	1.57	15.45	-0.71
209	2031.86	-45.24	5.48	46	-3.82
309	1684.76	-46.62	9.27	45.25	-8.08
409	1343.15	-49.03	12.28	48.43	-11.27
509	1006.13	-51.48	14.68	50.49	-13.9
609	672.28	-48.21	15	50.39	-15
709	342.34	-77.01	21.79	60.91	-18.75

ACI 318M-11

1.2DL+1.6LL

COL ID	P(kN)	Mx top (kN/m ²)	Mx bot (kN/m ²)	My top (kN/m ²)	My bot (kN/m ²)
103	1342.15	50.23	-10.76	-23.96	22.57
203	1163.49	65.67	-33.15	-70.16	32.95
303	976.56	65.54	-34.37	-63.49	36.11
403	785.57	67.49	-38.51	-67.45	39.4
503	589.98	71.74	-41.52	-69.54	42.93
603	391.79	59.57	-41.77	-66.98	39.07
703	197.89	122.32	-85.96	70.41	-52.74

COL ID	P(kN)	Mx top (kN/m ²)	Mx bot (kN/m ²)	My top (kN/m ²)	My bot (kN/m ²)
107	2071.28	82.93	-39.56	3.29	-1.57
207	1771.32	108.57	-115.84	8.2	-6.4
307	1472.32	107.58	-104.62	11.68	-10.55
407	1176.25	110.32	-110.3	14.57	-13.6
507	880.98	116.15	-113.11	16.76	-16.08
607	586.83	98.32	-109.09	17.8	-17.58
707	293.04	193.4	-138.36	25.06	-21.37

COL ID	P(kN)	Mx top (kN/m ²)	Mx bot (kN/m ²)	My top (kN/m ²)	My bot (kN/m ²)
109	2919.2	-44.7	21.32	6.1	-2.91
209	2481.54	-62.42	64.31	13.25	-11.02
309	2055.29	-64.29	62.42	18.8	-16.95
409	1637.22	-67.58	66.76	23.34	-21.85
509	1225.94	-70.92	69.57	27.2	-25.81
609	819.36	-66.43	69.43	28.09	-28.11
709	418.51	-105.97	83.86	40.51	-34

ACI 318M-11

0.9DL

COL ID	P(kN)	Mx top (kN/m ²)	Mx bot (kN/m ²)	My top (kN/m ²)	My bot (kN/m ²)
103	811.38	27.64	-12.85	11.73	-5.14
203	701.59	36.19	-38.66	16.77	-17.09
303	588.07	36.04	-34.95	18.15	-17.34
403	472.28	37.07	-37.06	19.62	-19.23
503	354.51	39.32	-38.15	21.25	-20.57
603	235.55	32.74	-36.74	19.22	-20.60
703	114.30	66.77	-47.06	34.75	-25.71

COL ID	P(kN)	Mx top (kN/m ²)	Mx bot (kN/m ²)	My top (kN/m ²)	My bot (kN/m ²)
107	1136.71	38.56	-18.78	0.49	-0.218
207	972.60	50.14	-54.14	2.24	-1.47
307	809.12	50.30	-48.90	3.95	-3.48
407	646.44	51.59	51.58	5.23	-4.82
507	484.31	54.357	-52.86	6.17	-5.78
607	322.66	45.94	-51.03	6.83	-6.62
707	161.13	90.51	-64.78	9.07	-8.00

COL ID	P(kN)	Mx top (kN/m ²)	Mx bot (kN/m ²)	My top (kN/m ²)	My bot (kN/m ²)
109	1534.49	-20.82	1.09	9.93	-0.45
209	1306.43	-29.08	3.52	29.57	-2.45
309	1083.16	-29.96	5.95	29.08	-5.19
409	863.86	-31.51	7.89	31.13	-7.24
509	646.77	-33.09	9.43	32.45	-8.93
609	432.25	-30.99	9.64	32.39	-9.64
709	220.68	-49.50	14.00	39.15	-12.05

ACI 318M-11

1.2DL+1.0LL

COL ID	P(kN)	Mx top (kN/m ²)	Mx bot (kN/m ²)	My top (kN/m ²)	My bot (kN/m ²)
103	1244.62	46.57	-9.97	-22.21	20.91
203	1078.94	60.89	-30.74	-65.06	30.55
303	905.59	60.77	-31.87	-58.87	33.48
403	728.48	62.58	-35.71	-62.54	36.53
503	547.10	66.52	-38.50	-64.48	39.81
603	363.31	55.24	-38.73	-62.11	36.23
703	183.50	113.43	-79.71	65.29	-48.90

COL ID	P(kN)	Mx top (kN/m ²)	Mx bot (kN/m ²)	My top (kN/m ²)	My bot (kN/m ²)
107	1862.93	74.58	-35.58	2.95	-1.412
207	1593.14	97.64	-104.18	7.37	-5.75
307	1324.21	96.75	-94.09	10.50	-9.48
407	1057.93	99.22	-99.20	13.10	-12.23
507	792.36	104.46	-101.73	15.07	-14.46
607	527.80	88.42	-98.11	16.00	-15.81
707	263.56	173.94	-124.44	22.53	-19.22

COL ID	P(kN)	Mx top (kN/m ²)	Mx bot (kN/m ²)	My top (kN/m ²)	My bot (kN/m ²)
109	2591.82	-39.68	18.92	5.415	-2.58
209	2203.24	-55.41	57.097	11.76	-9.78
309	1824.79	-57.08	55.41	16.69	-15.04
409	1453.61	-60.00	59.27	20.72	-19.39
509	1088.45	-62.96	61.76	24.14	-22.91
609	727.47	-58.98	61.64	24.93	-24.95
709	371.57	-94.08	74.45	35.96	-30.18

BS 8110-97

1.4DL

COL ID	P(kN)	Mx top (kN/m ²)	Mx bot (kN/m ²)	My top (kN/m ²)	My bot (kN/m ²)
103	1262.21	43	-20	18.26	-8
203	1091.42	56.31	-60.15	26.1	-26.6
303	914.82	56.08	-54.37	28.24	-26.98
403	734.7	57.67	-57.66	30.53	-29.93
503	551.49	61.18	-59.35	33.06	-32
603	366.44	50.94	-57.16	29.91	-32.05
703	177.81	103.87	-73.22	54.06	-40

COL ID	P(kN)	Mx top (kN/m ²)	Mx bot (kN/m ²)	My top (kN/m ²)	My bot (kN/m ²)
107	1768.29	60	-28.76	0.7	-0.34
207	1513.01	78	-84.23	3.5	-2.3
307	1258.69	78.25	-76.08	6.16	-5.42
407	1005.62	80.26	80.25	8.15	-7.5
507	753.41	84.56	-82.23	9.6	-9
607	501.94	71.48	-79.39	10.64	-10.31
707	250.67	140.81	-100.78	14.11	-12.45

COL ID	P(kN)	Mx top (kN/m ²)	Mx bot (kN/m ²)	My top (kN/m ²)	My bot (kN/m ²)
109	2386.55	-32.39	1.57	15.45	-0.71
209	2031.86	-45.24	5.48	46	-3.82
309	1684.76	-46.62	9.27	45.25	-8.08
409	1343.15	-49.03	12.28	48.43	-11.27
509	1006.13	-51.48	14.68	50.49	-13.9
609	672.28	-48.21	15	50.39	-15
709	342.34	-77.01	21.79	60.91	-18.75

BS 8110-97

1.4DL+1.6LL

COL ID	P(kN)	Mx top (kN/m ²)	Mx bot (kN/m ²)	My top (kN/m ²)	My bot (kN/m ²)
103	1522.47	56.38	-26.9	25.17	-12
203	1319.41	73.56	-78.72	36.7	-36.95
303	1107.85	73.55	-71.25	40.14	-38.22
403	890.53	75.73	-75.69	43.76	-42.78
503	668.74	80.48	-78.01	47.65	-46.08
603	444.14	66.85	-75.15	43.35	-46.35
703	214.31	137.16	-96.42	78.13	-58.51

COL ID	P(kN)	Mx top (kN/m ²)	Mx bot (kN/m ²)	My top (kN/m ²)	My bot (kN/m ²)
107	2323.89	91.54	-43.67	3.4	-1.62
207	1987.46	119.84	-127.88	8.5	-6.7
307	1652.64	118.76	-115.5	12.56	-11.33
407	1319.91	127.78	-121.76	15.74	-14.67
507	988.61	128.23	-124.87	18.13	-17.39
607	658.54	108.53	-120.43	19.31	-19.05
707	328.85	213	-152.76	27.07	-23.15

COL ID	P(kN)	Mx top (kN/m ²)	Mx bot (kN/m ²)	My top (kN/m ²)	My bot (kN/m ²)
109	3260.16	-49.33	23.53	6.3	-2.98
209	2771.8	-68.89	70.97	14.03	-11.57
309	2295.97	-70.95	68.88	20.13	-18.11
409	1829.1	-74.59	73.67	23.09	-23.45
509	1369.67	-78.28	76.78	29.12	-27.79
609	915.4	-73.32	76.62	30.34	-30.34
709	467.42	-116.97	92.57	43.62	-36.68

BS 8110-97

1.2DL+1.2LL

COL ID	P(kN)	Mx top (kN/m ²)	Mx bot (kN/m ²)	My top (kN/m ²)	My bot (kN/m ²)
103	1147.90	42.95	-20.28	18.97	-9.047
203	994.79	55.19	-59.35	27.67	-27.85
303	835.28	55.65	-53.72	30.26	-28.81
403	671.48	57.91	-57.06	32.99	-32.25
503	504.23	60.68	-58.81	35.92	-34.74
603	334.92	50.44	-56.61	32.68	-34.94
703	134.38	78.39	-55.58	40.75	-30.89

COL ID	P(kN)	Mx top (kN/m ²)	Mx bot (kN/m ²)	My top (kN/m ²)	My bot (kN/m ²)
107	1850.84	72.96	-34.78	2.70	-1.20
207	1582.89	95.42	-101.89	6.69	-5.35
307	1316.29	94.27	-91.99	10.32	-9.07
407	1051.23	101.92	-96.96	12.57	-11.68
507	787.69	102.76	-99.45	14.43	-13.85
607	524.79	86.48	-95.93	15.33	-15.17
707	199.37	112.18	-80.26	11.77	-9.98

COL ID	P(kN)	Mx top (kN/m ²)	Mx bot (kN/m ²)	My top (kN/m ²)	My bot (kN/m ²)
109	2659.87	40.92	19.19	5.87	-2.43
209	2261.43	-56.54	57.96	11.67	-9.43
309	1873.21	-57.88	56.19	16.48	-14.77
409	1492.31	-60.88	60.22	18.46	-19.13
509	1117.47	-63.84	62.68	23.86	-22.67
609	746.84	-59.87	62.54	24.53	-24.75
709	279.30	-62.83	17.77	49.69	-15.29

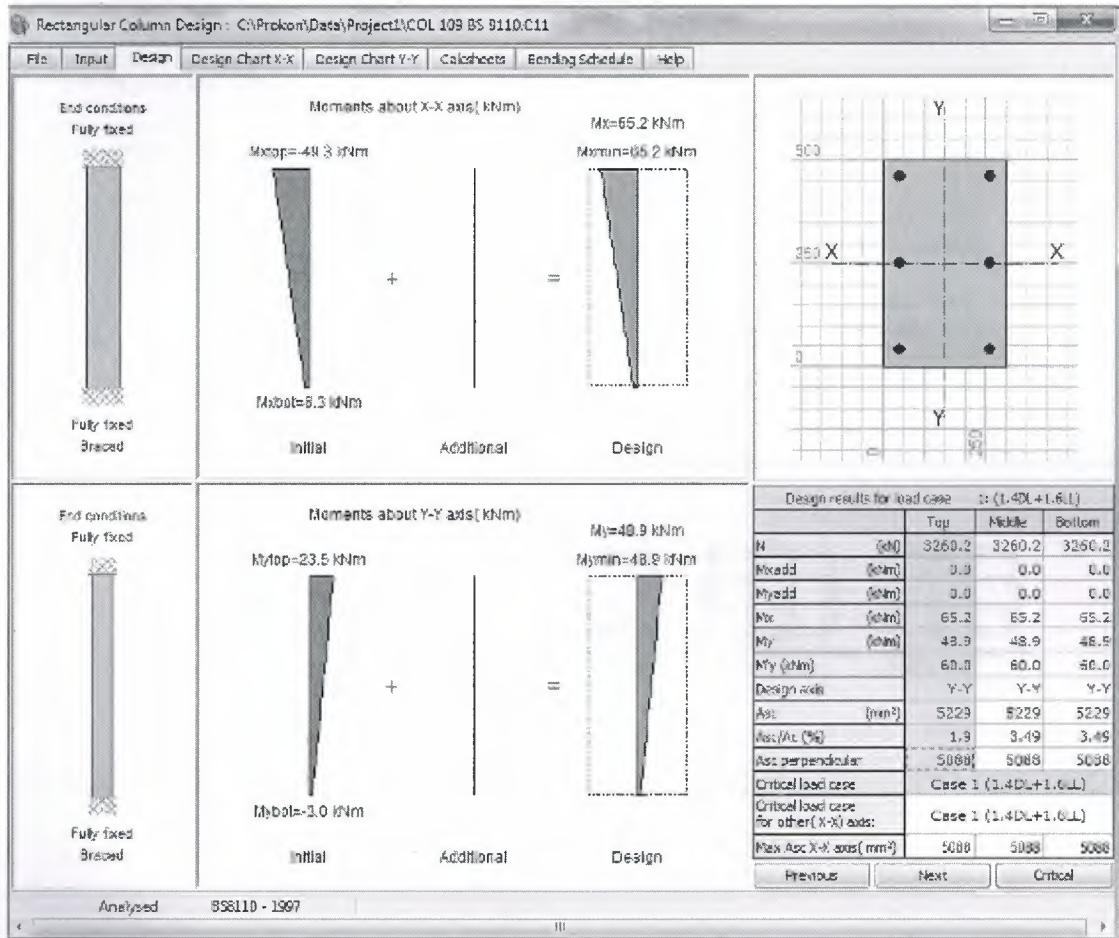

Figure 1: Prokon Design Page

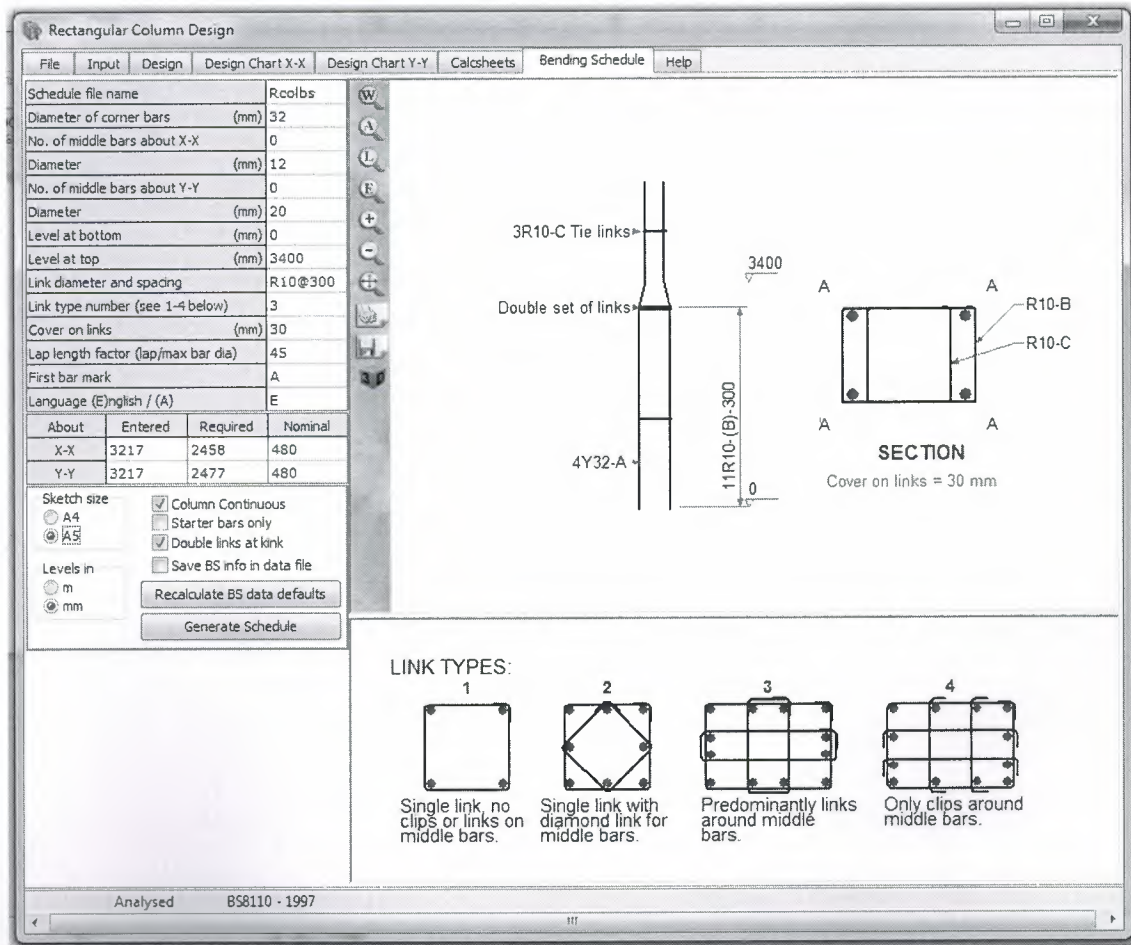

Figure 2: Prokon Bending Schedule