

Deuces Wild ARF

Assembly Manual



Specifications

Wingspan:	62 in (1570mm)
Length:	62.5 in (1580mm)
Wing Area:	740 sq in (47.7 sq dm)
Weight w/o Battery:	9.2-10.5 lb (4.2-4.7 kg)
Weight w/Battery:	7.75-8.5 lb (3.5-3.9 kg)



Table of Contents

Introduction.....	2
Using the Manual.....	2
Contents of Kit/Parts Layout.....	3
Recommended Radio Equipment.....	3
Required Tools and Adhesives.....	4
Notes Regarding Servos and ESC.....	4
Brushless Outrunner Setup, Power 25.....	4
Brushless Outrunner Setup, Power 32.....	4
Optional Accessories.....	4
Covering Colors.....	4
Note on Lithium Polymer Batteries.....	5
Warning.....	5
Fuselage Radio Installation.....	5
Tail Attachment.....	8
Rudder and Elevator linkage Installation.....	10
Aileron Servo Installation.....	16
Flap Servo Installation.....	21
Fixed Gear Installation.....	26
Retract Gear Installation.....	31
Retract Servo Installation.....	40
Aileron and Throttle Servo Extensions.....	46
Power 25 Motor Installation.....	48
Power 32 Motor Installation.....	49
Propeller and Spinner Installation.....	52
Wing Installation.....	56
Canopy and Gear Door Installation.....	57
Center of Gravity and Nose Cone Installation.....	59
Control Throws.....	60
Range Test Your Radio.....	61
Preflight.....	61
Flying Your Deuces Wild.....	62
Safety, Precautions, and Warnings.....	63
Warranty Information.....	63
Instructions for Disposal of WEEE by Users in the European Union.....	65
2008 Official AMA National Model Aircraft Safety Code ...	66

Introduction

The Deuces Wild 25e2 ARF is the first twin and the first sport plane in the Platinum Series. It is easier to fly than most other twins and exhibits gentle flight characteristics. Along with the superior features that come with every E-flite Platinum Series plane, the Deuces Wild is full of enhanced details. All flight control surfaces are installed, pushrods are pre-bent and ready for installation and it includes optional gear doors.

The Deuces Wild also comes with a unique wing design in that it utilizes two Selig airfoils to give it excellent performance at high and low speeds, while also giving the pilot gentle stall characteristics. It was even designed with the unthinkable in mind—the loss of an engine. In the event of an engine loss, this aircraft is still easily flyable. The lightweight sturdy frame is constructed of balsa and plywood and covered in genuine Hangar 9 UltraCote for added durability. The bolt-on tail assembly and removable wing panels are designed for quick building and easy storage.

Flight characteristics, aerobatic capabilities and amazing details—any experienced modeler would bet on the Deuces Wild.

Using the Manual

This manual is divided into sections to help make assembly easier to understand, and to provide breaks between each major section. In addition, check boxes have been placed next to each step to keep track of each step completed. Steps with a single circle (○) are performed once, while steps with two circles (○ ○) indicate that the step will require repeating, such as for a right or left wing panel, two servos, etc.

Remember to take your time and follow the directions.

Contents of Kit/Parts Layout

Replacement Parts

EFL4551L	Left Wing Panel
EFL4551C	Center Wing Panel
EFL4551R	Right Wing Panel
EFL4552	Fuselage
EFL4553	Tail Set
EFL4554L	Left Nacelle
EFL4554R	Right Nacelle
EFL4555	Landing Gear
EFL4556	Canopy
EFL4557	Pushrod Set
EFL4558	Spinner (Left Hand)
EFL4559	Spinner (Right Hand)
EFL4560	Wing Tube
EFL4561	Nose Cone
EFL4563	Strut Covers



Recommended Radio Equipment

You will need a minimum 6-channel transmitter, receiver, and six or seven servos. You can choose to purchase a complete radio system. If you are using an existing transmitter, just purchase the other required equipment separately. We recommend the crystalfree, interference-free Spektrum™ DX6i 2.4GHz DSM® 6-channel system. If using your own transmitter, we recommend the JR SPORT™ standard servos.

If you own the Spektrum DX6i radio, just add the AR6200 DSM2™ 6-channel receiver and six JR SPORT ST47 Standard Servos.

Complete Radio System

SPM6600	DX6i DSM2 6CH system
SPM2710	DX7 DSM2 7CH system

Or Purchase Separately

SPMAR6200	AR6200 DSM2 6-Channel Full-Range Receiver (for DX6i or DX7)
SPM6070	AR7000 DSM2 7-Channel Full Range Receiver (for DX6i or DX7)

And

JSP20050	ST47 Standard Servo (6, 7 w/retracts)
JSP98020	6-inch Y-Harness (3)
EFLREX3L	3-inch Extension, Lightweight (4)
EFLREX9L	9-inch Extension, Lightweight (2)
EFLREX12L	12-inch Extension, Lightweight (2)

The Spektrum trademark is used with permission of Bachmann Industries, Inc.

Required Tools and Adhesives

Tools & Equipment

Felt-tipped pen	Ball driver: 3/32-inch
Low-tack masking tape	Mixing sticks
Paper towels	Pin drill
Rubbing alcohol	Mixing cups
Hobby knife (#11 blade)	Pliers
Phillips screwdriver: #1, #2	Side cutters
Sandpaper	Nut driver: 1/4-inch
Pencil	Drill
Covering iron	Flat screwdriver
Dental floss	Scissors
Rotary tool w/high speed cutting bit	
Drill bit: 1/16-inch (1.5mm), 5/64-inch (2mm), 3/32-inch (2.5mm), 3/16-inch (5mm)	

Adhesives

Thin CA	Medium CA
Threadlock	6-Minute Epoxy (HAN8000)
Canopy glue	Silicone adhesive

Notes Regarding Servos and ESC

WARNING: Use of servos other than those we suggest may overload the BEC of the recommended Electronic Speed Control (ESC). Please use only the servos listed when utilizing the recommended ESC's BEC, or the use of a separate BEC (like the UBEC) or receiver battery pack when using other servos.

Brushless Outrunner Setup, Power 25

EFLM4025A (2 req)	Power 25 Brushless Outrunner Motor 870Kv
EFLA1060 (2 req)	60-Amp Pro Switch-Mode BEC Brushless ESC
EFLB32003S (2 req)	E-flite 3S 11.1V 3200mAh 20C Li-Po
APC12080E (1 req)	12x8 Electric Propeller
APC12080EP (1 req)	12x8 Electric Pusher Propeller

Brushless Outrunner Setup, Power 32

EFLM4032A (2 req)	Power 32 Brushless Outrunner Motor, 770Kv
EFLA1060 (2 req)	60-Amp Pro Switch-Mode BEC Brushless ESC
THP33004SXV (2 req)	4S 14.4V 3300mAh 25C Li-Po battery
APC13065E (1 req)	13x6.5 Electric Propeller
APC13065EP (1 req)	13x6.5 Electric Pusher Propeller

Optional Accessories

EFLA110	Power Meter
EFLC505	Intelligent 1- to 5-Cell Balancing Charger
EFL4562	Cockpit Kit, Deuces Wild ARF
EFL4565	Retracts, Deuces Wild ARF
DUB141	3/16-inch Wheel Collars (required for retract installation)

Covering Colors

White	HANU870
Flame Red	HANU883
Black	HANU874

Note on Lithium Polymer Batteries



Lithium Polymer batteries are significantly more volatile than alkaline or Ni-Cd/Ni-MH batteries used in RC applications. All manufacturer's instructions and warnings must be followed closely. Mishandling of Li-Po batteries can result in fire. Always follow the manufacturer's instructions when disposing of Lithium Polymer batteries.

Warning

An RC aircraft is not a toy! If misused, it can cause serious bodily harm and damage to property. Fly only in open areas, preferably at AMA (Academy of Model Aeronautics) approved flying sites, following all instructions included with your radio.

Keep loose items that can get entangled in the propeller away from the prop, including loose clothing, or other objects such as pencils and screwdrivers. Especially keep your hands away from the propeller.

Fuselage Radio Installation

Required Parts

Fuselage	Servo w/hardware (3)
Hook and loop tape	Receiver
3-inch (76mm) servo extension (3) (4 for optional retracts)	

Required Tools and Adhesives

Pin drill	Drill bit: 1/16-inch (1.5mm)
Thin CA	Phillips screwdriver: #1
Pencil	

1. Install the servo grommets and brass eyelets into your servos at this time. We feel it is easiest to prepare all the servos to save time later. If so, you will need all 6 or 7 servos for this step.

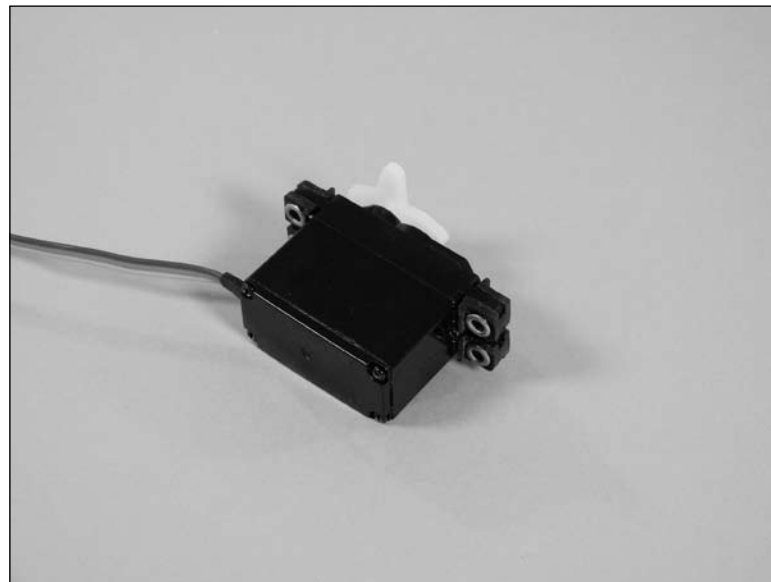

- 2. Position the elevator servo in the fuselage. Use a pencil to transfer the locations for the servo mounting screws to the servo tray.



- 3. Use a pin drill and 1/16-inch (1.5mm) drill bit to drill the four holes for the servo mounting screws.

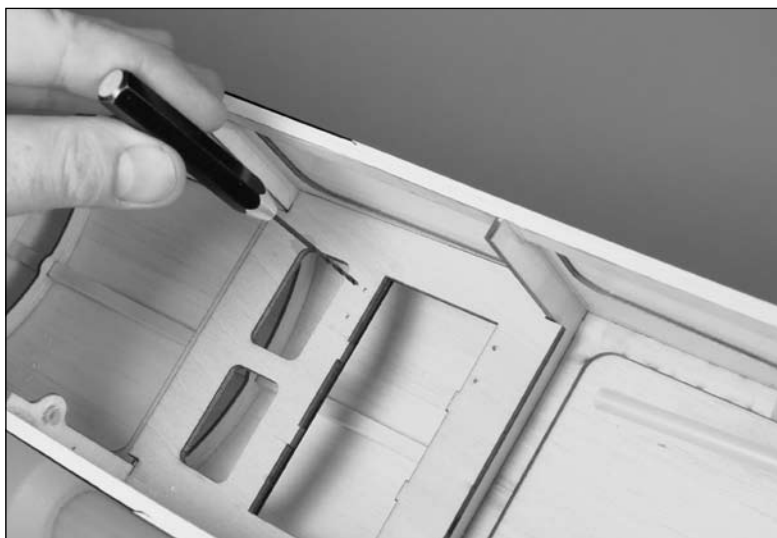

- 4. Apply 2–3 drops of thin CA into each of the holes to harden the surrounding wood. This will provide a harder surface for the screws to bite into when installed.



- 5. Secure the elevator servo in the fuselage using the hardware provided with the servo and a #1 Phillips screwdriver.

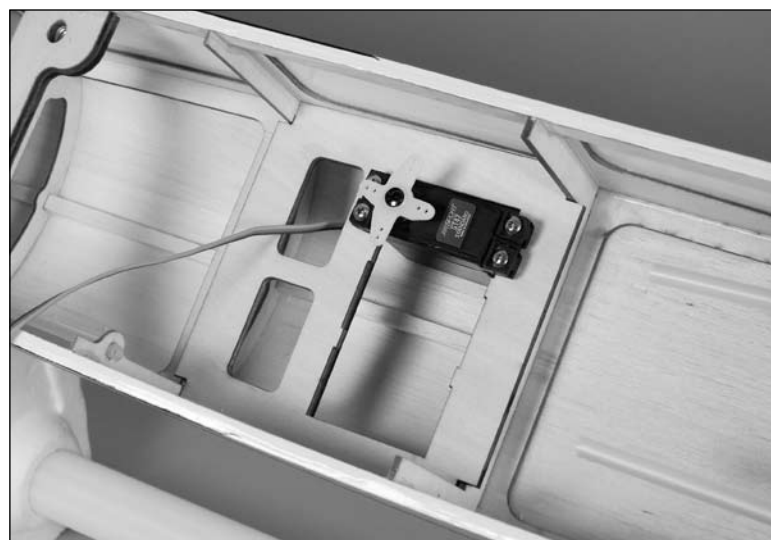

- 6. Repeat all of the previous steps to install the rudder servo and steering servo in the fuselage. Note that the steering servo is in the center location when installed. Please note the orientation of the servos in the fuselage.

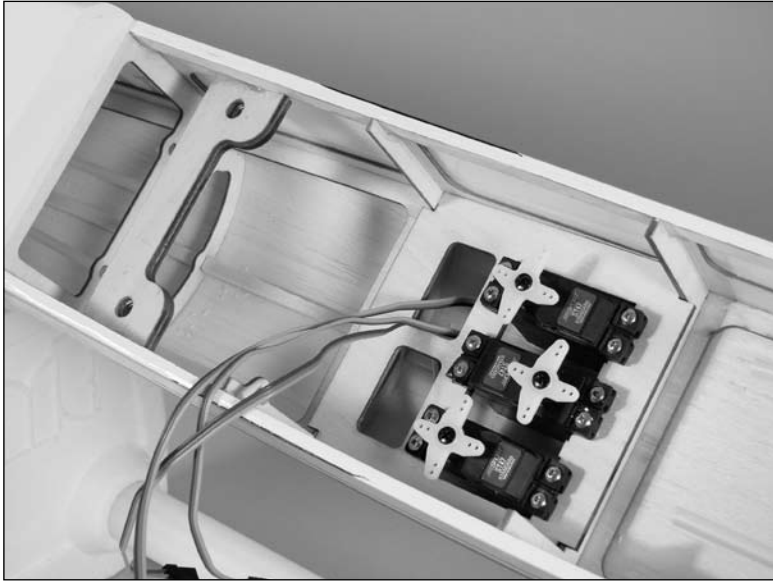

- 7. Use hook and loop tape to install the receiver into the fuselage. When installing a remote receiver, place it as far away from the main receiver as possible, aligning the antennas perpendicular to those of the main receiver.



Note: If you are using a standard 72MHz receiver, an antenna tube has been installed in the fuselage to route the antenna wire to the rear of the fuselage. Never cut the receiver antenna as this will greatly reduce the range of your radio system.

- 8. Plug a 3-inch (76mm) servo extension into the throttle, aileron and flap ports on the receiver at this time. This will make it easier to plug the leads that will be installed in the wing later while assembling your aircraft.

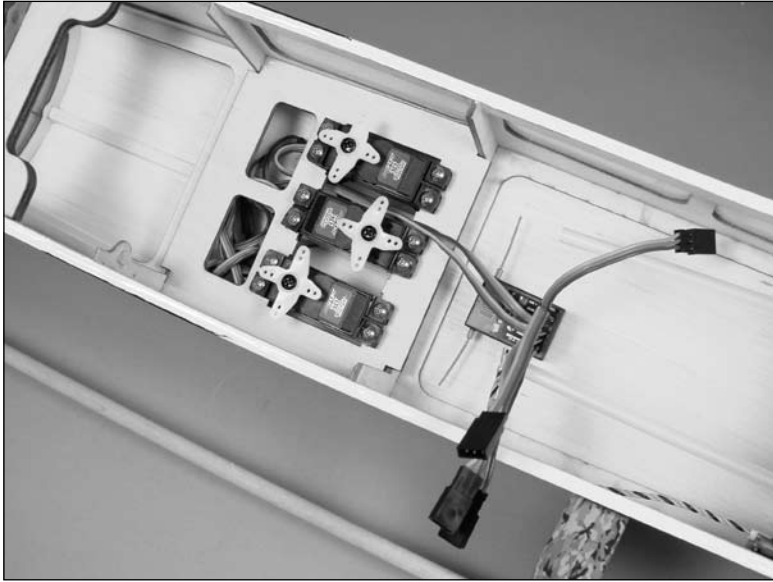

Note: If you are installing retracts, plug a 3-inch (76mm) extension into the port marked GEAR at this time as well.

Tail Attachment

Required Parts

Rudder/fin	Elevator/stabilizer
Fuselage assembly	Nylon control horn
4-40 lock nut (2)	#4 washer (2)

Required Tools and Adhesives

Nut driver: 1/4-inch

- 1. Thread the nylon control horn onto the rudder torque rod. You will thread this on until the end of the rod is flush with the nylon control horn.



- 2. Slide the threaded rods from the fin into the holes in the stabilizer. The fin will fit flush against the stabilizer when installed.

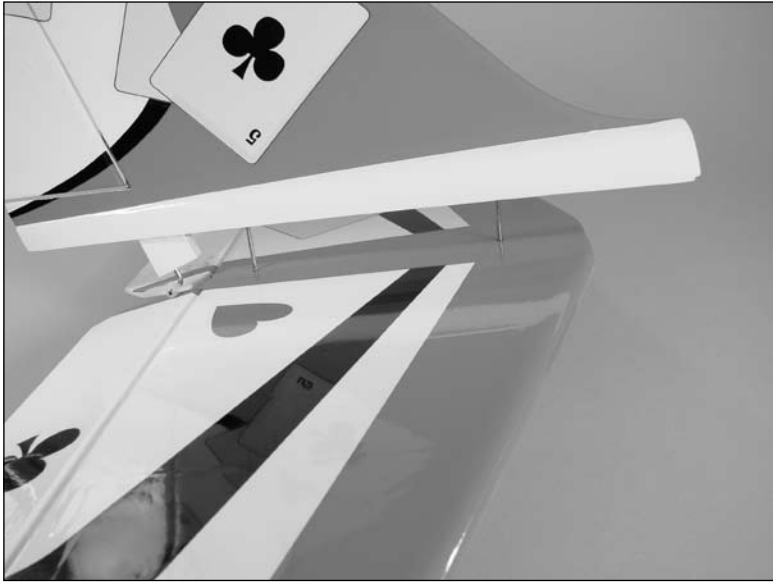

- 3. Slide the threaded rods into the holes in the rear of the fuselage.



- 4. Using a 1/4-inch nut driver, secure the tail assembly to the fuselage using two 4-40 lock nuts and two #4 washers. Do not over-tighten the nuts and damage the fuselage. At this time the Rudder/Fin, Stab/Elevator, and Fuselage should fit tight against each other.



Rudder and Elevator linkage Installation

Required Parts

Fuselage assembly
Silicone clevis retainer (2)
29³/₄-inch (755mm) pushrod wire (2)

Nylon clevis (2)
Nylon pushrod keeper (2)

Required Tools and Adhesives

Pin drill
Felt-tipped pen
Side cutters

Drill bit: 5/64-inch (2mm)
Pliers
Phillips screwdriver: #1

- 1. Thread a clevis onto one of the 29³/₄-inch (755mm) pushrod wires. Make sure to slide a silicone clevis retainer onto the clevis before threading it onto the pushrod wire.



- 2. Slide the pushrod wire into the pre-installed pushrod tube on the same side of the fuselage as the elevator control horn. Attach the clevis to the elevator control horn in the middle hole.



- 3. Use a pin drill and 5/64-inch (2mm) drill bit to enlarge the outer hole of the elevator servo horn.

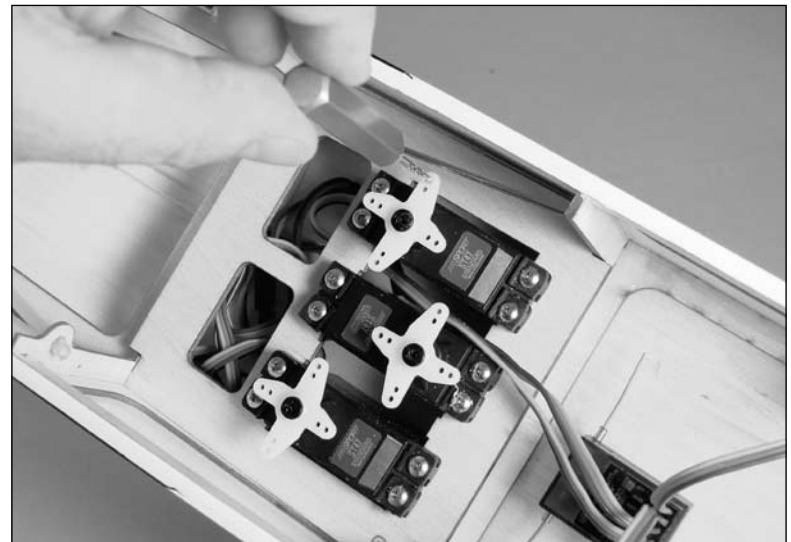

- 4. Center the elevator servo using the radio system. With the elevator in the neutral position, use a felt-tipped pen to mark the pushrod wire where it crosses the outside hole on the servo horn.

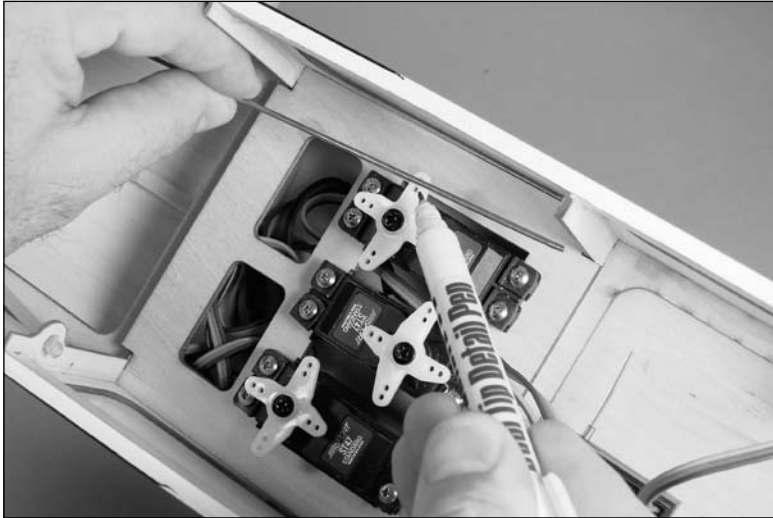

- 5. Use pliers to bend the pushrod wire 90 degrees at the mark made in the last step.



Note: Use side cutters to trim any arms that will interfere with the operation of the rudder servo.

- 6. Using a #1 Phillips to remove the servo horn from the servo. Slide the servo horn onto the pushrod wire with the splined part of the horn that fits onto the servo toward the bend.



- 7. Next, slide the pushrod keeper onto the wire. Slide the horn and keeper down so the horn is tight against the bend.



- 8. The notch in the pushrod keeper will snap onto the pushrod wire. This will keep the pushrod secure on the servo horn. You may need to use pliers to apply enough force to snap the pushrod keeper onto the wire.

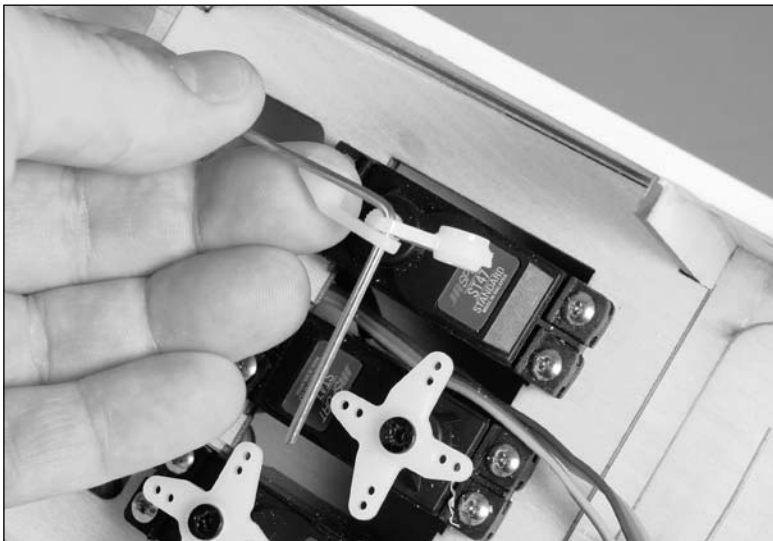

- 9. Use side cutters to remove any excess wire that extends beyond the connector. Leave a small amount of wire to prevent the keeper from popping off accidentally.



- 10. Rotate the pushrod wire 90 degrees so the servo horn aligns with the servo output shaft. Use a #1 Phillips screwdriver to reattach the servo horn to the elevator servo at the center position.



- 11. Thread a clevis onto one of the 29³/₄-inch (755mm) pushrod wires. Make sure to slide a silicone clevis retainer onto the clevis before threading it onto the pushrod wire.

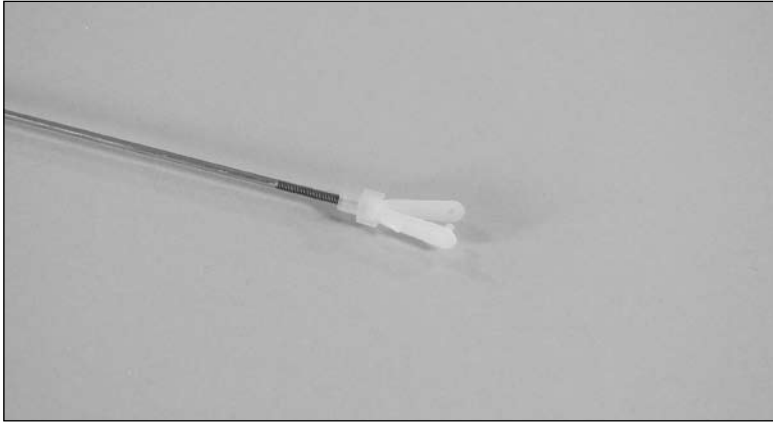

- 12. Slide the wire into the rudder pushrod tube and connect the clevis to the rudder servo horn. Plug a Y-harness into the receiver rudder port of your receiver. The rudder and nose wheel steering servo will plug into this Y-harness.



Note: Use side cutters to trim any arms that will interfere with the operation of the rudder servo.

- 13. Center the rudder servo using the radio system. With the rudder in the center position, use a felt-tipped pen to mark the pushrod where it crosses the hole in the rudder control horn.

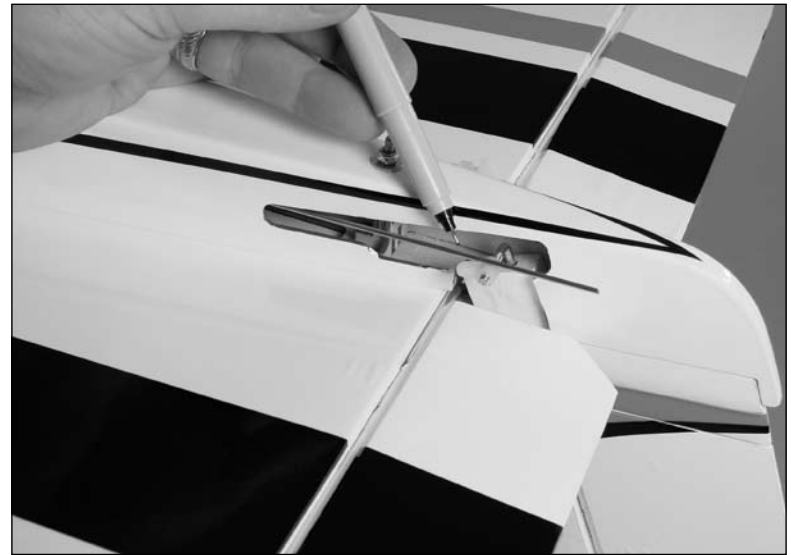

- 14. Make a 90 degree bend in the pushrod wire at the mark you made in Step 10.



- 15. Slide the pushrod wire through the hole in the rudder control horn. You will need to rotate the horn so it can be aligned with the pushrod for this step. Once the wire has been inserted, you can rotate the control horn so it is aligned with the pushrod wire.



- 16. Slide the pushrod keeper onto the wire. Position the wire so the bend in the wire is snug against the control horn as shown.



- 17. The notch in the pushrod keeper will snap onto the pushrod wire. This will keep the pushrod secure. You may need to use pliers to apply enough force to snap the pushrod keeper onto the wire.



- 18. Use side cutters to remove any excess wire that extends beyond the connector. Leave a small amount of wire to prevent the keeper from popping off accidentally.



- 19. Remove the pushrod keeper and rotate the pushrod 180 degrees. Insert the pushrod into the nylon control horn and reinstall the pushrod keeper. This is necessary so the keeper doesn't bind against the fuselage during the operation of the rudder.



Aileron Servo Installation

Required Parts

Wing panel (right and left)	Servo hatch (right and left)
Servo mounting block (4)	Servo w/hardware (2)
Nylon clevis (2)	Silicone clevis retainer (2)
Nylon pushrod keeper (2)	
2mm x 10mm self-tapping screw (8)	
4 1/4-inch (108mm) aileron pushrod wire (2)	

Required Tools and Adhesives

Pencil	6-minute epoxy
Drill	Pin drill
Phillips screwdriver: #1	Thin CA
Felt-tipped pen	Pliers
Mixing cups	Mixing sticks
Side cutters	Sandpaper
Drill bit: 1/16-inch (1.5mm), 5/64-inch (2mm)	

1. Use sandpaper to roughen the ends of the four servo mounting blocks. Doing so will allow the epoxy applied to them in the next step a better surface to adhere to.

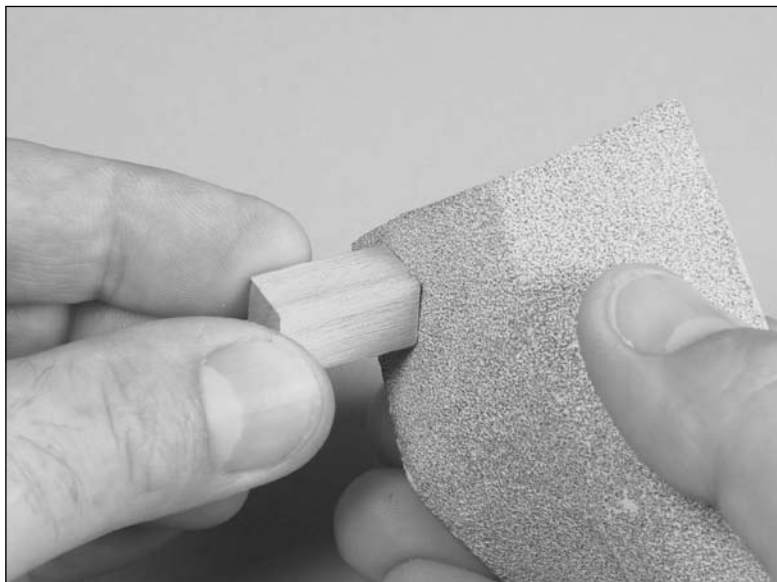

2. Use 6-minute epoxy to secure the servo mounting blocks on the servo hatch. The positions for the blocks have been etched onto the hatch for your convenience.

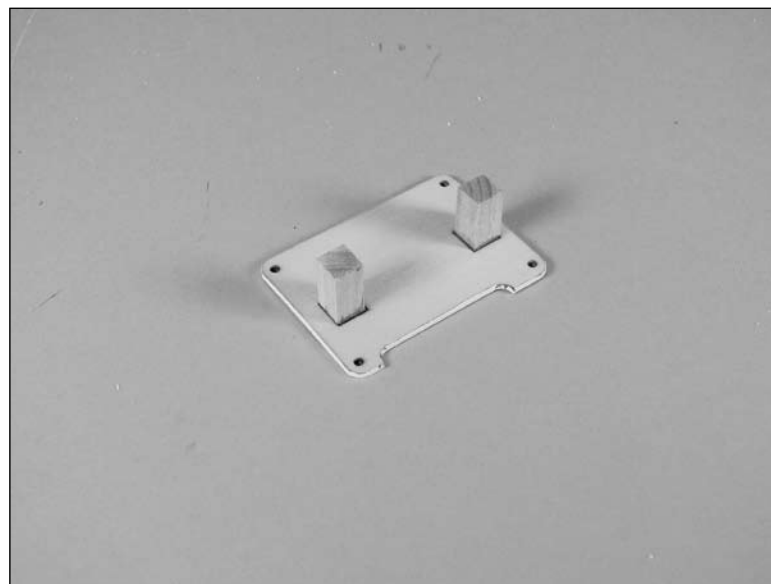
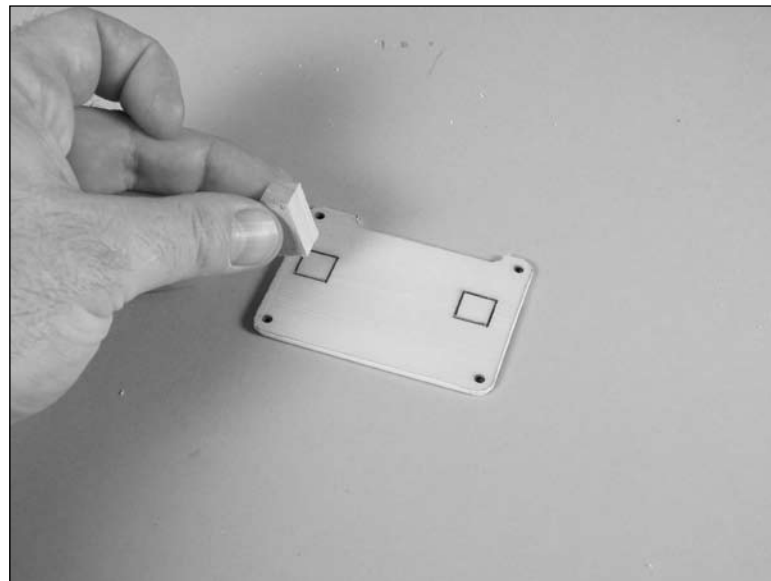

- 3. Position the servo between the blocks. Leave a small gap between the servo and hatch to prevent the transfer of vibration from the airframe into the servo. Use a pencil to transfer the locations for the servo mounting screws onto the servo mounting blocks.

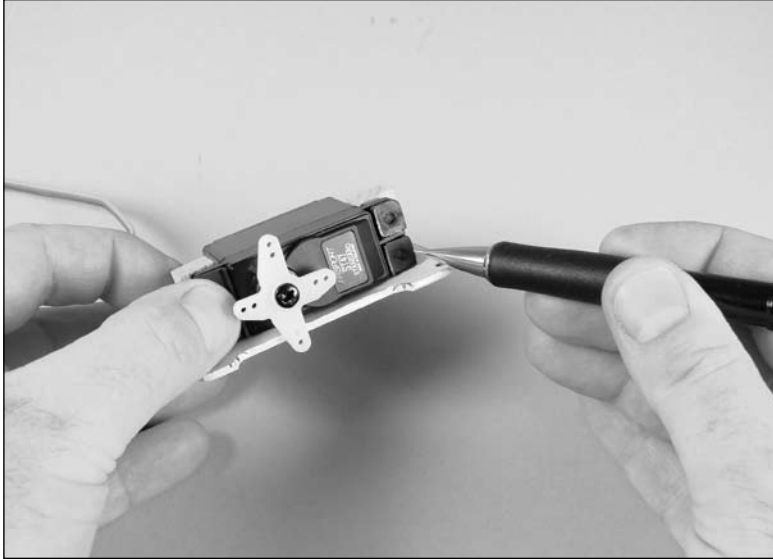

- 4. Use a drill and 1/16-inch (1.5mm) drill bit to drill the four holes for the servo mounting screws.

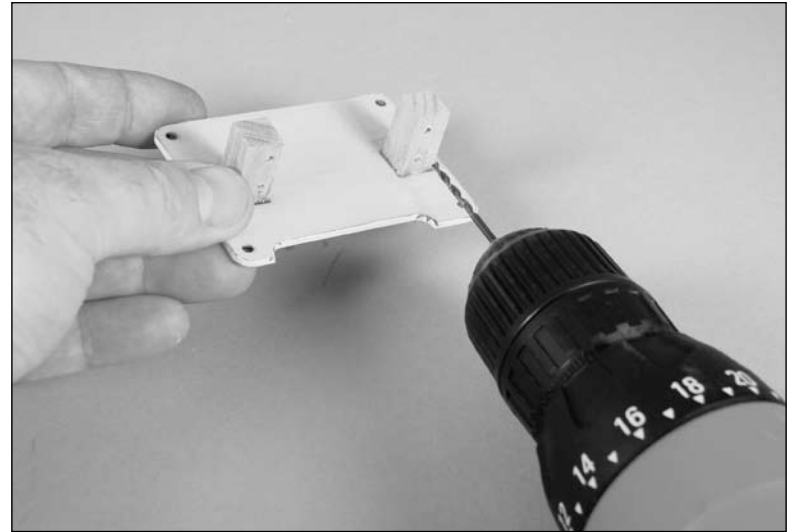

- 5. Apply 2–3 drops of thin CA into the holes to harden the surrounding wood. This provides a hard surface for the screws, making them more secure when installed.

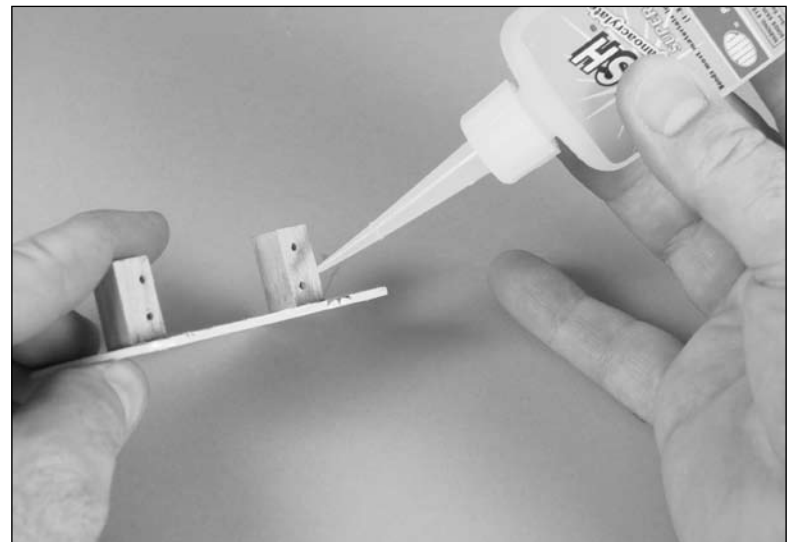

- 6. Attach the servo to the servo mounting blocks using the screws provided with the servo and a #1 Phillips screwdriver.

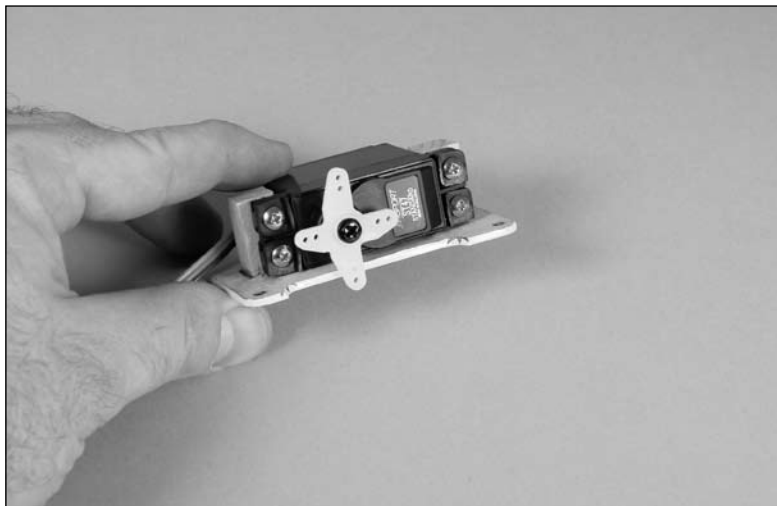

- 7. Remove the servo horn using a #1 Phillips screwdriver and trim away any unused arms from the servo horn with side cutters. Once complete reinstall the servo horn using a #1 Phillips screwdriver. Use a pin drill and 5/64-inch (2mm) drill bit to enlarge to outer hole in the remaining servo arm as shown.

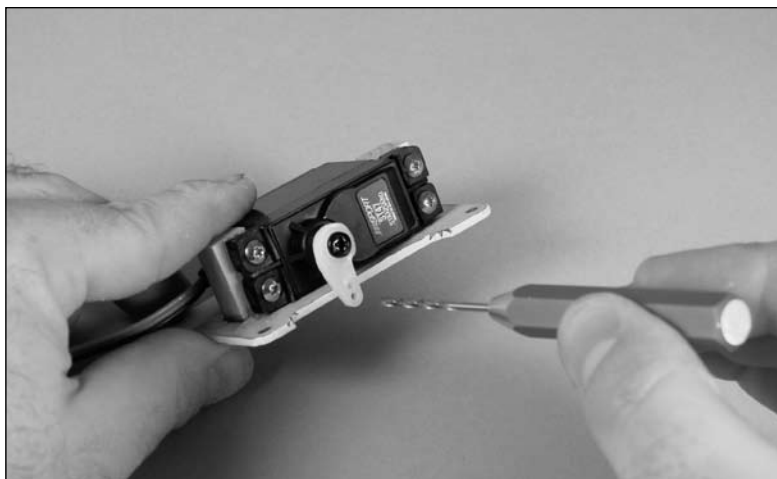

- 8. Tie the string that has been installed in the outer wing panel to the servo lead.

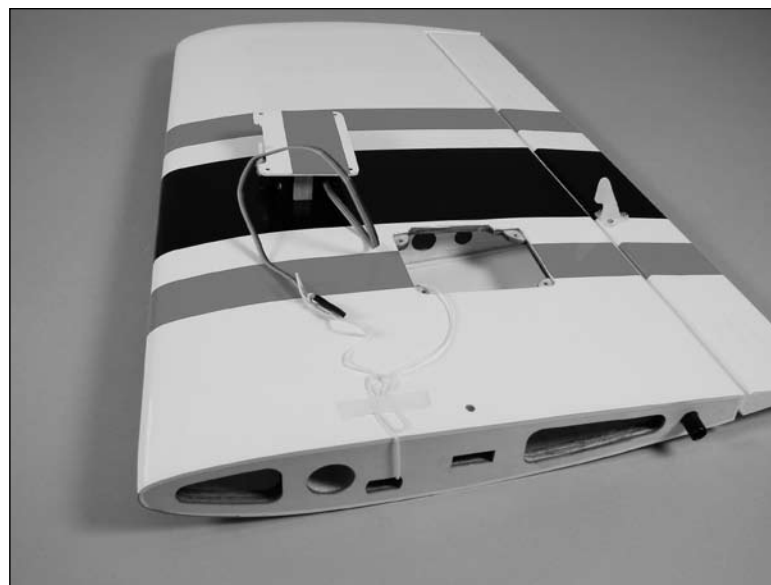

- 9. Use the string to pull the servo lead through the wing panel as shown.

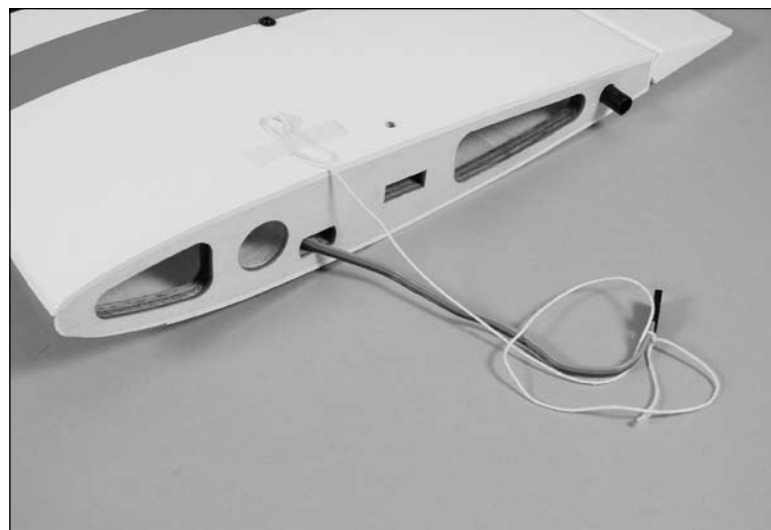

- ○ 10. Secure the servo hatch to the wing using four 2mm x 10mm self tapping screws and a #1 Phillips screwdriver.

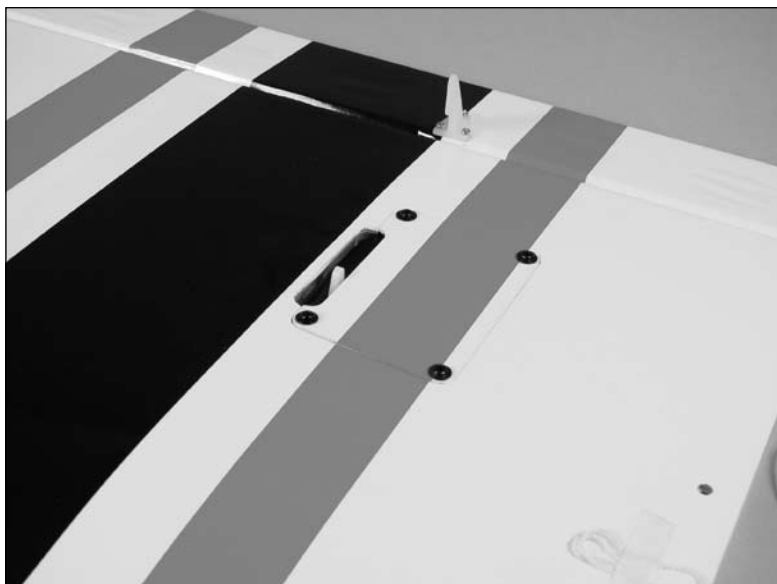

- ○ 11. Slide a silicone clevis retainer onto a nylon clevis. Thread the clevis onto the 4 1/4-inch (108mm) aileron pushrod wire.

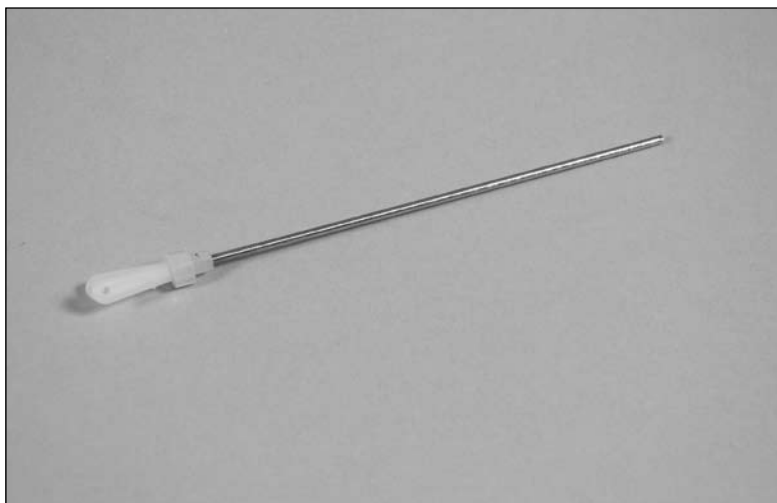

- ○ 12. Attach the clevis to the aileron control horn center hole.

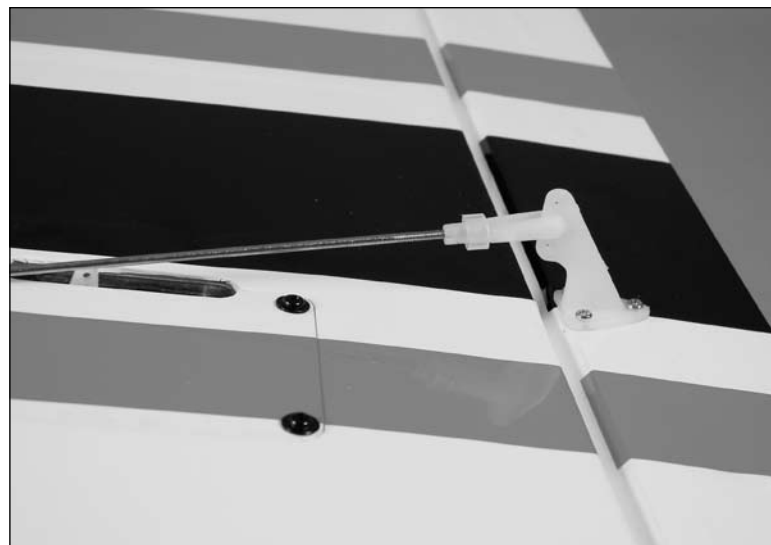

- ○ 13. Use the radio system to center the aileron servo. With the aileron in the center position, use a felt-tipped pen to mark the pushrod where it crosses the hole in the aileron servo arm.

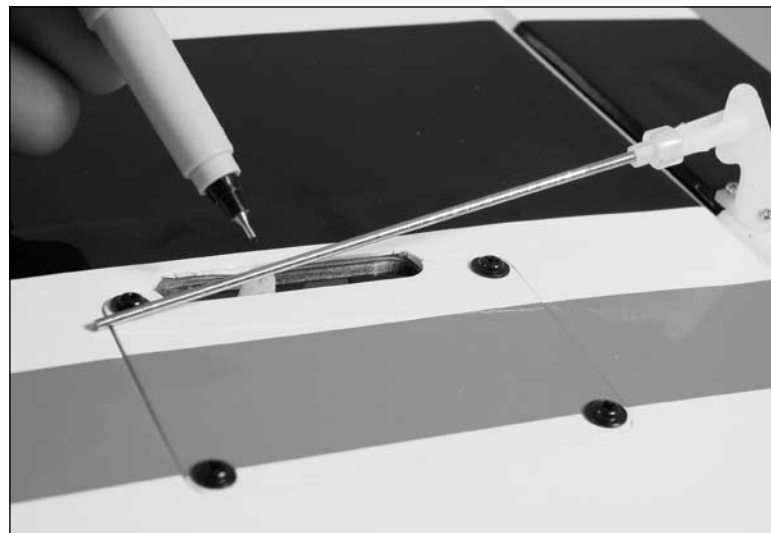

- ○ 14. Use pliers to bend the pushrod 90-degrees at the mark made in the previous step.

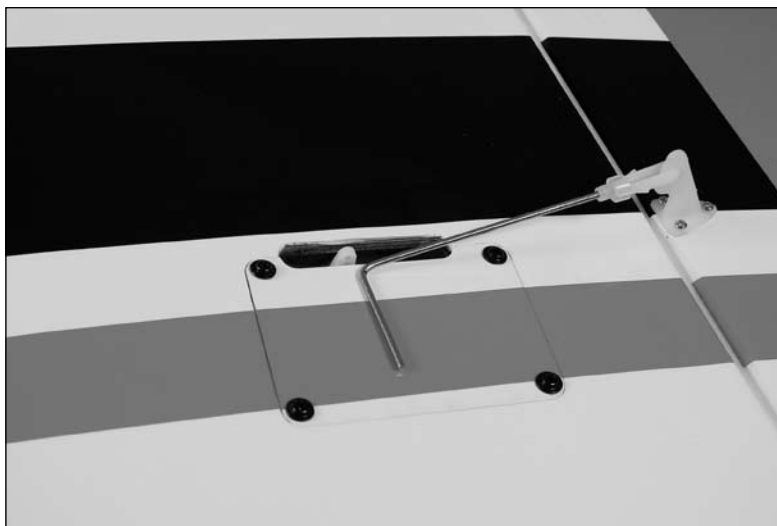

- ○ 15. Slide the pushrod wire into the servo arm.



- ○ 16. Secure the pushrod wire to the servo horn using a nylon pushrod keeper. Use side cutters to remove any excess pushrod wire that would interfere with the operation of the aileron.



- 17. Repeat Steps 2 through 16 to install the remaining aileron servo and linkage.

Flap Servo Installation

Required Parts

Wing center section	Servo w/hardware
Brass pushrod connector	Nylon connector backplate
Flap linkage	Nylon clevis (2)
Silicone clevis retainer (2)	3mm x 5mm machine screw
Nylon control horn (2)	

Required Tools and Adhesives

Felt-tipped pen	Pin drill
Thin CA	Side cutter
Phillips screwdriver: #1	Pliers
Threadlock	
Drill bit: 1/16-inch (1.5mm), 5/64-inch (2mm)	

- 1. Position the flap servo into the wing. Use a felt-tipped pen to transfer the locations for the servo mounting screws onto the wing.

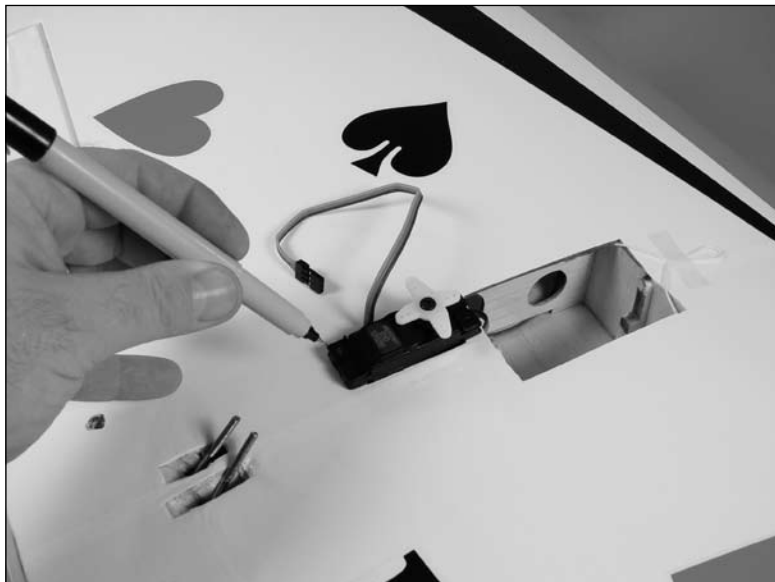

- 2. Use a pin drill and 1/16-inch (1.5mm) drill bit to drill the holes to mount the flap servo.

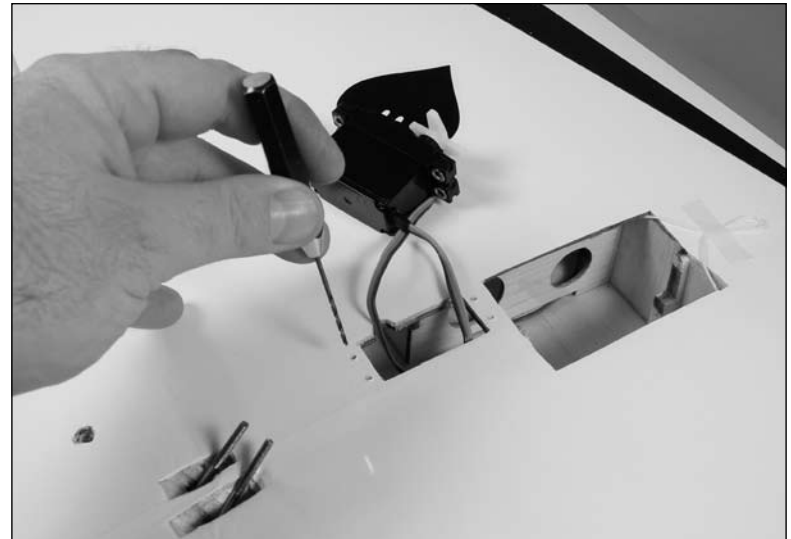

- 3. Apply 2–3 drops of thin CA into each of the four holes. This will harden the surrounding wood to provide a hard surface for the screws to bite into so they will be more secure when installed.



- 4. Secure the flap servo in the wing using a #1 Phillips screwdriver and the hardware provided with the servo.



- 5. Thread the nylon control horns onto the flap torque rods until they are flush on top. Make sure they are positioned equally or the flaps will not have the same amount of throw.

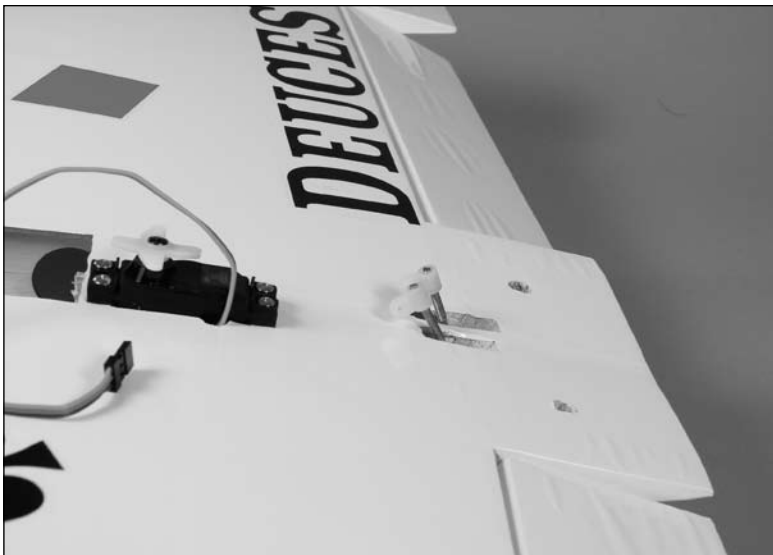

- 6. Remove the flap servo horn from the flap servo. Use a pin drill and 5/64-inch (2mm) drill bit to enlarge to outer hole of the flap servo horn.

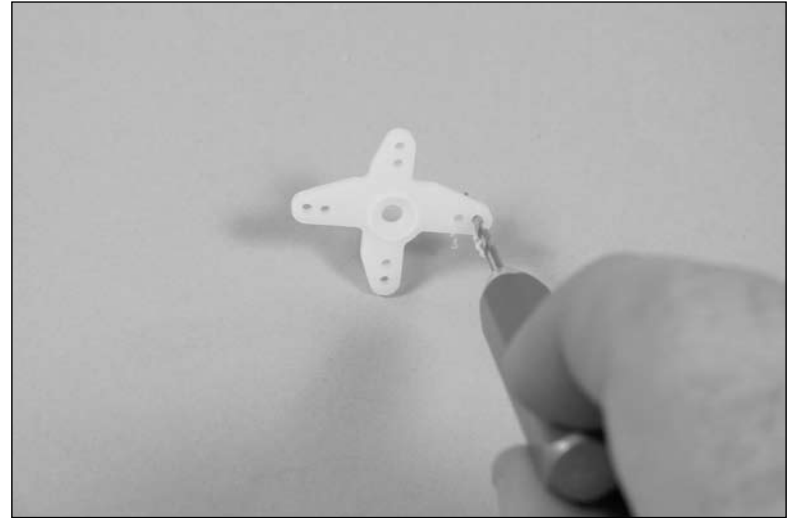

- 7. Slide the brass pushrod connector in the hole drilled in the previous step.



- 8. Secure the connector using a nylon connector backplate. You may trim the servo horn with side cutters to remove the unused arms if you choose.

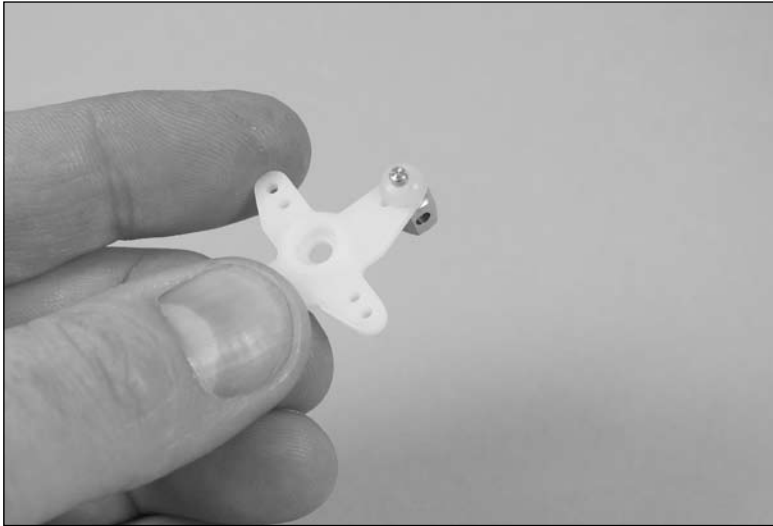

- 9. Install the servo horn on the flap servo. The horn is shown installed in the up flap position.



- 10. Slide a silicone clevis retainer onto each of the two clevises required for the flap linkage. Thread the clevises onto the flap linkage.

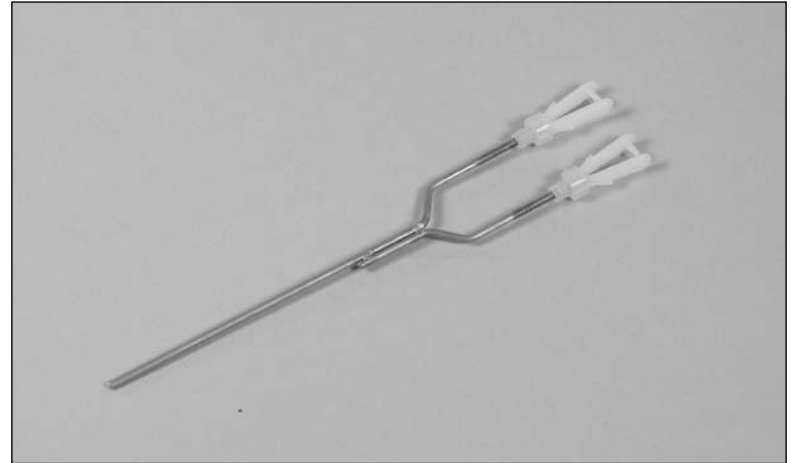

- 11. Attach the clevises to the flap control horns. The wire will then slide into the brass pushrod connector on the servo. You may need to use pliers to make a slight bend in the linkage so it will not bind when the flaps are in operation.



- 12. Make sure the flap servo is in the up position using the radio system. Move the flaps to the up position and use a 3mm x 5mm machine screw to secure the flap linkage in the connector. Use threadlock on the screw to prevent it from vibrating loose.

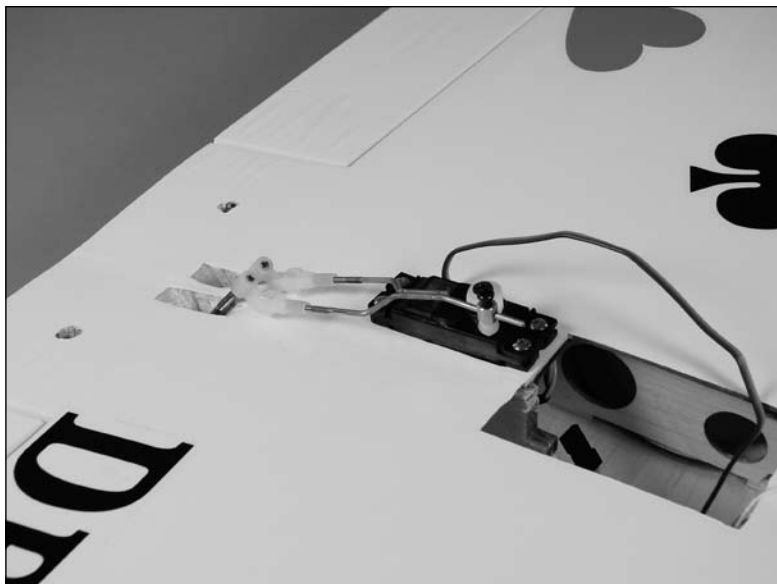

- 13. The following images show the three positions of the flaps and the position of the servo in correlation to these positions.

Flap Up:

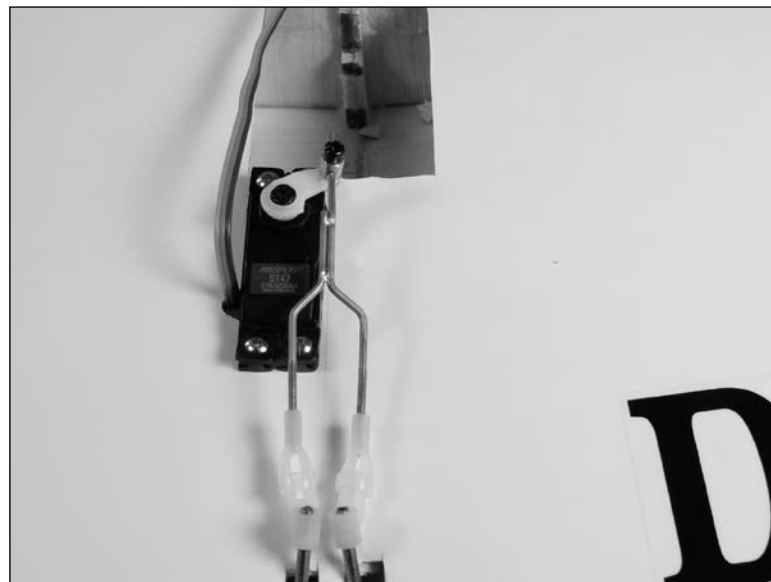

Half Flap:

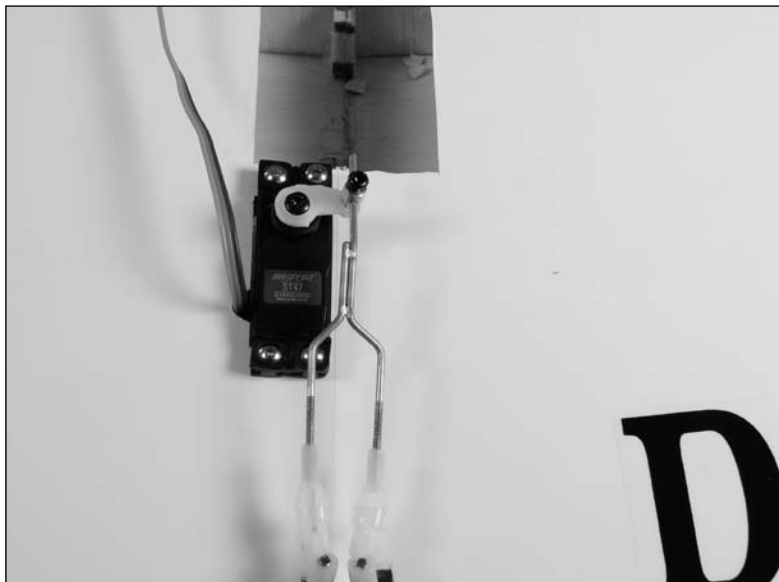

Full Flap:

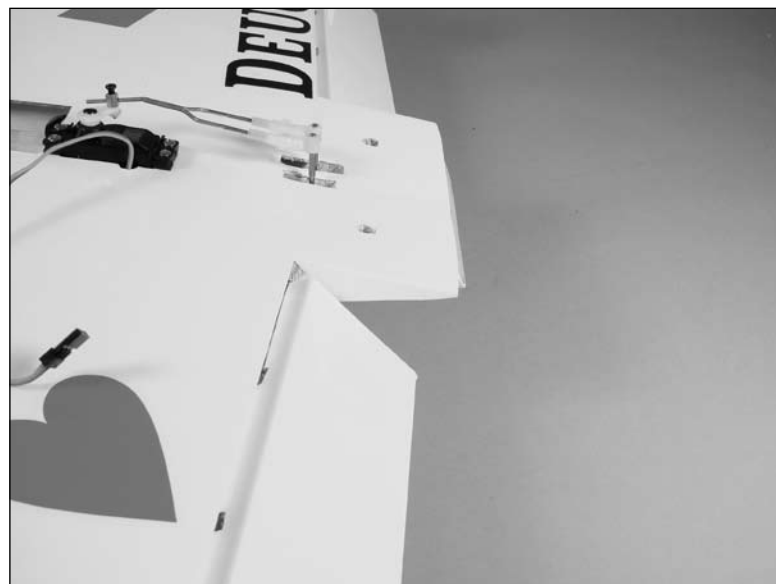
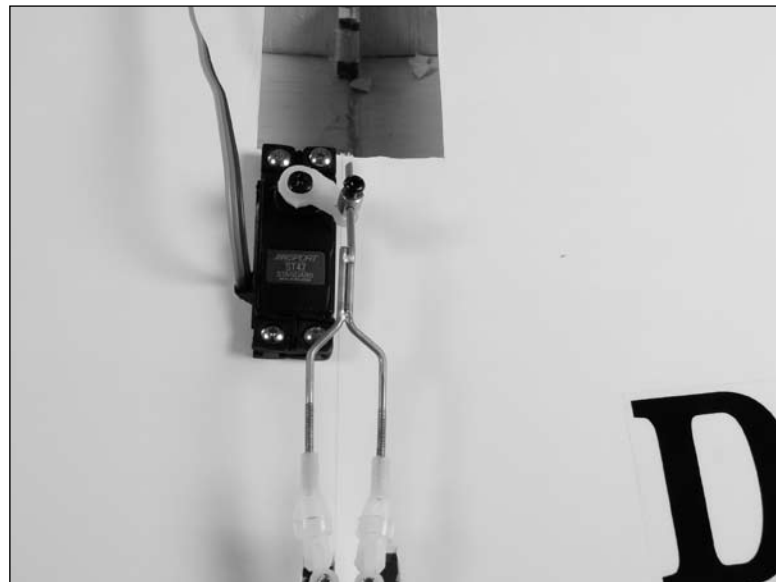

Fixed Gear Installation

Required Parts

Wing center section	Fuselage assembly
Main gear (right and left)	Nose gear
Nylon clevis	Brass pushrod connector
Silicone clevis retainer	3mm x 5mm machine screw
Nylon connector backplate	
29 3/4-inch (755mm) pushrod wire	
3mm x 8mm self-tapping countersink screw (12)	

Required Tools and Adhesives

Pencil	Phillips screwdriver: #1, #2
Drill	Pin drill
Thin CA	Side cutter
Threadlock	Sandpaper
Drill bit: 5/64-inch (2mm), 3/32-inch (2.5mm)	

Note: There is a left and right main gear unit. Please note that the coil on the wire should be to the aft side and the wheel towards the center of the wing.

1. Position the main landing gear in the opening in the wing. Use a pencil to transfer the locations for the mounting screws on to the landing gear rails. Please ensure you center the main landing gear unit on the mounting rails.

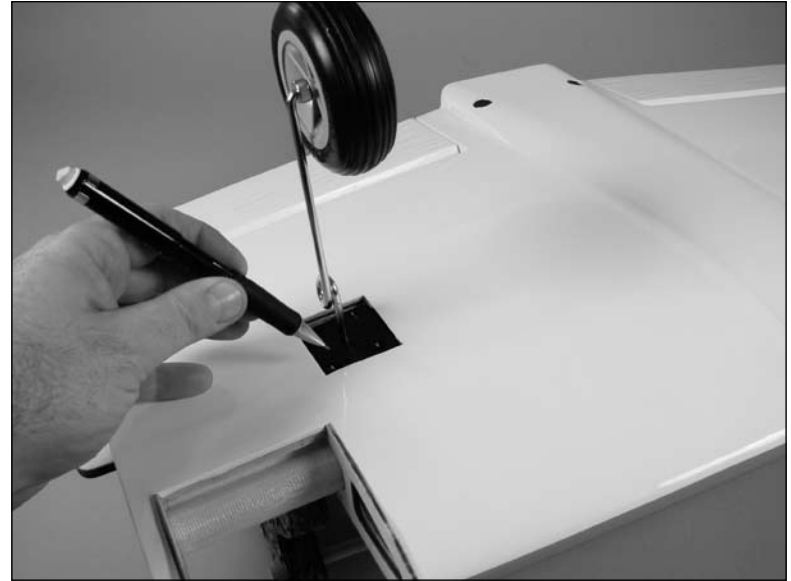

Note: Due to the model being designed for retracts and fixed gear, you might need to slightly sand the flashing off the edges of the fixed gear mounts to ensure an interference free fit in the wing.

- 2. Use a drill and 3/32-inch (2.5mm) drill bit to drill the locations for the four screws.



- 3. Apply 2–3 drops of thin CA into each of the holes. This will harden the surrounding wood and provide a harder surface for the screws, helping prevent them from pulling loose on a hard landing.



- 4. Secure the main gear in the wing center section using a #2 Phillips screwdriver and four 3mm x 8mm self-tapping countersink screws.

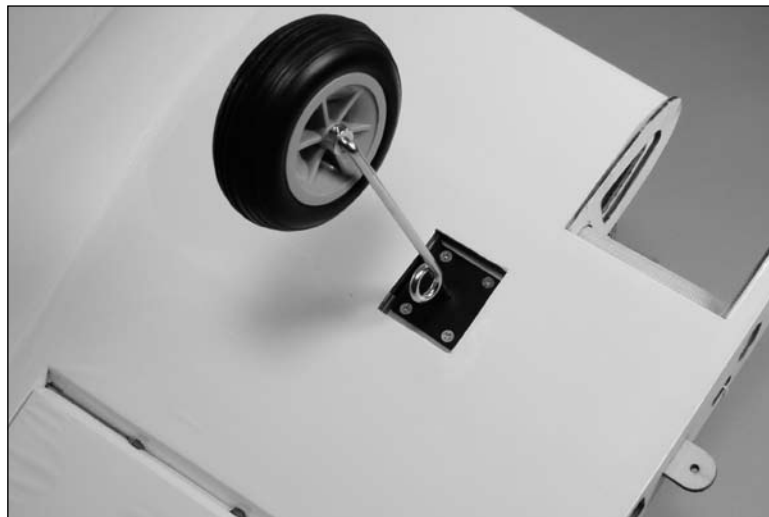

- 5. Repeat Steps 1 through 4 to install the remaining main landing gear.

- 6. Position the nose landing gear in the opening in the fuselage. Use a pencil to transfer the locations for the mounting screws on the landing gear rails. Locate the nose gear unit as far forward as possible while still being able to rotate the nose gear strut wire.

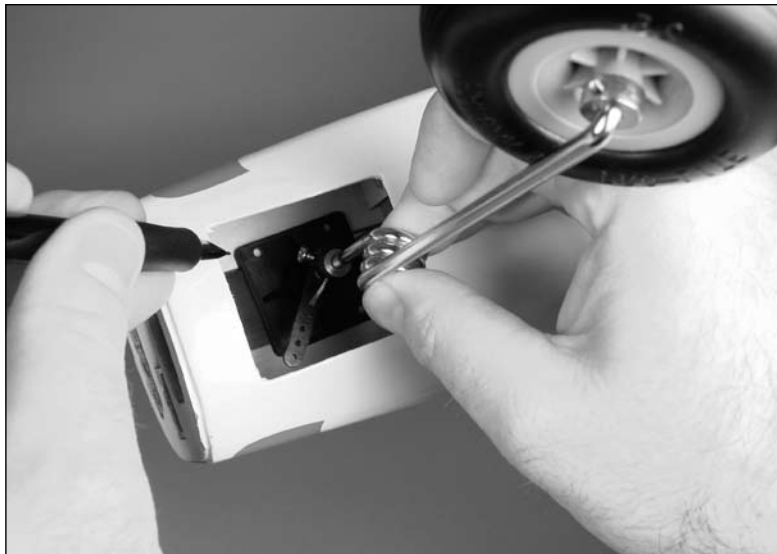

- 7. Use a drill and 3/32-inch (2.5mm) drill bit to drill the locations for the four screws.

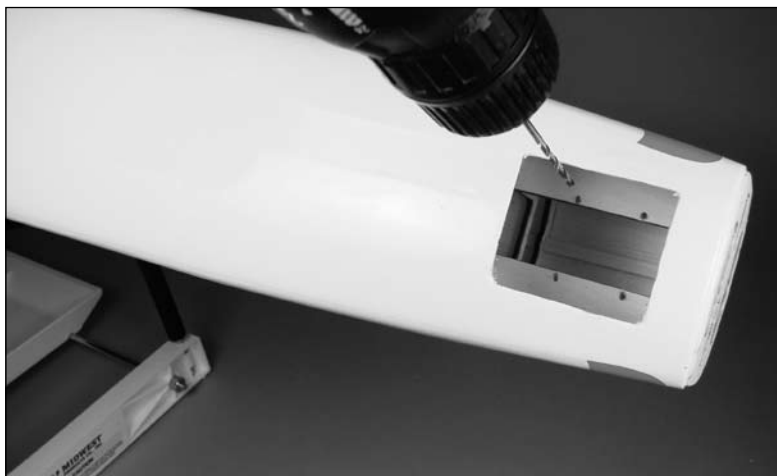

- 8. Apply 2–3 drops of thin CA into each of the holes. This will harden the surrounding wood and provide a harder surface for the screws, helping prevent them from pulling loose on a hard landing.

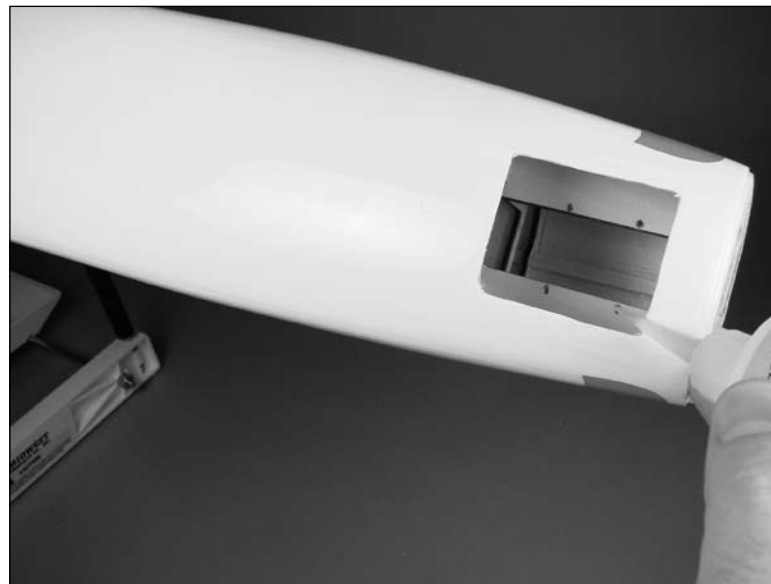

- 9. Thread a clevis onto the 29³/₄-inch (755mm) pushrod wire. Make sure to slide a silicone clevis retainer onto the clevis before threading it onto the pushrod wire.

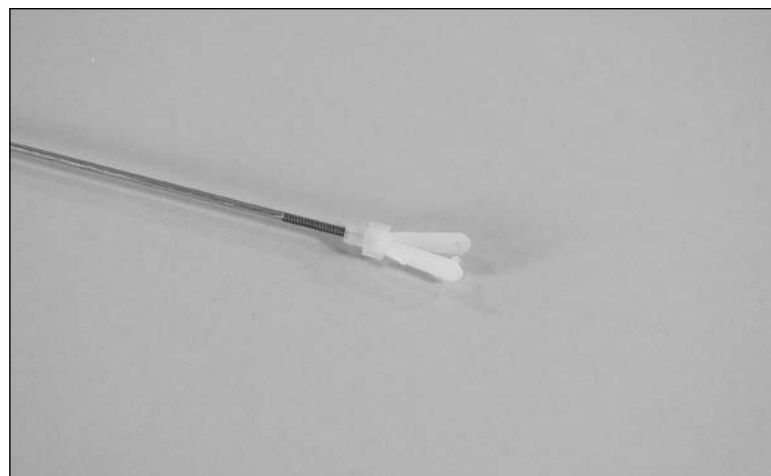

- 10. Connect the clevis to the center hole of the nose wheel steering arm.

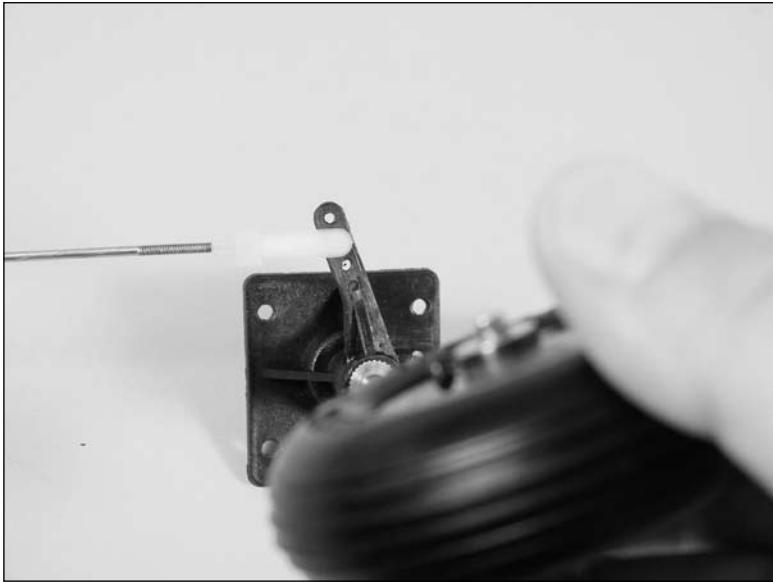

- 11. Slide the pushrod wire into the tube installed in the front of the fuselage.



- 12. Secure the nose gear in the fuselage using a #2 Phillips screwdriver and four 3mm x 8mm self-tapping countersink screws.



- 13. Use a #1 Phillips screwdriver to remove the nose gear steering servo horn from the steering servo. Use a pin drill and 5/64-inch (2mm) drill bit to enlarge the outer hole of the steering servo horn.

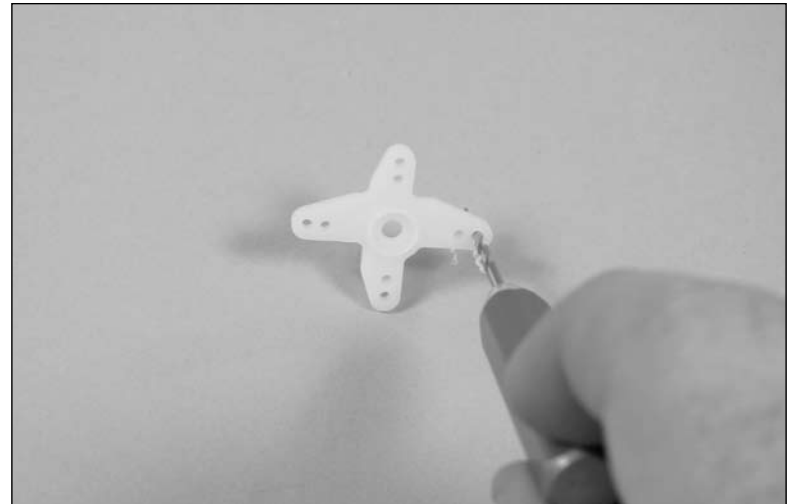

- 14. Slide the brass pushrod connector in the hole drilled in the previous step.



- 15. Secure the connector to the servo horn using a nylon connector backplate.

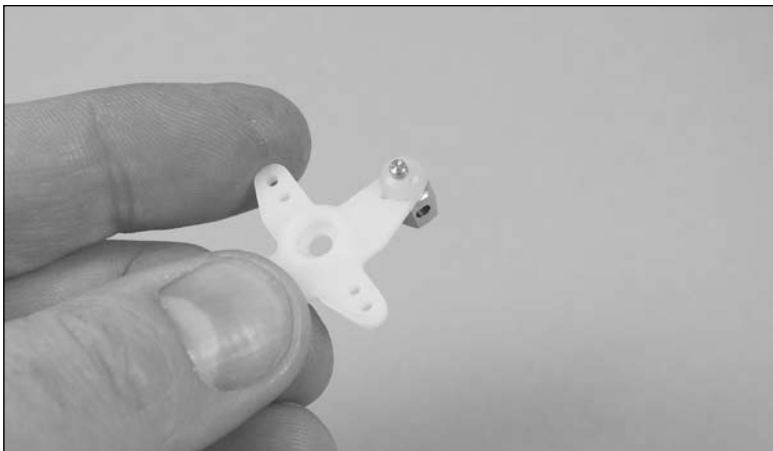

- 16. Use the radio system to center the steering servo. Slide the brass connector onto the wire then secure it to the steering servo. After centering the nose wheel, use a 3mm x 5mm machine screw to secure the pushrod wire to the connector. Use threadlock on the machine screw to ensure it will not vibrate loose during flight. You may wish to trim the unused arms from the servo horn with a pair of side cutters to ensure nothing interferes with servo operation. Now check to ensure the nose wheel turns left when you apply left rudder.



Note: If you need to adjust the steering so your model tracks straight on the runway, use this screw to do so. Use the rudder trim at the radio to correct for rudder trim in the air only. You may wish to trim the pushrod wire with side cutters once you have finalized the setting and nose wheel steering adjustment.

Retract Gear Installation

Required Parts

Wing center section	Fuselage assembly
Nose gear retract	Main gear retract (right and left)
Brass pushrod connector (2)	Quick disconnect (male and female)
Nylon connector backplate (2)	Air line
Steering cable	Cable crimp (4)
Cable fitting (2)	2mm x 8mm machine screw (2)
Air tank	Air fill fitting
Air line	T-fitting
3/16 inch wheel collars (4) (not included)	
3mm x 8mm self-tapping countersink screw (12)	

Required Tools and Adhesives

Hobby knife w/#11 blade	Covering iron
Pencil	Drill
Thin CA	Pin drill
Phillips screwdriver: #1, #2	Side cutters
Pliers	Silicone adhesive
Threadlock	
Drill bit: 5/64-inch (2mm), 3/32-inch (2.5mm), 3/16-inch (5mm)	

Note: The retracts for your Deuces Wild have been designed to drop directly into the model with no modifications. The wheel openings for the nose gear should be very close to correct. If the nose gear hangs up on the fuselage bottom once installed, you only need to trim the balsa slightly to allow an interference-free operation during retraction and extension. Use of other retract systems may require modification to the airframe which will have to be accomplished by the modeler. You will note your retract wire struts are slightly different from the ones shown in the manual. We did not have production units available at the time of writing the manual and needed to cut our wire to the correct length. Your wires struts are pre-bent to the correct length and have been sized for the Deuces Wild.

1. Use a hobby knife and #11 blade to trim the covering to expose the opening for the nose gear retract. Trim the covering leaving 1/8-inch (3mm) overlap of covering from the inside edge of the opening so it can be ironed down to add a clean finish to your model.



2. Use a covering iron to iron the covering inside the edges of the retract opening.



- 3. Position the nose landing gear in the opening in the fuselage. Use a pencil to transfer the locations for the mounting screws on the landing gear rails. Position the unit as far forward as you can while still allowing the nose gear to steer left and right.



- 4. Use a drill and 3/32-inch (2.5mm) drill bit to drill the locations for the four screws.



- 5. Apply 2–3 drops of thin CA into each of the holes. This will harden the surrounding wood and provide a harder surface for the screws, helping prevent them from pulling loose.

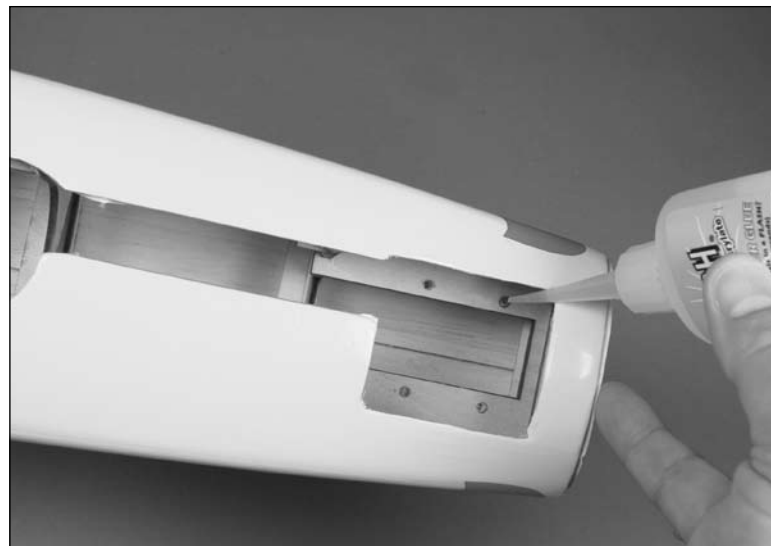

- 6. Cut a 10-inch (254mm) piece of air line. Attach the air line to the fitting on the nose gear retract.



- 7. Locate the steering cable and two crimps. Use side cutters to cut the cable into two equal lengths. Slide a crimp onto the cable, then pass the cable through the outside hole of the nose gear steering arm. Slide the cable back through the crimp and compress the crimp with pliers to secure the cable. Attach a cable to both sides of the steering arm at the outer most hole.

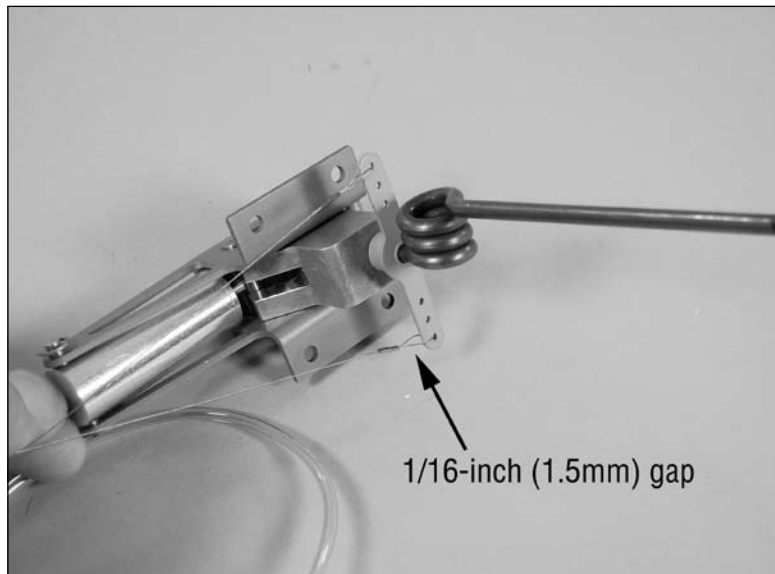

Note: You do not want any more than a 1/16-inch (1.5mm) gap between the crimp and the aft portion of the steering arm.

- 8. Slide the steering cables into the pre-installed tubes in the fuselage.

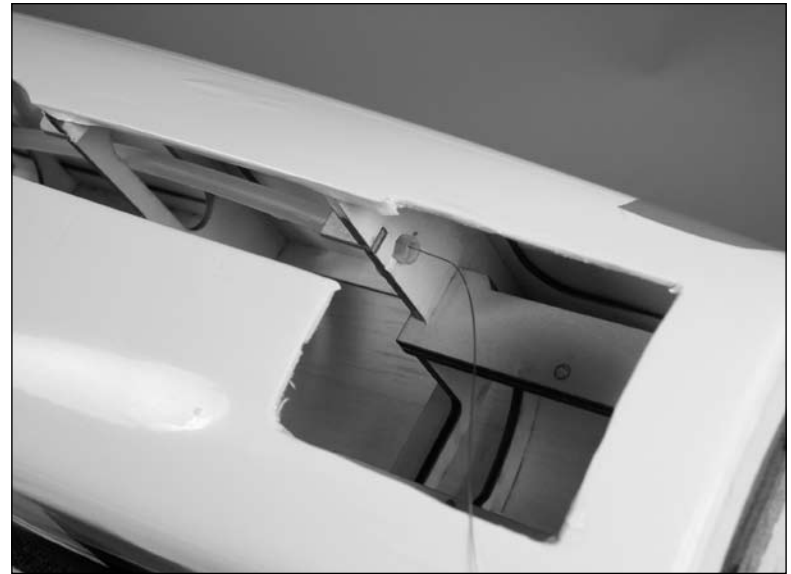

- 9. Secure the nose gear in the fuselage using a #2 Phillips screwdriver and four 3mm x 8mm self-tapping countersink screws.



- 10. Remove the wheel from the fixed nose gear using a #2 Phillips screwdriver to loosen the screw that secures the wheel collar. Slide the wheel collar without the screw onto the nose gear wire, then the nose wheel. Use the wheel collar from the fixed gear to secure the wheel on the retract strut. A #2 Phillips screwdriver and threadlock is used to tighten the screw that secures the collar to the axle.

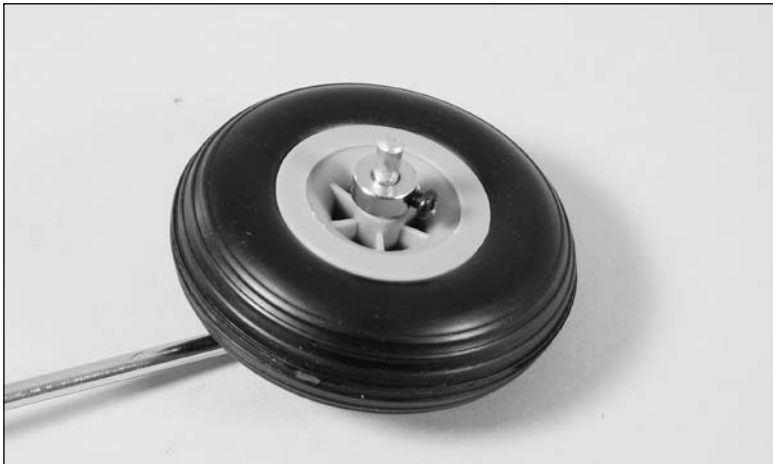

Note: The wheel is shown on the building surface for clarity and contrast.

- 11. Remove the nose gear steering servo horn from the steering servo. Use a pin drill and 5/64-inch (2mm) drill bit to enlarge the outer holes of the steering servo horn.

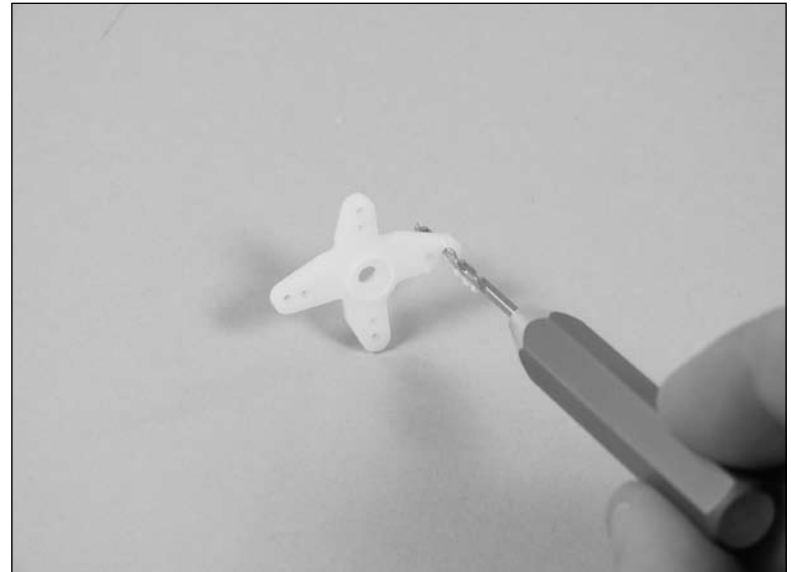

- 12. Slide the two brass pushrod connectors in the holes drilled in the previous step.



- 13. Secure the connectors to the servo horn using a nylon connector backplates.

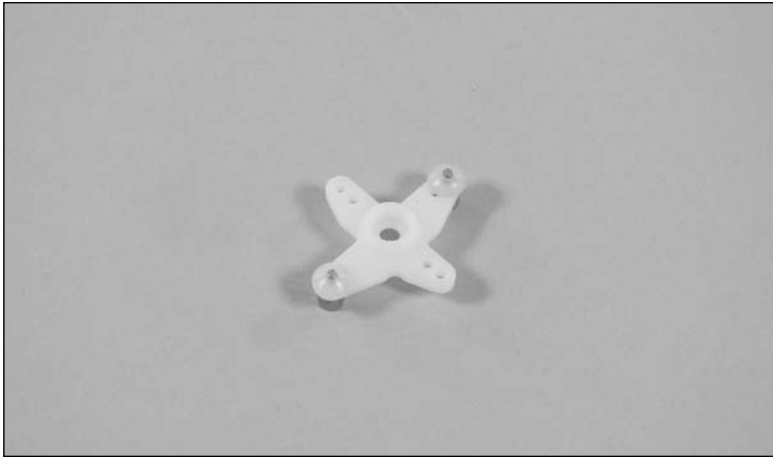

- 14. Center the steering servo using the radio and secure the steering servo arm to the steering servo. Slide the cable fittings into the pushrod connectors and temporarily secure them using two 2mm x 8mm machine screws and a #1 Phillips screwdriver. Ensure you set the cable fittings so they are equal to each other when installed.

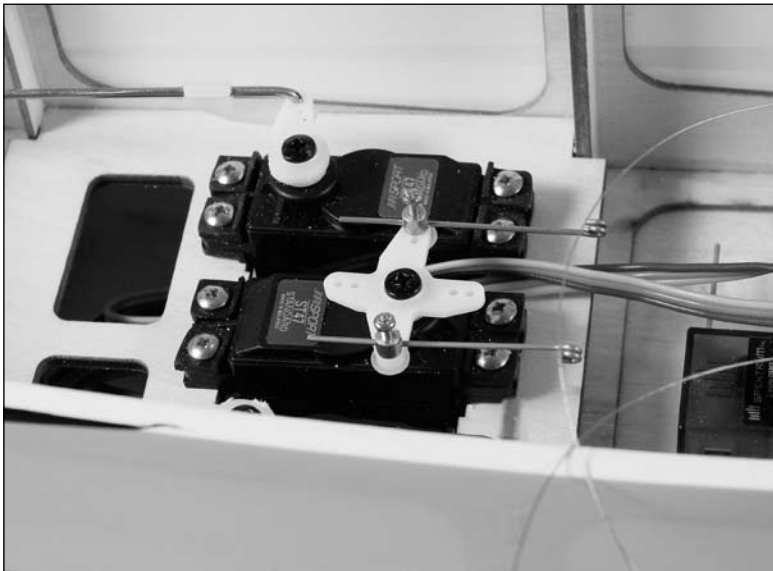

- 15. Slide a crimp onto the steering cable, then pass the cable through the cable fittings. The cable will then go through the crimp. Prepare both cables before crimping the connectors. This will allow you to tensions the cables lightly and center the nose gear before compressing the crimps. Use side cutters to trim any excess cable.



Note: You do not want the steering cables to be real tight. This will cause your nose gear to not lock down during extension. There should be a small amount of play in the steering cables (approximately 1 degree left and right on the nose wheel) to ensure correct operation.

- 16. Cut a 3-inch (76mm) piece of air line and attach it to the air fill fitting.



- 17. Use a hobby knife to remove the covering from the fuselage to expose the pre-drilled hole for the air fill fitting.



- 18. Use the hardware supplied to secure the fitting in the fuselage.



- 19. Cut a 3-inch (76mm) piece of air line and attach it to the air tank.



- 20. Use silicone adhesive to secure the air tank in the fuselage. The air line between the air fill fitting and air tank are connected using a T-fitting. Cut and attach a 3-inch (76mm) piece of air line to the fitting. Attach a female quick disconnect to the 3-inch line coming from the T-fitting and the retract air line. Attach a male quick disconnect to the 3-inch (76mm) line coming from the T-fitting and air tank air line.



Note: The air tank shown in the photos is not of the correct size. The correct size air tank is included with your retract package.

- 21. Use a hobby knife and #11 blade to trim the covering to expose the opening for the main gear retract. Trim the covering for the wheel well making a 1/8-inch (3mm) overlap of covering from the inside edge of the opening so it can be ironed down to add a clean finish to your model.

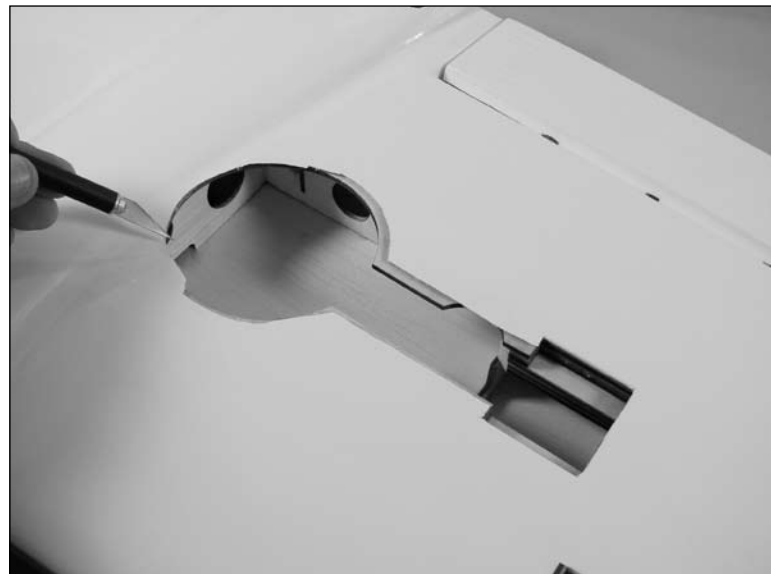

- ○ 22. Use a covering iron to iron the covering inside the edges of the retract opening.



- ○ 23. Position the main landing gear in the opening in the wing. Use a pencil to transfer the locations for the mounting screws on to the landing gear rails.

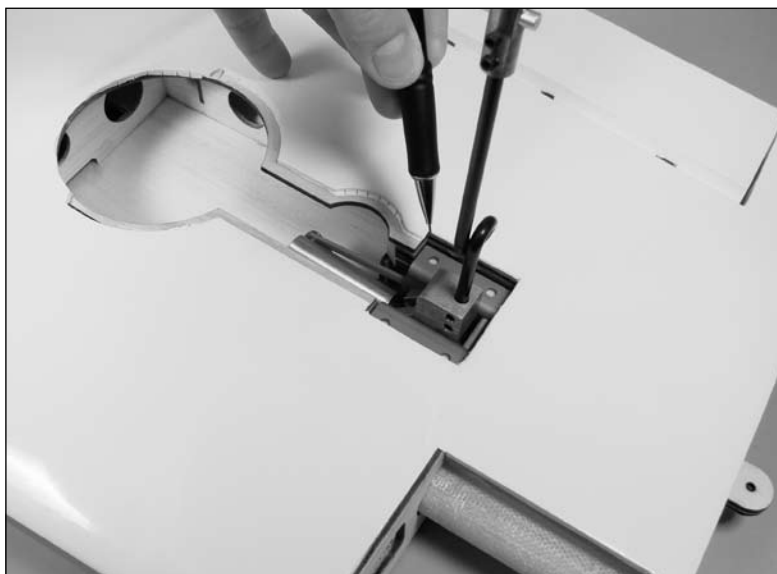

- ○ 24. Use a drill and 3/32-inch (2.5mm) drill bit to drill the locations for the four screws.

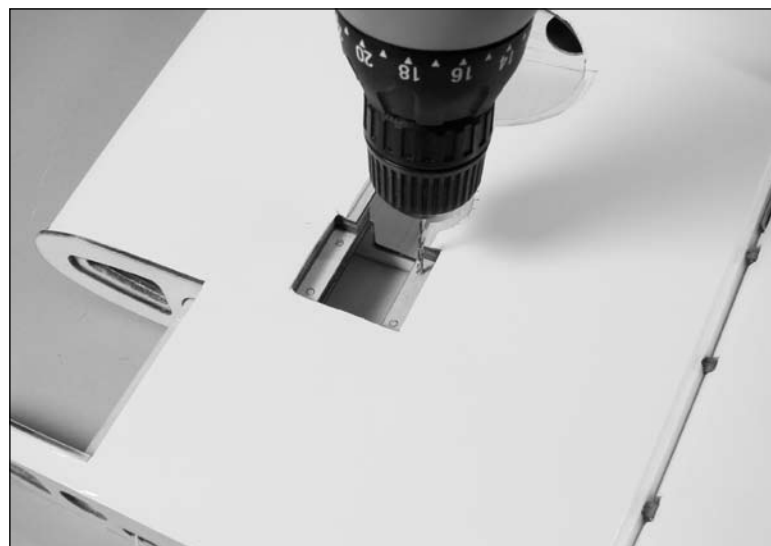

- ○ 25. Apply 2–3 drops of thin CA into each of the holes. This will harden the surrounding wood and provide a harder surface for the screws, helping prevent them from pulling loose.



- 26. Cut a 10-inch (254mm) piece of air line. Attach the air line to the fitting on the main gear retract.

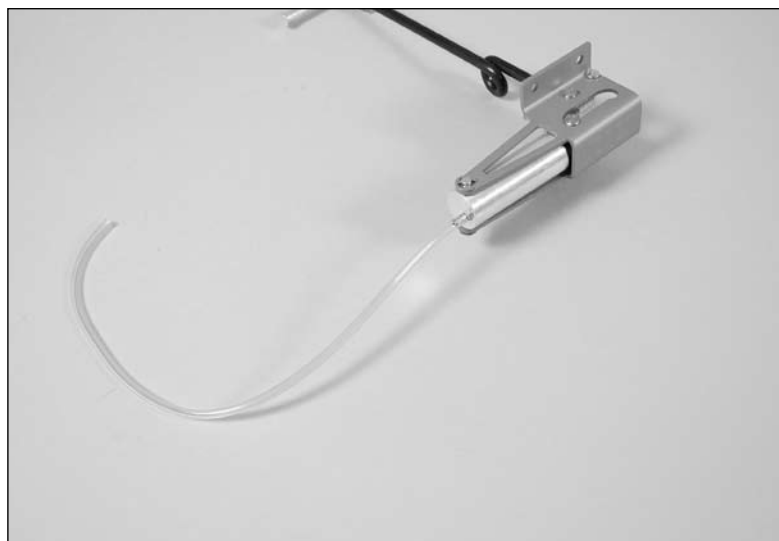

- 27. Secure the main gear in the wing center section using a #2 Phillips screwdriver and four 3mm x 8mm self-tapping countersink screws.



- 28. Remove the wheel from the fixed main gear using a #2 Phillips screwdriver to loosen the screw that secures the wheel collar. Use a drill and 3/16-inch (5mm) drill bit to enlarge the hole in the main wheel.



- ○ 29. Slide a 3/16-inch wheel collar without a screw onto the main gear wire, then the wheel. Use a 3/16-inch wheel collar to secure the wheel on the retract strut. A #2 Phillips screwdriver is used to tighten the screw that secures the collar to the axle.

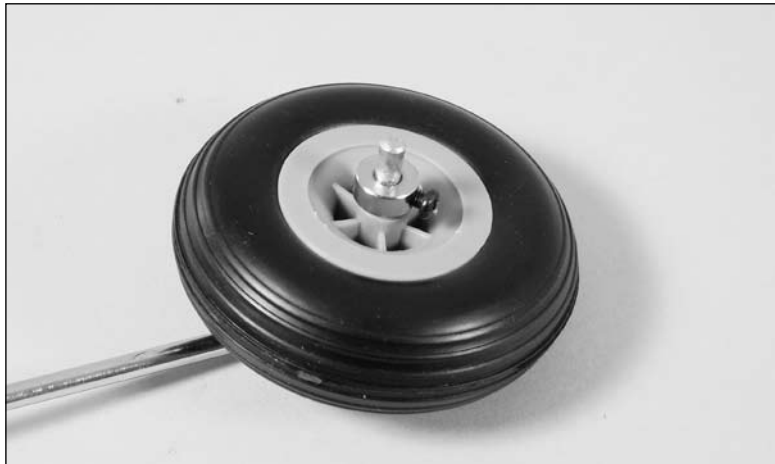

Note: The wheel is shown on the building surface for clarity and contrast.

- 30. Repeat Steps 21 through 29 to install the remaining main gear retract.

Retract Servo Installation

Required Parts

Wing center section	Actuator valve
Plywood valve mount	Nylon clevis
Clevis retainer	3-inch (76mm) pushrod
Air line	Air line T-fitting (2)
Brass pushrod connector	Connector backplate
Tie wrap (4)	Servo w/hardware
3mm x 5mm machine screw	Plywood servo tray
Quick disconnect (male and female)	

Required Tools and Adhesives

Scissors	Pencil
Pin drill	Side cutters
Mixing cups	Mixing sticks
6-minute epoxy	Medium CA
Thin CA	Phillips screwdriver: #1
Low-tack masking tape	Threadlock
Drill bit: 1/16-inch (1.5mm), 5/64-inch (2mm)	

- 1. Use 6-minute epoxy to secure the retract servo tray in the wing as shown.



Hint: Cut the string routed through the wing into two pieces and tape them to the wing as shown to keep them out of the way during the retract servo install.

- 2. Position the retract servo in the wing. Use a pencil to transfer the locations for the servo mounting screws to the servo tray.

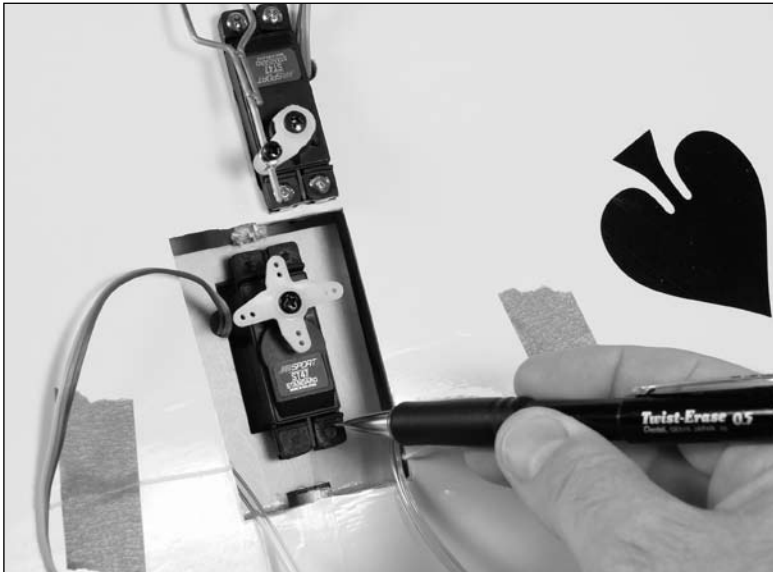

- 3. Use a pin drill and 1/16-inch (1.5mm) drill bit to drill the four holes for the servo mounting screws.



- 4. Apply 2–3 drops of thin CA into each of the holes to harden the surrounding wood. This will provide a harder surface for the screws to bite into when installed.

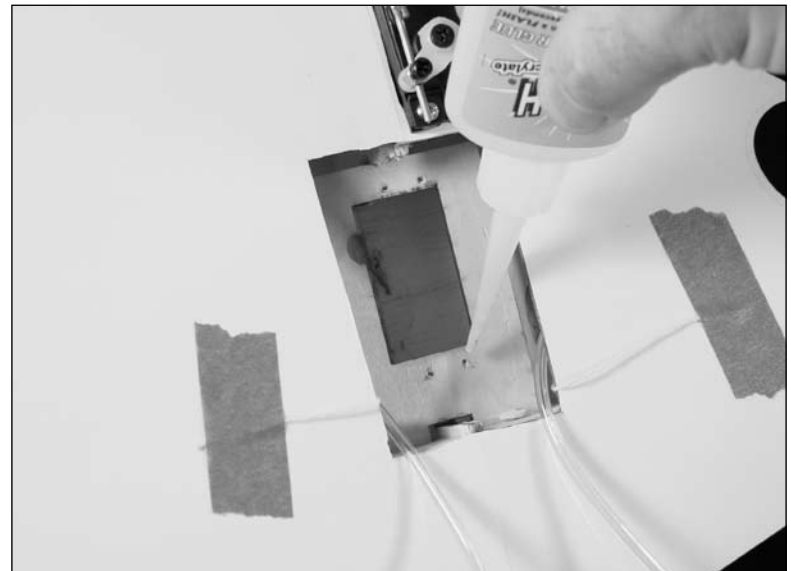

- 5. Secure the retract servo in the wing using the hardware provided with the servo and a #1 Phillips screwdriver. The servo is installed with the output shaft and horn towards the trailing edge of the wing.

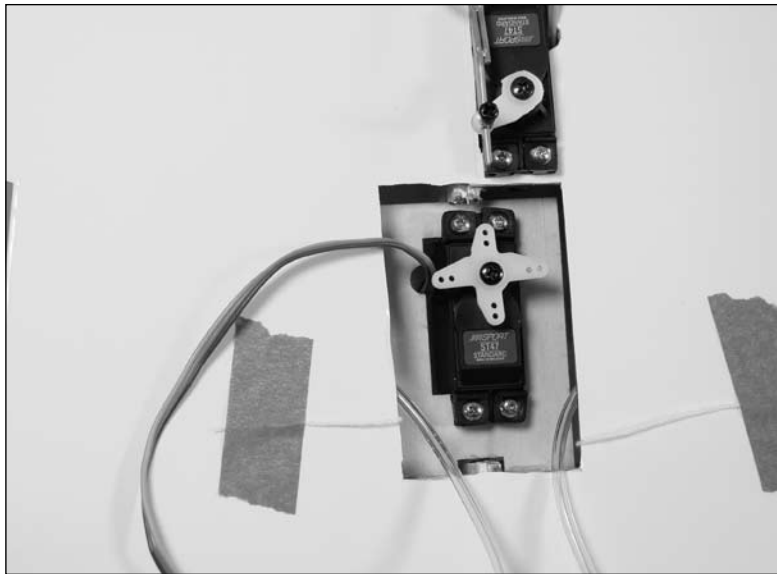

- 6. Attach the actuator valve to the plywood valve mount using the hardware provided with the valve.



- 7. Use medium CA to attach the valve mount as shown.

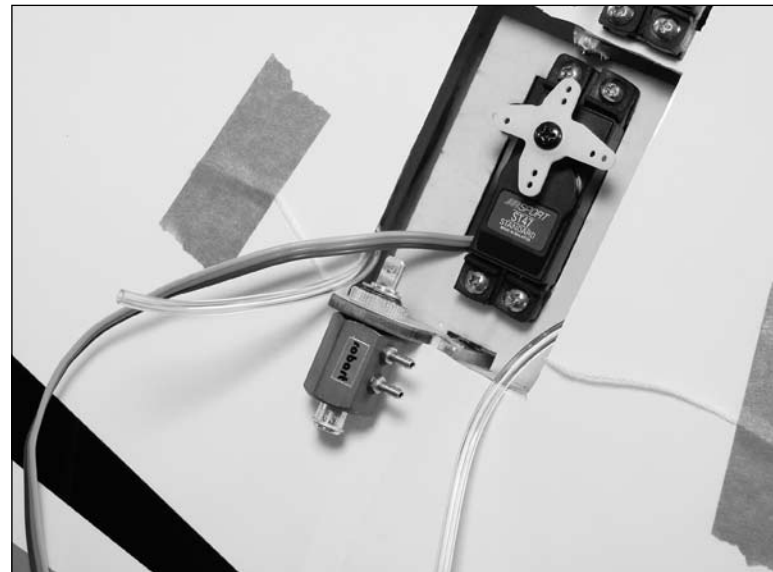

- 8. Use a T-fitting to connect the air lines from the main gear. Attach a 3-inch (76mm) piece of air line to the T-fitting. Use either side cutters or scissors to cut the air line.

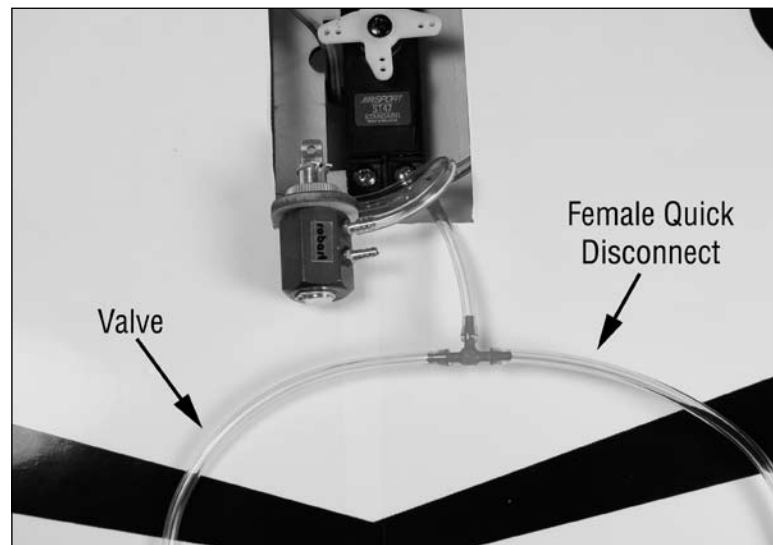

- 9. Attach a T-fitting to the air line from the previous step. On one side of the T-fitting, attach a 3-inch (76mm) section of air line to the actuator valve. On the other side, connect a 6-inch (152mm) section of air line, then a male quick disconnect that mates to the female disconnect on the nose gear retract line.

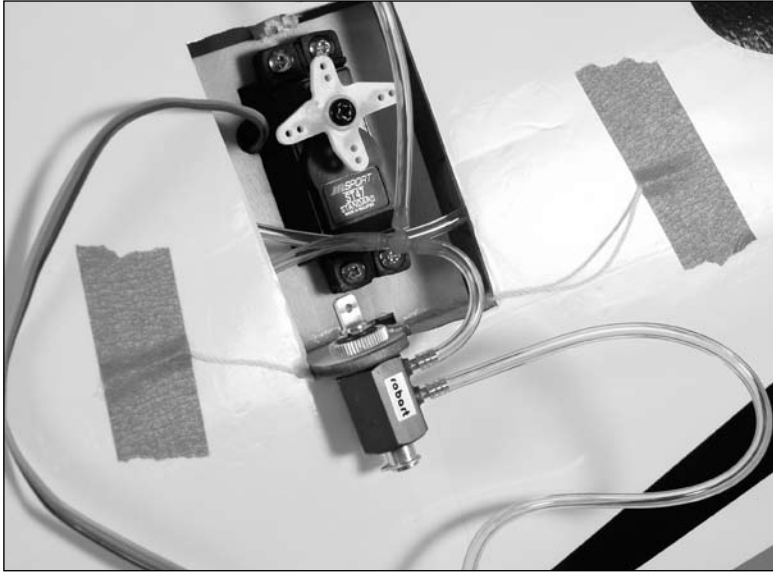

- 10. Connect a 6-inch piece of air line to the remaining fitting on the actuator valve. A female quick disconnect that mates to the male quick disconnect on the line coming from the air tank will need to be attached to this line.

- 11. Remove the servo horn from the retract servo. Use a pin drill and 5/64-inch (2mm) drill bit to enlarge to outer hole of the retract servo horn.

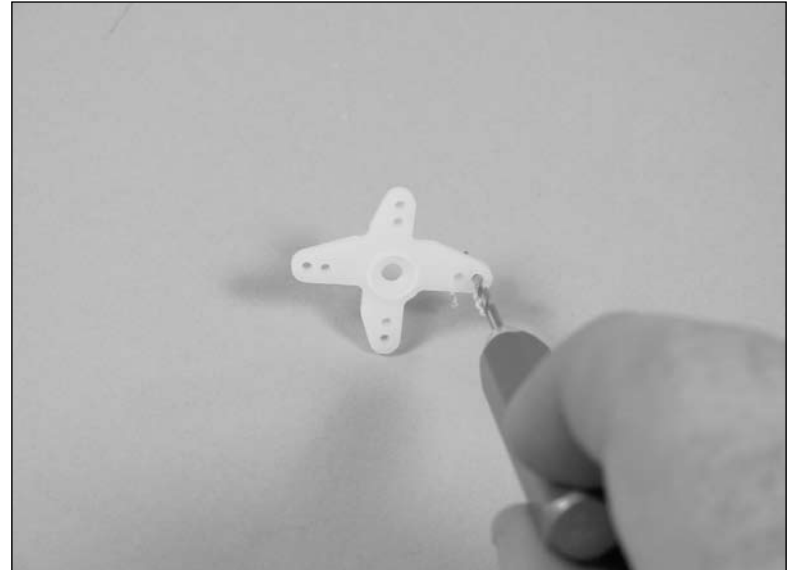

- 12. Slide the brass pushrod connector in the hole drilled in the previous step.



- 13. Secure the connector to the servo horn using a nylon connector backplate. You may use side cutters to trim the unused arms on the servo control horn.

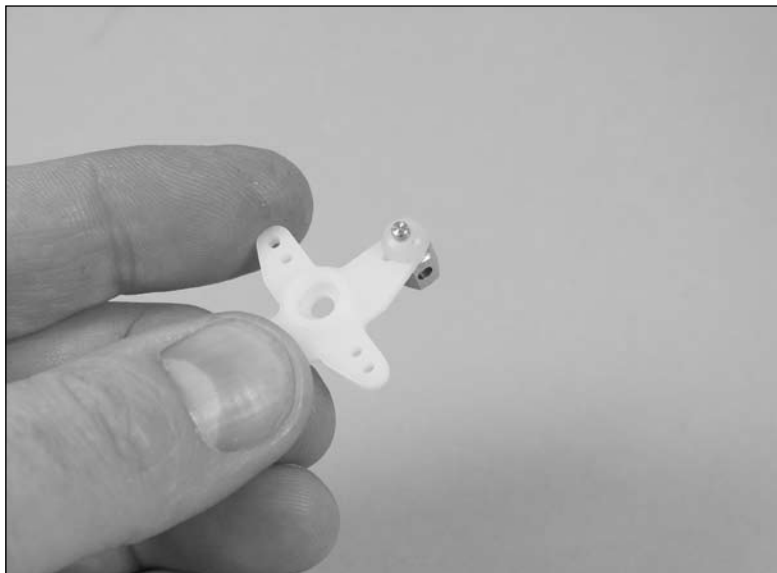

Note: You will need your transmitter and receiver for the next steps to set up your retract end points.

- 14. Inside the radio programming menu of travel adjustment, turn the travel adjustment down to 0 on both sides of the gear channel. Set the control horn on the servo where it sits at the neutral position as shown in the photo. Install the servo horn on the retract servo.

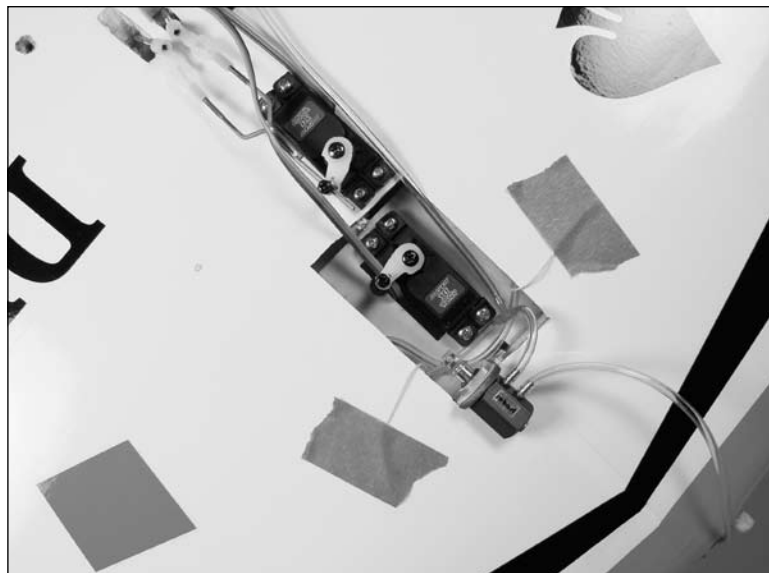

- 15. Thread a clevis onto a the 3-inch (76mm) pushrod wire. Make sure to slide a silicone clevis retainer onto the clevis before threading it onto the pushrod wire. Slide the pushrod into the pushrod connector and align the clevis with the hole in the actuator valve. Now hook up the clevis and set the valve to where the plunger is half way in between either side. Using threadlock, tighten the machine screw and proceed to the next step.

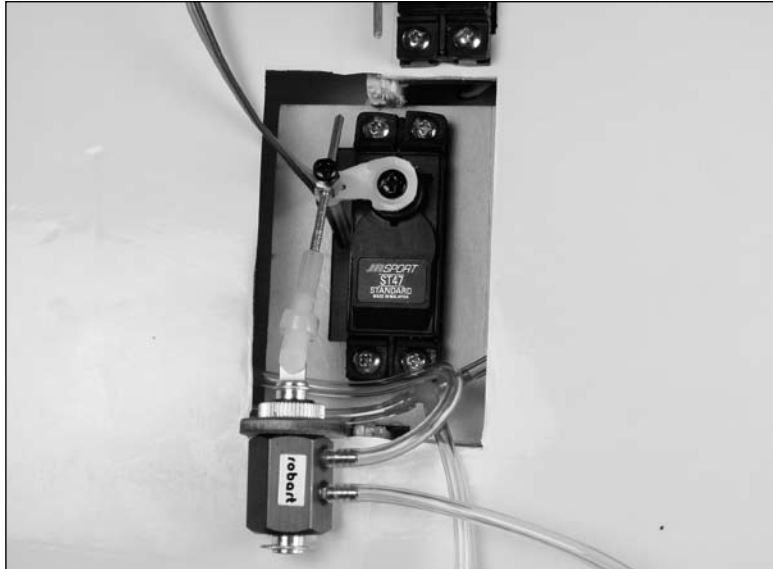

- 16. Now with the radio on, flip the retract switch to either side and in the travel adjust menu continue to dial in throw on one side until the plunger just touches one side. Now flip the retract switch in the opposite direction and turn the travel adjustment up until the plunger just touches the opposing side. Your retract servo should now be set up and not binding. Trim the pushrod with side cutters once you have the final adjustments complete.

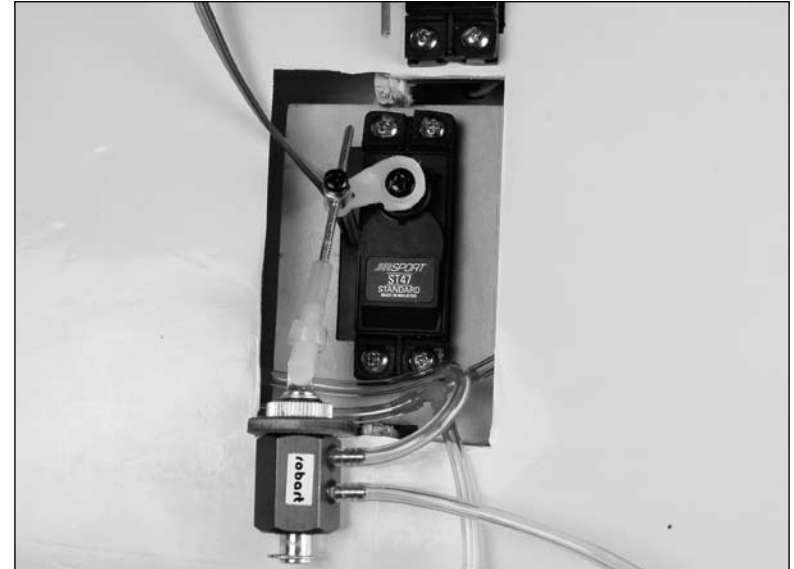

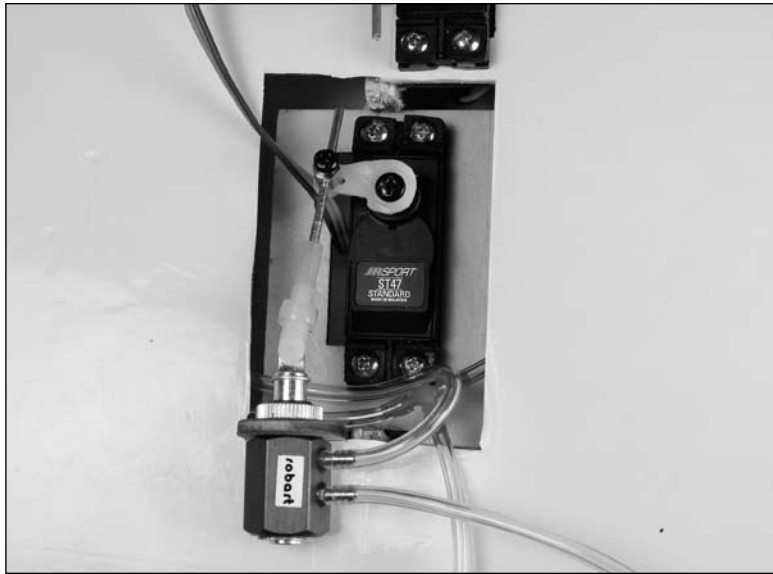

Hint: Try to keep the amounts equal for both up and down. You may need to remove the servo horn and adjust it on the servo shaft at least once during the alignment process.

Aileron and Throttle Servo Extensions

Required Parts

Wing center section Y-harness (2)
9-inch (228mm) servo extension (2)
6-inch (152mm) servo extension (2)

Required Tools and Adhesives

Low-tack tape Dental floss

- 1. Prepare the aileron servo extension by connecting two 9-inch (228mm) extensions to a Y-harness. The throttle extension will require two 6-inch (152mm) extensions and a Y-harness. Make sure to use string, dental floss, or a commercially available connectors to secure the extensions to the Y-harness.



Note: We used low-tack tape on each aileron extension lead to differentiate it from the throttle extension.

- 2. Tie the string on one side to the end of the throttle and aileron extensions. Repeat for the opposite side.

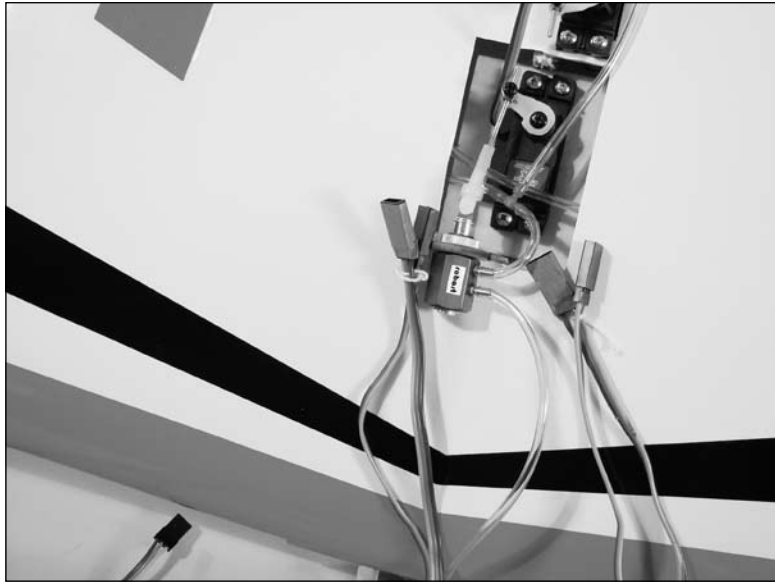

- 3. Use the string to pull the aileron and throttle extensions through the wing. The throttle extension will require routing through the opening above the wing tube as shown.

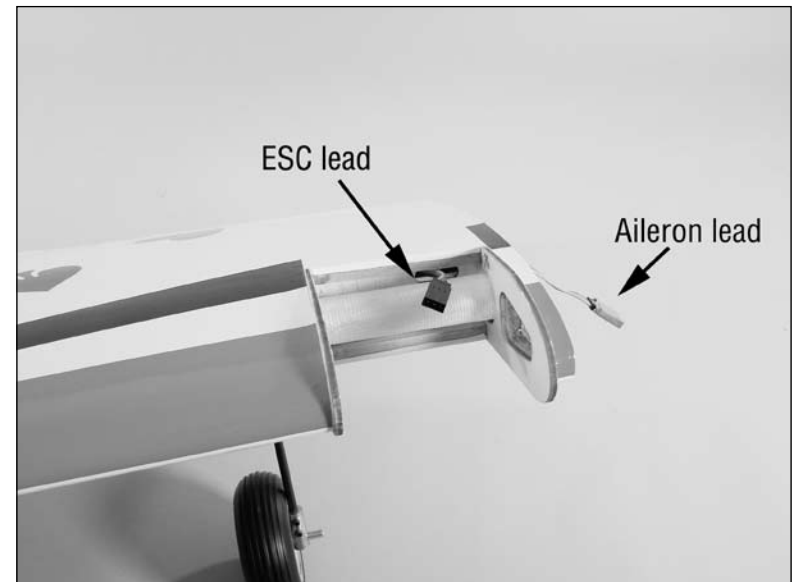
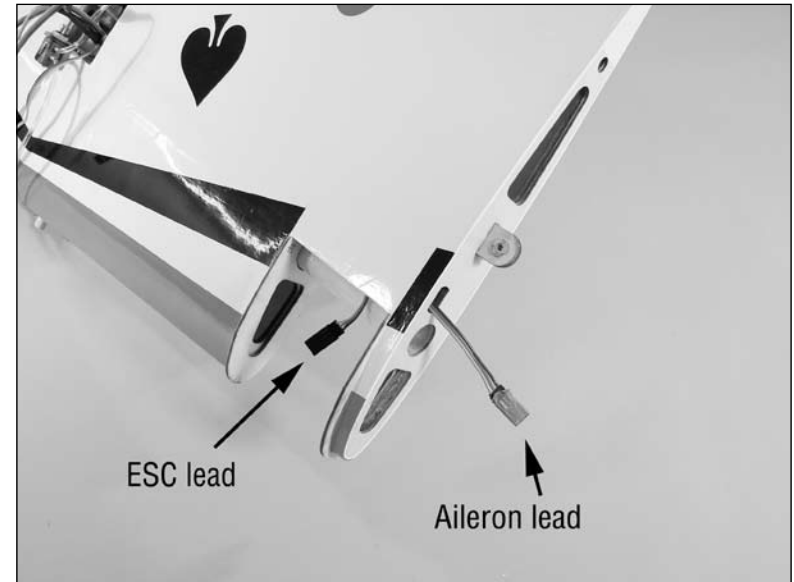

Power 25 Motor Installation

Required Parts

- Motor w/X-mount (2)
- Motor nacelle (right and left)
- 4-40 x 1-inch socket head screw (8)

Required Tools and Adhesives

- Phillips screwdriver: #2
- Threadlock
- Ball driver: 3/32-inch

- 1. Attach the X-mount to the Power 25 motor using the hardware provided with the motor and a #2 Phillips screwdriver. Make sure to use threadlock on the screws to prevent them from vibrating loose.



- 2. Pass the wires from the motor through the gap between the engine nacelle and firewall. The motor is secured to the firewall using four 4-40 x 1-inch socket head screws and a 3/32-inch ball wrench.



- 3. Repeat Steps 1 and 2 to install the remaining motor.

Power 32 Motor Installation

Required Parts

Motor w/X-mount (2) Spacer (8)
Motor nacelle (right and left)
4-40 x 1-inch socket head screw (8)

Required Tools and Adhesives

Phillips screwdriver: #2 Threadlock
Ball driver: 3/32-inch

Note: Using the Power 32 will provide you with strong aerobatic performance. Due to the nacelle design, installing the Power 32 takes more time as you will need to assemble the motor to its X-mount inside the nacelle. We have found it easiest to accomplish this while the nacelle is pointing towards the ground and holding the motor inside the nacelle while we attach the X-mount. The X-mount should sit on the back of the motor during this, providing you the ability to install each screw one at a time.

- ○ 1. The Power 32 motor will require spacers be installed between the mount and firewall. The image below illustrates this installation as it is difficult to see this spacer inside the engine nacelle when the motor is installed.



- ○ 2. Place the X-mount for the motor into the nacelle. Ensure the counter sunk holes in the X-mount face towards the firewall.



- ○ 3. Position the motor inside the nacelle.



- ○ 4. Pass the wires from the motor through the gap between the engine nacelle and firewall. The motor will be secured to the firewall using four 4-40 x 1-inch socket head screws and a 3/32-inch ball wrench in a later step.



- ○ 5. The screws to attach the X-mount to the motor will need to be installed using the openings from the backside of the firewall. Work slowly to install the four screws, and don't forget to use threadlock on these screws or they will vibrate loose.



Hint: You may want to magnetize your Phillips screwdriver to hold the screw during this operation.

- ○ 6. After the X-mount has been attached to the motor, secure the X-mount to the firewall. Use the spacers between the mount and firewall as shown previously. Use a 3/32-inch ball driver to tighten the four 4-40 x 1-inch socket head screws that secure the X-mount to the firewall. Make sure to use threadlock to prevent the screws from vibrating loose.



- 7. Repeat Steps 1 through 6 to install the remaining motor in the nacelle.



Propeller and Spinner Installation

Required Parts

Propeller (left and right)	Spinner w/ screw (left and right)
Propeller adapter (2)	Wing center section
60-amp speed control (2)	Hook and loop tape
Motor nacelle (right and left)	

Required Tools and Adhesives

Phillips screwdriver: #1	6-minute epoxy
Paper towels	Rubbing alcohol
Canopy glue	Mixing cups
Mixing sticks	Low-tack tape
Rotary tool w/ high speed cutting bit	

Note: Your model is equipped with counter-rotating spinners. When viewed from the cockpit, the left wing motor will rotate clockwise and the right wing motor will rotate counterclockwise. The standard rotation propeller is installed on the left motor and the pusher propeller is installed on the right motor.

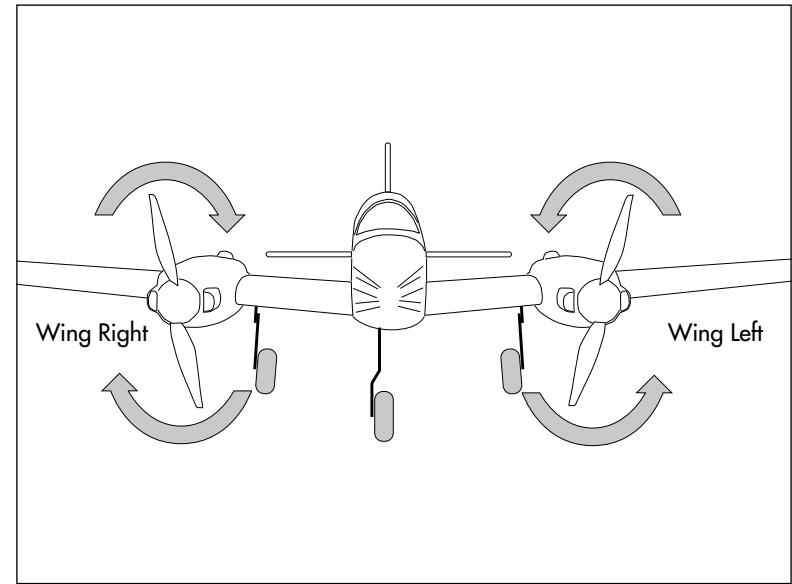

- 1. Pass the adapter for your motor into the spinner backplate. Slide the propeller onto the adapter.



Note: It may be necessary to relieve the back opening in the spinner back plate to accept the E-flite prop collet. We use a rotary tool with a high speed bit to accomplish this.

- 2. Thread the adapter nut onto the adapter, but do not tighten the nut at this time.



- 3. Slide the adapter assembly onto the motor shaft. With a gap of 5/64-inch (2mm) between the spinner backplate and front of the nacelle, tighten the adapter nut to secure the adapter to the motor shaft.

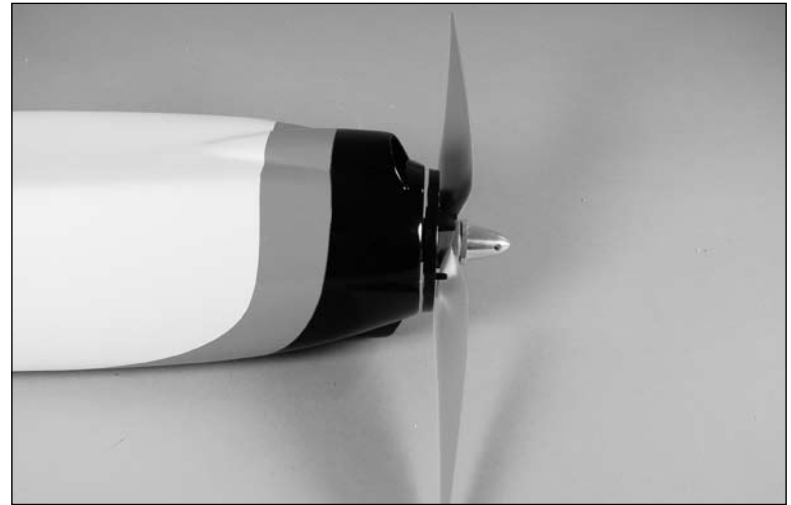

- 4. Use a #1 Phillips screwdriver to tighten the two 3mm x 10mm self-tapping screws that secure the spinner cone to the spinner backplate.

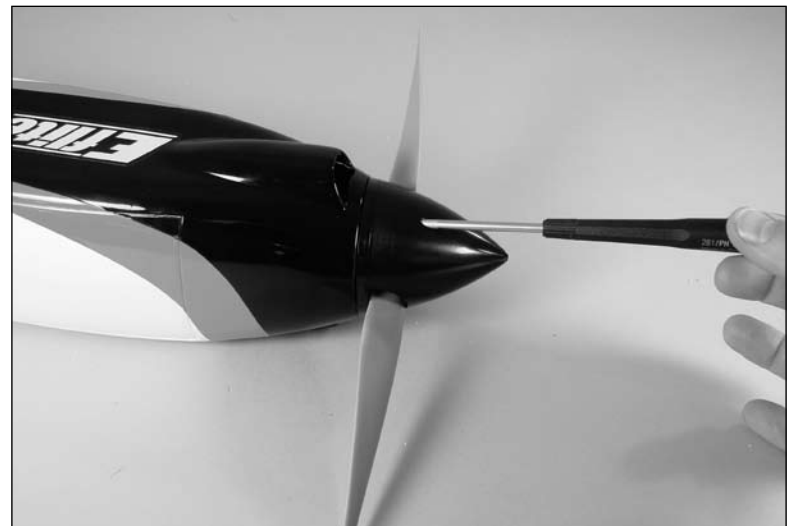

- ○ 5. Use hook and loop tape to attach the speed control to the inside of the motor nacelle.



- ○ 6. Test fit the motor nacelles to the wing. The E-flite decal will face out toward the tip of the wing.



- ○ 7. Once satisfied with the fit, remove the nacelle from the wing. Use 6-minute epoxy to glue the nacelle to the wing. Apply the epoxy to the exposed bare plywood of the wing, which is the junction where the nacelle meets the wing. Also apply epoxy to the inside of the nacelle where it will meet the plywood. Make a nice fillet of epoxy at this joint. Use low-tack tape to hold the nacelle in position while the epoxy cures.

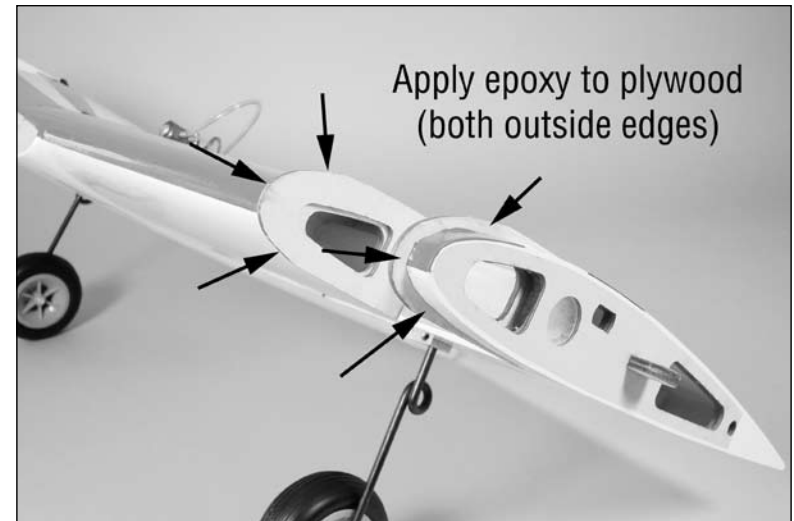

Note: Use paper towels and rubbing alcohol to clean up any excess epoxy that squeezes out from the nacelles onto the wing in this step.

- ○ 8. Once the epoxy has fully cured, use canopy glue to glue the aft edges of the nacelle to the wing top and bottom wing covering. The covering does not need to be removed from the wing for this. Use low-tack tape to hold the nacelle tight against the wing while the canopy glue cures.



- ○ 9. If using the E-flite 60 Amp ESC, you only need one of the BEC's to be active. To disarm the BEC on one of the ESC's, you will need to remove the red wire from the servo plug on the ESC. Tape this wire back on itself once completed. Now connect the lead from the ESC to the previously installed extension lead. Ensure you use some dental floss or a commercially available device to secure the connection.



- 10. Repeat Steps 1 through 9 to install the remaining propeller, spinner and ESC.

Wing Installation

Required Parts

Wing panel (right and left) Wing center section
Wing tube (2) 1/4-20 x 2-inch nylon bolt (2)
4-40 x 1-inch socket head bolt (2)

Required Tools and Adhesives

Ball driver: 3/32-inch Flat screwdriver

- ○ 1. Slide the wing tube into the socket in the wing center section.



- ○ 2. Slide an outer wing panel onto the wing tube. Guide the tab with the blind nut into the appropriate slot of the wing center section. Don't forget to plug the extension from the center section to the aileron servo.



- ○ 3. With the outer wing panel tight against the wing center section, use a 3/32-inch ball driver to install the 4-40 x 1-inch socket head bolt that secures the outer panel to the center section. Complete for the opposite wing panel.



- 4. Position the wing on the fuselage. Use two 1/4-20 x 2-inch nylon bolts and a flat screwdriver to secure the wing to the fuselage. Ensure you connect the air lines as well as the servo wires from the wing into the respective ports on the receiver before fully installing the wing.



Canopy and Gear Door Installation

Required Parts

Fuselage assembly	Canopy
Tie wrap (4)	Main gear door (right and left)

Required Tools and Adhesives

Low-tack tape	Canopy glue
Side cutters	Drill
Drill bit: 5/64-inch (2mm)	
Silicone adhesive	

Note: You may wish to install the optional cockpit kit at this time. Instructions have been provided with that kit on how to install it into your Deuces Wild.

- 1. Use canopy glue to attach the canopy to the fuselage. Use low-tack tape to hold the canopy in position until the glue has fully cured.



- ○ 2. Fill the retract system with a commercially available air pump and operate the retracts. With the main gear in the UP position, apply a bead of silicone adhesive to the strut wire and tape the gear cover in position on the wing. Set the wing aside and allow the adhesive to fully cure.

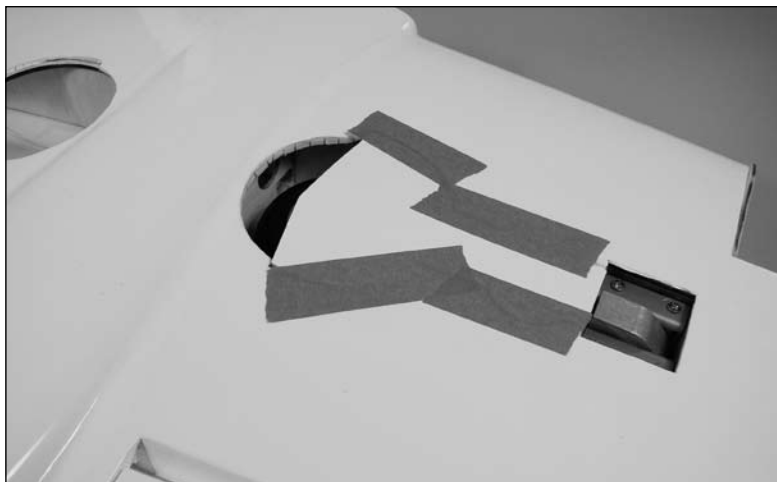

- ○ 3. Once cured, drill a 5/64-inch (2mm) hole on each side of the wire struts for the tie wraps to go through. Drill the holes as close to the top and bottom of the cover as possible.



- ○ 4. Use a tie wrap near the top and bottom of the gear cover to complete their installation. Use side cutters to trim the excess to prevent the tie wraps from interfering with the wheel or operation of the retracts.



Note: It is easier to remove the wheel then install the tie wrap near the wheel. Always remember to use threadlock on metal-to-metal fasteners to prevent them from vibrating loose.

- 5. Repeat Steps 2 through 4 to install the remaining gear cover.

Center of Gravity and Nose Cone Installation

Required Parts

Airframe
Nose Cone

Required Tools and Adhesives

Canopy Glue
Low-tack tape
Stick on weights (if needed)

An important part of preparing the aircraft for flight is properly balancing the model.

Caution: Do not inadvertently skip this step!

- 1. The recommended Center of Gravity (CG) location for the Deuces Wild is $3\frac{3}{4}$ – $4\frac{1}{16}$ -inch (95–103mm) back from the leading edge of the wing. Mark the location for the Center of Gravity on the top of the wing next to the fuselage as shown.

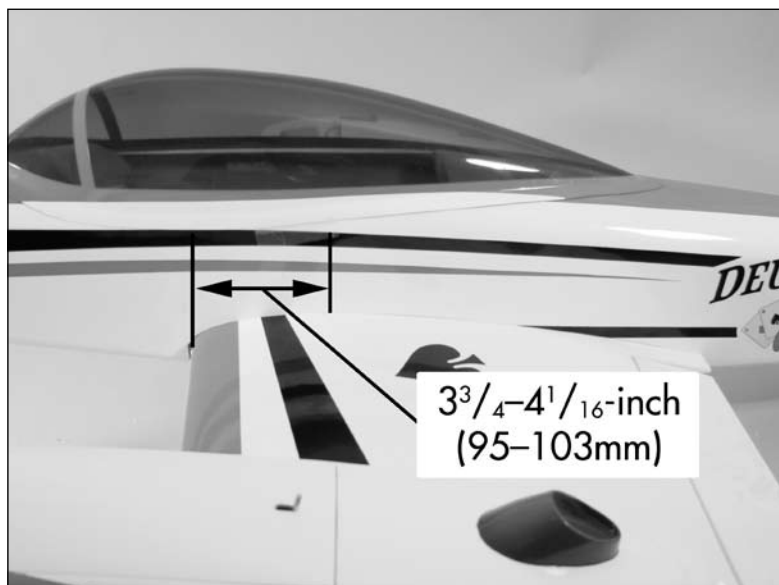

When balancing your Deuces Wild, support the plane upside down at the marks made on the top of the wing with your fingers or a commercially available balancing stand. Adjust components as necessary so the model hangs level or slightly nose down. This is the correct balance point for your model. You might find with the different power and landing gear configurations that you need to add a small amount of weight to either the front or back of the fuselage to achieve the correct balance.

If using retracts, balance the model with the gear retracted.

After the first flights, the CG position can be adjusted for your personal preference.

- 2. Use canopy glue to attach the nose cone to the front of the fuselage. Use low-tack tape to hold the cone in position until the glue has fully cured.



Important: The Center of Gravity must be checked before fully installing the nose cone. Due to the multiple configurations of retracts, fixed gear, and motor options, it is common to require some nose weight or possibly some tail weight to get the model to properly balance. The amount necessary may be small, and some configurations do not need weight at all. If you need nose weight, it is best to install it at the very far forward point of the nose cone.

Control Throws

- 1. Turn on the transmitter and receiver of your Deuces Wild. Check the movement of the rudder using the transmitter. When the stick is moved right, the rudder should also move right. Reverse the direction of the servo at the transmitter if necessary.
- 2. Check the movement of the elevator with the radio system. Moving the elevator stick down will make the airplane elevator move up.
- 3. Check the movement of the ailerons with the radio system. Moving the aileron stick right will make the right aileron move up and the left aileron move down.
- 4. Use a ruler to adjust the throw of the elevator, ailerons and rudder. Adjust the position of the pushrod at the control horn to achieve the following measurements when moving the sticks to their endpoints.

Ailerons	High Rate		Low Rate
Up	5/8-inch	Up	3/8-inch
Down	5/8-inch	Down	3/8-inch
	25% Expo		10% Expo
Elevator	High Rate		Low Rate
Up	7/8-inch	Up	1/2-inch
Down	7/8-inch	Down	1/2-inch
	20% Expo		10% Expo
Rudder	High Rate		Low Rate
Left	1 1/4-inch	Left	1/2-inch
Right	1 1/4-inch	Right	1/2-inch
	15% Expo		0% Expo
Flaps	Takeoff		Landing
	1 1/8-inch		5/8-inch

Elevator Compensation With Flaps

3/32-inch down

5/32-inch down

Note: Measurements are taken at the widest point on the surface.

These are general guidelines measured from our own flight tests. You can experiment with higher rates to match your preferred style of flying.

Range Test Your Radio

- 1. Before each flying session, be sure to range check your radio. This is accomplished by turning on your transmitter with the antenna collapsed. Turn on the receiver in your airplane. With your airplane on the ground and the engine running, you should be able to walk 30 paces (approximately 100 feet) away from your airplane and still have complete control of all functions.

If not, don't attempt to fly! Have your radio equipment checked out by the manufacturer.
- 2. Double-check that all controls (aileron, elevator, rudder and throttle) move in the correct direction.
- 3. Be sure that your transmitter batteries are fully charged, per the instructions included with your radio.

Preflight

Check Your Radio

Before going to the field, be sure that your batteries are fully charged per the instructions included with your radio. Charge both the transmitter and receiver pack for your airplane. Use the recommended charger supplied with your particular radio system, following the instructions provided with the radio. In most cases, the radio should be charged the night before going out flying.

Before each flying session, be sure to range check your radio. See your radio manual for the recommended range and instructions for your radio system. Each radio manufacturer specifies different procedures for their radio systems. Next, start the motor. With the model securely anchored, check the range again. The range test should not be significantly affected. If it is, don't attempt to fly! Have your radio equipment checked out by the manufacturer.

Note: Keep loose items that can get entangled in the propeller away from the prop. These include loose clothing, or other objects such as pencils and screwdrivers. Especially keep your hands away from the propeller.

Double-check that all controls (aileron, elevator, rudder and throttle) move in the correct direction.

Check the radio installation and make sure all the control surfaces are moving correctly (i.e. the correct direction and with the recommended throws). Test run the motor and make sure it transitions smoothly from off to full throttle and back. Also ensure the engine is installed according to the manufacturer's instructions, and it will operate consistently.

Check all the control horns, servo horns, and clevises to make sure they are secure and in good condition. Replace any items that would be considered questionable. Failure of any of these components in flight would mean the loss of your aircraft.

Flying Your Deuces Wild

With the counter-rotating props the elimination of torque delivers straight ahead acceleration and smooth flight characteristics. Plug in your batteries and install the battery hatches. Now move the throttle trim up until the motors come to life. This is your flight idle.

Taxi out to the runway and align yourself with the center line. Leave the flaps up for your first takeoff. They are not really needed for takeoff at all. Power up and steer the model straight. As the model approaches takeoff speed, pull back slightly on the elevator. Once you are airborne, retract the landing gear if you have installed retracts. Now you can enjoy the flight envelope of slow to high speed flight and you will find the Deuces Wild fully capable of just about any aerobatic maneuver you can think of.

Setting up for landing, you will find the Deuces Wild to slow up very well in the flight pattern. On the upwind leg drop the landing gear and the flaps. If the model balloons up badly, you will need more down elevator compensation to correct this. If the model dives down, you have too much down elevator compensation and will need to correct this. If you feel like the model is uncontrollable with too much elevator with the flaps down, you should retract the flaps and land, make an adjustment and try again. The model lands very well without the flaps. Make these adjustments on the elevator in 1/16-inch increments. The settings in the book are close when the CG is set as per the manual at around 4 inches. These elevator compensations will change slightly based on the CG setting of your model.

You will find this model floats very well and lands very slowly. It has no real bad habits and is one of the easiest flying models you will ever fly.

Single engine performance

The model has been designed from the beginning to be a very gentle flying model that can deliver performance when requested. If you lose a motor, the model will still fly very well, but your climb performance will suffer slightly. The best thing is to not turn into the dead engine, but with the larger tail, we have made turns using ailerons only into the dead motor along with touch and go's. We do not recommend you continue flying if you lose a motor. Set up and land and determine what the problem is.

We hope you enjoy flying your Deuces Wild ARF as much as we do.

Happy Landings!

Safety, Precautions, and Warnings

As the user of this product, you are solely responsible for operating it in a manner that does not endanger yourself and others or result in damage to the product or the property of others.

Carefully follow the directions and warnings for this and any optional support equipment (chargers, rechargeable battery packs, etc.) that you use.

This model is controlled by a radio signal that is subject to interference from many sources outside your control. This interference can cause momentary loss of control so it is necessary to always keep a safe distance in all directions around your model, as this margin will help to avoid collisions or injury.

- Always operate your model in an open area away from cars, traffic or people.
- Avoid operating your model in the street where injury or damage can occur.
- Never operate the model out into the street or populated areas for any reason.
- Never operate your model with low transmitter batteries.
- Carefully follow the directions and warnings for this and any optional support equipment (chargers, rechargeable battery packs, etc.) that you use.
- Keep all chemicals, small parts and anything electrical out of the reach of children.
- Moisture causes damage to electronics. Avoid water exposure to all equipment not specifically designed and protected for this purpose.

Warranty Information

Warranty Period

Horizon Hobby, Inc., (Horizon) warrants that the Products purchased (the "Product") will be free from defects in materials and workmanship at the date of purchase by the Purchaser.

Limited Warranty

(a) This warranty is limited to the original Purchaser ("Purchaser") and is not transferable. REPAIR OR REPLACEMENT AS PROVIDED UNDER THIS WARRANTY IS THE EXCLUSIVE REMEDY OF THE PURCHASER. This warranty covers only those Products purchased from an authorized Horizon dealer. Third party transactions are not covered by this warranty. Proof of purchase is required for warranty claims. Further, Horizon reserves the right to change or modify this warranty without notice and disclaims all other warranties, express or implied.

(b) Limitations- HORIZON MAKES NO WARRANTY OR REPRESENTATION, EXPRESS OR IMPLIED, ABOUT NON-INFRINGEMENT, MERCHANTABILITY OR FITNESS FOR A PARTICULAR PURPOSE OF THE PRODUCT. THE PURCHASER ACKNOWLEDGES THAT THEY ALONE HAVE DETERMINED THAT THE PRODUCT WILL SUITABLY MEET THE REQUIREMENTS OF THE PURCHASER'S INTENDED USE.

(c) Purchaser Remedy- Horizon's sole obligation hereunder shall be that Horizon will, at its option, (i) repair or (ii) replace, any Product determined by Horizon to be defective. In the event of a defect, these are the Purchaser's exclusive remedies. Horizon reserves the right to inspect any and all equipment involved in a warranty claim. Repair or replacement decisions are at the sole discretion of Horizon. This warranty does not cover cosmetic damage or damage due to acts of God, accident, misuse, abuse, negligence, commercial use, or modification of or to any part of the Product. This warranty does not cover damage due to improper installation, operation, maintenance, or attempted repair by anyone other than Horizon. Return of any goods by Purchaser must be approved in writing by Horizon before shipment.

Damage Limits

HORIZON SHALL NOT BE LIABLE FOR SPECIAL, INDIRECT OR CONSEQUENTIAL DAMAGES, LOSS OF PROFITS OR PRODUCTION OR COMMERCIAL LOSS IN ANY WAY CONNECTED WITH THE PRODUCT, WHETHER SUCH CLAIM IS BASED IN CONTRACT, WARRANTY, NEGLIGENCE, OR STRICT LIABILITY. Further, in no event shall the liability of Horizon exceed the individual price of the Product on which liability is asserted. As Horizon has no control over use, setup, final assembly, modification or misuse, no liability shall be assumed nor accepted for any resulting damage or injury. By the act of use, setup or assembly, the user accepts all resulting liability.

If you as the Purchaser or user are not prepared to accept the liability associated with the use of this Product, you are advised to return this Product immediately in new and unused condition to the place of purchase.

Law: These Terms are governed by Illinois law (without regard to conflict of law principals).

Safety Precautions

This is a sophisticated hobby Product and not a toy. It must be operated with caution and common sense and requires some basic mechanical ability. Failure to operate this Product in a safe and responsible manner could result in injury or damage to the Product or other property. This Product is not intended for use by children without direct adult supervision. The Product manual contains instructions for safety, operation and maintenance. It is essential to read and follow all the instructions and warnings in the manual, prior to assembly, setup or use, in order to operate correctly and avoid damage or injury.

Questions, Assistance, and Repairs

Your local hobby store and/or place of purchase cannot provide warranty support or repair. Once assembly, setup or use of the Product has been started, you must contact Horizon directly. This will enable Horizon to better answer your questions and service you in the event that you may need any assistance. For questions or assistance, please direct your email to productsupport@horizonhobby.com, or call 877.504.0233 toll free to speak to a service technician.

Inspection or Repairs

If this Product needs to be inspected or repaired, please call for a Return Merchandise Authorization (RMA). Pack the Product securely using a shipping carton. Please note that original boxes may be included, but are not designed to withstand the rigors of shipping without additional protection. Ship via a carrier that provides tracking and insurance for lost or damaged parcels, as **Horizon is not responsible for merchandise until it arrives and is accepted at our facility**. A Service Repair Request is available at www.horizonhobby.com on the "Support" tab. If you do not have internet access, please include a letter with your complete name, street address, email address and phone number where you can be reached during business days, your RMA number, a list of the included items, method of payment for any non-warranty expenses and a brief summary of the problem. Your original sales receipt must also be included for warranty consideration. Be sure your name, address, and RMA number are clearly written on the outside of the shipping carton.

Warranty Inspection and Repairs

To receive warranty service, you must include your original sales receipt verifying the proof-of-purchase date. Provided warranty conditions have been met, your Product will be repaired or replaced free of charge. Repair or replacement decisions are at the sole discretion of Horizon Hobby.

Non-Warranty Repairs

Should your repair not be covered by warranty the repair will be completed and payment will be required without notification or estimate of the expense unless the expense exceeds 50% of the retail purchase cost. By submitting the item for repair you are agreeing to payment of the repair without notification. Repair estimates are available upon request. You must include this request with your repair. Non-warranty repair estimates will be billed a minimum of ½ hour of labor. In addition you will be billed for return freight. Please advise us of your preferred method of payment. Horizon accepts money orders and cashiers checks, as well as Visa, MasterCard, American Express, and Discover cards.

If you choose to pay by credit card, please include your credit card number and expiration date. Any repair left unpaid or unclaimed after 90 days will be considered abandoned and will be disposed of accordingly. ***Please note: non-warranty repair is only available on electronics and model engines.***

Electronics and engines requiring inspection or repair should be shipped to the following address:

Horizon Service Center
4105 Fieldstone Road
Champaign, Illinois 61822

or

Horizon Hobby UK
Units 1-4, Ployters Road
Staple Tye - Southern Way
Harlow
Essex
CM187NS
United Kingdom

or

Horizon Technischer Service
Otto-Hahn-Str. 9a
25337 Elmshorn
Germany

All other Products requiring warranty inspection or repair should be shipped to the following address:

Horizon Support Team
4105 Fieldstone Road
Champaign, Illinois 61822

USA: Please call 1 877 504 0233 or visit horizonhobby.com to find our distributor for your country for support with any questions or concerns regarding this product or warranty.

UK: Please call +44 1279 641 097 or sales@horizonhobby.co.uk with any questions or concerns regarding this product or warranty.

Germany: Please call +49 4121 46199 66 or service@horizonhobby.de with any questions or concerns regarding this product or warranty.

Instructions for Disposal of WEEE by Users in the European Union

This product must not be disposed of with other waste. Instead, it is the user's responsibility to dispose of their waste equipment by handing it over to a designated collection point for the recycling of waste electrical and electronic equipment. The separate collection and recycling of your waste equipment at the time of disposal will help to conserve natural resources and ensure that it is recycled in a manner that protects human health and the environment. For more information about where you can drop off your waste equipment for recycling, please contact your local city office, your household waste disposal service or where you purchased the product.



2008 Official AMA National Model Aircraft Safety Code

GENERAL

- 1) I will not fly my model aircraft in sanctioned events, air shows or model flying demonstrations until it has been proven to be airworthy by having been previously, successfully flight tested.
- 2) I will not fly my model higher than approximately 400 feet within 3 miles of an airport without notifying the airport operator. I will give right-of-way and avoid flying in the proximity of full-scale aircraft. Where necessary, an observer shall be utilized to supervise flying to avoid having models fly in the proximity of full-scale aircraft.
- 3) Where established, I will abide by the safety rules for the flying site I use, and I will not willfully or deliberately fly my models in a careless, reckless and/or dangerous manner.
- 4) The maximum takeoff weight of a model is 55 pounds, except models flown under Experimental Aircraft rules.
- 5) I will not fly my model unless it is identified with my name and address or AMA number on or in the model. (This does not apply to models while being flown indoors.)
- 6) I will not operate models with metal-bladed propellers or with gaseous boosts, in which gases other than air enter their internal combustion engine(s); nor will I operate models with extremely hazardous fuels such as those containing tetranitromethane or hydrazine.

RADIO CONTROL

- 1) I will have completed a successful radio equipment ground range check before the first flight of a new or repaired model.
- 2) I will not fly my model aircraft in the presence of spectators until I become a qualified flier, unless assisted by an experienced helper.
- 3) At all flying sites a straight or curved line(s) must be established in front of which all flying takes place with the other side for spectators. Only personnel involved with flying the aircraft are allowed at or in front of the flight line. Intentional flying behind the flight line is prohibited.

- 4) I will operate my model using only radio control frequencies currently allowed by the Federal Communications Commission. (Only properly licensed Amateurs are authorized to operate equipment on Amateur Band frequencies.)
- 5) Flying sites separated by three miles or more are considered safe from site-to-site interference, even when both sites use the same frequencies. Any circumstances under three miles separation require a frequency management arrangement, which may be either an allocation of specific frequencies for each site or testing to determine that freedom from interference exists. Allocation plans or interference test reports shall be signed by the parties involved and provided to AMA Headquarters.

Documents of agreement and reports may exist between (1) two or more AMA Chartered Clubs, (2) AMA clubs and individual AMA members not associated with AMA Clubs, or (3) two or more individual AMA members.

- 6) For Combat, distance between combat engagement line and spectator line will be 500 feet per cubic inch of engine displacement. (Example: .40 engine = 200 feet.); electric motors will be based on equivalent combustion engine size. Additional safety requirements will be per the RC Combat section of the current Competition Regulations.
- 7) At air shows or model flying demonstrations, a single straight line must be established, one side of which is for flying, with the other side for spectators.
- 8) With the exception of events flown under AMA Competition rules, after launch, except for pilots or helpers being used, no powered model may be flown closer than 25 feet to any person.
- 9) Under no circumstances may a pilot or other person touch a powered model in flight.



© 2008 Horizon Hobby, Inc.
4105 Fieldstone Road
Champaign, Illinois 61822
(877) 504-0233
horizonhobby.com
E-fliteRC.com