AC 2011-2119: DEVELOPING DIGITAL/ANALOG TELECOMMUNICATION LABORATORY

Dr. Yuhong Zhang, Texas Southern University

Yuhong Zhang is an assistant professor at Texas Southern University

Xuemin Chen, Texas Southern University

Prof. Lawrence O Kehinde P.E., Texas Southern University

Developing Digital/Analog Telecommunication Laboratory

Abstract

Based on many years of teaching in Engineering Technology (ET), we found that many ET students experience a disconnection between theory and application of concepts. In addition, it is a challenge of keeping a student's interest peaked in the classroom or lab. All these facts motivated us to find a way to bridge the gap between theory and prototyping. The National Instruments (NI) Educational Laboratory Virtual Instrumentation Suite (NI ELVIS) is an education platform designed to address both instructor and student needs and is the ideal solution for both introductory and higher level courses. In this paper, we are proposing an innovation to current Engineering undergraduate lab courses by applying NI ELVIS and other products from the partner of NI.

Introduction

Engineering technology education focuses primarily on the applied aspects of science and engineering aimed at preparing graduates for practice in that portion of the technological spectrum^{1,2,3}. Current criterion-based standards for accrediting engineering technology programs specify that theory courses "should be accompanied by coordinated laboratory experiences...."². Therefore, hands-on laboratory has been an essential part of undergraduate engineering programs because it allows students to experience the backbone of science and engineering by conducting experiments, observing dynamic phenomena, testing hypotheses, learning from their mistakes, and reaching their own conclusions. The well prepared laboratory courses make the students be able to reinforce the theory they see in textbooks with in-class demonstrations and laboratory exercises.

In the Electronics Engineering Technology (ELET) and Computer Engineering Technology (CMET) programs at Texas Southern University (TSU), lectures and laboratories are presented in separate, but co-requisite courses. In the lecture course, students learn theoretical concept and in the corresponding lab, students conduct experiments to test the theory they learned in the classroom. In order to achieve the above goal, the hand-on laboratory equipments are necessary. For instance, we found that it is not convenient for students to test the Fourier transform and modulation theorem learned from the communication system course using only traditional equipments, like meter, oscilloscope, and function generator. In another words, with these traditional equipments, it's hard to achieve the objective that the lab experiments help the students understanding the contents they learned in the classroom. The students experienced a disconnection between theory and application of concepts. We has been tried to find a way to bridge the gap between the theory and real world for these undergraduate students⁴.

All these facts motivated us to build a digital/analog telecommunication laboratory with which a significant improvement for two lab courses "ELET 311: lab of communication systems" and "CMET 417: lab of Data communication methods" will be achieved. The National Instruments Educational Laboratory Virtual Instrumentation Suite (NI ELVIS) includes 12 of the most commonly used laboratory instruments including an oscilloscope (scope), digital multimeter

(DMM), function generator and others in a single platform. It is an education platform for both introductory and higher level courses⁵.

Introduction of Emona DATEx⁶

The Digital Analog Telecommunication EXperimenter unit (DATEx) is an add-on board for the NI ELVIS used for teaching analog and digital Telecommunications theory to university students⁶. Figure 1 shows DATEx unit with NI ELVIS

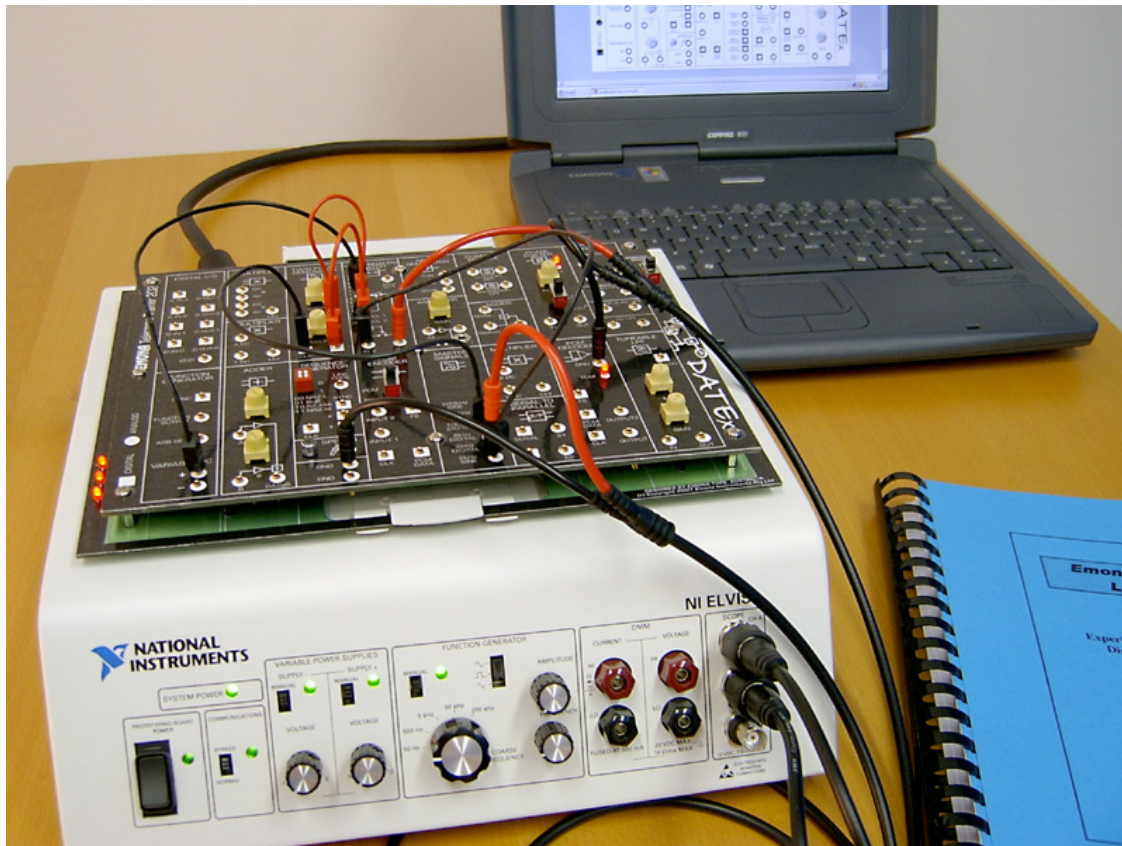

Figure 1: Emona DATEx and NI ELVIS

With Emona DATEx, over 29 analog and digital telecom's experiments can be implemented on one board, plugged into the NI ELVIS platform. These experiments include basic analog communication experiments, such as amplitude modulation (AM), frequency modulation (FM), phase modulation (PM) and digital communication experiments including sampling, pulse-code modulation (PCM), amplitude-shift keying (ASK), quadrature phase shift keying (QPSK), frequency-shift keying (FSK) and more. In addition, it also has the PC-controlled capabilities, such as on-screen control of hardware circuit blocks running Labview, automated signal processing and analysis using ELVIS instruments and building of integrated hardware-in-the-loop signal control programs with Labview controlling electronic circuit blocks.

DATEx has a unique "block diagram approach" to modeling telecommunications experiments. It provides a selection of individual circuit blocks. These circuit blocks are then patched together according to the block diagram. For example, for QPSK, the block diagram corresponding to the mathematical equation

$$x_q(t) \cos(\omega_c t) + x_p(t) \sin(\omega_c t)$$

is shown in Figure 2, and the patched circuit block is shown in Figure 3. In addition, all DATEX control knobs and switches can be controlled from a Soft Front Panel (SFP). This gives students an easy introduction to controlling hardware and signals via PC. Figure 4 presents the DATEX's SFP.

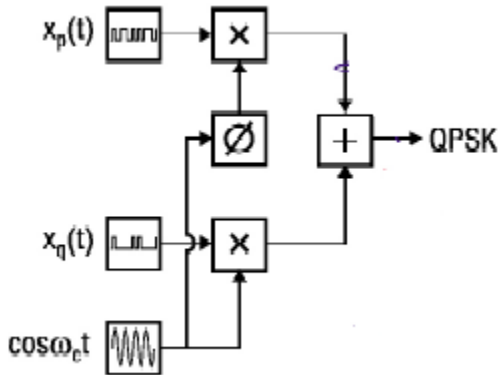

Figure 2: Block diagram of QPSK

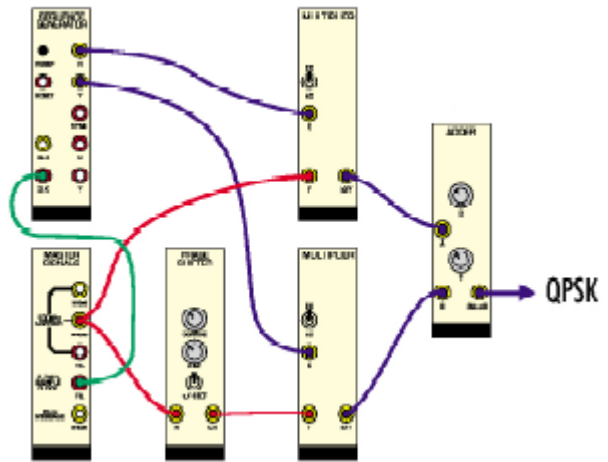

Figure 3: Wire connection of module for QPSK

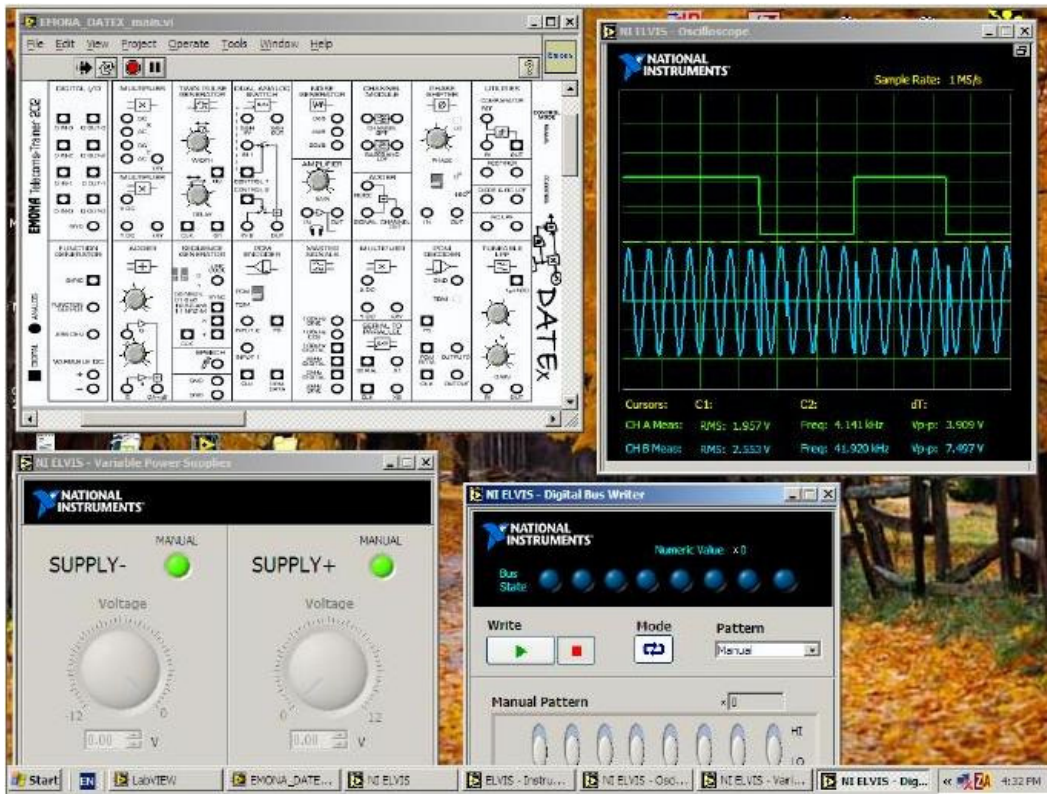

Figure 4: DATEX SFP functions alongside ELVIS SFP functions.

When students have a deep understanding of the principle of modulation and coding, they are then ready to apply this theoretical knowledge to use real radio frequency (RF) equipment such as NI's PXI which they may find in the advanced labs as well as in industry. The use of DATEX enables an easy progression of understanding from the math and theory through modelling, and then to use of real RF in industry. In this way, students learn the fundamental theory in a hands-on way with DATEX/ELVIS in college, building all the way their understanding and use of LabVIEW, and then apply their knowledge later on real NI RF equipment.

Case Study

The course "ELET 331: Communication systems", which focused on the analog telecommunication theory, is offered to junior or senior year students. It requires students have the background in calculus, linear algebra, basic electronics circuits, linear system theory, and probability and random variables in which our students are in a disadvantage position. Many of them experienced difficulty to understand the digital/analog telecommunication principle and concept⁷. We have desired helpful equipment for years and finally find the Emona DATEX is the right one. Because of the budgetary limitation, we bought only two Emona DATEX telecommunication boards in the summer of 2009. We used them combined with NI ELVIS II work station for the Lab of above course. Our students did many experiments such as AM, AM demodulation, FM, FM demodulation, Sampling and reconstruction, PCM encoding/decoding, ASK, FSK and QPSK. Specially, as a course project, students used this equipment recording their own speech signals, applied various modulation techniques they learned in classroom to process and transmit these signals and finally obtained the recovered speech signal from the receiver. These kinds of experiments not only stimulated students' interest but also enhanced their understanding of the principle of communication systems.

Both Figure 9 and Figure 10 below show the wave form obtained by students from the lab experiments. They are Amplitude Modulation (AM) signal and Amplitude Shift Keying (ASK) signal, respectively. Next, we will use two experiments, AM and ASK as examples to show how these lab experiments helping our students understanding the concept or principle they learned in classroom.

A. Experiment: Amplitude modulation⁸

In an AM communication system, speech and music are converted into an electrical signal using a device such as a microphone. This electrical signal is called the message or baseband signal. The message signal is then used to electrically vary the amplitude of a pure sine wave called the carrier. The carrier usually has a frequency that is much higher than the message's frequency (see Figure 5).

In the classroom's telecommunication theory, the students learned that the mathematical model that defines the AM signal is:

$$AM = (DC + message) \times \text{the carrier.}$$

When the message is a simple sine wave (like in Figure 5), the AM signal consists of three sine waves:

- One at the carrier frequency
- One with a frequency equal to the sum of the carrier and message frequencies

- One with a frequency equal to the difference between the carrier and message frequencies.

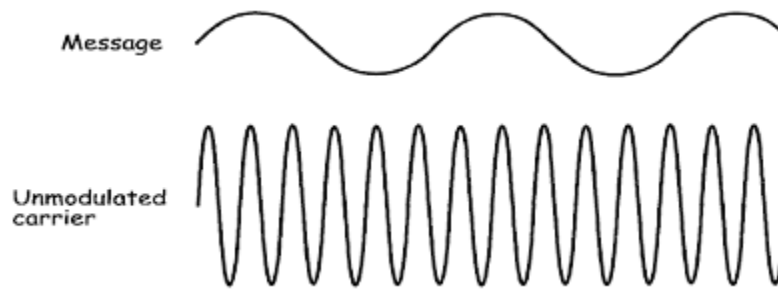

Figure 5: Original message and high frequency carrier wave form

Figure 6 below shows the AM signal. These dotted lines are known as the signal's envelope. The upper envelope is the same shape as the message. The lower envelope is also the same shape but upside-down (inverted).

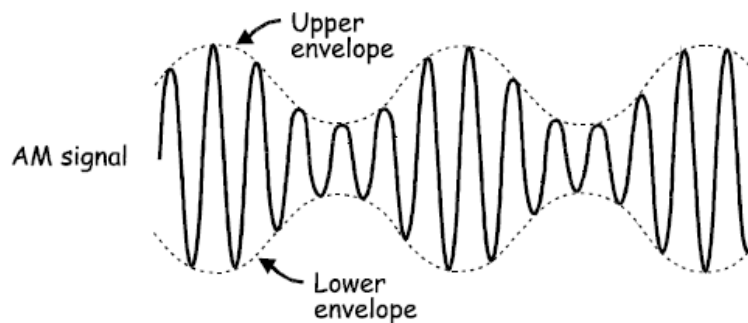

Figure 6: AM signal wave form

In this experiment, students used the Emona DATEx to generate a real AM signal by implementing its mathematical model. They added a DC component to a pure sine wave to create a message signal and then multiplied it with another sine wave at a higher frequency (the carrier). They examined the AM signal using the scope and compared it to the original message. They also recorded their speech as the message instead of a simple sine wave. Following this, they adjusted the message signal's amplitude and observed how it affected the modulated carrier. They also observed the effects of modulating the carrier too much. Finally, students measured the AM signal's depth of modulation using a scope.

The set-up in Figure 7 can be represented by the block diagram in Figure 8 below. With values, the equation becomes:

$$AM = (1V_{DC} + 1V_{p-p} \text{ 2kHz sine}) \times 4V_{p-p} \text{ 100kHz sine.}$$

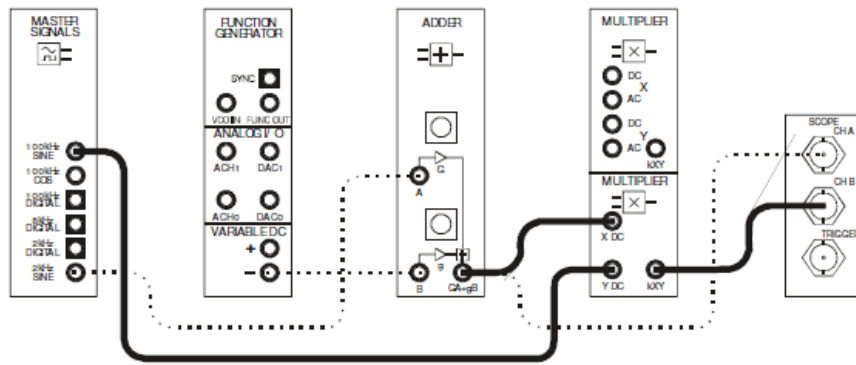

Figure 7: The wire connection of AM signal generation

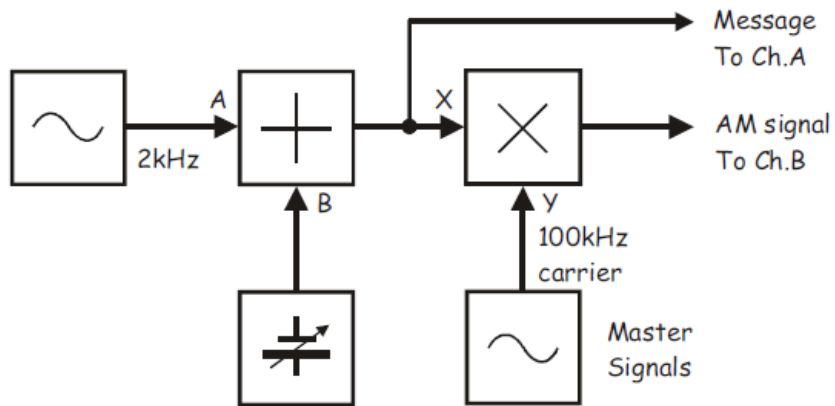

Figure 8: Block diagram of AM signal generation

Students obtained the AM signal and showed in the scope in Figure 9. The experiment enhanced students' understanding of amplitude modulation. Specially, they observed what the under modulation and over modulation look like.

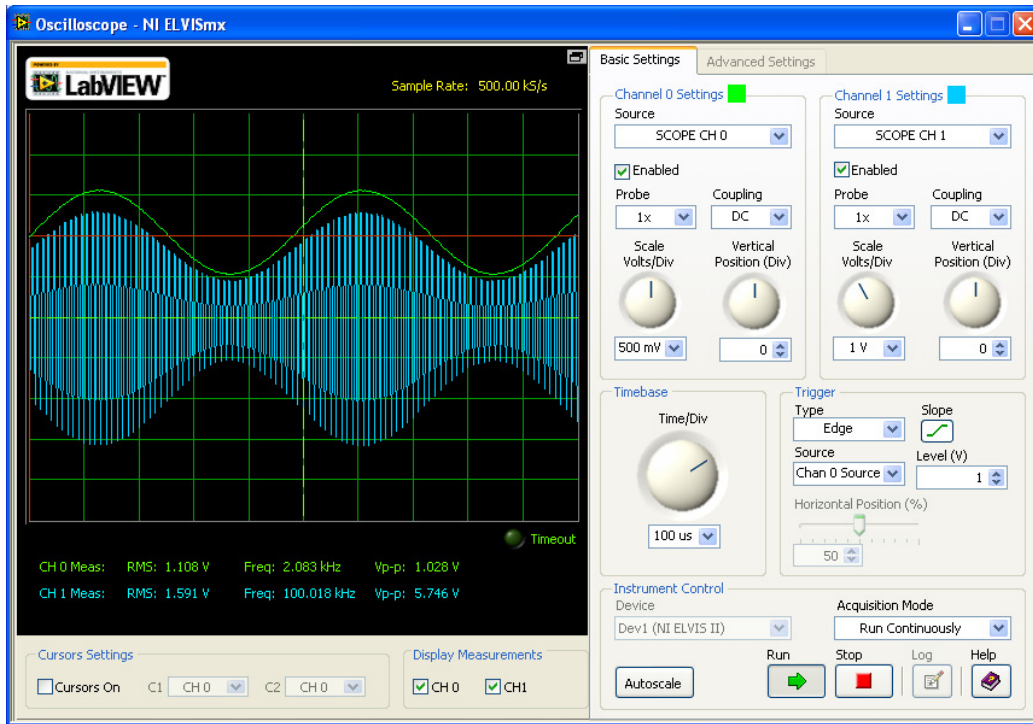

Figure 9: Original sine wave and the AM wave form

B. Experiment – Amplitude Shift Keying⁸

Frequency Division Multiplexing (FDM) is used for digital communications and uses the same modulation schemes available to analog communications including: AM, DSBSC and FM. When AM is used for multiplexing digital data, it is known as amplitude shift keying (ASK). Figure 10 below shows what an ASK signal looks like. Notice that the ASK signal's upper and lower limits (the envelopes) are the same shape as the data stream (though the lower envelope is inverted).

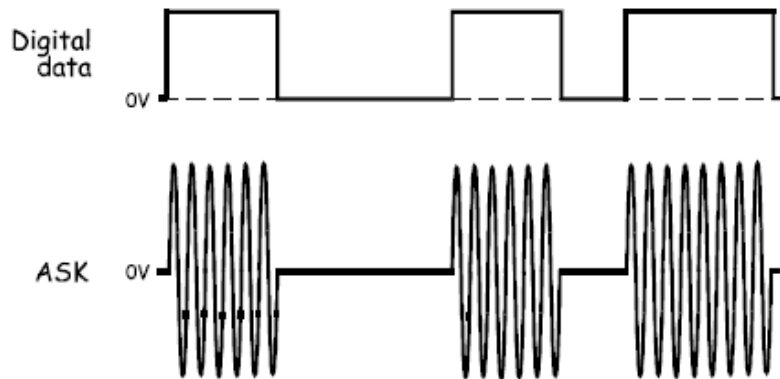

Figure 10: The original digital signal and its corresponding ASK signal

In this experiment, students employed the Emona DATEx to generate an ASK signal using the switching method. Digital data for the message is modeled by the Sequence Generator module. They would then recover the data using a simple envelope detector and observe its distortion. Finally, they used a comparator to restore the data

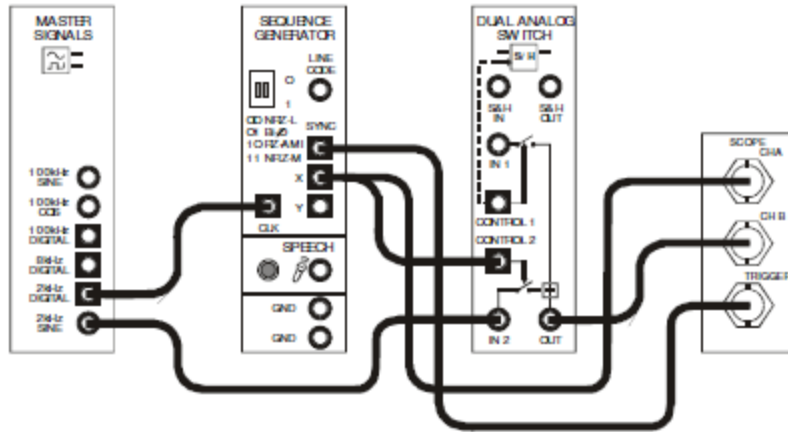

Figure 11: The set-up connection of ASK Lab

This set-up (Figure 11) can be represented by the block diagram in Figure 12 below. The Sequence Generator module is used to model a digital signal and its synchronised output is used to trigger the scope to provide a stable display. The Dual Analog Switch module is used to generate the ASK signal.

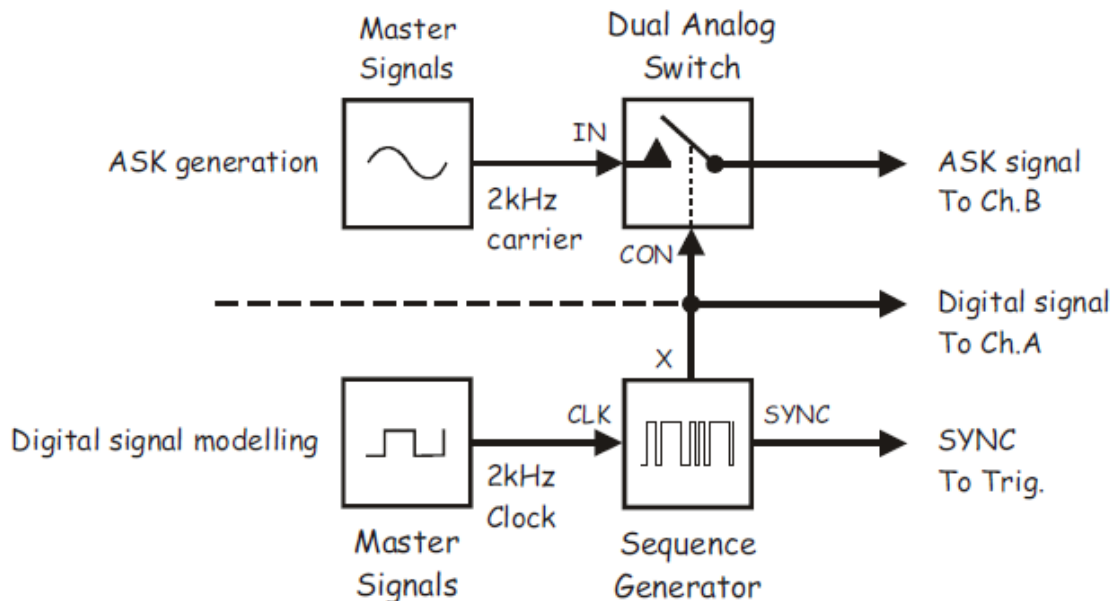

Figure 12: Block diagram of ASK generation

The ASK wave form is presented in Figure 13.

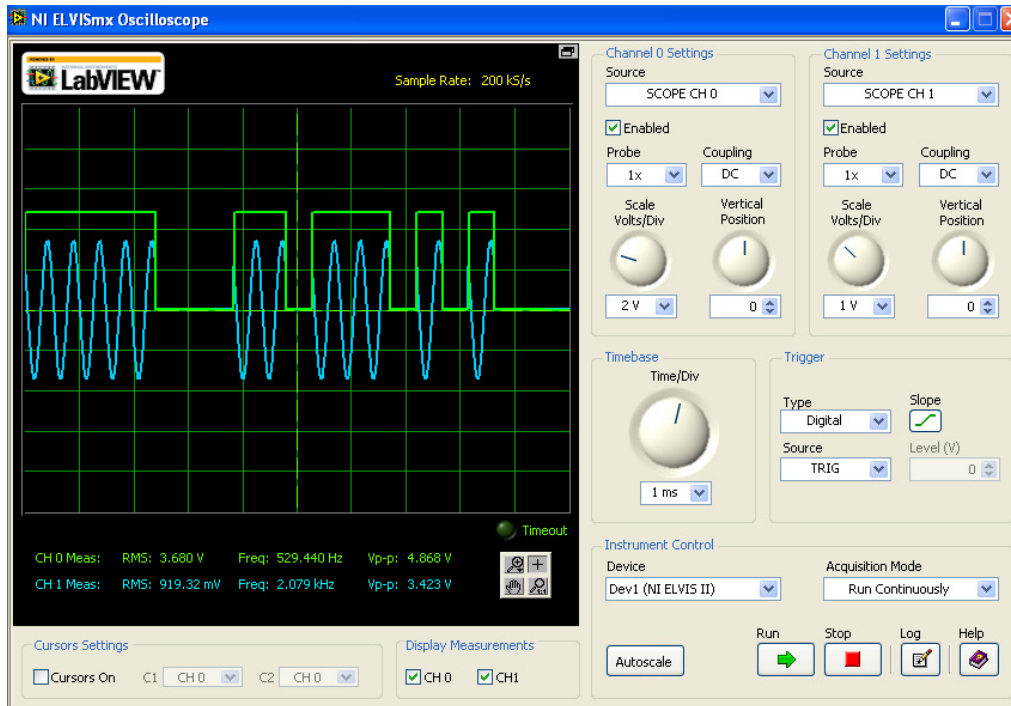

Figure 13: ASK signal wave form

The combination of Emona DATEx and NI ELVIS II for digital/analog telecommunication laboratory has proven effective for reinforcing telecommunication principal and concept. The students' survey also responds favorably to using these equipments.

Conclusions

Engineering Technology education focuses primarily on the application of science and engineering. Therefore, hands-on laboratories have been an essential part of undergraduate engineering programs. The National Instruments Educational Laboratory Virtual Instrumentation Suite (NI ELVIS) is an education platform designed to address both instructor and student needs and is the ideal solution for both introductory and higher level courses. Therefore, with NI ELVIS and its extensions, a completely consistent laboratory course framework can be established in the Department of Engineering Technology that covers material from the first year's DC, AC circuit design, second year's analog/digital electronics design, to the third or fourth year's telecommunication systems lab, data communication method lab, control system lab and digital signal processing lab. By taking advantage of these consistent Labs, our students are able to reinforce the theory they see in textbooks with in-class demonstrations and laboratory exercises. This kind of state-of-art laboratory and technology will help our engineering technology education better prepare students for careers in industry.

Acknowledgements

This work is partially supported by the National Science Foundation under Grant Numbers DUE-0942778 and HRD-0928921.

References:

- 1 http://en.wikipedia.org/wiki/Engineering_technology.
- 2 <http://www.coe.neu.edu/Depts/SET/set/whatisset.html>
- 3 <http://www.careercornerstone.org/pdf/engtech/engtech.pdf>
- 4 M.L. Good, N.F. Lane, "Producing the Finest Scientists and Engineers for the 21st Century", *Science*, Vol. 266, pp. 741-743, November 1994.
- 5 <http://www.ni.com/nielvis/>
- 6 <http://zone.ni.com/devzone/cda/tut/p/id/8657>
- 7 Y. Zhang, "The Application of MATLAB to Teaching Communication Systems" *Proceedings of ASEE annual conference and exposition*, Austin, USA, June 14-17, 2009.
- 8 Emona DATex Lab Manual.