



TURCK
works

Industrial
Automation

DeviceNet™

Troubleshooting Guide



www.turck.com

Table of Contents

1. Scope	2
1.1 Network Components	
1.2 Wiring and Connector Pin Definitions	
1.3 DeviceNet Cable Classification	
1.3.1 Thick Cable and Cable II	
1.3.2 Thin Cable and Cable I	
1.3.3 Flat Cable	
2. Quick Start	7
2.1 Know the Network Layout	
2.1.1 Network Topology	
2.1.2 Location of Nodes	
2.1.3 Location of Power Supplies	
2.2 When Things Go Wrong	
2.2.1 Symptoms of Physical Media Problems	
2.2.2. Symptoms of Node Problems	
2.2.3 Symptoms of Network Power Distribution Problems	
2.2.4 Network Failure	
3. Network Tests	9
3.1 Termination Test	
3.2 Network Power Supply Ground Test	
3.3 Network Power Common Mode Voltage Test	
3.4 CANH/CANL Voltage Test	
3.5 CAN Transceiver Resistance Test	
3.6 ESD Discharge Test	
4. Setting Node Address and Communication Rate	14
4.1 Hardware Address/Communication Rate Configuration	
4.2 Software Address/Communication Rate Configuration	
4.3 Rotary Switches	

1. Scope

The purpose of this troubleshooting guide is to direct qualified service personnel to the causes of network problems and provide remedies. The primary goal of troubleshooting is to minimize network downtime.

Test procedures described in this Troubleshooting Guide require the use of test equipment to measure voltage, current, and resistance of the physical media layer. It is usually sufficient to have a true RSM multimeter, such as Fluke® 87-3 Digital Multimeter or similar to run tests and obtain reliable measurements.

For information on designing DeviceNet™ systems, refer to ODVA publication 27: “DeviceNet Planning and Installation Manual”.

1.1 Network Components

DeviceNet uses a trunk line and drop line topology to connect nodes for communication. Here is an example:

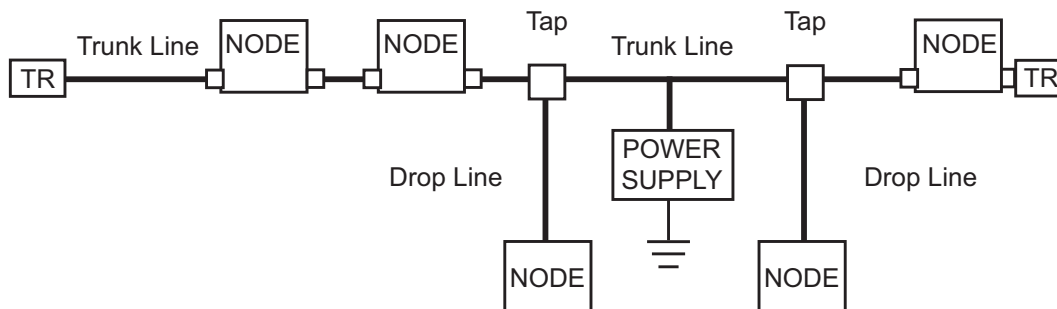

TR = Terminating Resistor

Component	Description
Trunk Line	The network cable between terminators. It is usually a “thick” cable.
Drop Line	The network cable between the trunk and nodes. Each drop line may be no longer than 6 meters (20 feet)
Tap	A branching point from the trunk line. There may be one node on a drop line, as with a tee tap, or multiple drop lines, as with a multiport junction box.
Terminating Resistor	The 121 Ohm resistor that is connected to the end of the Trunk Line. There are two terminators per network.
Node	An addressable device that communicates on the network. There may be as many as 64 nodes per network.
Power Supply	The 24-volt DC source that powers network communication. There may be multiple power supplies on a network, located anywhere on the network.

1.2 Wiring and Connector Pin Definitions

There are five conductors in DeviceNet cables.

There are three connector types commonly used on DeviceNet systems: 7/8 16 *minifast*® (mini), M12 *eufofast*® (micro), and screw terminal (open). Table I shows the connector pin definitions and Table II shows the connector styles.

Name	Wire Color	Description
Shield Drain	Bare	Connection to the shields in the cable
V+	Red	Connection to the bus 24 VDC supply
V-	Black	Connection to the bus supply common (0 VDC)
CANH	Blue	Data connection (high differential)
CANL	White	Data connection (low differential)

1.3 DeviceNet™ Cable Classification

Table I: Pin Definitions



Male <i>mini</i> Connector	Female <i>mini</i> Connector	Male <i>micro</i> Connector	Female <i>micro</i> Connector	Open Female Connector Rear View
				
1 = Bare (Drain) 2 = Red (V+) 3 = Black (V-) 4 = White (CANH) 5 = Blue (CANL)		1 = Bare (Drain) 2 = Red (V+) 3 = Black (V-) 4 = White (CANH) 5 = Blue (CANL)		5 = Red (V+) 4 = White (CANH) 3 = Bare (Drain) 2 = Blue (CANL) 1 = Black (V-)

Table II: Connector Styles

	<i>minifast (mini)</i>	<i>eufofast (micro)</i>	Open Style Front View
Male Connectors			
Female Connectors			

DeviceNet cables are classified according to DeviceNet Specification¹ as:

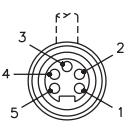
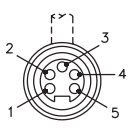
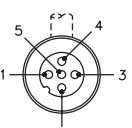
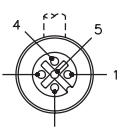
- **Round Cables**
 - Thick Cable or Cable II
 - Thin Cable or Cable I
- **Flat Cables**

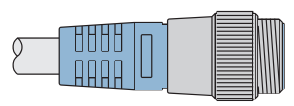
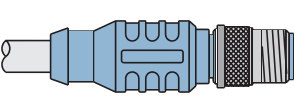
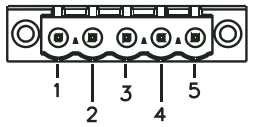
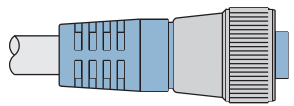
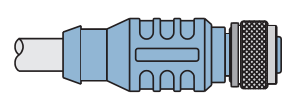
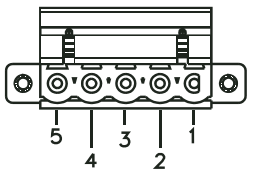
Table III: Cable Specifications (provides data for each cable type listed in the DeviceNet Specification)

Data Pair	Thick Cable	Cable II	Thin Cable	Cable I	Flat Cable
Min. Conductor Size: 19 strands min.	#18	#18	#24	#24	#16
Insulation Diameter nominal	0.150 in	0.150 in	0.077 in	0.077	0.110 in
Color	CAN_H White CAN_L Light Blue				
Impedance		120 Ohm +/-	10% @ MHz		
Max. Propagation Delay	1.36 nSec/ft	1.36 nSec/ft	1.36 nSec/ft	1.36 nSec/ft	1.60 nSec/ft
DCR - at 20 degrees C (max)	6.9 Ohms /1000 ft	6.9 Ohms /1000 ft	6.9 Ohms /1000 ft	28 Ohms /1000 ft	4.9 Ohms /1000 ft
Tape Shield	2 mil/1 mil, Al/Mylar	1 mil/1 mil, Al/Mylar	2 mil/1 mil, Al/Mylar	1 mil/1 mil, Al/Mylar	N/A
Power Pair					
Min. Conductor Size	#15	#15	#22	#22	#16
Insulation Diameter nominal	0.098 in	0.098 in	0.055 in	0.055 in	0.110 in
Color	V+ Red V- Black				
DCR - at 20 degrees C	3.6 Ohms /1000 ft	3.6 Ohms /1000 ft	17.5 Ohms /1000 ft	17.5 Ohms /1000 ft	4.9 Ohms /1000 ft
Tape Shield	1 mil/1 mil, Al/Mylar	1 mil/1 mil, Al/Mylar	1 mil/1 mil, Al/Mylar	1 mil/1 mil, Al/Mylar	N/A
General Specifications					
Outside Diameter	0.410 - 0.490"	Specified by Vendor	0.240 - 0.280"	Specified by Vendor	N/A
Bent Radius (d = diameter)	7 x d, fixed 20 x d, flex	Suitable for Application	7 x d, fixed 20 x d, flex	Suitable for Application	10 x diameter
Drain Wire	#18	#18	#22	#22	N/A
Agency Certification	NEC (UL) CL2/CL3 min.	Compliant w/local gov't regulations	NEC (UL) CL2/CL3 min.	Compliant w/local gov't regulations	NEC (UL) CL2 min.
Overall Shield	Braid 36 AWG or 0.12 mm Cu	Braid 36 AWG or 0.12 mm Cu	Tape 1 mil/1 mil, Al/Mylar	Tape 1 mil/1 mil, Al/Mylar	N/A

¹ = ODVA: DeviceNet Specifications Volume I and II, Rev 2.0, Errata 3 & 4

1.3.1 Thick Cable and Cable II

The maximum cable length used in trunk-drop topology depends on the data rate:

Table IV: Thick Cable and Cable II Topology

Communication Rate	Network Length	Trunk Length	Maximum Drop	Cumulative Drop
125 kb	500 m (1640 ft)	500 m (1640 ft)	6 m (20 ft)	156 m (512 ft)
250 kb	250 m (820 ft)	250 m (820 ft)	6 m (20 ft)	78 m (256 ft)
500 kb	100 m (328 ft)	100 m (328 ft)	6 m (20 ft)	39 m (128 ft)

The length of the network is the sum of the trunk length and cumulative drop length.

Thick Cable Capacity

The power distribution chart, Figure 1, shows the maximum allowed current through the power conductors of the thick cable. Distance is measured from a single 24 VDC power source. If the maximum current exceeds the specified value at any given point on the network, the power supply systems should be re-designed. Figure 1 provides thick cable current ratings.

Figure 1: Current available through power conductors of thick cable

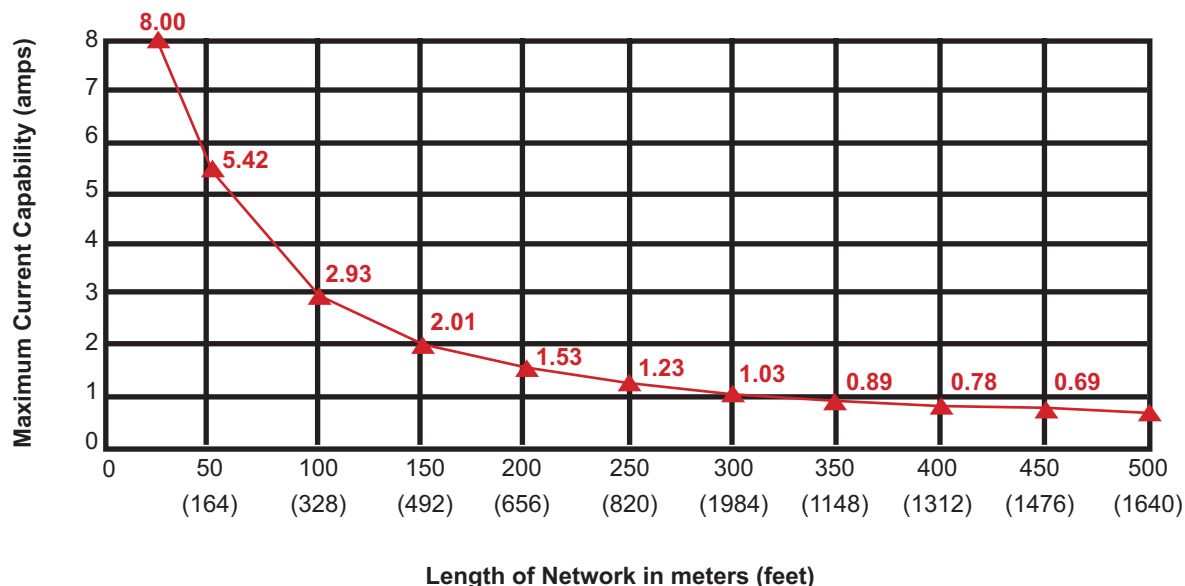

1.3.2 Thin Cable and Cable I

The maximum cable length used in trunk-drop topology, based on the data rate is:

Table V: Thin Cable and Cable I Topology

Communication Rate	Trunk Length	Maximum Drop	Cumulative Drop
125 kb	100 m (328 ft)	6 m (20 ft)	100 m (328 ft)
250 kb	100 m (328 ft)	6 m (20 ft)	78 m (256 ft)
500 kb	100 m (328 ft)	6 m (20 ft)	39 m (128 ft)

Thin Cable Capacity

Power distribution chart: Figure 2, shows the maximum allowed current through the power conductors of the thin cable. The distance is measured from a single 24 VDC power source. If the maximum current exceeds the specified value at any given point of the network, the power supply system should be re-designed. Figure 2 provides thin cable current ratings.

Figure 2: Current available through power conductors of thin cable

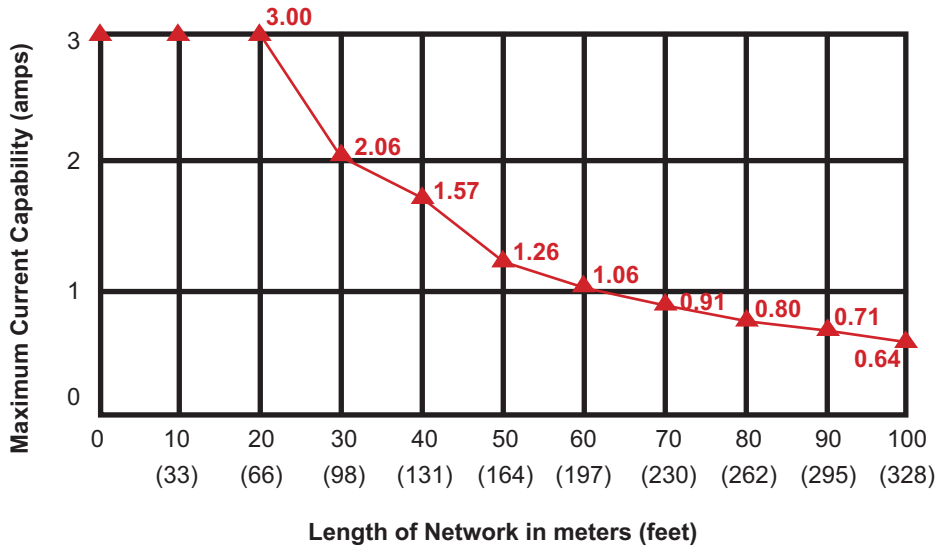

1.3.3 Flat Cable

The maximum flat cable length used in trunk topology, based on the data rate is:

Table VI: Flat Cable Topology

Communication Rate	Trunk Length	Maximum Drop	Cumulative Drop
125 kb	420 m (1378 ft)	6 m (20 ft)	156 m (512 ft)
250 kb	200 m (656 ft)	6 m (20 ft)	78 m (256 ft)
500 kb	100 m (328 ft)	6 m (20 ft)	39 m (128 ft)

Flat Cable Capacity

Figure 3: Current available through power conductors of flat cable

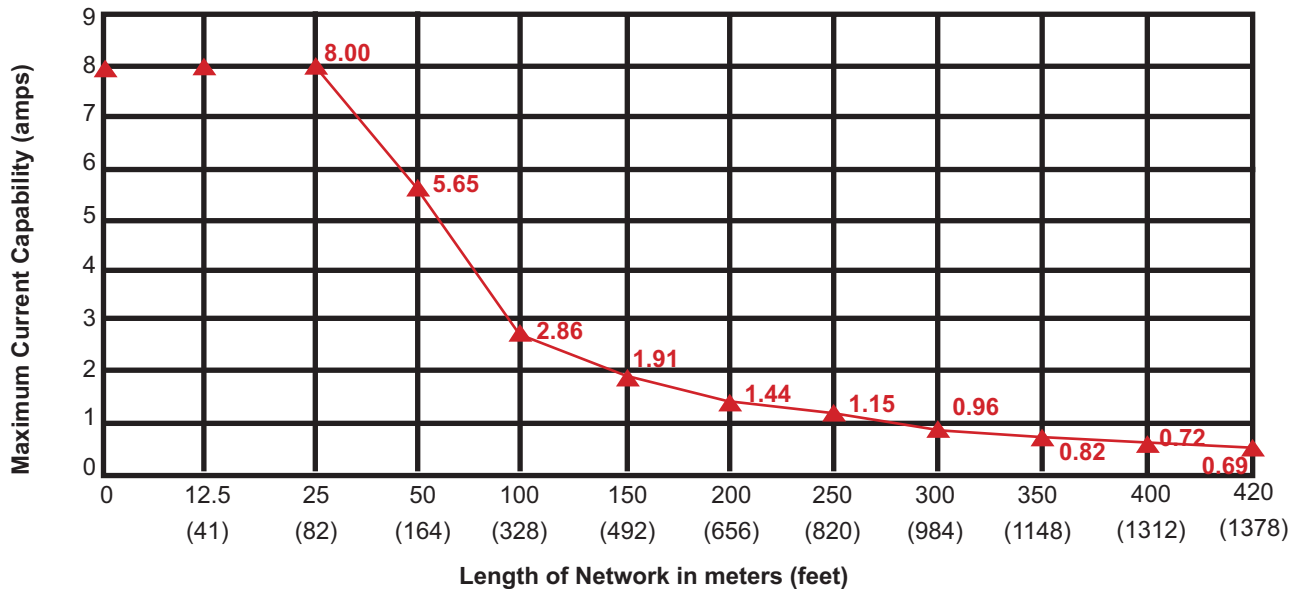

2. Quick Start

2.1 Know the Network Layout

An essential part of the troubleshooting process is knowing the layout of the network. Survey the network to determine the location (or existence) of these components.

2.1.1 Network Topology

- The trunk cable connects nodes and taps. Look for a terminating resistor at each end.
- The drop lines are the non-terminated cables that connect nodes to the trunk.

2.1.2 Location of Nodes

- Count the nodes and note their location on the network.

2.1.3 Location of Power Supplies

- There may be more than one power supply on a network, located at the end, middle, or anywhere along the cable. Only one of the power supplies must be the grounding point for network power.

2.2 When Things Go Wrong

The first question is always “What has changed?” If you have added or replaced nodes, changed wiring, or configured a scanner, start to look for a problem where you were working. If you cannot find a problem there, you will need to determine if the problem is caused by the physical media, a node communication fault, or the network power distribution.

It is sometimes difficult to determine the root problem, because there can be more than one network problem. In general, check for physical media and node configuration problems before network power distribution or isolating node communication faults.

2.2.1 Symptoms of Physical Media Problems

For This Symptom	Take This Action	See Procedure
All nodes on a trunk segment or on a drop stop communicating then may recover or go bus-off.	Check all wiring and connectors on the segment between the power supply and the terminating power.	3.1
Nodes sporadically stop communicating, and then recover.	Check for loose wiring or a loose connector leading to the node.	3.1, 3.2, 3.3
The network communicates only when the number of nodes or trunk length is reduced.	Check the resistance between conductors on the bus cable, CAN DC resistance, and terminating resistor values.	3.3

2.2.2 Symptoms of Node Problems

For This Symptom	Take This Action	See Procedure
Slave node is on-line, but the scanner says it does not exist.	Change the slave node address to match scanner's scan list.	3.6
Slave node will not go on-line.	Check CANH/CANL wiring.	3.4
	Change the slave node data rate to match the scanner's data rate.	4
The network communicates only when the node is removed.	Check the node's CAN transceiver.	3.4, 3.5
The node is in the I/O timeout state.	Reset the scanner and network power.	3.4

2.2.3 Symptoms of Network Power Distribution Problems

Network power distribution problems often produce sporadic or intermittent network failures.

For This Symptom	Take This Action	See Procedure
Nodes near the end of the trunk stop communicating after operating normally.	Check the bus voltage at the node and the common mode voltage at the ends of the bus.	3.3 - 3.4
The scanner or multiple nodes go to the bus-off state after operating normally.	Check common mode voltage and power supply/shield grounding.	3.2 - 3.3
The scanner does not detect properly configured slave nodes.	Check power supply/shield grounding and common mode voltage.	3.2 - 3.3
The network communicates only when the number of nodes or the trunk length is reduced.	Check the bus voltage at the node and the common mode voltage at the ends of the bus.	3.2

2.2.4 Network Failure

Network cannot go on-line, Bus-off condition (error 91).

For This Symptom	Take This Action	See Procedure
Cannot Start the Network.	Check bus voltage at node and common mode voltage at ends of bus.	3.3 - 3.4
	Check each node for Data Rate setting.	4
	Check each node for CAN transceiver failure.	3.5
	Check open style and field wireable connectors for proper wiring.	3.1

3. Network Tests

3.1 Termination Test

Description	Termination is used to match the impedance of a node to the impedance of the transmission line being used. When impedances are mismatched, the transmitted signal is not completely absorbed by the load and a portion is reflected back into the transmission line. If the source, transmission line and load impedance are equal, these reflections are eliminated. This test measures series resistance of DeviceNet™ data pair conductors and attached terminating resistors.	
Procedure	1) Turn all network power supplies off. 2) Measure and record DC resistance between CANH and CANL at the middle and end of the network.	
If Measured Values are:	<50 Ohms	Check for more than two terminating resistors. Check for short-circuit between CANH and CANL wiring. Check nodes for faulty transceivers (refer to CAN Transceiver Resistance Test).
	60 Ohms	Normal - do nothing.
	71-121 Ohms	Check for open circuits in CANH or CANL wiring. Check for one missing terminating resistor.
Problem Resolution	<ul style="list-style-type: none"> • Split the network down the middle into two segments. • Check resistance of each segment - should be 121 Ohm since only a single terminating resistor is present on each segment. • Mark a break point and leave it disconnected. • At least one segment will show resistance = to 121 Ohm. • Split a bad segment into two sections and add, temporarily, a terminating resistor to the non-terminated section. Mark the location of the break point and temporary terminating resistor. • Check the resistance of each section - should be 121 Ohm. • Continue splitting the network until the problem is located and repaired. • Remove all temporary resistors and bring network back to original state. • Verify once again that the assembled network has 60 Ohm resistance. 	

The same procedure is used to locate connector shorts or faulty transceivers.

3.2 Power Supply Ground Test

Description	The shield and V- of the DeviceNet™ cable system must be grounded at a single location as shown in Figure 4, preferably near the physical center of the network. If multiple power supplies are present, ground only at the power supply closest to the middle of the network. This test will indicate if multiple grounds are connected.	
Procedure	<ol style="list-style-type: none"> 1) Turn off all network power supplies. 2) Disconnect V- and Shield wires are from earth ground and from each other. 3) Measure and record the DC resistance between Shield and earth ground at the far most ends of the network. 4) Connect the V- and Shield wires to earth ground. 	
If Measured Values are:	<1 M Ohm	Check for additional grounded V- or Shield wires
	>1 M Ohm	Normal Range
Note:	Grounding wire could be up to 10-ft long. Grounding is done with: <ul style="list-style-type: none"> • 1" copper braid, or • #8 AWG copper wire up to 10-ft long 	

Figure 4: Network Grounding

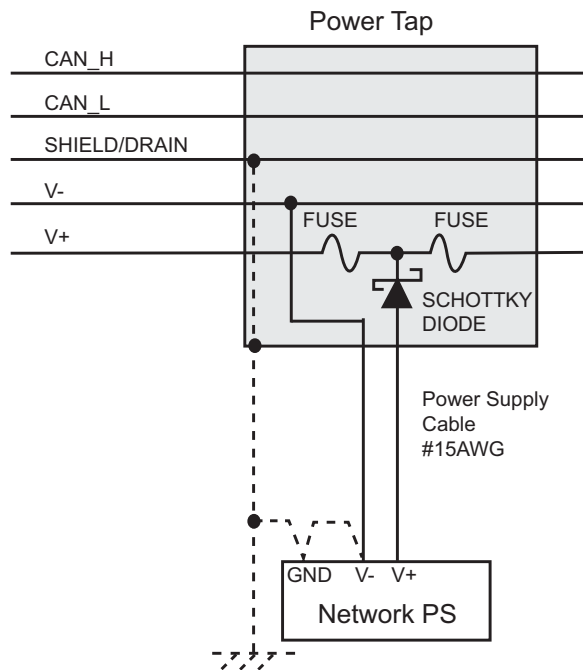

3.3 Power Common Mode Voltage Test

Description	When the current is drawn through the power pair on the DeviceNet trunk line, the resistance of the power pair conductors produces the common mode voltage drop. The effect of the common mode voltage is that the V+ line decreases from the 24 VDC at the power supply as you move farther from the power supply. More significantly, the V- line increases from the 0 VDC value at the power supply along the length of the trunk line. This test assumes that V+ decreases and V- increases are equal. Since CANH and CANL both are referenced to the V- wire, if the voltage on the V- line varies more than 4.65 VDC at any two points the CAN transceivers will fail to operate properly.	
Procedure	<ol style="list-style-type: none"> 1) Turn all network power supplies on. 2) Configure all nodes for their maximum current draw from network power. Turn on outputs that use network power. 3) Measure and record DC voltage between V+ and V- where each power supply connects to the trunk. 4) Measure and record DC voltage between V+ and V- at the ends of the network. 	
If the <u>difference</u> between any two measured values is:	<9.3 Volts	Normal Range
	>9.3 Volts	Network will not operate properly. Possible solutions: <ul style="list-style-type: none"> • Shorten overall length of the network cable • Move power supply in direction of overloaded section • Move nodes from overloaded section to less loaded section • Move high current loads close to the power supply • Add a second power supply • Break the network into two separate networks

3.4 CANH/CANL Voltage Test

Description	Each node contains a CAN transceiver that generates differential signals onto the data conductors. When the network communication is idle, the CANH and CANL voltages are approximately 2.5 volts. Faulty transceivers can cause the idle voltages to vary and disrupt network communication. Although this test indicates that faulty transceivers may exist on a network, it will not indicate which node has the faulty transceiver. If a node with a faulty transceiver is found, perform the CAN Transceiver Resistance Test.
Procedure	<ol style="list-style-type: none"> 1) Turn all network power supplies on. 2) Stop all network communication. 3) Measure and record the DC voltage between CANH and V- where the grounded power supply connects to the trunk. 4) Measure and record the DC voltage between CANL and V- where the grounded power supply connects to the trunk.

If CANH and/or CANL are:	<2/0 Volts	<ul style="list-style-type: none"> CANH/CANL conductor has intermittent short to shield or V-. Check all open style and field wireable connectors. Check CANH and CANL conductors for continuity. Possible faulty transceiver on one or mode nodes (refer to CAN Transceiver).
	2.0 - 3.0 Volts	Normal Range.
	>3.0 Volts	<ul style="list-style-type: none"> CANH/CANL conductor has intermittent short to V+. Network in bus-off state (error 91). Check all open style and field wireable connectors. Check for excessive common mode voltage (refer to Power Common Mode Voltage Test).
CAN Levels	Parameter	Range
Recessive	CANH	2.0 - 3.6
	CANL	2.0 - 3.6
	CANH - CANL	0.45 maximum
Dominant	CANH	2.75 - 5.1
	CANL	0.5 - 2.86
	CANH - CANL	0.95 minimum

3.5 CAN Transceiver Resistance Test

Description	The CAN transceivers used in DeviceNet™ nodes have one circuit that controls CANH and another circuit that controls CANL. Experience shows that electrical damage to one or both circuits may increase the leakage current in these circuits. This test uses an ohm/meter to measure the current leakage through the CAN circuits. Note: The reference values listed below are derived from tests with Philips Model PCA82C251 CAN transceivers and Fluke® multimeter Models 77 and 87. Other combinations of transceivers and multimeters may yield different results.	
Procedure 1	<ol style="list-style-type: none"> 1) Disconnect the node from the network. Leave the node unpowered. 2) Measure and record the DC resistance between CANH and V-. 3) Measure and record the DC resistance between CANH and V+. 4) Measure and record the DC resistance between CANL and V-. 5) Measure and record the DC resistance between CANL and V+. 	
If Measured Values are:	<1 M Ohms	Faulty CAN transceiver
	4 M - 6 M Ohms	Normal Range
	>6 M Ohms	Faulty CAN transceiver
Procedure 2	Measure resistance between CANH (signal probe) and CANL (common probe)	
If Measured Values are:	<36 Kohms	Faulty or deteriorated CAN transceiver
	36 > Kohms <39	Normal Range

3.6 ESD Discharge Test

Description	The following test shows if power and communication lines are affected by an electrostatic discharge. ESD may cause damage to the nodes and disrupt network communication. Every node is affected by discharge and in the long run most components will deteriorate, thus reducing network performance and reliability. A repeated node failure in the same production area indicates that an ESD discharge is above the components ratings. Transceiver PCA82C251 is rated for +/- 250 VDC ESD discharge, classification B, machine model: C=100 pF, R=0 Ohm. Tektronix® scope model THS730A, 200 Mhz, 1 GSs, or similar may be used for ESD test.	
Procedure 1	1) Connect Channel 1 to CANH and set voltage reference to 500 V. 2) Connect Channel 2 to CANL and set voltage reference to 500 V. 3) Set differential signal CANH - CANL. 4) Set time reference to 200 nsec. 5) Set trigger point at CH 1, at 250 V. 6) Measure voltage and adjust reference levels as required.	
If CANH Measured Values are:	<200 VDC >200 VDC	Acceptable ESD discharge Control systems must be grounded

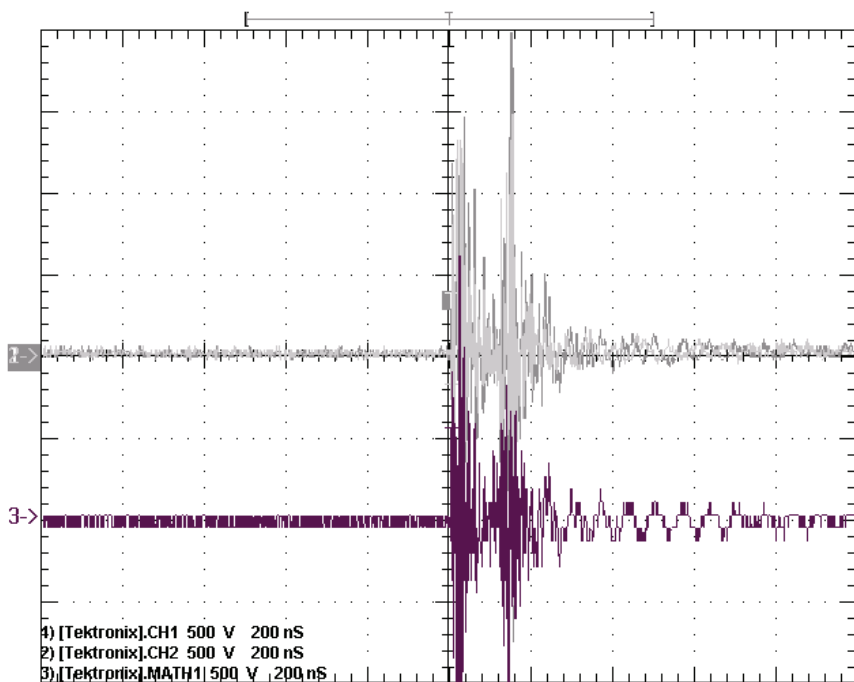

4. Setting Node Address and Communication Rate

The methods described below are used on TURCK and DeviceNet™ products and may be different than other vendors' implementations.

The default node address is 63 and the communication rate is set at 125 kbps (kilobits per second). The node address and communication rate parameters can be set in hardware or software. The factory default is Software Configuration. Changes to DIP switch settings take effect the next time the device is powered up or when the device receives a software reset.

4.1 Hardware Address/Comm Rate Configuration

Hardware configuration of node addresses and communication rates is accomplished using DIP switches located under the device cover. Switches S7 and S8 adjust the communication rate and switches S1-S6 set the node address using binary code. Switch S1 is the least significant bit and switch S6 is the most significant bit.

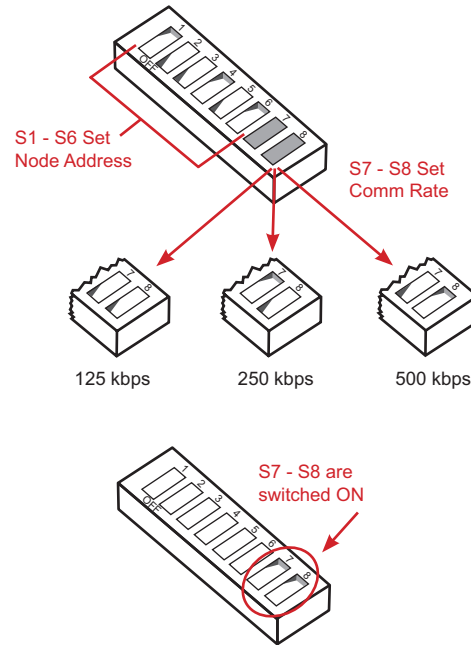

4.2 Software Address/Comm Rate Configuration

Software configuration of node addresses and communication rates is active when DIP switches S7 and S8 are ON. The node address and communication rates are stored in nonvolatile memory. Changes to the node address and communication rate require the use of a DeviceNet configuration tool. Switches S1-S6 are ignored when in software configuration mode.

4.3 Rotary Switches

Rotary switches provide a more convenient and reliable way of setting the node address or data rate.

The MSD (the Most Significant Digit) switch sets a tenth digit and the LSD (the Least Significant Digit) sets a single digit. The valid address range is 0-63.

The MSD switch set to the PGM (programmable) position allows use of node commissioning or software setup of the node address.

The Data Rate switch, when available, is used for the selection of a pre-defined communication speed. In "Auto" position, the node detects the Data Rate through "Autobaud". It usually takes several poll messages to be transmitted for the node to "lock" in the appropriate Data Rate. In addition to these four predefined positions, the Data Rate switch can be set to "PGM" (programmable mode). The PGM position is any non-predefined position.

Changes to the rotary switch settings take effect the next time the device is powered up or when the device receives a software reset.

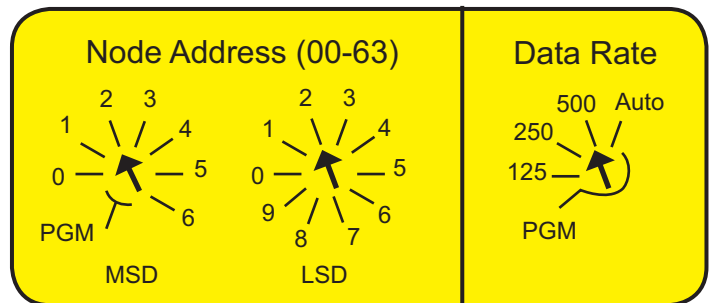

TURCK USA

TURCK Inc.
3000 Campus Drive
Minneapolis, MN 55441
Phone: (763) 553-7300
Fax: (763) 553-0708
Application Support:
1-800-544-7769

TURCK Mexico

TURCK MEXICO S. DE R.L. DE C.V.
Carr. Saltillo-Zacatecas km 4.5 s/n
Parque Industrial "La Angostura"
Saltillo, COAH. C.P. 25070
MEXICO
Phone: +52 (844) 411-6647/46
Fax: +52 (844) 482-6926
Toll free: 01-800-01-88725 (Mexico only)
E-mail: ventasmexico@turck.com

TURCK Canada

CHARTWELL
ELECTRONICS, INC.
140 Duffield Drive
Markham, Ontario
Canada, L6G 1B5
Phone: (905) 513-7100
Fax: (905) 513-7101
Toll Free: 1-877-513-7769

TURCK

World Headquarters

Hans TURCK GmbH & Co. KG
Witzlebenstrasse 7
D-45472 Muelheim an der Ruhr
Federal Republic of Germany
Phone: (+49) 208-49 52-0
Fax: (+49) 208-49 52 264

....Sense It!....Connect It!....Bus It!....Solve It!