



DIAGNOSTIC TROUBLESHOOTING GUIDE

Introduction

The Curtis Snowplow family of products are built and tested for lasting performance. All snowplows are fully tested for electrical, hydraulic and lighting malfunctions prior to shipping. Any malfunction is corrected immediately at our facility to ensure that our customers receive a quality product that will last for years to come. As with any piece of equipment, rough service and harsh environments can lead to poor performance, necessitating repairs.

When diagnosing snowplow malfunctions, it is important to methodically separate and test the different systems that are utilized on the Curtis Sno-Pro series snowplows. The approach detailed below will greatly reduce diagnostic time and take the guess work out of troubleshooting. What this means is lower associated labor, fewer unnecessary parts and more satisfied customers.

The following pages contain the hydraulic circuit as well as the electrical system. Each diagram shows a specific function, and what actually happens when a function is activated. The information will be useful in helping to understand what to look for when troubleshooting a snowplow malfunction. Each page, both electrical and hydraulic, has a "What Happens" heading at the top of the page. This will offer a step by step sequence of what takes place internally in the snowplow system once the controller is activated.

This will act as a guide to what to look for as a possible cause of a malfunction.

TABLE OF CONTENTS

Reference Section

Hydraulic Manifold Symbols	Page 1
Electrical System Symbols	Page 2
Sno-Pro 3000/Home-Pro Hydraulic Manifold Circuit	Page 3
Sno-Pro 2000/Trip Edge/Mach 1 Hydraulic Manifold Circuit	Page 4
Sno-Pro V-Plow W/SA Cylinders Hydraulic Manifold Circuit	Page 5
Electrical Plug Pin-Outs	Page 6
Electrical Plug Pin-Outs Continued	Page 7
Hydraulic Manifold Parts Breakdown	Page 8
Electric/Hydraulic Power Unit Parts Breakdown	Page 9
Notice & Warnings	Page 10
Diagnostic Method	Page 11-13

Function Guide Section: Sno-Pro 3000/Home-Pro

Angle Left Electrical	Page 14
Angle Left Hydraulic	Page 15
Angle Right Electrical	Page 16
Angle Right Hydraulic	Page 17
Plow Lift Electrical	Page 18
Plow Lift Hydraulic	Page 19
Plow Float Electrical	Page 20
Plow Float Hydraulic	Page 21
Jack Extend Electrical	Page 22
Jack Extend Hydraulic	Page 23
Jack Retract Electrical	Page 24
Jack Retract Hydraulic	Page 25
2010 Sno-Pro 3000 Elec/Hyd Overview	Page 26

Function Guide Section: Sno-Pro 2000/Trip-Edge/Commercial

Angle Left Electrical	Page 27
Angle Left Hydraulic	Page 28
Angle Right Electrical	Page 29
Angle Right Hydraulic	Page 30
Plow Lift Electrical	Page 31
Plow Lift Hydraulic	Page 32
Plow Float Electrical	Page 33
Plow Float Hydraulic	Page 34

Sno-Pro V-Plow with Single Acting Cylinders

Angle Left Electrical	Page 35
Angle Left Hydraulic	Page 36
Angle Right Electrical	Page 37
Angle Right Hydraulic	Page 38
Left Wing Extend Electrical	Page 39
Left Wing Extend Hydraulic	Page 40
Right Wing Extend Electrical	Page 41
Right Wing Extend Hydraulic	Page 42
Left Wing Retract Electrical	Page 43
Left Wing Retract Hydraulic	Page 44
Right Wing Retract Electrical	Page 45
Right Wing Retract Hydraulic	Page 46
Plow Lift Electrical	Page 47
Plow Lift Hydraulic	Page 48
Plow Float Electrical	Page 49
Plow Float Hydraulic	Page 50

Sno-Pro Poly Trip-Edge V-Plow

2010 Poly Trip-Edge V-Plow Elec/Hyd Overview	Page 51
Vehicle Side Schematic	Page 52
Plow Side Schematic	Page 53
Vehicle Side Harness Schematic	Page 54
Plow Side Harness Schematic	Page 55
Plow Side Straight Blade Adapter	Page 56
Plow Side V-Blade Blade Adapter	Page 57
Vehicle Side Relay Connector Plugging	Page 58

Troubleshooting Index

Troubleshooting Index by Problem	Pages 59-72
Curtis Warranty Forms	Page 73 - 74



CURTIS SNOWPLOWS: MANIFOLD SYMBOLS

Cross-Over Relief Valve

Usage: Angle Circuits

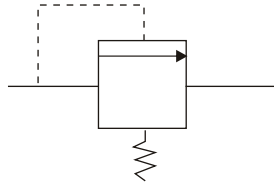

Flow Restrictor

Usage: Lift & Jack Circuit



Check Valve

Usage: Lift Circuit



2/2 Way Solenoid Valve

Usage: 1TBM2 Plow Float
1TBM2a Jack Retract

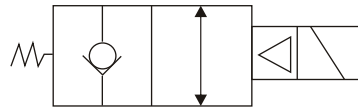

Filter Screen

Usage: All Circuits

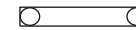

P

**Pressure Supply
From Power Unit**

3/4 Way Solenoid Valve

W/Tandem Center
Usage: 1TBM1 Angle Valve

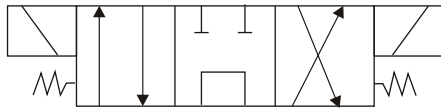

3/4 Way Solenoid Valve

W/Open Center
Usage: 1TBM7
Plow Lift/Jack Extend Valve

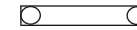
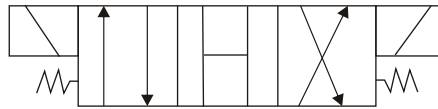

T

**Fluid Return to
Reservoir**

2/2 Way Solenoid Valve

W/Adjustable Rate
Usage: 1TBM2V V-Plow Float

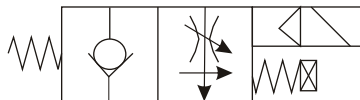

3/4 Way Solenoid Valve

Usage: 1TBM1V
V-Plow Wing Extend/Retract Valve

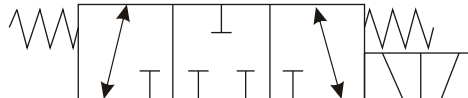

2/2 Way Solenoid Valve

Usage: 1TBM3
Trip Edge Lift Valve

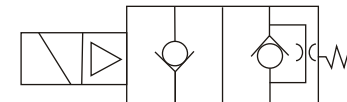

SNO-PRO / HOME-PRO: ELECTRICAL SYMBOLS & DIAGRAMS

Chassis Ground

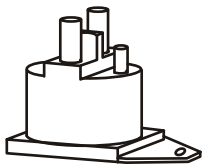

Pump Motor Solenoid
Curtis Part #: 1TBP61A

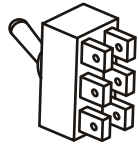

Plow Light Switch
Curtis Part #: 1TBP48A

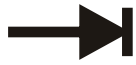

Diode



15a Fuse

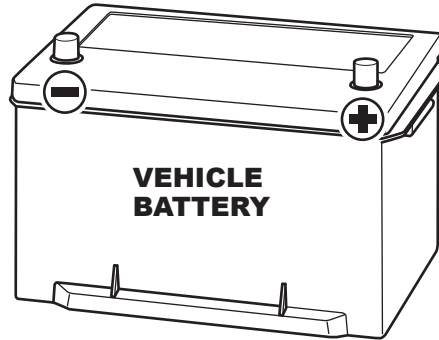

Jack Switch
Curtis Part #: 1TBP100

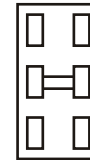

Switch Panel Control Kit
Curtis Part #: 1TBP60A

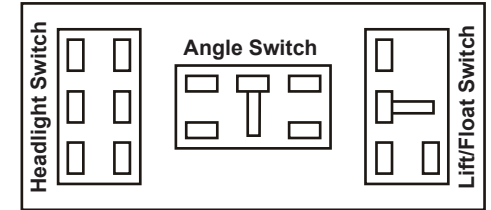

Note: Lift/Float Switch, Angle Switch & A-Frame Jack Switch all have bridged center terminals conducting power to both poles of the switch.

Electric/Hydraulic Power Unit
With Manifold Block

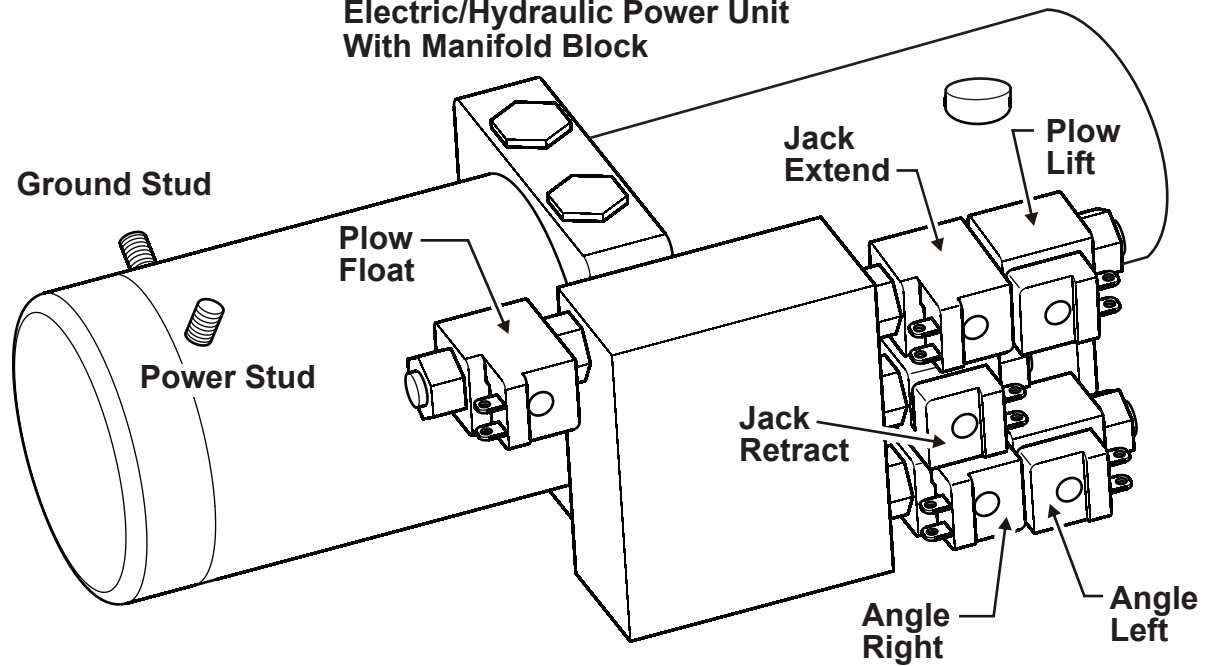

SNO-PRO / HOME-PRO / TRIP-EDGE w/HYD.JACK: MANIFOLD CIRCUIT - HYDRAULIC

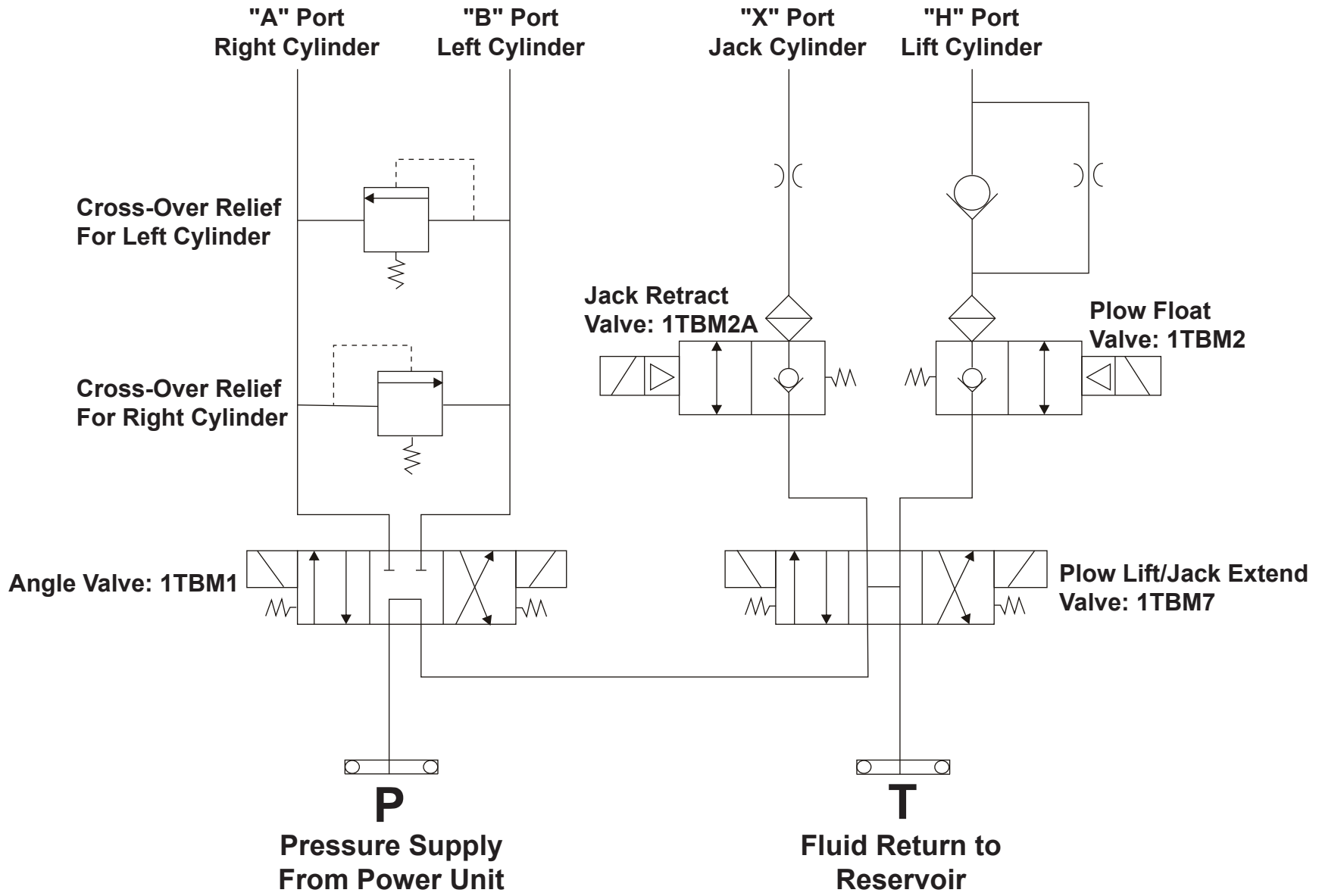

SNO-PRO TRIP EDGE w/GAS SPRING JACK & SNO-PRO 2000 MANIFOLD CIRCUIT - HYDRAULIC

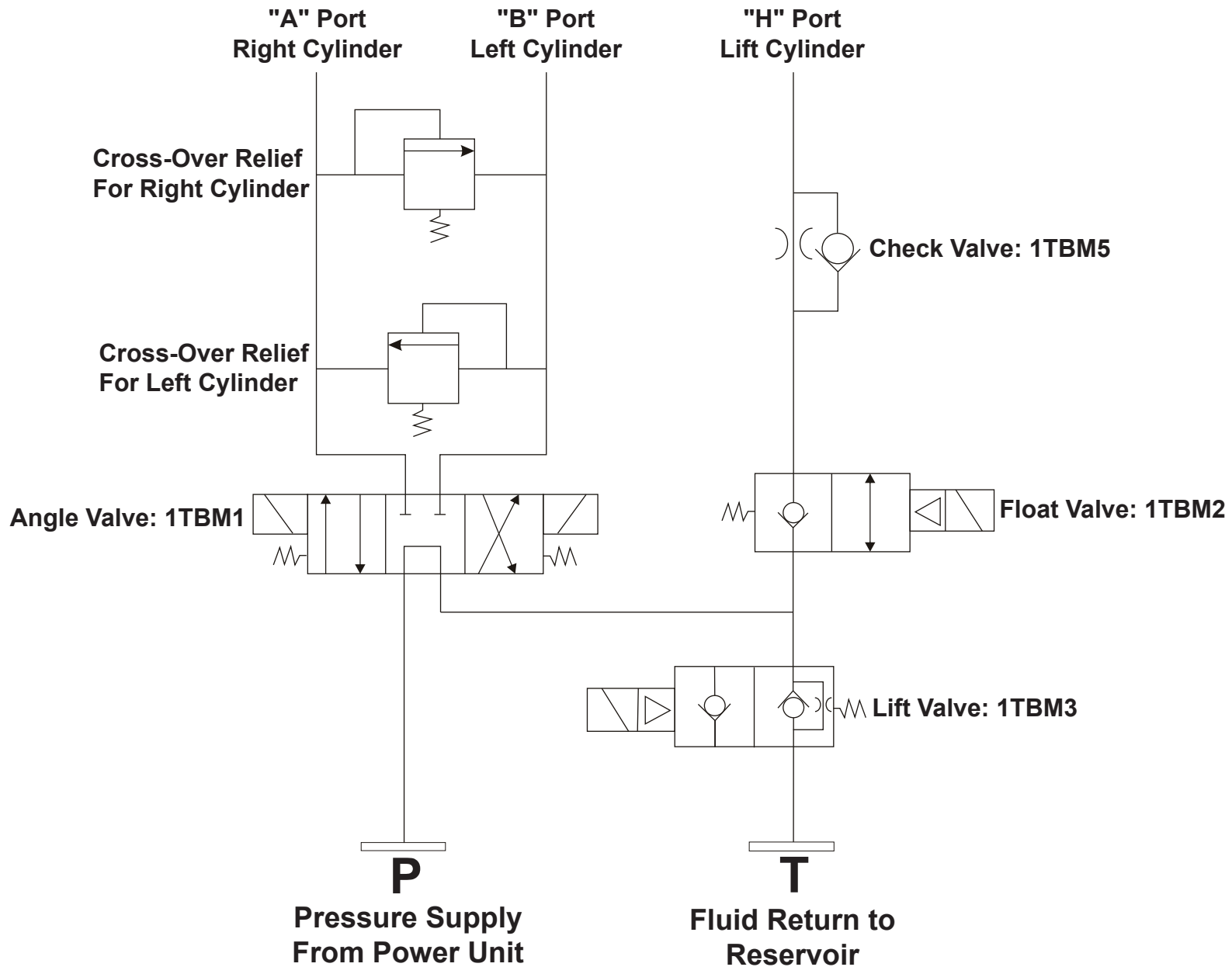

SNO-PRO/V-PLOW w/SINGLE ACTING CYLINDERS & SPRING RETURN: MANIFOLD CIRCUIT - HYDRAULIC

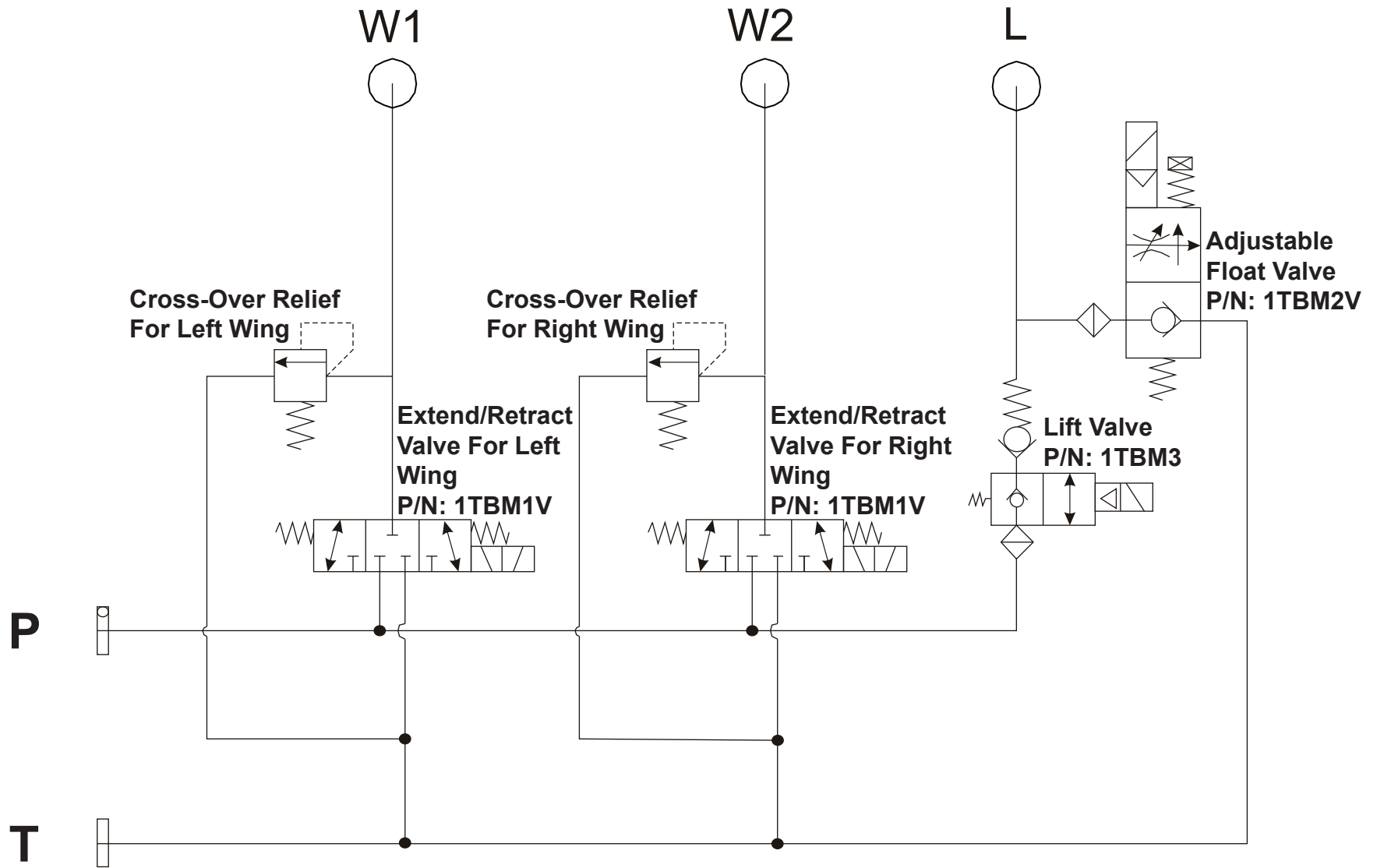

SNO-PRO / HOME-PRO / TRIP-EDGE w/HYD. JACK: ELECTRICAL PLUG PIN-OUTS

Single Plug Harness Vehicle Side Harness

CURTIS PLUG (90-2010-00)			
(LG/B = LT GREEN / BLACK) (Y/B = YELLOW / BLACK)			
PIN #	COLOR	FUNCTION	AWG
1	BLACK	GROUND	4
(1)	ORANGE	GROUND	18
2	RED	12 VDC (+)	4
3	GREEN	FLOAT	18
4	RED	LIFT	18
5	BLUE	LEFT SOLENOID	18
6	WHITE	RIGHT SOLENOID	18
7	BROWN	PUMP SOLENOID	16
8	WHITE/RED	LIGHT COMMON	16
9	LG/B	LOW BEAM	16
10	Y/B	HIGH BEAM	16
11	GRAY	PARK / RUN	18
12	VIOLET	LEFT TURN	18
13	PINK	RIGHT TURN	18
14	NA	NA	NA

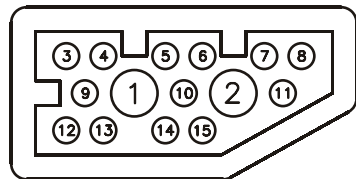

END VIEW
LOOKING AT
CONNECTOR

Single Plug Harness Plow Side Harness

CURTIS PLUG (90-2011-00)			
(LG/B = LT GREEN / BLACK) (Y/B = YELLOW / BLACK)			
PIN #	COLOR	FUNCTION	AWG
1	BLACK	GROUND	4
(1)	ORANGE	GROUND	16
2	RED	12 VDC (+)	4
3	GREEN	FLOAT	18
4	RED	LIFT	18
5	BLUE	LEFT SOLENOID	18
6	WHITE	RIGHT SOLENOID	18
7	BROWN	PUMP SOLENOID	16
8	WHITE/RED	LIGHT COMMON	16
9	LG/B	LOW BEAM	16
10	Y/B	HIGH BEAM	16
11	GRAY	PARK / RUN	18
12	VIOLET	LEFT TURN	18
13	PINK	RIGHT TURN	18
14	NA	NA	NA
15	NA	NA	NA

END VIEW
LOOKING AT
CONNECTOR

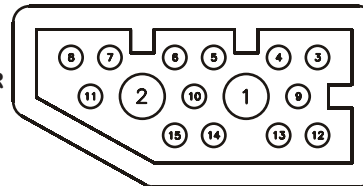

Double Plug Harness Control Plug

PIN #	COLOR	FUNCTION	AWG
1	ORANGE	GROUND	16
2	GREEN	FLOAT	18
3	RED	LIFT	18
4	BLUE	LEFT SOLENOID	18
5	NONE		
6	WHITE	RIGHT SOLENOID	18
7	BROWN	PUMP SOLENOID	16
8	WHITE/RED	LIGHT COMMON	16
9	GRN/BLK	LOW BEAM	16
10	NONE		
11	YEL/BLK	HIGH BEAM	16
12	GRAY	PARK / RUN	16
13	VIOLET	LEFT TURN	18
14	PINK	RIGHT TURN	18
15	NONE		

Plow Side Vehicle Side

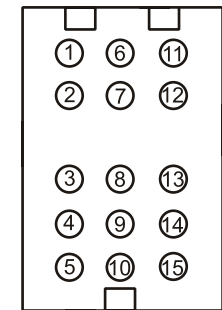
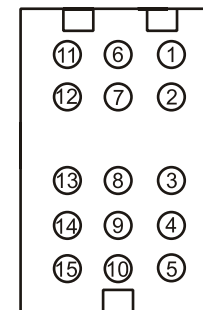

SNO-PRO / HOME-PRO / TRIP-EDGE w/HYD. JACK: ELECTRICAL CONNECTIONS

In-Cab Control Plug

"MOLEX" FREE HANGING RECEPTACLE
.093 (9) PIN POWER CONNECTOR
P/N 03-09-1094
WITH "MOLEX" FEMALE TERMINAL
P/N 02-09-1117

PIN #	COLOR	FUNCTION
1	BLACK	12v +
2	BLUE	LEFT
3	WHITE	RIGHT
4	RED	LIFT
5	GREEN	FLOAT
6	BROWN	PUMP SOLENOID
7	ORANGE	GROUND -
8	NA	NA
9	NA	NA

END VIEW
LOOKING AT
CONNECTOR

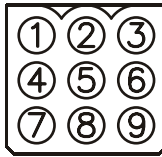

Vehicle Side Harness Headlight Adapter Connectors

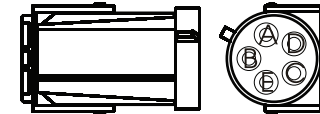

A= WHT/RED	COMMON
B= YEL	HIGH BEAM FEED
C= LT GRN	LOW BEAM FEED
D= YEL/RED	HIGH BEAM
E= GRN/RED	LOW BEAM

In-Cab Headlight Switch Connections

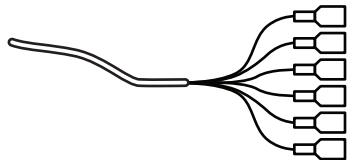

COLOR	FUNCTION
GREEN	LOW BEAM FEED
YELLOW	HIGH BEAM FEED
GREEN/BLACK	LOW BEAM PLOW
YELLOW/BLACK	HIGH BEAM PLOW
GREEN/RED	LOW BEAM VEHICLE
YELLOW/RED	HIGH BEAM VEHICLE

Plow Side Harness Headlight Connector

.180 BULLET TERM.
M = MALE
F = FEMALE

END VIEW
LOOKING AT
CONNECTOR

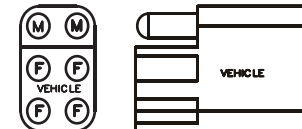

A = COMMON (WHITE/RED)
B = NOT USED
C = TURN (PINK) OR (VOLET)
D = RUN (GRAY)
E = LOW BEAM (L. GREEN/BLACK)
F = HIGH BEAM (YELLOW/BLACK)

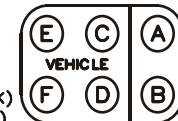

SNO-PRO / HOME-PRO / TRIP-EDGE w/HYD. JACK: HYDRAULIC MANIFOLD

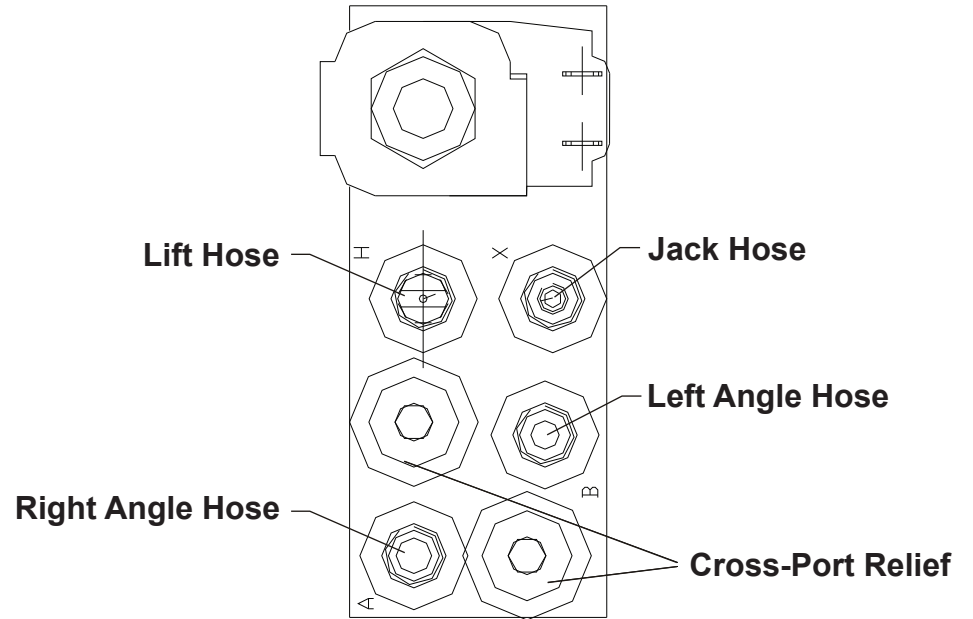
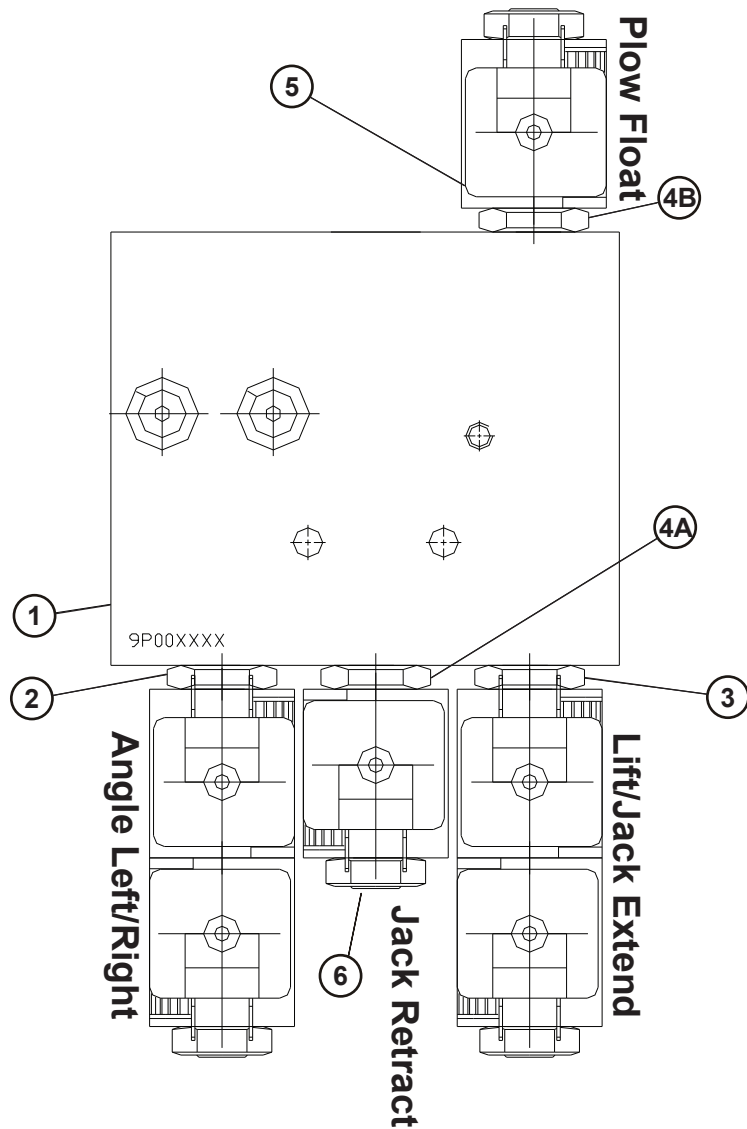

Schem. Ref #	Item Part #	Recommend Dealer Stock	Description	Qty/ Unit
1	1TBP59AP2		Manifold Block Complete With Valves & Coils	1
2	1TBM1	*	3/4 WAY SOLENOID VALVE (ANGLE LEFT/RIGHT)	1
3	1TBM7	*	2/2 WAY SOLENOID VALVE (PLOW LIFT)	1
4	1TBM2	*	2/2 WAY SOLENOID VALVE (PLOW FLOAT)	1
5	1TBM4	*	12 VDC COIL	6
6	1TBM2A	*	2/2 WAY SOLENOID VALVE (JACK RETRACT)	1

SNO-PRO / HOME-PRO / TRIP-EDGE w/HYD. JACK: HYDRAULIC POWER UNIT

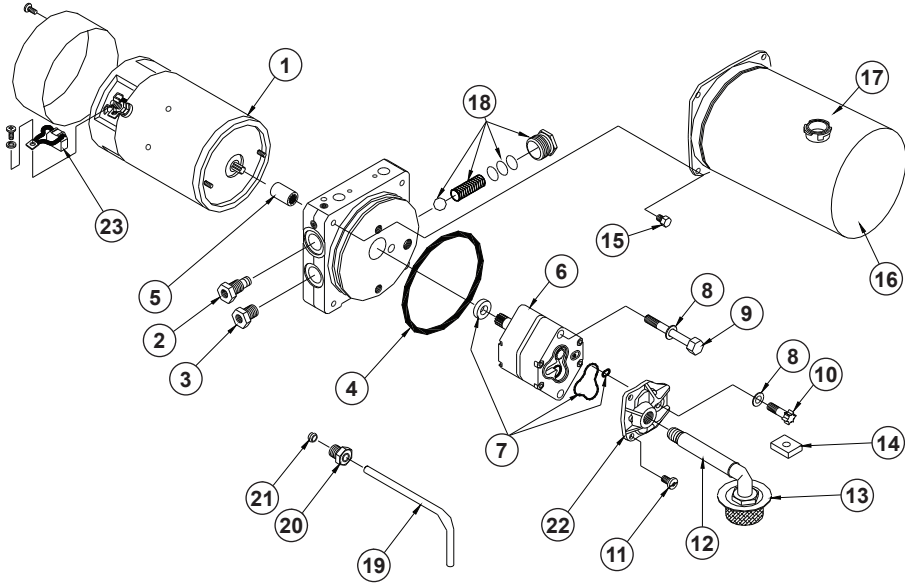

Schem. Ref #	Item Part #	Recommend Dealer Stock	Description	Qty/ Unit
Sno-Pro Hydraulic Power Unit Parts Breakdown				
N/S	1TBP59AP1		ELEC/HYD POWER UNIT W/O MANIFOLD	1
1	1TBM8	*	DC MOTOR 12V	1
2	1TBM9		VALVE PLUG	1
3	1TBM10		VALVE PLUMBING PLUG	1
4	1TBM11	*	RESERVOIR O-RING	1
5	1TBM12		COUPLING	1
6	1TBM13		PUMP ASSEMBLY	1
7	1TBM14		PUMP O-RING KIT	1
8	1TBM15		WASHER FLAT	1
9	1TBM16		PUMP MOUNTING BOLT	2
10	1TBM17		BOLT - SUCTION COVER 5/16"	1
11	1TBM18		SCREW TAPTITE M6 X 12mm	1
12	1TBM19		PLUMBING ASSEMBLY INLET	1
13	1TBM20	*	FILTER	1
14	1TBM21	*	COLLECTOR MAGNET	1
15	1TBM22		RESERVOIR SCREW	4
16	1TBM23V	*	RESERVOIR	1
17	1TBP63A	*	EXTERNAL RESERVOIR BREATHER CAP	1
N/S	1TBP63B	*	INTERNAL RESERVOIR BREATHER CAP	1
18	1TBM25		FIXED RELIEF VALVE ASSEMBLY	1
19	1TBM26		RETURN TUBE	1
20	1TBM27		COMPRESSION NUT	1
21	1TBM28		COMPRESSION SLEEVE	1
22	1TBM29		SUCTION COVER	1

Schem. Ref #	Item Part #	Recommend Dealer Stock	Description	Qty/ Unit
KTI Hydraulic Power Unit Parts Breakdown				
N/S	1TBP59AP1V		ELEC/HYD POWER UNIT W/O MANIFOLD	1
1	1TBM8A	*	DC MOTOR 12V	1
2	1TBM13A		Gear Pump	1
3	1TBM12A		Motor to Pump Coupling	1
4	1TBM35		5/16" x 3" Pump Mounting Bolts	2
5	1TBM36		3/8" NPT Plastic Elbow	1
6	1TBM20	*	3/8" NPT Inlet Strainer	1
7	1TBM37	*	Cartridge Relief Valve	1
8	1TBM23A	*	Steel Reservoir	1
9	1TBM11A	*	Reservoir O-Ring	1
10	1TBM21	*	Collector Magnet	1
11	1TBM38		1/4" NPT Adapter	1
12	1TBM39		1/2" ID Clear Plastic Tubing	1

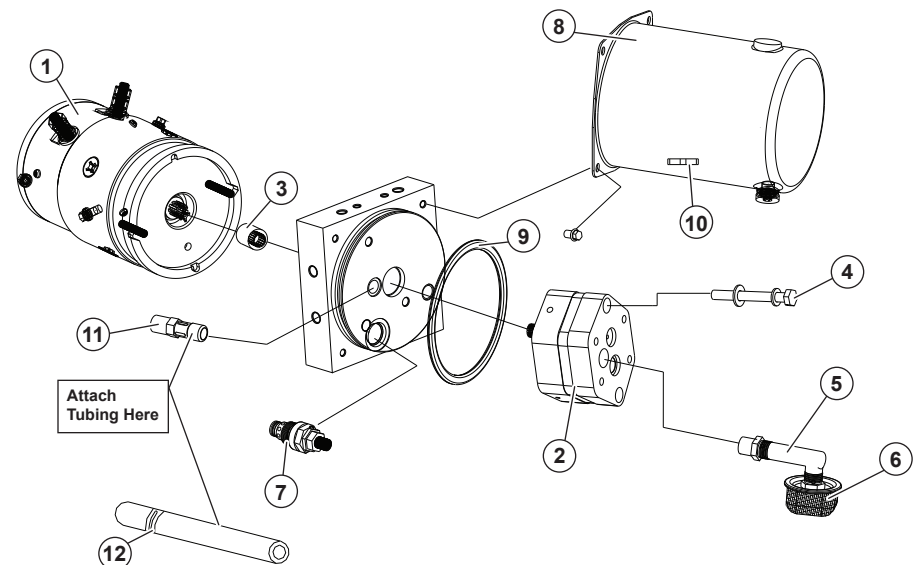

SNO-PRO / HOME-PRO / TRIP-EDGE w/HYD.JACK TROUBLESHOOTING GUIDE

⚠ NOTICE

⚠ Know your own abilities and mechanical skills. Some procedures in the following Troubleshooting Guide require a considerable mechanical aptitude. Use discretion and refer to an Authorized Curtis Dealer when needed.

The following Guide has been developed to provide a step-by-step approach to Troubleshooting operational problems with your Sno-Pro/Home-Pro 3000 Snow Plow.

Many functional problems may be solved by first following this General Checklist.

- Remove the Filler Cap on the Pump and verify the Reservoir is full of oil.
- Check for external leaking and tighten any loose Hoses, Fittings, or Plugs. Damaged Hoses must be replaced immediately.
- Check the condition of the Fuse, replace if necessary.
- Check the Harness Plug Connector at the front of the vehicle and verify a good connection.
- Check the Wire Connectors at the Switch Panel Control or Joystick Control and verify the Wire Leads are secure.
- Check the Battery and Solenoid connections under the hood of the vehicle and verify a good connection and ground.
- Remove the A-Frame Cover and verify a good ground connection.

If functional problems persist after following the General Checklist, locate the description of the problem you are experiencing in the Troubleshooting Guide Glossary and follow the course of action detailed under the specific problem.

Suggested Test Equipment:

An Analog 8-Range Multimeter, which can measure DC voltage up to 20 Volts, is preferred for any of the tests described in z Guide.

Most tests can be performed using a 12vdc-Test Light and/or Continuity Tester.

A 3000-PSI Oil Filled Pressure Gauge will be needed for some of the Hydraulic test procedures.

DIAGNOSTIC METHOD - FIND THE PROBLEM....FAST!

System #1: Vehicle Electrical System:

Related Components: **Vehicle Side Wiring Harness**
 Battery Lead #4 Gauge
 Motor Solenoid
 In-Cab Control
 Headlight Switch
 Headlight Adapter

The starting point for this method is the Vehicle Side Electrical System. The chart below details all of the Plug Pinouts for the Vehicle Side Harness.

The very first step in this process is to verify a PROPER INSTALLATION i.e. In-Cab Control plugged in and turned on, all wires connected correctly, good ground connections, etc...

Testing Plow Functions:

Using the diagram below and a test light, activate each function and test the corresponding pin in the Harness Plug for power. For Lift, Left Angle & Right Angle functions, the Pin for each function AND the Pin for the Pump Solenoid should be powered at the same time. Activating the Pump Solenoid will also power the 12vdc Hi-Amp Pin (#2). When testing the float function, only that Pin will be powered. For testing Headlight and Directional functions, it will be necessary to turn each function on inside the cab. If all Pins test correctly, the Vehicle Harness System has been eliminated as the cause of the malfunction. If one or more Pins do not test correctly, determine which device is connected at the other end of the Harness.

For function problems, test the In-Cab Controls. To do this, attach the test light alligator clip to ground and insert the probe of the test light into the colored wire on the in-cab control that corresponds with the function that is being tested. Activate the function and test for power. Through the process of elimination, the In-Cab Control will be determined faulty or in good working order.

DIAGNOSTIC METHOD - FIND THE PROBLEM....FAST!

If all functions test correctly but no power is being sent to the 12vdc Hi-Amp (Pin #2), test the Brown Wire at the Pump Solenoid. To do this, activate each function (Lift, Left, Right) and test the Brown Wire connection at the Solenoid with the Test Light. If no power is present, the Harness may be faulty.

If power is present but the Solenoid is not operating, double check the Battery Cable connections as well as the mounting surface. The Pump Solenoid grounds through the Mounting Bracket and must have a rust-free, metallic surface to mount to. If the above has been checked, the Solenoid is faulty. If the Solenoid is transferring voltage from one terminal to the other when activated, the Solenoid is working properly and there may be an internal malfunction in the Harness.

Testing Plow Light System: For lighting problems, test the Plow Light Switch first. Turn the vehicle headlights on. Locate the Plow Headlight Switch and test each wire for power depending on the position of the Switch. If the Switch toggles between vehicle and plow lights properly, disconnect the Headlight Adapters one side at a time and test the Gray Packard Connectors for power. See the diagram below for details. If all of the functions test properly, the Vehicle Harness is in proper working order. Otherwise, there is an internal malfunction in the Harness.

If, after performing the above test procedures, the Vehicle Harness is working properly, remove the A-Frame Cover from the Plow and plug the Plow Harness into the Vehicle Harness. It is not necessary to re-attach the Plow to the vehicle as this reduces the work area. It may be necessary, however, to remove the Harness P-Clamp from the Lift Frame Upright and remove the Wire Ties holding the Headlight pigtails. This will increase the Harness length.

System #2: Plow Electrical System:

Related Components: Plow Side Wiring Harness
12vdc Valve Coils
Plow Lights
12vdc Pump Motor

The next step in the testing procedure is to determine if the Plow Side Harness is working properly.

Testing Plow Functions:

WARNING: DISCONNECT THE POSITIVE BATTERY CABLE FROM THE BATTERY SIDE OF THE PUMP MOTOR SOLENOID BEFORE TESTING THE PLOW SIDE HARNESS. IF THIS IS NOT DONE, THE PLOW MAY MOVE ERRATICALLY DURING THIS TEST. FAILURE TO DO SO MAY RESULT IN SERIOUS INJURY OR DEATH.

DIAGNOSTIC METHOD - FIND THE PROBLEM....FAST!

Testing Plow Functions: Disconnect the Packard Connector for the function to be tested. The Table below indicates the Color Code for each function. Connect the alligator clip of the test light to a ground source (the stud on the back of the Pump Assembly). Insert the test probe into the colored side of the Packard Connector (the Orange Wire side is used for a ground connection) and activate the function. Remember, Lift, Left Angle & Right Angle functions also activate the Pump Motor (Brown Wire) simultaneously. If the Packard Controller is receiving power when the function is activated, the Plow Side Harness is working properly.

Testing Plow Light System: For Headlight testing on the Plow, disconnect the Plow Light pigtail from the Harness and, using the Table below, test for Light functions, i.e. Hi-Beam, Lo-Beam, Common, Parking Lights and Directional Lights. If the functions are receiving voltage, the Plow Harness is working properly and there may be a malfunction within the Plow Headlight Assembly. If the functions are not receiving voltage, there may be an internal malfunction in the Plow Side Harness.

Testing 12vdc Valve Coils: Leave the Battery side of the Pump Motor Solenoid disconnected from the Battery. Remove the 12vdc Coil from the Valve for the function to be tested. Insert the probe of the test light through the hole in the Coil. Activate the function using the In-Cab Control. A magnetic draw from the Coil should pull the test probe when energized. If no draw is present, the Coil may be faulty. If the 12vdc Valve Coils are working properly, the function problem is most likely a Hydraulic problem.

System #3: Snowplow Hydraulic System:

Related Components: Electric/Hydraulic Power Unit Hydraulic Manifold

After it has been determined that both the Vehicle Side and Plow Side Harnesses are in proper working order, the next step will be to troubleshoot the Hydraulic System, with particular attention to the Manifold.

The main function of the Hydraulic Manifold is to direct fluid to the appropriate Cylinder to perform a task. For Example: When the In-Cab Control is moved to the 'Plow Lift' function, the Pump Motor spins the Pump developing pressure. This pressure enters the Manifold. The Manifold's internal plumbing is configured in such a way that if no Valve is opened, the fluid will return to the Reservoir on the Electric/Hydraulic Power Unit. Activating the 'Plow Lift' function not only engages the Pump, but also shifts the 'Plow Lift/Jack Extend' Valve to the 'Plow Lift' position. The pressurized fluid will follow the path of least resistance, in this case, the opened 'Plow Lift' passageway. The fluid then exits the Manifold through the 'Lift' Hose attached to the 'H' Port on the Manifold and the 7-1/2" Lift Cylinder at the other end. Pressurized fluid extends the Lift Cylinder raising the Plow. Read through the following pages for detailed Hydraulic and Electrical Circuit information.

SNO-PRO / HOME-PRO / TRIP-EDGE w/HYD. JACK: ANGLE LEFT FUNCTION - ELECTRICAL

What Happens:

- A.) Ignition 'On' energizes the Controller Power source sending 12vdc into the Controller. If equipped with a Joystick or Touch Pad, the Controller Power Switch must be in the 'On' position.
- B.) Moving the Controller to 'Angle Left' position energizes the Blue 'Angle Left' Wire and the Brown 'Solenoid' Wire.
- C.) The Brown 'Solenoid' Wire closes the Solenoid Contacts and sends 12vdc power to the Pump Motor.
- D.) The Blue 'Angle Left' Wire sends 12vdc power to the Angle Left Valve Coil.
- E.) See next page for Hydraulic Flow Chart.

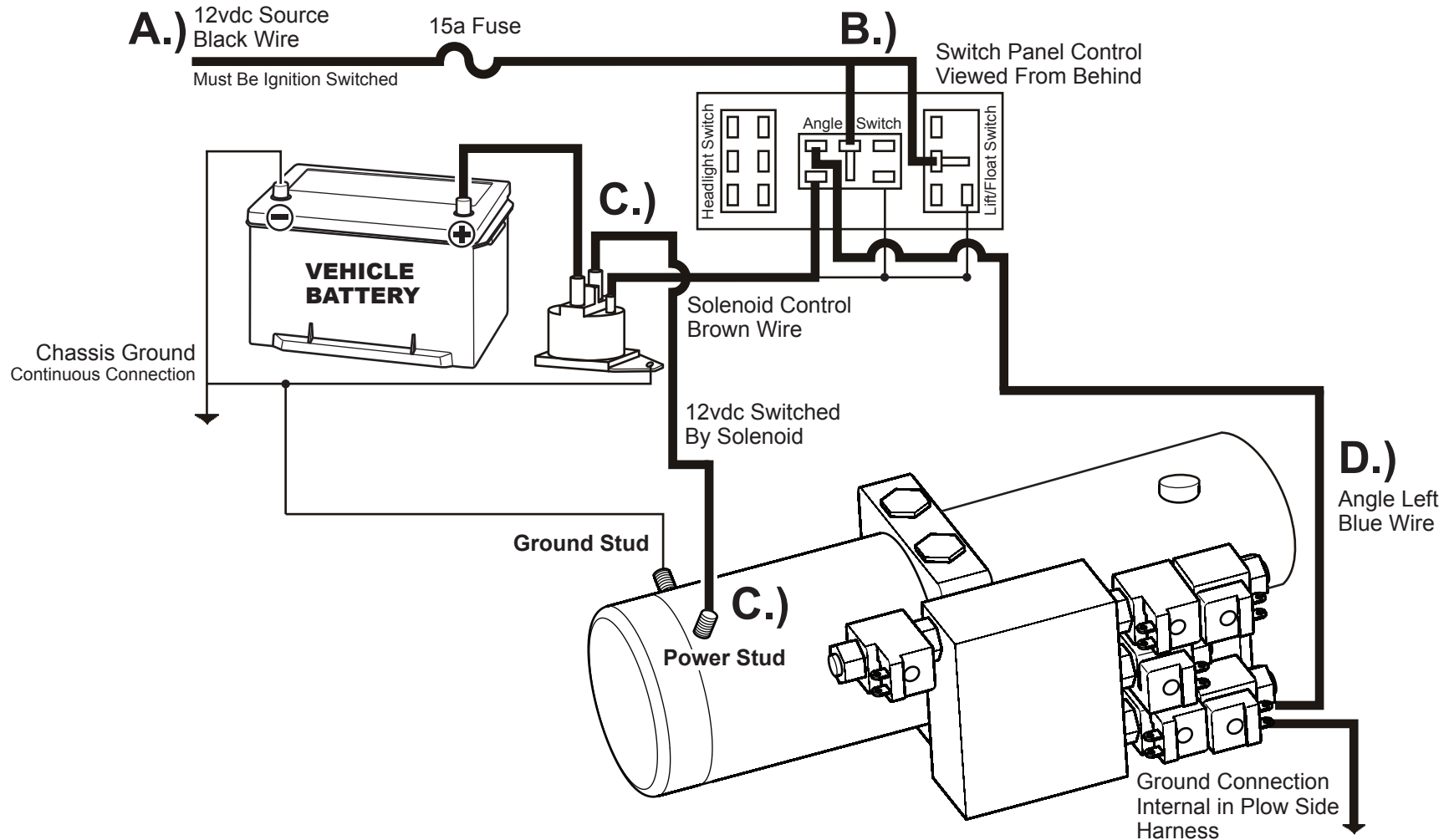

SNO-PRO / HOME-PRO / TRIP-EDGE w/HYD. JACK: ANGLE RIGHT FUNCTION - ELECTRICAL

What Happens:

- A.) Ignition 'On' energizes the Controller Power source sending 12vdc into the Controller. If equipped with a Joystick or Touch Pad, the Controller Power Switch must be in the 'On' position.
- B.) Moving the Controller to 'Angle Right' position energizes the White 'Angle Right' Wire and the Brown 'Solenoid' Wire.
- C.) The Brown 'Solenoid' Wire closes the Solenoid Contacts and sends 12vdc power to the Pump Motor.
- D.) The White 'Angle Right' Wire sends 12vdc power to the Angle Right Valve Coil.
- E.) See next page for Hydraulic Flow Chart.

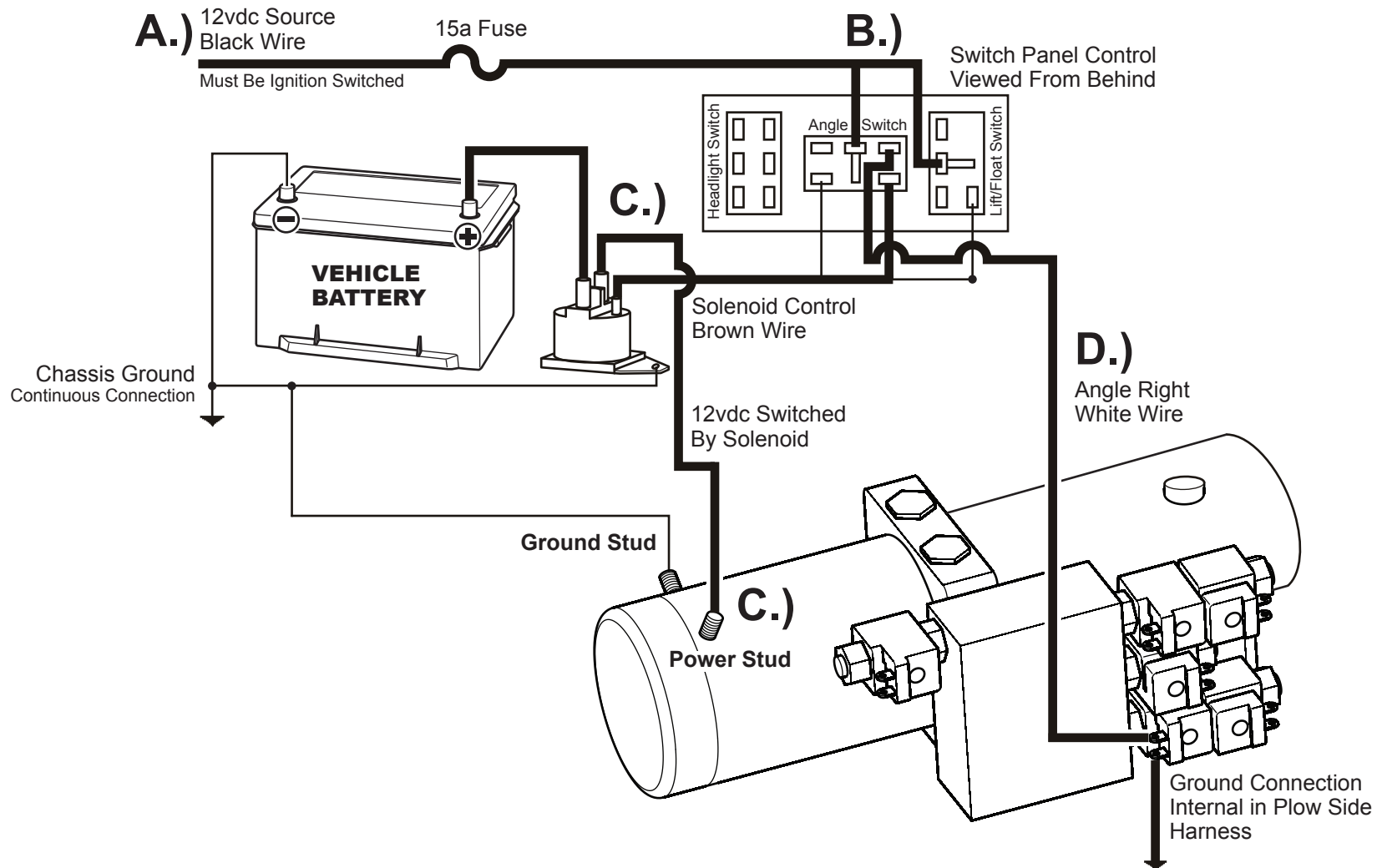

SNO-PRO / HOME-PRO / TRIP-EDGE w/HYD. JACK: AUTOMATIC JACK RETRACT FUNCTION - ELECTRICAL

What Happens:

- A.) Ignition 'On' energizes the Controller Power source sending 12vdc into the Controller. If equipped with a Joystick or Touch Pad, the Controller Power Switch must be in the 'On' position.
- B.) Moving the Controller to 'Plow Lift' position energizes the Red 'Plow Lift' Wire, the Brown 'Solenoid' Wire, and the Pink/Black 'Jack Retract' Wire.
- C.) The Brown 'Solenoid' Wire closes the Solenoid Contacts and sends 12vdc power to the Pump Motor.
- D.) The Red 'Plow Lift' Wire sends 12vdc power to the Plow Lift Valve Coil.
- E.) The Pink/Black 'Jack Retract' Wire sends 12vdc power to the Jack Retract Valve Coil.
- F.) Note: A Diode is installed between the connection of the Red 'Plow Lift' Wire and the Pink/Black 'Jack Retract' Wire. This prevents the Plow Lift Circuit from being activated when the A-Frame Jack Switch is used for the Jack Retract function.
- G.) See Next Page for Hydraulic Flow Chart.

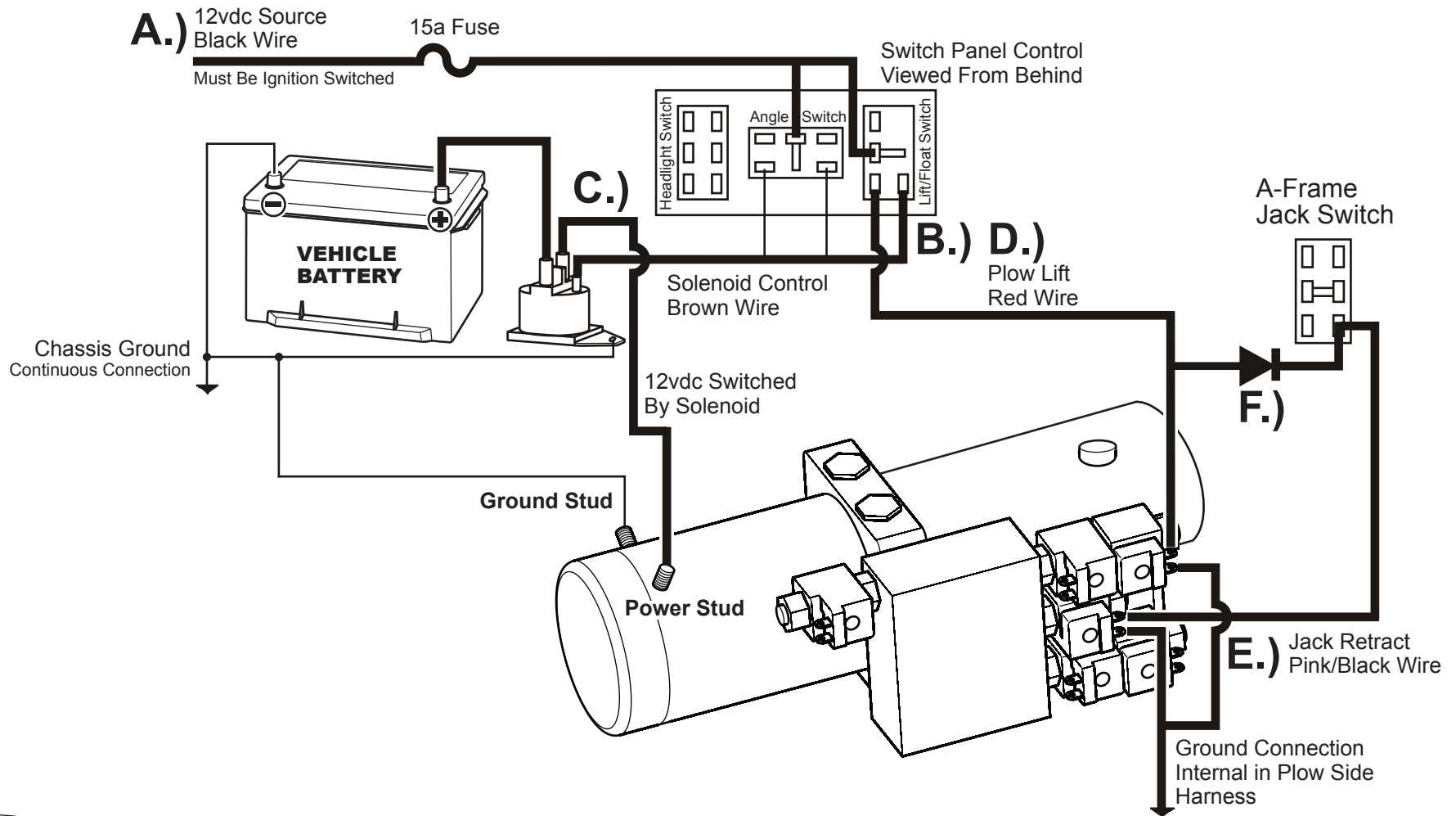

SNO-PRO / HOME-PRO / TRIP-EDGE w/HYD. JACK: JACK RETRACT USING LIFT FUNCTION - HYDRAULIC

What Happens:

- A.) Lift Function is Activated with Controller.
- B.) Brown Wire activates Motor Solenoid.
- C.) 12vdc Motor spins Pump developing pressure.
- D.) Red Wire shifts 'Plow Lift/Jack Extend' Valve to Lift function.
- E.) Pink/Black Wire shifts Jack Retract Valve.
- F.) Pump pressure is supplied to 'H' Port extending Lift Cylinder.
- G.) Jack Cylinder drains fluid through 'X' Port to Reservoir retracting Jack Leg.

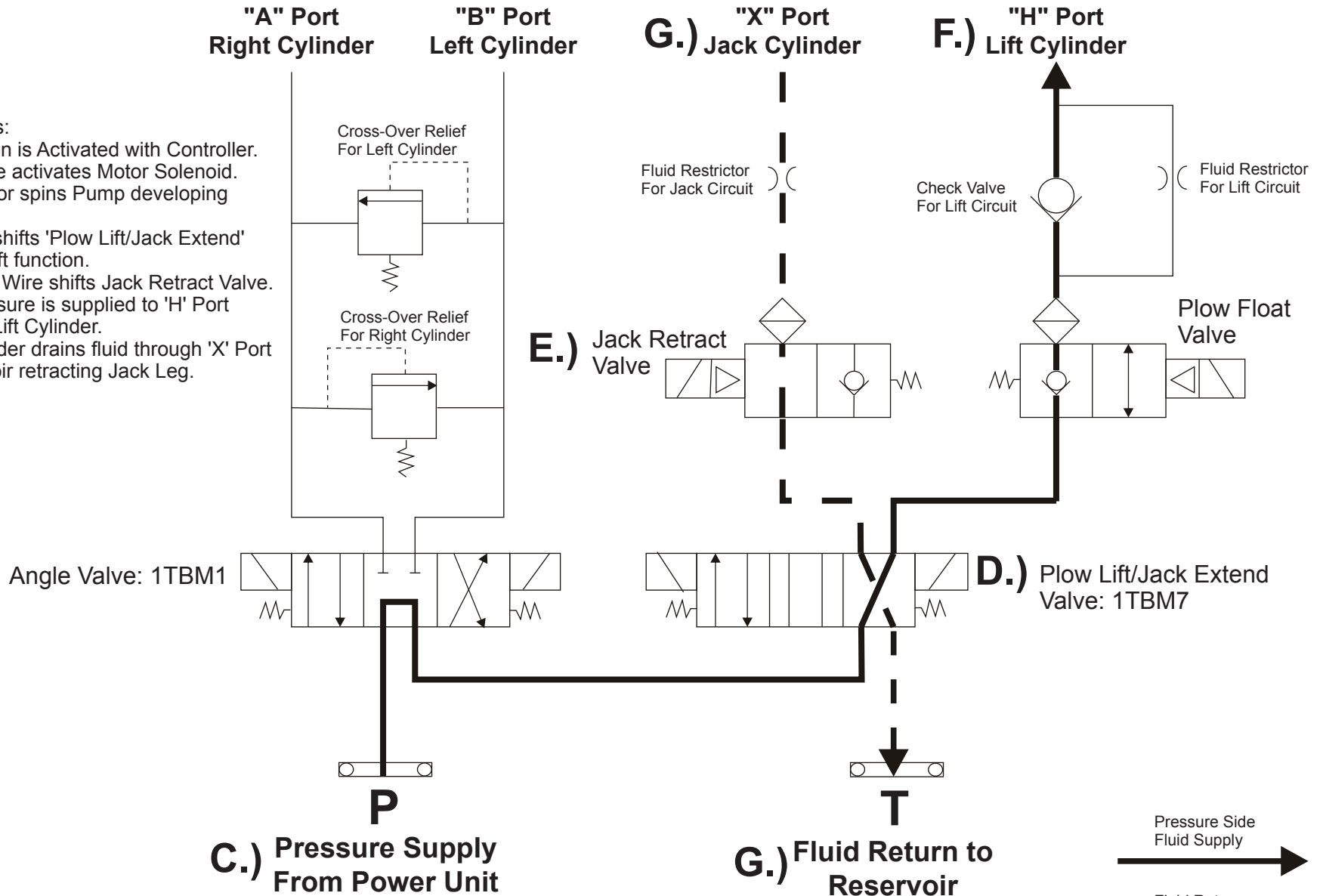

SNO-PRO / HOME-PRO / TRIP-EDGE w/HYD. JACK: PLOW FLOAT FUNCTION - ELECTRICAL

What Happens:

- A.) Ignition 'On' energizes the Controller Power source sending 12vdc into the Controller. If equipped with a Joystick or Touch Pad, the Controller Power Switch must be in the 'On' position.
- B.) Moving the Controller to 'Plow Float' position energizes the Green 'Float' Wire.
- C.) The Green 'Float' Wire sends 12vdc power to the Float Valve Coil.
- D.) The A-Frame Jack Switch is energized any time 'Float' is activated.
- E.) See Next Page for Hydraulic Flow Chart.

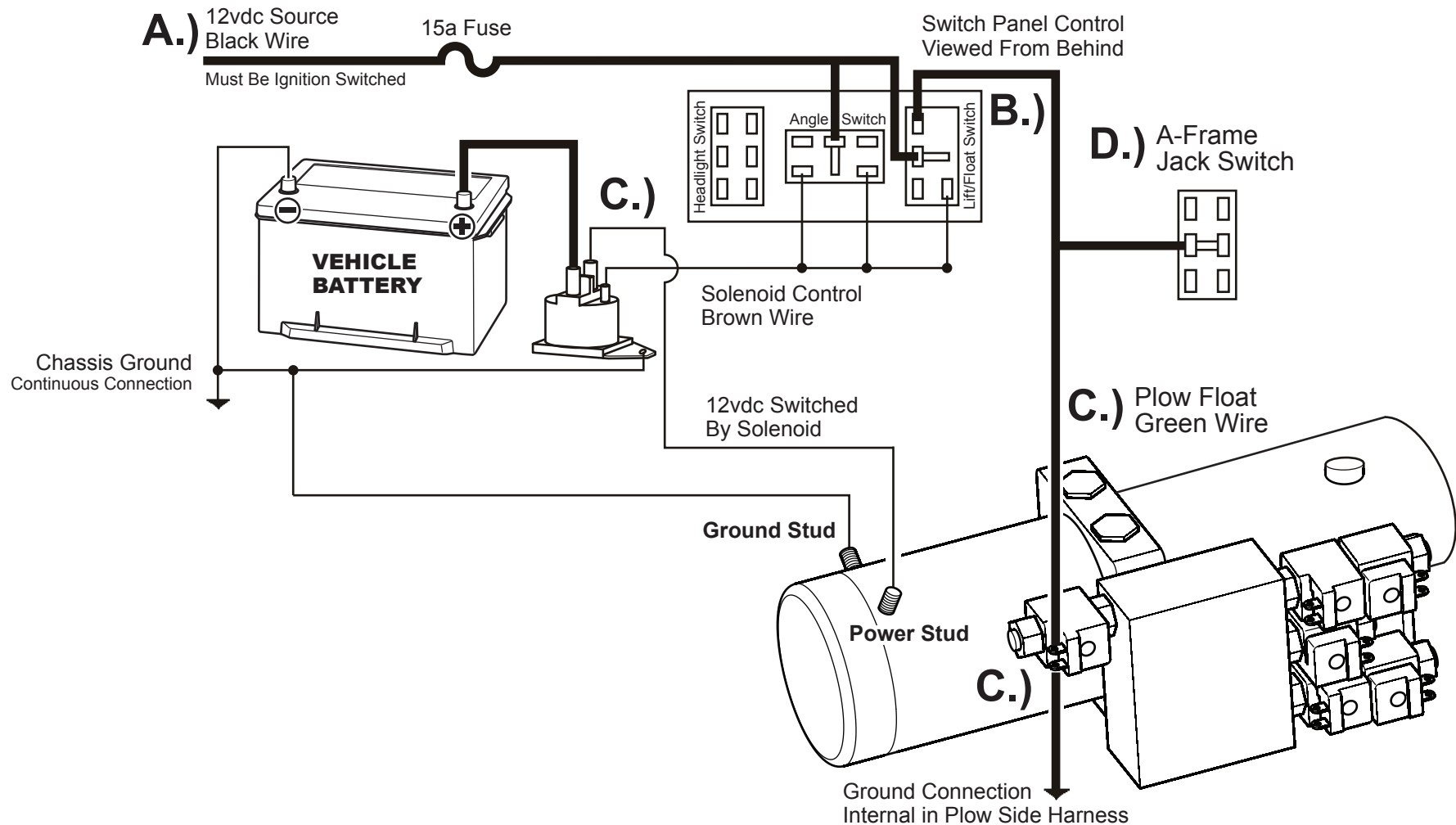

SNO-PRO / HOME-PRO / TRIP-EDGE w/HYD. JACK: PLOW FLOAT FUNCTION - HYDRAULIC

What Happens:

- A.) Lift Function is activated with Controller.
- B.) Green Wire shifts 'Float' Valve to Open position.
- C.) Fluid from Lift Cylinder returns to Reservoir through Flow Restrictor slowing retraction.

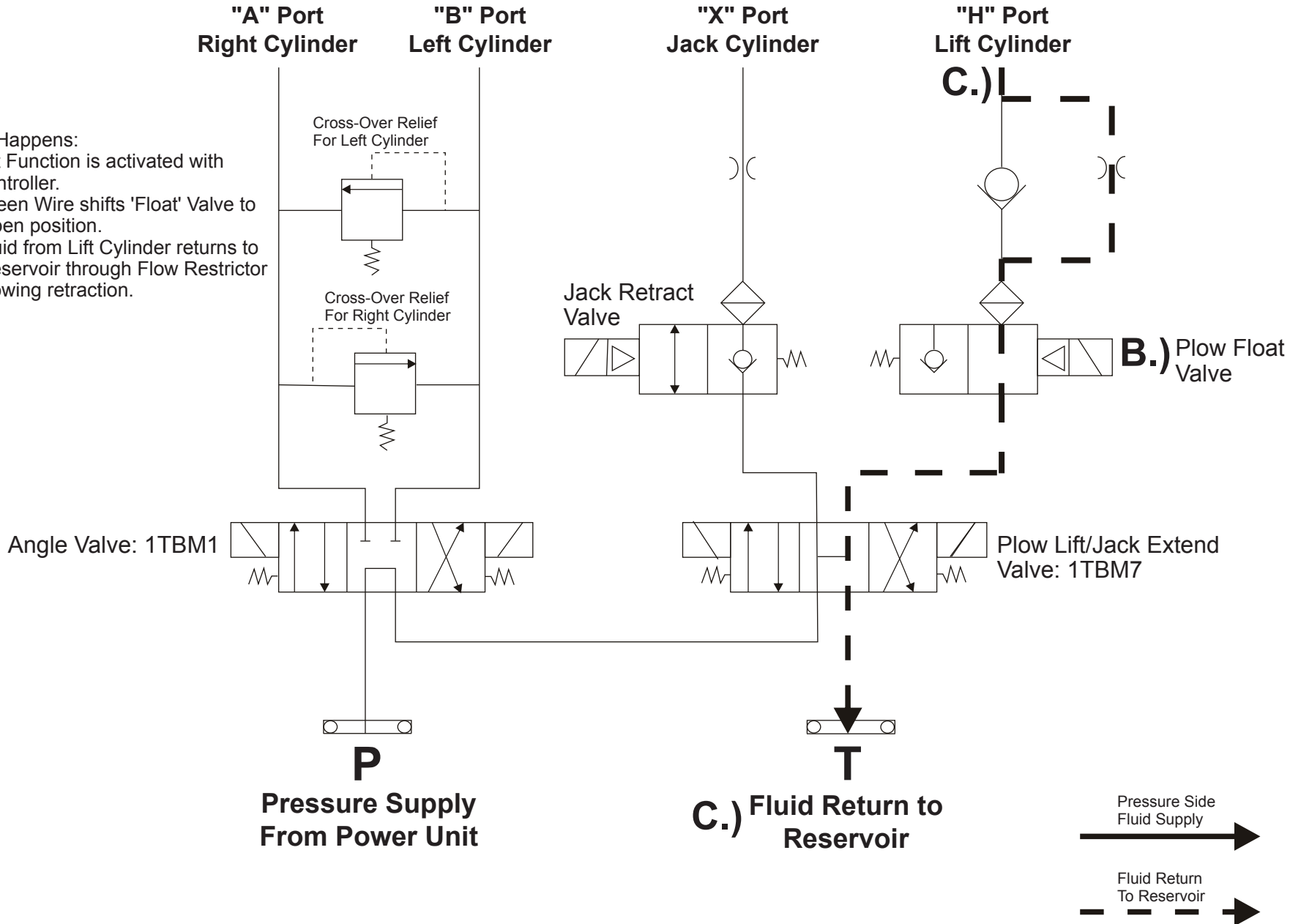

SNO-PRO / HOME-PRO / TRIP-EDGE w/HYD. JACK: JACK EXTEND FUNCTION - ELECTRICAL

What Happens:

- A.) Ignition 'On' energizes the Controller Power source sending 12vdc into the Controller. If equipped with a Joystick or Touch Pad, the Controller Power Switch must be in the 'On' position.
- B.) Moving the Controller to 'Plow Float' position energizes the Green 'Plow Float' Wire which, in turn, sends power to the A-Frame Jack Switch.
- C.) Moving the A-Frame Jack Switch to the 'Jack Extend' position energizes the Blue/Black 'Jack Extend' Wire and the Brown 'Solenoid' Wire.
- D.) The Brown 'Solenoid' Wire closes the Solenoid Contacts and sends 12vdc power to the Pump Motor.
- E.) The Blue/Black 'Jack Extend' Wire sends 12vdc power to the Jack Extend Valve Coil.
- E.) See Next Page for Hydraulic Flow Chart.

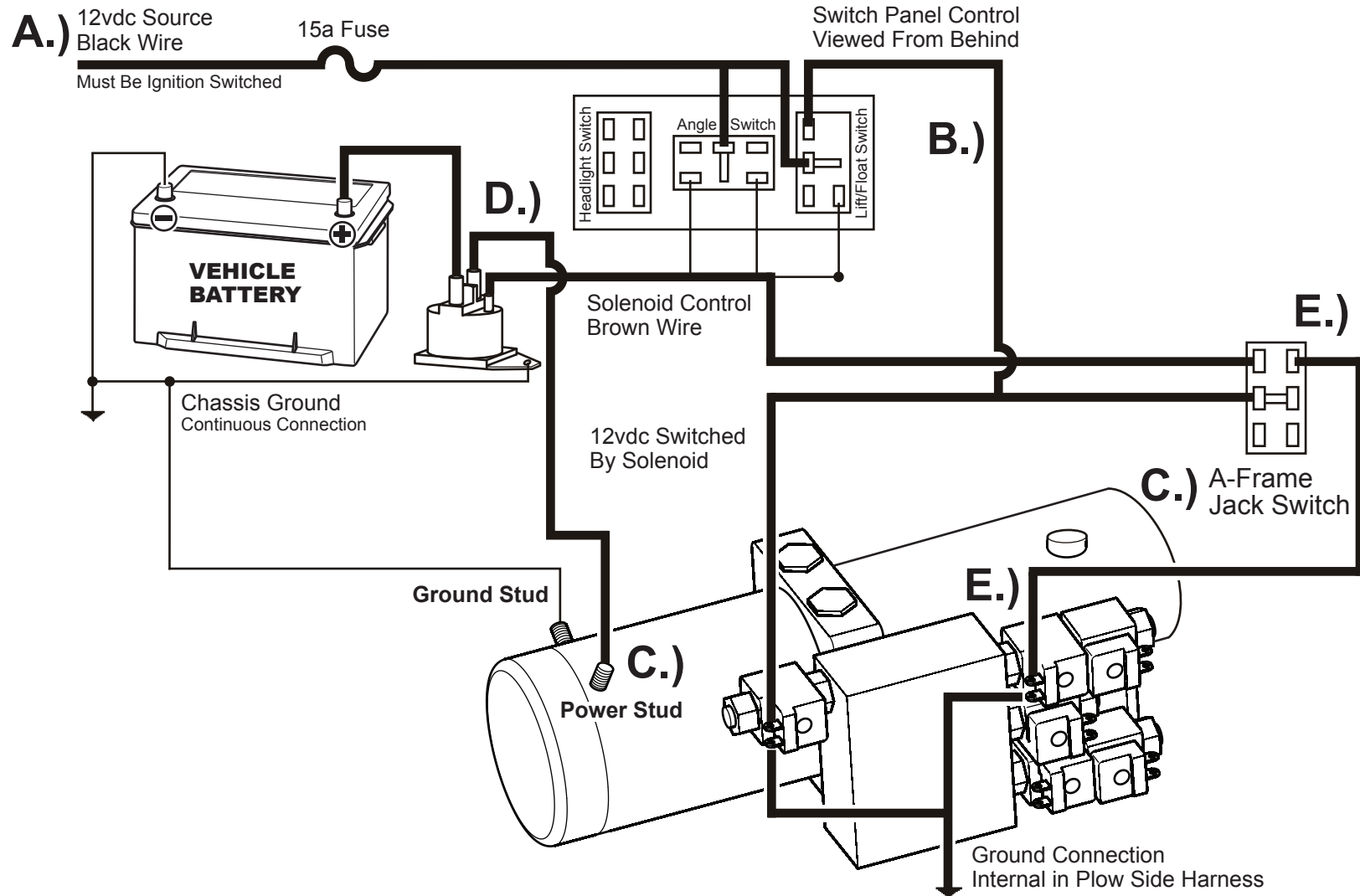

SNO-PRO / HOME-PRO / TRIP-EDGE w/HYD. JACK: JACK EXTEND FUNCTION - HYDRAULIC

What Happens:

- A.) Lift Function is activated with Controller.
- B.) Green Wire shifts 'Float' Valve to Open position and powers A-Frame Jack Switch.
- C.) Fluid from Lift Cylinder returns to Reservoir.
- D.) Jack Extend function is activated using A-Frame Jack Switch.
- E.) Blue/Black Wire shifts 'Plow Lift/Jack Extend' Valve to Jack Extend position.
- F.) Brown Wire activates Motor Solenoid sending power to 12vdc Motor.
- G.) 12vdc Motor spins Pump developing pressure.
- H.) Pump pressure is supplied to 'X' Port extending Jack Leg from bottom of A-Frame.

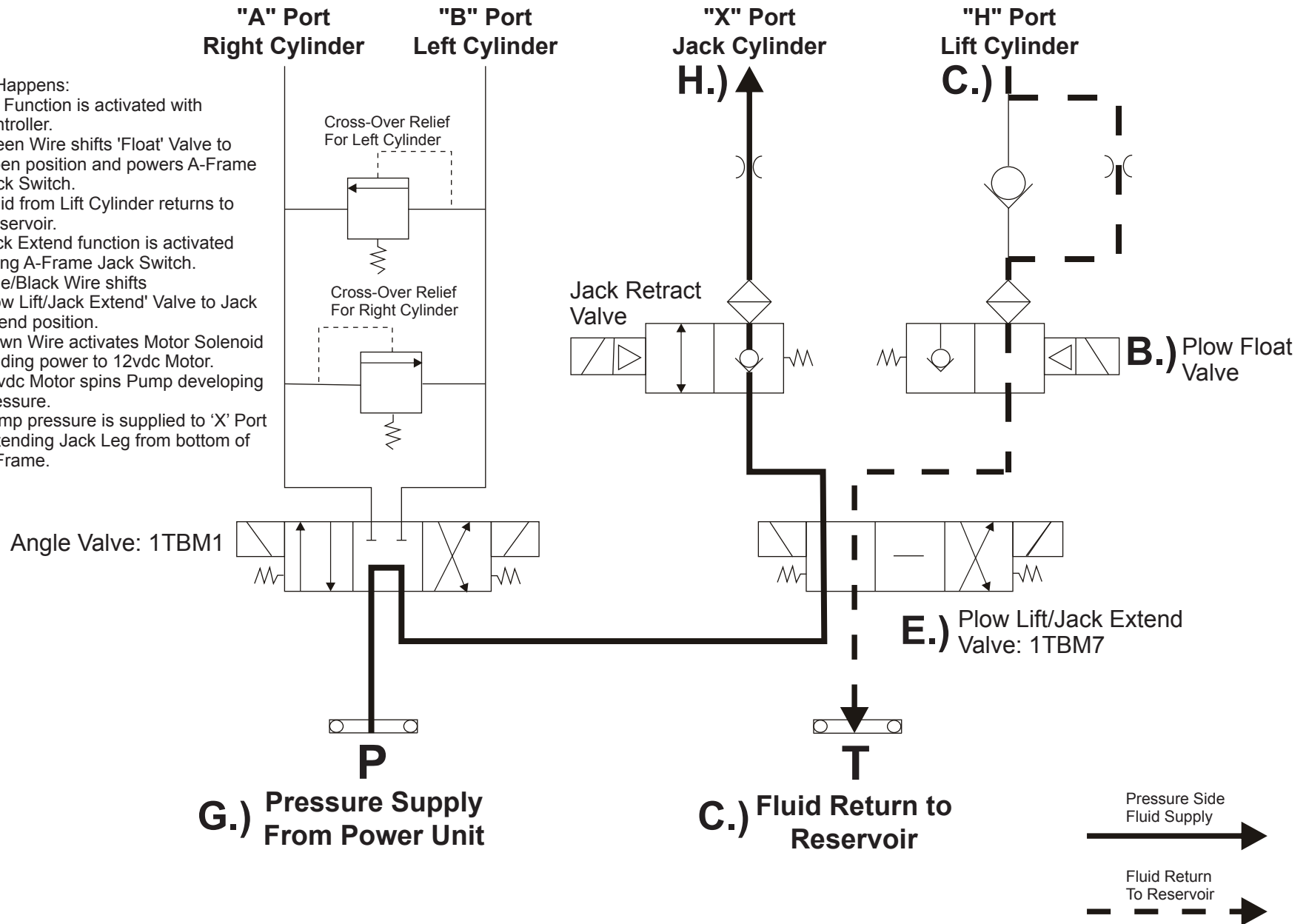

SNO-PRO / HOME-PRO / TRIP-EDGE w/HYD. JACK: JACK RETRACT FUNCTION - ELECTRICAL USING A-FRAME JACK SWITCH

What Happens:

- A.) Ignition 'On' energizes the Controller Power source sending 12vdc into the Controller. If equipped with a Joystick or Touch Pad, the Controller Power Switch must be in the 'On' position.
- B.) Moving the Controller to 'Plow Float' position energizes the Green 'Plow Float' Wire which, in turn, sends power to the A-Frame Jack Switch.
- C.) Moving the A-Frame Jack Switch to the 'Jack Retract' position energizes the Pink/Black 'Jack Retract' Wire.
- D.) The Pink/Black 'Jack Retract' Wire sends 12vdc power to the Jack Retract Valve Coil.
- E.) See Next Page for Hydraulic Flow Chart.

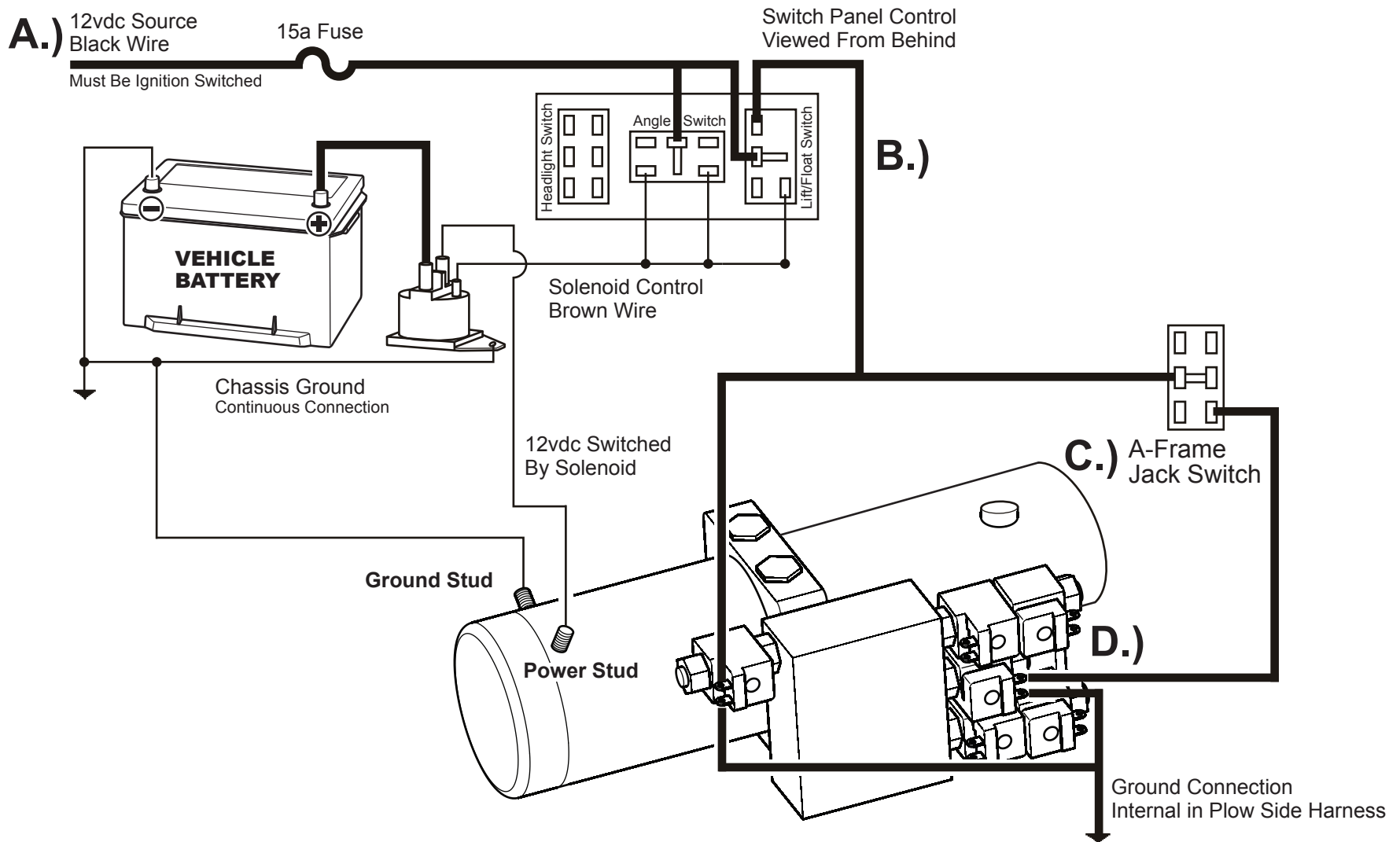

SNO-PRO / HOME-PRO / TRIP-EDGE w/HYD. JACK: JACK RETRACT FUNCTION - HYDRAULIC USING A-FRAME JACK SWITCH

What Happens:

- A.) Lift Function is activated with Controller.
- B.) Green Wire shifts 'Float' Valve to Open position and powers A-Frame Jack Switch.
- C.) Fluid from Lift Cylinder returns to Reservoir through the 'H' Port.
- D.) Jack Retract function is activated using A-Frame Jack Switch.
- E.) Pink/Black Wire shifts 'Jack Retract' Valve to Jack Extend position.
- F.) Fluid from Jack Cylinder returns to Reservoir through 'X' Port retracting Jack Leg.

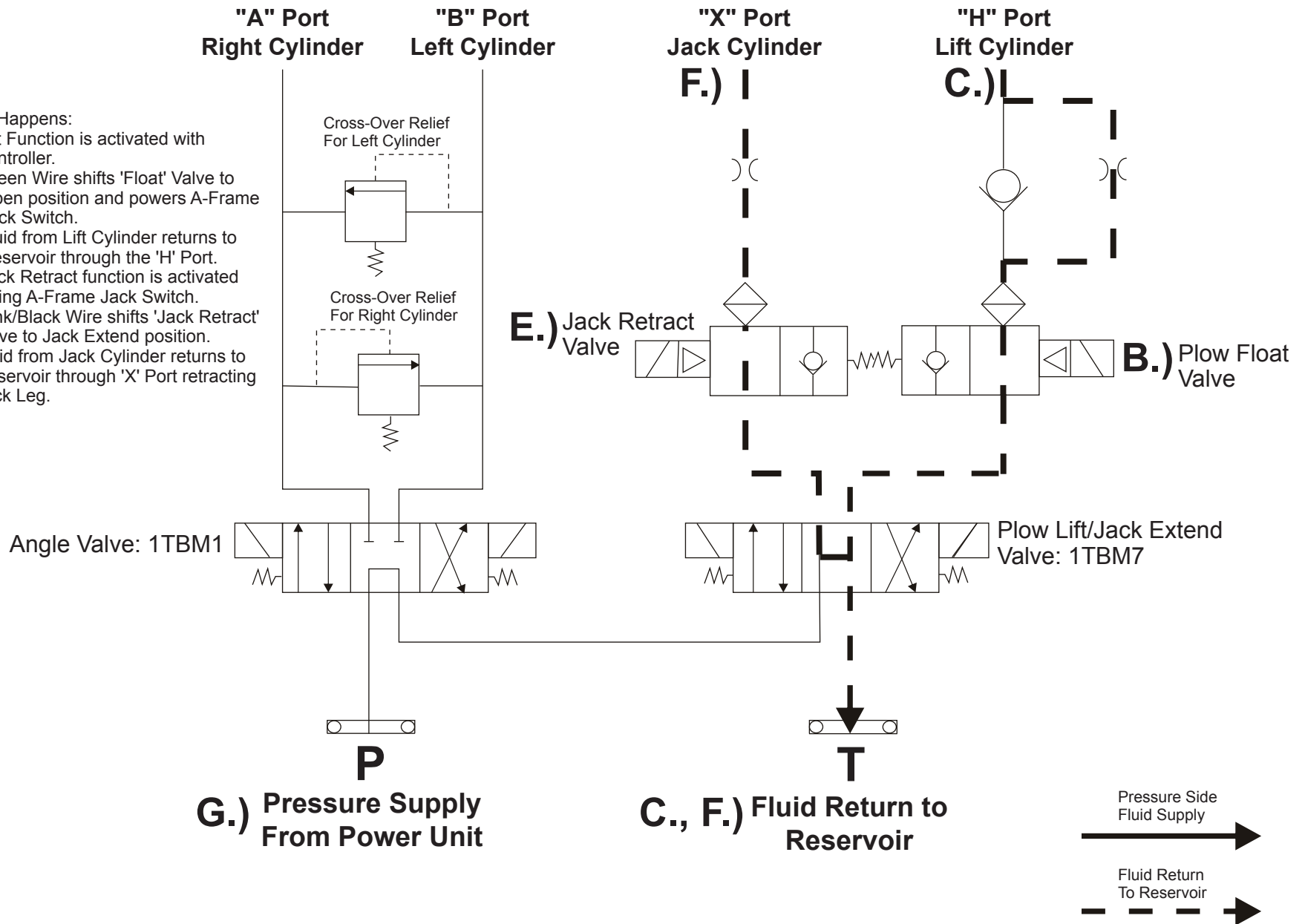

SNO-PRO / HOME-PRO / TRIP-EDGE w/HYD. JACK: ELECTRICAL/HYDRAULIC POWER UNIT W/MANIFOLD

MANIFOLD END VIEW

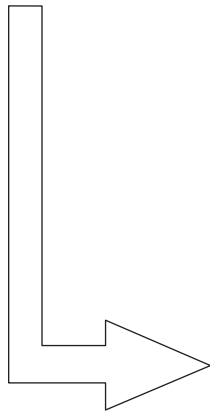
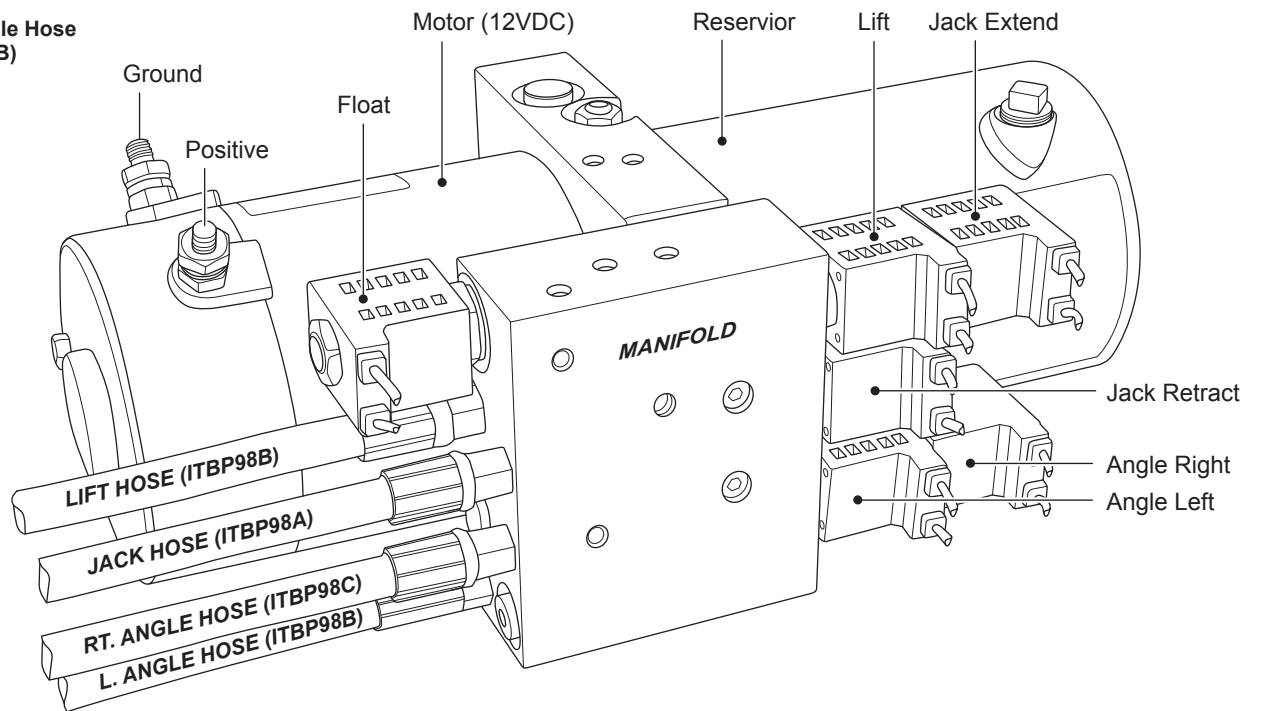
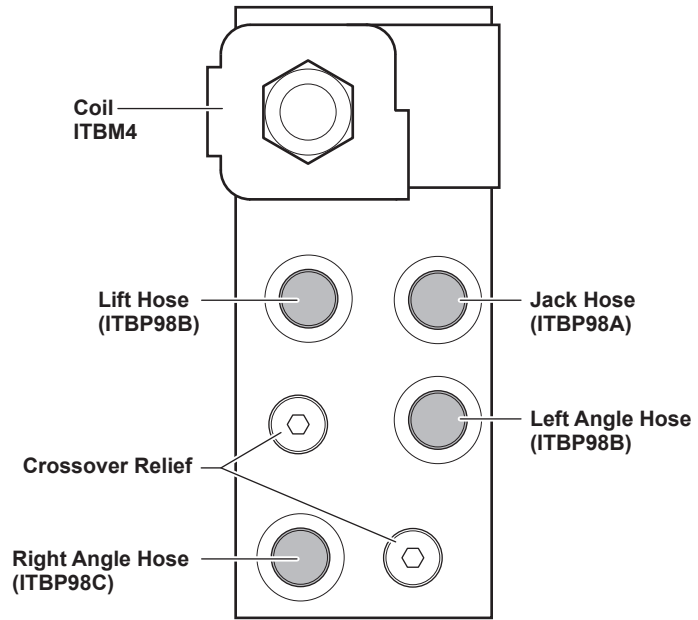

SNO-PRO / HOME-PRO / TRIP-EDGE w/GAS SPRING JACK: ANGLE LEFT FUNCTION - ELECTRICAL

What Happens:

- A.) Ignition 'On' energizes the Controller Power source sending 12vdc into the Controller. If equipped with a Joystick or Touch Pad, the Controller Power Switch must be in the 'On' position.
- B.) Moving the Controller to 'Angle Left' position energizes the Blue 'Angle Left' Wire and the Brown 'Solenoid' Wire.
- C.) The Brown 'Solenoid' Wire closes the Solenoid Contacts and sends 12vdc power to the Pump Motor.
- D.) The Blue 'Angle Left' Wire sends 12vdc power to the Angle Left Valve Coil.
- E.) See Next Page for Hydraulic Flow Chart.

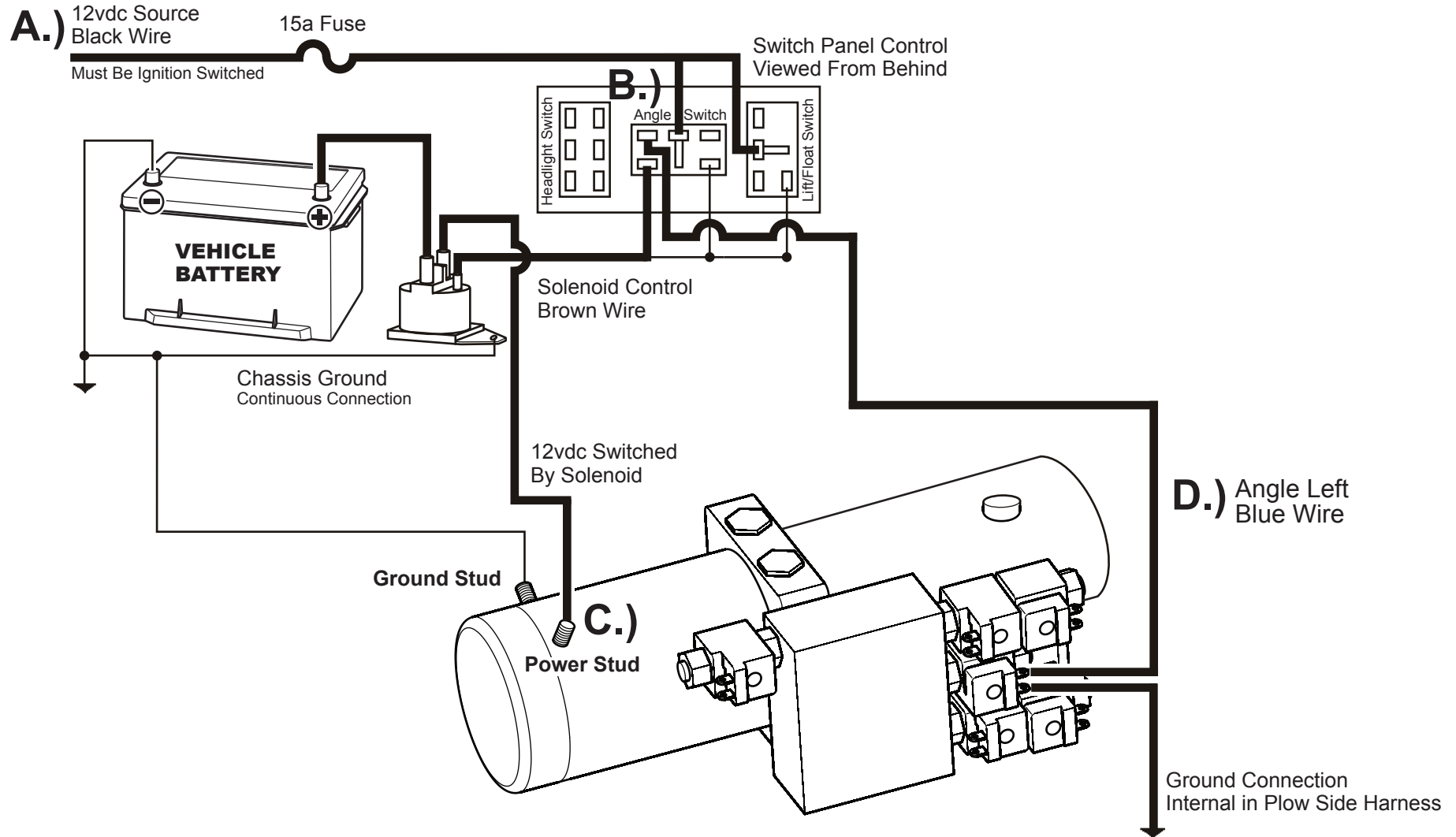

SNO-PRO / HOME-PRO / TRIP-EDGE w/GAS SPRING JACK: ANGLE LEFT FUNCTION - HYDRAULIC

What Happens:

- A.) Left Angle Function is activated with Controller.
- B.) Brown Wire activates Motor Solenoid.
- C.) 12vdc Motor spins Pump developing pressure.
- D.) Blue Wire shifts 'Angle Valve' to Angle Left position.
- E.) Pump pressure is supplied to 'A' Port extending Right Angle Cylinder.
- F.) As Plow angles to the left, fluid from the Left Angle Cylinder returns to the Reservoir.

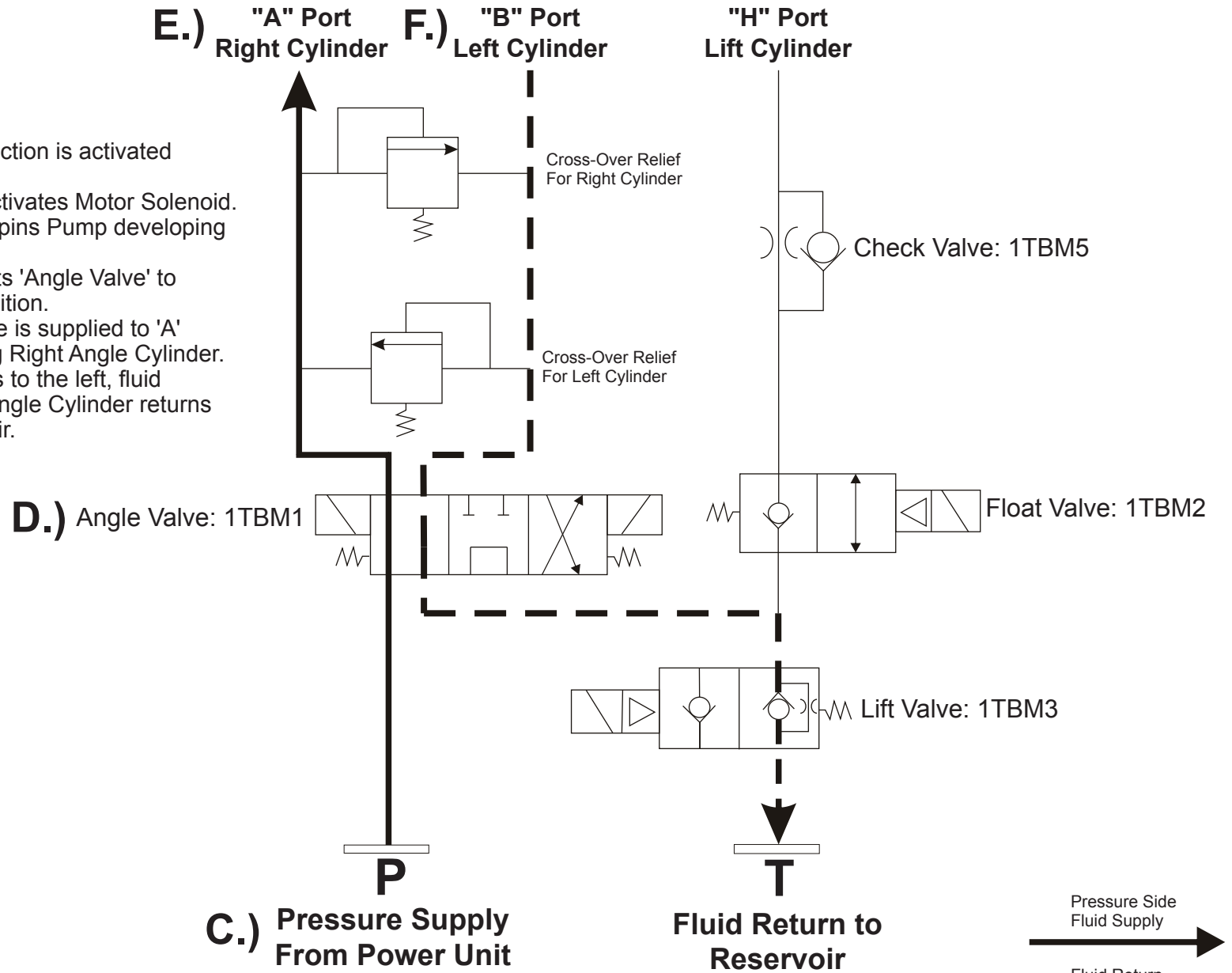

SNO-PRO / HOME-PRO / TRIP-EDGE w/GAS SPRING JACK: ANGLE RIGHT FUNCTION - ELECTRICAL

What Happens:

- A.) Ignition 'On' energizes the Controller Power source sending 12vdc into the Controller. If equipped with a Joystick or Touch Pad, the Controller Power Switch must be in the 'On' position.
- B.) Moving the Controller to 'Angle Right' position energizes the White 'Angle Right' Wire and the Brown 'Solenoid' Wire.
- C.) The Brown 'Solenoid' Wire closes the Solenoid Contacts and sends 12vdc power to the Pump Motor.
- D.) The White 'Angle Right' Wire sends 12vdc power to the Angle Right Valve Coil.
- E.) See Next Page for Hydraulic Flow Chart.

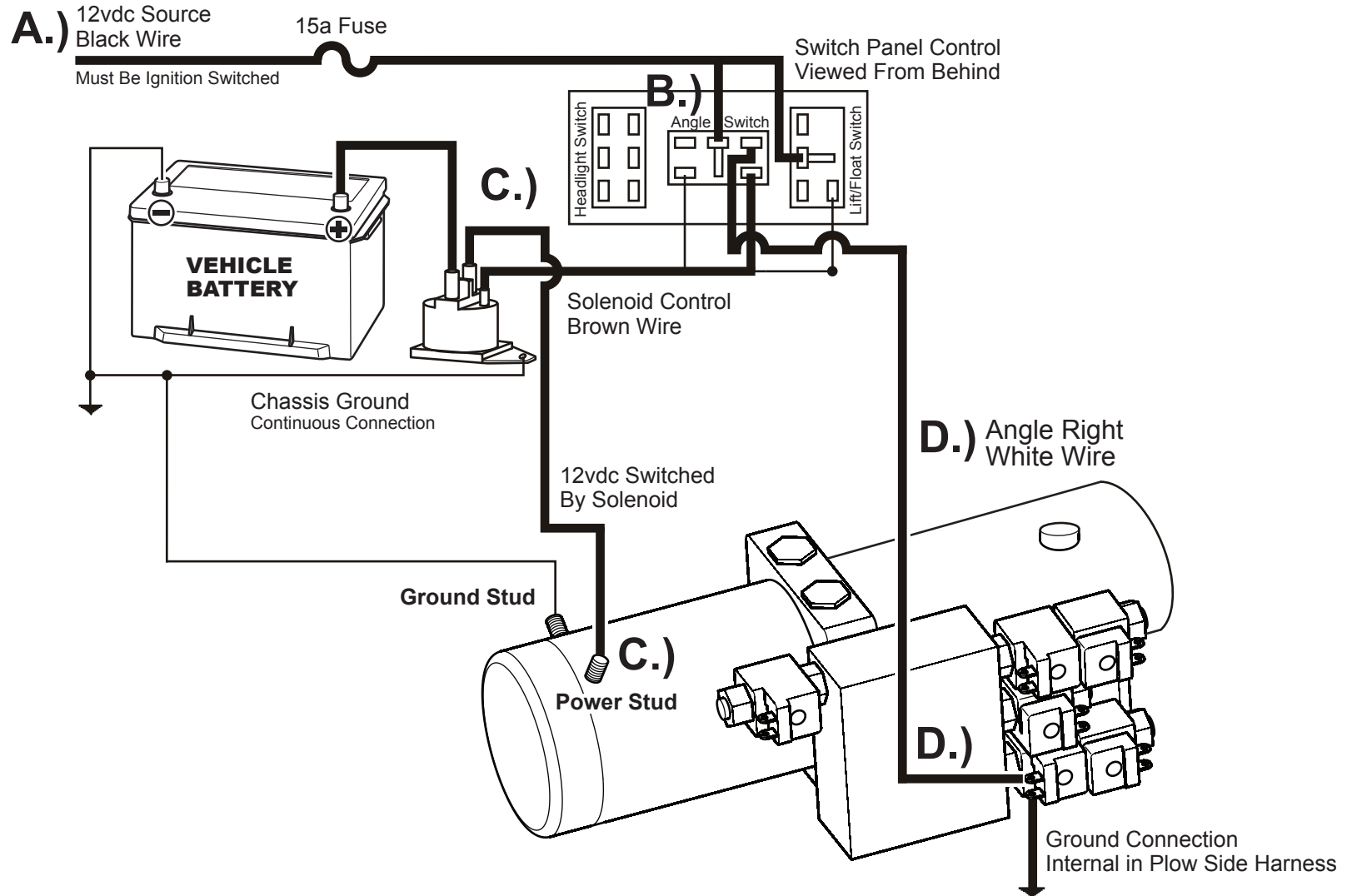

SNO-PRO / HOME-PRO / TRIP-EDGE w/GAS SPRING JACK: ANGLE RIGHT FUNCTION - HYDRAULIC

What Happens:

- A.) Right Angle Function is activated with Controller.
- B.) Brown Wire activates Motor Solenoid.
- C.) 12vdc Motor spins Pump developing pressure.
- D.) White Wire shifts 'Angle Valve' to Angle Right position.
- E.) Pump pressure is supplied to 'B' Port extending Left Angle Cylinder.
- F.) As Plow angles to the right, fluid from the Right Angle Cylinder returns to the Reservoir.

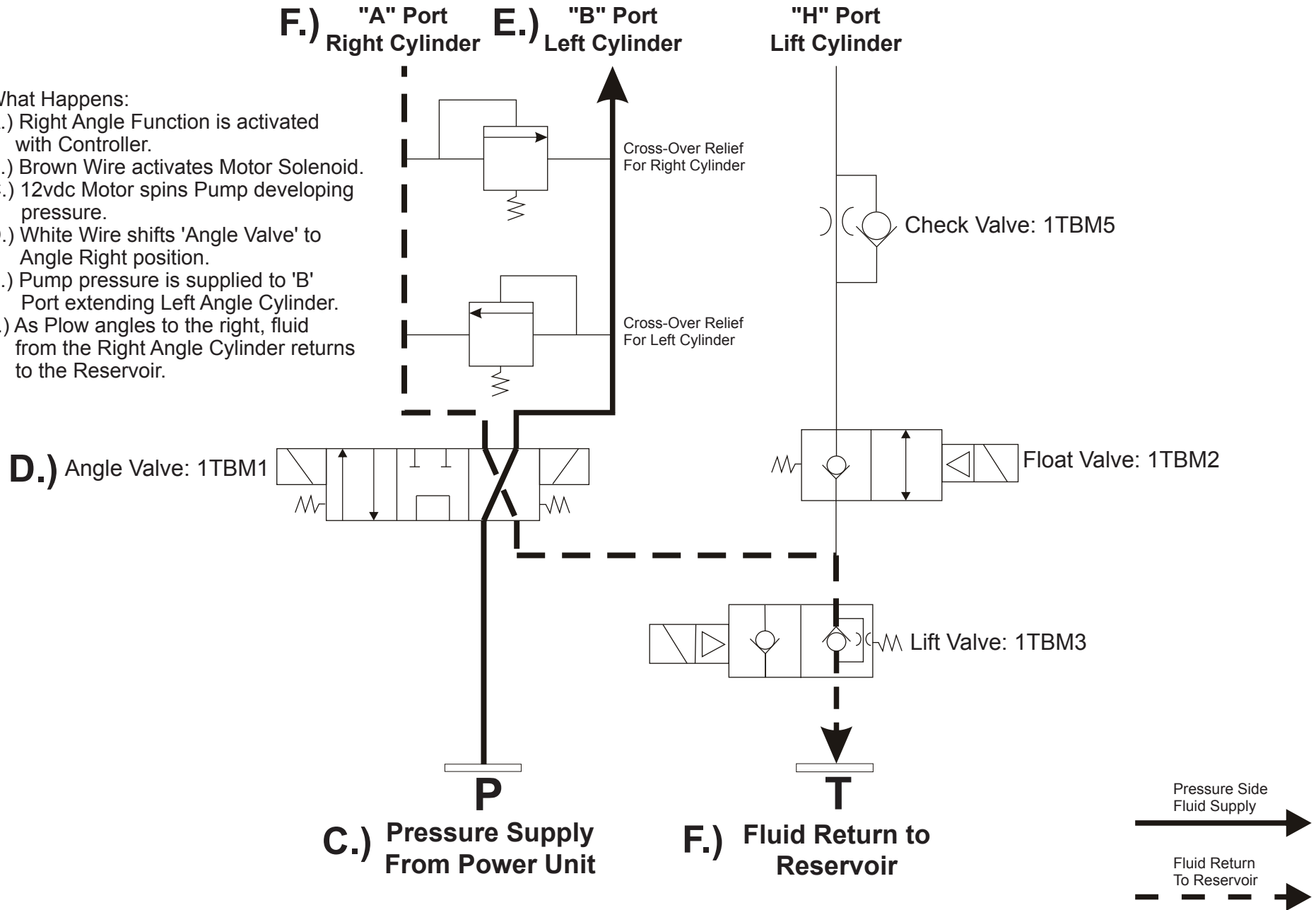

SNO-PRO / HOME-PRO / TRIP-EDGE w/GAS SPRING JACK: PLOW LIFT FUNCTION - ELECTRICAL

What Happens:

- A.) Ignition 'On' energizes the Controller Power source sending 12vdc into the Controller. If equipped with a Joystick or Touch Pad, the Controller Power Switch must be in the 'On' position.
- B.) Moving the Controller to 'Plow Lift' position energizes the Red 'Lift' Wire and the Brown 'Solenoid' Wire.
- C.) The Brown 'Solenoid' Wire closes the Solenoid Contacts and sends 12vdc power to the Pump Motor.
- D.) The Red 'Lift' Wire sends 12vdc power to the Lift Valve Coil.
- E.) See Next Page for Hydraulic Flow Chart.

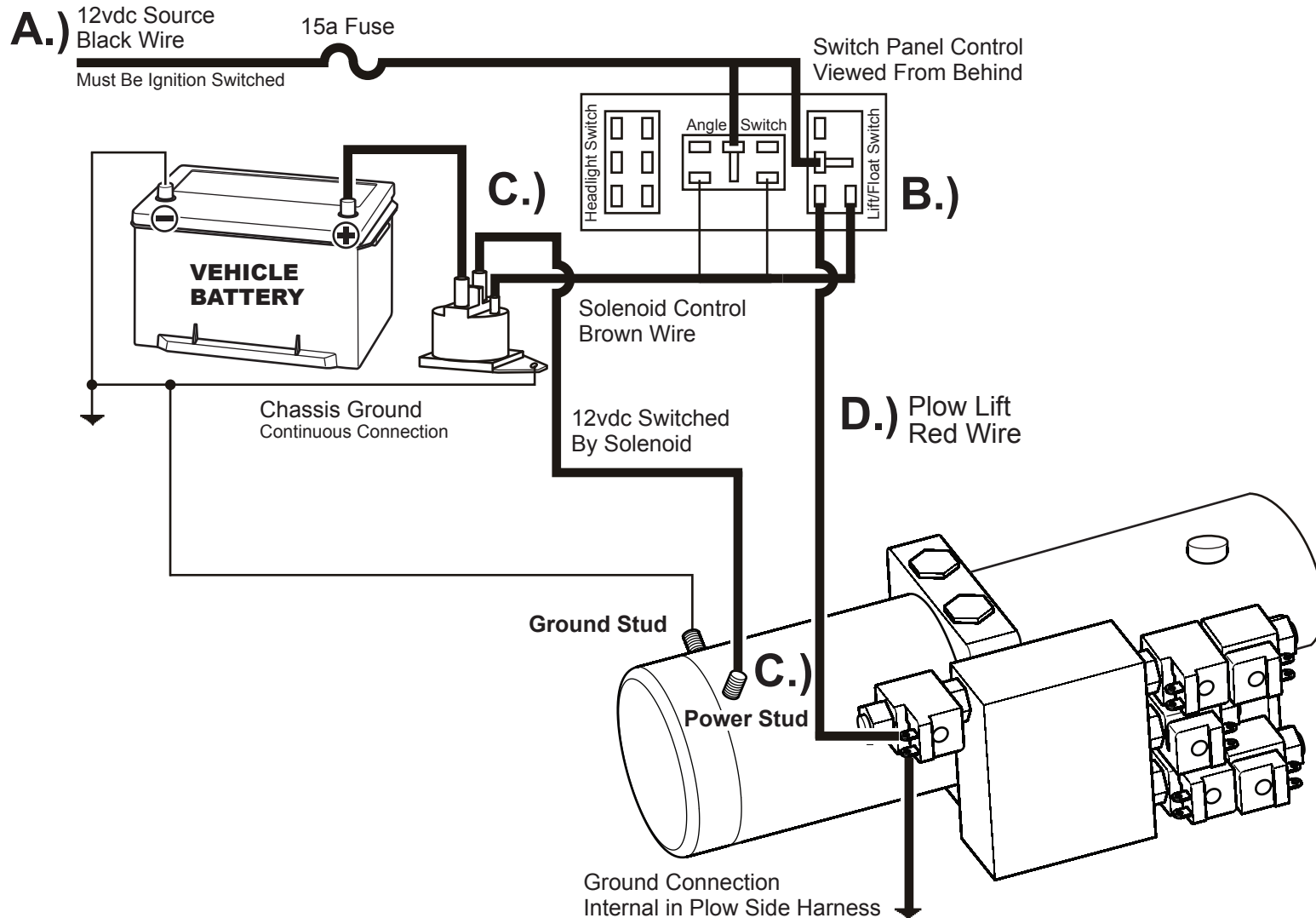

SNO-PRO / HOME-PRO / TRIP-EDGE w/GAS SPRING JACK: PLOW LIFT FUNCTION - HYDRAULIC

What Happens:

- A.) Lift Function is activated with Controller.
- B.) Brown Wire activates Motor Solenoid.
- C.) 12vdc Motor spins Pump developing pressure.
- D.) Red Wire shifts 'Plow Lift' Valve from static position.
- E.) Pump pressure is supplied to 'H' Port extending Lift Cylinder.

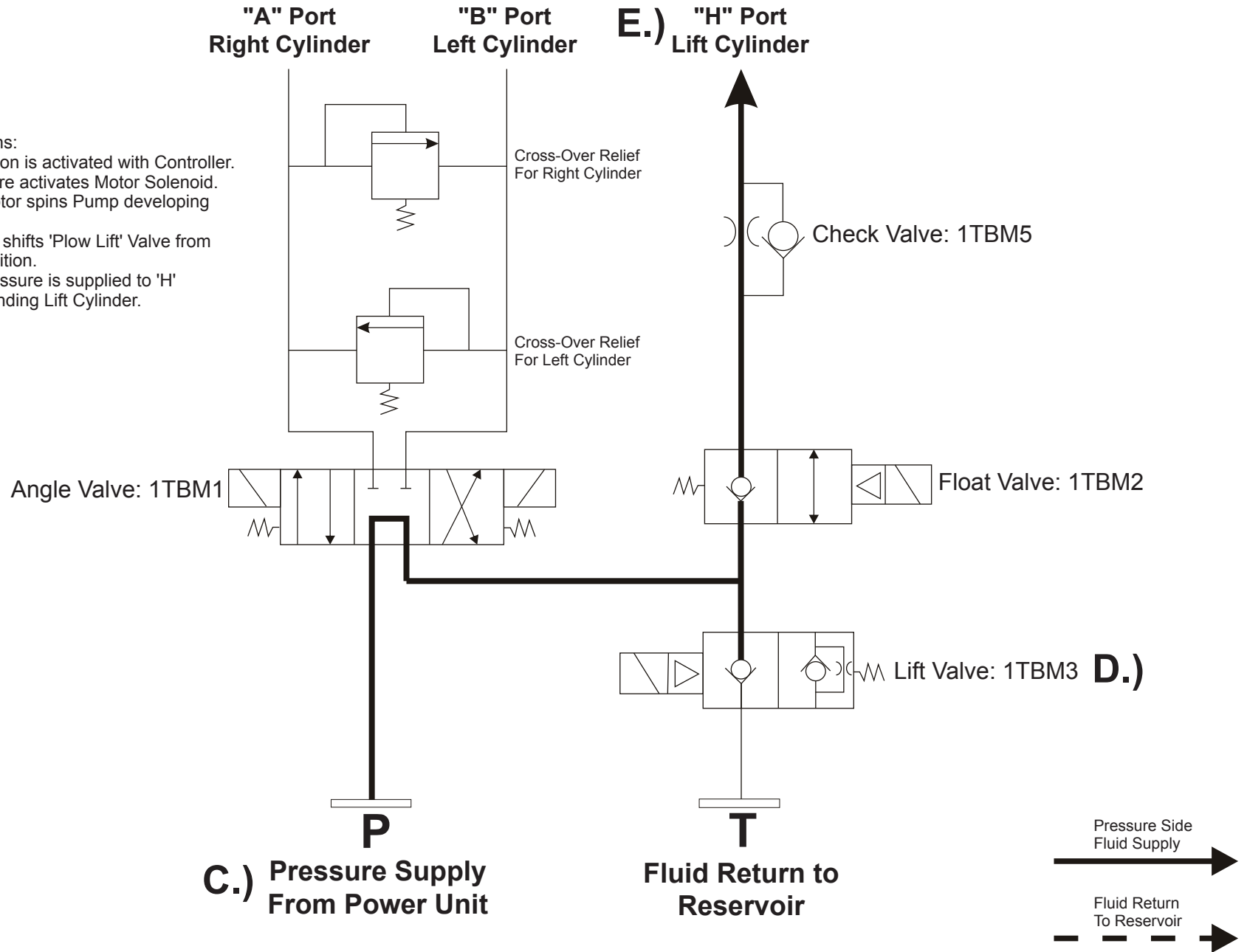

SNO-PRO / HOME-PRO / TRIP-EDGE w/GAS SPRING JACK: PLOW FLOAT FUNCTION - ELECTRICAL

What Happens:

- A.) Ignition 'On' energizes the Controller Power source sending 12vdc into the Controller. If equipped with a Joystick or Touch Pad, the Controller Power Switch must be in the 'On' position.
- B.) Moving the Controller to 'Plow Float' position energizes the Green 'Float' Wire.
- C.) The Green 'Float' Wire sends v power to the Float Valve Coil.
- D.) See Next Page for Hydraulic Flow Chart.

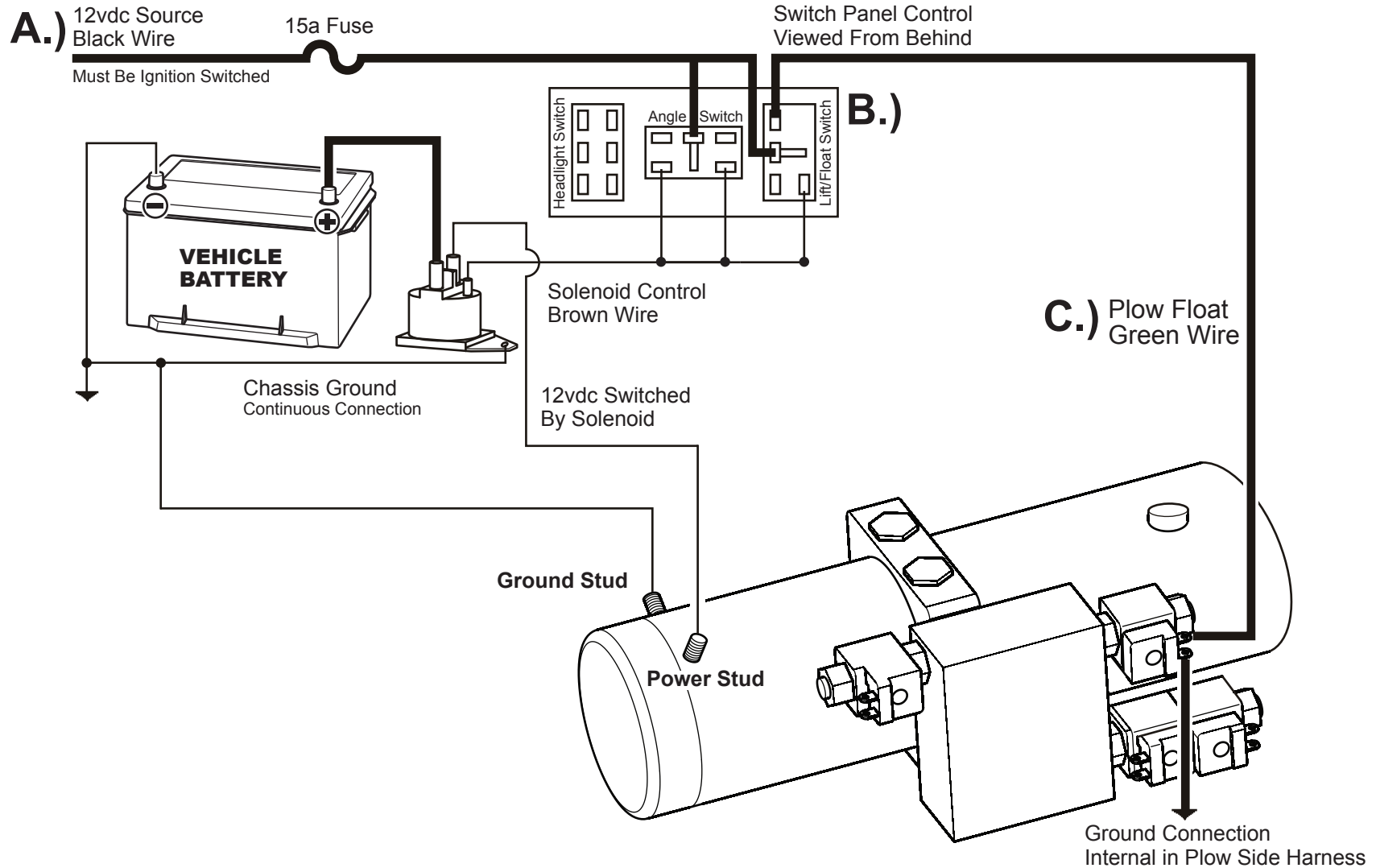

SNO-PRO / HOME-PRO / TRIP-EDGE w/GAS SPRING JACK: PLOW FLOAT FUNCTION - HYDRAULIC

What Happens:

- A.) Lift Function is activated with Controller.
- B.) Green Wire shifts 'Float' Valve to Open position.
- C.) Fluid from Lift Cylinder returns to Reservoir.

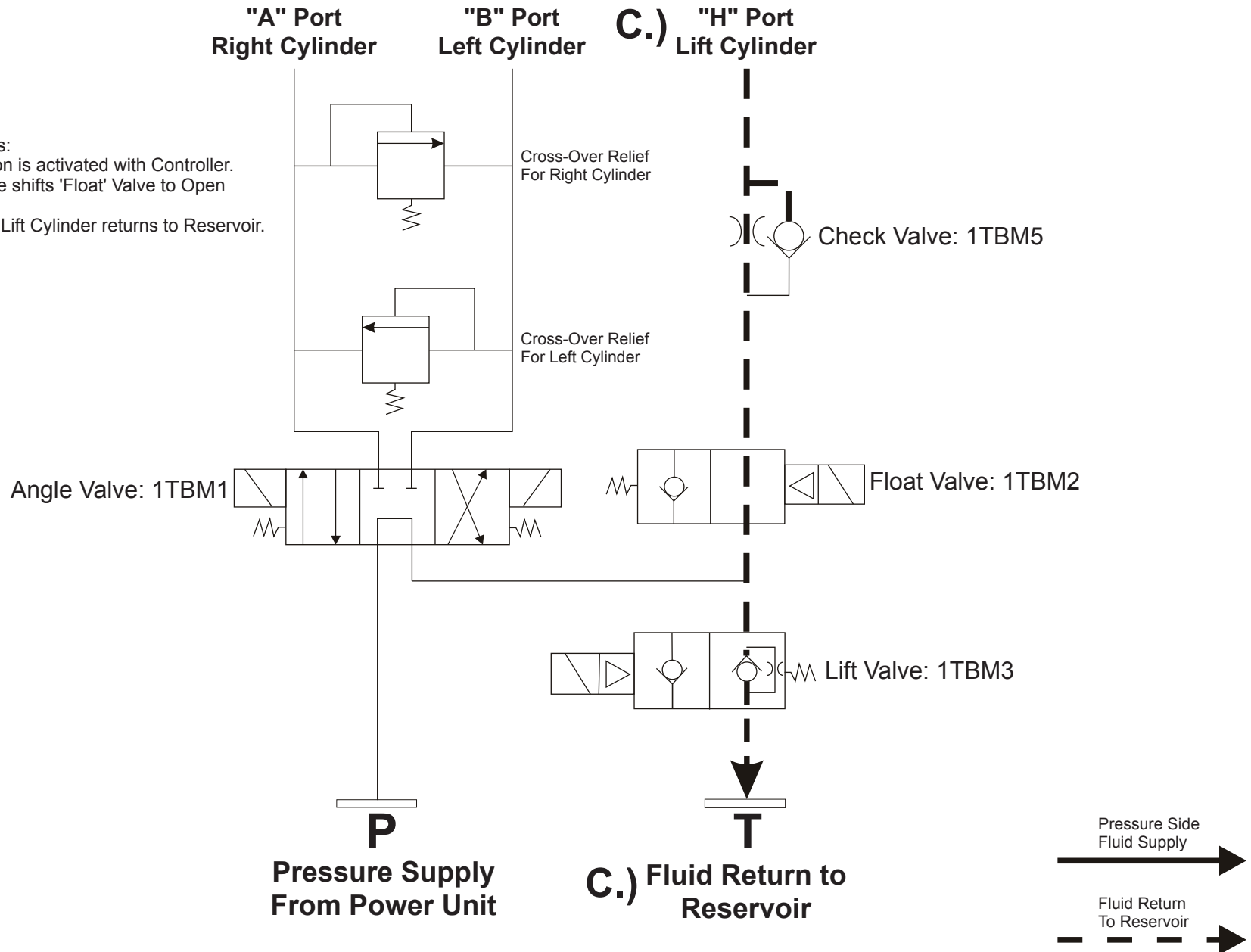

SNO-PRO V-PLOW w/SINGLE ACTING CYLINDERS & SPRING RETURN: LEFT ANGLE FUNCTION - ELECTRICAL

What Happens:

- A.) Ignition 'On' energizes the Controller Power source sending 12vdc into the Controller. Touch Pad Power Switch must be in the 'On' position.
- B.) Pushing the 'Left Angle' button energizes the White 'W2 Extend' Wire, Blue/Black 'W1 Retract' Wire and the Brown 'Solenoid' Wire.
- C.) The Brown 'Solenoid' Wire closes the Solenoid Contacts and sends 12vdc power to the Pump Motor.
- D.) The White 'W2 Extend' Wire sends 12vdc power to the W2 Extend Valve Coil.
- E.) The Blue/Black 'W1 Retract' Wire sends 12vdc power to the W1 Retract Valve Coil. See Next Page for Hydraulic Flow Chart.

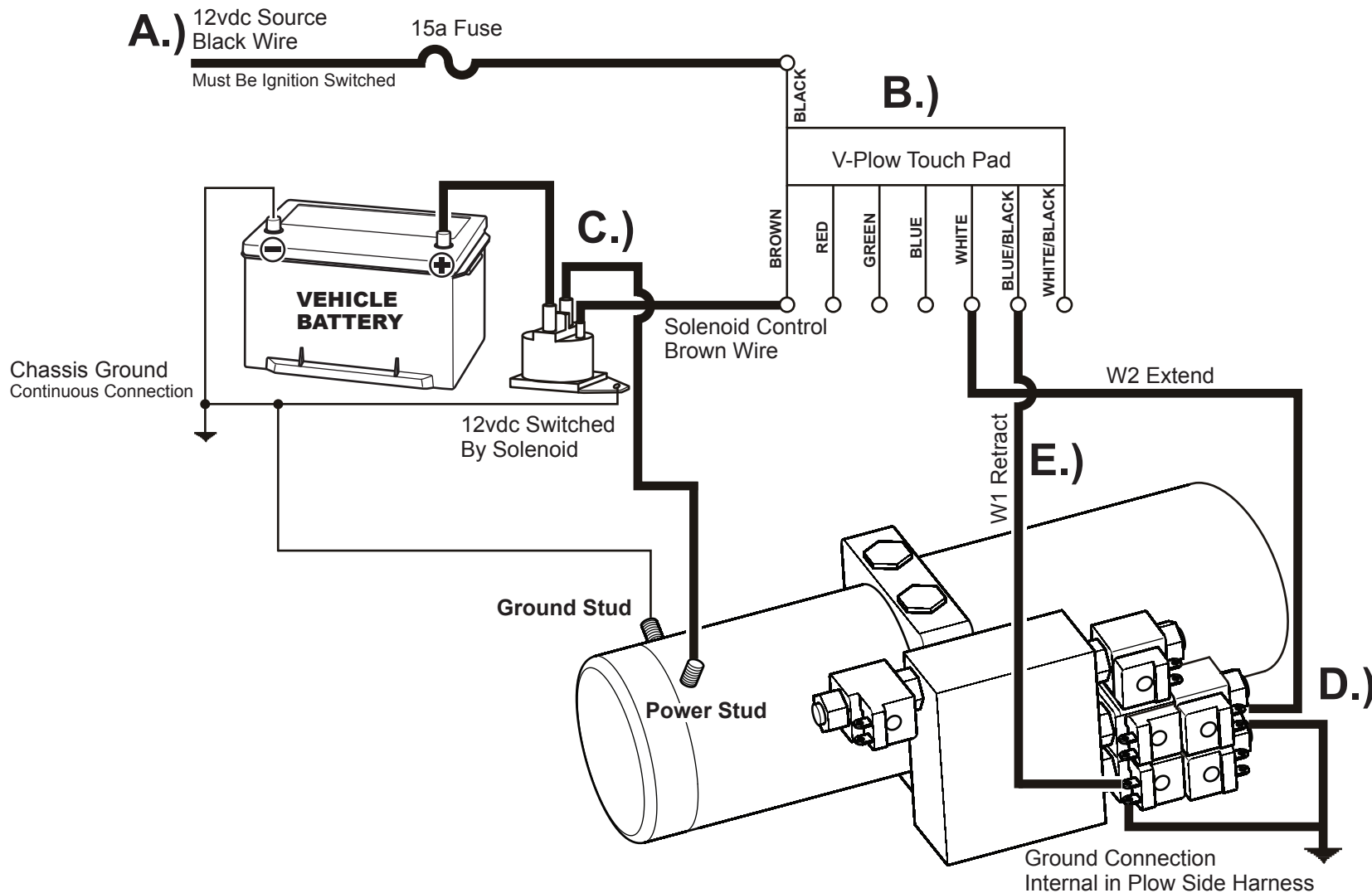

SNO-PRO V-PLOW w/SINGLE ACTING CYLINDERS & SPRING RETURN: LEFT ANGLE FUNCTION - HYDRAULIC

What Happens:

- A.) Left Angle Function is activated with Controller.
- B.) Brown Wire activates Motor Solenoid.
- C.) 12vdc Motor spins Pump developing pressure.
- D.) White Wire shifts 'W2 Angle Valve' to Wing Extend Position.
- E.) Pump pressure is supplied to 'W1' Port extending Right Angle Cylinder.
- F.) Blue/Black Wire shifts 'W1 Angle Valve' to Wing Retract Position, collapsing Left Angle Cylinder and returning fluid to Reservoir.

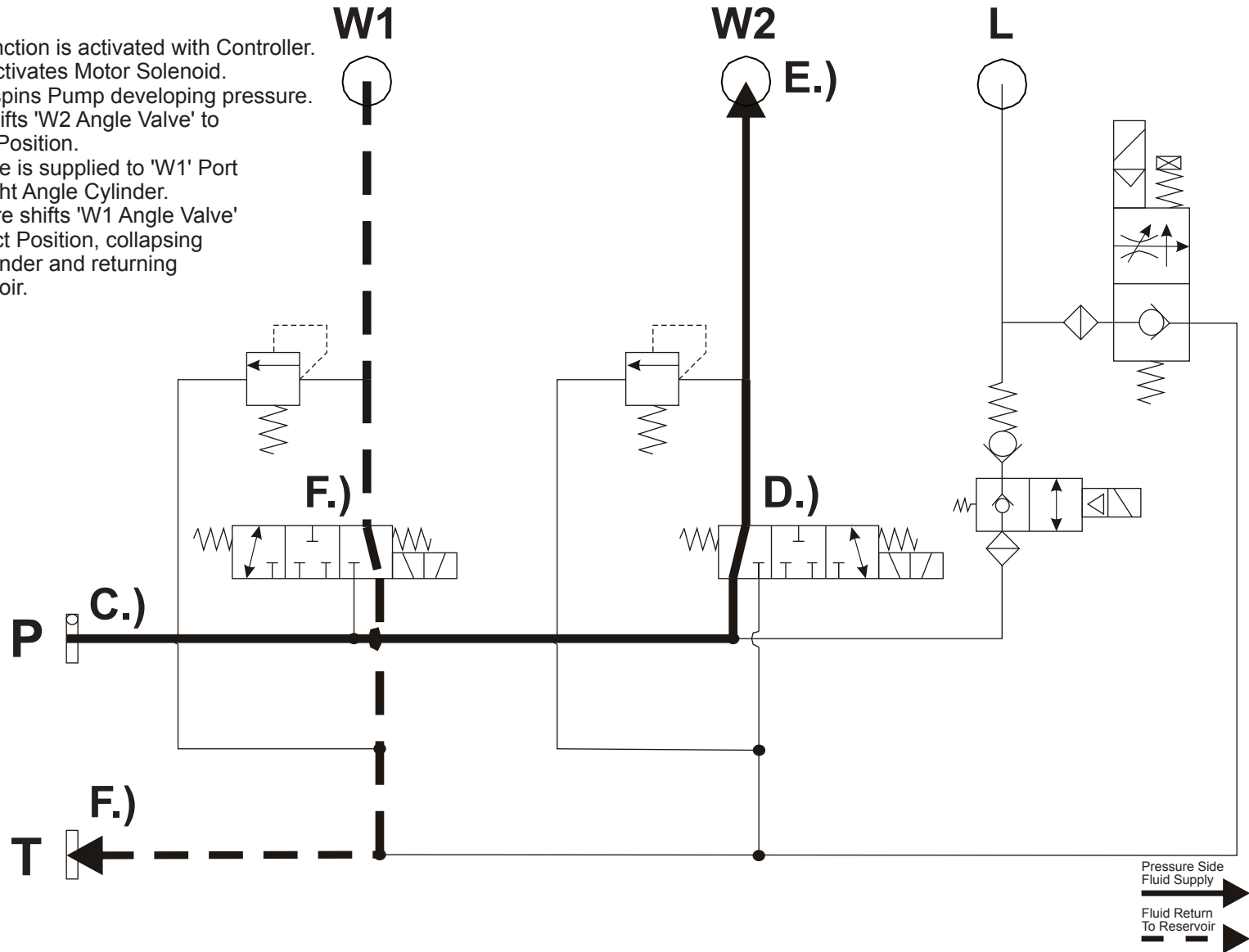

SNO-PRO V-PLOW w/SINGLE ACTING CYLINDERS & SPRING RETURN: RIGHT ANGLE FUNCTION - ELECTRICAL

What Happens:

- A.) Ignition 'On' energizes the Controller Power source sending 12vdc into the Controller. Touch Pad Power Switch must be in the 'On' position.
- B.) Pushing the 'Right Angle' button energizes the Blue 'W1 Extend' Wire, White/Black 'W2 Retract' Wire and the Brown 'Solenoid' Wire.
- C.) The Brown 'Solenoid' Wire closes the Solenoid Contacts and sends 12vdc power to the Pump Motor.
- D.) The Blue 'W1 Extend' Wire sends 12vdc power to the W1 Extend Valve Coil.
- E.) The White/Black 'W2 Retract' Wire sends 12vdc power to the W2 Retract Valve Coil. See Next Page for Hydraulic Flow Chart.

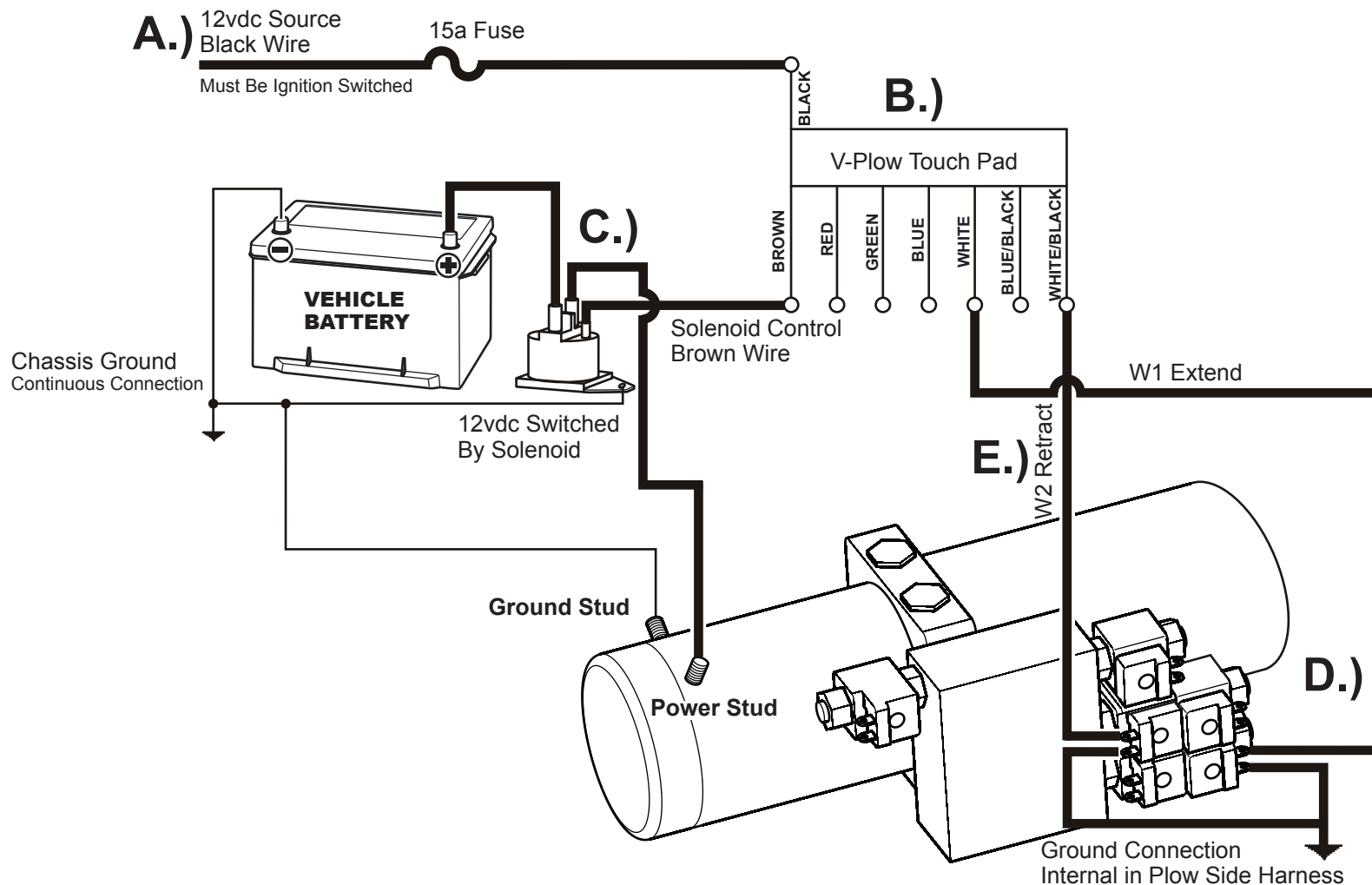

SNO-PRO V-PLOW w/SINGLE ACTING CYLINDERS & SPRING RETURN: RIGHT ANGLE FUNCTION - HYDRAULIC

What Happens:

- A.) Right Angle Function is activated with Controller.
- B.) Brown Wire activates Motor Solenoid.
- C.) 12vdc Motor spins Pump developing pressure.
- D.) Blue Wire shifts 'W1 Angle Valve' to Wing Extend Position.
- E.) Pump pressure is supplied to 'W1' Port extending Right Angle Cylinder.
- F.) Blue/Black Wire shifts 'W2 Angle Valve' to Wing Retract Position, collapsing Right Angle Cylinder and returning fluid to Reservoir.

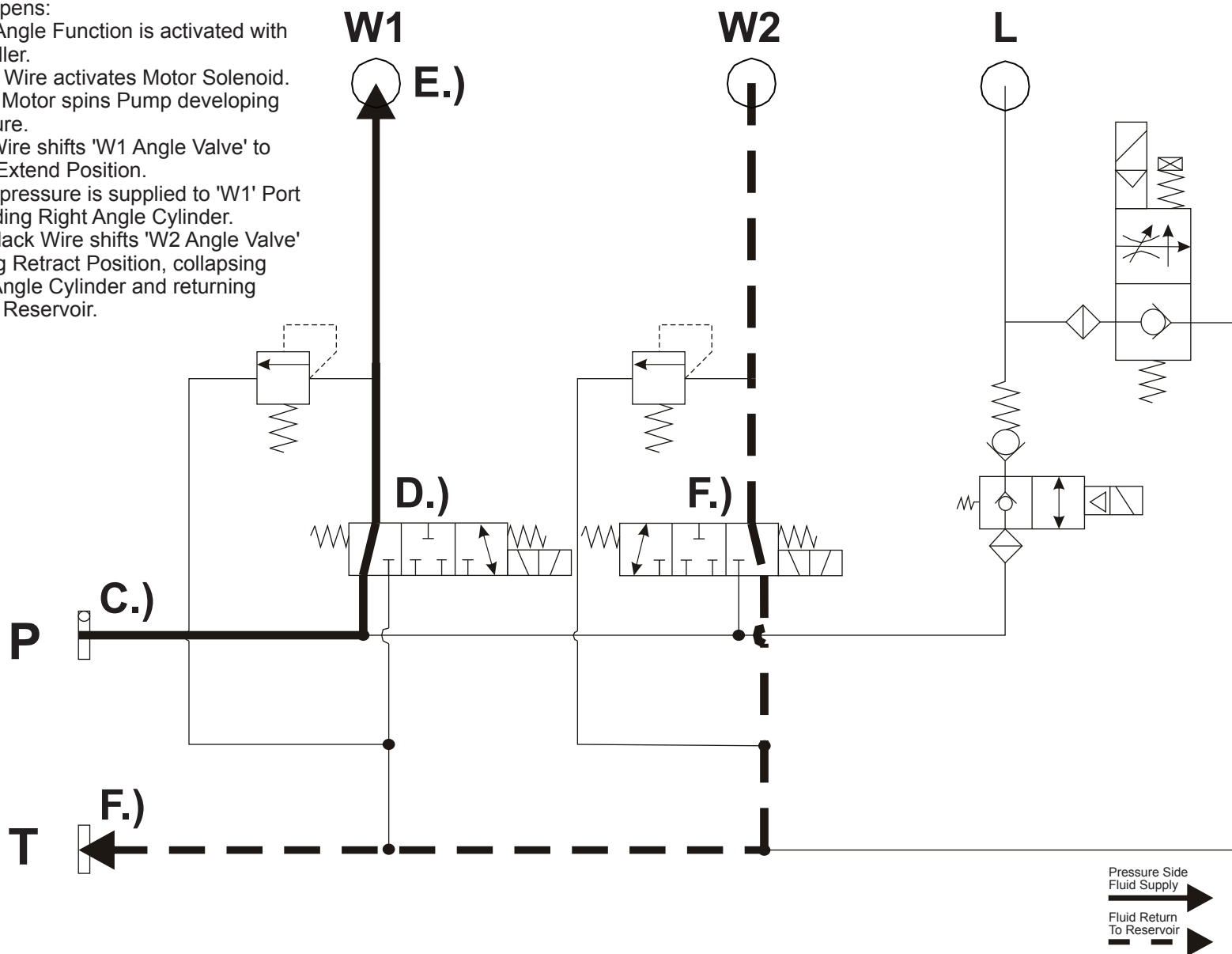

SNO-PRO V-PLOW w/SINGLE ACTING CYLINDERS & SPRING RETURN: LEFT WING EXTEND FUNCTION - ELECTRICAL

What Happens:

- A.) Ignition 'On' energizes the Controller Power source sending 12vdc into the Controller. Touch Pad Power Switch must be in the 'On' position.
- B.) Pushing the 'Left Extend' button energizes the Blue 'W1 Extend' Wire and the Brown 'Solenoid' Wire.
- C.) The Brown 'Solenoid' Wire closes the Solenoid Contacts and sends 12vdc power to the Pump Motor.
- D.) The Blue 'W1 Extend' Wire sends 12vdc power to the W1 Extend Valve Coil.
- E.) See Next Page for Hydraulic Flow Chart.

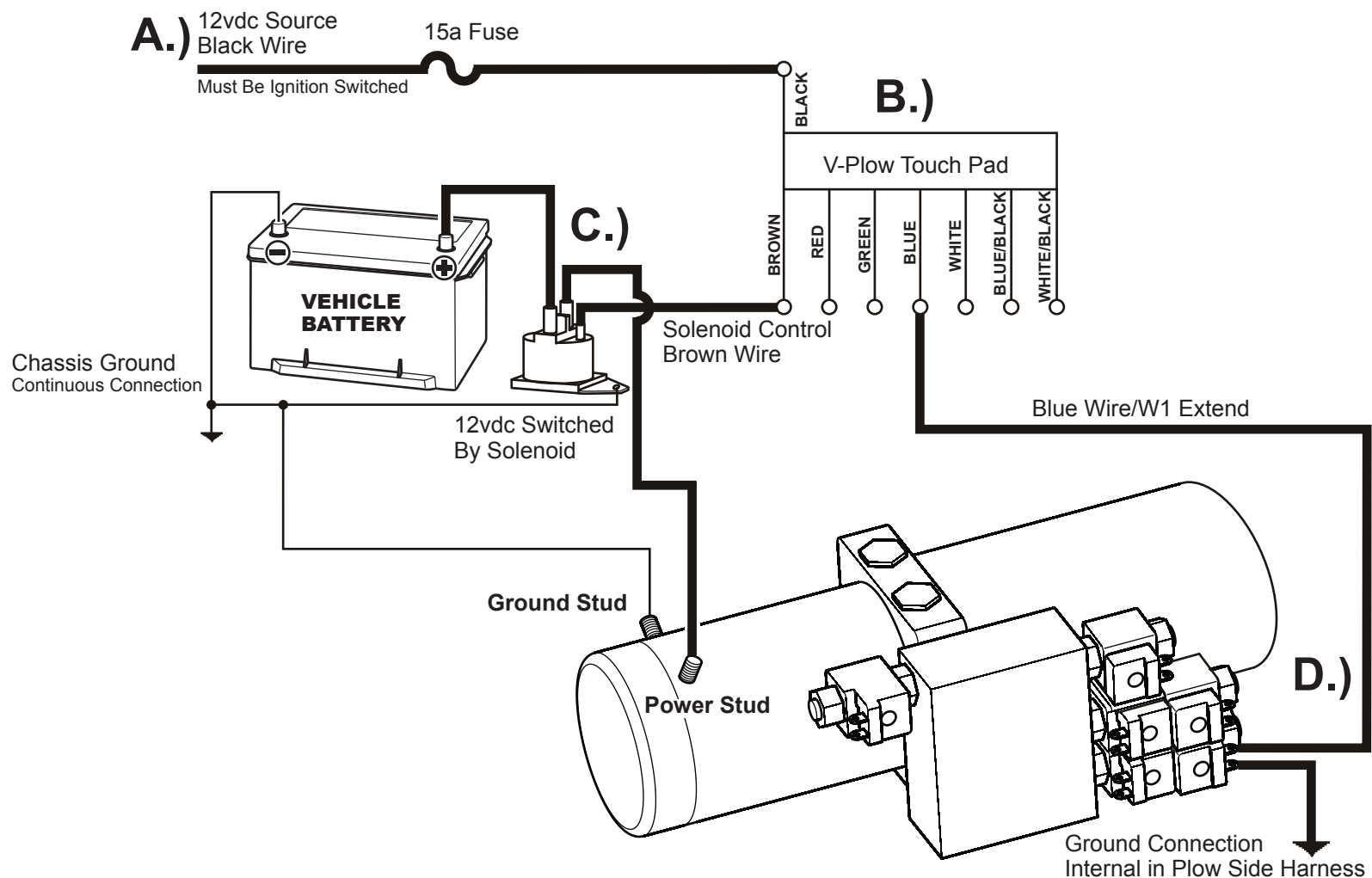

SNO-PRO V-PLOW w/SINGLE ACTING CYLINDERS & SPRING RETURN: LEFT WING EXTEND FUNCTION - HYDRAULIC

What Happens:

- A.) Left Wing Extend Function is activated with Controller.
- B.) Brown Wire activates Motor Solenoid.
- C.) 12vdc Motor spins Pump developing pressure.
- D.) Blue Wire shifts 'W1 Angle Valve' to Wing Extend Position.
- E.) Pump pressure is supplied to 'W1' Port extending Left Angle Cylinder.

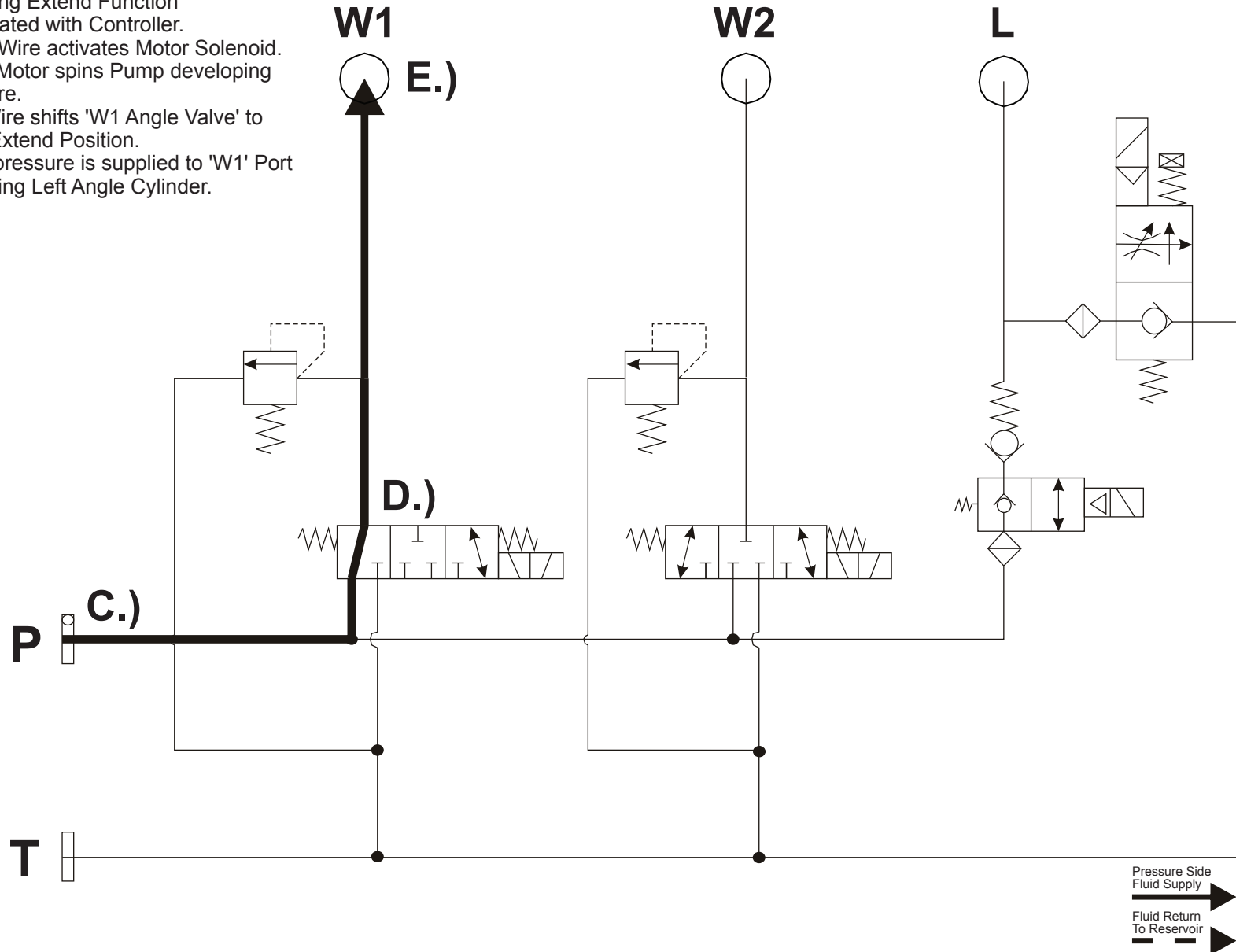

SNO-PRO V-PLOW w/SINGLE ACTING CYLINDERS & SPRING RETURN: RIGHT WING EXTEND FUNCTION - ELECTRICAL

What Happens:

- A.) Ignition 'On' energizes the Controller Power source sending 12vdc into the Controller. Touch Pad Power Switch must be in the 'On' position.
- B.) Pushing the 'Right Extend' button energizes the White 'W2 Extend' Wire and the Brown 'Solenoid' Wire.
- C.) The Brown 'Solenoid' Wire closes the Solenoid Contacts and sends 12vdc power to the Pump Motor.
- D.) The White 'W2 Extend' Wire sends 12vdc power to the W2 Extend Valve Coil.
- E.) See Next Page for Hydraulic Flow Chart.

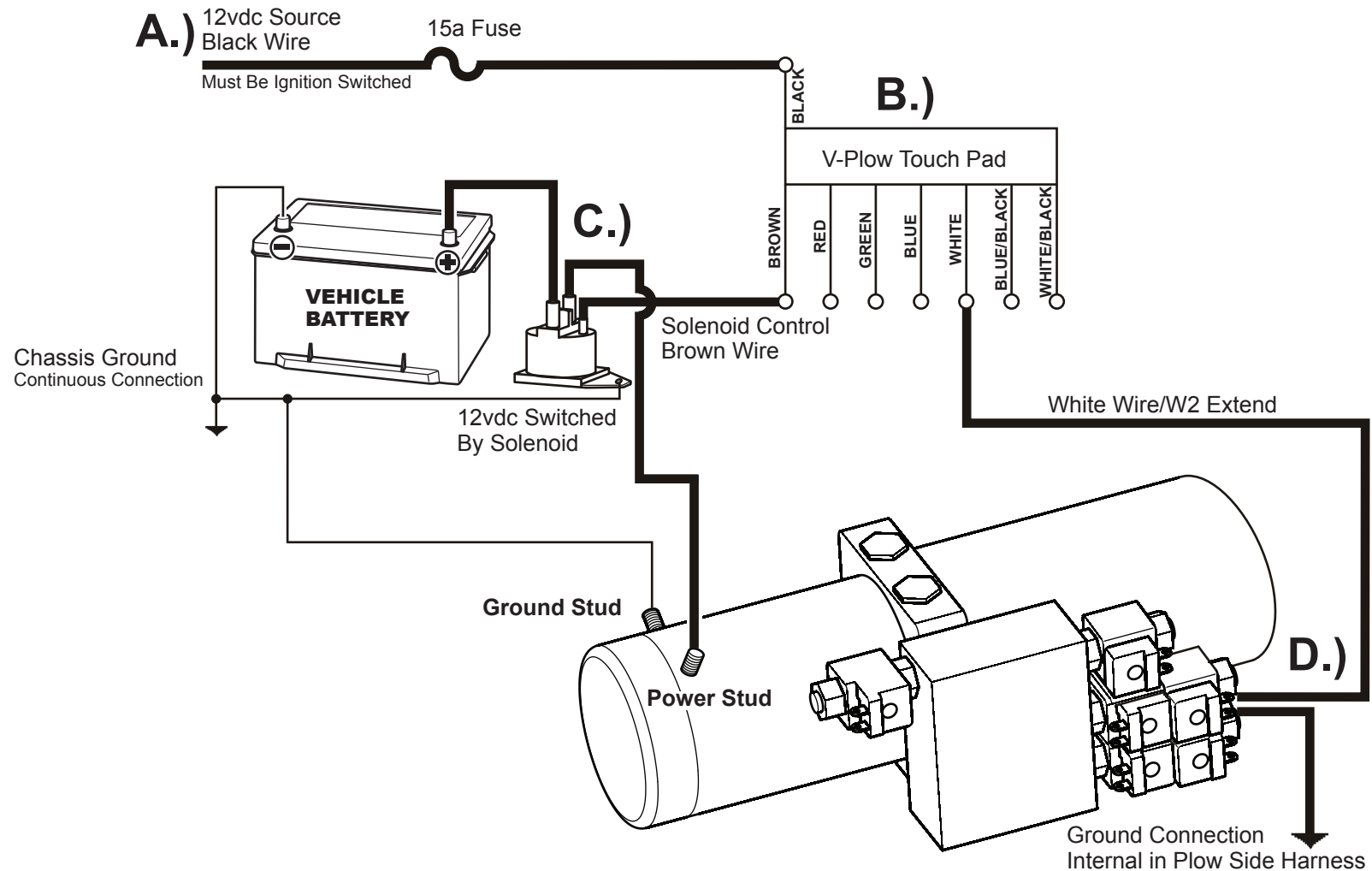

SNO-PRO V-PLOW w/SINGLE ACTING CYLINDERS & SPRING RETURN: RIGHT WING EXTEND FUNCTION - HYDRAULIC

What Happens:

- A.) Right Wing Extend Function is activated with Controller.
- B.) Brown Wire activates Motor Solenoid.
- C.) 12vdc Motor spins Pump developing pressure.
- D.) White Wire shifts 'W2 Angle Valve' to Wing Extend Position.
- E.) Pump pressure is supplied to 'W2' Port extending Right Angle Cylinder.

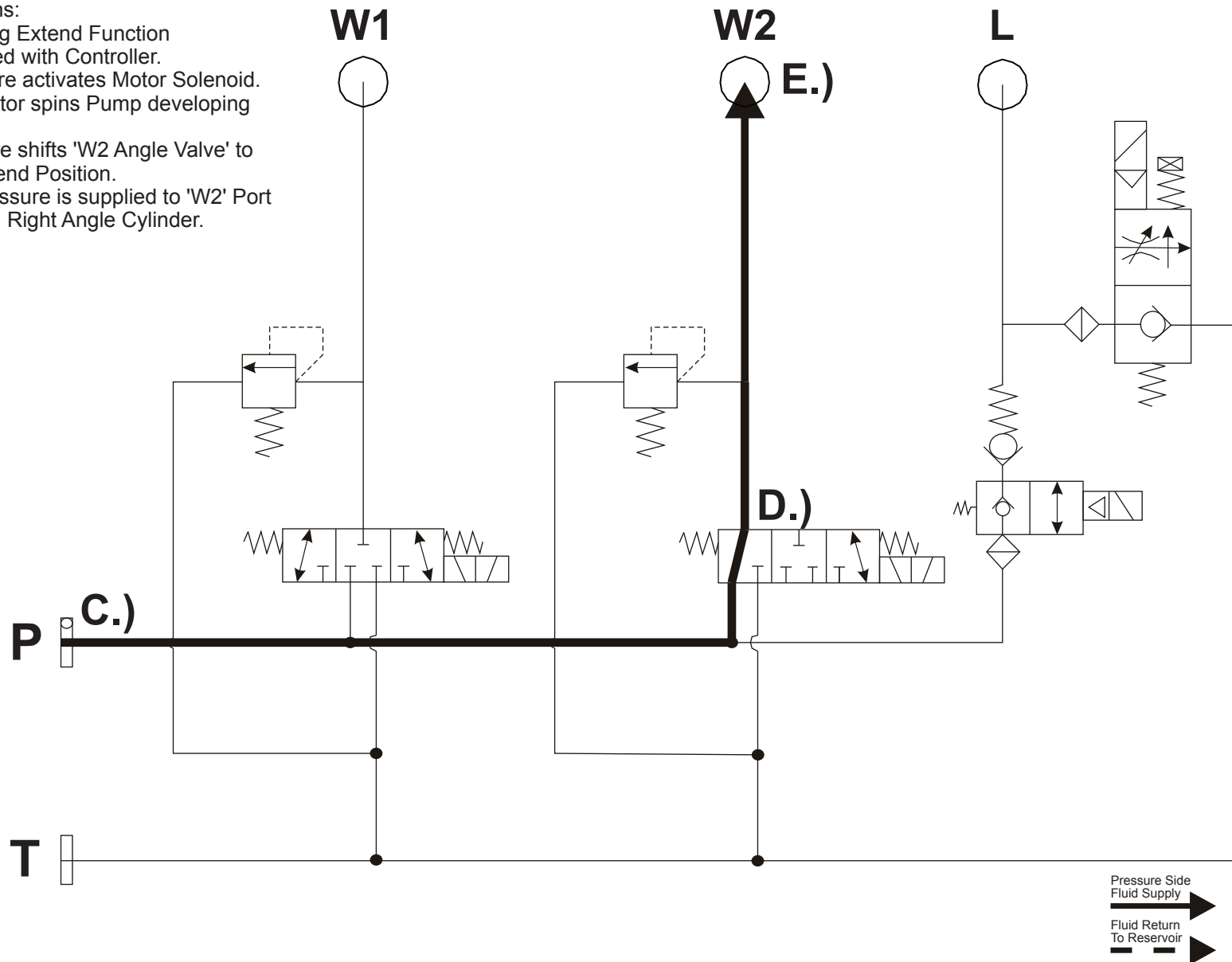

SNO-PRO V-PLOW w/SINGLE ACTING CYLINDERS & SPRING RETURN: LEFT WING RETRACT FUNCTION - ELECTRICAL

What Happens:

- A.) Ignition 'On' energizes the Controller Power source sending 12vdc into the Controller. Touch Pad Power Switch must be in the 'On' position.
- B.) Pushing the 'Left Retract' button energizes the Blue/Black 'W1 Retract' Wire.
- C.) The Blue/Black 'W1 Retract' Wire sends 12vdc power to the W1 Retract Valve Coil.
- D.) See Next Page for Hydraulic Flow Chart.

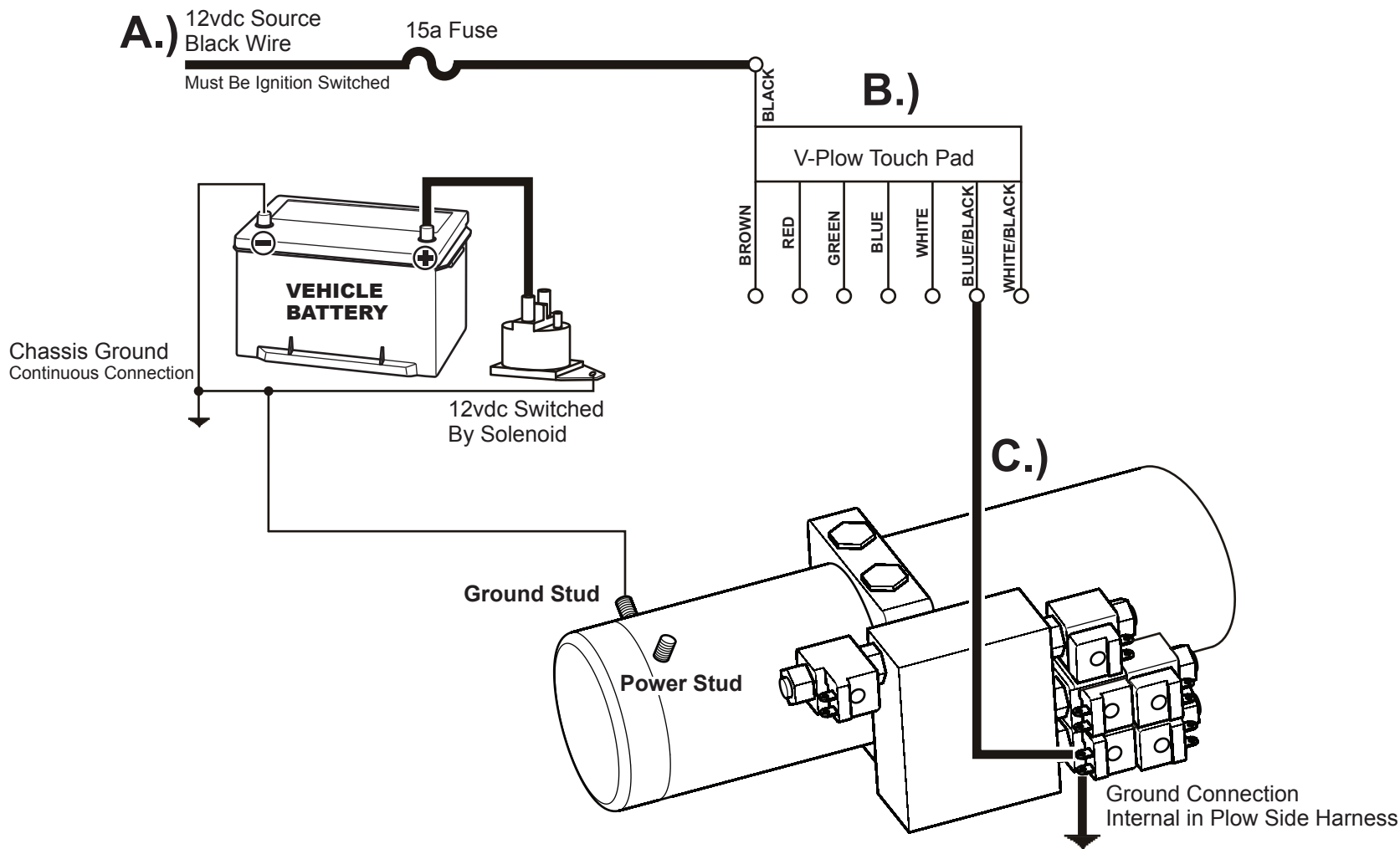

SNO-PRO V-PLOW w/SINGLE ACTING CYLINDERS & SPRING RETURN: LEFT WING RETRACT FUNCTION - HYDRAULIC

What Happens:

- A.) Left Wing Retract Function is activated with Controller.
- B.) Blue/Black Wire shifts 'W1 Angle Valve' to Wing Retract Position.
- C.) Fluid is returned from 'W1 Port' to Reservoir.

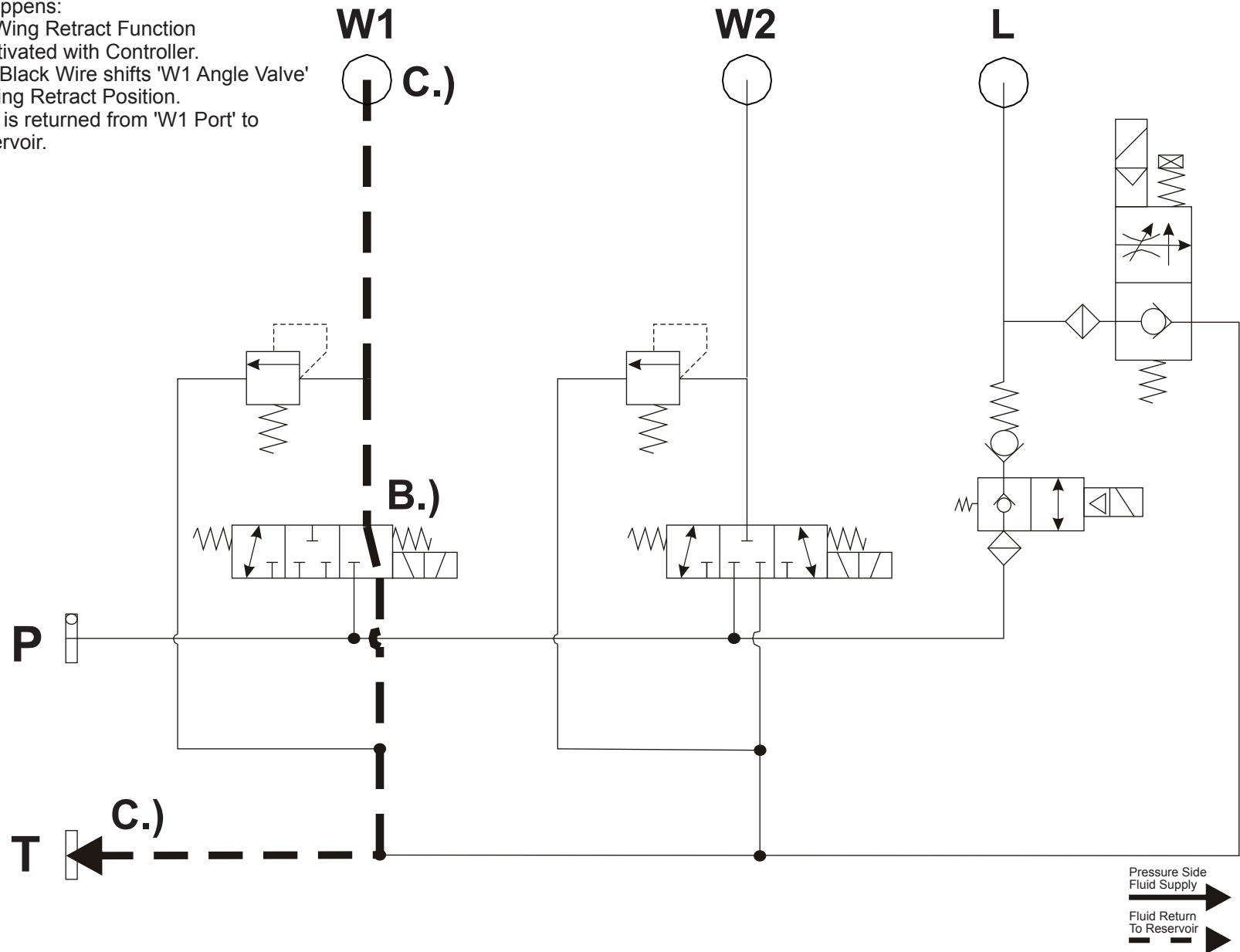

SNO-PRO V-PLOW w/SINGLE ACTING CYLINDERS & SPRING RETURN: RIGHT WING RETRACT FUNCTION - ELECTRICAL

What Happens:

- A.) Ignition 'On' energizes the Controller Power source sending 12vdc into the Controller. Touch Pad Power Switch must be in the 'On' position.
- B.) Pushing the 'Right Retract' button energizes the White/Black 'W2 Retract' Wire.
- C.) The White/Black 'W2 Retract' Wire sends 12vdc power to the Retract Valve Coil.
- D.) See Next Page for Hydraulic Flow Chart.

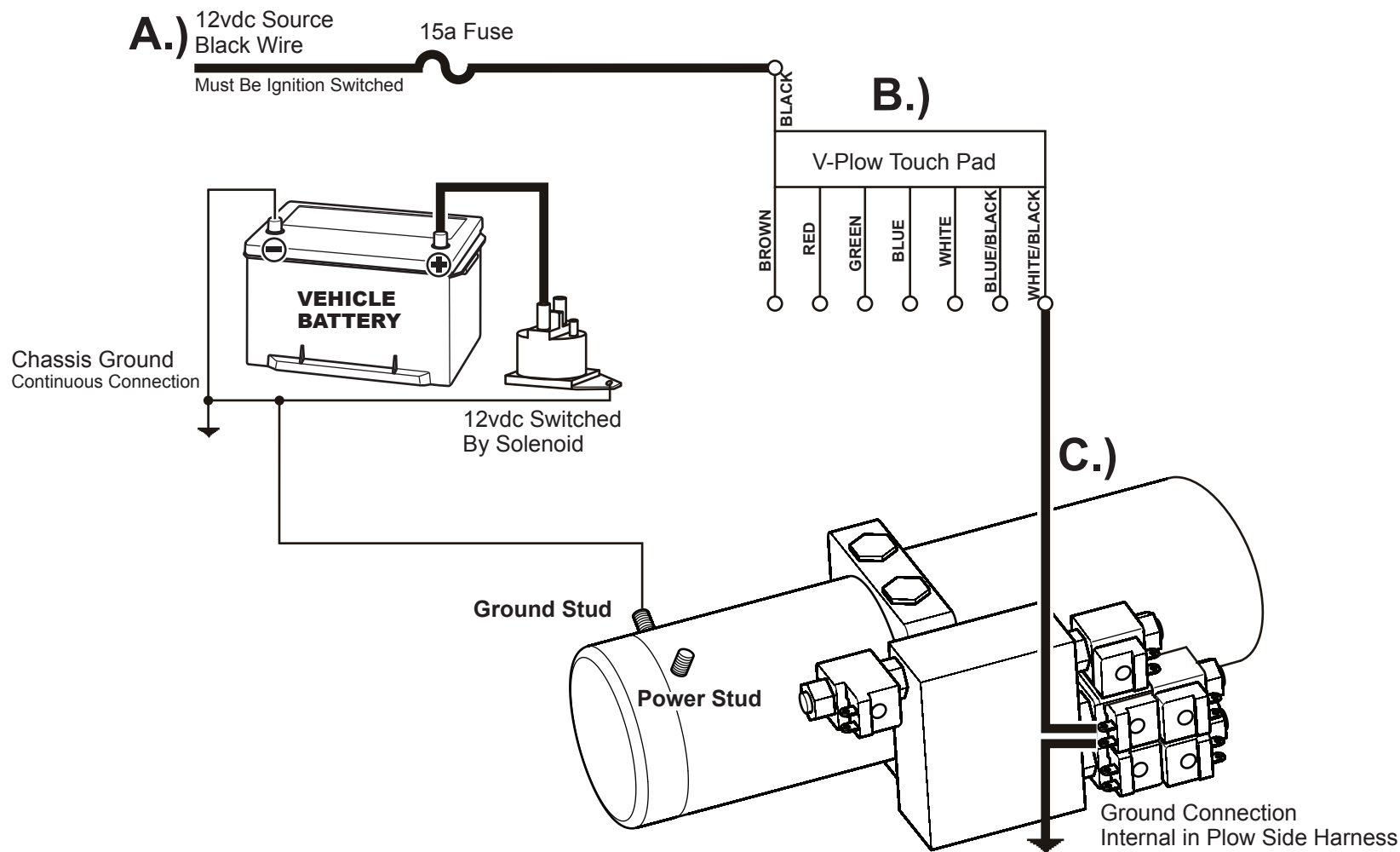

SNO-PRO V-PLOW w/SINGLE ACTING CYLINDERS & SPRING RETURN: RIGHT WING RETRACT FUNCTION - HYDRAULIC

What Happens:

- A.) Right Wing Retract Function is activated with Controller.
- B.) White/Black Wire shifts 'W2 Angle Valve' to Wing Retract Position.
- C.) Fluid is returned from 'W2' Port to Reservoir.

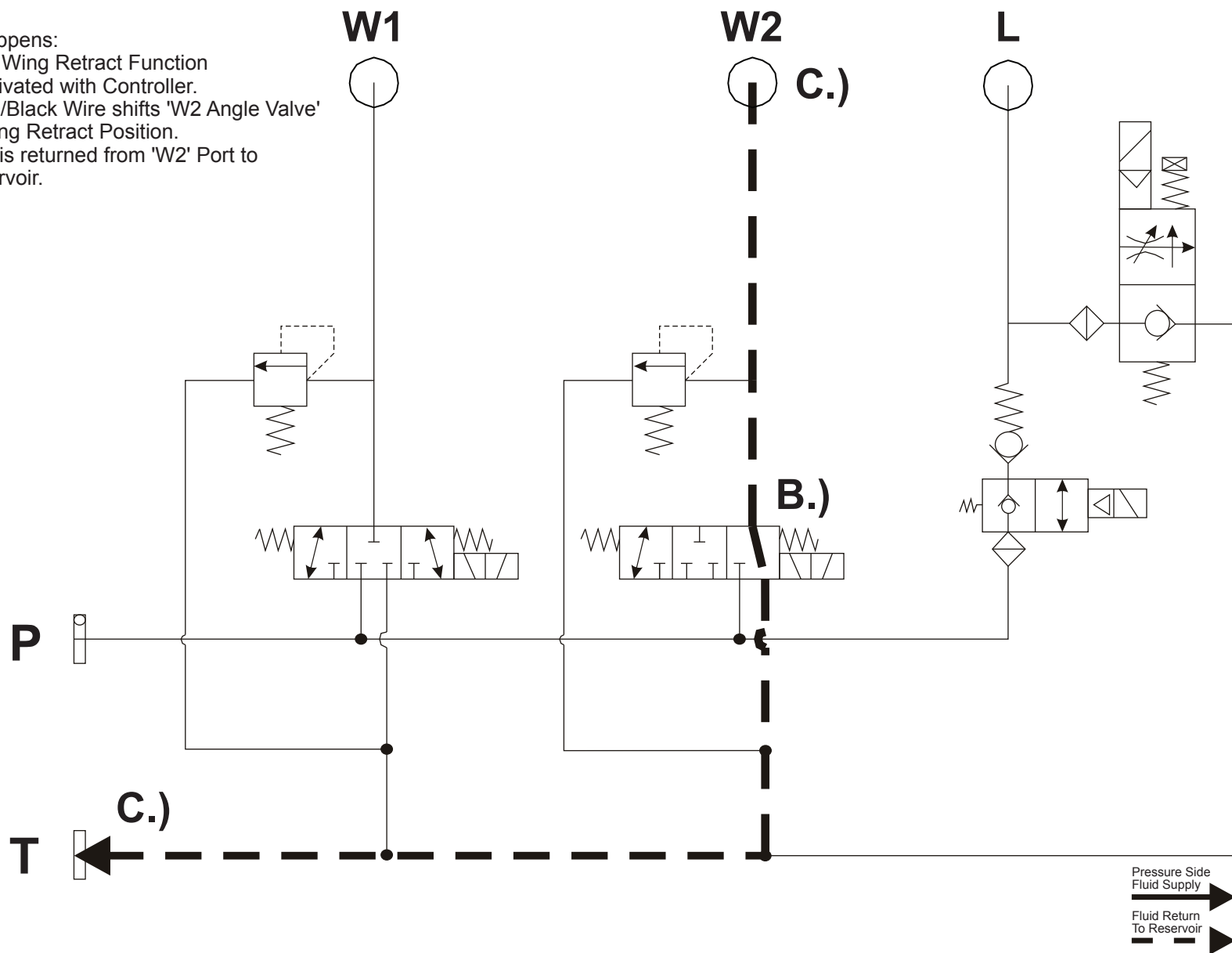

SNO-PRO V-PLOW w/SINGLE ACTING CYLINDERS & SPRING RETURN: PLOW LIFT FUNCTION - ELECTRICAL

What Happens:

- A.) Ignition 'On' energizes the Controller Power source sending 12vdc into the Controller. Touch Pad Power Switch must be in the 'On' position.
- B.) Pushing the 'Plow Lift' Button energizes the Red 'Lift' Wire and the Brown 'Solenoid' Wire.
- C.) The Brown 'Solenoid' Wire closes the Solenoid Contacts and sends 12vdc power to the Pump Motor.
- D.) The Red 'Lift' Wire sends 12vdc power to the Plow Lift Valve Coil.
- E.) See Next Page for Hydraulic Flow Chart.

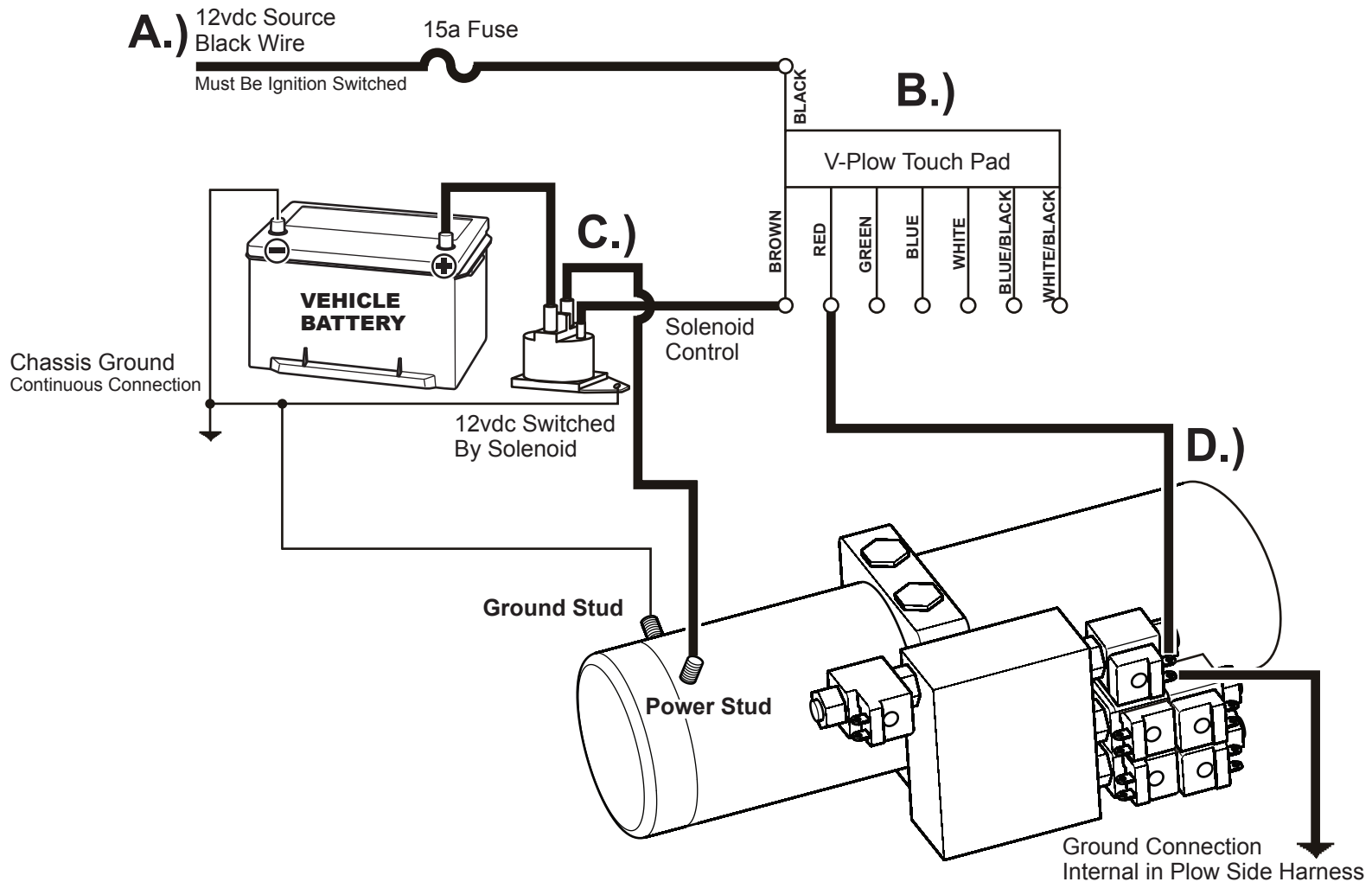

SNO-PRO V-PLOW w/SINGLE ACTING CYLINDERS & SPRING RETURN: PLOW LIFT FUNCTION - HYDRAULIC

What Happens:

- A.) Plow Lift Function is activated with Controller.
- B.) Brown Wire activates Motor Solenoid.
- C.) 12vdc Motor spins Pump developing pressure.
- D.) Red Wire shifts 'Lift' Valve to 'Open' position.
- E.) Pump pressure is supplied to 'L' Port extending Lift Cylinder and raising Plow.

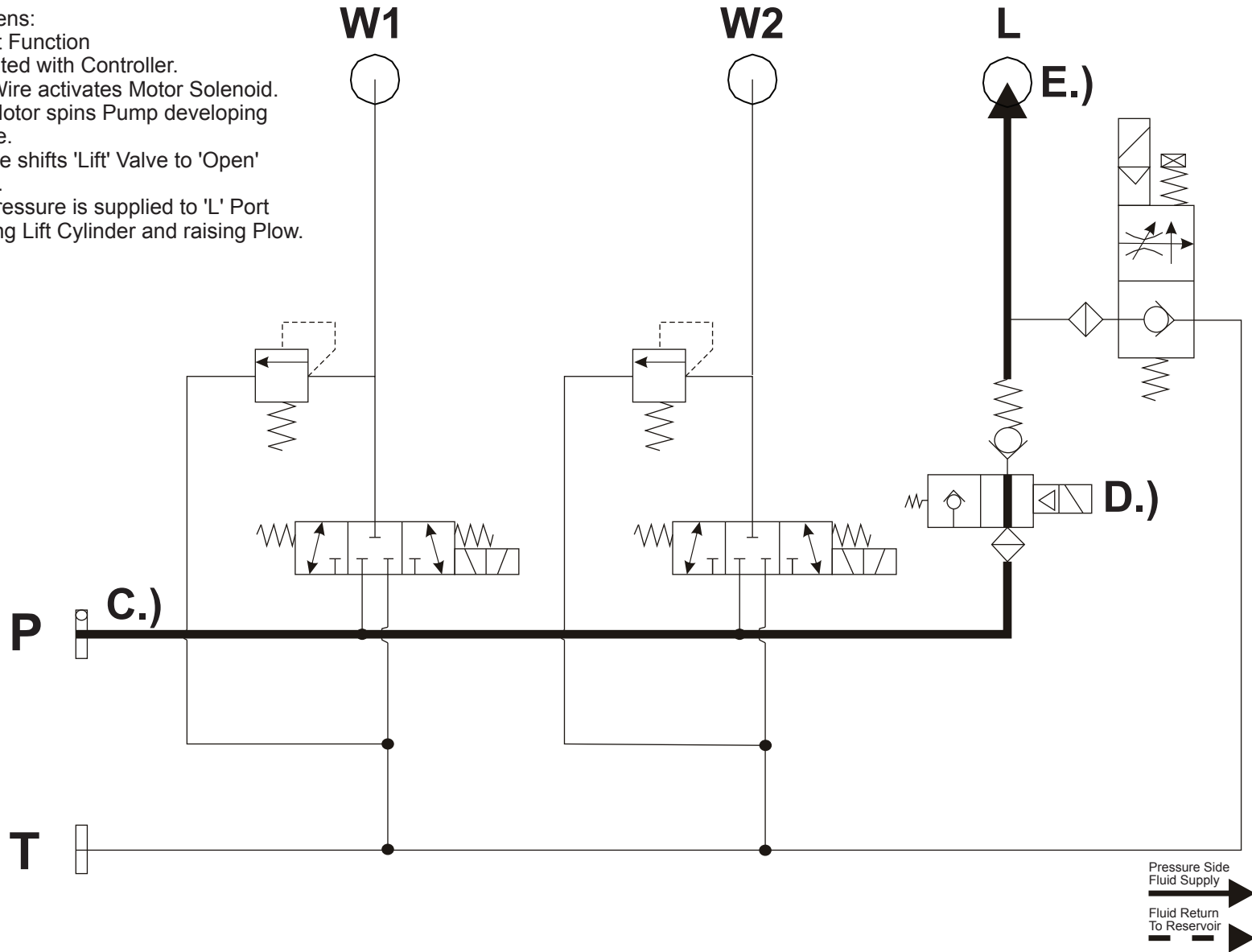

SNO-PRO V-PLOW w/SINGLE ACTING CYLINDERS & SPRING RETURN: PLOW FLOAT FUNCTION - ELECTRICAL

What Happens:

- A.) Ignition 'On' energizes the Controller Power source sending 12vdc into the Controller. Touch Pad Power Switch must be in the 'On' position.
- B.) Pushing the 'Plow Float' Button energizes the Green 'Float' Wire.
- C.) The Green 'Plow Float' Wire sends 12vdc power to the Plow Float Valve Coil.
- D.) See Next Page for Hydraulic Flow Chart.

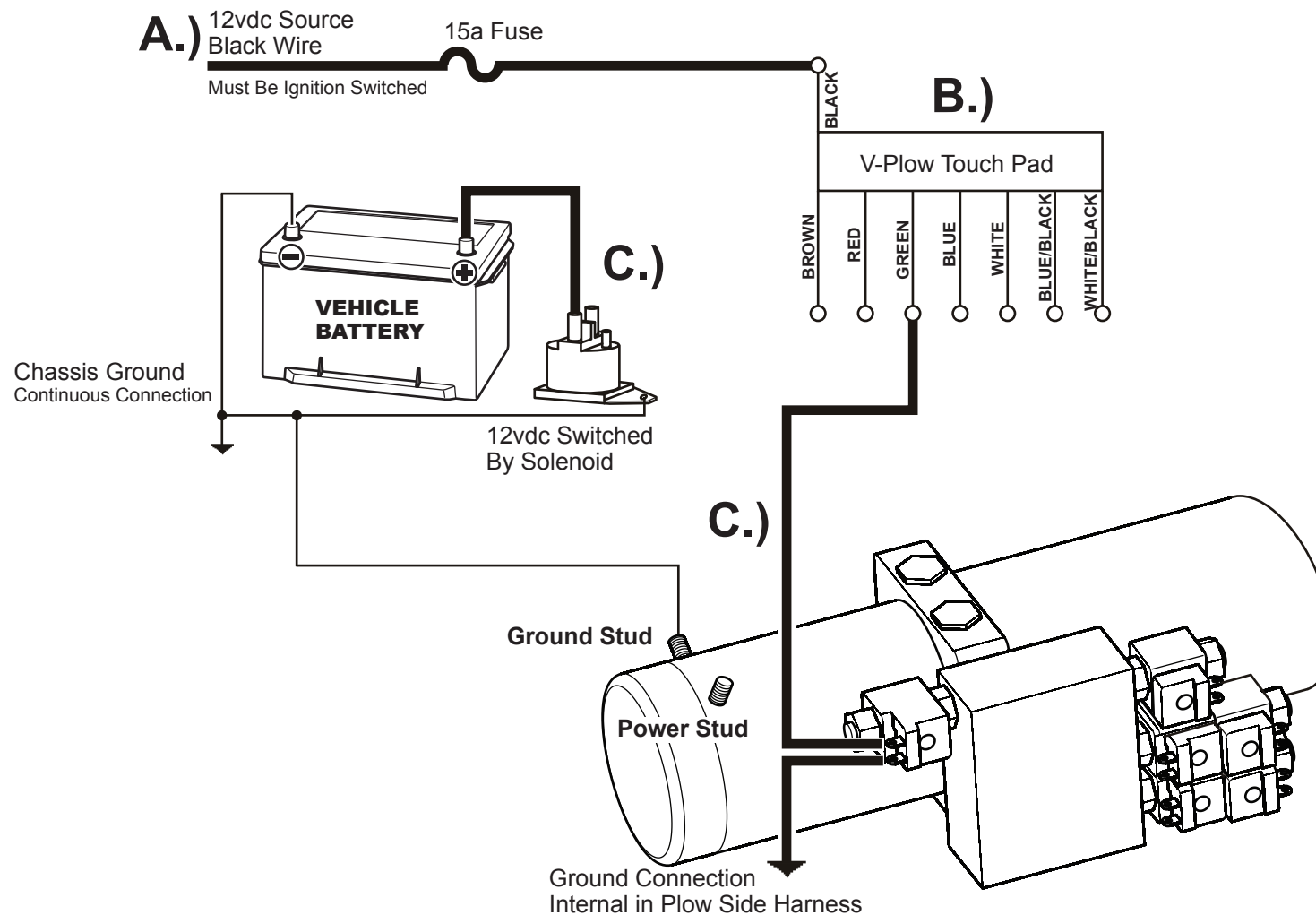

SNO-PRO V-PLOW w/SINGLE ACTING CYLINDERS & SPRING RETURN: PLOW FLOAT FUNCTION - HYDRAULIC

What Happens:

- A.) Plow Float Function is activated with Controller.
- B.) Green Wire shifts Float Valve to 'Open' position.
- C.) Fluid returns from 'L' Port back to Reservoir.

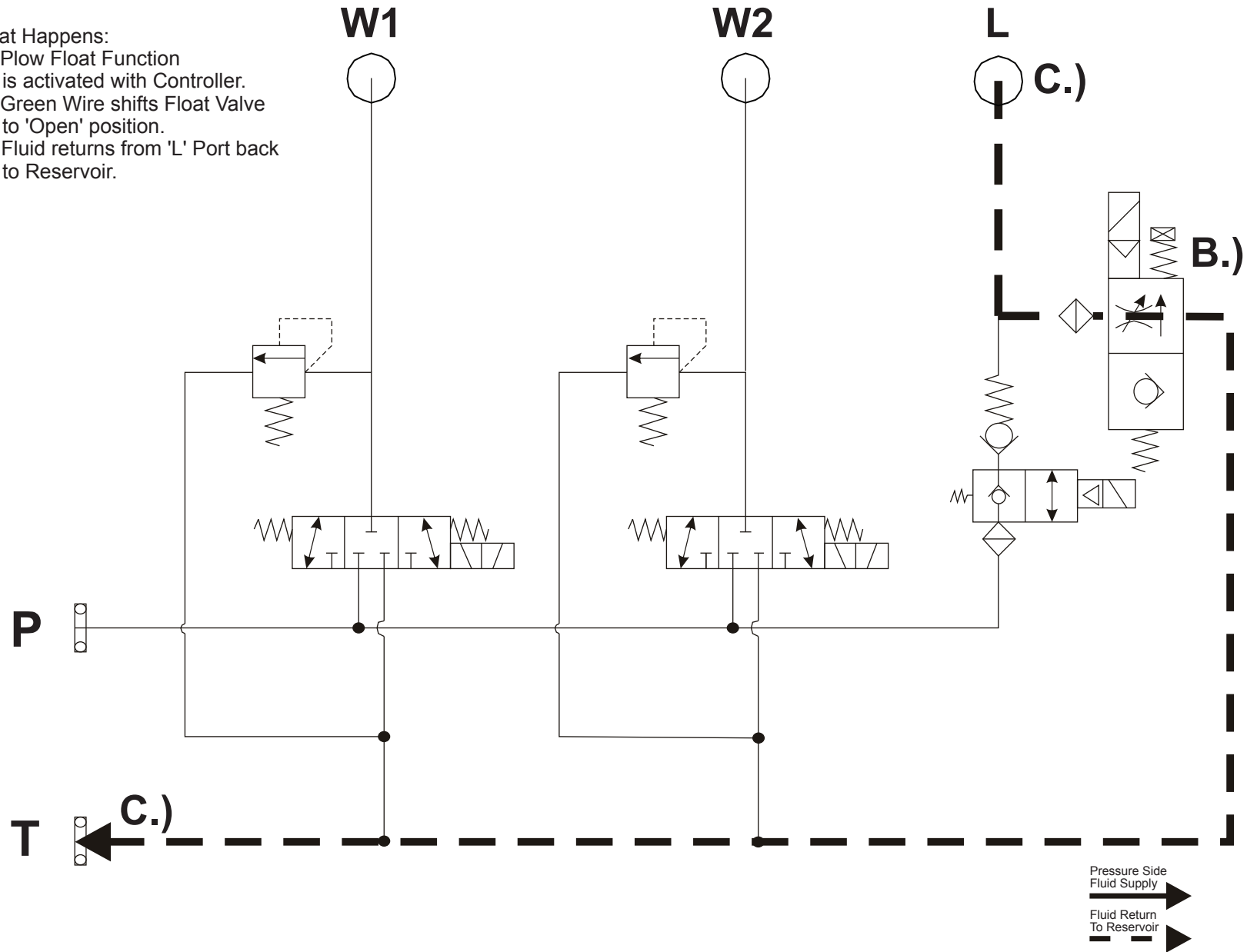

POLY TRIP EDGE V-PLOW ELECTRIC/HYDRAULIC POWER UNIT WITH MANIFOLD

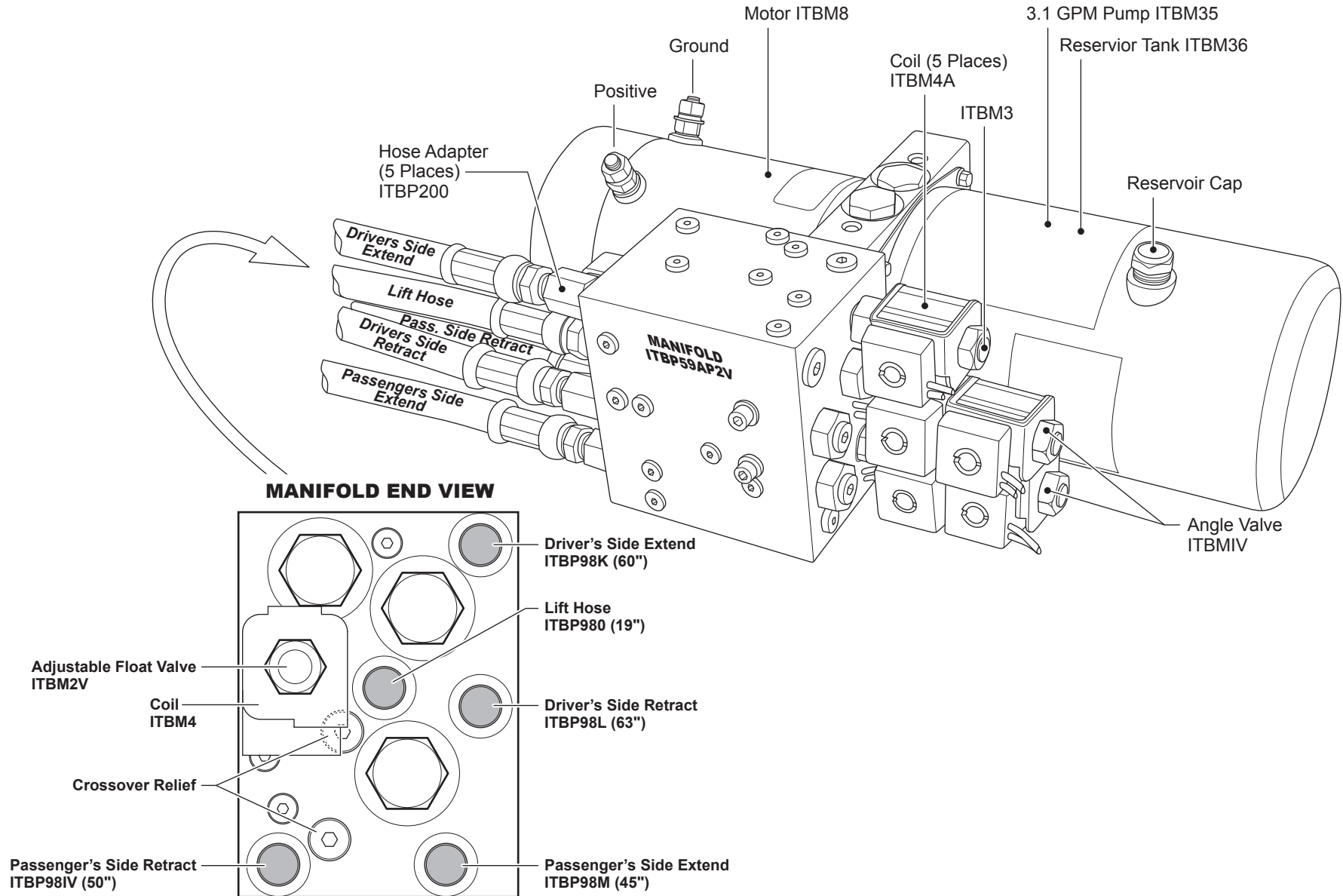

CURTIS UNIVERSAL PLOW SIDE HARNESS SCHEMATIC P/N: 1UHP

L-1, L-2, R-1 & R-2 - 6-Prong Molded

1. LOW BEAM (Lt. GREEN/BLACK) = (E)
2. WHITE/RED (COMMON) = (A)
3. HIGH BEAM (YELLOW/BLACK) = (F)
4. PARK (GREY) = (D)
5. LEFT/RIGHT TURN (VIOLET/PINK) = (C)
6. NOT USED = (B)

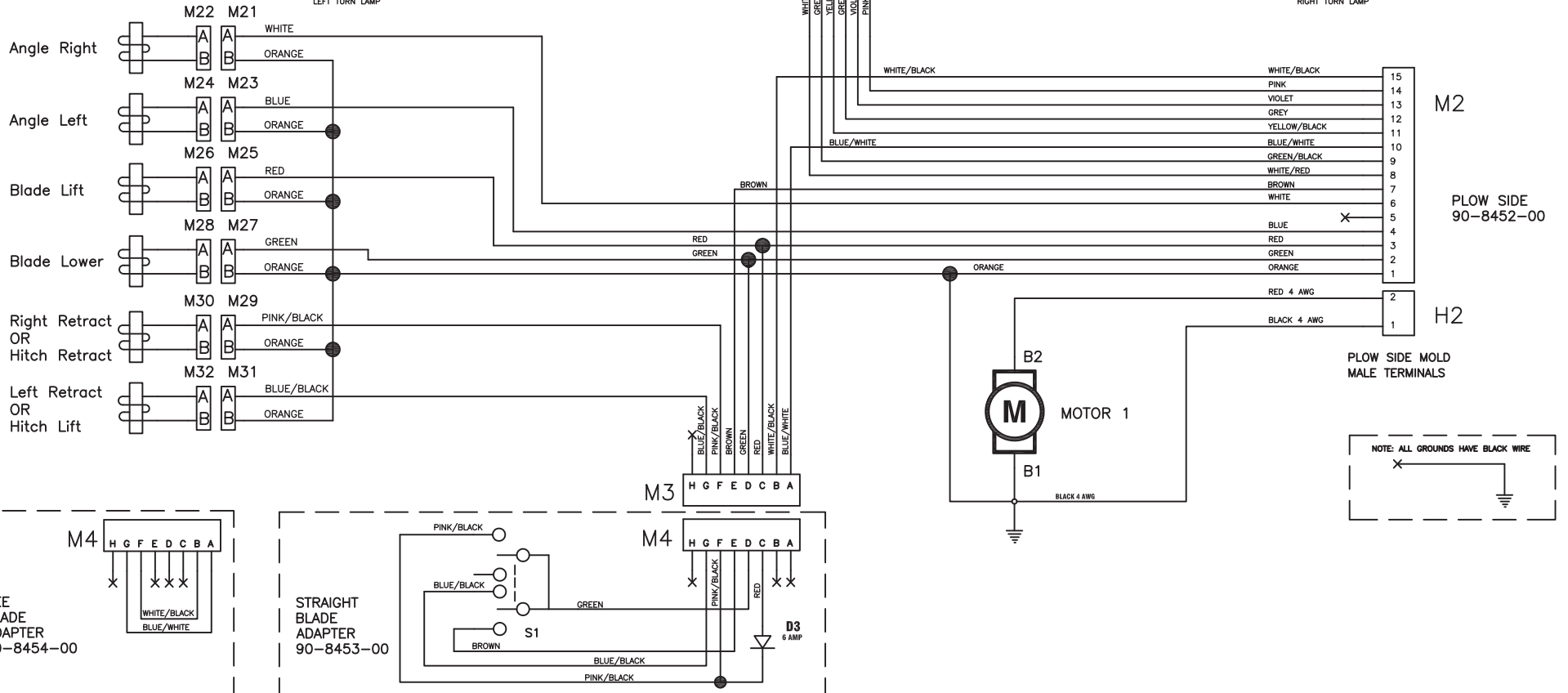
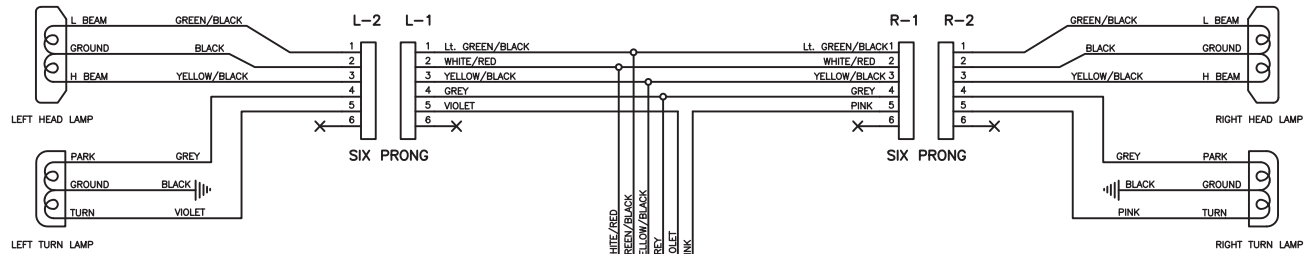

CURTIS UNIVERSAL VEHICLE SIDE HARNESS LAYOUT P/N: 1UHT

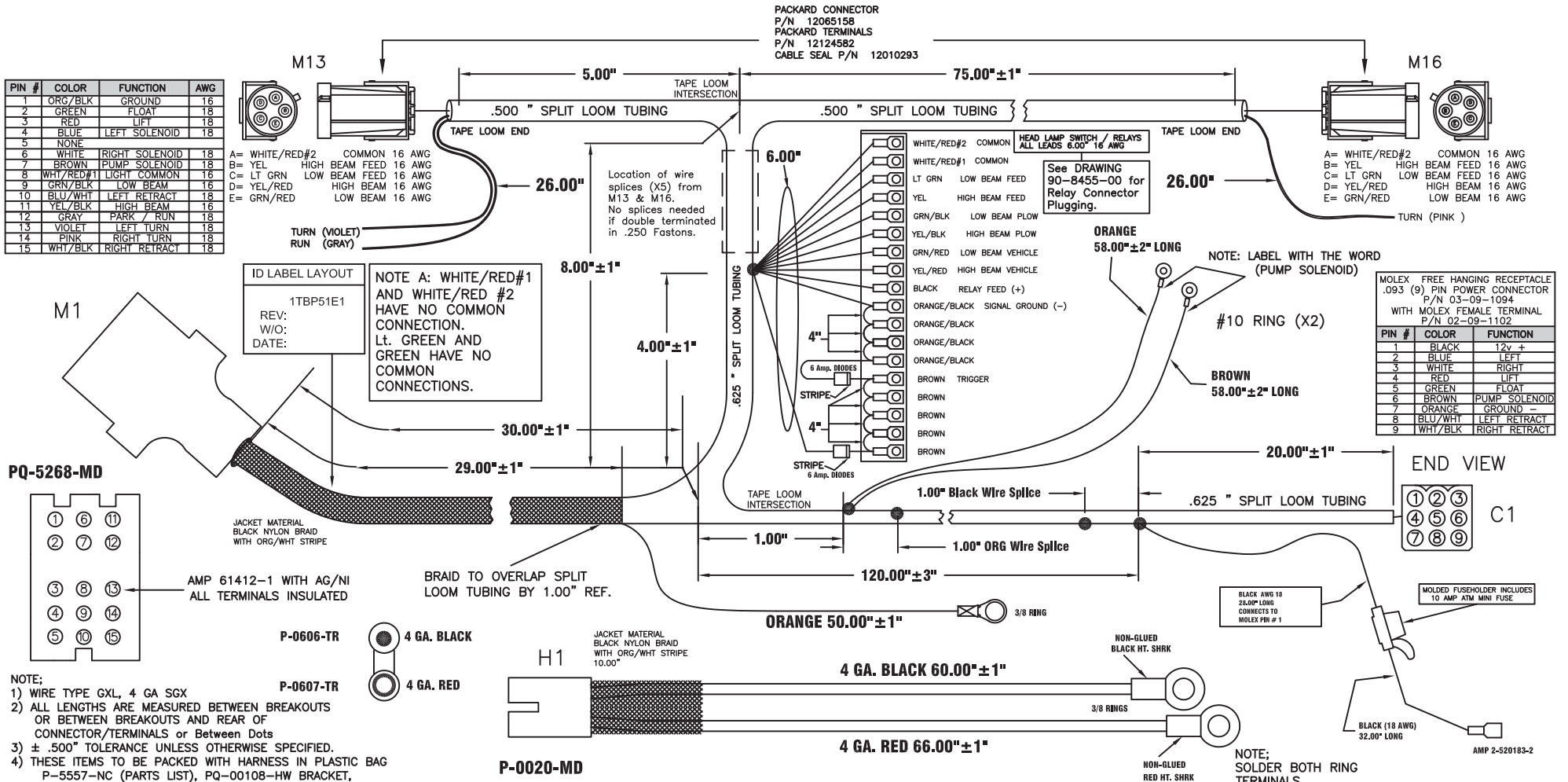

PIN #	COLOR	FUNCTION	AWG
1	ORG/BLK	GROUND	16
2	GREEN	FLOAT	18
3	RED	LIFT	18
4	BLUE	LEFT SOLENOID	18
5	NONE		
6	WHITE	RIGHT SOLENOID	18
7	BROWN	PUMP SOLENOID	18
8	WHI/RED#1	LIGHT COMMON	16
9	ORG/BLK	LOW BEAM	16
10	BLU/WHI	LEFT RETRACT	18
11	YEL/BLK	HIGH BEAM	16
12	GRAY	PARK / RUN	18
13	VIOLET	LEFT TURN	18
14	PINK	RIGHT TURN	18
15	WHI/BLK	RIGHT RETRACT	18

A= WHITE/RED#2 COMMON 16 AWG
 B= YEL HIGH BEAM FEED 16 AWG
 C= LT GRN LOW BEAM FEED 16 AWG
 D= YEL/RED HIGH BEAM FEED 16 AWG
 E= GRN/RED LOW BEAM FEED 16 AWG

ID LABEL LAYOUT
 1TBP51E1
 REV:
 W/O:
 DATE:

NOTE A: WHITE/RED#1 AND WHITE/RED #2 HAVE NO COMMON CONNECTION. LT. GREEN AND GREEN HAVE NO COMMON CONNECTIONS.

See DRAWING 90-8455-00 for Relay Connector Plugging.

MOLEX FREE HANGING RECEPTACLE .093 (9) PIN POWER CONNECTOR P/N 03-09-1094 WITH MOLEX FEMALE TERMINAL P/N 02-09-1102

PIN #	COLOR	FUNCTION
1	BLACK	12v +
2	BLUE	LEFT
3	WHITE	RIGHT
4	RED	LIFT
5	GREEN	FLOAT
6	BROWN	PUMP SOLENOID
7	ORANGE	GROUND -
8	BLU/WHI	LEFT RETRACT
9	WHI/BLK	RIGHT RETRACT

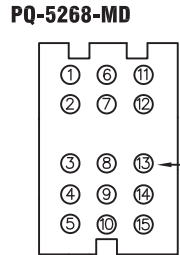

JACKET MATERIAL BLACK NYLON BRAID WITH ORG/WHI STRIPE

BRAID TO OVERLAP SPLIT LOOM TUBING BY 1.00" REF.

JACKET MATERIAL BLACK NYLON BRAID WITH ORG/WHI STRIPE 10.00"

- NOTE:**
- 1) WIRE TYPE GXL, 4 GA SGX
 - 2) ALL LENGTHS ARE MEASURED BETWEEN BREAKOUTS OR BETWEEN BREAKOUTS AND REAR OF CONNECTOR/TERMINALS or Between Dots
 - 3) ± .500" TOLERANCE UNLESS OTHERWISE SPECIFIED.
 - 4) THESE ITEMS TO BE PACKED WITH HARNESS IN PLASTIC BAG P-5557-NC (PARTS LIST), PQ-00108-HW BRACKET, P-1462-01, PQ-0050-BT, PQ-0051-BT, PQ-0052-BT AND (5) PQ-00105-PC. 4 GAUGE, RED SGX, 90.00" ± 1.00" WITH A SOLDERED AND HEAT SHRUNK 3/8" RING AND BLUNT CUT ON OTHER END WITH LOOSE AMP 33471 SLID ON COILED AND TIE WRAPPED WIRE
 - 5) ALL SPECIFIED MATERIAL CAN BE SUBSTITUTED WITH CURTIS APPROVED EQUIVALENTS
 - 6) ALL LIKE COLORS HAVE COMMON CONNECTION, EXCEPT WHITE/RED#1 & #2, Lt. GREEN & GREEN- SEE NOTE A. (ALSO SEE SCHEMATIC 90-8451-SCH)
 - 7) CONTROL WIRE MOLD BOOT TO BE ATTACHED OVER BRAID
 - 8) ALL TERMINALS IN MOLDS TO BE GREASED
 - 9) BRAID TO EXTEND OVER STRAIN RELIEF OF ALL MOLDS
 - 10) APPLY HEAT SHRINK OVER ALL DIODES

LEGEND:

- = NON Insul. 630 Metri-Pack (F) Pack P/N 12015870 (2.0-1.0)
- = #10 RING COUPLER
- = 3/8 ID RING COUPLER "MOLEX - ETC" (4 AWG.)
- = 3/8 ID RING COUPLER "MOLEX - ETC" (16-22 AWG.)

CURTIS PLOW SIDE HARNESS JACK ADAPTER FOR HYDRAULIC JACK EQUIPPED SNOWPLOWS P/N: 1UHJA

LEGEND:

 = Insul. FEMALE COUPLERS .250 FASTON (Single)

NOTE:
CRIMP AND SOLDER
BOTH SPLICES

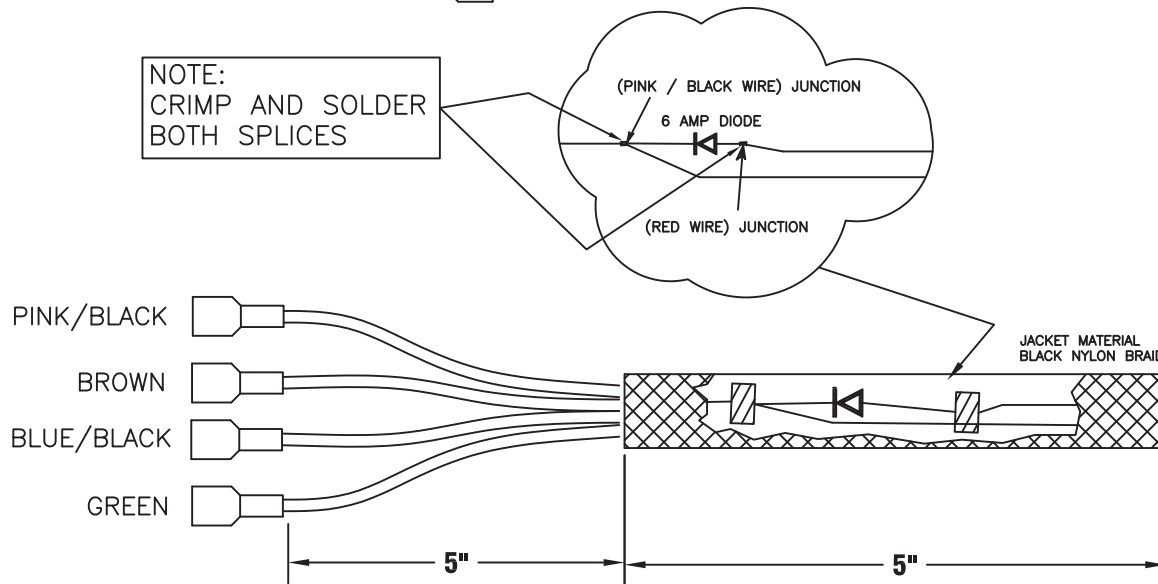

PACKARD GT 280 CONNECTOR P/N 15326655 TERMINAL 15304731 (M) SEAL P/N 12191223 CAVITY PLUG 15305170			
PIN #	COLOR	FUNCTION	AWG
A	Cavity Plug	N/A	N/A
B	Cavity Plug	N/A	N/A
C	RED	LIFT	18
D	GREEN	LOWER	18
E	BROWN	PUMP	18
F	PINK/BLACK	Hitch Retract	18
G	BLUE/BLACK	Hitch Lift	18
H	Cavity Plug	N/A	N/A



Packard Electric Connector
P/N 15326655
Packard Electric Terminals
P/N 15304731 (M)
Cable Seal
P/N 12191223 (TAN)
CAVITY PLUG 15305170

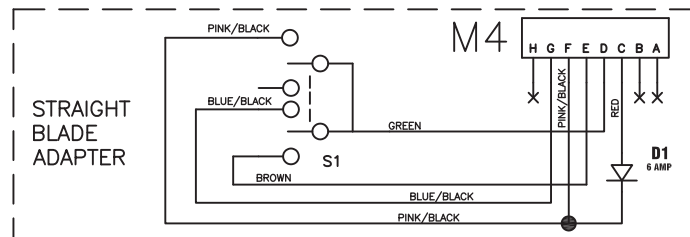

- 1) ALL WIRE GPT
- 2) ALL LENGTHS ARE MEASURED BETWEEN BREAKOUTS OR BETWEEN BREAKOUTS AND REAR OF CONNECTOR/TERMINALS
- 3) ± .500" TOLERANCE UNLESS OTHERWISE SPECIFIED
- 4) ALL SPECIFIED MATERIAL CAN BE SUBSTITUTED WITH CURTIS APPROVED EQUIVALENTS.

CURTIS PLOW SIDE HARNESS V-PLOW ADAPTER P/N: 1UHVA

PACKARD GT 280 CONNECTOR P/N 15326655			
TERMINAL 15304731 (M) SEAL P/N 12191223			
CAVITY PLUG 15305170			
M4			
PIN #	COLOR	FUNCTION	AWG
A	BLUE/WHITE	L Retract	18
B	WHITE/BLACK	R Retract	16
C	Cavity Plug	N/A	N/A
D	Cavity Plug	N/A	N/A
E	Cavity Plug	N/A	N/A
F	WHITE/BLACK	R Retract	16
G	BLUE/WHITE	L Retract	18
H	Cavity Plug	N/A	N/A

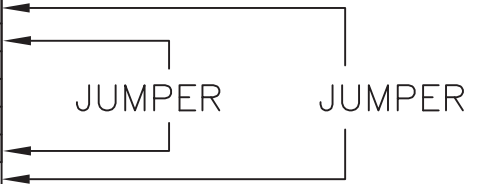

BLUE/WHITE 3.5"

WHITE/BLACK 3.5"

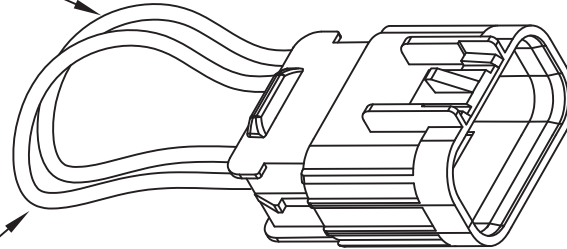

M4

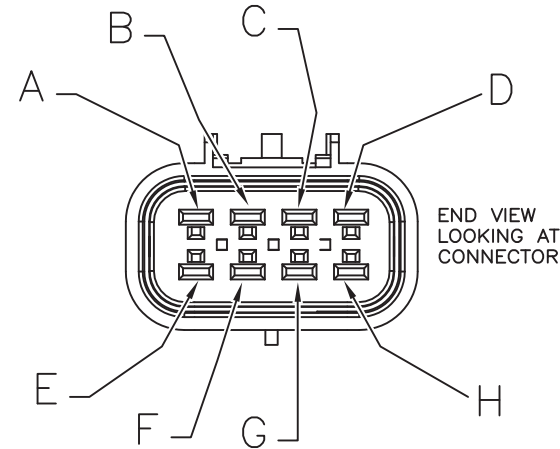

Packard Electric Connector
P/N 15326655
Packard Electric Terminals
P/N 15304731 (M)
Cable Seal
P/N 12191223 (TAN)
CAVITY PLUG 15305170

- 1) ALL WIRE GPT
- 2) ALL LENGTHS ARE MEASURED BETWEEN BREAKOUTS OR BETWEEN BREAKOUTS AND REAR OF CONNECTOR/TERMINALS
- 3) ± .500" TOLERANCE UNLESS OTHERWISE SPECIFIED
- 4) ALL SPECIFIED MATERIAL CAN BE SUBSTITUTED WITH CURTIS APPROVED EQUIVALENTS.

CURTIS VEHICLE SIDE HARNESS RELAY CONNECTOR CONNECTIONS

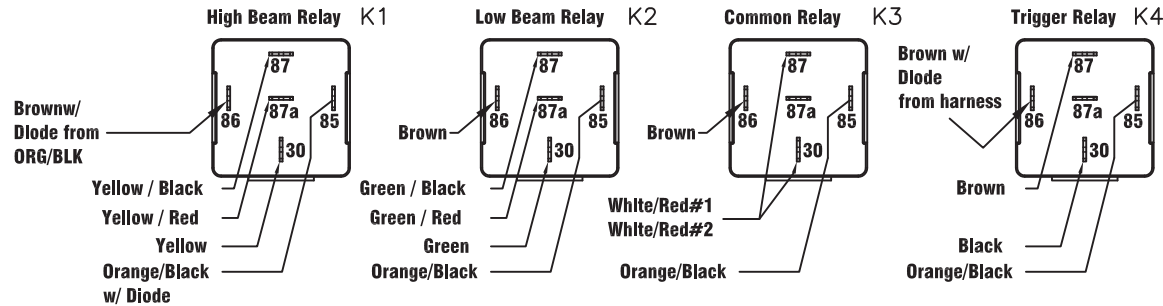

FRONT VIEW
 LOOKING AT
 PINNING FACE
 (X4)

All Terminals Plug To Relay Connectors
 (X4 Shown Below)

Relay Connector
 P/N 12033871
 TPA
 P/N 12033872

No Markings on Relay Connectors
 -Use Markings on Relays to Determine
 Proper Plugging of Relay Connectors

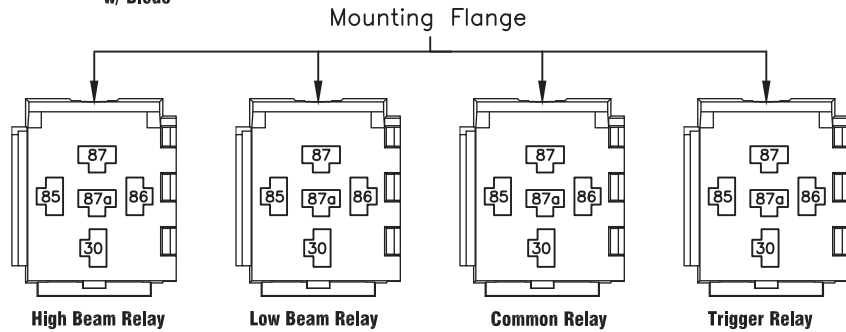

FRONT VIEW
 LOOKING AT
 PINNING FACE
 (X4)

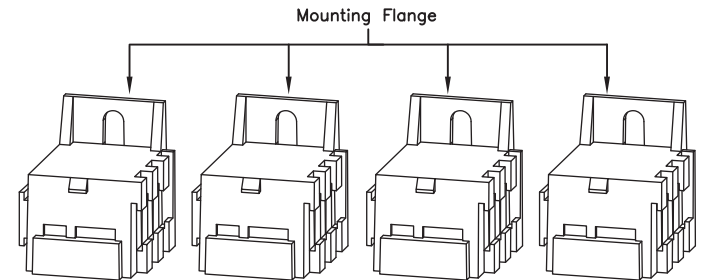

Ref. Drawing # 90-8451-00
 Curtis Vehicle Side ALT with 4 Relay

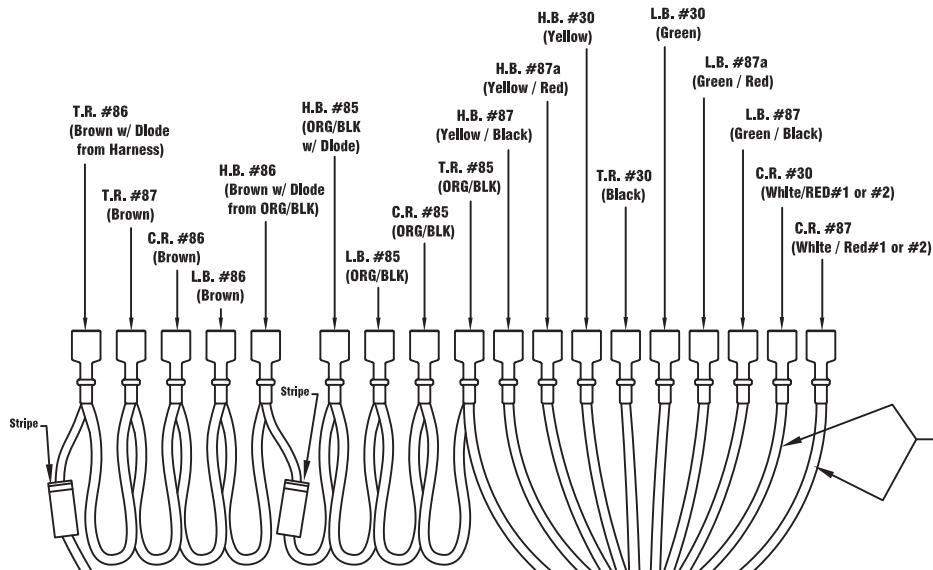

EITHER WHITE/RED WIRE
 MAY PLUG TO EITHER C.R. #30
 or C.R. #87
 WHITE/RED#1 & WHITE/RED#2
 ARE INTERCHANGEABLE

Vehicle Side Harness
 Plow Headlights / Vehicle Headlights Terminals

TROUBLESHOOTING INDEX - BY PROBLEM

Section A: Hydraulic System

- 1 Motor runs, but no Plow functions.
- 2 Motor runs, but all functions are slow.
- 3 Motor runs, but Blade raises slowly or not at all.
- 4 Motor runs, but Blade does not lower.
- 5 Blade lowers in neutral position.
- 6 Blade will not angle in one or both directions, lift and lower functions are Ok.
- 7 Blade will not remain angled.
- 8 Motor runs, but Jack Leg will not extend.
- 9 No Jack functions, Motor does not run.
- 10 Jack does not retract.

Section B: Electrical System

- 1 Pump Motor will not run.
- 2 Pump Motor runs continually.
- 3 Plow will not raise.
- 4 Plow will not lower.
- 5 Plow will not angle right.
- 6 Plow will not angle left.
- 7 Left & right fuctions are reversed.
- 8 Raise & lower functions are reversed.
- 9 Plow will not remain in 'Float' position.
- 10 Plow Jack Leg will not extend.
- 11 Plow Jack Leg will not retract.
- 12 Plow Jack Leg will not retract when Plow is raised.
- 13 Plow raises when Jack Leg is retracting.
- 14 Battery goes dead when vehicle is off.
- 15 Battery goes dead when vehicle is running.

Section C: Lighting Electrical System

- 1 No Lights on vehicle or Plow.
- 2 Plow Lights will not come on.
- 3 Plow Lights function, but vehicle lights will not come on.
- 4 High and Low beam reversed on Plow.
- 5 High beam indicator not functioning properly.
- 6 Headlight fuse blows after installing new Plow lights.
- 7 Plow lights are dim or flicker.
- 8 Turn signals will not function.
- 9 Turn signals flash rapidly.
- 10 No running lights on Plow.

CURTIS SNO-PRO 3000 / HOME-PRO / TRIP-EDGE w/HYD. JACK TROUBLESHOOTING GUIDE

Section A. Plow Hydraulic System		
Symptom	Possible Cause	Remedy
1. Motor runs but no Plow function(s).	Solenoid Coils not receiving voltage	Test voltage to coils with meter or test light to verify that coils are receiving power. If coils are not receiving power, check ground connection and verify that all coils are connected properly.
	Inadequate Pump pressure	Remove lift hose from lift cylinder and attach 3000 psi pressure gauge to lift hose. Activate Plow lift function and read pressure gauge. Gauge should read 2000 psi. If not enough pressure or no pressure, remove relief valve and inspect for damaged spring or ball. If no damage is apparent, clean using mineral spirits and re-install. Perform pressure test again.
2. Motor runs but all functions are slow.	Inadequate Pump pressure	Perform test procedure described above.
	Inadequate Pump flow	Inspect filter cartridge in end head and pick-up screen in reservoir for clogging. Clean filter or replace.
	Insufficient voltage output from vehicle	Check alternator output wire with vehicle running at idle, with multimeter for 12-14vdc. If alternator output is less than 12vdc, repair or replace alternator.
3. Motor runs but Blade raises slowly or does not raise.	Inadequate Pump pressure	Perform pressure test as described in Section A. #1
	Lift solenoid valve contaminated	Remove A-Frame Cover and locate lift valve. Remove coil retaining nut from valve and slide the two coils off of the valve stem. Unscrew valve from manifold block and inspect for contamination. Clean valve with mineral spirits and blow dry with compressed air. Re-Install valve, coils, and nut. Check Plow function. If blade does not raise, go to next test.
	Loose or damaged lift hose	Inspect hose for leaks or signs of wear. Replace lift hose if necessary.

CURTIS SNO-PRO 3000 / HOME-PRO / TRIP-EDGE w/HYD. JACK TROUBLESHOOTING GUIDE

Section A. Plow Hydraulic System		
Symptom	Possible Cause	Remedy
3. Motor runs but Blade raises slowly or does not raise (continued).	Lower solenoid valve contaminated	Remove A-Frame cover and locate Lower valve. Remove coil retaining nut from valve and slide the coil off of the valve stem. Unscrew valve from manifold block and inspect for contamination. Clean valve with mineral spirits and blow dry with compressed air. Re-install valve, coil, and nut. Check plow function.
4. Blade will not lower.	Lower solenoid valve contaminated	Perform test procedure described in Section A, #3.
	Orifice plug blocked	Remove hose from port 'H' on the manifold. Use a thin wire to remove orifice from within the 'H' port. Blow out orifice with compressed air. Re-install in reverse order. Check plow function.
5. Blade lowers in neutral.	Lower solenoid valve contaminated	Perform test procedure described in Section A, #3.
6. Blade will not angle in one or both directions, lift and lower functions are ok.	Solenoid coils are not receiving voltage.	Check voltage to coils with 12v test light or multimeter. With plow attached to the truck, remove A-Frame cover and locate angle solenoid valve. Ground test light or meter to main plow ground wire. Unplug outer (left) solenoid coil plug and insert probe into harness end of coil plug (NOTE: the orange wire on all solenoid coils is a ground wire, 12v+ wire color varies). Activate plow angle function and check for voltage. If voltage is present, reattach coil plug to outer solenoid coil and insert probe into 12v+ coil wire. Activate plow angle function. If voltage is not present, replace solenoid coil. If voltage is present, repeat procedure for inner coil.
	Angle solenoid valve contaminated	With A-Frame Cover removed, locate angle solenoid valve. It may be necessary to remove the pump unit from the A-Frame cavity for this step. Once pump is removed, remove coil retaining nut and slide the two coils off of the valve stem.

CURTIS SNO-PRO 3000 / HOME-PRO / TRIP-EDGE w/HYD. JACK TROUBLESHOOTING GUIDE

Section A. Plow Hydraulic System		
Symptom	Possible Cause	Remedy
7. Blade will not remain angled.	Cross port relief valve(s) contaminated or damaged.	Use an allen key to remove the cross port relief plugs. Remove ball and spring from within cavity and inspect for any damage or wear, replace if necessary. Inspect bottom of cavity surface and remove any contamination, clean with mineral spirits and re-assemble.
8. Motor runs but Jack Leg will not extend.	Jack extend coil is not receiving sufficient voltage.	Remove A-Frame cover. Locate jack extend solenoid coil. Perform procedure described in Section A, #6 on jack extend coil, replace solenoid coil if necessary.
	Jack retract solenoid valve contaminated	With A-Frame cover removed, locate jack extend solenoid valve (pp. 12,16 for detail) Remove coil retaining nut and slide two solenoid coils off of valve stem. Unscrew valve from manifold. Clean valve with mineral spirits and blow dry with compressed air. Re-install valve and coils in reverse order and check jack function.
	Orifice plug contaminated	Remove A-Frame cover. It is necessary to remove the pump from the A-Frame cavity for this step. Remove the hose and adapter from 'X' port on manifold. Use a 3mm allen key and remove the orifice plug located at the bottom of the 'X' port. Clean orifice with mineral spirits and blow dry with compressed air. Re-install in reverse order and check jack function.
9. No jack functions, motor does not run.	Poor harness connection at front of vehicle.	Check harness plug connection at plug mount and verify good contact. Plug must be coated with di-electric grease periodically to prolong the life of the pin connectors.
	In-cab controls not in the float position.	Select 'float' position on in-cab controls and re-try jack function.
10. Jack does not retract.	Low or no voltage to 'Jack Retract' solenoid coil.	Check for voltage at retract coil with 12v test light or multimeter using procedure described in Section A, #6. If voltage is present, see next step.

CURTIS SNO-PRO 3000 / HOME-PRO / TRIP-EDGE w/HYD. JACK TROUBLESHOOTING GUIDE

Section A. Plow Hydraulic System		
Symptom	Possible Cause	Remedy
10. Jack does not retract (continued).	Low or no voltage to 'Lift' solenoid coil.	Check for voltage at lift coil with 12v test light or multimeter using procedure described in Section A, #6. If voltage is present, see next step.
	Jack Retract solenoid valve contaminated.	Remove A-Frame cover. Locate 'Jack Retract' solenoid coil (pp. 12,16 for detail). Remove coil retaining nut, solenoid coil, and valve from manifold. Clean valve with mineral spirits and blow dry with compressed air. Re-install and check function.
	Jack Retract Return Spring does not have enough tension.	Remove bottom A-Frame cover and locate 'Jack Return Spring'. Locate adjuster nut on spring guide rod. Tighten adjuster nut against return spring to increase tension. Do this step in 1/4" increments and check function.
	Orifice plug contaminated	Remove A-Frame cover. It is necessary to remove the pump from the A-Frame cavity for this step. Remove the hose and adapter from 'X' port on manifold. Use a 3mm allen key and remove the orifice plug located at the bottom of the 'X' port. Clean orifice with mineral spirits and blow dry with compressed air. Re-install in reverse order and check jack function.
Section B. Plow Electrical System		
Symptom	Possible Cause	Remedy
1. Pump motor will not run.	Check that Main Power Connector is connected properly.	Plug in Connector.

CURTIS SNO-PRO 3000 / HOME-PRO / TRIP-EDGE w/HYD. JACK TROUBLESHOOTING GUIDE

Section B. Plow Electrical System		
Symptom	Possible Cause	Remedy
1. Pump motor will not run (continued).	Check for voltage at Main Power Connector pins 1 and 2 with ignition switch ON and LIFT, RIGHT or LEFT function is activated.	If voltage is present, remove pump cover and check for voltage at pump with ignition switch on and LIFT, RIGHT or LEFT function is activated, if voltage is present, pump has failed or pump has seized. If voltage is not present go to next test.
	Check for voltage at solenoid by testing for voltage at both large terminals and ground.	If voltage is not present between one large terminal and ground, check the cable from the solenoid to the battery for disconnected cable or broken cable. If voltage is present go to next test.
	Check for voltage at other large terminal on solenoid by testing for voltage between terminal and ground while applying power to the small terminal with the Brown wire.	If no voltage is present, solenoid has failed. If solenoid is not grounded, ground solenoid bracket and retest. If voltage is present go to next test.
	Check that Black wire for voltage at the White 9-pin connector in cab with the ignition switch on.	If no voltage is present, power is disconnected from fuse box or fuse has been tripped. If voltage is present go to next test.
	Check wiring in control. Check for voltage to control switches with ignition switch on and control switch ON test all Black wires for voltage.	If voltage is not present on all black wire terminals and ground, check for disconnected wires or broken wires. If voltage is present go to next test.

CURTIS SNO-PRO 3000 / HOME-PRO / TRIP-EDGE w/HYD. JACK TROUBLESHOOTING GUIDE

Section B. Plow Electrical System		
Symptom	Possible Cause	Remedy
1. Pump motor will not run (continued).	Check for voltage to Brown wire at control switches with ignition switch ON and a LIFT, RIGHT or LEFT function is activated.	If voltage is not present on Brown wire terminal and ground with a function activated. Check for disconnected wires or broken wires, or failed switch.
2. Pump motor runs continually.	Disconnect switch control or joystick control at the white 9-pin connector in cab.	If pump continues to run, pump solenoid has failed in a locked on position. Remove power to pump by disconnecting Main Power connector. Replace solenoid.
		If pump stops running, check control for stuck switches or a short between black and brown wires.
3. Plow will not raise.	Check that Main Power Connector is connected properly.	Plug in Connector.
	With ignition switch on and Lift function activated check for voltage between the Red and Orange ground wire on valve body connector.	If voltage is present, valve coil or solenoid valve has failed or Battery is weak or defective. If voltage is not present go on to next test.
	With ignition switch on and Lift function activated check for voltage between terminal 4 and terminal 1 (ground) on vehicle Main Power Connector.	If no voltage is present, check for broken wires or broken or corroded terminals on vehicle harness. If voltage is present, check for broken or corroded wires or terminals on the Plow harness.
4. Plow will not lower.	Check that Main Power Connector is connected properly.	Plug in Connector.

CURTIS SNO-PRO 3000 / HOME-PRO / TRIP-EDGE w/HYD. JACK TROUBLESHOOTING GUIDE

Section B. Plow Electrical System		
Symptom	Possible Cause	Remedy
4. Plow will not lower (continued).	With ignition switch On and Float function activated check for voltage between the Green and Orange ground wire on valve body power connector.	If voltage is present, valve coil or solenoid valve has failed or Battery is weak or defective. If voltage is not present go to next test.
	With ignition switch On and Lift function activated check for voltage between terminal 3 and terminal 1 (ground) on vehicle Main Power Connector.	If no voltage is present, check for broken wires or broken or corroded terminals on vehicle harness. If voltage is present, check for broken or corroded wires or terminals on the Plow harness.
5. Plow will not Angle Right.	Check that Main Power Connector is connected properly.	Plug in Connector.
	With ignition switch On and Right function activated check for voltage between the White and Orange ground wire on valve body power connector.	If voltage is present, valve coil or solenoid valve has failed or Battery is weak or defective. If voltage is not present go to next test.
	With ignition switch On and Lift function activated check for voltage between terminal 6 and terminal 1 (ground) on vehicle Main Power Connector.	If no voltage is present, check for broken wires or broken or corroded terminals on vehicle harness. If voltage is present, check for broken or corroded wires or terminals on the Plow harness.
6. Plow will not Angle Left.	Check that Main Power Connector is connected properly.	Plug in Connector.

CURTIS SNO-PRO 3000 / HOME-PRO / TRIP-EDGE w/HYD. JACK TROUBLESHOOTING GUIDE

Section B. Plow Electrical System		
Symptom	Possible Cause	Remedy
6. Plow will not angle Left (continued).	With ignition switch ON and Left function activated check for voltage between Blue and Orange ground wire on valve body power connector.	If voltage is present, valve coil or solenoid valve has failed or Battery is weak or defective. If voltage is not present go to next test.
	With ignition switch On and Lift function activated check for voltage between terminal 5 and terminal 1 (ground) on vehicle Main Power Connector.	If no voltage is present, check for broken wires or broken or corroded terminals on vehicle harness. If voltage is present, check for broken or corroded wires or terminals on the Plow harness.
7. Left & Right functions reversed.	Verify the correct wire placement of the White and Blue wires by referring to the Curtis SNO-PRO 3000 Harness Layout.	Plug connectors in the correct location.
	With the switch panel verify the correct wire placement at the switch.	Switch the Blue and White wires at the back of the switch panel.
8. Raise & Lower functions reversed.	Verify the correct wire placement of the Red and Green wires by referring to the Curtis SNO-PRO 3000 Harness Layout.	Plug connectors in the correct location.
	With the switch panel verify the correct wire placement at the switch.	Switch the Red and Green wires at the back of the switch panel.

CURTIS SNO-PRO 3000 / HOME-PRO / TRIP-EDGE w/HYD. JACK TROUBLESHOOTING GUIDE

Section B. Plow Electrical System		
Symptom	Possible Cause	Remedy
9. Plow will not remain in Float.	Check Raise and Lower Switch for worn out Detent position by testing for maintained voltage between the Green and Orange ground wires.	Replace Switch.
	Check Joystick control for worn out Detent position or bent switch actuator by testing for maintained voltage between the Green and Orange ground wires.	Bend Switch actuator to compensate for worn out detent. Replace detent assembly or Joystick Control.
	Verify a good ground to Joystick Control.	Ground Orange Wire.
10. Plow Jack will not Extend.	With ignition switch On and Float function activated check Green wire on Jack Switch for voltage.	If voltage is present go to next test. If voltage is not present, check for voltage between the Green and Orange ground wire on valve body power connector. Verify that control is in Float, check for broken wires.
	With ignition switch On and Control in Float, push the Jack switch down (Jack extend) and verify that Pump motor runs.	If pump motor runs go to next test. Check for voltage on Brown wire terminal and ground with a function activated. Check for correct wire placement at the switch, disconnected wires or broken wires or failed switch.
	With ignition switch On and Control in Float, push the Jack switch down (Jack extend) and check for voltage between the Light Blue/Black and Orange ground wire on valve body power connector.	If voltage is present , valve coil or solenoid has failed or Battery is weak or defective. If voltage is not present, check for correct wire placement at the switch, disconnected wires or failed switch.

CURTIS SNO-PRO 3000 / HOME-PRO / TRIP-EDGE w/HYD. JACK TROUBLESHOOTING GUIDE

Section B. Plow Electrical System		
Symptom	Possible Cause	Remedy
11. Plow Jack will not Retract.	With ignition switch On and Float function activated check Green wire on Jack Switch for voltage.	If voltage is present go to next test. If voltage is not present, check for voltage between the Green and Orange ground wire on valve body power connector. Verify that control is in Float check for broken wires.
	With ignition switch On and Control in Float, lift the Jack switch Up (Jack retract) and check for voltage between the Pink/Black and Orange ground wire on valve body power connector.	If voltage is present , valve coil or solenoid has failed or Battery is weak or defective. If voltage is not present, check for correct wire placement at the switch, disconnected wires or failed switch.
12. Plow Jack will not Retract when Plow is raised.	With ignition switch On and Lift function activated check for voltage between the Pink/ Black and Orange ground wire on valve body power connector.	If voltage is present , valve coil or solenoid has failed or Battery is weak or defective. If voltage is not present, check for broken wires or failed Jack Retract Diode.
13. Plow raises when Jack retracting.	With ignition switch On and Control in Float, lift the Jack switch Up (Jack retract) and check for voltage between the Pink/Black and Orange ground wire on valve body power connector.	If voltage is present , Jack Retract Diode has failed. Replace Diode.

CURTIS SNO-PRO 3000 / HOME-PRO / TRIP-EDGE w/HYD. JACK TROUBLESHOOTING GUIDE

Section B. Plow Electrical System

Symptom	Possible Cause	Remedy
14. Battery goes dead when vehicle is OFF.	Disconnect switch control or joystick control at the White 9-pin connector in cab with ignition switch Off check for voltage between the Black and Orange ground.	If voltage is present, move black wire to a switched circuit that turns off with the vehicles ignition.
15. Battery goes dead when vehicle is running.	Test condition of Vehicles battery.	Charge battery and retest or replace battery.
	Test condition of vehicles charging system.	Repair charging system.
	Check for electrical shorts.	Repair electrical shorts in electrical system.

Section C. Plow Lighting Electrical System

Symptom	Possible Cause	Remedy
1. No lights on vehicle or Plow.	Check electrical connections.	Verify connections at toggle switch, headlight adapters and Plow headlight connectors. Refer to Curtis Harness layout sheet.
	Check headlight adapters.	Insure that proper headlight adapters are being used.
Note: Some new vehicles use a (floating ground) or (hot ground) system. Check with vehicle manufacturer for test procedure.	(Ground test) with Headlight switch On check for voltage to Light Green and ground for Low beam and Yellow and ground for High beam.	If voltage is not present, check for disconnected wires or broken wires. Repair or replace as necessary.

CURTIS SNO-PRO 3000 / HOME-PRO / TRIP-EDGE w/HYD. JACK TROUBLESHOOTING GUIDE

Section C. Plow Lighting Electrical System

Symptom	Possible Cause	Remedy
1. No lights on vehicle or Plow (continued).	(Floating ground or Hot ground) With headlight switch On check for voltage to Light Green and (12 Volt +) for Low beam and Yellow and (12 Volt +) for High beam.	If voltage is not present, check for disconnected wires or broken wires.
2. Plow lights will not come On.	Check electrical connections.	Verify connections at toggle switch and Plow headlight connectors. Refer to Curtis Harness layout sheet.
	With Headlight Switch On and Headlight toggle switch set to Plow check for voltage between terminals 8 and 9 for Low beam and terminals 8 and 10 for High beam on Vehicle Main power connector.	
3. Plow lights function but Vehicle lights will not come On.	Incorrect Headlight Adapter Kit	Verify headlight adapter kit number and wiring connections. Verify light switch is wired correctly.
4. High and Low beam reversed on Plow.	Check electrical connections on toggle switch.	Verify connections at toggle switch, headlight adapters and Plow headlight connectors. Refer to Curtis Harness layout sheet.
	Check headlight adapters	Insure that proper headlight adapters are being used.
5. High beam indicator not functioning properly.	Check electrical connections on toggle switch.	Verify connections at toggle switch, headlight adapters and Plow headlight connectors. Refer to Curtis Harness layout sheet.
	Check electrical connections at headlight and headlight adapters.	Verify connections at headlight adapters and Plow headlight connectors. Refer to Curtis Harness layout sheet.

CURTIS SNO-PRO 3000 / HOME-PRO / TRIP-EDGE w/HYD. JACK TROUBLESHOOTING GUIDE

Section C. Plow Lighting Electrical System

Symptom	Possible Cause	Remedy
6. Headlight fuse blows after installing new Plow Lights.	Remove Plow headlight bulb and check that there is NO wire from 3 prong head light connector to ground.	Replace with original Curtis Snow Plow lights.
7. Plow parking & directional lights are dim and/or flicker.	Check Plow lights for good ground.	Remove paint under headlight mounts and retighten mounting bolts.
	Check electrical connections for corroded or damaged terminals.	Repair or replace damaged terminals.
8. Turn signals will not function.	Check electrical connections to vehicle wiring. See Harness Layout for proper connections.	Repair any damaged connections.
9. Turn signals flash rapidly.	Check for burned out bulb filaments.	Replace bulbs.
	Check Flasher	Replace original vehicle flasher with heavy-duty flasher.
10. No running lights on Plow.	Check electrical connections to vehicle wiring. See Harness Layout for proper connections.	Repair any damaged connections.

CURTIS SNOWPLOWS

Curtis International, Inc. 111 Higgins Street Worcester, Ma. 01606
Phone: 508-853-2200 Fax: 508-854-3377

Warranty Claim Processing

Eligibility Requirements To Qualify For Warranty Consideration

1. Repair condition occurred within 12 months of the original purchase date.
2. A copy of the original sales receipt is submitted to Curtis with the Warranty Claim form.
3. The Owner Registration Form is on file at Curtis.
4. The Vehicle Condition Inspection & Snowplow Installation/Delivery Checklist was completed and is on file at Curtis.
5. Repair must be completed by an authorized Curtis dealer within 30 days of failure.

Completing The Warranty Repairs and The Warranty Claim Form

1. Complete Customer/Equipment Information Section 1.
2. Diagnose problem, determine corrective action to be taken and complete Section 2.
3. Complete Section 3 detailing parts to be submitted for warranty consideration.
Parts required to complete the repair must come from dealer inventory.
If you need parts to complete the repair, order them within the normal ordering process.
Parts will be shipped and charged to your account with a credit issued when the claim is approved.
4. Complete Section 4 detailing labor to be submitted for warranty consideration.
For repair codes, see reverse side for Flat Rate Schedule and allowances.
If repairs are not listed in the Flat Rate Schedule, contact Curtis Warranty Department at 1-800-343-7676 for approval prior to making repairs.
5. Parts replaced for the repair must be kept at the dealer/distributor location for a period of 90 days, identified by the equipment serial number and Warranty Claim Form number.
Curtis may, within a 90 day period, request any and all parts be returned for examination before approval of the warranty claim.
Parts returned should be returned transportation prepaid.
Do not return parts unless requested to do so by Curtis.

Submitting Warranty Claim For Consideration

Once the repairs have been completed, review the Claim Form for accuracy and completeness and submit the top two copies (white & canary) to Curtis Warranty Department at the address listed on the claim form with a copy of the original sales receipt. Retain the pink copy of the Claim Form for your records. **Missing or inaccurate information will delay the processing and crediting of your account for parts and labor.**