



**DiamondMax 21**  
**200 - 320GB**  
**ATA**

November 2006

PN: 100435213

© 2006, Maxtor Corporation All rights reserved  
Publication number: 100435213, Rev. A  
November 2006

Maxtor and MaxFax are registered trademarks of Maxtor Corporation, registered in the U.S.A. and other countries. Maxtor DiamondMax, AutoTransfer, AutoRead, AutoWrite, Dis-Cache, DiskWare, Defect Free Interface, QuickView, and WriteCache are trademarks of Maxtor Corporation. All other brand names or trademarks are the property of their manufacturers.

Maxtor reserves the right to change, without notice, product offerings or specifications. No part of this publication may be reproduced in any form without written permission of Maxtor Corporation.





# Contents

<b>1.0</b>	<b>Introduction</b>	<b>1</b>
<b>2.0</b>	<b>Drive specifications</b>	<b>3</b>
2.1	Specification summary tables	3
2.2	Formatted capacity	12
2.2.1	LBA mode	12
2.3	Default logical geometry	12
2.4	Recording and interface technology	13
2.5	Physical characteristics	13
2.6	Seek time	14
2.7	Start/stop times	14
2.8	Power specifications	14
2.8.1	Power consumption	14
2.8.2	Conducted noise	16
2.8.3	Voltage tolerance	17
2.8.4	Power-management modes	17
2.9	Environmental specifications	18
2.9.1	Ambient temperature	18
2.9.2	Temperature gradient	18
2.9.3	Humidity	18
2.9.4	Altitude	18
2.9.5	Shock	19
2.9.6	Vibration	19
2.10	Acoustics	20
2.11	Electromagnetic immunity	21
2.12	Reliability	22
2.12.1	Annualized Failure Rate (AFR and Mean Time Between Failures (MTBF)	22
2.13	Agency certification	22
2.13.1	Safety certification	22
2.13.2	Electromagnetic compatibility	22
2.13.3	FCC verification	23
2.14	Environmental protection	23
2.14.1	European Union Restriction of Hazardous Substances (RoHS)	24
2.15	Corrosive environment	24
<b>3.0</b>	<b>Configuring and mounting the drive</b>	<b>25</b>
3.1	Handling and static discharge precautions	25
3.2	Breather filter hole precautions	26
3.3	Jumper settings	27
3.3.1	Master/slave configuration	27
3.3.2	Cable-select option	27
3.3.3	Ultra ATA/100 cable	28
3.4	Drive mounting	28
<b>4.0</b>	<b>ATA interface</b>	<b>31</b>
4.1	ATA interface signals and connector pins	31
4.1.1	Supported ATA commands	32
4.1.2	Identify Device command	34
4.1.3	Set Features command	37
4.1.4	S.M.A.R.T. commands	38
<b>5.0</b>	<b>Maxtor support services</b>	<b>39</b>



## List of Figures

Figure 1.	Typical 5V startup and operation current profile . . . . .	16
Figure 2.	Typical 12V startup and operation current profile . . . . .	16
Figure 3.	Breather filter hole location . . . . .	26
Figure 4.	Master/slave jumper settings . . . . .	27
Figure 5.	Ultra ATA cable connectors . . . . .	28
Figure 6.	Mounting dimensions . . . . .	29
Figure 7.	I/O pins and supported ATA signals . . . . .	31





## 1.0 Introduction

---

This manual describes the functional, mechanical and interface specifications for the following Maxtor® DiamondMax® 21 PATA model drives:

STM3320820A	STM3250820A	STM3200820A
STM3300620A	STM3250620A	

These drives provide the following key features:

- 7,200-RPM spindle speed
- High instantaneous (burst) data transfer rates (up to 100 Mbytes per second) using Ultra DMA mode 5.
- Tunneling Giant magnetoresistive (TGMR) recording heads and EPRML technology, which provide the drives with increased areal density.
- State-of-the-art cache and on-the-fly error-correction algorithms.
- Full-track multiple-sector transfer capability without local processor intervention.
- Quiet operation.
- SeaTools diagnostic software performs a drive self-test that eliminates unnecessary drive returns.
- Support for S.M.A.R.T. drive monitoring and reporting.
- Support for Read Multiple and Write Multiple commands.
- Support for autodetection of master/slave drives that use cable select (CSEL).



## 2.0 Drive specifications

---

Unless otherwise noted, all specifications are measured under ambient conditions, at 25°C, and nominal power. For convenience, the phrases *the drive* and *this drive* are used throughout this manual to indicate the following drive models:

STM3320820A	STM3250820A	STM3200820A
STM3300620A	STM3250620A	

### 2.1 Specification summary tables

The specifications listed in the following tables are for quick reference. For details on specification measurement or definition, see the appropriate section of this manual.

**Table 1: Drive specifications summary for the 320 Gbyte model**

Drive specification	STM3320820A
Formatted Gbytes (512 bytes/sector)*	320
Guaranteed sectors	625,142,448
Heads	4
Discs	2
Bytes per sector	512
Default sectors per track	63
Default read/write heads	16
Default cylinders	16,383
Recording density	781 kbits/in max
Track density	145 ktrakcs/in avg.
Areal density	114.4 Gbits/in <sup>2</sup> avg
Spindle speed	7,200 RPM
Internal data transfer rate	1,030 Mbits/sec max
Sustained data transfer rate	72 Mbytes/sec max
I/O data-transfer rate	100 Mbytes/sec max
ATA data-transfer modes supported	PIO modes 0–4 Multiword DMA modes 0–2 Ultra DMA modes 0–5
Cache buffer	8 Mbytes
Height (max)	26.1 mm (1.028 inches)
Width (max)	101.6 mm (4.000 inches) +/- 0.010 inches
Length (max)	146.99 mm (5.787 inches)
Weight	580 grams
Average latency	4.16 msec
Power-on to ready (max)	15 sec
Standby to ready (max)	15 sec
Track-to-track seek time (typical)	<0.8 msec (read), <1.0 msec (write)
Average seek, read (typical)	<11.0 msec
Average seek, write (typical)	<12.0 msec
Startup current (typical) 12V (peak)	2.8 amps
Voltage tolerance (including noise)	5V ± 5% 12V ± 10%
Ambient temperature	0° to 60°C (operating) –40° to 70°C (nonoperating)
Temperature gradient	20°C per hour max (operating) 30°C per hour max (nonoperating)
Relative humidity	5% to 90% (operating) 5% to 95% (nonoperating)
Relative humidity gradient	30% per hour max
Wet bulb temperature (max)	37.7°C (operating) 37.7°C (nonoperating)
Altitude, operating	–60.96 m to 3,048 m (–200 ft. to 10,000+ ft.)
Altitude, nonoperating (below mean sea level, max)	–60.96 m to 12,192 m (–200 ft. to 40,000+ ft.)
Operational Shock	68 G at 2 msec
Non-Operational Shock	350 G at 2 msec

<b>Drive specification</b>	<b>STM3320820A</b>
Vibration, operating	5–22 Hz: 0.25 G, Limited displacement 22–350 Hz: 0.50 G 350–500 Hz:: 0.25 G
Vibration, nonoperating	5–22 Hz: 0.25 G, Limited displacement 22–350 Hz: 5.0 G 350–500 Hz:: 1.0 G
Drive acoustics, sound power (Bels)	
Idle**	2.7 (typical) 3.0 (max)
Quiet seek	3.0 (typical) 3.4 (max)
Nonrecoverable read errors	1 per 10 <sup>14</sup> bits read
Annualized Failure Rate (AFR)	0.34%
Warranty	3 years on distribution units. To determine the warranty for a specific drive, use a web browser to access the following web page: <a href="http://www.seagate.com/support/service/">www.seagate.com/support/service/</a> From this page, click on the "Verify Your Warranty" link. You will be asked to provide the drive serial number, model number (or part number) and country of purchase. The system will display the warranty information for your drive.
Contact start-stop cycles	50,000 at 25°C, 50% rel. humidity

**Table 2: Drive specifications summary for the 300 Gbyte model**

Drive specification	STM3300620A
Formatted Gbytes (512 bytes/sector)*	300
Guaranteed sectors	586,072,368
Heads	4
Discs	2
Bytes per sector	512
Default sectors per track	63
Default read/write heads	16
Default cylinders	16,383
Recording density	781 kbits/in max
Track density	145 ktracks/in avg.
Areal density	114.4 Gbits/in <sup>2</sup> avg
Spindle speed	7,200 RPM
Internal data transfer rate	1,030 Mbits/sec max)
Sustained data transfer rate OD	72 Mbytes/sec max
I/O data-transfer rate	100 Mbytes/sec max
ATA data-transfer modes supported	PIO modes 0–4 Multiword DMA modes 0–2 Ultra DMA modes 0–5
Cache buffer	16 Mbytes
Height (max)	26.1 mm (1.028 inches)
Width (max)	101.6 mm (4.000 inches) +/- 0.010 inches
Length (max)	146.99 mm (5.787 inches)
Weight (max)	580 grams
Average latency	4.16 msec
Power-on to ready (max)	11 sec
Standby to ready (max)	15 sec
Track-to-track seek time (typical)	<0.8 msec (read), <1.0 msec (write)
Average seek, read (typical)	<11.0 msec
Average seek, write (typical)	<12.0 msec
Startup current (typical) 12V (peak)	2.8 amps
Voltage tolerance (including noise)	5V ± 5% 12V ± 10%
Ambient temperature	0° to 60°C (operating) –40° to 70°C (nonoperating)
Temperature gradient	20°C per hour max(operating) 30°C per hour max (nonoperating)
Relative humidity	5% to 90% (operating) 5% to 95% (nonoperating)
Relative humidity gradient	30% per hour max
Wet bulb temperature	37.7°C max (operating) 37.7°C max (nonoperating)
Altitude, operating	–60.96 m to 3,048 m (–200 ft. to 10,000+ ft.)
Altitude, nonoperating (below mean sea level, max)	–60.96 m to 12,192 m (–200 ft. to 40,000+ ft.)
Operational Shock	68 G at 2 msec
Non-Operational Shock	350 G at 2 msec

<b>Drive specification</b>	<b>STM3300620A</b>
Vibration, operating	5–22 Hz: 0.25 G, Limited displacement 22–350 Hz: 0.50 G 350–500 Hz:: 0.25 G
Vibration, nonoperating	5–22 Hz: 0.25 G, Limited displacement 22–350 Hz: 5.0 G 350–500 Hz:: 1.0 G
Drive acoustics, sound power (Bels)	
Idle**	2.5 (typical) 2.8 (max)
Quiet seek	3.0 (typical) 3.1 (max)
Nonrecoverable read errors	1 per 10 <sup>14</sup> bits read
Annualized Failure Rate (AFR)	0.34%
Warranty	3 years on distribution units. To determine the warranty for a specific drive, use a web browser to access the following web page: <a href="http://www.seagate.com/support/service/">www.seagate.com/support/service/</a> From this page, click on the "Verify Your Warranty" link. You will be asked to provide the drive serial number, model number (or part number) and country of purchase. The system will display the warranty information for your drive.
Contact start-stop cycles	50,000 at 25°C, 50% rel. humidity

**Table 3: Drive specifications summary for 250 Gbyte models**

Drive specification	STM3250820A	STM3250620A
Formatted Gbytes (512 bytes/sector)*	250	
Guaranteed sectors	488,397,168	
Heads	3	
Discs	2	
Bytes per sector	512	
Default sectors per track	63	
Default read/write heads	16	
Default cylinders	16,383	
Recording density	813 kbits/in max	
Track density	145 ktracks/in avg.	
Areal density	114.4 Gbits/in <sup>2</sup> avg	
Spindle speed	7,200 RPM	
Internal data transfer rate	1,030 Mbits/sec max	
Sustained data transfer rate OD	72 Mbytes/sec max	
I/O data-transfer rate	100 Mbytes/sec max	
ATA data-transfer modes supported	PIO modes 0–4 Multiword DMA modes 0–2 Ultra DMA modes 0–5	
Cache buffer	8 Mbytes	16 Mbytes
Height (max)	26.1 mm (1.028 inches)	
Width (max)	101.6 mm (4.000 inches) +/- 0.010 inches	
Length (max)	146.99 mm (5.787 inches)	
Weight (max)	580 grams	
Average latency	4.16 msec	
Power-on to ready (max)	11 sec	
Standby to ready (max)	15 sec	
Track-to-track seek time (typical)	<0.8 msec (read), <1.0 msec (write)	
Average seek, read (typical)	<11.0 msec	
Average seek, write (typical)	<12.0 msec	
Startup current (typical) 12V (peak)	2.8 amps	
Voltage tolerance (including noise)	5V ± 5% 12V ± 10%	
Ambient temperature	0° to 60°C (operating) –40° to 70°C (nonoperating)	
Temperature gradient	20°C per hour max (operating) 30°C per hour max (nonoperating)	
Relative humidity	5% to 90% (operating) 5% to 95% (nonoperating)	
Relative humidity gradient	30% per hour max	
Wet bulb temperature	37.7°C max (operating) 37.7°C max (nonoperating)	
Altitude, operating	–60.96 m to 3,048 m (–200 ft. to 10,000+ ft.)	
Altitude, nonoperating (below mean sea level, max)	–60.96 m to 12,192 m (–200 ft. to 40,000+ ft.)	
Operational Shock	68 G at 2 msec	
Non-Operational Shock	350 G at 2 msec	



Drive specification	STM3250820A	STM3250620A
Vibration, operating	5–22 Hz: 0.25 G, Limited displacement 22–350 Hz: 0.50 G 350–500 Hz:: 0.25 G	
Vibration, nonoperating	5–22 Hz: 0.25 G, Limited displacement 22–350 Hz: 5.0 G 350–500 Hz:: 1.0 G	
Drive acoustics, sound power (Bels)		
Idle**	2.5 (typical) 2.8 (max)	
Quiet seek	3.0 (typical) 3.1 (max)	
Nonrecoverable read errors	1 per 10 <sup>14</sup> bits read	
Annualized Failure Rate (AFR)	0.34%	
Warranty	3 years on distribution units. To determine the warranty for a specific drive, use a web browser to access the following web page: <a href="http://www.seagate.com/support/service/">www.seagate.com/support/service/</a> From this page, click on the “Verify Your Warranty” link. You will be asked to provide the drive serial number, model number (or part number) and country of purchase. The system will display the warranty information for your drive.	
Contact start-stop cycles (25°C, 50% rel. humidity)	50,000	

**Table 4: Drive specifications summary for the 200 Gbyte model**

Drive specification	STM3200820A
Formatted Gbytes (512 bytes/sector)*	200
Guaranteed sectors	390,721,968
Heads	3
Discs	2
Bytes per sector	512
Default sectors per track	63
Default read/write heads	16
Default cylinders	16,383
Recording density	781 kbits/in max
Track density	145 ktracks/in avg.
Areal density	114.4 Gbits/in <sup>2</sup> avg
Spindle speed	7,200 RPM
Internal data transfer rate	1,030 Mbits/sec max
Sustained data transfer rate OD	72 Mbytes/sec max
I/O data-transfer rate	100 Mbytes/sec max
ATA data-transfer modes supported	PIO modes 0–4 Multiword DMA modes 0–2 Ultra DMA modes 0–5
Cache buffer	8 Mbytes
Height (max)	26.1 mm (1.028 inches)
Width (max)	101.6 mm (4.000 inches) +/- 0.010 inches
Length (max)	146.99 mm (5.787 inches)
Weight (max)	580 grams
Average latency	4.16 msec
Power-on to ready (max)	11 sec
Standby to ready (max)	15 sec
Track-to-track seek time (typical)	<0.8 msec (read), <1.0 msec (write)
Average seek, read (typical)	<11.0 msec
Average seek, write (typical)	<12.0 msec
Startup current (typical) 12V (peak)	2.8 amps
Voltage tolerance (including noise)	5V ± 5% 12V ± 10%
Ambient temperature	0° to 60°C (operating) –40° to 70°C (nonoperating)
Temperature gradient	20°C per hour max (operating) 30°C per hour max (nonoperating)
Relative humidity	5% to 90% (operating) 5% to 95% (nonoperating)
Relative humidity gradient	30% per hour max
Wet bulb temperature	37.7°C max) (operating) 37.7°C max) (nonoperating)
Altitude, operating	–60.96 m to 3,048 m (–200 ft. to 10,000+ ft.)
Altitude, nonoperating (below mean sea level, max)	–60.96 m to 12,192 m (–200 ft. to 40,000+ ft.)
Operational Shock	68 G max at 2 msec
Non-Operational Shock	350 G max at 2 msec

<b>Drive specification</b>	<b>STM3200820A</b>
Vibration, operating	5–22 Hz: 0.25 G, Limited displacement 22–350 Hz: 0.50 G 350–500 Hz:: 0.25 G
Vibration, nonoperating	5–22 Hz: 0.25 G, Limited displacement 22–350 Hz: 5.0 G 350–500 Hz:: 1.0 G
Drive acoustics, sound power (Bels)	
Idle**	2.5 (typical) 2.8 (max)
Quiet seek	3.0 (typical) 3.1 (max)
Nonrecoverable read errors	1 per 10 <sup>14</sup> bits read
Annualized Failure Rate (AFR)	0.34%
Warranty	3 years on distribution units. To determine the warranty for a specific drive, use a web browser to access the following web page: <a href="http://www.seagate.com/support/service/">www.seagate.com/support/service/</a> From this page, click on the “Verify Your Warranty” link. You will be asked to provide the drive serial number, model number (or part number) and country of purchase. The system will display the warranty information for your drive.
Contact start-stop cycles (25°C, 50% rel. humidity)	50,000

\*One Gbyte equals one billion bytes when referring to hard drive capacity. Accessible capacity may vary depending on operating environment and formatting.

\*\*During periods of drive idle, some offline activity may occur according to the S.M.A.R.T. specification, which may increase acoustic and power to operational levels.

## 2.2 Formatted capacity

Model	Formatted capacity*	Guaranteed sectors	Bytes per sector
STM3320820A	320 Gbytes	625,142,448	512
STM3300620A	300 Gbytes	586,072,368	512
STM3250820A	250 Gbytes	488,397,168	512
STM3250620A	250 Gbytes	488,397,168	512
ST3200820A	200 Gbytes	390,721,968	512

\*One Gbyte equals one billion bytes when referring to hard drive capacity. Accessible capacity may vary depending on operating environment and formatting.

### 2.2.1 LBA mode

When addressing these drives in LBA mode, all blocks (sectors) are consecutively numbered from 0 to  $n-1$ , where  $n$  is the number of guaranteed sectors as defined above.

See Section 4.1.2, "Identify Device command" (words 60-61 and 100-103) for additional information about 48-bit addressing support of drives with capacities over 137 Gbytes.

## 2.3 Default logical geometry

Cylinders	Read/write heads	Sectors per track
16,383	16	63

## 2.4 Recording and interface technology

	320GB	300GB	250GB	200GB
Interface	ATA			
Recording method	Perpendicular			
Recording density, KBPI (kbits/inch max)	781		813	781
Track density, KTPI (ktracks/inch avg)	145			
Areal density (Gbits/inch <sup>2</sup> avg)	114.4			
Spindle speed (RPM) ( $\pm$ 0.2%)	7,200			
Internal data transfer rate (Mbits/sec max)	1,030			
Sustained data transfer rate (Mbytes/sec max)	72			
I/O data-transfer rate (Mbytes/sec max)	100 (Ultra DMA mode 5)			

## 2.5 Physical characteristics

Drive specification		
Maximum height	(mm)	26.1
	(inches)	1.028
Maximum width	(mm)	101.6
	(inches)	4.000 +/- 0.010
Maximum length	(mm)	146.99
	(inches)	5.787
Typical weight	STM3320820A	635 grams (1.4 lbs)
	STM3300620A	635 grams (1.4 lbs)
	STM3250620A	600 grams (1.32 lbs)
	STM3250820A	600 grams (1.32 lbs)
	STM3200820A	600 grams (1.32 lbs)
Cache Size	STM3320820A	8 Mbytes
	STM3300620A	16 Mbytes
	STM3250620A	16 Mbytes
	STM3250820A	8 Mbytes
	STM3200820A	8 Mbytes

## 2.6 Seek time

Seek measurements are taken with nominal power at 25°C ambient temperature. All times are measured using drive diagnostics. The specifications in the table below are defined as follows:

- Track-to-track seek time is an average of all possible single-track seeks in both directions.
- Average seek time is a true statistical random average of at least 5,000 measurements of seeks between random tracks, less overhead.

*Typical seek times (msec)	Read	Write
Track-to-track	<0.8	<1.0
Average	<11.0	<12.0
Average latency:	4.16	4.16

\*Measured in quiet mode

**Note.** These drives are designed to consistently meet the seek times represented in this manual. Physical seeks, regardless of mode (such as track-to-track and average), are expected to meet or exceed the noted values. However, due to the manner in which these drives are formatted, benchmark tests that include command overhead or measure logical seeks may produce results that vary from these specifications.

## 2.7 Start/stop times

Power-on to Ready (sec)	15 (max)
Standby to Ready (sec)	15 (max)
Ready to spindle stop (sec)	10 (max)

## 2.8 Power specifications

The drive receives DC power (+5V or +12V) through a four-pin standard drive power connector.

### 2.8.1 Power consumption

Power requirements for the drives are listed in the table on page 15. Typical power measurements are based on an average of drives tested, under nominal conditions, using +5.0V and +12.0V input voltage at 25°C ambient temperature.

- **Spinup power**

Spinup power is measured from the time of power-on to the time that the drive spindle reaches operating speed.

- **Seek mode**

During seek mode, the read/write actuator arm moves toward a specific position on the disc surface and does not execute a read or write operation. Servo electronics are active. Seek mode power represents the worst-case power consumption, using only random seeks with read or write latency time. This mode is not typical and is provided for worst-case information.

- **Read/write power and current**

Read/write power is measured with the heads on track, based on a 16-sector write followed by a 32-msec delay, then a 16-sector read followed by a 32-msec delay.

- **Operating power and current**

Operating power is measured using 40 percent random seeks, 40 percent read/write mode (1 write for each 10 reads) and 20 percent drive idle mode.

- **Idle mode power**

Idle mode power is measured with the drive up to speed, with servo electronics active and with the heads in a random track location.

- **Standby mode**

During Standby mode, the drive accepts commands, but the drive is not spinning, and the servo and read/write electronics are in power-down mode.

**Table 5: DC power requirements**

<b>Power dissipation (4-Disc values shown)</b>	<b>Average (watts, 25° C)</b>	<b>Average 5V typ amps</b>	<b>Average 12V typ amps</b>
Spinup	—	—	2.80 (peak)
Idle*	9.30	0.611	0.520
Idle with offline activity	10.40	0.719	0.567
Operating (40% r/w, 40% seek, 20% inop.)	13.00	0.772	0.762
Seeking (random, 20% idle)	12.60	0.613	0.795
Standby	0.80	0.106	0.023
Sleep	0.80	0.106	0.023

\*During periods of drive idle, some offline activity may occur according to the S.M.A.R.T. specification, which may increase acoustic and power to operational levels.

### 2.8.1.1 Typical current profile

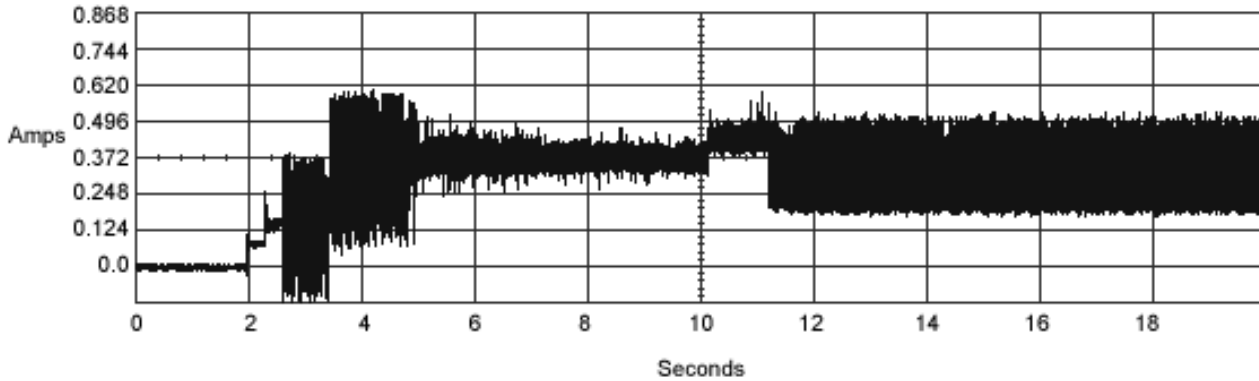

Figure 1 Typical 5V startup and operation current profile

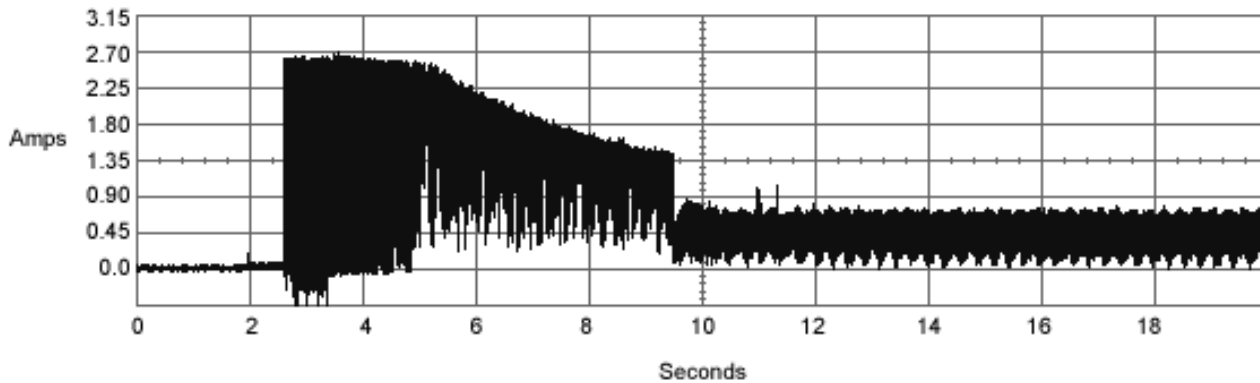

Figure 2 Typical 12V startup and operation current profile

### 2.8.2 Conducted noise

Input noise ripple is measured at the host system power supply across an equivalent 80-ohm resistive load on the +12 volt line or an equivalent 15-ohm resistive load on the +5 volt line.

- Using 12-volt power, the drive is expected to operate with a maximum of 120 mV peak-to-peak square-wave injected noise at up to 10 MHz.
- Using 5-volt power, the drive is expected to operate with a maximum of 100 mV peak-to-peak square-wave injected noise at up to 10 MHz.

**Note.** Equivalent resistance is calculated by dividing the nominal voltage by the typical RMS read/write current.



### 2.8.3 Voltage tolerance

Voltage tolerance (including noise):

5V ± 5%  
12V ± 10%

### 2.8.4 Power-management modes

The drive provides programmable power management to provide greater energy efficiency. In most systems, you can control power management through the system setup program. The drive features the following power-management modes:

Power mode	Heads	Spindle	Buffer
Active	Tracking	Rotating	Enabled
Idle	Tracking	Rotating	Enabled
Standby	Parked	Stopped	Enabled
Sleep	Parked	Stopped	Disabled

- **Active mode**

The drive is in Active mode during the read/write and seek operations.

- **Idle mode**

The buffer remains enabled, and the drive accepts all commands and returns to Active mode any time disc access is necessary.

- **Standby mode**

The drive enters Standby mode when the host sends a Standby Immediate command. If the host has set the standby timer, the drive can also enter Standby mode automatically after the drive has been inactive for a specifiable length of time. The standby timer delay is established using a Standby or Idle command. In Standby mode, the drive buffer is enabled, the heads are parked and the spindle is at rest. The drive accepts all commands and returns to Active mode any time disc access is necessary.

- **Sleep mode**

The drive enters Sleep mode after receiving a Sleep command from the host. In Sleep mode, the drive buffer is disabled, the heads are parked and the spindle is at rest. The drive leaves Sleep mode after it receives a Hard Reset or Soft Reset from the host. After receiving a reset, the drive exits Sleep mode and enters Standby mode with all current translation parameters intact.

- **Idle and Standby timers**

Each time the drive performs an Active function (read, write or seek), the standby timer is reinitialized and begins counting down from its specified delay times to zero. If the standby timer reaches zero before any drive activity is required, the drive makes a transition to Standby mode. In both Idle and Standby mode, the drive accepts all commands and returns to Active mode when disc access is necessary.

## 2.9 Environmental specifications

### 2.9.1 Ambient temperature

Ambient temperature is defined as the temperature of the environment immediately surrounding the drive. Actual drive case temperature should not exceed 69°C (156°F) within the operating ambient conditions. Recommended measurement locations are shown in See Figure 6 on page 29.

Above 1,000 feet (305 meters), the maximum temperature is derated linearly to 112°F (44°C) at 10,000 feet (3,048 meters).

Operating:	5° to 60°C (41° to 140°F)
Nonoperating:	-40° to 70°C (-40° to 158°F)

### 2.9.2 Temperature gradient

Operating:	20°C per hour (68°F per hour max), without condensation
Nonoperating:	30°C per hour (86°F per hour max)

### 2.9.3 Humidity

#### 2.9.3.1 Relative humidity

Operating:	5% to 90% noncondensing (30% per hour max)
Nonoperating:	5% to 95% noncondensing (30% per hour max)

#### 2.9.3.2 Wet bulb temperature

Operating:	37.7°C (99.9°F max)
Nonoperating:	37.7°C (99.9°F max)

### 2.9.4 Altitude

Operating:	-60.96 m to 3,048 m (-200 ft. to 10,000+ ft.)
Nonoperating:	-60.96 m to 12,192 m (-200 ft. to 40,000+ ft.)

## 2.9.5 Shock

All shock specifications assume that the drive is mounted securely with the input shock applied at the drive mounting screws. Shock may be applied in the X, Y or Z axis.

### 2.9.5.1 Operating shock

These drives comply with the performance levels specified in this document when subjected to a maximum operating shock of 68 Gs based on half-sine shock pulses of 2 msec. Shocks should not be repeated more than two times per second.

### 2.9.5.2 Nonoperating shock

The nonoperating shock level that the drive can experience without incurring physical damage or degradation in performance when subsequently put into operation is 300 Gs based on a nonrepetitive half-sine shock pulse of 2 msec duration.

## 2.9.6 Vibration

All vibration specifications assume that the drive is mounted securely with the input vibration applied at the drive mounting screws. Vibration may be applied in the X, Y or Z axis.

### 2.9.6.1 Operating vibration

The following table lists the maximum vibration levels that the drive may experience while meeting the performance standards specified in this document.

5–22 Hz	0.25 G (limited displacement)
22–350 Hz	0.50 G
350–500 Hz	0.25 G

### 2.9.6.2 Nonoperating vibration

The following table lists the maximum nonoperating vibration that the drive may experience without incurring physical damage or degradation in performance when subsequently put into operation.

5–22 Hz	0.25 G (limited displacement)
22–350 Hz	5.0 G
350–500 Hz	1.0 G

## 2.10 Acoustics

Drive acoustics are measured as overall A-weighted acoustic sound power levels (no pure tones). All measurements are consistent with ISO document 7779. Sound power measurements are taken under essentially free-field conditions over a reflecting plane. For all tests, the drive is oriented with the cover facing upward.

**Note.** For seek mode tests, the drive is placed in seek mode only. The number of seeks per second is defined by the following equation:

$$(\text{Number of seeks per second} = 0.4 / (\text{average latency} + \text{average access time}))$$

**Table 6: Fluid Dynamic Bearing (FDB) motor acoustics**

Acoustic mode		
	Idle*	Quiet seek
STM3320820A	2.7 Bels (typ) 3.0 Bels (max)	3.0 Bels (typ) 3.4 Bels (max)
STM3300620A STM3250820A STM3250620A STM3200820A	2.5 Bels (typ) 2.8 Bels (max)	3.0 Bels (typ) 3.1 Bels (max)

\*During periods of drive idle, some offline activity may occur according to the S.M.A.R.T. specification, which may increase acoustic and power to operational levels.

## 2.11 Electromagnetic immunity

When properly installed in a representative host system, the drive operates without errors or degradation in performance when subjected to the radio frequency (RF) environments defined in the following table:

**Table 7: Radio frequency environments**

Test	Description	Performance level	Reference standard
Electrostatic discharge	Contact, HCP, VCP: $\pm 4$ kV; Air: $\pm 8$ kV	B	EN 61000-4-2: 95
Radiated RF immunity	80 to 1,000 MHz, 3 V/m, 80% AM with 1 kHz sine 900 MHz, 3 V/m, 50% pulse modulation @ 200 Hz	A	EN 61000-4-3: 96 ENV 50204: 95
Electrical fast transient	$\pm 1$ kV on AC mains, $\pm 0.5$ kV on external I/O	B	EN 61000-4-4: 95
Surge immunity	$\pm 1$ kV differential, $\pm 2$ kV common, AC mains	B	EN 61000-4-5: 95
Conducted RF immunity	150 kHz to 80 MHz, 3 Vrms, 80% AM with 1 kHz sine	A	EN 61000-4-6: 97
Voltage dips, interrupts	0% open, 5 seconds 0% short, 5 seconds 40%, 0.10 seconds 70%, 0.01 seconds	C C C B	EN 61000-4-11: 94

## 2.12 Reliability

### 2.12.1 Annualized Failure Rate (AFR and Mean Time Between Failures (MTBF)

The product shall achieve an Annualized Failure Rate (AFR) of 0.34% (MTBF of 0.7 million hours) when operated in an environment of ambient air temperatures of 25°C. Operation at temperatures outside the specifications in Section 2.9 may increase the product AFR (decrease MTBF). AFR and MTBF are population statistics that are not relevant to individual units.

AFR and MTBF specifications are based on the following assumptions for desktop personal computer environments:

- 2400 power-on-hours per year.
- 10,000 average motor start/stop cycles per year.
- Operations at nominal voltages.
- Temperatures outside the specifications in Section 2.9 may reduce the product reliability.
- Normal I/O duty cycle for desktop personal computers. Operation at excessive I/O duty cycle may degrade product reliability.

The desktop personal computer environment of power-on-hours, temperature, and I/O duty cycle affect the product AFR and MTBF. The AFR and MTBF will be degraded if used in an enterprise application.

Nonrecoverable read errors	1 per 10 <sup>14</sup> bits read, max
Annualized Failure Rate (AFR)	0.34% (nominal power, 25°C ambient temperature)
Contact start-stop cycles	50,000 cycles (at nominal voltage and temperature, with 60 cycles per hour and a 50% duty cycle)
Warranty	3 years on distribution units. To determine the warranty for a specific drive, use a web browser to access the following web page: <a href="http://www.seagate.com/support/service/">www.seagate.com/support/service/</a> From this page, click on the "Verify Your Warranty" link. You will be asked to provide the drive serial number, model number (or part number) and country of purchase. The system will display the warranty information for your drive.
Preventive maintenance	None required.

## 2.13 Agency certification

### 2.13.1 Safety certification

The drives are recognized in accordance with UL 1950 and CSA C22.2 (950) and meet all applicable sections of IEC950 and EN 60950.

### 2.13.2 Electromagnetic compatibility

Hard drives that display the CE mark comply with the European Union (EU) requirements specified in the Electromagnetic Compatibility Directive (89/336/EEC). Testing is performed to the levels specified by the product standards for Information Technology Equipment (ITE). Emission levels are defined by EN 55022, Class B and the immunity levels are defined by EN 55024.

Drives are tested in representative end-user systems. Although CE-marked Seagate drives comply with the directives when used in the test systems, we cannot guarantee that all systems will comply with the directives. The drive is designed for operation inside a properly designed enclosure, with properly shielded I/O cable (if necessary) and terminators on all unused I/O ports. Computer manufacturers and system integrators should confirm EMC compliance and provide CE marking for their products.

## **Korean RRL**

If these drives have the Korea Ministry of Information and Communication (MIC) logo, they comply with paragraph 1 of Article 11 of the Electromagnetic Compatibility control Regulation and meet the Electromagnetic Compatibility (EMC) Framework requirements of the Radio Research Laboratory (RRL) Ministry of Information and Communication Republic of Korea.

These drives have been tested and comply with the Electromagnetic Interference/Electromagnetic Susceptibility (EMI/EMS) for Class B products. Drives are tested in a representative, end-user system by a Korean-recognized lab.

- Family name: DiamondMax
- Certificate number: Pending

## **Australian C-Tick (N176)**

If these models have the C-Tick marking, they comply with the Australia/New Zealand Standard AS/NZS3548 1995 and meet the Electromagnetic Compatibility (EMC) Framework requirements of the Australian Communication Authority (ACA).

### **2.13.3 FCC verification**

These drives are intended to be contained solely within a personal computer or similar enclosure (not attached as an external device). As such, each drive is considered to be a subassembly even when it is individually marketed to the customer. As a subassembly, no Federal Communications Commission verification or certification of the device is required.

Seagate Technology LLC has tested this device in enclosures as described above to ensure that the total assembly (enclosure, disc drive, motherboard, power supply, etc.) does comply with the limits for a Class B computing device, pursuant to Subpart J, Part 15 of the FCC rules. Operation with noncertified assemblies is likely to result in interference to radio and television reception.

Radio and television interference. This equipment generates and uses radio frequency energy and if not installed and used in strict accordance with the manufacturer's instructions, may cause interference to radio and television reception.

This equipment is designed to provide reasonable protection against such interference in a residential installation. However, there is no guarantee that interference will not occur in a particular installation. If this equipment does cause interference to radio or television, which can be determined by turning the equipment on and off, you are encouraged to try one or more of the following corrective measures:

- Reorient the receiving antenna.
- Move the device to one side or the other of the radio or TV.
- Move the device farther away from the radio or TV.
- Plug the computer into a different outlet so that the receiver and computer are on different branch outlets.

If necessary, you should consult your dealer or an experienced radio/television technician for additional suggestions. You may find helpful the following booklet prepared by the Federal Communications Commission: *How to Identify and Resolve Radio-Television Interference Problems*. This booklet is available from the Superintendent of Documents, U.S. Government Printing Office, Washington, DC 20402. Refer to publication number 004-000-00345-4.

## **2.14 Environmental protection**

Seagate designs its products to meet environmental protection requirements worldwide, including regulations restricting certain chemical substances.

### **2.14.1 European Union Restriction of Hazardous Substances (RoHS)**

The European Union Restriction of Hazardous Substances (RoHS) Directive restricts the presence of chemical substances, including Lead (Pb), in electronic products effective July 2006. Although amendments to the Euro-pean Union's Restriction of Hazardous Substances (RoHS) Directive have not been finalized, to the best of our knowledge the disc drives documented in this publication will comply with the final RoHS Directive requirements.

A number of parts and materials in Seagate products are procured from external suppliers. We rely on the rep-resentations of our suppliers regarding the presence of RoHS substances in these parts and materials. Our supplier contracts require compliance with our chemical substance restrictions, and our suppliers document their compliance with our requirements by providing material content declarations for all parts and materials for the disc drives documented in this publication. Current supplier declarations include disclosure of the inclusion of any RoHS-regulated substance in such parts or materials.

Seagate also has internal systems in place to ensure ongoing compliance with the RoHS Directive and all laws and regulations which restrict chemical content in electronic products. These systems include standard operat-ing procedures that ensure that restricted substances are not utilized in our manufacturing operations, laboratory analytical validation testing, and an internal auditing process to ensure that all standard operating procedures are complied with.

### **2.15 Corrosive environment**

Seagate electronic drive components pass accelerated corrosion testing equivalent to 10 years exposure to light industrial environments containing sulfurous gases, chlorine and nitric oxide, classes G and H per ASTM B845. However, this accelerated testing cannot duplicate every potential application environment. Users should use caution exposing any electronic components to uncontrolled chemical pollutants and corrosive chemicals as electronic drive component reliability can be affected by the installation environment. The silver, copper, nickel and gold films used in Seagate products are especially sensitive to the presence of sulfide, chlo-ride, and nitrate contaminants. Sulfur is found to be the most damaging. In addition, electronic components should never be exposed to condensing water on the surface of the printed circuit board assembly (PCBA) or exposed to an ambient relative humidity greater than 95%. Materials used in cabinet fabrication, such as vulca-nized rubber, that can outgas corrosive compounds should be minimized or eliminated. The useful life of any electronic equipment may be extended by replacing materials near circuitry with sulfide-free alternatives.



## 3.0 Configuring and mounting the drive

---

This section contains the specifications and instructions for configuring and mounting the drive.

### 3.1 Handling and static discharge precautions

After unpacking, and before installation, the drive may be exposed to potential handling and electrostatic discharge (ESD) hazards. Observe the following standard handling and static-discharge precautions:

**Caution:**

- Before handling the drive, put on a grounded wrist strap, or ground yourself frequently by touching the metal chassis of a computer that is plugged into a grounded outlet. Wear a grounded wrist strap throughout the entire installation procedure.
- Handle the drive by its edges or frame *only*.
- The drive is extremely fragile—handle it with care. Do not press down on the drive top cover.
- Always rest the drive on a padded, antistatic surface until you mount it in the computer.
- Do not touch the connector pins or the printed circuit board.
- Do not remove the factory-installed labels from the drive or cover them with additional labels. Removal voids the warranty. Some factory-installed labels contain information needed to service the drive. Other labels are used to seal out dirt and contamination.

### 3.2 Breather filter hole precautions

This section contains information regarding the precautions which should be taken regarding the breather filter hole in Seagate hard disc drives. Proper precautions should be taken to ensure full functionality and prevent possible damage to the drive.

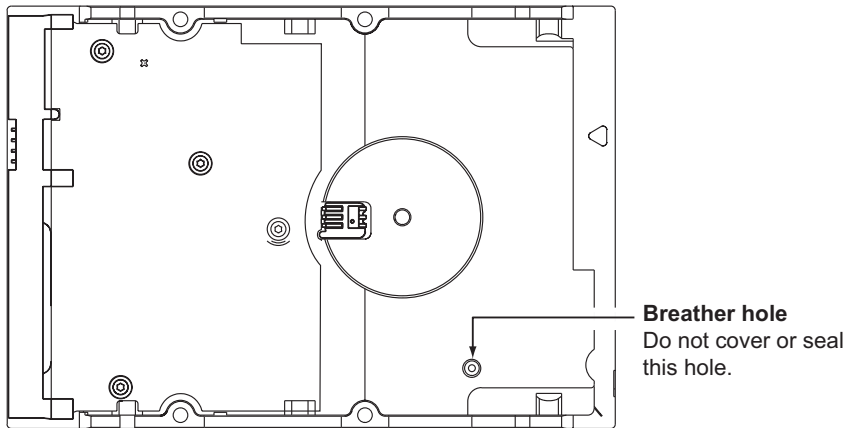

**Figure 3 Breather filter hole location**

**Caution: Do not cover, seal, or insert any object into this hole.**

This hole has two purposes:

- To allow condensation inside the hard disc to escape
- To allow air pressure inside the hard disc to equalize with ambient pressure

**Note.** If this hole is covered, sealed, or penetrated by any object, the drive reliability may be compromised and could lead to permanent damage. Covering or sealing this hole voids the warranty.

### 3.3 Jumper settings

#### 3.3.1 Master/slave configuration

The options jumper block shown in Figure 4 is used to configure the drive for operation. It is the 8-pin dual header between the interface connector and the power connector. Use the following settings to configure the drive as a master or a slave.

**Master or single drive.** The drive is configured at the factory for a master or single-drive operation with a jumper set on pins 7 and 8.

**Drive as slave.** Remove all jumpers.

**Drive as master with a non-ATA-compatible slave.**

Use this jumper setting *only* if the drive does not work as a master with no jumpers installed.

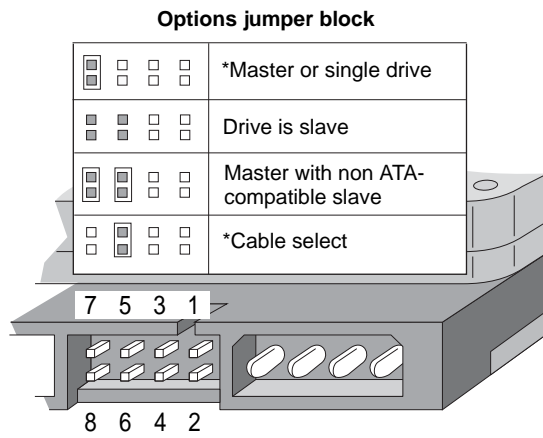

**Figure 4** Master/slave jumper settings

#### 3.3.2 Cable-select option

Computers that use cable select determine the master and slave drives by selecting or deselecting pin 28, CSEL, on the interface bus. Master and slave drives are determined by their physical position on the cable. To enable cable select, set a jumper on pins 5 and 6 as shown in Figure 4. Refer to your computer manual to determine whether your computer supports this option.

### 3.3.3 Ultra ATA/100 cable

An 80-conductor 40-pin cable is required to run Ultra DMA mode 3, mode 4, and mode 5. This cable uses even-numbered conductors connected to the ground pins to improve signal integrity.

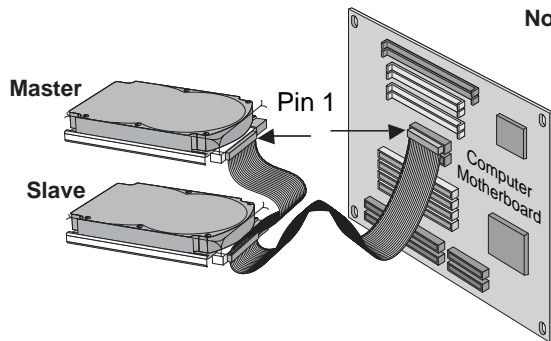

**Note.** If you are using a 40-pin, 80-conductor cable, attach the blue connector to the motherboard, the black connector to the master drive, and the gray connector to the slave.

**Figure 5** Ultra ATA cable connectors

**Note.** The drive supports both host and drive cable detection. The host detects the 80-conductor cable by sampling pin 34, CBLID-, on the interface bus. The drive detects the 80-conductor cable by sensing a capacitor at the host side through the CBLID- signal. The result is reported in a Fast Rise Detected bit (bit 13 of word 93 in the Identify drive parameter block).

### 3.4 Drive mounting

You can mount the drive in any orientation using four screws in the side-mounting holes or four screws in the bottom-mounting holes. See Figure 6 for drive mounting dimensions. Follow these important mounting precautions when mounting the drive:

- Allow a minimum clearance of 0.030 inches (0.76 mm) around the entire perimeter of the drive for cooling.
- Use only 6-32 UNC mounting screws.
- Do not overtighten the mounting screws (maximum torque: 6 inch-lb.).
- Do not use a drive interface cable that is more than 18 inches long.

**Notes:**

- 1. Dimensions are shown in inches (mm).
- 2. Dimensions per SFF-8301 specification.

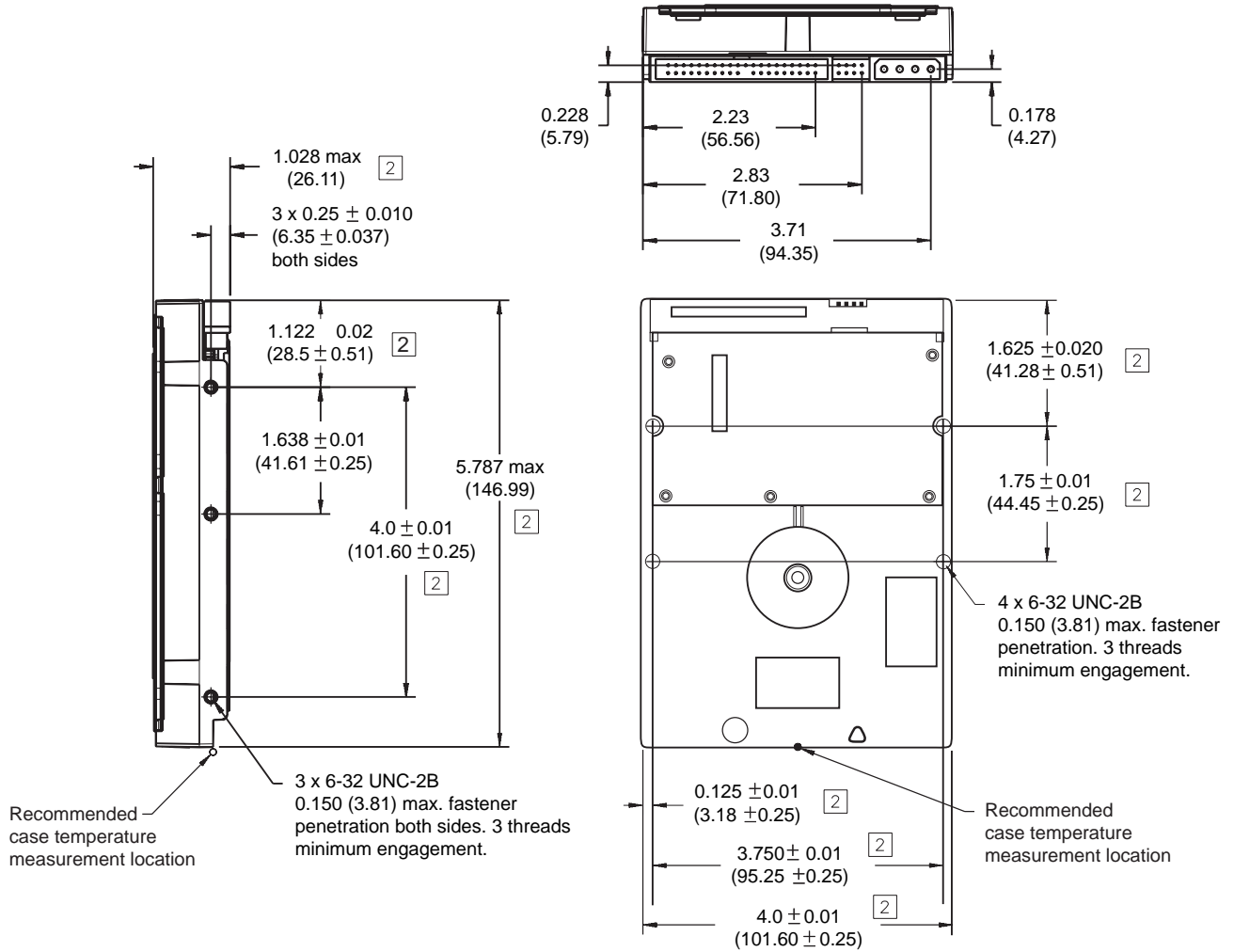

**Figure 6 Mounting dimensions**



## 4.0 ATA interface

These drives use the industry-standard ATA task file interface that supports 16-bit data transfers. It supports ATA programmed input/output (PIO) modes 0–4; multiword DMA modes 0–2, and Ultra DMA modes 0–5. The drive also supports the use of the IORDY signal to provide reliable high-speed data transfers.

You can use a daisy-chain cable to connect two drives to a single AT host bus. For detailed information about the ATA interface, refer to the draft of *AT Attachment with Packet Interface Extension (ATA/ATAPI-7)*, *NCITS T13 1410D*, subsequently referred to as the *Draft ATA-7 Standard*.

### 4.1 ATA interface signals and connector pins

Figure 7 on page 31 summarizes the signals on the ATA interface connector that the drive supports. For a detailed description of these signals, refer to the *Draft ATA-7 Standard*.

Drive pin #	Signal name	Host pin # and signal description
1	Reset-	1 Hardware Reset
2	Ground	2 Ground
3	DD7	3 Host Data Bus Bit 7
4	DD8	4 Host Data Bus Bit 8
5	DD6	5 Host Data Bus Bit 6
6	DD9	6 Host Data Bus Bit 9
7	DD5	7 Host Data Bus Bit 5
8	DD10	8 Host Data Bus Bit 10
9	DD4	9 Host Data Bus Bit 4
10	DD11	10 Host Data Bus Bit 11
11	DD3	11 Host Data Bus Bit 3
12	DD12	12 Host Data Bus Bit 12
13	DD2	13 Host Data Bus Bit 2
14	DD13	14 Host Data Bus Bit 13
15	DD1	15 Host Data Bus Bit 1
16	DD14	16 Host Data Bus Bit 14
17	DD0	17 Host Data Bus Bit 0
18	DD15	18 Device Data (15:0)
19	Ground	19 Ground
20	(removed)	20 (No Pin)
21	DMARQ	21 DMA Request
22	Ground	22 Ground
23	DIOW-	23 Device I/O Write: Stop Ultra DMA Burst
24	Ground	24 Ground
25	DIOR-	25 Device I/O Read: Host Ultra DMA Ready: Host Ultra DMA Data Strobe
26	Ground	26 Ground
27	IORDY	27 I/O Channel Ready
	DDMARDY-	Device Ultra DMA Ready
	DSTROBE	Device Ultra DMA Data Strobe
28	CSEL	28 Cable Select
29	DMACK-	29 DMA Acknowledge
30	Ground	30 Ground
31	INTRQ	31 Device Interrupt
32	IOCS16-	32 Reserved
33	DA1	33 Host Address Bus Bit 1
34	PDIAG-	34 Passed Diagnostics
	CBLID-	Cable Assembly Type Identifier
35	DA0	35 Device Address (2:0)
36	DA2	36 Device Address (2:0)
37	CS0-	37 Chip Select (1:0)
38	CS1-	38 Chip Select (1:0)
39	DASP-	39 Drive Active/Slave Present
40	Ground	40 Ground

Pins 28, 34 and 39 are used for master-slave communication (details shown below).

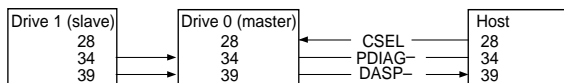

Figure 7 I/O pins and supported ATA signals

#### 4.1.1 Supported ATA commands

The following table lists ATA-standard commands that the drive supports. For a detailed description of the ATA commands, refer to the *Draft ATA-7 Standard*. See “S.M.A.R.T. commands” on page 38 for details and sub-commands used in the S.M.A.R.T. implementation.

**Table 8: Supported ATA commands**

Command name	Command code (in hex)
Check Power Mode	98 <sub>H</sub> or E5 <sub>H</sub>
Device Configuration Freeze Lock	B1 <sub>H</sub> / C1 <sub>H</sub>
Device Configuration Identify	B1 <sub>H</sub> / C2 <sub>H</sub>
Device Configuration Restore	B1 <sub>H</sub> / C0 <sub>H</sub>
Device Configuration Set	B1 <sub>H</sub> / C3 <sub>H</sub>
Device Reset	08 <sub>H</sub>
Download Microcode	92 <sub>H</sub>
Execute Device Diagnostics	90 <sub>H</sub>
Flush Cache	E7 <sub>H</sub>
Flush Cache Extended	EA <sub>H</sub>
Format Track	50 <sub>H</sub>
Identify Device	EC <sub>H</sub>
Idle	97 <sub>H</sub> or E3 <sub>H</sub>
Idle Immediate	95 <sub>H</sub> or E1 <sub>H</sub>
Initialize Device Parameters	91 <sub>H</sub>
Read Buffer	E4 <sub>H</sub>
Read DMA	C8 <sub>H</sub>
Read DMA Extended	25 <sub>H</sub>
Read DMA Without Retries	C9 <sub>H</sub>
Read Log Ext	2F <sub>H</sub>
Read Multiple	C4 <sub>H</sub>
Read Multiple Extended	29 <sub>H</sub>
Read Native Max Address	F8 <sub>H</sub>
Read Native Max Address Extended	27 <sub>H</sub>
Read Sectors	20 <sub>H</sub>
Read Sectors Extended	24 <sub>H</sub>
Read Sectors Without Retries	21 <sub>H</sub>
Read Verify Sectors	40 <sub>H</sub>
Read Verify Sectors Extended	42 <sub>H</sub>
Read Verify Sectors Without Retries	41 <sub>H</sub>
Recalibrate	10 <sub>H</sub>
Security Disable Password	F6 <sub>H</sub>
Security Erase Prepare	F3 <sub>H</sub>



Command name	Command code (in hex)
Security Erase Unit	F4 <sub>H</sub>
Security Freeze	F5 <sub>H</sub>
Security Set Password	F1 <sub>H</sub>
Security Unlock	F2 <sub>H</sub>
Seek	70 <sub>H</sub>
Set Features	EF <sub>H</sub>
Set Max Address Note: Individual Set Max Address commands are identified by the value placed in the Set Max Features register as defined to the right.	F9 <sub>H</sub> Address: 00 <sub>H</sub> Password: 01 <sub>H</sub> Lock: 02 <sub>H</sub> Unlock: 03 <sub>H</sub> Freeze Lock: 04 <sub>H</sub>
Set Max Address Extended	37 <sub>H</sub>
Set Multiple Mode	C6 <sub>H</sub>
Sleep	99 <sub>H</sub> or E6 <sub>H</sub>
S.M.A.R.T. Disable Operations	B0 <sub>H</sub> / D9 <sub>H</sub>
S.M.A.R.T. Enable/Disable Autosave	B0 <sub>H</sub> / D2 <sub>H</sub>
S.M.A.R.T. Enable Operations	B0 <sub>H</sub> / D8 <sub>H</sub>
S.M.A.R.T. Execute Offline	B0 <sub>H</sub> / D4 <sub>H</sub>
S.M.A.R.T. Read Attribute Thresholds	B0 <sub>H</sub> / D1 <sub>H</sub>
S.M.A.R.T. Read Data	B0 <sub>H</sub> / D0 <sub>H</sub>
S.M.A.R.T. Read Log Sector	B0 <sub>H</sub> / D5 <sub>H</sub>
S.M.A.R.T. Return Status	B0 <sub>H</sub> / DA <sub>H</sub>
S.M.A.R.T. Save Attribute Values	B0 <sub>H</sub> / D3 <sub>H</sub>
S.M.A.R.T. Write Log Sector	B0 <sub>H</sub> / D6 <sub>H</sub>
Standby	96 <sub>H</sub> or E2 <sub>H</sub>
Standby Immediate	94 <sub>H</sub> or E0 <sub>H</sub>
Write Buffer	E8 <sub>H</sub>
Write DMA	CA <sub>H</sub>
Write DMA Extended	35 <sub>H</sub>
Write DMA Without Retries	CB <sub>H</sub>
Write Log Extended	3F <sub>H</sub>
Write Multiple	C5 <sub>H</sub>
Write Multiple Extended	39 <sub>H</sub>
Write Sectors	30 <sub>H</sub>
Write Sectors Without Retries	31 <sub>H</sub>
Write Sectors Extended	34 <sub>H</sub>

#### 4.1.2 Identify Device command

The Identify Device command (command code EC<sub>H</sub>) transfers information about the drive to the host following power up. The data is organized as a single 512-byte block of data, whose contents are shown in the Table 8 on page 32. All reserved bits or words should be set to zero. Parameters listed with an “x” are drive-specific or vary with the state of the drive. See Section 2.0 on page 3 for default parameter settings.

The following commands contain drive-specific features that may not be included in the *Draft ATA-7 Standard*.

Word	Description	Value
0	Configuration information: • Bit 15: 0 = ATA; 1 = ATAPI • Bit 7: removable media • Bit 6: removable controller • Bit 0: reserved	0C5A <sub>H</sub>
1	Number of logical cylinders	16,383
2	ATA-reserved	0000 <sub>H</sub>
3	Number of logical heads	16
4	Retired	0000 <sub>H</sub>
5	Retired	0000 <sub>H</sub>
6	Number of logical sectors per logical track: 63	003F <sub>H</sub>
7–9	Retired	0000 <sub>H</sub>
10–19	Serial number: (20 ASCII characters, 0000 <sub>H</sub> = none)	ASCII
20	Retired	0000 <sub>H</sub>
21	Retired	0400 <sub>H</sub>
22	Obsolete	0000 <sub>H</sub>
23–26	Firmware revision (8 ASCII character string, padded with blanks to end of string)	x.xx
27–46	Drive model number (40 ASCII characters, padded with blanks to end of string)	MAXTOR STMxxxxxx
47	(Bits 7–0) Maximum sectors per interrupt on Read multiple and Write multiple (16)	8010 <sub>H</sub>
48	Reserved	0000 <sub>H</sub>
49	Standard Standby timer, IORDY supported and may be disabled	2F00 <sub>H</sub>
50	ATA-reserved	0000 <sub>H</sub>
51	PIO data-transfer cycle timing mode	0200 <sub>H</sub>
52	Retired	0200 <sub>H</sub>
53	Words 54–58, 64–70 and 88 are valid	0007 <sub>H</sub>
54	Number of current logical cylinders	xxxx <sub>H</sub>
55	Number of current logical heads	xxxx <sub>H</sub>
56	Number of current logical sectors per logical track	xxxx <sub>H</sub>
57–58	Current capacity in sectors	xxxx <sub>H</sub>
59	Number of sectors transferred during a Read Multiple or Write Multiple command	xxxx <sub>H</sub>

Word	Description	Value
60–61	Total number of user-addressable LBA sectors available (see Section 2.2 for related information) *Note: The maximum value allowed in this field is: 0FFFFFFFh (268,435,455 sectors, 137 Gbytes). Drives with capacities over 137 Gbytes will have 0FFFFFFFh in this field and the actual number of user-addressable LBAs specified in words 100-103. This is required for drives that support the 48-bit addressing feature.	0FFFFFFFh*
62	Retired	0000 <sub>H</sub>
63	Multiword DMA active and modes supported (see note following this table)	xx07 <sub>H</sub>
64	Advanced PIO modes supported (modes 3 and 4 supported)	0003 <sub>H</sub>
65	Minimum multiword DMA transfer cycle time per word (120 nsec)	0078 <sub>H</sub>
66	Recommended multiword DMA transfer cycle time per word (120 nsec)	0078 <sub>H</sub>
67	Minimum PIO cycle time without IORDY flow control (240 nsec)	00F0 <sub>H</sub>
68	Minimum PIO cycle time with IORDY flow control (120 nsec)	0078 <sub>H</sub>
69–74	ATA-reserved	0000 <sub>H</sub>
75	Queue depth	0000 <sub>H</sub>
76–79	SATA-specific	xxxx <sub>H</sub>
80	Major version number	007E <sub>H</sub>
81	Minor version number	0000 <sub>H</sub>
82	Command sets supported	346B <sub>H</sub>
83	Command sets supported	7D01 <sub>H</sub>
84	Command sets support extension	4003 <sub>H</sub>
85	Command sets enabled	34xx <sub>H</sub>
86	Command sets enabled	3xxx <sub>H</sub>
87	Command sets enable extension	4003 <sub>H</sub>
88	Ultra DMA support and current mode (see note following this table)	xx3F <sub>H</sub>
89	Security erase time	0000 <sub>H</sub>
90	Enhanced security erase time	0000 <sub>H</sub>
92	Master password revision code	FFFE <sub>H</sub>
93	Hardware reset value (see description following this table)	xxxx <sub>H</sub>
95–99	ATA-reserved	0000 <sub>H</sub>
100–103	Total number of user-addressable LBA sectors available (see Section 2.2 for related information). These words are required for drives that support the 48-bit addressing feature. Maximum value: 0000FFFFFFFFFh.	STM3320820A = 625,142,448 STM3300620A = 586,072,368 STM3250820A = 488,397,168 STM3250620A = 488,397,168 STM3200820A = 390,721,968
104–127	ATA-reserved	0000 <sub>H</sub>
128	Security status	0001 <sub>H</sub>
129–159	Seagate-reserved	xxxx <sub>H</sub>
160–254	ATA-reserved	0000 <sub>H</sub>

Word	Description	Value
255	Integrity word	xxA5 <sub>H</sub>

**Note.** Advanced Power Management (APM) and Automatic Acoustic Management (AAM) features are not supported

**Note.** See the bit descriptions below for words 63, 88, and 93 of the Identify Drive data:

Description (if bit is set to 1)		
	<b>Bit</b>	<b>Word 63</b>
	0	Multiword DMA mode 0 is supported.
	1	Multiword DMA mode 1 is supported.
	2	Multiword DMA mode 2 is supported.
	8	Multiword DMA mode 0 is currently active.
	9	Multiword DMA mode 1 is currently active.
	10	Multiword DMA mode 2 is currently active.
	<b>Bit</b>	<b>Word 88</b>
	0	Ultra DMA mode 0 is supported.
	1	Ultra DMA mode 1 is supported.
	2	Ultra DMA mode 2 is supported.
	3	Ultra DMA mode 3 is supported.
	4	Ultra DMA mode 4 is supported.
	5	Ultra DMA mode 5 is supported.
	8	Ultra DMA mode 0 is currently active.
	9	Ultra DMA mode 1 is currently active.
	10	Ultra DMA mode 2 is currently active.
	11	Ultra DMA mode 3 is currently active.
	12	Ultra DMA mode 4 is currently active.
	13	Ultra DMA mode 5 is currently active.
	<b>Bit</b>	<b>Word 93</b>
	13	1 = 80-conductor cable detected, CBLID above V <sub>IH</sub> 0 = 40-conductor cable detected, CBLID below V <sub>IL</sub>

### 4.1.3 Set Features command

This command controls the implementation of various features that the drive supports. When the drive receives this command, it sets BSY, checks the contents of the Features register, clears BSY and generates an interrupt. If the value in the register does not represent a feature that the drive supports, the command is aborted. Power-on default has the read look-ahead and write caching features enabled. The acceptable values for the Features register are defined as follows:

02 <sub>H</sub>	Enable write cache ( <i>default</i> ).
03 <sub>H</sub>	Set transfer mode (based on value in Sector Count register). Sector Count register values:
00 <sub>H</sub>	Set PIO mode to default (PIO mode 2).
01 <sub>H</sub>	Set PIO mode to default and disable IORDY (PIO mode 2).
08 <sub>H</sub>	PIO mode 0
09 <sub>H</sub>	PIO mode 1
0A <sub>H</sub>	PIO mode 2
0B <sub>H</sub>	PIO mode 3
0C <sub>H</sub>	PIO mode 4 ( <i>default</i> )
20 <sub>H</sub>	Multiword DMA mode 0
21 <sub>H</sub>	Multiword DMA mode 1
22 <sub>H</sub>	Multiword DMA mode 2
40 <sub>H</sub>	Ultra DMA mode 0
41 <sub>H</sub>	Ultra DMA mode 1
42 <sub>H</sub>	Ultra DMA mode 2
43 <sub>H</sub>	Ultra DMA mode 3
44 <sub>H</sub>	Ultra DMA mode 4
45 <sub>H</sub>	Ultra DMA mode 5
55 <sub>H</sub>	Disable read look-ahead (read cache) feature.
82 <sub>H</sub>	Disable write cache.
AA <sub>H</sub>	Enable read look-ahead (read cache) feature ( <i>default</i> ).
F1 <sub>H</sub>	Report full capacity available

**Note.** At power-on, or after a hardware or software reset, the default values of the features are as indicated above.

#### 4.1.4 S.M.A.R.T. commands

S.M.A.R.T. provides near-term failure prediction for disc drives. When S.M.A.R.T. is enabled, the drive monitors predetermined drive attributes that are susceptible to degradation over time. If self-monitoring determines that a failure is likely, S.M.A.R.T. makes a status report available to the host. Not all failures are predictable. S.M.A.R.T. predictability is limited to the attributes the drive can monitor. For more information on S.M.A.R.T. commands and implementation, see the *Draft ATA-7 Standard*.

SeaTools diagnostic software activates a built-in drive self-test (DST S.M.A.R.T. command for D4<sub>H</sub>) that eliminates unnecessary drive returns. The diagnostic software ships with all new drives and is also available at: <http://seatools.seagate.com>.

This drive is shipped with S.M.A.R.T. features disabled. You must have a recent BIOS or software package that supports S.M.A.R.T. to enable this feature. The table below shows the S.M.A.R.T. command codes that the drive uses.

Code in features register	S.M.A.R.T. command
D0 <sub>H</sub>	S.M.A.R.T. Read Data
D2 <sub>H</sub>	S.M.A.R.T. Enable/Disable Attribute Autosave
D3 <sub>H</sub>	S.M.A.R.T. Save Attribute Values
D4 <sub>H</sub>	S.M.A.R.T. Execute Off-line Immediate (runs DST)
D5 <sub>H</sub>	S.M.A.R.T. Read Log Sector
D6 <sub>H</sub>	S.M.A.R.T. Write Log Sector
D8 <sub>H</sub>	S.M.A.R.T. Enable Operations
D9 <sub>H</sub>	S.M.A.R.T. Disable Operations
DA <sub>H</sub>	S.M.A.R.T. Return Status

**Note.** If an appropriate code is not written to the Features Register, the command is aborted and 0x04 (abort) is written to the Error register.

## 5.0 Maxtor support services

---

Before contacting Maxtor Support, use the Hard Disk Information feature in MaxBlast to view the model number and serial number of your drive. These numbers can be used to get help from Maxtor Support, register your drive, and look up information on the Maxtor website.

Please visit [www.maxtor.com](http://www.maxtor.com) to obtain comprehensive support information, such as:

- **Warranty services**  
Drive returns, warranty status, and limited warranty statement.
- **Product support**  
Installation tutorials, specifications, jumper settings, installation guides, and product manuals.
- **Software downloads**  
Installation software, utilities, and diagnostics.
- **Knowledge Base**  
Troubleshooting information, FAQs, and resolved problem database.
- **Product Index**  
Current and legacy Maxtor products listing.

Click on Worldwide Support to access the Knowledge Base, download software updates, register your drive, and get assistance via e-mail.





# Index

## A

acoustics 20  
Active mode 17  
AFR 22  
agency certification (regulatory) 22  
altitude 18  
ambient conditions 3  
ambient temperature 14, 18  
Annualized Failure Rate 22  
Annualized Failure Rate (AFR) 22  
areal density 1, 13  
ATA interface 31  
ATA-standard commands 32  
Australian C-Tick 23  
autodetection 1  
average seek time 14

## B

BPI 13  
breather filter hole precautions 26  
burst 1

## C

cable 28  
cable select 1  
cable-select option 27  
cache 1  
case temperature 18  
CE mark 22  
certification 22  
Check Power Mode 32  
commands 32  
conducted noise 16  
conducted RF immunity 21  
configuring the drive 25  
connector pins 31  
connectors 28  
Corrosive environment 24  
CSA C22.2 (950) 22  
CSEL 27  
C-Tick 23  
current profile 16  
cycles 22

## D

data-transfer rates 1  
DC power 14  
density 13  
Device Configuration Freeze Lock 32  
Device Configuration Identify 32

Device Configuration Restore 32  
Device Configuration Set 32  
Device Reset 32  
diagnostic software 1, 38  
dissipation 15  
Download Microcode 32  
drive diagnostics 14  
drive monitoring 1  
drive self-test 1, 38  
DST 38  
duty cycle 22

## E

electrical fast transient 21  
electromagnetic compatibility 22  
Electromagnetic Compatibility Directive 22  
electromagnetic immunity 21  
electrostatic discharge 21  
EMC compliance 22  
EN 60950 22  
enclosures 23  
environmental specifications 18  
EPRML 1, 13  
error-correction algorithms 1  
errors 22  
European Union 22  
Execute Device Diagnostics 32

## F

failure prediction 38  
FCC verification 23  
Features register 37  
Flush Cache 32  
Flush Cache Extended 32  
Format Track 32  
formatted capacity 12  
frequency 21

## G

guaranteed sectors 12

## H

handling 25  
heads 1  
height 13  
humidity 18

## I

I/O data-transfer rate 13  
I/O duty cycle 22  
Identify Device 32  
Identify Device command 34  
Idle 32

Idle and Standby timers 17  
Idle Immediate 32  
Idle mode 17  
Idle mode power 15  
IEC950 22  
Information Technology Equipment 22  
Initialize Device Parameters 32  
interface 13, 31  
interface signals 31  
interference 23  
internal data-transfer rate OD 13  
ISO document 7779 20

## J

jumper settings 27

## K

Korean RRL 23

## L

LBA mode 12  
length 13  
logical geometry 12

## M

maintenance 22  
master 27  
master/slave 1  
Master/slave configuration 27  
maximum temperature 18  
Mean Time Between Failures 22  
measurement locations 18  
modes 31  
monitoring 1  
mounting the drive 25, 28  
MTBF 22

## N

noise 16  
nominal power 3  
nonoperating shock 19  
nonoperating vibration 19  
Nonrecoverable read errors 22

## O

operating power and current 14  
operating shock 19  
operating vibration 19  
orientation 28

## P

physical characteristics 13  
pins 31  
PIO 31  
power consumption 14  
power dissipation 15  
power management 17  
power specifications 14  
power-management modes 17  
Power-on to Ready 14  
power-on-hours 22  
precautions 28  
programmable power management 17

## R

radiated RF immunity 21  
radio and television interference 23  
radio frequency 21  
random track location 15  
Read Buffer 32  
Read DMA 32  
Read DMA Extended 32  
Read DMA without Retries 32  
read errors 22  
Read Log Ext 32  
Read Multiple 1, 32  
Read Multiple Extended 32  
Read Native Max Address 32  
Read Native Max Address Extended 32  
Read Sectors 32  
Read Sectors Extended 32  
Read Sectors Without Retries 32  
Read Verify Sectors 32  
Read Verify Sectors Extended 32  
Read Verify Sectors Without Retries 32  
read/write power and current 14  
Recalibrate 32  
recording and interface technology 13  
recording density 13  
recording heads 1  
recording method 13  
register 37  
relative humidity 18  
reliability 22  
resistance 16  
resistive load 16  
RF 21  
RoHS 24

## S

- S.M.A.R.T. commands 38
- S.M.A.R.T. Disable Operations 33
- S.M.A.R.T. drive monitoring 1
- S.M.A.R.T. Enable/Disable Autosave 33
- S.M.A.R.T. Enable Operations 33
- S.M.A.R.T. Execute Offline 33
- S.M.A.R.T. Read Attribute Thresholds 33
- S.M.A.R.T. Read Data 33
- S.M.A.R.T. Read Log Sector 33
- S.M.A.R.T. Return Status 33
- S.M.A.R.T. Save Attribute Values 33
- S.M.A.R.T. Write Log sector 33
- safety certification 22
- screws 28
- SeaTools 1, 38
- sectors 12
- Security Disable Password 32
- Security Erase Prepare 32
- Security Erase Unit 33
- Security Freeze 33
- Security Set Password 33
- Security Unlock 33
- Seek 33
- seek mode 14
- seek time 14
- Seeking 15
- servo electronics 15
- Set Features 33
- Set Features command 37
- Set Max Address 33
- Set Max Address Extended 33
- Set Multiple Mode 33
- shock 19
- signals 31
- single-track seeks 14
- slave 27
- Sleep 15, 33
- Sleep mode 17
- sound 20
- specifications 3
- spindle speed 13
- Spinup 15
- spinup power 14
- Standby 15, 33
- Standby Immediate 33
- Standby mode 15, 17
- Standby to Ready 14
- start/stop times 14
- start-stop cycles 22
- static-discharge precautions 25
- stop times 14
- subassembly 23
- support services 39
- surge immunity 21

## T

- technical support services 39
- temperature 18
- temperature gradient 18
- TGMR 1
- timers 17
- track density 13
- track-to-track seek time 14

## U

- UL 1950 22
- Ultra ATA/100 28
- Ultra DMA 28

## V

- vibration 19
- voltage 17
- voltage dips, interrupts 21
- voltage tolerance 17

## W

- Warranty 22
- weight 13
- wet bulb temperature 18
- width 13
- Write Buffer 33
- Write DMA 33
- Write DMA Extended 33
- Write DMA Without Retries 33
- Write Log Extended 33
- Write Multiple 1, 33
- Write Multiple Extended 33
- Write Sectors 33
- Write Sectors Extended 33
- Write Sectors Without Retries 33







**Maxtor Corporation**  
**920 Disc Drive, Scotts Valley, California 95066-4544, USA**  
*Publication Number: 100435213, Rev. A, Printed in U.S.A.*