

Diaphragms for seismic loading

A philosophy for analysis and design

By Rafael Sabelli, P.E., S.E.; Warren Pottebaum, S.E.; and Brian Dean, LEED AP

All structural engineers familiar with building design know, diaphragms constitute an integral part of the lateral load resisting system. When the load under consideration is seismic, the diaphragms themselves often constitute a majority of the inertial mass, as well as the means of delivering inertial forces to the vertical elements of the seismic load resisting system (SLRS). While building codes have paid careful attention to diaphragm design, this area remains rife with ambiguity and differing opinions. This article will not put an end to such debate, of course, but will serve as one example of a coherent philosophy of diaphragm design for seismic loading.

Analysis

We will discuss both analysis and design details; the analysis portion is provided here and the design portion will be provided at www.gostructural.com.

Vertical distribution of seismic forces

In general, buildings are analyzed using either an Equivalent Lateral Force (ELF) analysis, a Modal Response Spectrum (MRS) analysis,

or a Nonlinear Response History (NRH) analysis. This article addresses ELF analysis, with some discussion of the techniques used in MRS analysis.

ELF analysis — The design of the SLRS requires that the design base shear be considered to be delivered as story forces at each diaphragm. The ELF procedure provides an equation for the vertical distribution of forces. Minimum Design Loads for Buildings and Other Structures, ASCE 7-05 (Eq. 12.8-12) defines this distribution. It is purposefully top-heavy: It generally overestimates the overturning moment compared with MRS or NRH analysis. In this way it ensures both sufficient overturning and shear strength for the vertical elements of the SLRS. However, at the same time it vastly underestimates how much force enters the frames at lower levels.

Eq. 12.8-12 can be thought of as representing primarily the first mode of vibration of the structure while discounting the contributions of higher modes. For higher modes, the reversing directions impose significant forces on the frames at lower levels. These forces are not addressed explicitly by Eq. 12.8-12. Instead, ASCE 7-05 contains

a special equation for diaphragm design: Eq. 12.10-1. This latter equation provides a distribution that better represents the forces that the diaphragms at any level in the building might be subjected to as a result of higher mode excitation. Similar to Eq. 12.8-12, Eq. 12.10-1 utilizes the design base shear to determine diaphragm forces and is

thus implicitly based on the system type. The difference between the equations is more pronounced at lower levels. Figure 1 shows the force distributions corresponding to Eq. 12.8-12 (a) and 12.10-1 (b) for a regular structure with similar floor masses.

MRS analysis — Rather than use the somewhat approximate Eq. 12.10-1 to capture higher-mode response, some engineers have proposed using MRS analysis to determine diaphragm accelerations from which design forces can be determined. ASCE 7-05 does not formally recognize this analytical method for diaphragm design; however, it is allowed for the determination of component forces in Eq. 13.3-4.

Engineers must always be careful to extract meaningful information from MRS analysis. Quantities of interest must be tracked mode by mode and combined using an appropriate combination rule, typically the square root of the sum of the squares (SRSS) or the complete quadratic combination (CQC). Subtracting the modal combination of story shears at one level from modal combination of story shear at the level below does not represent the MRS analysis story force; rather, this force is properly determined by calculating the story force mode by mode and then performing the appropriate combination. Current versions of popular software are much easier to use than older ones when extracting this information.

Diaphragm forces

Note that in both cases (ELF and MRS analysis), the base shear, and thus the diaphragm force, includes a reduction due to response modification coefficient (R) to which the building frame system is assigned. The members of the building frame are detailed

Figure 1: Force distributions

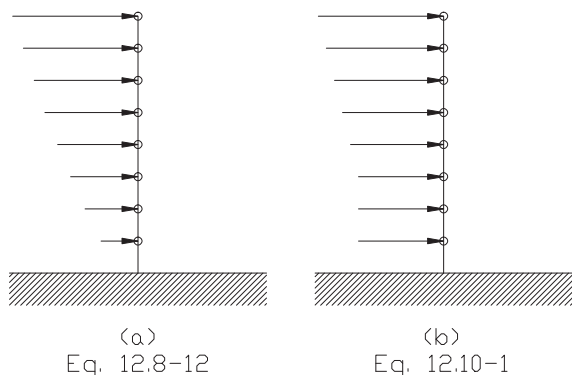

to provide the ductility corresponding to the assigned response modification coefficient. However, the diaphragm does not necessarily offer the same level of ductility, and therefore the design forces also should be different from that based on the lateral analysis used for frame design.

ASCE 7-05 provides upper and lower bounds for the diaphragm forces determined from Eq. 12.10-1. These bounds are independent of the design base shear and thus of the system type selected. The lower bound typically applies to structures with a low base shear, either due to a longer period, a high response reduction coefficient R , or a combination of the two. This lower bound represents the effects of higher modes that generate little base shear. The upper bound governs for structures with opposite characteristics: a high base shear, either due to a short period, a low response reduction coefficient R , or a combination of the two. The upper bound represents elastic response or limited inelastic response. These limits apply to diaphragm forces calculated using either ELF or MRS analysis.

Diaphragm classification

Once the diaphragm force has been determined, the diaphragm itself must be analyzed. The total force (for example, from Eq. 12.10-1) can be distributed in accordance with the distribution of the mass whose acceleration the force represents. The path that this distributed load follows depends on the diaphragm classification: flexible, rigid, or semi-rigid. These classifications relate diaphragm flexibility to that of the vertical elements of the SLRS.

For diaphragms to be considered flexible they must meet one of the conditions defined in Sections 12.3.1.1 and 12.3.1.3:

- Diaphragms constructed of un-topped steel decking or wood structural panels when the vertical elements are steel or composite steel and concrete braced frames, or concrete, masonry, steel, or composite shear walls;

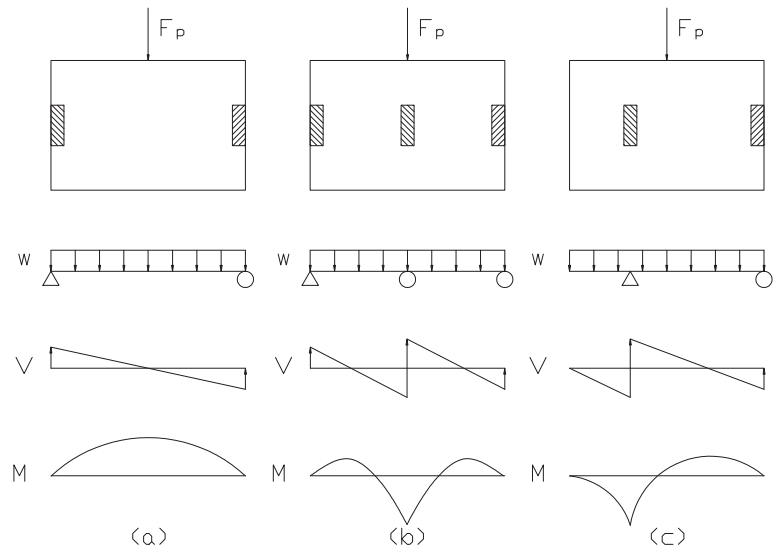

(above) Figure 2: Diaphragm as beam

(below) Figure 3: Linear collector diaphragm

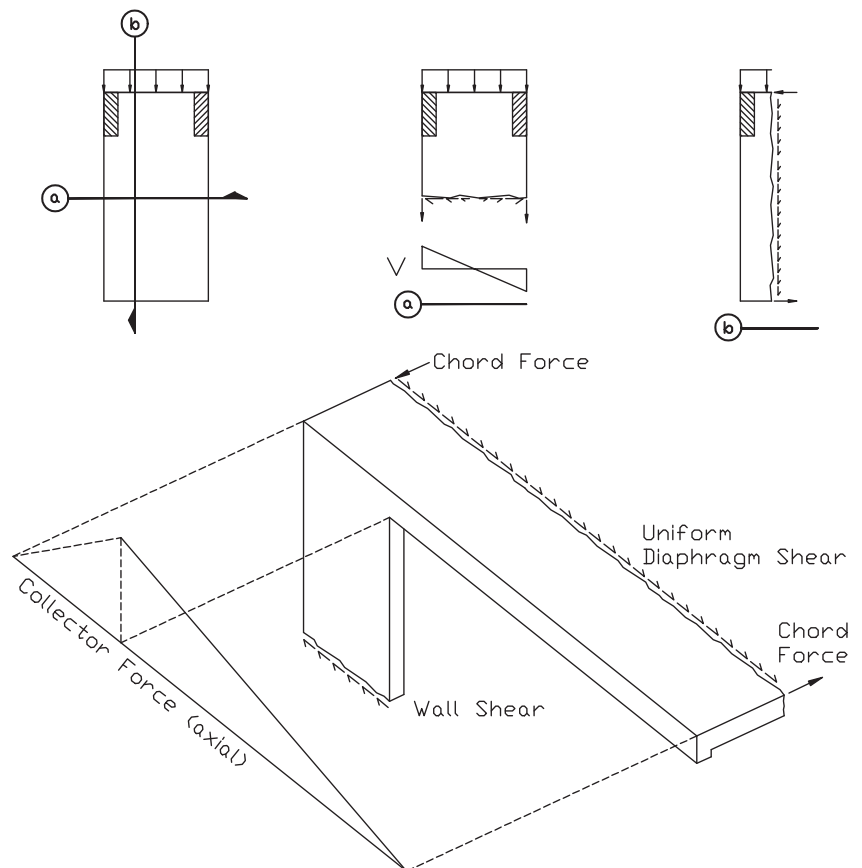

- Diaphragms of wood structural panels or untopped steel decks in one and two-family residential buildings of light-frame construction; and
- Diaphragms for which the computed maximum in-plane deflection of the diaphragm itself under lateral load is at least twice the average story drift of adjoining vertical elements of the SLRS.

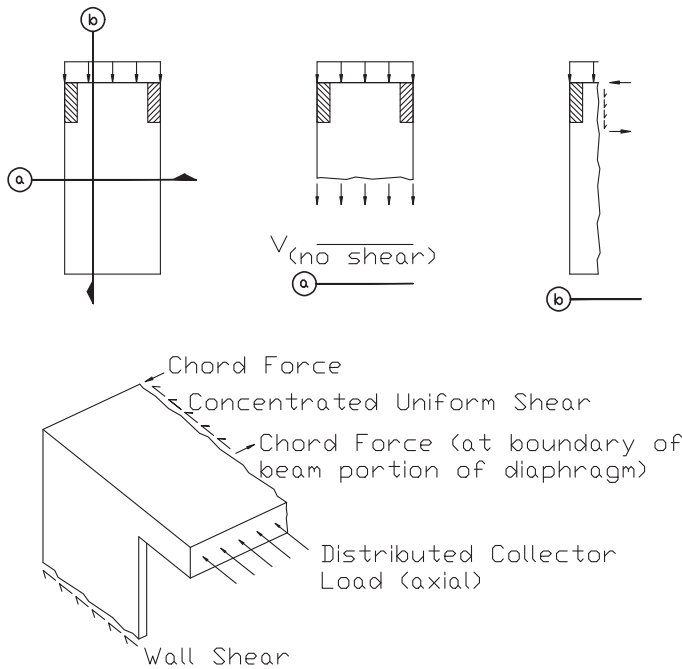

(above) Figure 4: Distributed collector diaphragm

(below) Figure 5: Distributed collector diaphragm with a collector zone

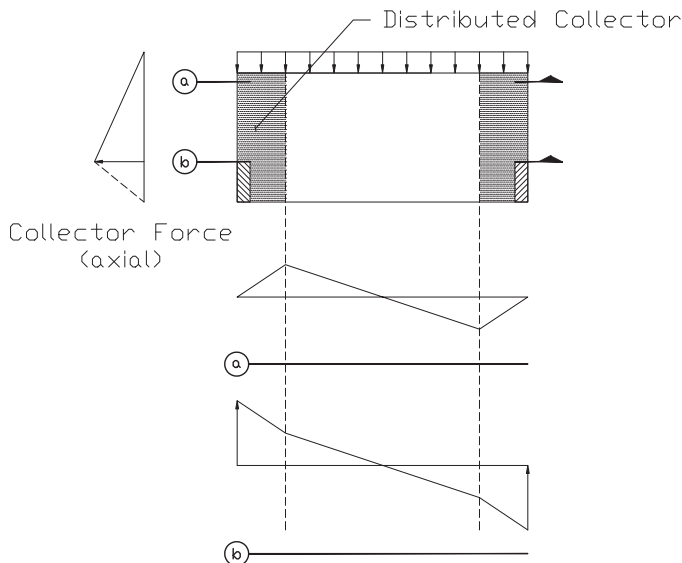

At the opposite extreme, diaphragms may be idealized as rigid under certain circumstances, per Section 12.3.1.2: Diaphragms of concrete slabs or concrete-filled metal deck with span-to-depth ratios of 3 or less in structures that have no horizontal irregularities.

It is assumed that no matter the lateral system, such diaphragms will have sufficient stiffness to deliver forces in a manner consistent with the rigid diaphragm assumption. Under extreme cases of very rigid shear wall structures this may not be the case, but generally the consequences of this inaccuracy in modeling are not significant for either the diaphragm or the vertical elements.

Diaphragms not classified as either rigid or flexible are required to be considered “semi rigid” per Section 12.3.1. Furthermore, this section requires “explicit” consideration and specifies a “semi-rigid modeling assumption.” Diaphragms must be analyzed as membrane (or shell or plate) elements and the vertical elements must be modeled or represented by springs of the appropriate stiffness. (While this level of modeling is implicitly based on the assumption of elastic behavior — which is incorrect — ASCE 7 is unambiguous with regard to this requirement.)

Diaphragm analysis

The analysis of flexible diaphragms is fairly straightforward. They are analyzed as beams and the elements of the SLRS are considered to be rigid supports. Figure 2 shows schematics of this type of beam analysis for (a) simply supported, (b) multi-span, and (c) cantilevered diaphragms. Reactions are determined without considering the flexibility of the vertical elements of the SLRS.

Note that in diagrams (b) and (c), where the diaphragm loads a vertical element from both sides, the shear transfer to the vertical element (or its collector) is the sum of the diaphragm shear on the two sides. Although the diaphragm itself may not be overstressed, the shear transfer to the collector may require as much as twice the number of connections (welds, screws, nails, et cetera) as is required to resist the diaphragm shear.

In either non-flexible case (rigid or semi-rigid diaphragms) a structural analysis is required to determine the horizontal distribution of forces. The building model used for the analysis of the vertical elements of the SLRS can be employed to determine this horizontal distribution. Once the forces entering the vertical elements of SLRS have been determined, the diaphragm is analyzed to establish a load path between the inertial mass and the vertical elements (see the section below on redistribution of forces). This analysis need not be a rigorous analysis based on the diaphragm elastic properties. It should be noted that elastic analyses are not

necessarily any more accurate, let alone more appropriate, than other methods for systems that are subject to inelastic deformation.

Numerous analytical methods are permissible for diaphragm design as long as there is a reasonably direct load path between the inertial mass and the vertical elements; some analytical methods may not be applicable to diaphragms of certain composition.

Common diaphragm analytical methods include Linear-Collector Diaphragm (LCD) and Distributed-Collector Diaphragm (DCD) analysis. Other analytical methods, such as Strut-and-Tie Diaphragm (S&T) analysis, are also permissible.

In each of these methods the diaphragm force is considered to be a distributed load on the diaphragm, which acts as a beam or a truss that spans between (or over, or past) its supports (the vertical elements). This

distributed load is determined by the distribution of mass; it is typically constant for a rectangular diaphragm. The forces transferred to the vertical elements of the SLRS are reactions. In flexible diaphragm analysis engineers can begin with the distributed loading and calculate reactions. In the analysis of systems with rigid or semi-rigid diaphragms, reactions are determined from the building analysis and the shears and moments in the diaphragm “beam” or “truss” are derived to be consistent with these reactions.

Linear-collector diaphragm (LCD) — In the LCD method the diaphragm is analyzed as a beam. Reactions represent forces acting on the vertical elements. The shear diagram of the beam represents a distributed shear in the diaphragm, assumed to be of constant value across its entire depth. The moment diagram represents forces in the diaphragm boundaries, which act

as a tension-compression couple separated by the diaphragm depth.

The forces entering the vertical elements are assumed to be collected in beams aligned with these elements. A line of collector beams is typically provided running the full depth of the diaphragm. Forces in this collector beam line begin at zero at the diaphragm edge and increase linearly up to the point where the vertical elements take the forces. For braced frames this occurs as a single point or a series of points where the braces connect; for moment frames this occurs at the column locations; and for shear walls this occurs in a distributed fashion (see Figure 3).

This linearly increasing force is collected from the diaphragm in shear; thus the diaphragm is assumed to have uniform shear across its depth. This shear is at its maximum adjacent to the collectors and reduces to zero at a section between collector lines (or at the

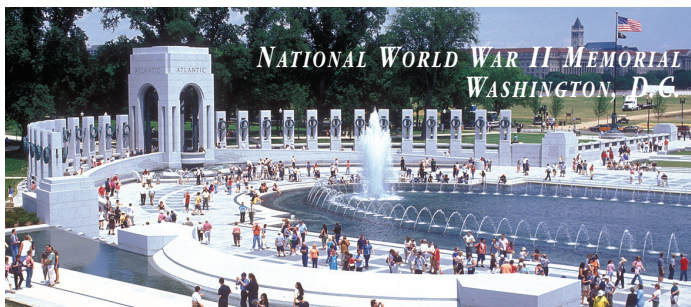

SUPPORTING THE WWII MEMORIAL FOR THE AGES . . .

proven corrosion protection required . . .

Epoxy-coated steel reinforcing bars were specified and used in a structure dominated by bronze and granite—materials known for durability. This project’s performance criteria was very stringent: aesthetic appeal, strength and durability, defined not in years but in generations.

Commonly, epoxy-coated steel reinforcing is used in transportation structures where protection against the effects of chlorides is desired. However, for this structure, to be viewed by thousands of visitors a day and located in a chronically moist environment, epoxy-coated steel reinforcing was selected for strength, durability and its corrosion protection to maintain the aesthetics for years.

Build with quality . . . specify a CRSI Certified Epoxy Coater.

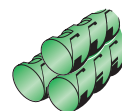

EPOXY GROUP

Epoxy Interest Group of CRSI

Concrete Reinforcing Steel Institute
933 N. Plum Grove Road
Schaumburg, Illinois 60173-4758
847/517-1200 Fax: 847/517-1206
Website: www.crsi.org/epoxy

© 2008 Epoxy Interest Group of CRSI

Enter #141 at gostructural.com/infodirect

edge of a cantilever diaphragm). Diaphragm shear capacity can be uniform, or it can be varied to better correspond with shear demands.

This shear also causes forces to develop in the diaphragm boundary members that are perpendicular to the collectors. These act as the chord members of a deep truss, and their forces can be determined by analyzing the diaphragm as a beam spanning between (or over, or past) supports, and dividing the moment by the depth of the diaphragm. (Often these chord members also act as collectors for orthogonal loading.) (see Figure 2).

Distributed-collector diaphragm (DCD) — This diaphragm analysis

method is similar to the LCD analysis. However, the DCD method reduces the calculated collector forces by relying more on the diaphragm shear capacity. In this method the reaction at the vertical elements is assumed to be delivered in shear over a limited portion of the diaphragm depth. In some cases, a short collector line is required; in others the length of the frame or shearwall is sufficient. The minimum length of this portion is determined by the shear capacity of the diaphragm.

The concentration of shear in a portion of the diaphragm depth results in a reduced depth for resisting the moment (at least locally), and some localized chord forces develop. Additionally, a

mechanism is required to deliver the force to the areas of the diaphragm acting in shear. In one extreme, the entire width of the diaphragm can be considered to act as a distributed collector, and a limited portion of the diaphragm can be considered to act as the beam (with the reduced depth resulting in higher chord forces); see Figure 4.

If the entire depth of the diaphragm is used to compute chord forces at the point of maximum moment, the DCD method requires a detailed consideration of the load path from the localized shear and chord forces near the vertical elements to the chord forces at the diaphragm boundary. Typically, the DCD technique is used to determine a collector width sufficient to keep stresses low enough to avoid the need for confinement in concrete (per ACI 318-08 Section 21.11.7.5). In this case, the high shear occurs in only a small region of the diaphragm (see Figure 5), and a collector zone exists within the diaphragm, similar to a collector beam in a LCD.

Strut-and-tie diaphragm (S&TD) — Strut-and-tie models are covered in Appendix A of ACI 318-08, which is applicable to concrete diaphragms. When used in a diaphragm analysis, the model includes struts that go from the distributed inertial mass to the vertical elements. These struts are diagonals cutting across the diaphragm. The mass is considered to be excited in a direction parallel to the vertical elements. At the mass end of the diagonal a component of force is generated in the direction orthogonal to the excitation of loading; similarly, an opposite force is generated at the vertical elements. A distributed load system such as is the case in diaphragm design must be discretized (see Figure 6); additionally, the strut-and-tie behavior must be reanalyzed for loading in the opposite direction. The design methodology for S&TD is not well developed in published references.

A prudent precaution — Each of these analytical techniques assumes certain mechanisms of resistance within the diaphragm. A prudent

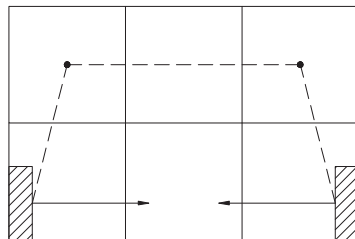
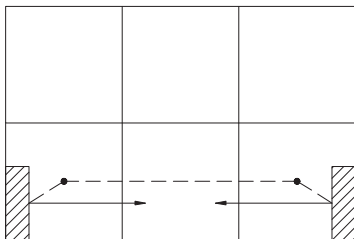
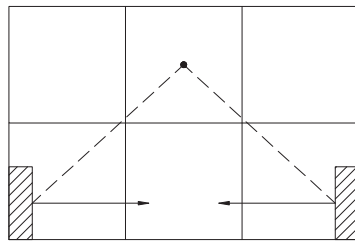
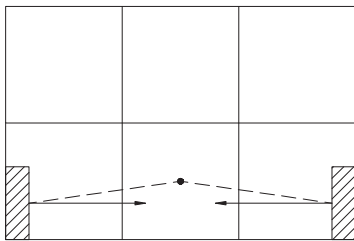

(above) Figure 6: Discretized strut-and-tie diaphragm

(below) Figure 7: Vertical load distributions

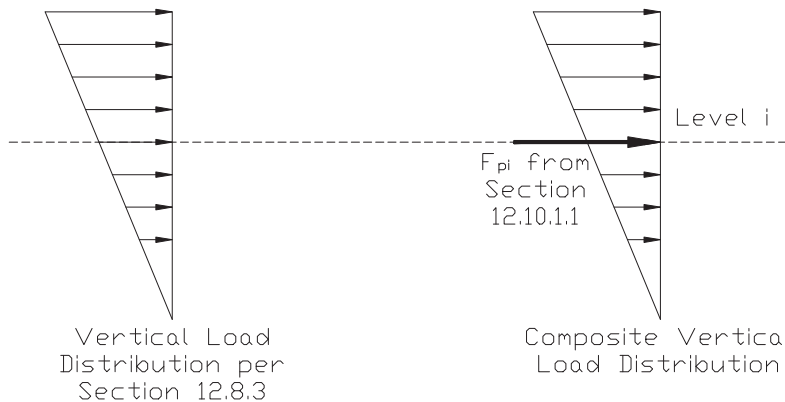

designer will also consider the alternate load paths between the inertial mass and the vertical elements, and provide both positive connections and ductile detailing along these paths. For example, in LCD designs, cross-ties within the diaphragm should be provided, either as reinforcement in concrete slabs or composite decks, or as discrete member connections for metal-deck diaphragms, or as straps in plywood diaphragms. Likewise, increased shear reinforcement should be considered near the vertical elements if the calculated demand is near the calculated capacity. For DCD and S&TD designs, additional longitudinal and transverse reinforcement in line with the vertical elements should be considered to ensure the integrity of the diaphragm is maintained. In this way, large cracks or connection failures within the diaphragm can be avoided.

Coupling of chords and collectors

In certain situations, multiple loading conditions can affect certain members of the diaphragm. ASCE 7-05 does not require consideration of this; nevertheless, understanding when these conditions may occur will ensure that designers consider these effects when appropriate.

The most common such condition when the beam serves as a collector for one direction of loading and as a chord for loading in the orthogonal direction. If a MRS analysis is used to determine forces in these members (and they are not attached at both ends to a rigid diaphragm in the model), proper combination of orthogonal analyses will account for this; ELF analysis does not unless the designer combines the forces using an appropriate combination (per Section 12.5).

A less common condition is building torsion. Where frames in both orthogonal directions are engaged in resisting building torsion, loading in both orthogonal directions will engage the same collector lines. This effect is typically very small except where the

diaphragm would be unstable without the orthogonal vertical elements.

Redistribution of forces

Designers, always eager to streamline their work, have developed methods of repurposing the ELF vertical analysis (which uses the distribution from Eq. 12.8-12) to represent the diaphragm forces from Eq. 12.10-1. One common method involves simply amplifying collector forces from the former analysis by the ratio of F_{px} (from Eq. 12.10-1) to F_x (from Eq. 12.8-12). This procedure is valid solely in cases in which the only forces in the diaphragm are those generated by inertial mass at that level. Where seismic forces from other levels are redistributed in a diaphragm this method will produce inaccurate results by amplifying these forces as well. The degree to which this method overestimates the collector forces depends on the relative magnitudes of the inertial forces generated by excitation of the diaphragm and of the forces being redistributed. Where there is a decrease in the frame shear from the level above or, in the extreme case, where a frame is discontinuous, this method can be substantially unconservative.

A more accurate method involves scaling the diaphragm forces based on the increase in story shear from the ELF vertical force distribution to a modified ELF vertical force distribution, in which the story force F_x (from Eq. 12.8-12) has been replaced with the diaphragm design force F_{px} (from Eq. 12.10-1) at the level under consideration. This is shown diagrammatically in Figure 7.

At a given level i of a multi-story structure, the diaphragm force at a particular frame j can be derived from analysis results as the difference between the frame shear below that level, V_i , and the frame shear above that level, V_{i+1} . To convert these results, which correspond to the ELF vertical force distribution, to the modified vertical force distribution described above, the diaphragm force at frame j is calculated as follows:

$F_{pij} = \gamma_i \rho V_{ij} - \rho V_{i+1,j}$, and the story shear ratio γ_i is calculated as follows:

$$\gamma_i = \frac{F_{pi} + \rho \sum_{x=i+1}^N F_x}{\rho \sum_{x=i}^N F_x}$$

By scaling the frame shear below level i by the factor γ_i and leaving the frame shear above level i unscaled, that portion of the diaphragm force that is due to redistribution from levels above is not amplified. One should note this method assumes that the centers of mass are aligned vertically at all floor levels. If there are large offsets in the center of mass (for example, because of a stepped building profile) it is necessary to use a similar approach to scale the torsional moment.

Design

“Design of diaphragms for seismic loading” is Part 2 of this article; it will be printed in February 2009 in *Structural Engineer*.

Acknowledgements

This discussion originated at the Seismology Committee of the Structural Engineers Association of Northern California in 2001. Additionally, several structural engineers have shared their practices and methodologies, and some of these have been incorporated into the methods described above. ▼

Rafael Sabelli, P.E., S.E., is director of seismic design at Walter P Moore. He can be reached at 415-963-6300 or via e-mail at rsabelli@walterpmoore.com. Warren Potterbaum, S.E., is an associate at DASSE Design. He can be reached at 510-433-9370 or via e-mail at pottebaum@dasse.com. Brian Dean, LEED AP, is a graduate engineer at Walter P Moore and can be reached at 415-963-6300 or via e-mail at bdean@walterpmoore.com.