

Dillon RL 550B Casefeeder

Installation Instructions

May 2007



Exploded View, Dillon RL 550B Casefeeder

ITEM #	PART #	DESCRIPTION	QTY.
1	96002	550 CF LOWER FEEDER ASSEMBLY	1
2	--	CASEFEED ADAPTOR (NOT INCLUDED)	0
3	18911	550 CASEFEED CAM	1
4	18908	550 CF LOWER CF TUBE	1
5	96001	550 CF UPPER BOWL ASSEMBLY	1
6	18910	550 CF UPPER CF TUBE	1
7	17124	POST	1
8	18907	550 CF POST SUPPORT	1
9	14457	MOUNTING HARDWARE	1
10	13713	ALIGNMENT FIXTURE	1
11	19056	550CF MICROSWITCH HOUSING INSERT	1

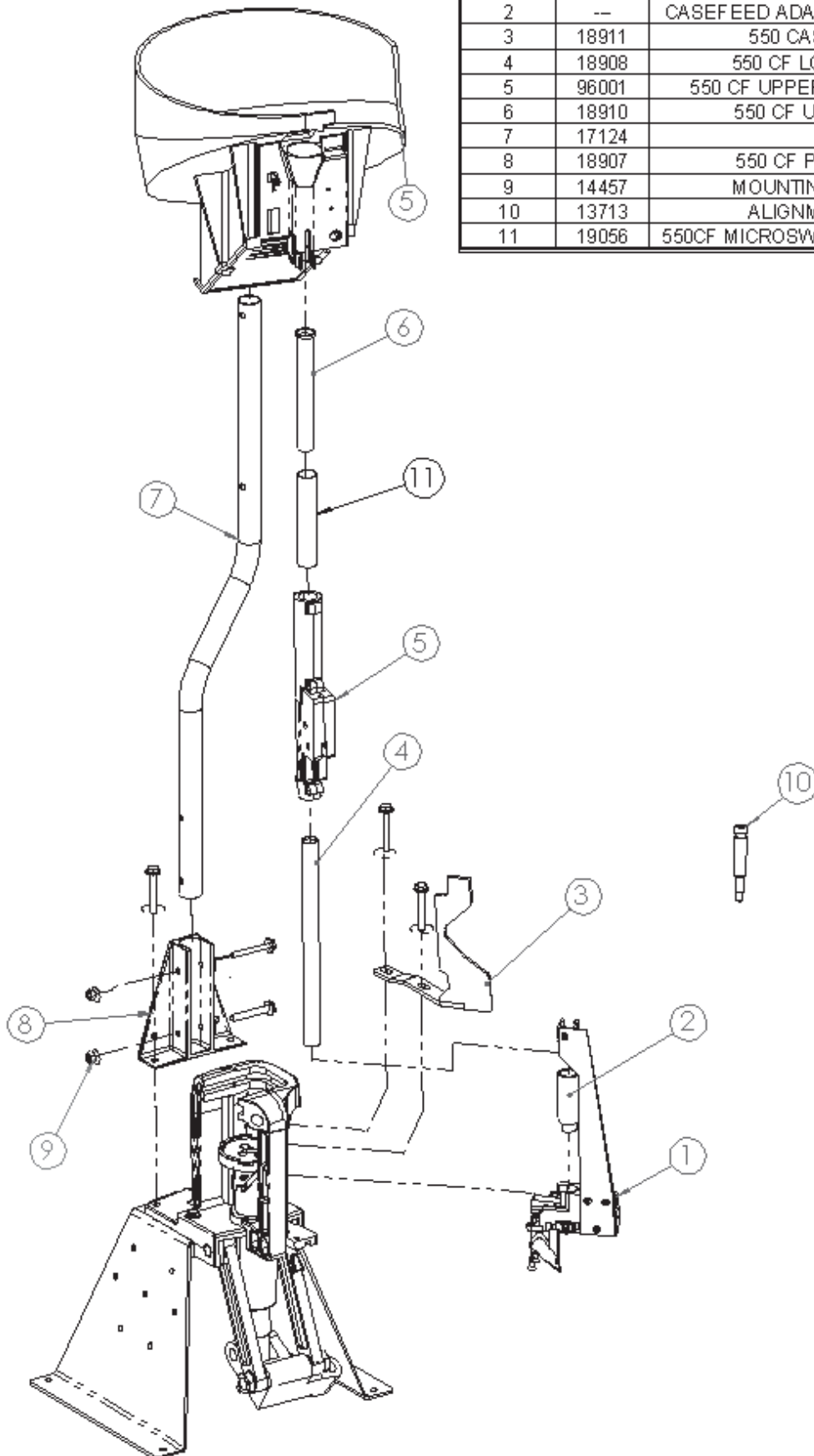

Congratulations on your purchase of Dillon's RL 550 B Casefeeder. Please take a moment to read through these instructions carefully before installing the casefeeder on your machine.

1. Check the contents of the box and verify that all parts have been supplied. Refer to the exploded view on the opposite page.

Hardware Kit: Part #14457

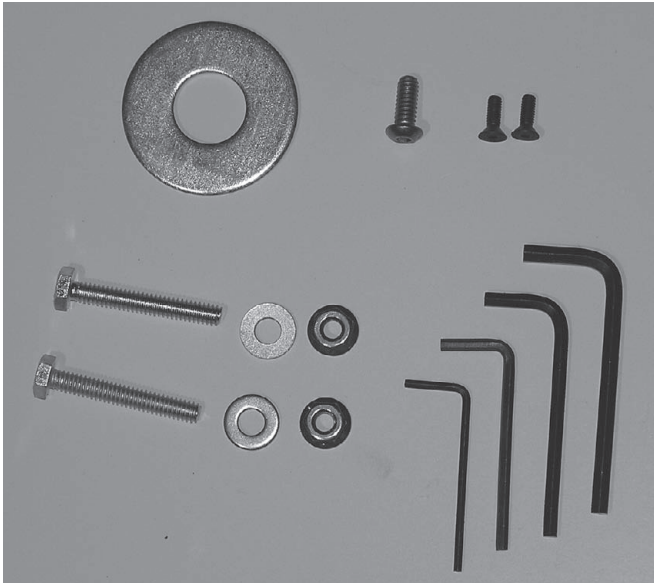

Hardware Kit Contents	
Description	Qty.
1/4 - 20 x 1 3/4 Hex Cap Screw	2
1/4 washer	2
1/4 -20 Flanged Nut	2
8-32 x 1/2 Countersunk Flathead	2
1/4 -20 x 5/8 Button Head Cap Screw	1
13/16 Washer	1
3/16 Allen Wrench	1
5/32 Allen Wrench	1
1/8 Allen Wrench	1
3/32 Allen Wrench	1

Additional Tools Needed:

- Two 7/16" wrenches

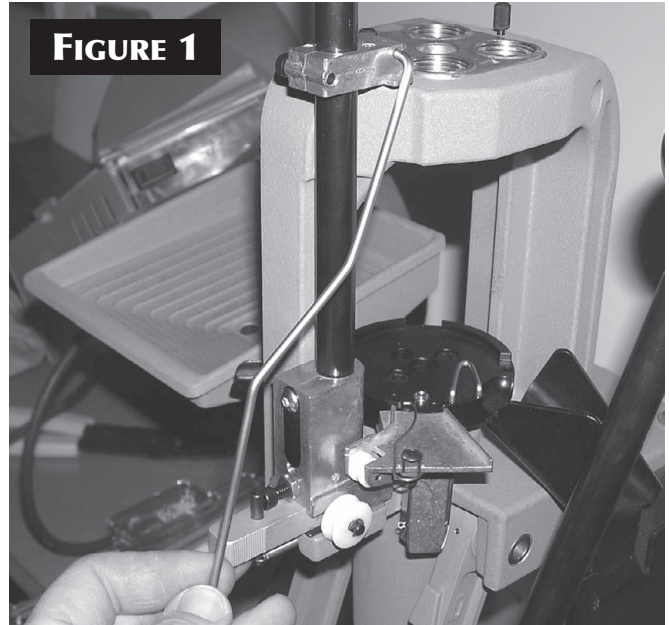

FIGURE 1

2. Begin by removing the operating rod from the primer system [FIGURE 1].

3. Next, remove the cartridge chute [FIGURE 2] (applicable for machines with strong mount only), shellplate, index ball, spring and toolhead [FIGURE 3] from your machine.

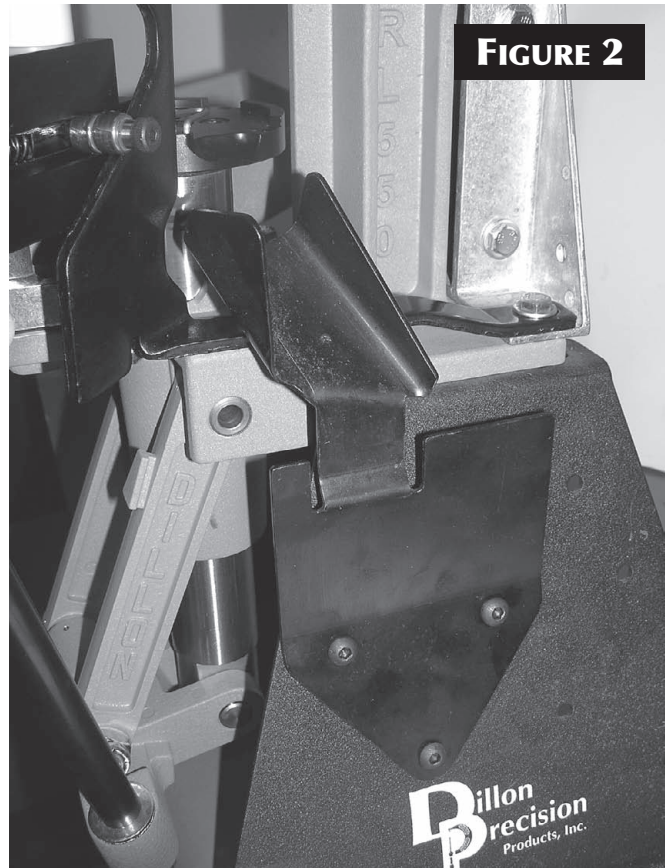

FIGURE 2

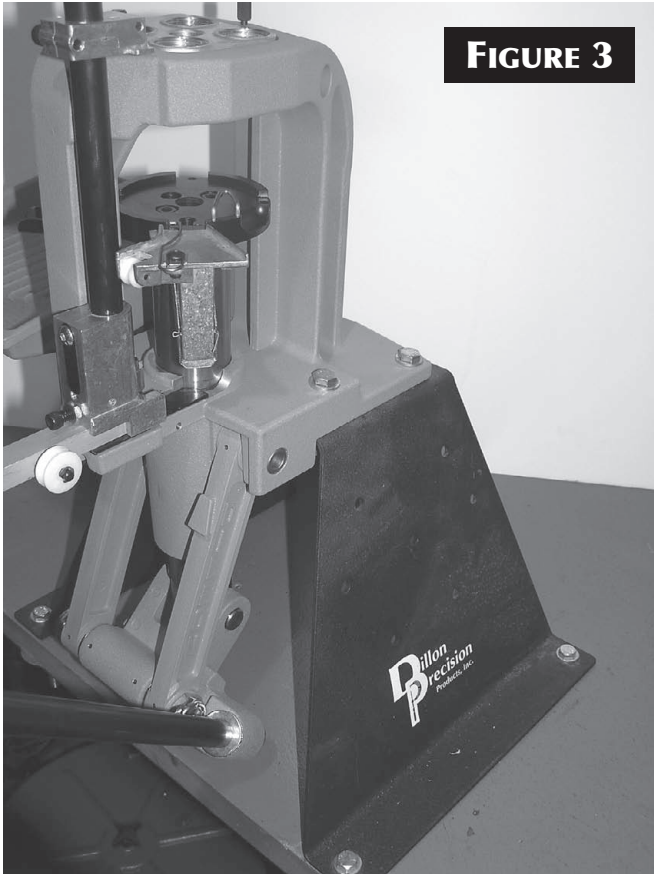

FIGURE 3

screws located toward the center of the platform, with the supplied 3/16" Allen wrench. Once you have the platform off the machine, disassemble the roller bracket from the platform [FIGURE 4] by removing the two flat head screws, with the supplied 3/32" Allen wrench.

4. Next, remove the platform assembly [FIGURE 4] from the machine. This is accomplished by removing the two cap



FIGURE 5

5. Attach the new 550 CF Lower Feeder Assembly (part #96002) to the platform [FIGURE 5] with the new 8-32 x 1/2" flat head socket screws and Allen wrench provided in the hardware package – be sure to tighten.

6. Re-attach the platform and Casefeeder housing to the shaft (make sure not to forget the failsafe return bracket), only lightly tighten screws at this point. You will need to use an empty toolhead with a powder die in the station 1 position and the supplied alignment tool as shown in

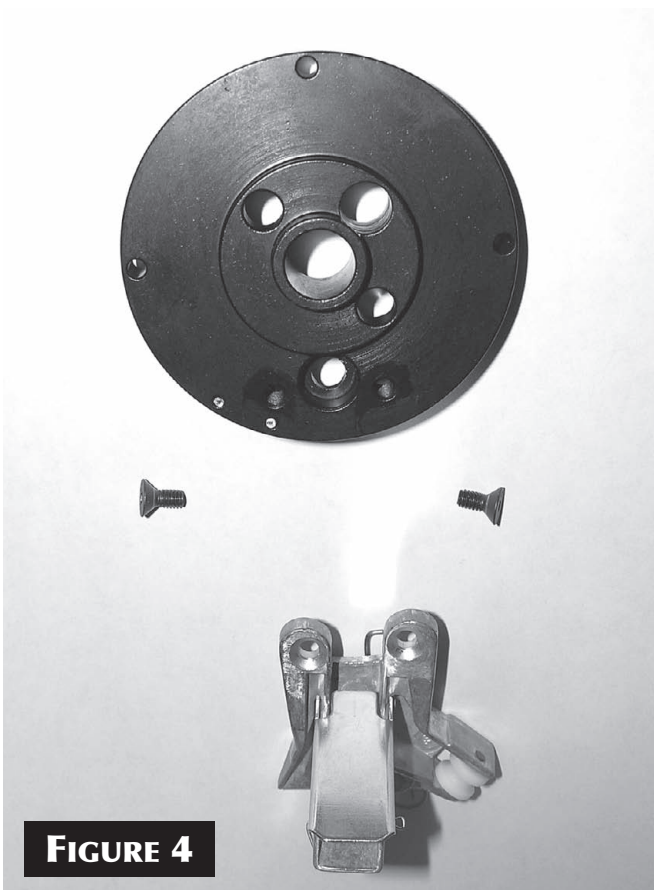

FIGURE 4

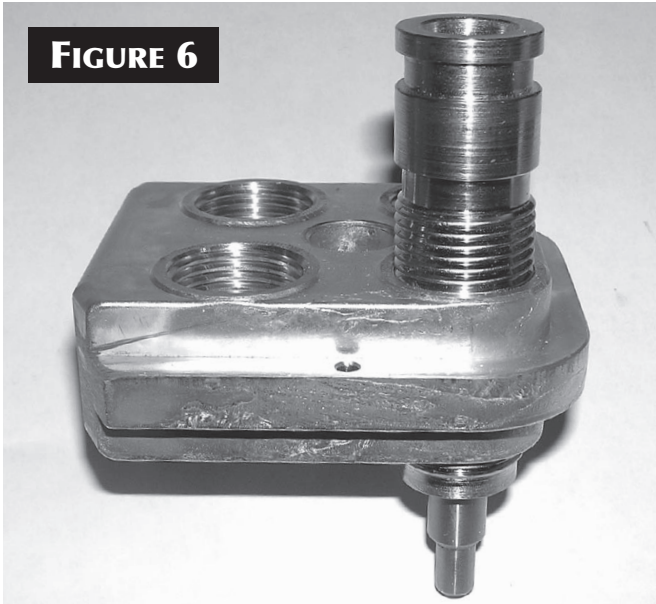

FIGURE 6

[**FIGURE 6**]. Position the toolhead in the frame (be certain to install toolhead pins) and raise the platform up until the small diameter end of the alignment tool goes

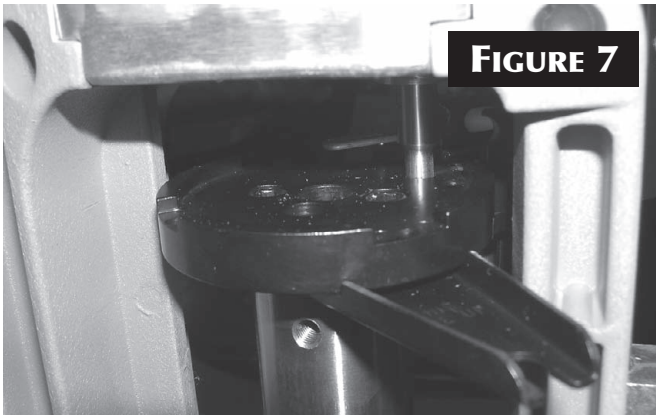

FIGURE 7

freely into the primer punch hole [**FIGURE 7**] you will need to pull the spring-loaded plunger back out of the way. Radial adjustment may be necessary to get the tool

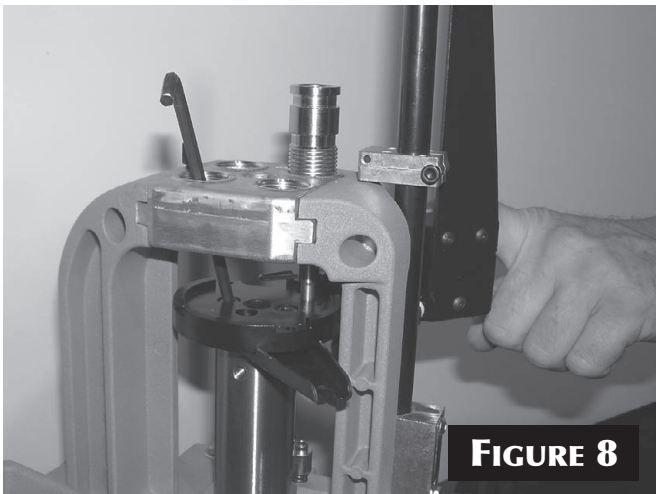

FIGURE 8

to go in and out freely. Once this has been accomplished, +firmly tighten down the two bolts [**FIGURE 8**]. Cycle the operating handle, watching the alignment tool move in and out of the primer punch hole. Make sure the tool goes freely after tightening the screws. You will need to make sure that the lower casefeed assembly that you just

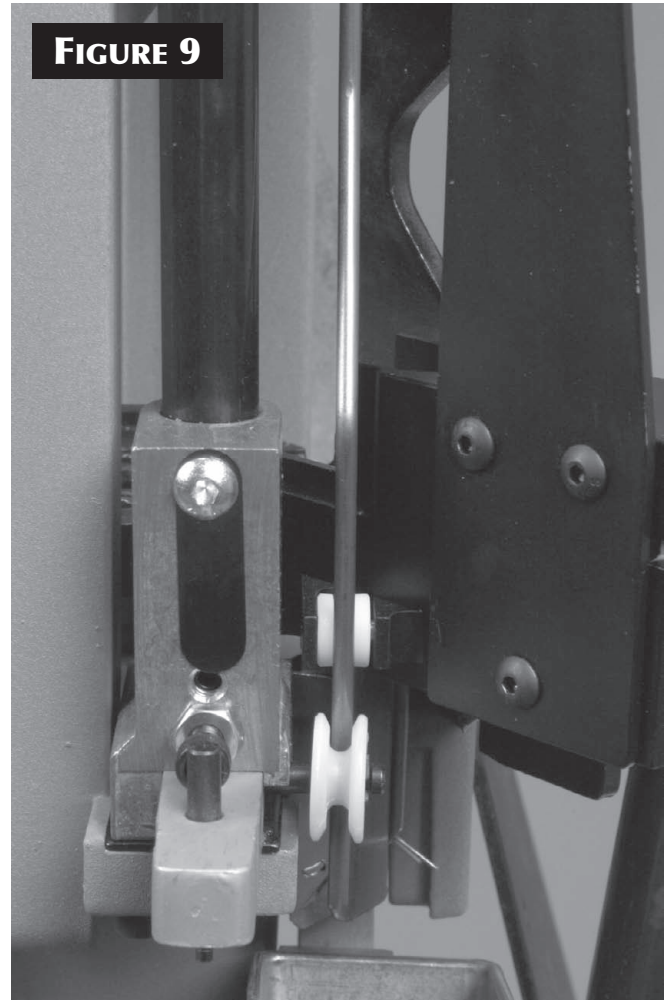

FIGURE 9

installed does not make contact with the primer feed body on the priming stroke [**FIGURE 9**]. If it does, you will need to loosen and rotate the platform counterclockwise and retighten. Remove the toolhead and alignment tool once you are finished.

7. Remove the two rear mounting bolts and the front right mounting bolt holding the machine down to the strong mount or bench.



8. Attach the CF Post Support (part #18907) as shown in [FIGURE 10] with the left rear mounting screw only, finger tight only, do not fully tighten.

9. Align the rear hole in the 550 Casefeed Cam (part #18911) with the right rear mounting hole in the machine frame

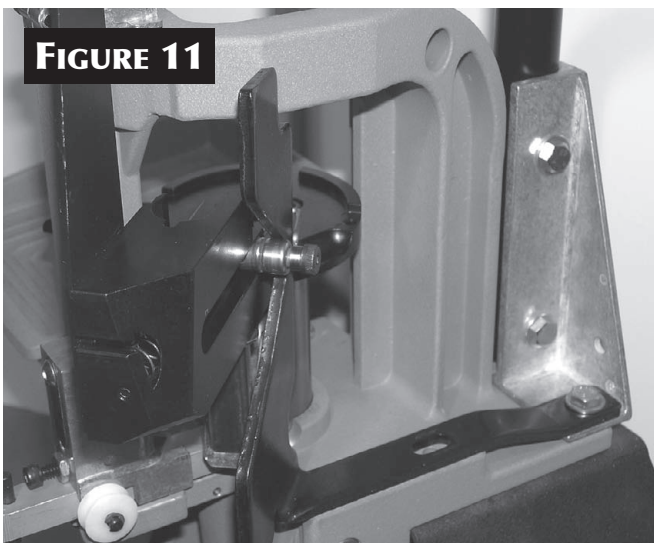

[FIGURE 11] and reinstall the 1/4 -20 bolt with washer and finger tighten the nut. Pull the plunger back and rotate the cam into position so the front mounting hole on the cam aligns with the front mounting hole in frame and reinstall the 1/4 -20 bolt and finger tighten the nut [FIGURE 11]. We recommend that the adjustment be completed without a shellplate on the platform so that the bearing on the plunger will be allowed to bottom out on the housing. Adjustment of the cam is as follows: start with the cam pushed all the way back toward the post support and pull the operating handle down until the roller just reaches the center of the flat on the

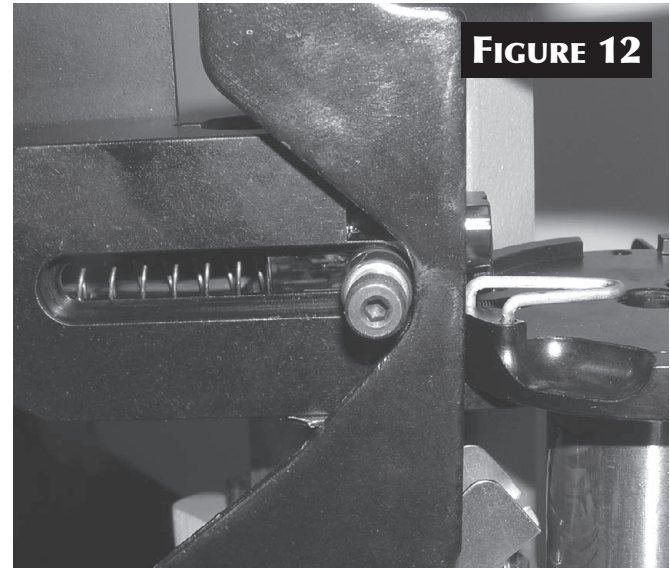

cam [FIGURE 12] (Hint: You can use a powder die to support the platform in position needed for cam adjustment – see [FIGURE 13]). Slide the cam forward until it just barely touches the roller and tighten the two mounting bolts on the cam (be sure not to release the handle until they are tightened). Make sure that the roller on the plunger is centered on the cam and tighten the mounting bolts. Cycle the operating handle a few times and make sure the plunger operates freely.

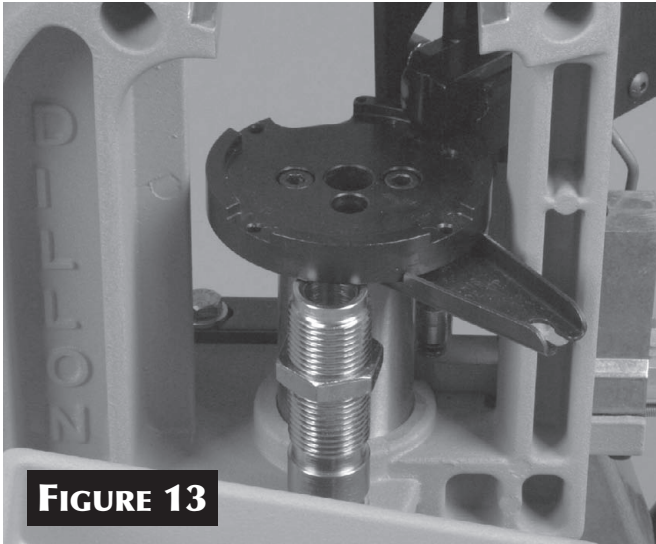

FIGURE 13

10. Tighten the remaining mounting bolts for the post mount to the frame.

11. Re-attach the Primer System Operating Rod [FIGURE 14] and the new Cartridge Chute [FIGURE 15].

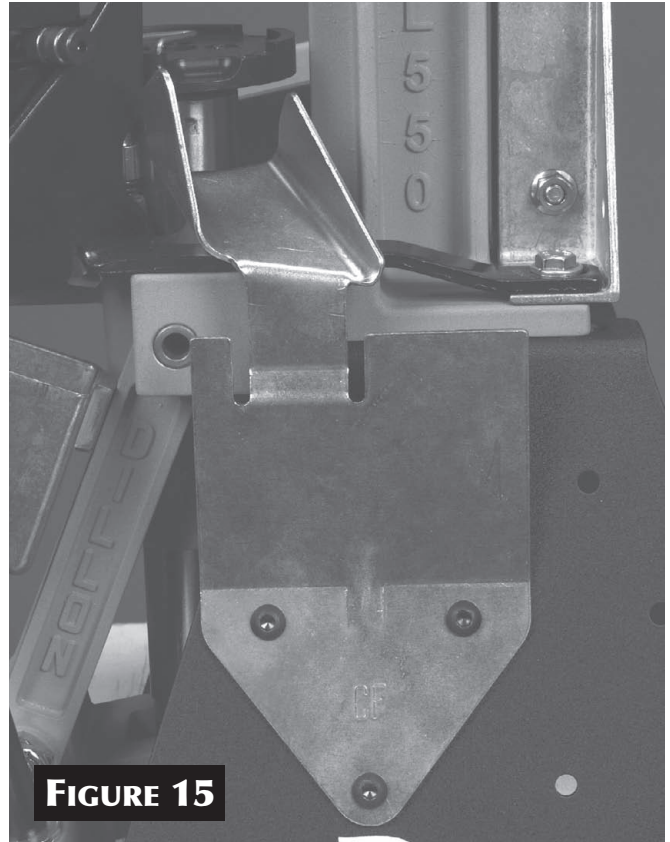

FIGURE 15



FIGURE 14

12. Insert the Post (part #17124) into the 550 CF Post Support (part #18907) (curve of the post needs to go to the right [FIGURE 16]) and fasten with the two 1/4 -20 bolts,



FIGURE 16

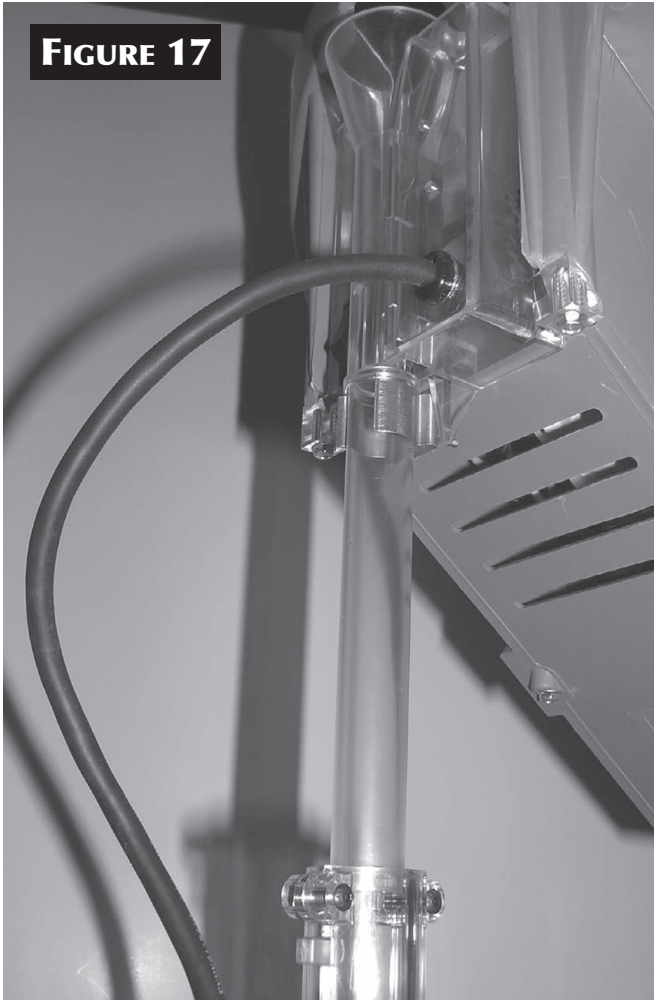

FIGURE 17

washers and nuts that are supplied in the hardware package. The post will have some movement to it once the bolts have been tightened down. Set the 550 CF Upper Bowl Assembly (part #96001) onto the post and using the 1/4 - 20 x 1/2" screw (supplied in the hardware bag) finger tighten the screw against the post. Insert the 550 CF Upper Casefeed Tube (part #18910) into the clip on the casefeed bowl, double check that the flare on the tube is the end that is inserted [FIGURE 17]. Install the casefeed adaptor (from the conversion kit that you separately purchased) into the mounting hole on the 550 CF Lower Feeder Assembly, make sure to align the notch on the adaptor with the corresponding cutout in the housing. Insert the Lower Casefeed Tube (part #18908) into the adaptor and clip the tube into the mounting clip attached to the Lower Feeder Assembly [FIGURE 18].



FIGURE 18

Slide the large end of the micro switch housing over the Upper Casefeed Tube and then slide it down until the Lower Case Feed Tube will insert into the Micro Switch Housing, once installed it should appear as shown in the upper left hand view. Make sure that all of the tubes are in alignment then tighten the screw locking the Upper Casefeed Bowl Assembly to the post.

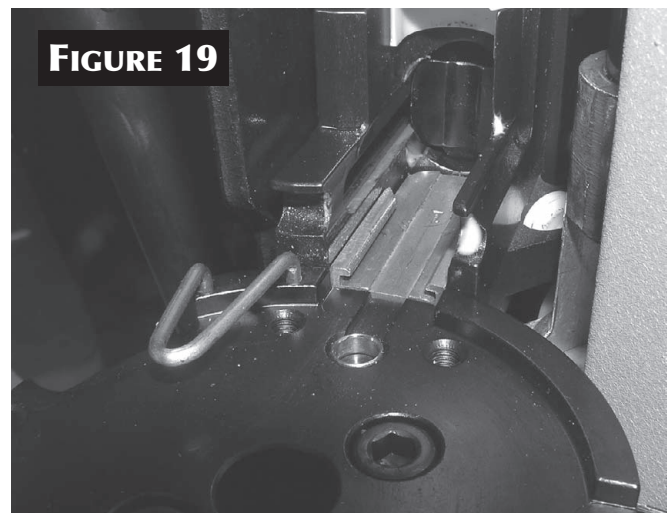
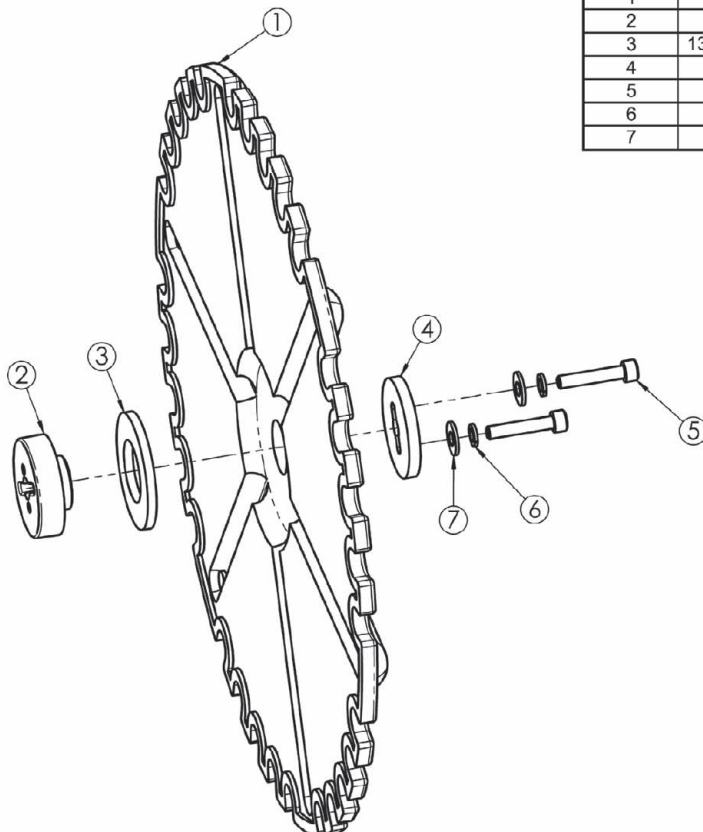

FIGURE 19

13. Once you have the casefeeder setup and before you set the machine up to load a caliber, insert the Station 1 Locator from your conversion kit into the casefeed housing as shown in **FIGURE 19**. Once the Station 1 Locator is installed, setup the machine with the shellplate and die set for the desired caliber you are going to load, don't forget to install the casefeed plate. In the hardware bag is included a large 13/16" washer, this is the spacer for the casefeed plate (please reference attached chart for plate size). If you reference the list supplied it will indicate which calibers require the spacer (see attached view for installation). The clutch on the casefeed plate is factory pre-set at 5 in/lbs of torque, this will allow the plate to slip if it should become jammed. Over

tightening the clutch will not let it operate correctly and can cause motor failure. We recommend that you fill the casefeeder with two scoops of shells with the 550 cartridge bin so as not to over fill the casefeed bowl. When you are ready to load if you pull the operating handle to the down position (before you turn on the casefeeder) it will make certain that the first case that drops does not have the possibility of falling over. After there are at least 5-6 cases in the tube you can release the operating handle. If you begin to experience a problem with the case not feeding into the shellplate, die or the case is bouncing out of the shellplate then you will need to refer to the troubleshooting section for fine adjustment procedures for the cam.

Exploded View, Casefeed Plate Assembly



PARTS LIST		
ITEM #	DESCRIPTION	QTY.
1	CASEFEED PLATE	1
2	13736 LOWER CLUTCH	1
3	13703 13/16 WASHER (SUPPLIED IN HARDWARE KIT)	1
4	13632 UPPER CLUTCH	1
5	13732 10-32 x 1 CLUTCH SCREWS	2
6	13813 #10 LOCK WASHER	2
7	13738 #10 STAINLESS FLAT WASHER	2

Exploded View, CF Lower Feeder Assembly

ITEM #	PART #	DESCRIPTION	QTY.
1	18904	550 CF BODY	1
2	18906	550 CF PLUNGER SPRING	1
3	18905	550 CF PLUNGER	1
4	18920	550 CF BEARING	2
5	18921	550 1/4 x 7/8 SHOULDER BOLT	1
6	18902	550 CF TUBE SUPPORT	1
7	13859	CF TUBE CLIP	1
8	18918	4-40 x 3/8 BHCS	1
9	14038	4-40 KEPSNUT	1
10	18912	8-32 x 5/16 BHCS	3
11	18913	1/8 x 1/4 ROLL PIN	1
12	13823	8-32 x 3/16 SHSC	1
13	18914	1/4 x 7/8 DOWELL PIN	1
14	13765	550 ROLLER	1
15	18912	8-32 x 5/16 BHCS	2
16	14457	8-32 x 1/2 SOCKET FLAT HEAD	2
17	18917	SPENT PRIMER CHUTE BRACKET	1
18	13899	PRIMER CATCHER CHUTE	1
19	13998	COTTER KEY	1

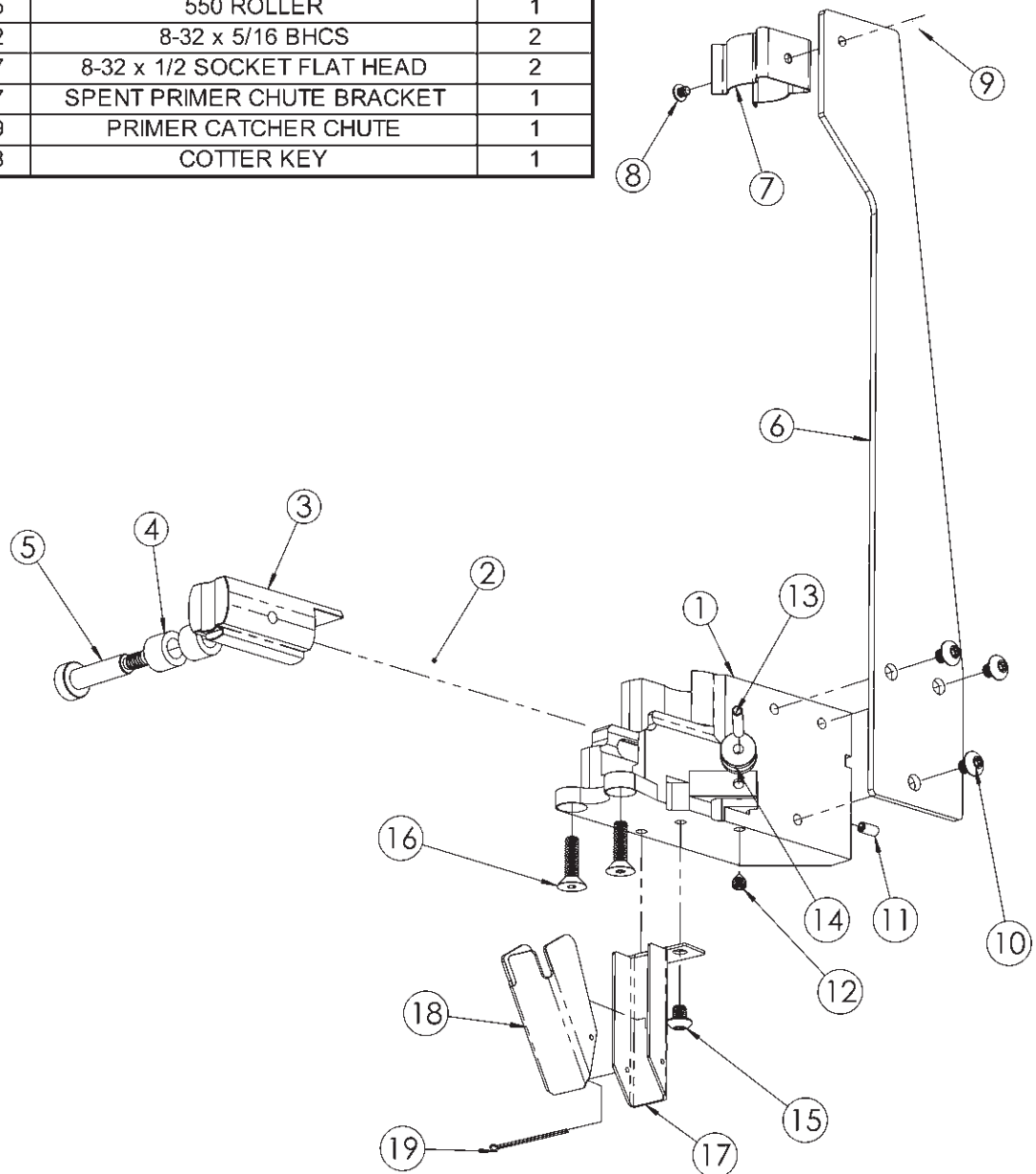

Troubleshooting and Helpful Hints

- **Fine Adjustment of Cam:** If you are experiencing a problem with the case not feeding all of the way into the shellplate (and/or sizing die) or bouncing back out of the shellplate, you will need to fine adjust the cam for each and every caliber that you are loading. You will want to start with a case from the caliber you are preparing to load in the first station of the shellplate. In the following procedure you will practically repeat the steps for setting up the cam on initial installation with the exception of letting the plunger rest on the case in the shellplate instead of the housing. Pull the operating handle down until roller on casefeed plunger reaches about the center of the flat on the cam and the plunger is resting on the case in the shellplate. Loosen the cam and slide it in or out until it is just barely touching the roller, then re-tighten the mounting bolts on the cam, be sure not to release the handle until tightened. Once you have finished loading the caliber that you have fine-tuned the cam for, you will want to return it to its original position by repeating the setup steps in Note 9 [FIGURE 20].

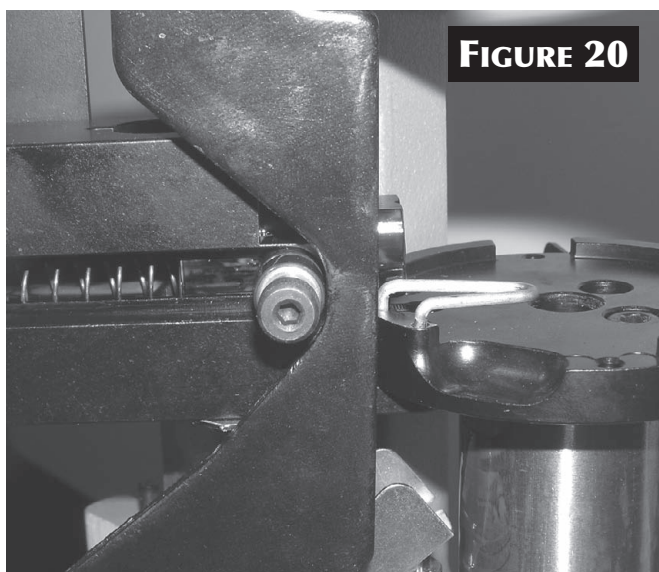

FIGURE 20

- If you are having trouble with the case sliding through or sticking in the Station 1 locator make sure there are no burrs on the

inside edges of the tracks or that they have not been bent or crushed.

- If you are experiencing a sticky action with the plunger you may have tumbling media or other debris that is causing the plunger to stick or bind. You will have to remove the shellplate, shellplate bolt, indexing star and the Station 1 locator so you can remove the plunger from the casefeed body. To remove the plunger it will be easier to pull the operating handle down so the roller is on flat in the center of the cam to reduce spring tension. Slowly remove the shoulder bolt and two bearings. The spring will want to push the plunger out of the body, once the bolt is out remove the plunger and spring from the body. Use a clean rag to wipe off the plunger and the inside of the housing. Re-lube the plunger and housing with MIL-COMM TW-25B (part #15732) grease or equivalent. You can also re-lube the bearing assembly at this time. Re-insert spring into plunger and slide assembly into housing making sure spring is held down by the pin at end of housing. Install bearing assembly and tighten. At this time also lube the channel that the bearing rides in on the housing with the same grease.

- If you have double feed, it will be easiest to clear out the lower feed tube and remove the casefeed adaptor so you can pull the plunger all the way back and remove the cases.

- If you are having trouble with the case lining up or jamming in the sizing die mouth, make sure you are using a sizing die with a radiused entry on the mouth. We recommend that a Dillon Sizing Die be used – Dillon dies have radiused mouths that allow the case to enter the die easier.

- If you need further assistance please call: 1-800-223-4570

Dillon RL 550B

Caliber Conversions

CONV. PART #	CALIBER	STATION 1 LOCATOR	CASEFEED ADAPTOR
14206	.25-20 WIN	W (14225)	BLUE (13075)
14284	.30 LUGER	5 (14224)	GREEN (13450)
14204	.30 MAUSER	5 (14224)	RED (13143)
14205	.32 S&W LONG	D (14223)	GREEN (13450)
14283	.32 H&R MAG	D (14223)	BLUE (13075)
14206	.32-20 WIN	W (14225)	BLUE (13075)
14284	9 MM / 9x21 / .38 SUPER	5 (14224)	GREEN (13450)
14285	9x25 DILLON	W (14225)	RED (13143)
14287	.38 SUPER COMP.	3 (14227)	GREEN (13450)
14208	.38 S&W	2 (14226)	PURPLE (18076)
14286	.38 SPL.	2 (14226)	ORANGE (13386)
14289	.357 SIG	W (14225)	PURPLE (18076)
14286	.357 MAG	2 (14226)	ORANGE (13386)
14288	.38-40 WIN	N (14228)	YELLOW (13442)
14292	.40 SUPER	1 (14231)	RED (13143)
14292	.400 COR-BON	1 (14231)	RED (13143)
14289	.40 S&W	W (14225)	PURPLE (18076)
14285	10 MM	W (14225)	RED (13143)
14290	.41 MAG.	6 (14229)	YELLOW (13442)
14288	.44-40 WIN	N (14228)	YELLOW (13442)
14291	.44 COLT	4 (14230)	YELLOW (13442)
14209	.44 RUSSIAN	4 (14230)	RED (13143)
14291	.44 SPL. / 44 MAG.	4 (14230)	YELLOW (13442)
11441	.45 GAP	1 (14231)	GRAY (12670)
14292	.45 ACP	1 (14231)	RED (13143)
19140	.45 AUTO RIM	UNIVERSAL (19139)	RED (13143)
14279	.45 S&W SCHOFIELD	C (14232)	YELLOW (13442)
14279	.45 COLT	C (14232)	YELLOW (13442)
14210	.45 WIN MAG.	1 (14231)	YELLOW (13442)
14279	.454 CASULL	C (14232)	YELLOW (13442)

**** CONVERSION PART NUMBERS ONLY CONTAIN THE STATION 1 LOCATOR AND THE CASEFEED ADAPTOR ****

550 CASEFEED WILL NOT WORK ON RIFLE CALIBERS, INCLUDING 30 CARBINE & 22 HORNET

550 CASEFEED STATION 1 LOCATORS ARE NOT THE SAME AS 650 STATION 1 LOCATORS

Casefeeder Calibers

Additional Caliber Components

SHELLPLATE	LOCATOR PIN	POWDER FUNNEL	CASEFEED PLATE	SPACER
O (12013)	3 (14060)	R (13243)	SP (21073)	
5 (13743)	3 (14060)	C (13564)	SP (21073)	
5 (13743)	3 (14060)	C (13564)	SP (21073)	
D (13092)	3 (14060)	SW (13171)	SP (21073)	
D (13092)	3 (14060)	SW (13171)	SP (21073)	
O (12013)	3 (14060)	S (12845)	SP (21073)	
5 (13743)	3 (14060)	F (13806)	SP (21073)	
5 (13743)	2 (14062)	F (13806)	LP (21072)	
3 (13334)	3 (14060)	F (13806)	SP (21073)	
U (12944)	2 (14062)	F (13806)	LP (21072)	
2 (13751)	2 (14062)	D (13599)	LP (21072)	X
5 (13743)	2 (14062)	F (13806)	LP (21072)	
2 (13751)	2 (14062)	D (13599)	LP (21072)	X
N (10004)	4 (14047)	W (13600)	LP (21072)	X
1 (13692)	1 (13930)	W (13600)	LP (21072)	
1 (13692)	1 (13930)	W (13600)	LP (21072)	
5 (13743)	2 (14062)	W (13600)	LP (21072)	
5 (13743)	2 (14062)	W (13600)	LP (21072)	
6 (13120)	1 (13930)	H (13240)	LP (21072)	X
N (10004)	4 (14047)	4 (13474)	LP (21072)	X
4 (13610)	1 (13930)	G (13427)	LP (21072)	
4 (13610)	1 (13930)	G (13427)	LP (21072)	
4 (13610)	4 (14047)	G (13427)	LP (21072)	X
1 (13692)	1 (13930)	E (13782)	LP (21072)	
1 (13692)	1 (13930)	E (13782)	LP (21072)	
H (13010)	4 (14047)	E (13782)	LP (21072)	
C (13334)	4 (14047)	E (13782)	LP (21072)	
C (13334)	4 (14047)	E (13782)	LP (21072)	X
L (12703)	1 (13930)	E (13782)	LP (21072)	
C (13334)	4 (14047)	E (13782)	LP (21072)	X

'Belted Magnum' Powder System

Magnum rifle cartridges can require from 70 grains to well in excess of 100 grains for a single charge. Our new "Belted Magnum" Powder System features a new, maximum-capacity, steel powder bar that can dispense more than 100 grains of extruded IMR powder.

Our magnum powder system can be used with your RL 550B, XL 650 or AT 500 reloader, and is ideal for loading large-caliber, magnum rifle cartridges. We tested this system with various extruded rifle powders and found that powder charge variations stayed within plus-or-minus three-tenths of a grain.

The "Belted Magnum" Powder System is



based on our SL 900 Shot Dispenser, so the Maximum Charge Bar won't work in our standard powder measures – you'll need to buy the entire system. The good news is that the "Belted Magnum" Powder System has an integral drain, so it's easy to empty the hopper in order to change powder types; so, if you load several big calibers with various powders, it's easy to switch from one to another.

Keep plenty of extra powder on hand, because when you're dispensing 100-plus grains into every cartridge, you're gonna need it!

Magnum Powder System
Stock #97126

Strong Mount

Increase the stability of your reloading bench with Dillon's new Strong Mounts. These heavy gauge steel Strong Mounts increase the machine's "footprint" to over 10", spreading the load over the whole bench instead of stressing the leading edge.

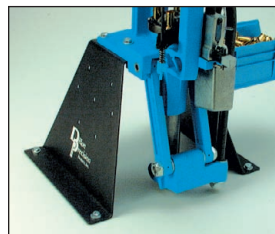

Strong Mounts raise your machine 6" to 8", providing a comfortable work height for people who prefer to stand while reloading. For some XL 650 owners, overhead clearance can become a problem, so we designed a mount especially for this application. The XL 650-only mount raises the machine 6" above the bench top. All mounts come with all the fasteners necessary to mount your machine (550/650 mount includes RL 550B bin bracket) and are coated with a durable black wrinkle finish.

RL550/XL650 Strong Mount Stock #22051

Bullet Tray Kit

Dillon's original RL 1000 came equipped with a simple, shallow aluminum bullet tray that was designed for economy of motion when loading. For years, our attempts to duplicate the efficiency and the "feel" of that tray in other machine applications were less than satisfactory. It took the development of the Strong Mount for the RL 550 and the XL 650 to enable us to place the redesigned tray exactly where it needed to be.



Our aluminum tray works on the Square Deal 'B', the RL 550B and XL 650 when equipped with the RL 550/XL 650 Strong Mount, and a separate kit is available for the RL 1050. Comes with a Dillon Blue powder coat finish.

Bullet Tray Kit Stock #22214

Dust Covers

Toolhead Cover (L) for use **without** powder measure.
Stock #11142

Quick-Change Cover (R) for use **with** powder measure.
Stock #11143



Bench Wrench

1" die lock rings and a 1" wrench to fit them gives you much more room to re-adjust your dies after they're already mounted in the toolhead.



5-Pack of Die Lock Rings Stock #10669

1" Dillon Bench Wrench Stock #10842

On the cover...

The RL 550B is pictured with optional accessories:

Strong Mount	#22051
Low Powder Sensor	#16306
Bullet Tray	#22214

Other accessories available for the RL 550B include:

Video Instruction Manual	#14621
Machine Cover	#13795
Maintenance Kit & Spare Parts Kit	#97016

The **Blue Press**, Dillon's monthly catalog, has a complete listing of accessories available for all machines.

Dillon Precision Products, Inc.

8009 E. Dillon's Way

Scottsdale, AZ 85260

(480) 948-8009

FAX (480) 998-2786

Web Site: www.dillonprecision.com

Technical Support E-mail: dillon@dillonprecision.com

See our Troubleshooting Section online at www.dillonprecision.com

Technical Support & Customer Service

(800) 223-4570

