

  
**KOZY HEAT**  
FIREPLACES

*Quality Fireplaces for Life*

**Models: #CSK-31**  
**#CSK-31-RF**

**CHASKA**

**DIRECT VENT FIREPLACE INSERT**

**WARNING:** This product must be installed by a licensed plumber or gas fitter when installed in the Commonwealth of Massachusetts.

**IMPORTANT:** Installation of a CO detector is required in the fireplace room when installed in the Commonwealth of Massachusetts.

This appliance may be installed in an aftermarket permanently located, manufactured (mobile) home, where not prohibited by local codes.

A manufactured home (USA only) or mobile home OEM installation must conform with the *Manufactured Home Construction and Safety Standard, Title 24 CFR, Part 3280*, or when such a standard is not applicable, the *Standard for Manufactured Home Installations, ANSI/NCSBCS A225.1*, or *Standard for Gas Equipped Recreational Vehicles and Mobile Housing, CSA Z240.4*

**WARNING:** If the information in these instructions are not followed exactly, a fire or explosion may result, causing property damage, personal injury or loss of life.

- ❑ Do not store or use gasoline or other flammable vapors and liquids in the vicinity of this or any other appliance.

**IF YOU SMELL GAS:**

- ❑ Do not light any appliance.
- ❑ Do not touch any electrical switch: do not use any phone in your building.
- ❑ Immediately call gas supplier from a neighbors phone. Follow the gas supplier instructions.
- ❑ If you cannot reach your gas supplier, call the fire department.
- ❑ Installation and service must be performed by a qualified installer, service agency or the gas supplier.

This appliance is only for use with the type (s) of gas indicated on the rating plate. A conversion kit is supplied with the appliance.

Tested &  
Listed By



Portland  
Oregon USA

OMNI-Test Laboratories, Inc.

[www.kozyheat.com](http://www.kozyheat.com)

**INSTALLATION  
AND  
OPERATION MANUAL**

**INSTALLER: LEAVE THIS MANUAL WITH THE APPLIANCE.**

**CONSUMER: RETAIN THIS MANUAL FOR FUTURE REFERENCE.**

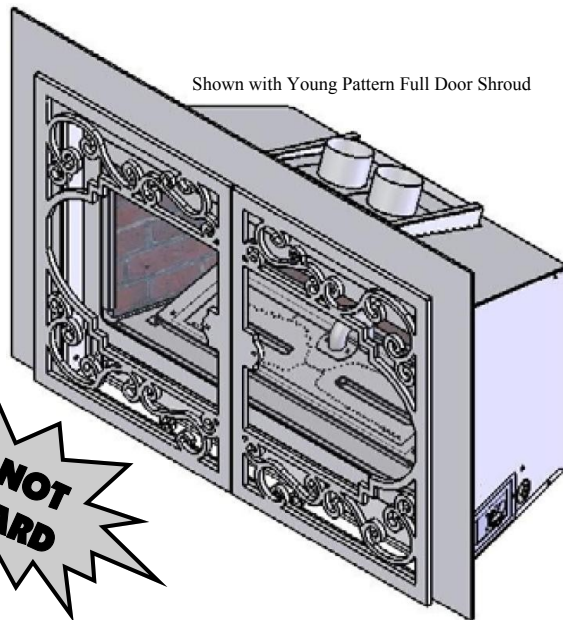

Shown with Young Pattern Full Door Shroud



We recommend that our gas hearth products be installed and serviced by professionals who are certified in the U.S. by the National Fireplace Institute® (NFI) as NFI Gas Specialists.

May - 2009  
CSK-31-REV-08

# INTRODUCTION

**Read this manual before installing or operating this appliance.  
Please retain this owner's manual for future reference.**

## CONGRATULATIONS!

*We welcome you as a new owner of a Kozy Heat gas fireplace. Kozy Heat products are designed with superior components and materials and assembled by trained craftsmen who take pride in their work. The burner and valve assembly are 100% test-fired and the complete fireplace is thoroughly inspected before packaging to ensure that you receive a quality product. Our commitment to quality and customer satisfaction have remained the same for over 30 years. We offer a complete line of gas and wood fireplaces, unique cabinets and stylish accessories to compliment any décor. Adding a fireplace is one of the best ways to increase the value of your home and we are proud to offer a network of dealers throughout the country to help make your experience everything you imagine. We pride ourselves in being dedicated to not only function and reliability, but customer safety as well. We offer our continual support and guidance to help you achieve the maximum benefit and enjoyment from your Kozy Heat gas fireplace.*



Jim Hussong  
President



Dudley Hussong  
Board Chairman

### Homeowner Reference Information

*We recommend that you record the following information about your fireplace.*

Model Name: \_\_\_\_\_ Date purchased/installed: \_\_\_\_\_

Serial Number: \_\_\_\_\_ Location on fireplace: \_\_\_\_\_

Dealership purchased from: \_\_\_\_\_ Dealer Phone: \_\_\_\_\_

Notes: \_\_\_\_\_

\_\_\_\_\_  
\_\_\_\_\_

# TABLE OF CONTENTS

<b><u>INTRODUCTION</u></b>	
Introduction and Homeowner Reference Information	1
<b><u>CONTENTS</u></b>	
Table of Contents	2
<b><u>SAFETY INFORMATION</u></b>	
Safety Information	3
<b><u>FEATURES</u></b>	
Features	4
<b><u>COMMONWEALTH OF MASSACHUSETTS INFORMATION</u></b>	
Commonwealth of Massachusetts Information	5
<b><u>SPECIFICATIONS</u></b>	
Fireplace Dimensions	6
Clearances	6
Components List	7
Additional Components Required	7
Placement Clearance Requirements	7
<b><u>EXISTING FIREPLACE SPECIFICATIONS</u></b>	
Existing Fireplace Requirements	8
<b><u>PREPARE EXISTING FIREPLACE</u></b>	
Existing Fireplace Minimum Opening Requirements	9
Prepare Existing Fireplace	9
<b><u>FAN DIRECT WIRE INSTALLATION</u></b>	
CSK-31 Fan Direct Wire Installation	10
CSK-31-RF Fan Direct Wire Installation	11
<b><u>THERMOSTAT / WALL SWITCH / REMOTE - CSK-31</u></b>	
Thermostat / Wall Switch / Remote - CSK-31	12
<b><u>GLASS FRAME ASSEMBLY</u></b>	
Glass Frame Assembly Removal	13
Glass Frame Assembly Installation	13
<b><u>INSTALLATION</u></b>	
Approved Venting	14
Combustion Air Venting Options	14
Air Duct Removal	14
Kozy Heat #816-CL Co-Linear Vent System	15
Run Vent System Through Existing Chimney	16
Connect Vent System to Air Duct	17
Position Fireplace Insert	17

<b><u>GAS LINE CONNECTION</u></b>	
Gas Line Connection	18
Check Millivolt Board Installation	18
<b><u>COMPLETE FAN WIRING INSTALLATION</u></b>	
CSK-31 Complete Fan Wiring Installation	19
CSK-31-RF Complete Fan Wiring Installation	19
<b><u>3 PIECE SHROUD ASSEMBLY AND INSTALLATION</u></b>	
3 Piece Shroud Assembly and Installation	20
<b><u>LOG SET INSTALLATION</u></b>	
Log Set Installation	21
<b><u>MILLIVOLT BOARD REMOVAL</u></b>	
Millivolt Board Removal	22
<b><u>MILLIVOLT BOARD INSTALLATION</u></b>	
Millivolt Board Installation	23
<b><u>CSK-31 OPERATING INSTRUCTIONS</u></b>	
CSK-31 Valve and Pilot Assembly Components	24
CSK-31 Lighting and Shutdown Instructions	25-27
CSK-31 Pressure Testing	28
<b><u>CSK-31-RF OPERATING INSTRUCTIONS</u></b>	
CSK-31-RF Valve and Pilot Assembly Components	29
CSK-31-RF Lighting and Shutdown Instructions	30-32
CSK-31-RF Pressure Testing	33
CSK-31-RF Remote Receiver Functions	34-35
<b><u>FINALIZING THE INSTALLATION</u></b>	
Flame Appearance	36
To Adjust Venturi	36
<b><u>MAINTENANCE</u></b>	
Maintenance	37
<b><u>TROUBLESHOOTING (CSK-31)</u></b>	
Troubleshooting (CSK-31)	38-40
<b><u>TROUBLESHOOTING (CSK-31-RF)</u></b>	
RF Remote Troubleshooting (CSK-31-RF)	41
Troubleshooting (CSK-31-RF)	42-43
<b><u>REPLACEMENT PARTS LIST</u></b>	
Replacement Parts List	44
<b><u>WARRANTY</u></b>	
Warranty	45-46

# SAFETY INFORMATION

This fireplace has been tested to and complies with ANSI Z21.88a-2007-CSA 2.33a-2007-CSA P.4.1-02 "VENTED GAS FIREPLACE HEATERS" by OMNI-Test Laboratories, Portland, OR. Installation must conform with local building codes or in the absence of local building codes, with the National Fuel Gas Code, ANSIZ223.1/NFPA 54 - Current Edition, or the Natural or Propane Installation Code, CSAB149.1

- Installation and repair should be done only by a qualified service person. The appliance should be inspected by a qualified service person before use. Annual inspection by a qualified service person is required to maintain warranty. More frequent cleaning may be required due to excessive lint from carpeting, bedding materials, etc. It is imperative that control compartments, burners and circulation air passageways of the appliance be kept clean.
- If this appliance is installed directly on carpeting, tile or other combustible material other than wood flooring, the appliance shall be installed on a metal or wood panel extending the full width and depth of the appliance.
- Children and adults should be alerted to the hazards of high surface temperatures and should stay away to avoid burns or clothing ignition.
- Young children should be carefully supervised when they are in the same room as the appliance.
- Clothing or other flammable material should not be placed on or near the appliance.
- Adequate accessibility clearances for servicing and proper operation must be maintained.
- This appliance must not share or be connected to a chimney flue serving any other appliance.
- Keep area around the appliance clear of combustible materials, gasoline and other flammable vapor and liquids.
- The flow of combustion and ventilation air must not be obstructed.
- Due to high temperatures the appliance should be located out of traffic and away from furniture and draperies.
- The glass front or any part removed for servicing the appliance must be replaced prior to operating the appliance. Work should be done by a qualified service technician.
- Clean glass only when cool and only with non-abrasive cleansers.
- Do not operate this appliance with the glass/frame assembly removed, cracked or broken. The glass assembly, Part #CSK-057T, shall only be replaced as a complete unit, as supplied by Hussong Mfg. Co., Inc. Replacement of the glass assembly must only be performed by a licensed or qualified service person. DO NOT SUBSTITUTE MATERIALS.
- Do not strike or slam glass assembly.
- Any safety screen or guard removed for servicing the appliance must be replaced prior to operating the appliance.
- Under no circumstances should any solid fuel (wood, coal, paper or cardboard etc.) be used in this appliance.
- Keep burner and control compartment clean.
- Do not use this fireplace if any part has been under water. Immediately call a qualified service technician to inspect this appliance and to replace any part of the control system and any gas control which has been under water.

# FEATURES

## STANDARD FEATURES

- High efficiency
- High quality lifetime glass  
14-1/4" x 29" (362 mm x 737 mm)
- Quick latch glass frame assembly
- Co-linear vent system - 3" combustion air / 3" exhaust
- Innovative vent connection system
- Engineer-designed burner system
- High - Low regulator
- Modulating valve system w/ fan and flame adjustment, remote control (Kozy Kontrol)\*
- Automatic fan kit (2) - 75 CFM
- Refractory brick lining
- (2) hoods / lower grill (black)
- Minnesota Energy Code compliant to 50 pascals

\*Standard on RF models

## SAFETY FEATURES

- **Each unit factory tested!**
- Tested by OMNI - Test Laboratories
- Sealed combustion chamber with standing pilot ignition
- Removable millivolt board with 30-second delay pilot
- Automatic pressure relief glass system
- Requires no electricity to operate (excluding fan)
- Bedroom and mobile home approved

## WEIGHT

- Fireplace Weight (as packaged for shipment)  
127 lbs. (57.61 kg)

## OPTIONAL FEATURES

- Red brick refractory
- Standard size or custom sized (3 & 4 pc.) shrouds
- Surrounds
- Flex vent adaptor kit
- Remote control\* or thermostat remote control
- Wall mount thermostat / wireless wall mount thermostat
- Decorative full door faces in various styles and finishes
- Mission design doors in various finishes
- Various cabinet & flush surrounds

\*Standard on RF models

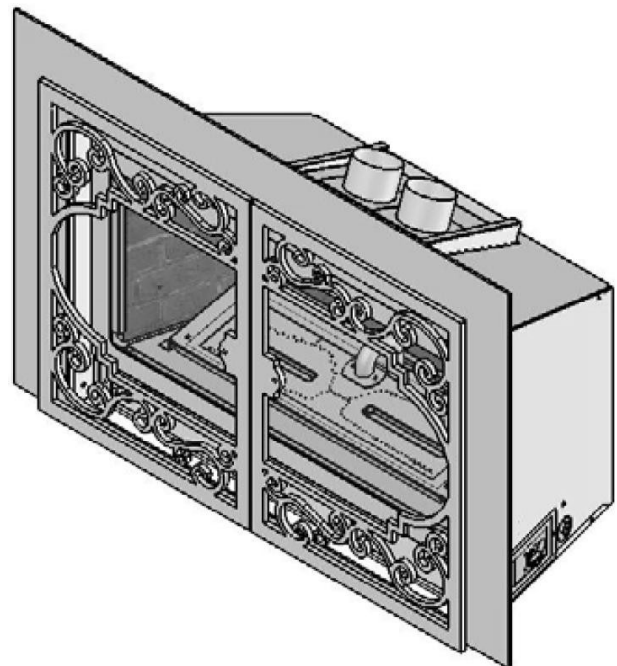

# COMMONWEALTH OF MASSACHUSETTS REQUIREMENTS



**NOTE: The following requirements reference various Massachusetts and national codes not contained in this manual.**

For all sidewall horizontally vented gas fueled equipment installed in every dwelling, building or structure used in whole or in part for residential purposes, including those owned or operated by the Commonwealth and where the side wall exhaust vent termination is less than (7) feet above finished grade in the area of the venting, including but not limited to decks and porches, the following requirements shall be satisfied:

## INSTALLATION OF CARBON MONOXIDE DETECTORS

At the time of installation of the side wall horizontally vented gas fueled equipment, the installing plumber or gas-fitter shall observe that a hard wired carbon monoxide detector with an alarm and battery back-up is installed on the floor level where the gas equipment is to be installed. In addition, the installing plumber or gas-fitter shall observe that a battery operated or hard wired carbon monoxide detector is installed on each additional level of the dwelling, building or structure served by the side wall horizontal vented gas fueled equipment. It shall be the responsibility of the property owner to secure the services of qualified licensed professionals for the installation of hard wired carbon monoxide detectors.

In the event that the side wall horizontally vented gas fueled equipment is installed in a crawl space or attic, the hard wired carbon monoxide detector with alarm and battery back-up may be installed on the next adjacent floor level.

In the event that the requirements of this subdivision can not be met at the time of completion of installation, the owner shall have a period of thirty (30) days to comply with the above requirements; provided, however, that during said thirty (30) day period, a battery operated carbon monoxide detector with an alarm shall be installed.

## APPROVED CARBON MONOXIDE DETECTORS

Each carbon monoxide detector as required in accordance with the above provisions shall comply with NFPA 720 and be ANSI/UL 2034 listed and IAS certified.

## SIGNAGE

A metal or plastic identification plate shall be permanently mounted to the exterior of the building at a minimum of eight (8) feet above grade directly in line with the exhaust vent terminal for the horizontally vented gas fueled heating appliance or equipment. The sign shall read, in print no less the one-half inch (1/2") in size, **"GAS VENT DIRECTLY BELOW. KEEP CLEAR OF ALL OBSTRUCTIONS"**.

## INSPECTION

The state or local gas inspector of the side wall horizontally vented gas fueled equipment shall not approve the installation unless, upon inspection, the inspector observes carbon monoxide detectors and signage installed in accordance with the provisions of 248 CMR 5.08 (2) (a) 1 through 4.

## EXEMPTIONS

The following equipment is exempt from 248 CMR 5.08 (2) (a) 1 through 4: The equipment listed in Chapter 10 entitled "Equipment Not Required To Be Vented" in the most current edition of NFPA 54 as adopted by the Board; and Product Approved side wall horizontally vented gas fueled equipment installed in a room or structure separate from the dwelling, building or structure used in whole or in part for residential purposes.

## MANUFACTURER REQUIREMENTS - GAS EQUIPMENT VENTING SYSTEM PROVIDED

When the manufacturer of Product Approved side wall horizontally vented gas equipment provides a venting system design or venting system components with the equipment, the instructions provided by the manufacturer for installation of the equipment and the venting system shall include:

Detailed instructions for the installation of the venting system design or the venting system components; and

A complete parts list for the venting system design or venting system.

## MANUFACTURER REQUIREMENTS - GAS EQUIPMENT VENTING SYSTEM NOT PROVIDED

When the manufacturer of Product Approved side wall horizontally vented gas equipment does not provide the parts for venting the flue gases, but identifies "special venting systems", the following requirements shall be satisfied by the manufacturer:

The referenced "special venting systems" instructions shall be included with the appliance or equipment installation instructions and;

The "special venting systems" shall be Product Approved by the Board, and the instructions for that system shall include a parts list and detailed installation instructions.

A copy of all installation instructions for all Product Approved side wall horizontally vented gas fueled equipment, all venting instructions, all parts lists for venting instructions, and/or all venting design instructions shall remain with the appliance or equipment at the completion of the installation.

# SPECIFICATIONS

## FIREPLACE DIMENSIONS

	LETTER KEY	A	B	C	D	E	F	G	H	I
	DESCRIPTION	Height	Width	Back Width	Depth	Back Height	Back to Elec. Access	Back to Gas Line Access	Front to Vent Center	Back to Vent Center
FIREPLACE DIMENSIONS	INCHES	19-1/4	30-7/8	23-1/8	14-1/2	14-5/8	9-1/8	4-7/8	9-14	5-1/2
	MILLIMETERS	489	784	587	368	371	232	124	235	140

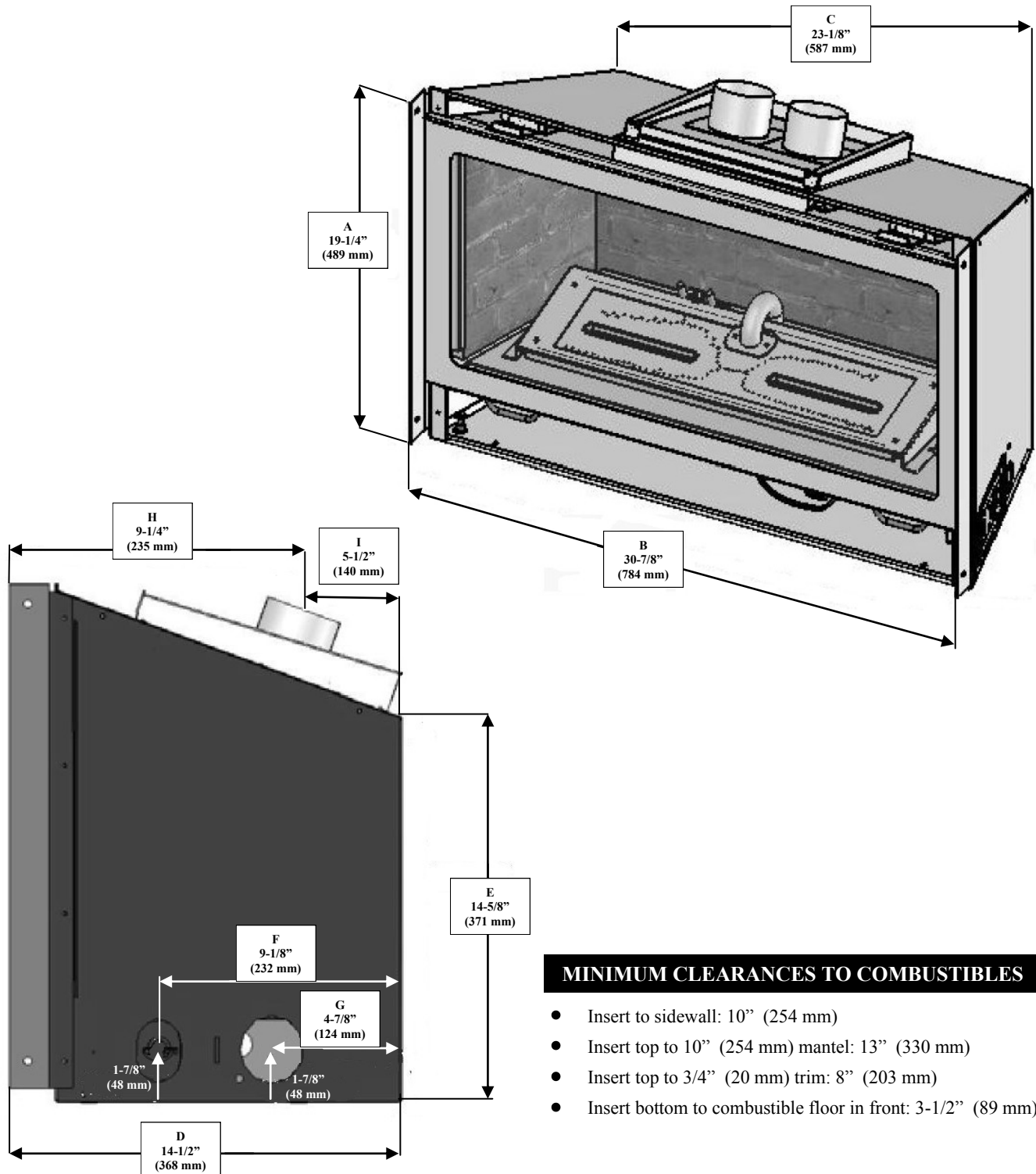

# SPECIFICATIONS

## MODEL #CSK-31 COMPONENTS LIST

- (#CSK-800) - Millivolt Board Assembly with 18" Flexible Gas Line attached
- (#700-203) - Manual Gas Shut-off Valve
- (#CSK-135) - Burner Assembly
- (#CSK-G900) - Refractory Set
- (#CSK-50A) - Log Package
- (#CSK-057T) - Glass Frame Assembly
- (#OCK-H52L) - LP Conversion Kit
- (#816-CL1) - Co-Linear Air Duct
- (#CSK-028) - Fan Kit (2)-75 CFM
- (#500-CSK) - Grill Assembly

## MODEL #CSK-31-RF COMPONENTS

- (#CSK-800-RF) - Millivolt Board Assembly with 18" Flexible Gas Line attached
- (#700-203) - Manual Gas Shut-off Valve
- (#CSK-135) - Burner Assembly
- (#CSK-G900) - Refractory Set
- (#CSK-50A) - Log Package
- (#RF-028) - RF Fan Kit
- (#CSK-057T) - Glass Frame Assembly
- (#OCK-H52L-RF) - LP Conversion Kit
- (#700-108) - Remote Control
- (#816-CL1) - Co-Linear Air Chute
- (#500-CSK) - Grill Assembly

## ADDITIONAL COMPONENTS REQUIRED

**Vent System;** Part #816-CL: For use with minimum 6" x 8" I.D. masonry or 7" I.D. Class A metal chimneys - Includes 12 ft. (3.66 m) compressed, expandable to 35 ft (10.67 m) co-linear 3" x 3" flexible chimney, and termination cap.

**Other approved venting:** ICC, Selkirk, American Metals, Simpson Dura-Vent

**Shrouds - 3 pc & 4 pc.:** Standard shrouds are available for this insert and will fit most applications. Custom shrouds may be ordered on a non-returnable basis. When ordering a custom shroud, please specify the existing fireplace front opening height and width. An upper hood and lower grill are included with fireplace.

**or**

**Blank Shrouds - 3 & 4 pc.:** Blank shrouds are available for on-site custom fit applications and are sized to the opening after the insert has been installed. The interior perimeter is properly sized to fit onto the insert. The outer perimeter must be cut, formed and finished (painted). An upper hood and lower grill are included with fireplace.

**or**

**Full Door Shrouds:** Full door decorative shrouds are available for this insert and are used in place of a standard or blank shroud. An upper hood and lower grill are included with fireplace.

## PLACEMENT CLEARANCE REQUIREMENTS

- This fireplace must be installed on a level surface capable of supporting the fireplace and venting.
- Fireplace must be placed directly on wood or non-combustible surface (not linoleum or carpet) extending the entire depth and width of fireplace.
- Due to high surface temperatures, fireplace should be located out of traffic and away from furniture and draperies.
- This fireplace may be installed in a bedroom.
- Please be aware of the large amount of heat this fireplace will produce when determining a location.



# EXISTING FIREPLACE SPECIFICATIONS

THIS INSERT IS APPROVED FOR INSTALLATION IN MASONRY AND FACTORY-BUILT SOLID FUEL BURNING FIREPLACES.

## EXISTING FIREPLACE REQUIREMENTS

The existing fireplace & chimney must be clean and in good working order and constructed of non-combustible materials.

A gas line must be able to be installed to the insert.

Provisions made to provide electrical power to operate the insert fan and thermostatic control (if used).

Any chimney clean-outs must fit properly.

Existing Chimney must be comprised of one of the following: Class 'A' metal chimney: 7" minimum inside diameter.  
Masonry Chimney: 6" x 8" minimum inside diameter.

Existing Chimney Height: Minimum: 12 ft. (3.66m)  
Maximum: 30 ft.(9.14m)

### Determine length of your existing chimney:

1. Remove and discard existing chimney cap.

 **NOTE: It is helpful to have two people complete the next step in determining chimney height.**

2. Measure from fireplace base to the top of chimney.  
Subtract 19-1/2" (489 mm) (height of insert).  
This is the total length of co-linear flexible aluminum you will require.

MEASUREMENT FROM FIREPLACE BASE TO TOP OF CHIMNEY: \_\_\_\_\_  
LESS 19-1/2" (489 mm) (HEIGHT OF INSERT): - 19-1/2" (489 mm)  
TOTAL CHIMNEY LENGTH REQUIRED: \_\_\_\_\_

 **CAUTION: THIS APPLIANCE MUST NOT BE CONNECTED TO A CHIMNEY FLUE SERVING A SEPARATE SOLID-FUEL BURNING APPLIANCE.**

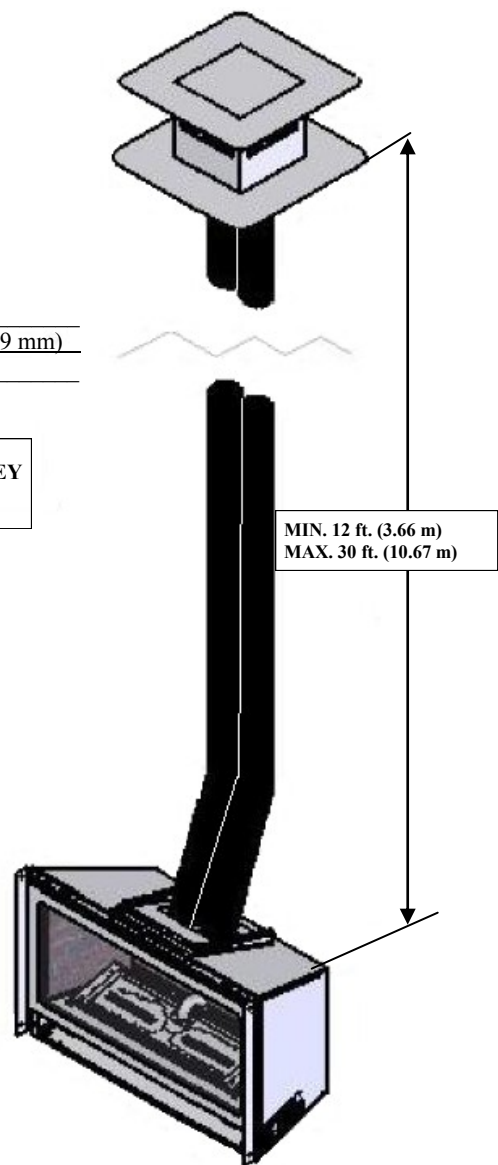

# PREPARE THE EXISTING FIREPLACE

## EXISTING FIREPLACE MINIMUM OPENING REQUIREMENTS

- (A) Height: 19-1/2" (495 mm)
- (B) Front Width : 31" (787 mm)
- (C) Depth: 15-1/4" (387 mm)
- (D) Back Width : 23-7/8" (606 mm)

All dimensions are minimum requirements

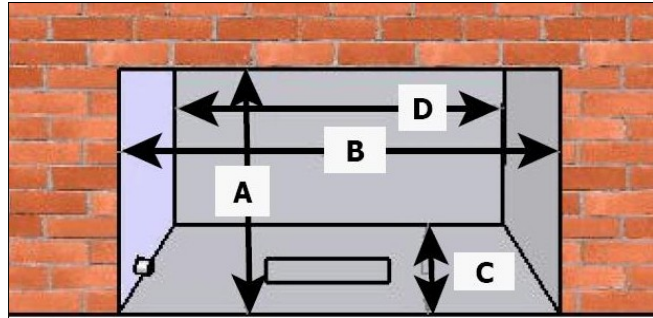

## PREPARE THE EXISTING FIREPLACE



**WARNING: CUTTING ANY SHEET-METAL PARTS OF THE FIREPLACE, IN WHICH THE GAS FIREPLACE IS TO BE INSTALLED, IS PROHIBITED.**

1. The refractory, glass doors, screen rails, screen mesh and log grates may be removed from existing fireplace before installing this gas fireplace insert.
2. Any smoke shelves, shields and baffles may be removed if attached by mechanical fasteners.
3. If necessary, remove firebrick on sides and back of the existing fireplace to obtain at least the minimum opening requirements listed above.
4. The fireplace flue damper can be fully blocked open or removed for installation of this gas fireplace insert.
5. Remove existing chimney cap.
6. Clean chimney and inside of fireplace to prevent creosote smell from entering the home.
7. Place 'THIS UNIT HAS BEEN MODIFIED' label in the bottom of existing firebox so it will be visible if this gas fireplace insert is removed.
8. Run electrical wiring if hard wiring to the pre-installed electrical box in the insert if desired. See 'FAN DIRECT WIRE INSTALLATION' instructions on following pages.
9. Run any electrical wiring needed if insert is to be run by a thermostat.

# CSK-31 (only) FAN DIRECT WIRE INSTALLATION

**DIRECT WIRE CONNECTION MUST BE PERFORMED BY A QUALIFIED ELECTRICIAN.**

This fireplace insert comes complete with a fan and thermostatic control switch already installed. A speed control, receptacle, and 8 ft. (2.44 m) fan cord have been installed, wired and mounted in a removable electrical box panel on the right side of the fireplace. If wiring to the pre-installed electrical box is desired, the wiring should be run prior to permanently setting the insert in place and connecting the vent system.



**NOTE:** If this fireplace insert is being installed in the minimum opening dimensions, the wiring may need to be completed after the fireplace insert is set in place.



**WARNING:** This appliance is equipped with a three-prong (grounding) plug for protection against shock hazard and should be plugged directly into a properly grounded three-prong receptacle. Do not cut or remove the grounding prong from this plug. Do not allow any excess fan cord to touch the fireplace.



**NOTE:** Code approved line voltage wiring 14 gauge or better must be used when wiring this assembly. Refer to your local electrical codes for specific requirements in your area.

## DIRECT WIRE INSTALLATION:



**NOTE:** The cord must be removed and wiring disassembled.

Insert 110V-120V wiring (with ground) through the romex connector and wire to speed control / receptacle assembly, matching black, white & green (ground) wires to the corresponding wires on the speed control / receptacle assembly.

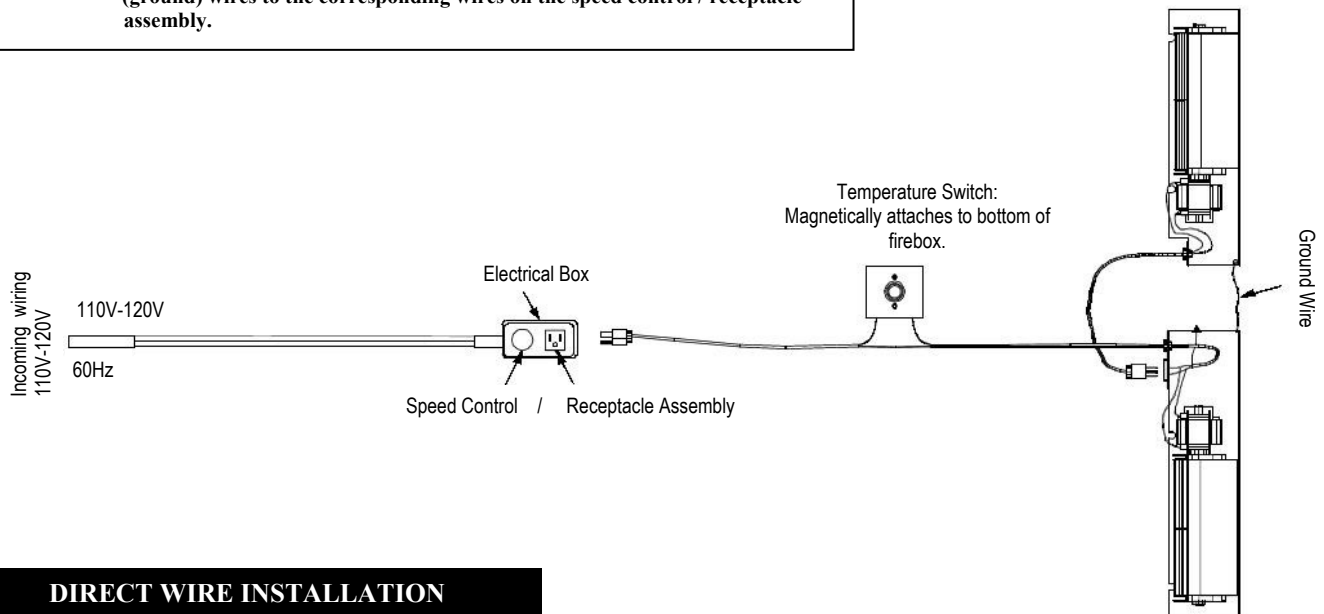

## DIRECT WIRE INSTALLATION

1. Loosen (but do not remove) screw securing removable access panel (with electrical box & romex connector installed) from the right side of fireplace. Remove access panel.
2. Remove (2) screws securing speed control / receptacle to expose wiring.
3. Remove existing cord and insert 110V-120V wiring (with ground) through romex connector, wiring to speed control / receptacle assembly, matching black (hot), white (neutral), and green (ground) wire to the corresponding wires on speed control / receptacle assembly. NOTE: The (3) wire nuts obtained when removing existing cord may be used for this purpose.
4. Secure speed control / receptacle assembly into the electrical box with (2) screws provided.

**Refer to page 19 for instructions on completing fan wiring after insert has been installed.**

*This appliance, when installed, must be electrically grounded in accordance with local codes, or in the absence of local codes, with the National Electrical Code, ANSI/NFPA 70, or the Canadian Electrical Codes, CSA C22.1*

# CSK-31-RF (only) FAN DIRECT WIRE INSTALLATION

**DIRECT WIRE CONNECTION MUST BE PERFORMED BY A QUALIFIED ELECTRICIAN.**



**IMPORTANT:** A fan assembly is pre-installed and wired to the RF gas valve in CSK-31-RF models.

A receptacle and 8 ft. (2.44m) fan cord have been installed, wired, and mounted in a removable electrical box panel on the right side of the fireplace. If direct wiring to the pre-installed electrical box is desired, wiring should be completed prior to permanently positioning insert and connecting the vent system.



**NOTE:** If this fireplace insert is being installed in the minimum opening dimensions, the wiring may need to be completed after the fireplace insert is set in place.



**WARNING:** This appliance is equipped with a three-prong (grounding) plug for protection against shock hazard and should be plugged directly into a properly grounded three-prong receptacle. Do not cut or remove the grounding prong from this plug. Do not allow any excess fan cord to touch the fireplace.



**NOTE:** Code approved line voltage wiring 14 gauge or better must be used when wiring this assembly. Refer to your local electrical codes for specific requirements in your area.

## DIRECT WIRE INSTALLATION:



**NOTE:** The cord must be removed and wiring disassembled.

Insert 110V-120V wiring (with ground) through the romex connector and wire to speed control / receptacle assembly, matching black, white & green (ground) wires to corresponding wires on the receptacle.

## DIRECT WIRE INSTALLATION

1. Loosen (but do not remove) screw securing removable access panel (with electrical box & romex connector installed) from the right side of fireplace. Remove access panel.
2. Remove (2) screws securing speed control / receptacle to expose wiring.
3. Remove existing cord and insert 110V-120V wiring (with ground) through romex connector, wiring to speed control / receptacle assembly, matching black (hot), white (neutral), and green (ground) wire to the corresponding wires on speed control / receptacle assembly.  
NOTE: The (3) wire nuts obtained when removing existing cord may be used for this purpose.
4. Secure speed control / receptacle assembly into the electrical box with (2) screws provided.

**Refer to page 19 for instruction on completing fan wiring after insert has been installed.**

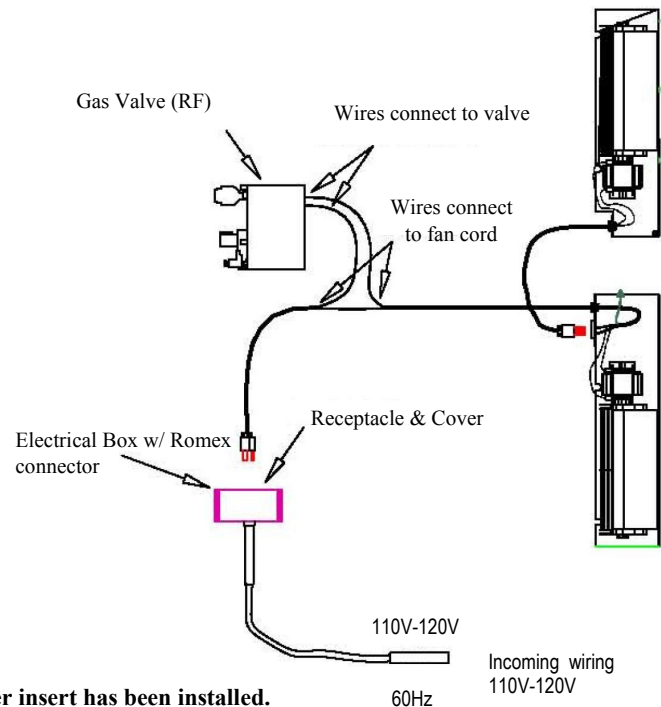

*This appliance, when installed, must be electrically grounded in accordance with local codes, or in the absence of local codes, with the National Electrical Code, ANSI/NFPA 70, or the Canadian Electrical Codes, CSA C22.1*

# THERMOSTAT / WALL SWITCH / REMOTE (CSK-31 only)

 **CAUTION: DO NOT CONNECT HIGH VOLTAGE (115V) WIRE TO THE GAS VALVE!**

 **NOTE: INSTALLATION OF THERMOSTAT OR WALL SWITCH SHOULD ONLY BE DONE BY A QUALIFIED INSTALLER.**

If desired, a thermostat (wireless style also available), wall switch, or remote control assembly may be used to turn the fireplace 'OFF' and 'ON'. Only ONE of these may be installed. Follow instructions included with each assembly.

**OPTIONAL:**  
Disconnect ON/OFF rocker switch wires from the back of gas valve.

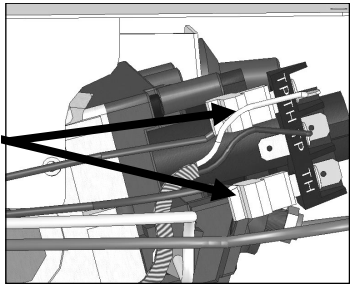

## WALL SWITCH / THERMOSTAT:

Run low-voltage (thermostat) wires from terminals on the gas valve to the desired location of wall switch or thermostat.

Attach the appropriate connectors to wall switch / thermostat wires and connect to the top and bottom terminals marked TH / TPTH on the gas valve.

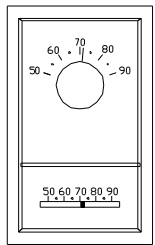

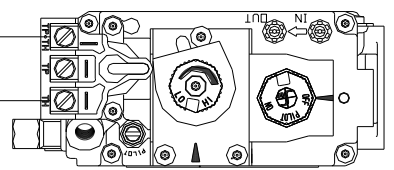

**Thermostat Wiring Diagram**



## REMOTE CONTROL:

Follow instructions included with the remote control.

 **IMPORTANT: The insulated cover included with the remote control must be placed over the remote receiver to prevent overheating.**

 **IMPORTANT: If ON/OFF rocker switch wires are not disconnected, the ON/OFF rocker switch on the millivolt board must be in the 'OFF' position for proper operation of any of these components.**

If rocker switch is 'ON', the fireplace burner will operate until it is turned 'OFF' by the rocker switch. A wall switch, thermostat, or remote control will not turn the fireplace 'OFF' when it has been turned 'ON' by the rocker switch.

 **NOTE: The fireplace must be turned 'ON' and 'OFF' by the same method. For example: If fireplace is turned 'ON' by the remote control, it must be turned 'OFF' by the remote control.**

**Remote Control Wiring Diagram**

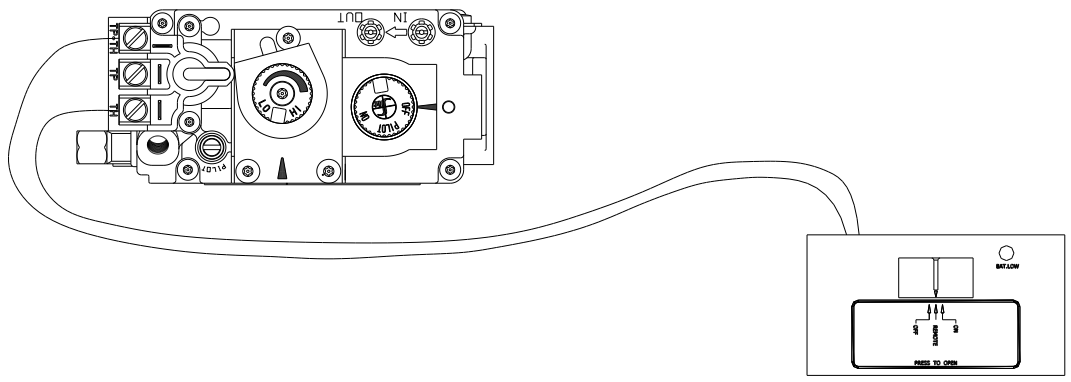

# GLASS FRAME ASSEMBLY

## REMOVE GLASS FRAME ASSEMBLY

- A. Locate the spring-loaded latches securing glass frame assembly at bottom of firebox.
- B. Pull bottom latches out and 'down' to release glass frame assembly bottom.
- C. Lift glass frame assembly up off tabs located at top of firebox.



**WARNING: DO NOT OPERATE THIS FIREPLACE WITH THE GLASS REMOVED, CRACKED OR BROKEN. REPLACEMENT OF GLASS FRAME ASSEMBLY, #CSK-057T SHOULD BE DONE BY A LICENSED OR QUALIFIED SERVICE PERSON.**

**WARNING: DO NOT REMOVE GLASS ASSEMBLY WHEN HOT!**

## INSTALL GLASS FRAME ASSEMBLY

- A. Align slots at top of glass frame assembly over tabs at top of firebox while lowering bottom of glass frame assembly into position.
- B. Pull bottom latches out and 'up' to secure glass frame assembly bottom.

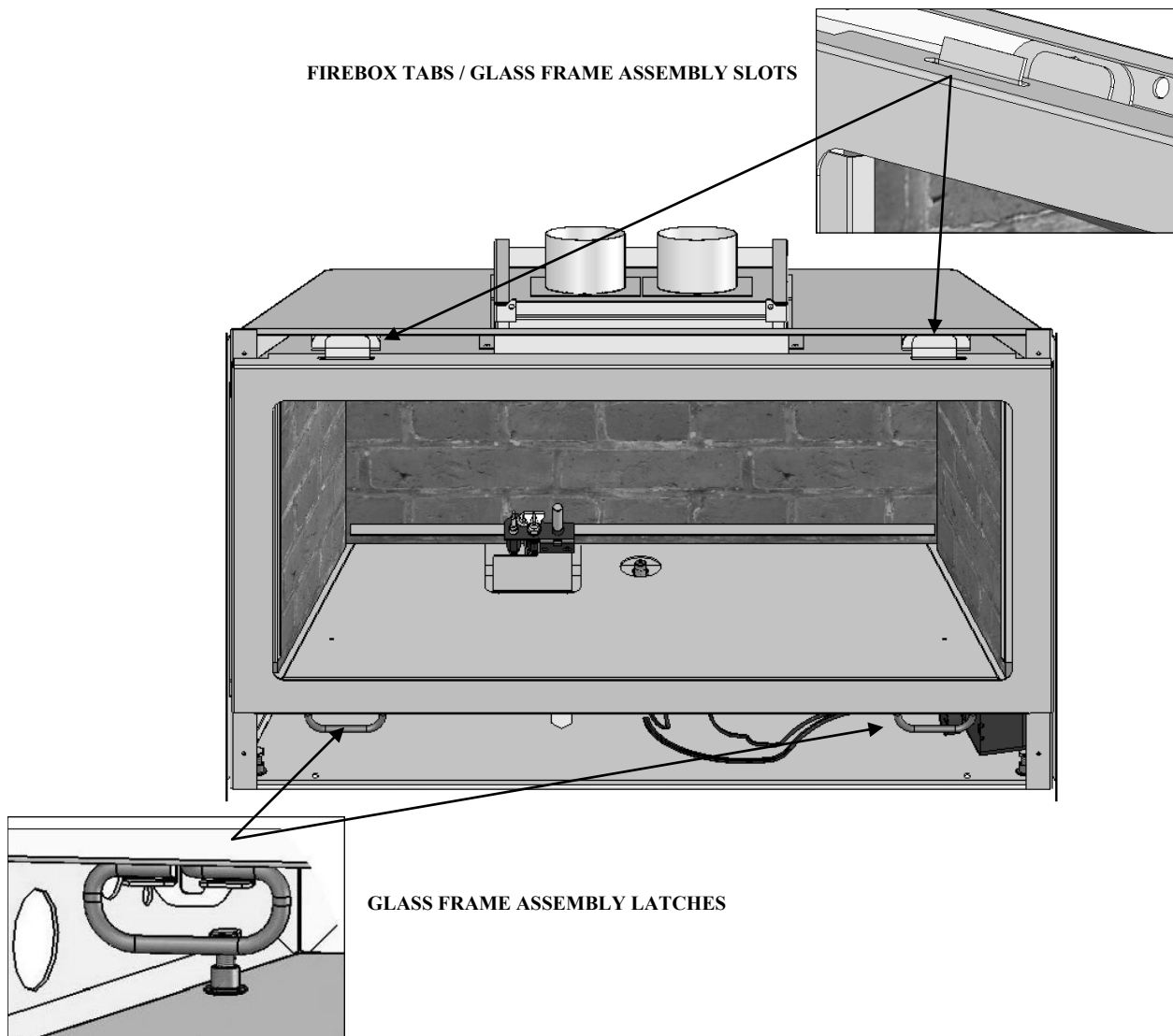

# INSTALLATION



**IMPORTANT: ALL STEPS AS OUTLINED IN 'PREPARE THE EXISTING FIREPLACE' MUST BE COMPLETED BEFORE CONTINUING WITH THIS INSTALLATION.**

## APPROVED VENTING

Kozy Heat #816-CL Co-Linear Vent System. Follow instructions on following pages.

ICC

Selkirk

American Metals

Simpson Dura-Vent

Follow instructions included from vent pipe manufacturer as well as the venting requirements as outlined in this installation manual.

## COMBUSTION AIR VENTING OPTIONS

**OPTION 1: FULL CONNECTION:** The combustion air intake pipe is run the entire chimney length and connected to the termination cap.

**OPTION 2: STUB VENTING:** A 3" combustion air intake pipe is extended a minimum of 4 ft. (1.22 m) past the damper opening and into existing chimney. It is not connected to the termination cap.

## AIR DUCT REMOVAL

Remove the air duct, located at the top of insert, by sliding it back out of the channel. Follow instructions on following pages for vent system attachment to the air duct.

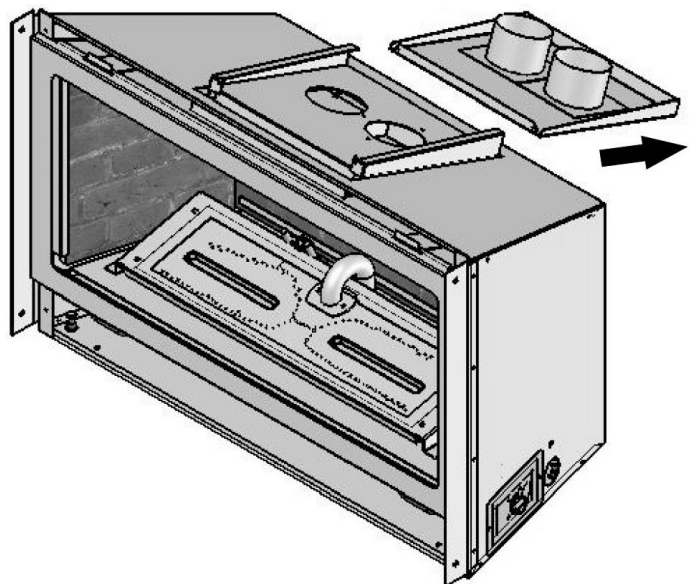

# KOZY HEAT #816-CL CO-LINEAR VENT SYSTEM

The co-linear pipes included in this vent system are designed to extend up to 35 ft. (10.67m)



**IMPORTANT:** The 3" exhaust pipe can be identified by the red marking. It is imperative for proper operation of this insert that the exhaust and combustion air pipes be connected to the correct collar both on the termination kit and air duct on the insert.

A. Carefully extend the 3" exhaust and combustion air intake pipes to equal the total chimney length required.



**NOTE:** If using 'stub' method for the combustion air pipe, extending it is not necessary. Determine length needed from the air duct on insert (4 ft. (1.22 m) minimum) to above the damper opening in the existing chimney. Remove excess combustion air pipe from end without a collar. Continue with Step B. #2 below.

B. 1. If using 'Full Connection' method:

Slide 3" intake pipe (end without collar) over collar on termination cap. Secure with 3 self-tapping screws (provided).

2. Place a bead of sealant around inner edge at end of 3" exhaust pipe (without collar / red marking) and slide onto corresponding collar on termination cap (collar with label). Secure with 3 self-tapping screws (provided). Apply additional sealant around joint to ensure a proper seal.

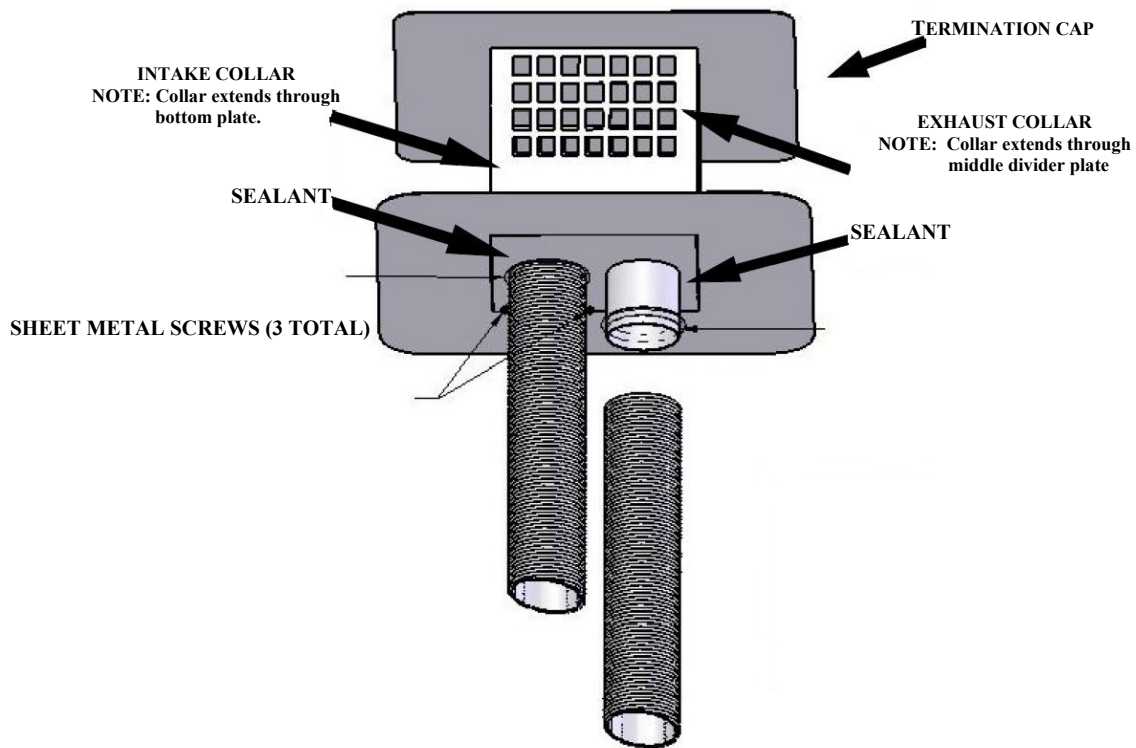

**IMPORTANT:** THE EXHAUST COLLAR ON FIREPLACE AIR DUCT IS ON THE RIGHT SIDE. INSTALL TERMINATION CAP WITH EXHAUST COLLAR ON RIGHT SIDE.



# RUN VENT SYSTEM THROUGH EXISTING CHIMNEY

We strongly suggest wrapping the first 3 ft.(914 mm) of vent system below the termination cap with non-faced fiberglass insulation (secure with wire) before running it through the existing chimney. This will prevent cold air from coming down the existing chimney.

**DO NOT USE THIS METHOD IF YOU ARE STUBBING THE 3" COMBUSTION AIR PIPE FROM BOTTOM OF EXISTING CHIMNEY!**

 **NOTE:** If offsets are present in existing chimney, it may be easier to place a weighted rope around the end of each 3" pipe to guide them through it. **DO NOT ATTEMPT TO TIE ONE ROPE AROUND BOTH PIPES.**

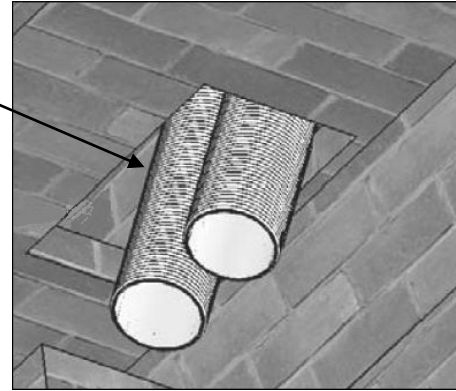

1. Guide rope, if used, and flexible pipe(s) down existing chimney. See illustration at lower left.
2. To secure chimney termination cap to the existing chimney, apply a liberal bead of sealant (provided) around the top of existing chimney. Set termination cap into position as instructed in installation manual included with chosen vent system .

**OPTIONAL:** #816-CL kits - Secure the termination cap to existing chimney with 2" self-tapping screws and anchor straps provided through pilot holes located at the sides of termination cap.

3. From inside existing fireplace opening, CAREFULLY pull ropes down until 3" exhaust pipe and 3" combustion air intake (if using 'full connection method'), are into existing fireplace.

**STUB VENTING:** From inside existing fireplace, insert a minimum of 4ft. (1.22m) of combustion air pipe (end without collar) past the damper opening and into existing fireplace. See illustration at lower right.

4. We strongly suggested placing non-faced fiberglass insulation between vent pipes and existing chimney to prevent heat loss up the chimney, being careful not to block end pipe if using stub method.

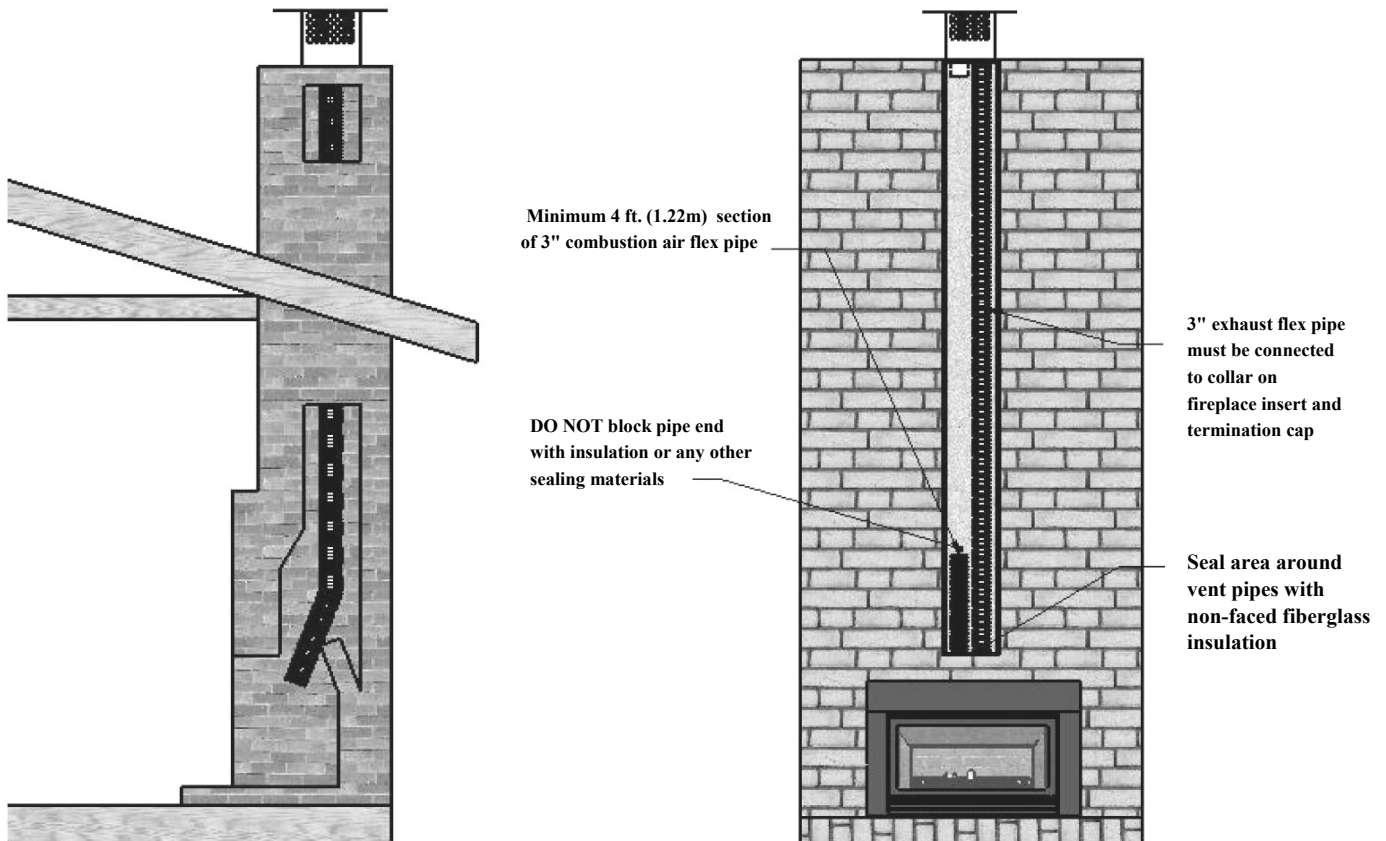

# CONNECT VENT SYSTEM TO AIR DUCT

1. Place air duct (previously removed from insert top, page 14) into the existing fireplace opening.
2. Place a bead of sealant (provided) around 3" exhaust pipe (red marking). Slide exhaust pipe inside 3" collar marked 'Exhaust' on the air duct. Secure with (3) 1/2" self-tapping screws, provided. Apply additional sealant around the joint to ensure an air-tight seal.
3. Apply a liberal bead of sealant (provided) around 3" collar on the air duct. Slide 3" combustion intake pipe over the collar. Secure with (3) 1/2" self-tapping screws, provided. To ensure an air-tight seal, apply additional sealant around the joint.

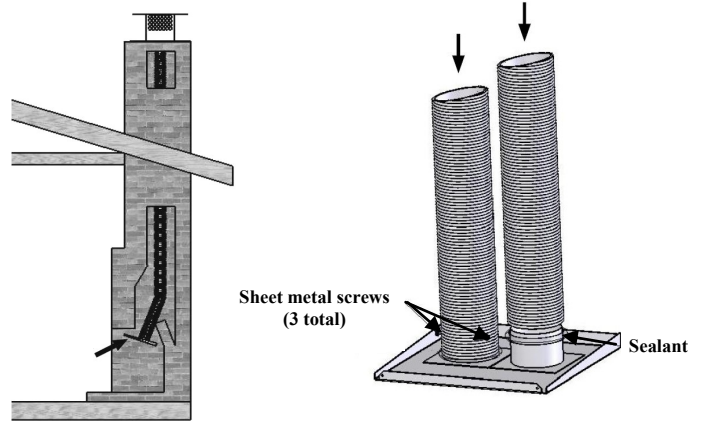

# POSITION FIREPLACE INSERT

1. Slide insert into fireplace opening.

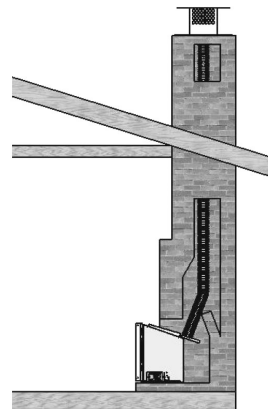

2. Position air duct into channels located at top of insert. Slide air duct forward until seated.

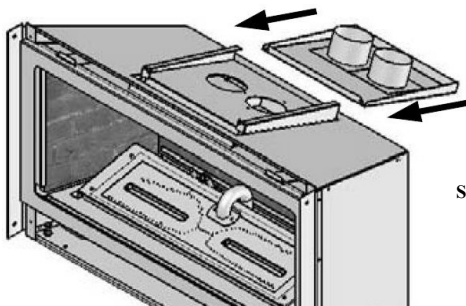

Shown without venting attached for clarity purposes only

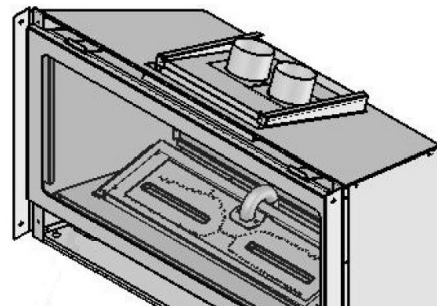

3. Secure air duct to insert front with (2) 1/2" sheet metal screws (included in components packet).

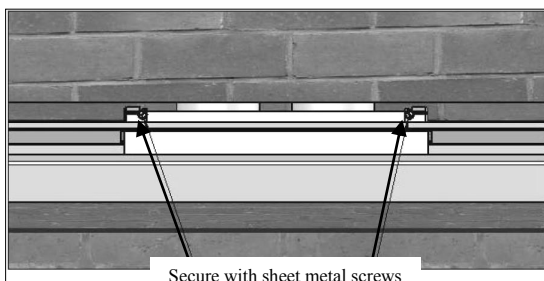

4. If necessary, level insert by threading leveling bolts (included in components packet) into nuts mounted in the bottom of insert behind lower air passage - 2 each side.

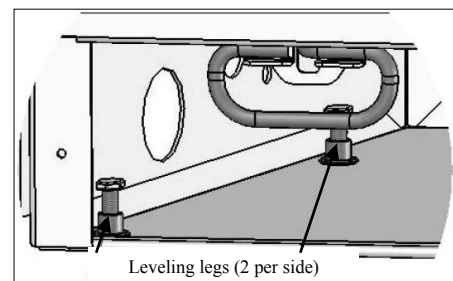

# GAS LINE CONNECTION



**IMPORTANT:**  
DO NOT RUN GAS LINE IN A MANNER THAT WOULD OBSTRUCT THE OPERATION OF THE FAN OR FAN COMPONENTS.

Run gas line into the fireplace, preferably through the left or right gas line holes provided. A gas line knock-out is also located in the outer bottom of insert if running the gas line through the bottom is the only option.



**NOTE:** If installing this insert into minimum opening dimensions, the gas line may need to be run after the insert is in place due to space limitations.

If installing this gas fireplace insert into a factory-built fireplace and the factory-built fireplace has no access hole provided, an access hole of 1 1/2" (38 mm) or less may be drilled through the lower sides or bottom of the firebox in a proper workmanship like manner. This access hole must be plugged with non-combustible insulation after the gas supply line has been installed.

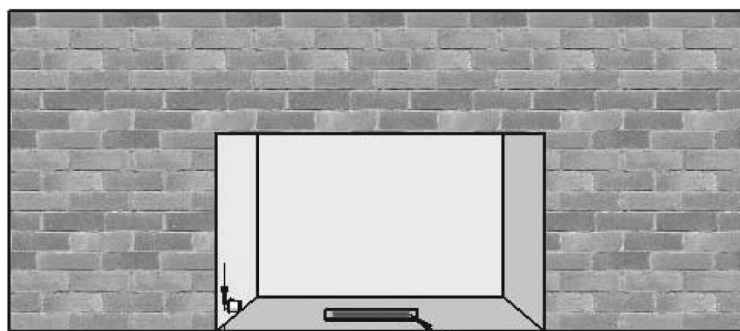

1-3/8" (35 mm) from bottom to gas line

WARNING LABEL

	<b>CSK-31 / CSK-31-RF</b>	
	<b>NATURAL GAS</b>	<b>LP GAS</b>
MINIMUM INLET GAS PRESSURE	5.0 inches W.C. (7.0 W.C. recommended)	11.0 inches W.C. (recommended)
MAXIMUM INLET GAS PRESSURE	10.5 inches W.C.	13.0 inches W.C.
MANIFOLD PRESSURE (HI)	3.5 inches W.C.	10.0 inches W.C.
MANIFOLD PRESSURE (LO)	1.7 inches W.C.	6.3 inches W.C.
ORIFICE SIZE	#37	#52
INPUT BTU/hr.	27,500	28,000
MINIMUM INPUT BTU/hr.	19,000	20,400
EFFICIENCY	72%	72%
AFUE	71%	72%
P-4 AFE	58%	60%

## CHECK MILLIVOLT BOARD INSTALLATION



**NOTE:** Refer to page 23 for complete millivolt board installation procedures.

1. Ensure that all (6) nuts are attached to the mounting studs, securing the millivolt board in position.
2. Verify burner venturi is properly positioned over burner orifice and the burner assembly is secured to burner heat shield.
3. Check all gas connection for leaks, whether field or factory made.

# COMPLETE FAN WIRING INSTALLATION

## #CSK-31 (only)

1. Secure electrical access panel to side of fireplace.
2. Place thermostatic control switch on bottom of firebox.
3. Plug power cord into electrical box receptacle.
4. Turn speed control counter-clockwise until it 'clicks'. This is the 'OFF' position.
5. Turn speed control 'ON' by turning the knob clockwise past the 'click' - this is the highest setting.



**NOTE: This appliance must be electrically grounded and connected in accordance with local codes, or in the absence of local codes, with the National Electrical Code, ANSI/NFPA 70 Current Edition, or the Canadian Electrical Code CSA C22.1.**

**NOTE: This fan will not operate unless the speed control has been turned 'ON' and sufficient heat has been applied to the temperature control switch. The fan will turn 'ON' and 'OFF' automatically as the fireplace heats and cools. Adjust fan to desired speed while it is running.**

### TEMPERATURE CONTROL SWITCH POSITION

Before adjusting the temperature control switch, unplug the 3-prong plug on the fan cord from the receptacle. Adjust position of the temperature control switch to a warmer location under the firebox to turn fan 'ON' sooner or move it to a cooler location under firebox to turn the fan 'ON' later. The fan will turn on when the sensor in the temperature control switch reaches 110° F and will turn 'OFF' when the sensor reaches 90° F. After adjustment, plug the 3-prong plug on fan cord into the receptacle.

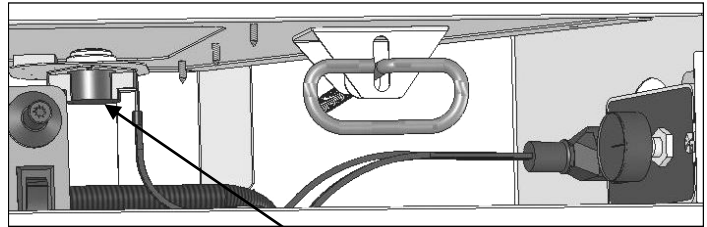

Temperature Control Switch (looking through lower grill opening).

## #CSK-31-RF (only)

1. Secure electrical access panel to side of fireplace.
2. Plug power cord into electrical box receptacle .



**NOTE: This appliance must be electrically grounded and connected in accordance with local codes, or in the absence of local codes, with the National Electrical Code, ANSI/NFPA 70 Current Edition, or the Canadian Electrical Code CSA C22.1.**

3. Upon complete installation of this fireplace, follow Lighting & Shutdown instructions as outlined in this manual as well as the instructions included with the remote transmitter for complete fan operation guidelines.

# 3 PIECE SHROUD ASSEMBLY AND INSTALLATION



**NOTE:** If installing a Full Door Shroud, follow instructions included with that component.

Shroud assembly includes:

(1) Shroud top	(2) 10-24 x 1" RH Philips Mch Screw (#300388)
(1) Shroud left side	(6) 8 x 3/8" Phillips PH-Type B Blk Zinc SMS (#300121)
(1) Shroud right side	(4) 10-24 x 1/2" PH Phillips Truss head Screw BZ (300338-1)

You will also need the flanged upper hood and lower grill which are included with fireplace.

1. Remove glass assembly from fireplace.
2. Lay shroud sections face down on a protective surface to assemble. Note the orientation of leg sections in *Figure 1*. Attach leg sections to top section by aligning holes (2 ea. side) in top section with holes in leg sections. Secure with black phillips head sheet metal screws (2 ea. side).
3. Partially thread remaining (2) black phillips head sheet metal screws into holes located along the bottom flange of top section (1 ea. side). Do not tighten at this time. *Figure 1*.
4. Attach shroud to fireplace by aligning the (2) holes in each leg section to the corresponding mounting nuts in mounting brackets on either side of fireplace opening. Secure with phillips truss head screws (2 ea. side). Refer to *Figure 2*.

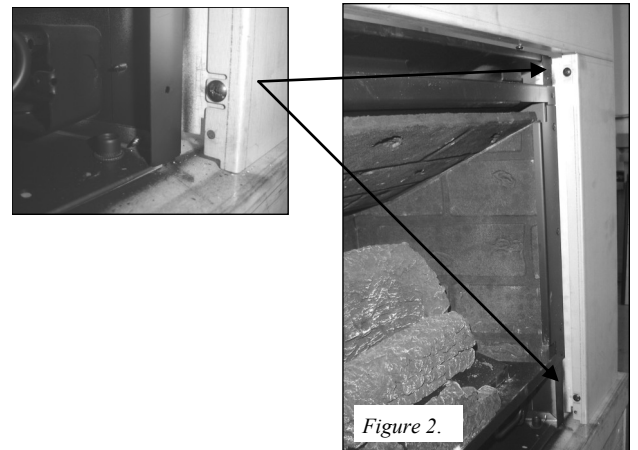
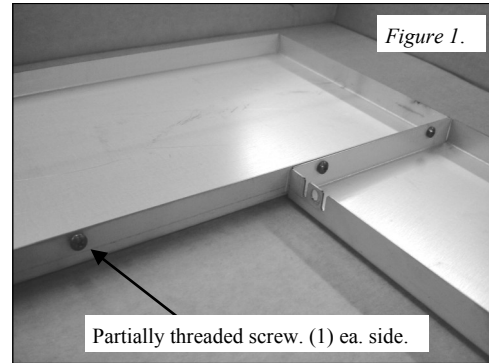

5. Install the upper hood with a flange on each end (included with fireplace) (*Figure 3*) by aligning slots in hood to the partially threaded screws in shroud top, slide hood back and tighten screws. *Figure 4*.

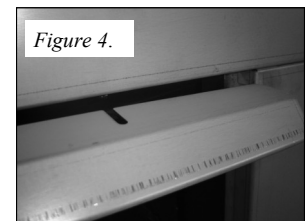
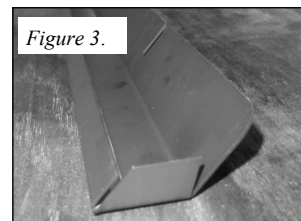

6. Attach lower grill by threading 1" phillips head screws through mounting nuts (1 ea. side) on grill and into corresponding holes located at the bottom of shroud leg sections (1 ea. side) Refer to *Figure 5*. Tighten screws.  
Note: When completed, the grill may be adjusted slightly from side to side if necessary.

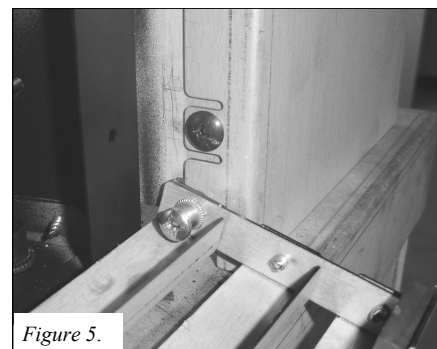

# LOG SET INSTALLATION



**ATTENTION:** If converting to LP (propane) gas, do so now before installing log set. Follow instructions included with conversion kit.



**NOTE:** Log numbers are located on the bottom of each log. Refer to following instructions and illustrations for proper placement.



**CAUTION:** Do not place logs directly over burner port holes. Improper log placement may affect flame appearance and cause excessive soot to build up on logs and glass.

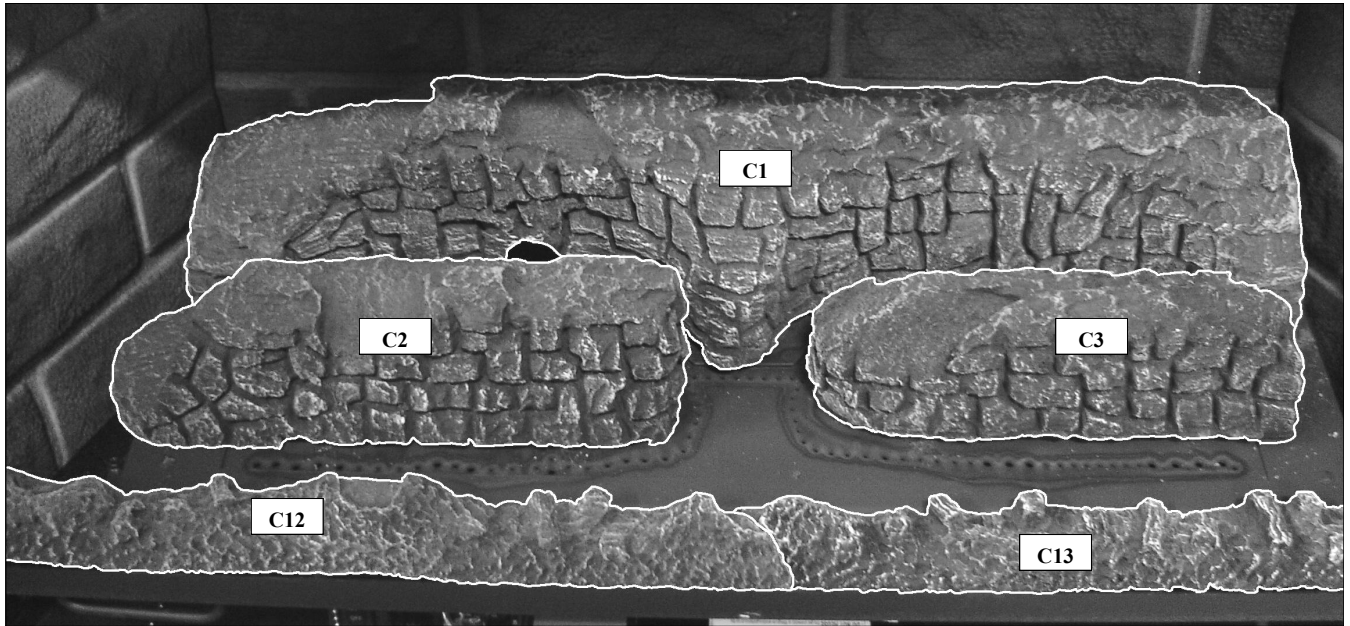

Align holes in bottom of base logs C1, C2, & C3 to mounting pins on burner. Push logs down onto pins to seat. Position ember logs C12 & C13 in front of burner as shown above.

Install C4 - C8 logs, aligning with notches in base logs.

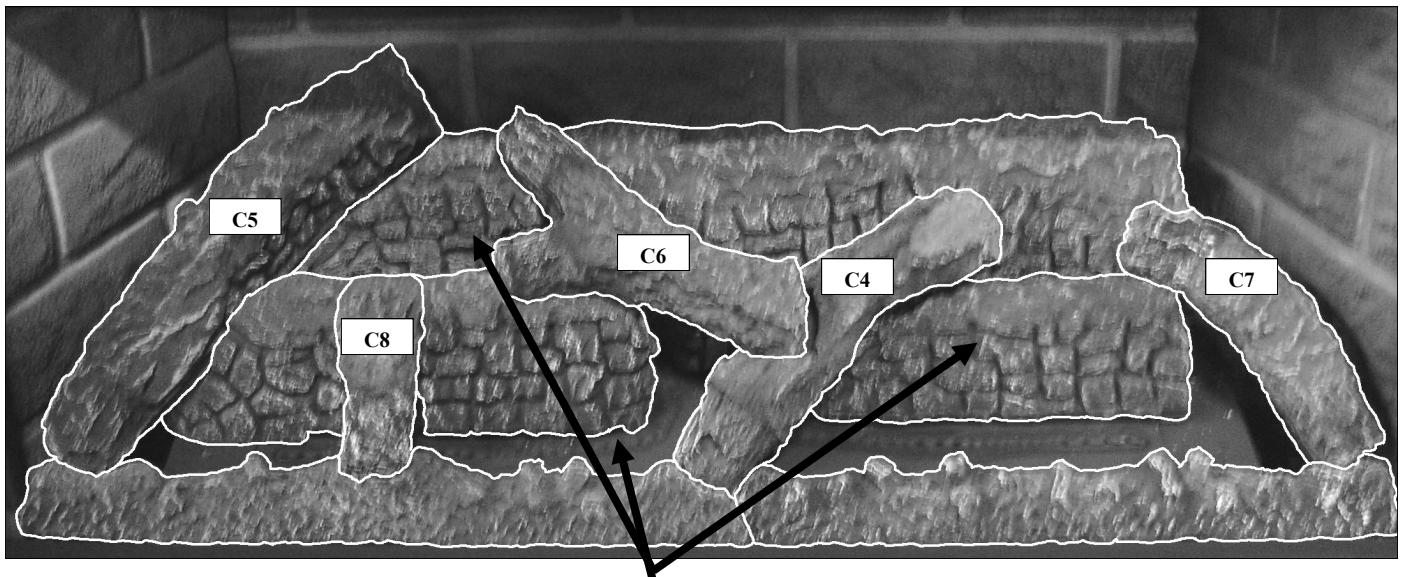

Use a steel or stiff bristle nylon brush to distribute Rock Wool Embers onto logs and burner.

# MILLIVOLT BOARD REMOVAL



**CAUTION:** If the burner and/or pilot have been burning, use the appropriate protection to avoid burns or damage to personal property before removing any components.

1. Turn gas control knob to the 'OFF' position.
2. Shut off gas supply at the manual shut-off valve.
3. Disconnect gas line flex tube from the manual shut-off valve.

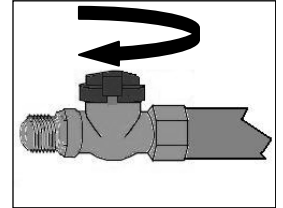
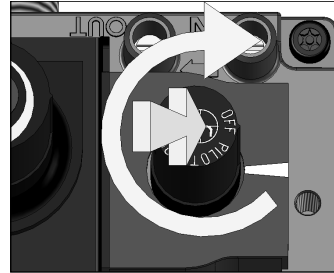

4. **Model CSK-31:**  
Disconnect any wall switch, remote control, or thermostat wires from 'TH' / 'THTP' terminals on the gas valve.

**Model CSK-31-RF:**

Unplug fan cord from receptacle, disconnect the (2) wires from fan cord. (Wires will remain connected to the back of gas valve).

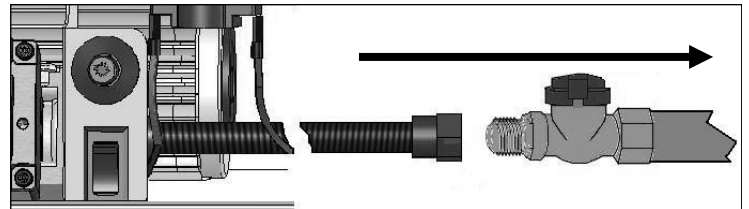

5. Remove glass assembly. Page 13.



**NOTE:** It is not necessary to remove the shroud or full door shroud to remove millivolt board.

6. Remove logs.
7. Remove screws securing burner assembly. Remove burner assembly from firebox.
8. Remove burner heat shield from firebox.
9. Remove (6) nuts securing millivolt board. Lift board up and out of firebox.

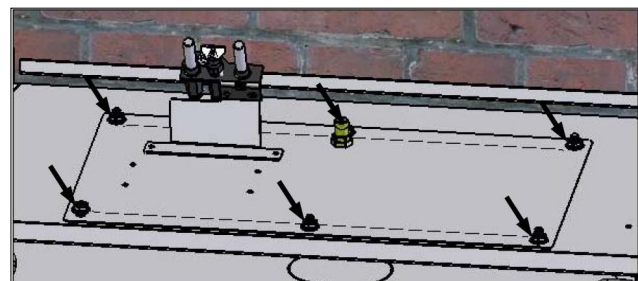
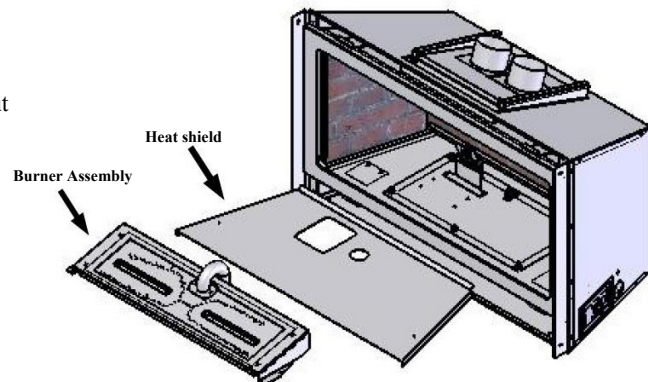
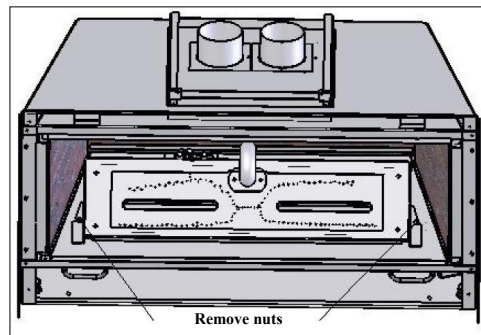

# MILLIVOLT BOARD INSTALLATION



**WARNING: DO NOT OPERATE THIS FIREPLACE WITHOUT SEALING GASKET (LOCATED UNDER THE MILLIVOLT BOARD) IN PLACE. IF GASKETING IS DAMAGED, IT MUST BE REPLACED.**

1. Place millivolt board in firebox, aligning holes in the millivolt board with mounting studs in the firebox bottom. **MAKE SURE SEALING GASKET IS IN PLACE ON FIREBOX BOTTOM!** Secure millivolt board to firebox bottom with the (6) nuts previously removed.
2. Re-install burner heat shield, positioning cut-outs over pilot assembly and burner orifice, centering from side to side and as far back as possible.
3. Re-install burner assembly, making sure burner tube is positioned over burner orifice, and alignment slots are placed over mounting studs in burner heat shield. Secure with nuts previously removed.
4. Reinstall log set. Page 21.
5. Reconnect gas line to manual shut-off valve.
6. **Model CSK-31:**  
Reconnect any wall switch, remote control or thermostat wires to terminals on the gas valve marked 'TH' / 'THTP'.
- Model CSK-31-RF:**  
Re-connect the (2) wires to fan cord. Plug fan cord into receptacle.
7. Reinstall glass frame assembly. Page 13.
8. Turn gas on.
9. Verify proper log placement, operation of fireplace, and any electrical components.

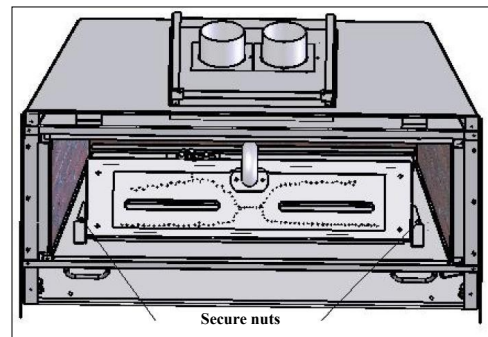
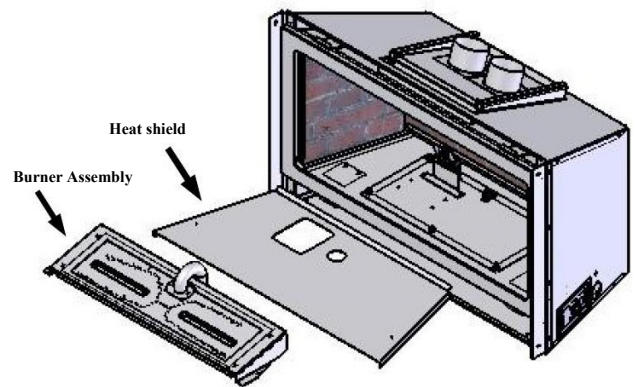
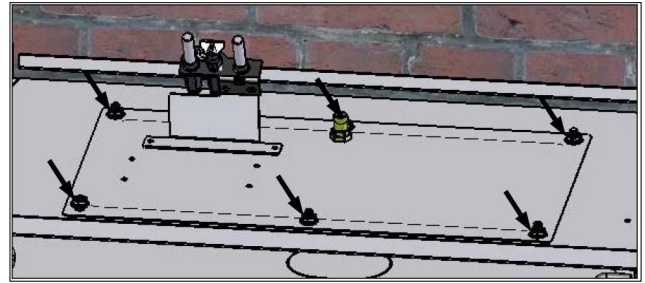

**CAUTION: CHECK ALL CONNECTIONS FOR LEAKS, WHETHER FIELD OR FACTORY MADE.**

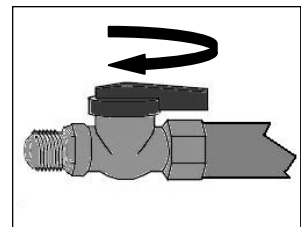
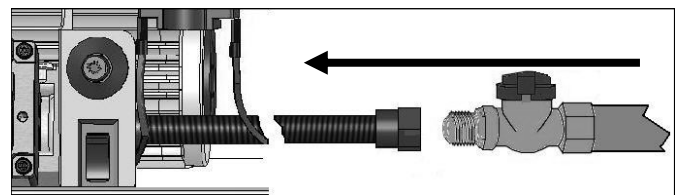



# CSK-31 VALVE & PILOT ASSEMBLY COMPONENTS

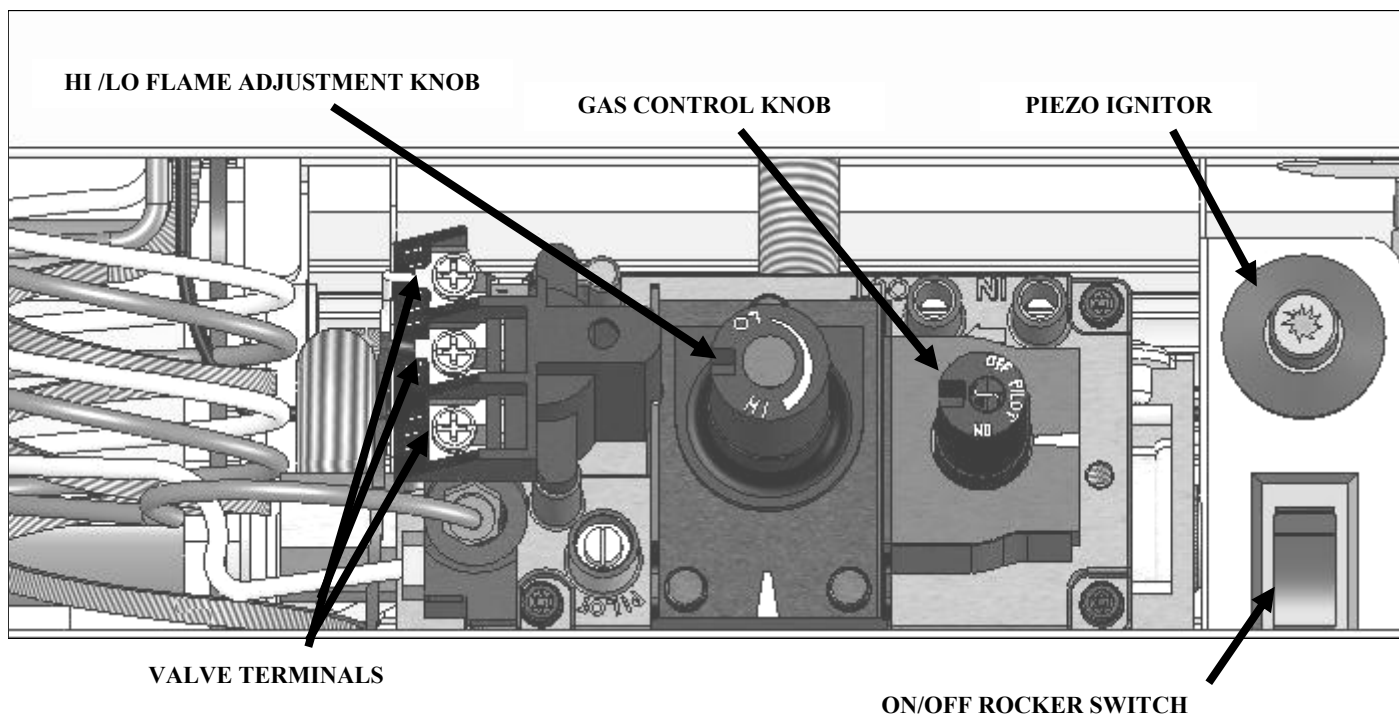
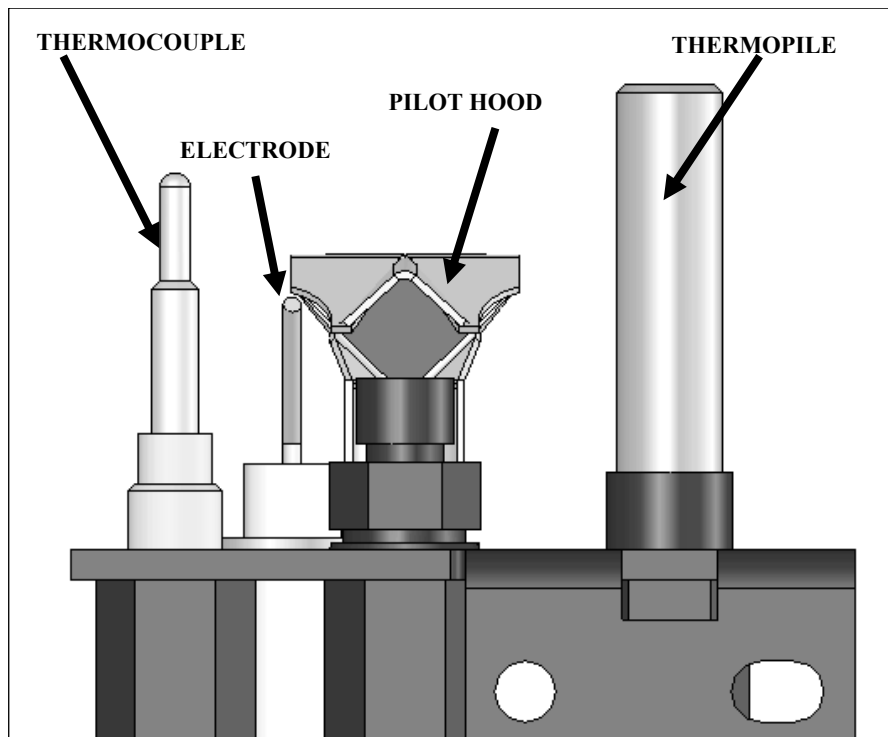

# CSK-31 LIGHTING AND SHUTDOWN

## FOR YOUR SAFETY - READ BEFORE LIGHTING



**WARNING: IF YOU DO NOT FOLLOW THESE INSTRUCTIONS EXACTLY, A FIRE OR EXPLOSION MAY RESULT, CAUSING PROPERTY DAMAGE, PERSONAL INJURY OR LOSS OF LIFE.**

**DUE TO HIGH SURFACE TEMPERATURES, KEEP CHILDREN, CLOTHING AND FURNITURE AWAY.**

This appliance needs fresh air for safe operation and must be installed so there are provisions for adequate combustion and ventilation air.

1. This appliance has a pilot which must be lighted by hand. When lighting the pilot, follow these instructions exactly.
2. **BEFORE LIGHTING**, smell all around the appliance for gas. Be sure to smell next to the floor because some gas is heavier than air and will settle on the floor.
3. Use only your hand to push in or turn the gas control knob. Never use tools. If the knob will not push in, or turn by hand, do not try to repair it, call a qualified service technician. Forced or attempted repair may result in a fire or explosion, and loss of warranty.
4. Do not use this appliance if any part has been under water. Immediately call a qualified service technician to inspect the appliance and to replace any part of the control system which has been under water.

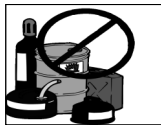

**DO NOT STORE OR USE GASOLINE OR OTHER FLAMMABLE VAPORS AND LIQUIDS IN THE VICINITY OF THIS OR ANY OTHER APPLIANCE.**

### WHAT TO DO IF YOU SMELL GAS:

- \* Do not touch any electrical switches
- \* Do not try to light any appliance
- \* Do not use the phone in your building
- \* Immediately call your gas supplier from a neighbor's phone
- \* Follow the gas supplier's instructions
- \* If you cannot reach your gas supplier, call the fire department

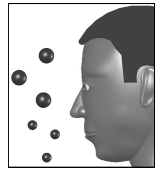

**WARNING: CHILDREN AND ADULTS SHOULD BE ALERTED TO THE HAZARDS OF HIGH SURFACE TEMPERATURES AND SHOULD STAY AWAY TO AVOID BURNS OR CLOTHING IGNITION. YOUNG CHILDREN SHOULD BE CAREFULLY SUPERVISED WHEN THEY ARE IN THE SAME ROOM AS THE APPLIANCE. CLOTHING OR OTHER FLAMMABLE MATERIAL MUST NOT BE PLACED ON OR NEAR THE APPLIANCE.**



**NOTE: A PAINT SMELL WILL OCCUR DURING THE FIRST FEW HOURS OF BURNING. IT IS RECOMMENDED TO LEAVE THE FAN OFF DURING THIS PERIOD TO HELP SPEED THE PAINT CURING PROCESS.**

**NOTE: THIS FIREPLACE MAY PRODUCE NOISES OF VARYING DEGREE AS IT HEATS AND COOLS DUE TO METAL EXPANSION AND CONTRACTION. THIS IS NORMAL AND DOES NOT AFFECT THE PERFORMANCE OR LONGEVITY OF THE FIREPLACE.**

# CSK-31 LIGHTING AND SHUTDOWN (cont.)

## LIGHTING

1. Set thermostat to the lowest setting, if installed.
2. Turn off all electrical power to the appliance. (Fan).
3. Open lower grill to access the gas valve & controls.

- A. Push gas control knob in slightly and turn clockwise to "OFF". Wait five (5) minutes to allow any gas that may have accumulated inside the firebox to escape. If you then smell gas, **STOP!** Follow the safety information on the front cover and on the previous page of this installation manual. If you don't smell gas, go to the next step.

5 MINUTES

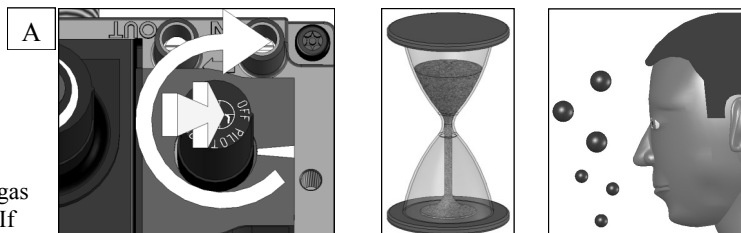

**NOTE:** Gas control knob cannot be turned from "PILOT" to "OFF" unless knob is pushed in slightly. Do not force.

- B. Locate pilot - follow metal tube from gas control. The pilot is located inside the combustion chamber.

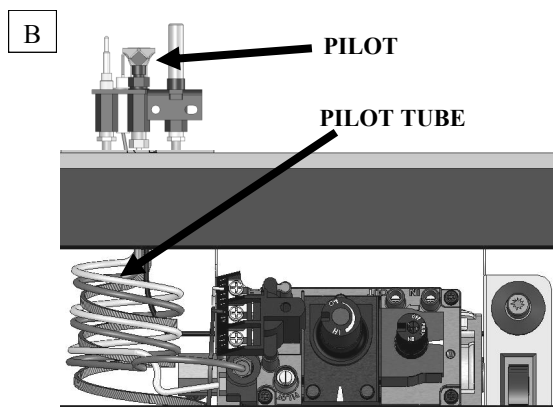

- C. Push gas control knob on the gas valve in slightly and turn counterclockwise to 'PILOT'. Push valve knob in and hold while repeatedly pressing the piezo igniter button until the pilot is lit while continuing to hold in the gas control knob.

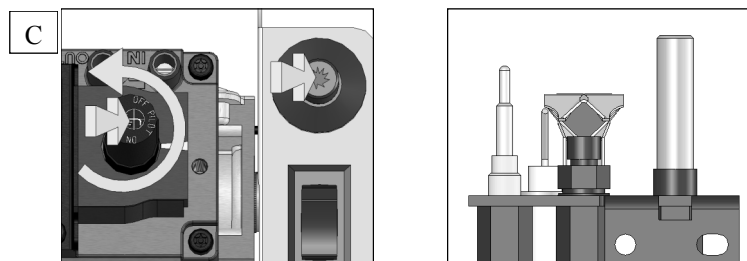

- D. Hold gas control knob in for one (1) minute after pilot is lit. Release the gas control knob. If the pilot goes out, repeat steps C-D. When the pilot is lit, proceed to step E.



**CAUTION:** If knob does not pop up when released, stop and immediately call your service technician or the gas supplier. If the pilot will not stay lit after several tries, turn the gas control knob to OFF and call your service technician or the gas supplier.

- E. Push gas control knob in slightly and turn counterclockwise to 'ON'. The burner can now be turned 'ON' by depressing the ON/OFF rocker switch located beside the valve, or wall switch, OR by setting the thermostat or remote control to the desired setting.

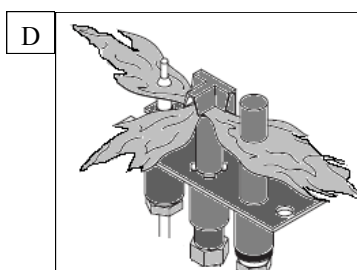

1 MINUTE



- F. Turn on all electric power to the appliance (if applicable).

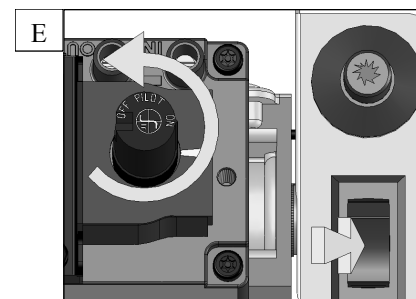

**NOTE:** When the fireplace is initially lit, condensation will appear on the glass; this is normal in all gas fireplaces and will disappear after several minutes.

# CSK-31 LIGHTING AND SHUTDOWN (cont.)

## TURN BURNER OFF

- G. To turn the burner 'OFF', depress the ON/OFF rocker switch to 'OFF', flip 'off' wall switch or adjust setting on the thermostat or remote control.



**NOTE:** The pilot will stay lit.

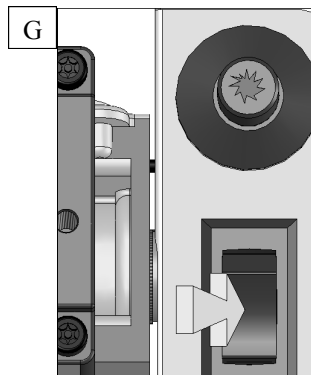

## TURN PILOT OFF

- H. Turn the pilot off by pushing in and turning the gas control knob to the 'OFF' position. **DO NOT FORCE.**



**NOTE:** This control valve has an interlock device. If pilot has been turned off, it cannot be relit until the thermocouple has cooled, (approximately 60 seconds).

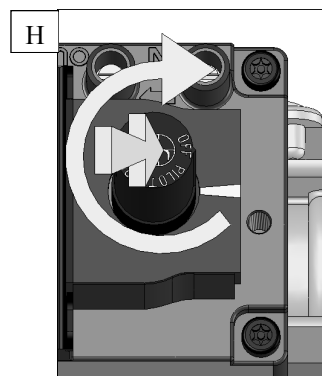

## ADJUSTING FLAME HEIGHT

The gas control valve has a HI /LO flame adjustment knob designed to allow you to tailor the look and heat output of your fireplace. Adjust by turning the middle knob on the gas control valve.

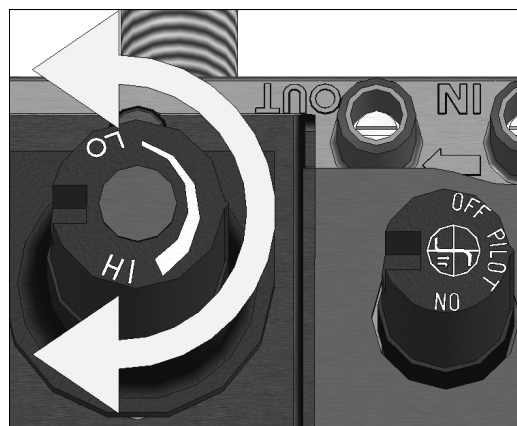

# CSK-31 PRESSURE TESTING



**IMPORTANT NOTICE:** Pressure check taps for the manifold (outgoing) and inlet (incoming) pressure have been incorporated into the valve. The pressure tap marked 'OUT' measures outgoing pressure and the pressure tap marked 'IN' measures incoming pressure. Follow instructions below for proper testing procedures.



**NOTE:** The appliance and its individual shutoff valve must be disconnected from the gas supply piping system during any pressure testing of that system at pressures in excess of ½ psi.

**NOTE:** The appliance must be isolated from the gas supply piping system by closing its individual manual shut-off valve during any pressure testing of the gas line at test pressures equal to or less than ½ psi (3.5 kPa).

## INLET PRESSURE TEST:

1. Loosen inlet ('IN') pressure tap screw (counter-clockwise).
2. Attach manometer using a 5/16" I.D. hose.
3. Light pilot.
4. Turn gas control knob to 'ON' (burner should not light). Note manometer reading.
5. Press rocker switch to 'ON'. Check pressure to ensure that it stays near the maximum inlet pressure.
6. Press rocker switch to 'OFF'.
7. Turn gas control knob to 'OFF'.
8. Disconnect hose and tighten screw (clockwise). Screw should be snug, do not over tighten.
9. Relight pilot and turn gas control knob to 'ON'. Reattach manometer to inlet pressure tap to verify that it is completely sealed. Manometer should read no pressure.



**NOTE:** If inlet pressure reading is too high or too low, contact the gas company. Only a qualified gas service technician should adjust the incoming gas pressure.

## MANIFOLD PRESSURE TEST:

1. Light pilot.
2. Loosen manifold ('OUT') pressure tap screw (counter-clockwise).
3. Attach manometer to pressure tap using a 5/16" I.D. hose.
4. Turn gas control knob to 'ON'.
5. Press rocker switch to 'ON' and note manometer reading.
6. Press rocker switch to 'OFF'.
7. Disconnect manometer hose and tighten screw (clockwise). Screw should be snug, do not over tighten.
8. Attach manometer to manifold pressure tap to verify that it is completely sealed. Manometer should read no pressure when the rocker switch is pressed to 'ON'.



**CAUTION:** A LOW PRESSURE READING CAN CAUSE DELAYED IGNITION

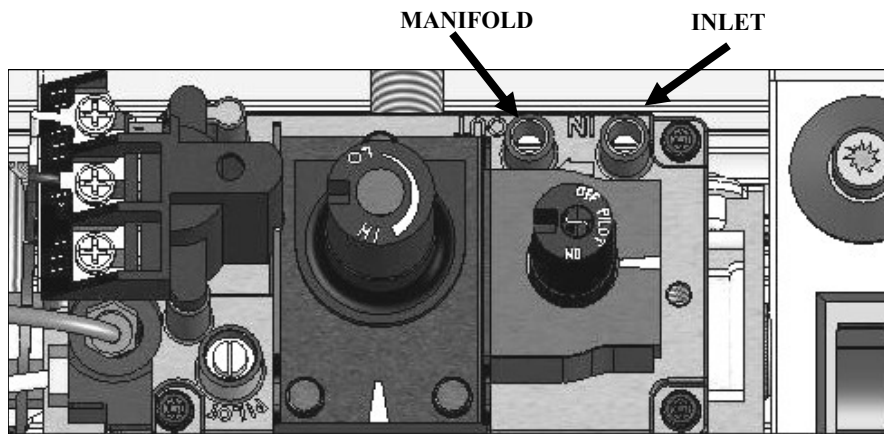

# CSK-31-RF VALVE & PILOT ASSEMBLY COMPONENTS

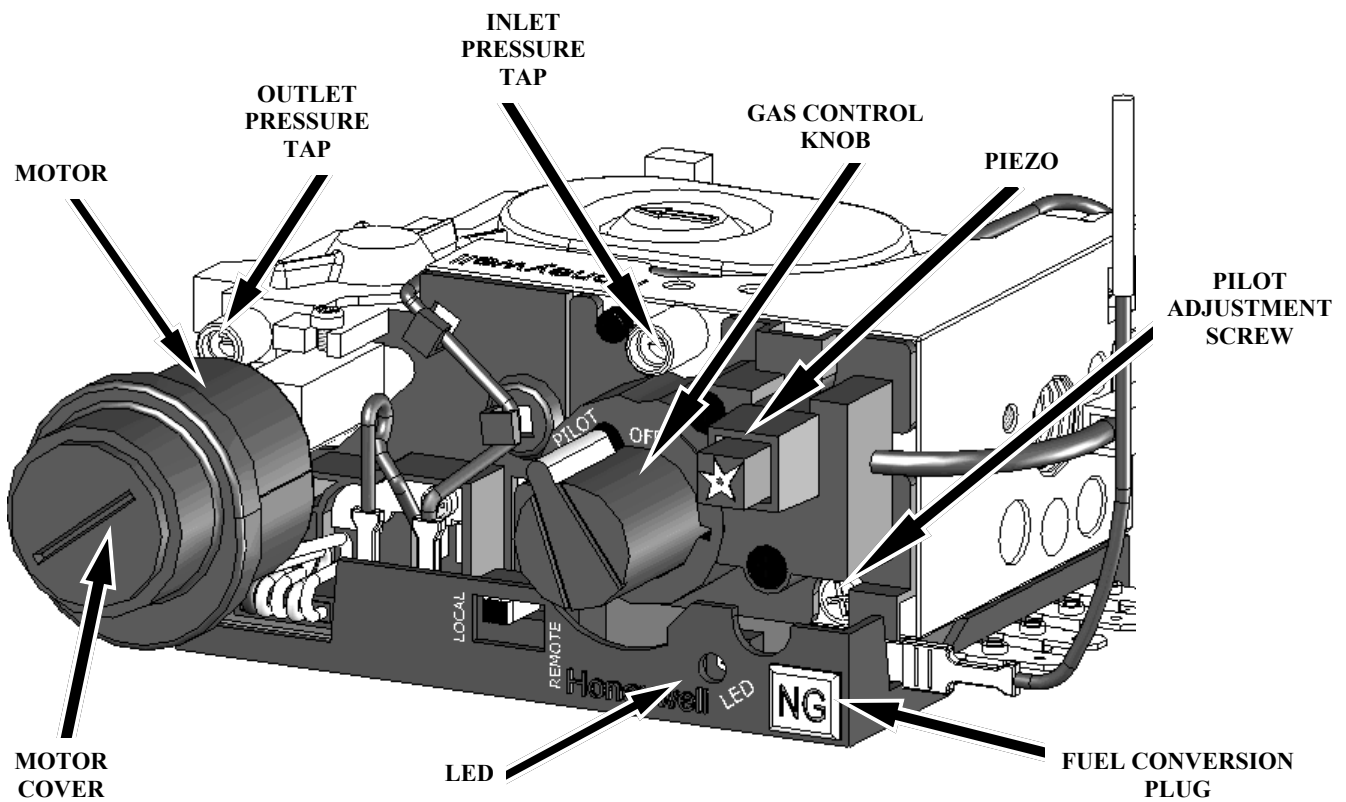

**RF VALVE (bottom view)**

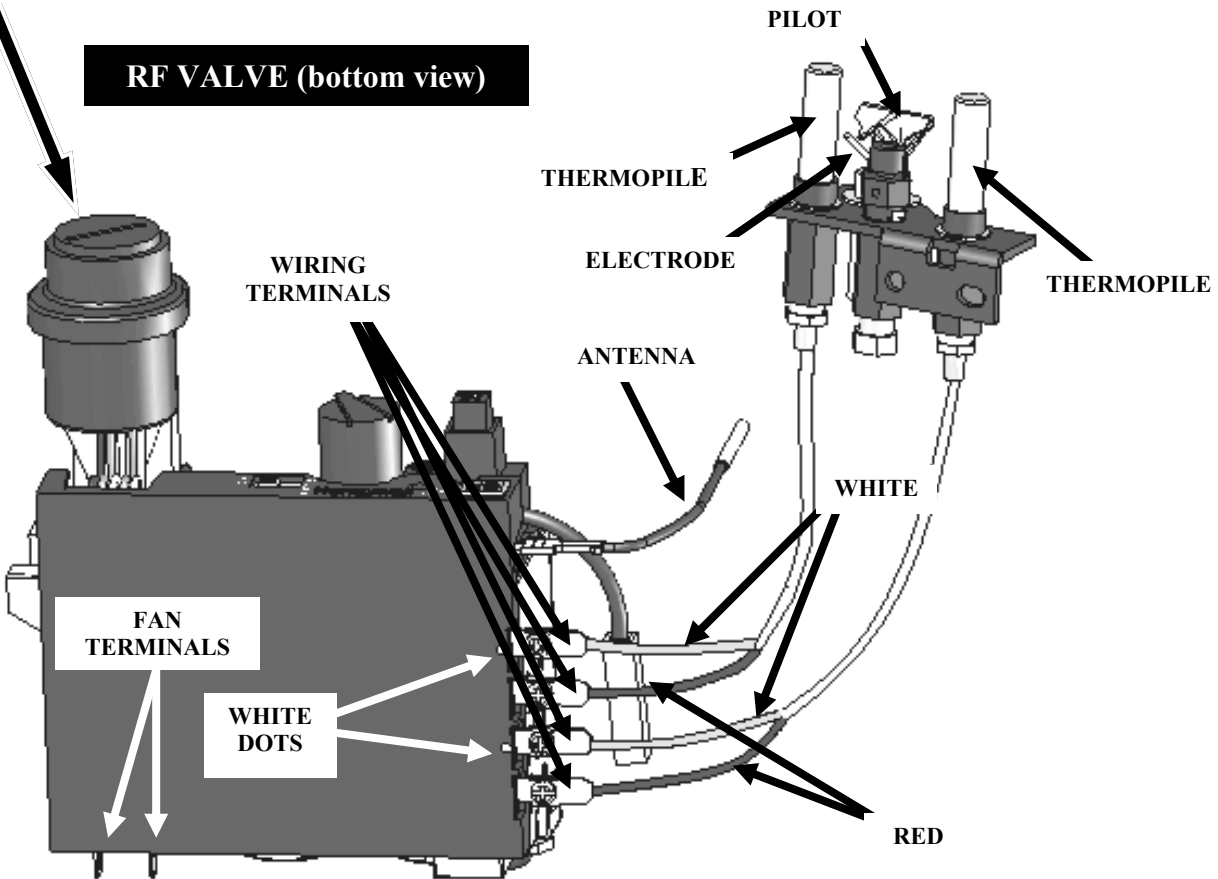

# CSK-31-RF LIGHTING AND SHUTDOWN

**FOR YOUR SAFETY - READ BEFORE LIGHTING**



**WARNING: IF YOU DO NOT FOLLOW THESE INSTRUCTIONS EXACTLY, A FIRE OR EXPLOSION MAY RESULT, CAUSING PROPERTY DAMAGE, PERSONAL INJURY OR LOSS OF LIFE.**

**DUE TO HIGH SURFACE TEMPERATURES, KEEP CHILDREN, CLOTHING AND FURNITURE AWAY.**

This appliance needs fresh air for safe operation and must be installed so there are provisions for adequate combustion and ventilation air.

1. This appliance has a pilot which must be lighted by hand. When lighting the pilot, follow these instructions exactly.
2. **BEFORE LIGHTING**, smell all around the appliance for gas. Be sure to smell next to the floor because some gas is heavier than air and will settle on the floor.
3. Use only your hand to push in or turn the gas control knob. Never use tools. If the knob will not push in, or turn by hand, do not try to repair it, call a qualified service technician. Forced or attempted repair may result in a fire or explosion, and loss of warranty.
4. Do not use this appliance if any part has been under water. Immediately call a qualified service technician to inspect the appliance and to replace any part of the control system which has been under water.



**DO NOT STORE OR USE GASOLINE OR OTHER FLAMMABLE VAPORS AND LIQUIDS IN THE VICINITY OF THIS OR ANY OTHER APPLIANCE.**

## **WHAT TO DO IF YOU SMELL GAS:**

- \* Do not touch any electrical switches
- \* Do not try to light any appliance
- \* Do not use the phone in your building
- \* Immediately call your gas supplier from a neighbor's phone
- \* Follow the gas supplier's instructions
- \* If you cannot reach your gas supplier, call the fire department

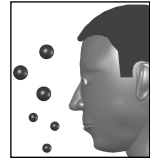

**WARNING: CHILDREN AND ADULTS SHOULD BE ALERTED TO THE HAZARDS OF HIGH SURFACE TEMPERATURES AND SHOULD STAY AWAY TO AVOID BURNS OR CLOTHING IGNITION. YOUNG CHILDREN SHOULD BE CAREFULLY SUPERVISED WHEN THEY ARE IN THE SAME ROOM AS THE APPLIANCE. CLOTHING OR OTHER FLAMMABLE MATERIAL MUST NOT BE PLACED ON OR NEAR THE APPLIANCE.**



**NOTE: A PAINT SMELL WILL OCCUR DURING THE FIRST FEW HOURS OF BURNING. IT IS RECOMMENDED TO LEAVE THE FAN OFF DURING THIS PERIOD TO HELP SPEED THE PAINT CURING PROCESS.**

**NOTE: THIS FIREPLACE MAY PRODUCE NOISES OF VARYING DEGREE AS IT HEATS AND COOLS DUE TO METAL EXPANSION AND CONTRACTION. THIS IS NORMAL AND DOES NOT AFFECT THE PERFORMANCE OR LONGEVITY OF THE FIREPLACE.**

# CSK-31-RF LIGHTING AND SHUTDOWN (cont.)

## LIGHTING

1. Turn off all electrical power to the appliance. (Fan).
2. Open lower grill to access the gas valve & controls.

5 MINUTES

- A. Push control knob in slightly and turn clockwise to the **OFF** position. Wait five (5) minutes to clear out any gas. If you then smell gas, **STOP!** Follow the safety information on the previous page and on the front cover of this installation manual. If you don't smell gas, go to the next step.

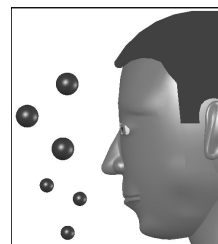
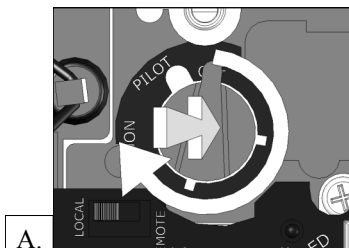

- B. Locate pilot. The pilot is located inside the combustion chamber.

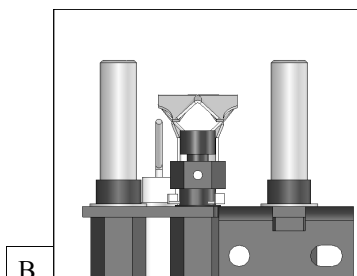

- C. Push the control knob on the gas valve in slightly and turn counterclockwise to **PILOT**. Push the control knob all the way in and hold. Push the plunger on the piezo ignitor until the pilot is lit. The pilot will generally light within two or three pushes on the piezo ignitor. Hold the knob for about one (1) minute after the pilot is lit. Release knob and it will pop back out. Pilot should remain lit. If it goes out, repeat steps A-C.

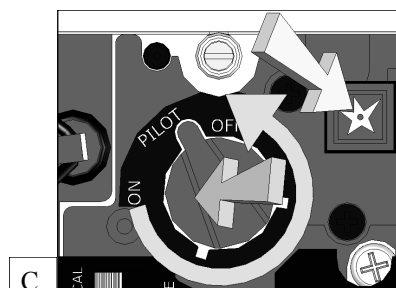

1 MINUTE



**CAUTION:** If knob does not pop up when released, stop and immediately call your service technician or the gas supplier. If the pilot will not stay lit after several tries, turn the gas control knob to OFF and call your service technician or the gas supplier.

**NOTE:** Gas control knob cannot be turned from "PILOT" to "OFF" unless knob is pushed in slightly. Do not force.

- D. Push the control knob on the gas valve in slightly and turn counterclockwise to the **ON** position.

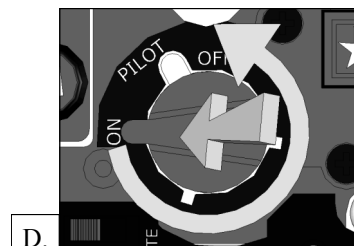

**NOTE:** If the manual switch is in the LOCAL position, the main burner will turn on immediately.

**NOTE:** When the fireplace is initially lit, condensation will appear on the glass; this is normal in all gas fireplaces and will disappear after several minutes.



# CSK-31-RF LIGHTING AND SHUTDOWN (cont.)

## INITIAL USE OF TRANSMITTER



### IMPORTANT:

On the initial use of the transmitter, a recognition operation is required between the receiver / valve and the transmitter.

1. Turn gas control knob to the **PILOT** position. Move **LOCAL / REMOTE** switch to the **LOCAL** position for at least two (2) seconds, then move switch to the **REMOTE** position.

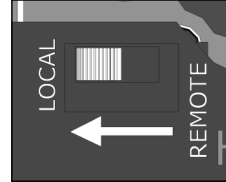
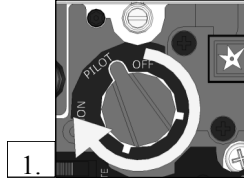

2 SECONDS

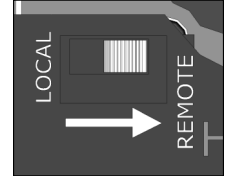

2. Press **FAN** or **FLAME** button on the transmitter within thirty (30) seconds of the switch change.

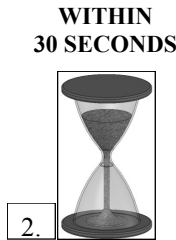

PRESS

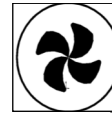

OR

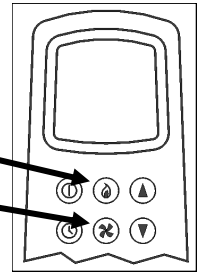

3. Turn gas control knob to the **ON** position.

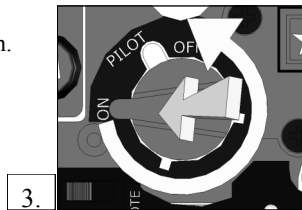

The **LED** will blink, indicating that the transmitter will now work with the receiver / valve. If the switch stays in the **REMOTE** position, the TR8220A Transmitter will control the main valve, flame modulation level and fan control.

If the **LOCAL / REMOTE** switch is in the **LOCAL** position, the receiver / valve will be at the highest setting.



## TURN THE BURNER OFF

**LOCAL SETTING:** Turn control knob clockwise to the **PILOT** position.

**REMOTE SETTING:** The TR8220A transmitter can shut off the main burner and fan. However, the control is still 'ON' and a command from the transmitter can turn on the main burner and fan.

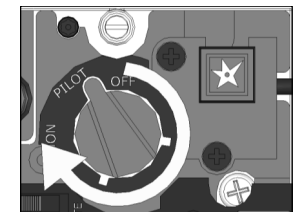

## TURN THE SYSTEM OFF

1. Open lower grill to access the gas valve & controls.
2. Turn gas control knob clockwise to the **OFF** position. This closes the main gas and safety valves. The transmitter cannot turn on the main burner or the fan.



**NOTE:** If the manual switch is in the **LOCAL** position, the main burner will turn on immediately.



**NOTE:** This control valve has an interlock device. If pilot has been turned off, it cannot be relit until the thermocouple has cooled, (approximately 60 seconds).

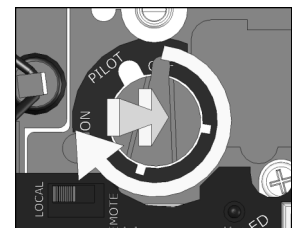

# PRESSURE TESTING (CSK-31-RF)



**IMPORTANT NOTICE:** Pressure check taps for the manifold (outgoing) and inlet (incoming) pressure have been incorporated into the valve. The pressure tap marked 'OUT' measures outgoing pressure and the pressure tap marked 'IN' measures incoming pressure. Follow instructions below for proper testing procedures.



**NOTE:** The appliance and its individual shutoff valve must be disconnected from the gas supply piping system during any pressure testing of that system at pressures in excess of ½ psi.

**NOTE:** The appliance must be isolated from the gas supply piping system by closing its individual manual shut-off valve during any pressure testing of the gas line at test pressures equal to or less than ½ psi (3.5 kPa).

## INLET PRESSURE TEST:

1. Loosen inlet ('IN') pressure tap screw (counter-clockwise).
2. Attach manometer using a 1/4" I.D. hose.
3. Light pilot.
4. Turn gas control knob to 'ON'. Note manometer reading.
5. Turn gas control knob to 'OFF'.
6. Disconnect hose and tighten screw (clockwise). Screw should be snug, do not over tighten.
9. Relight pilot and turn gas control knob to 'ON'. Reattach manometer to inlet pressure tap to verify that it is completely sealed.



**NOTE:** If inlet pressure reading is too high or too low, contact the gas company. Only a qualified gas service technician should adjust the incoming gas pressure.

## MANIFOLD PRESSURE TEST:

1. Light pilot.
2. Loosen manifold ('OUT') pressure tap screw (counter-clockwise).
3. Attach manometer to pressure tap using a 1/4" I.D. hose.
4. Turn gas control knob to 'ON'. Note manometer reading.
5. Disconnect manometer hose and tighten screw (clockwise). Screw should be snug, do not over tighten.
6. Attach manometer to manifold pressure tap to verify that it is completely sealed. Manometer should read no pressure.



**CAUTION:** A LOW PRESSURE READING CAN CAUSE DELAYED IGNITION

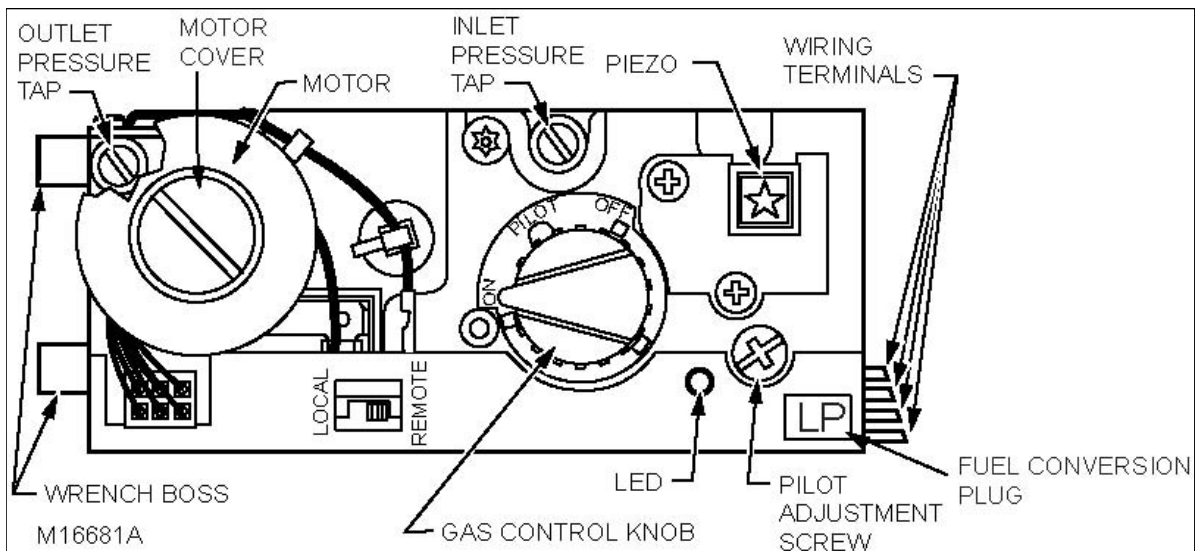

# CSK-31-RF REMOTE RECEIVER FUNCTIONS



**IMPORTANT: PLEASE REVIEW AND RETAIN INSTRUCTIONS INCLUDED WITH THE RF TRANSMITTER. IT PROVIDES ADDITIONAL INFORMATION AND DETAILS CONCERNING OPERATIONAL PROCEDURES AND FUNCTIONS FOR THE RF REMOTE CONTROL.**

## FUNCTIONS:

- Flame powered system.
- Flame powered flame modulation.
- Electronics integrated into valve to provide thermostat, flame, and fan functions with RF commands.
- Temperature compensated RF receiver.
- Main burner runs on 'HIGH' when manual switch is set to 'LOCAL'.

## TRANSMITTER SIGNAL:

- When transmitter is in Auto mode, a signal is sent every 10 minutes if there is a change in room temperature.
- When transmitter is in 'ON' or 'OFF' modes, a signal is sent every 10 minutes with the 'ON' or 'OFF' status condition.
- Make sure antennae is not touching metal.

## RECEIVER SHUTDOWN OF BURNER:

- In the remote 'AUTO' mode, the valve shuts off if it does not receive a signal within 3 hours from the transmitter.
- In the 'LOCAL' mode, the valve does not shut off.
- In the remote 'MANUAL' mode, the valve shuts off if it does not receive a signal within 6 hours from the transmitter.

## THERMOPILES:

- The negative leads (white) must be connected to the terminals marked with white dots.

## LED TROUBLESHOOTING:

- In normal operation, LED blinks once every two seconds; also, LED will be on for one second after every valid command received by the RV83110D; these are not error codes.
- Failure codes (see table) can occur anytime after the pilot burner is lit. Failure code timing is 1/4 second on, 1/2 second off.
- Sequence is failure code followed by LED not blinking for four seconds.
- In the event of multiple failure codes, the next failure code follows the previous code failure by approximately three seconds.

Code	Service Action
8	Replace valve
7	Confirm stepper motor connection exists
4	Fuel conversion plug missing or has poor connection (RV8310E only)
3	Replace thermopile with Q313
2	Device too hot. Check application
1	None required. This is normal operation and indicates the control is powered

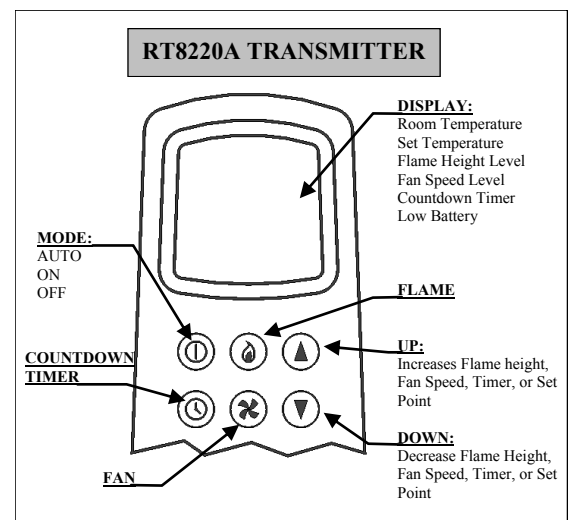

# CSK-31-RF REMOTE RECEIVER FUNCTIONS (cont.)

## FIRST USE OF TRANSMITTER:

<u>STATUS</u>		<u>ACTION</u>
Begin communication between transmitter and receiver / valve.		Move LOCAL/REMOTE Switch to LOCAL position for at least two seconds; then move switch to the REMOTE position.
Transmit unique code.		Press Fan or Flame key within 30 seconds.
Confirm recognition between transmitter and receiver valve.		Observe LED turns on for one second.
Chose REMOTE or LOCAL operation.		Move LOCAL/REMOTE switch to LOCAL or leave in REMOTE.

## OPERATION IN THE REMOTE POSITION:

### AUTO Mode

With the control in the AUTO mode, the flame in the main burner will turn on, off, or change height based on the heat needed to maintain the set temperature.

<u>STATUS</u>		<u>ACTION</u>
Set to AUTO.		Press MODE button until mode is AUTO.
Change set temperature.		Press UP or DOWN key to change temperature.
Flame.		Automatically changes.
Fan.		Automatically changes.
To set Delay Timer.		Press TIME key followed by either UP or DOWN arrow key.



**CAUTION: PROPERTY DAMAGE HAZARD. Excessive heat can cause property damage. In AUTO Mode, the main burner will cycle indefinitely to maintain the set temperature. Keep the transmitter in a heated living space to make sure the main burner is not on continuously.**

### ON Mode

With the control in the ON mode, the flame and fan levels and the delay timer are changed with the UP and DOWN arrow keys.

<u>STATUS</u>		<u>ACTION</u>
Set to ON.		Press MODE button until mode is ON.
Flame.		Press FLAME button and press UP or DOWN arrow keys to change flame height.
Fan.		Press FAN button and press UP or DOWN arrow keys to change fan speed.
Delay Time.		Press DELAY TIMER button and press UP or DOWN key to change timer.
<b>OFF Mode</b> The flame in the main burner will turn off and the room temperature will be displayed in the remote window.		Press MODE until mode is OFF.

**Operation in the LOCAL Mode. NOTE:** Remote/Local switch on the receiver/valve must be in the LOCAL position.

<b>FAN</b> Flame height and fan speed both go to the highest position.		In LOCAL mode, to turn fan ON/OFF, rotate manual knob from ON to PILOT position.
---	--	--

## OTHER FUNCTIONS:

Change between Fahrenheit and Celsius temperature units.		Press UP and DOWN arrow keys at the same time and hold for at least three seconds.
Fan override during AUTO Mode.		Press FAN button, and press UP or DOWN arrow key to change the fan speed.
Disable/enable thermostat function in the AUTO Mode.		Press the TIME, DOWN and FLAME arrow keys at the same time and hold for at least three seconds.

# FINALIZING THE INSTALLATION

## FLAME APPEARANCE:

Flame appearance is affected by several factors including altitude, venting configuration and fuel quality. Although the venturi setting has been factory set, adjustments may be necessary for optimal performance and visual aesthetics.

When fireplace is first lit, the flames will be blue. The flames will gradually turn yellowish-orange during the first 15 minutes of operation. If the flames remain blue or the flames become dark orange with evidence of sooting (black tips), the burner tube venturi may need to be adjusted.



**WARNING: BURNER TUBE ADJUSTABLE VENTURI POSITIONING SHOULD ONLY BE PERFORMED BY A QUALIFIED PROFESSIONAL SERVICE TECHNICIAN.**

**WARNING: TO AVOID PROPERTY DAMAGE OR PERSONAL INJURY, ALLOW FIREPLACE AMPLE TIME TO COOL BEFORE MAKING ANY ADJUSTMENTS.**

### FACTORY SET BURNER TUBE VENTURI SETTINGS (ADJUST AS NECESSARY FOR YOUR INSTALLATION)

NATURAL GAS	LP (PROPANE) GAS
1/8" (3 mm) OPEN	1/2" (13 mm) OPEN

### BURNER TUBE VENTURI ADJUSTMENT GUIDELINES

VENTURI POSITION	FLAME COLOR	VENTURI ADJUSTMENT
Closed too far	Dark orange flame with black tips	Open venturi setting slightly
Open too far	Blue flames	Close venturi setting slightly



**NOTE: IF SOOT IS PRESENT, CHECK LOG POSITIONING BEFORE ADJUSTING BURNER VENTURI. LOGS MUST NOT BLOCK BURNER PORTS.**



**IMPORTANT: SLIGHT ADJUSTMENTS TO THE BURNER VENTURI OPENING CREATE DRAMATIC RESULTS. ADJUST AT SLIGHT INCREMENTS UNTIL DESIRED LOOK IS ACHIEVED. ALWAYS BURN FIREPLACE FOR AT LEAST 15 MINUTES AND ALLOW TIME TO COOL BEFORE MAKING ANY FURTHER ADJUSTMENTS.**

## TO ADJUST VENTURI:

1. Remove glass frame assembly. Refer to page 13.
2. Remove log set.
3. Remove burner assembly.
4. Loosen screw on burner venturi and adjust as necessary. Tighten screw.
5. Reinstall all components previously removed.
6. Light fireplace and wait 15 minutes before determining if any further adjustments are needed.

**BURNER VENTURI**

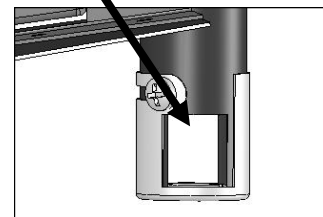

# MAINTENANCE

The appliance is required to be inspected at least once a year by a professional service person.

The compartment below the firebox (behind the lower grill) must be cleaned at least once a year, more frequent cleaning may be required due to excessive lint from carpeting, bedding materials, or other fibrous materials. It is imperative that the burner be cleaned once a year.



**NOTE: INSTALLATION AND REPAIR SHOULD BE DONE ONLY BY A QUALIFIED SERVICE PERSON. THE APPLIANCE SHOULD BE INSPECTED BEFORE USE AND ANNUALLY BY A QUALIFIED SERVICE PERSON. MORE FREQUENT CLEANING MAY BE REQUIRED DUE TO EXCESSIVE LINT FROM CARPETING, BEDDING MATERIALS, ETC. IT IS IMPERATIVE THAT CONTROL COMPARTMENTS, BURNERS AND CIRCULATION AIR PASSAGEWAYS OF THE APPLIANCE BE KEPT CLEAN.**

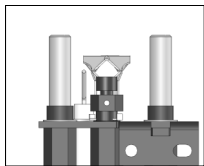

CSK-31-RF Pilot

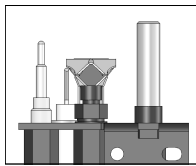

CSK-31 Pilot

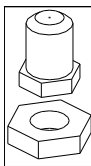

Burner Orifice

## FAN

The fan should be disconnected from electrical current, and cleaned (vacuumed) every six months. The bearings are sealed and require no oiling.

## VENT SYSTEM

Annual examination of the venting system by a qualified agency is required.

**IF THE VENT-AIR INTAKE SYSTEM IS DISASSEMBLED FOR ANY REASON, RE-INSTALL PER THE INSTRUCTIONS PROVIDED WITH THE INITIAL INSTALLATION.**

The flow of combustion and ventilation air must not be obstructed.



**IMPORTANT: ANY SAFETY SCREEN OR GUARD REMOVED FOR SERVICING MUST BE REPLACED PRIOR TO OPERATING THE APPLIANCE.**



**CAUTION: LABEL ALL WIRES PRIOR TO DISCONNECTION WHEN SERVICING CONTROLS. WIRING ERRORS CAN CAUSE IMPROPER AND DANGEROUS OPERATION. VERIFY PROPER OPERATION AFTER SERVICING.**



**CAUTION: KEEP THE APPLIANCE AREA CLEAR OF COMBUSTIBLE MATERIALS, SUCH AS GASOLINE AND OTHER FLAMMABLE VAPORS AND LIQUIDS.**

## MILLIVOLT BOARD SYSTEM

- Annual cleaning of the burner system is required.
- The burner assembly may be removed for easier access. Refer to pages 22-23 in this installation manual for complete instruction on removing & reinstalling the burner assembly.
- Visually check for blocked port holes, especially near the pilot. Blocked port holes may cause delayed ignition.
- Reinstall the burner assembly following instructions on page 23 of this installation manual.
- Visually check pilot light and burner when in operation. The flames should be steady, not lifting or floating.

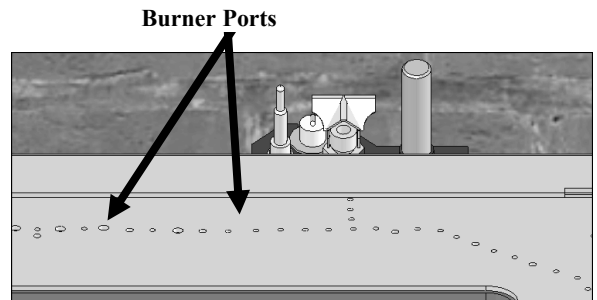

## GLASS CLEANING & REPLACEMENT

- Clean glass only when cool and only with non-abrasive cleansers.
- Do not operate this fireplace with the glass/frame assembly removed, cracked or broken.
- The glass assembly, part #CSK-057T, shall only be replaced as a complete unit, as supplied by Hussong Mfg. Co., Inc.
- Replacement of the glass & frame assembly, part #CSK-057T, must only be performed by a licensed or qualified service person. **DO NOT SUBSTITUTE MATERIALS.**
- Do not strike or slam glass door assembly.

# TROUBLESHOOTING (CSK-31 only)



CAUTION: THE FOLLOWING MUST BE PERFORMED BY A QUALIFIED TECHNICIAN.

## NO SPARK FROM ELECTRODE TO PILOT WHEN PIEZO BUTTON IS TRIGGERED.

- A. Check wiring at back of piezo for proper connection.
- B. Check wiring at electrode for proper connection.
- C. Check position of electrode (1/8" (3 mm) between electrode and pilot). Readjust if necessary.
- D. Look for arc below electrode and along electrode wire. Direct metal contact may cause an arc below electrode.

## SPARK IGNITOR WILL NOT LIGHT AFTER REPEATED TRIGGERING OF PIEZO BUTTON.

- A. No gas or low gas pressure.
  - ◆ Check remote shut off valves from fireplace. Usually there is a valve near the main. There may be more than (1) valve between the fireplace and the main.
  - ◆ Low gas pressure can be caused by several situations such as a bent line, too narrow diameter pipe, or low line pressure. Consult with plumber or gas supplier.
- B. No LP in tank.
  - ◆ Check LP (propane) tank. Refill if necessary.

## PILOT WILL NOT STAY LIT AFTER CAREFULLY FOLLOWING LIGHTING INSTRUCTIONS.

- A. Check that pilot flame impinges on thermocouple. Clean and / or adjust pilot for maximum flame impingement.
- B. Ensure the thermocouple connection at gas valve is fully inserted and tight (hand tight plus 1/4 turn).
- C. Thermocouple reading below 15 millivolts.
  - ◆ Disconnect thermocouple from valve, place one millivolt meter lead wire on the end of the thermocouple and the other millivolt meter lead wire on the thermocouple's copper wire. Start pilot while holding valve knob in. If the millivolt reading is less than 15 millivolts, replace the thermocouple.
- D. Thermopile not generating sufficient millivolts.
  - ◆ Pilot flame must be enveloping thermopile. Adjust pilot flame if necessary.
  - ◆ Check thermopile wire connections at valve. Tighten if necessary.
  - ◆ Check thermopile with millivolt meter. Turn remote / thermostat / wall switch or ON/OFF switch to OFF. Turn valve knob to PILOT position (pilot should remain lit). Take reading at THTP & TP terminals on gas valve. Reading should be 350 millivolts minimum. Replace thermopile if reading falls below specified minimum.

# TROUBLESHOOTING (CSK-31 only)

## BURNER WILL NOT LIGHT

- A. Gas control knob not turned to 'ON'.
- B. 'ON'/'OFF' switch not turned on.
- C. Remote, wall switch or thermostat not turned 'ON'.
- D. Plugged main burner orifice.
- E. Remote, wall switch ,thermostat or 'ON/ OFF' switch wires defective.
  - ◆ Check wires for proper connections. Place jumper wires across terminal at switch. If burner lights, replace defective switch.
  - ◆ If switch checks ok, place jumper wires across switch wires on gas valve. If burner lights, wires are faulty or connections are bad.

## FREQUENT PILOT OUTAGES

- A. Pilot shield not installed.
- B. Pilot flame too high or too low, causing pilot safety to drop out.
  - ◆ Clean and adjust flame for maximum flame impingement on thermopile.

## BURNER WON'T STAY LIT

- A. Thermopile wires loose at valve terminals.
  - ◆ Tighten if necessary.
- B. Thermopile wires ground out due to pinched wires.
  - ◆ Free pinched wires if necessary.
- C. Refractory panel placement (if installed).
  - ◆ Refractory panels must be tight against firebox walls. It may be necessary to secure panels with high-temp sealant, especially around the intake duct.



# TROUBLESHOOTING (CSK-31 only)

## PILOT AND BURNER EXTINGUISH WHILE IN OPERATION

### A. No LP (propane) in tank.

- ◆ Check tank and refill if necessary.

### B. Glass frame assembly not installed correctly.

- ◆ Refer to page 13 in this manual for proper glass frame assembly installment instructions.

### C. Defective thermopile or thermocouple.

- ◆ Check thermopile and thermocouple for proper millivolts.

### D. Improper pitch on horizontal vent.

- ◆ 1/4" (6 mm) rise per foot is required on horizontal venting.

### E. Inner vent pipe leaking exhaust gases back into firebox.

- ◆ Check for leaks. Repair if necessary.

### F. Improper vent cap installation.

- ◆ Check for proper vent cap installation. Maximum downward slope of horizontal vent cap is 1/4" (6 mm). Adjust if necessary.
- ◆ Check vent cap for blockage. Remove debris if necessary.

### G. Excessive draft.

## GLASS SOOTING

### A. Improper log placement.

- ◆ Refer to log placement instructions on page 21 of this installation manual.

### B. Improper venturi setting.

- ◆ Venturi may need to be opened slightly to allow more air into the gas mix.

### C. Improper pitch on horizontal venting.

- ◆ 1/4" (6 mm) rise per foot is required on horizontal venting.

## FLAME BURNS BLUE AND LIFTS OFF BURNER

### A. Improper Venturi setting.

- ◆ Venturi may need to be closed slightly.

### B. Improper vent cap installation.

- ◆ Check for proper vent cap installation.

### C. Blockage or vent system leaks.

# RF REMOTE TROUBLESHOOTING (CSK-31-RF only)

## AUTO PATH

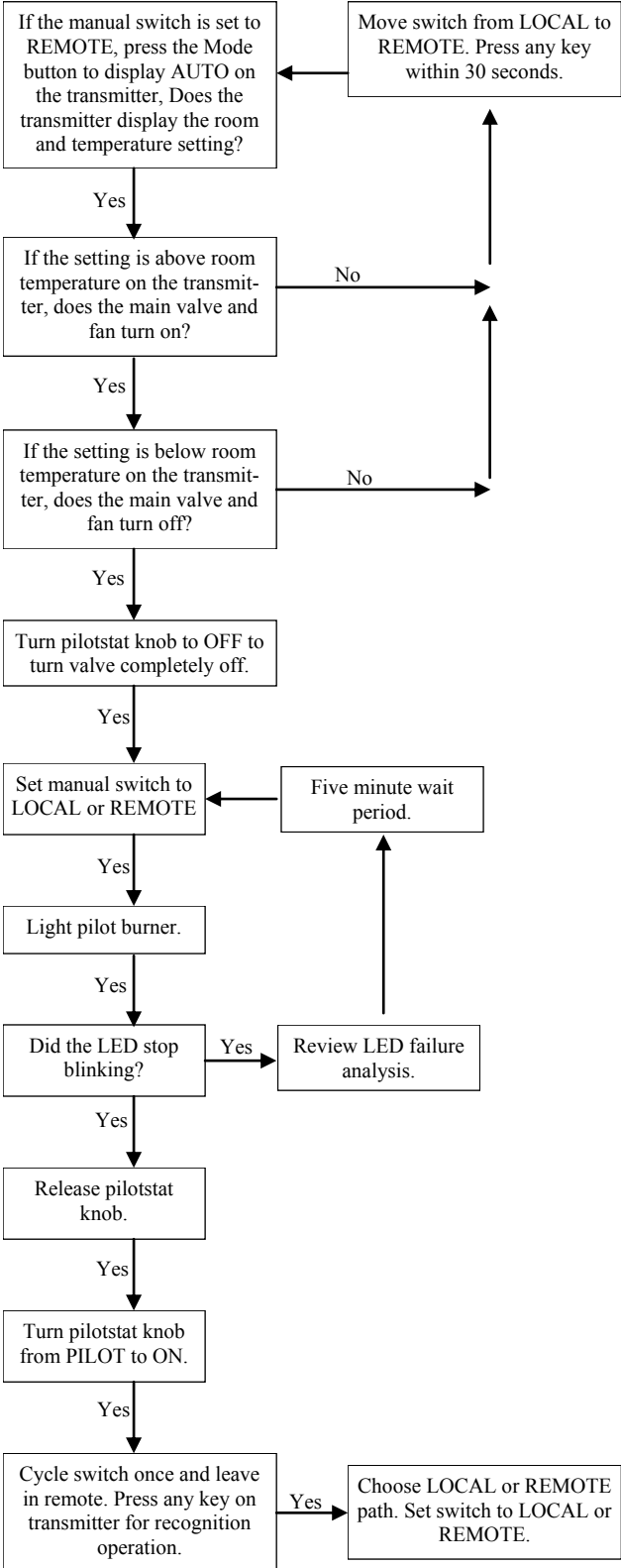

## REMOTE PATH

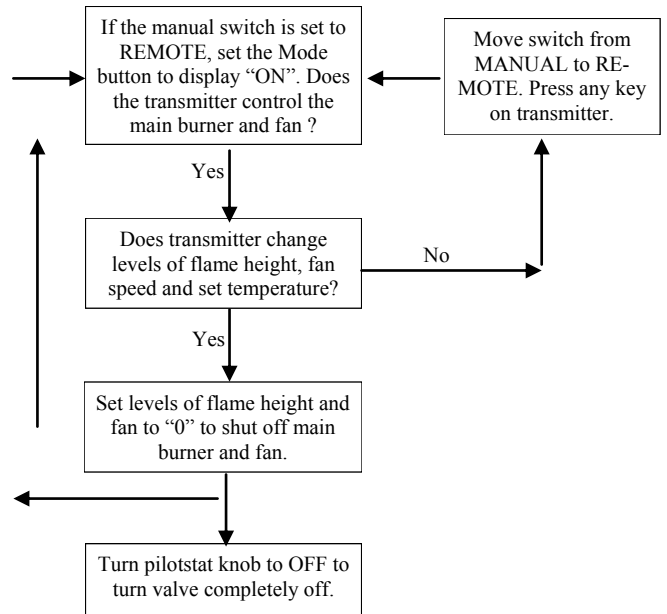

## LOCAL PATH

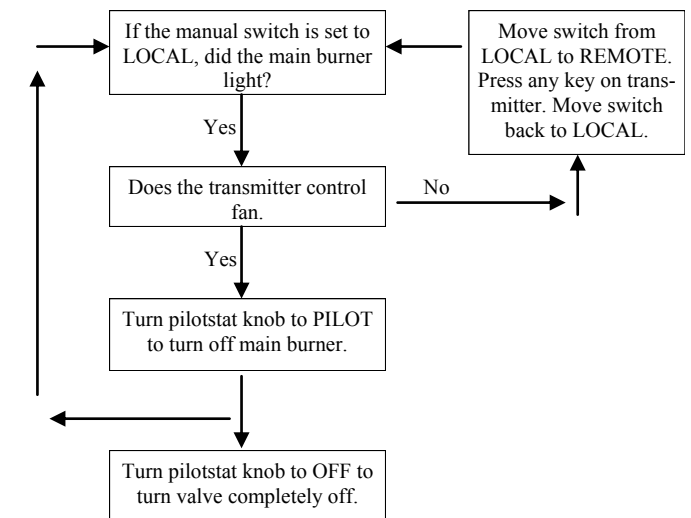

# TROUBLESHOOTING (CSK-31-RF only)



CAUTION: THE FOLLOWING MUST BE PERFORMED BY A QUALIFIED TECHNICIAN.

## NO SPARK FROM ELECTRODE TO PILOT WHEN PIEZO BUTTON IS TRIGGERED.

- A. Check piezo wiring for proper connection.
- B. Check position of electrode (1/8" (3 mm) between electrode and pilot). Readjust if necessary.
- C. Look for arc below electrode and along electrode wire. Direct metal contact may cause an arc below electrode.

## SPARK IGNITOR WILL NOT LIGHT AFTER REPEATED TRIGGERING OF PIEZO BUTTON.

- A. No gas or low gas pressure.
  - ◆ Check remote shut off valves from fireplace. Usually there is a valve near the main. There may be more than (1) valve between the fireplace and the main.
  - ◆ Low gas pressure can be caused by several situations such as a bent line, too narrow diameter pipe, or low line pressure. Consult with plumber or gas supplier.
- B. No LP in tank.
  - ◆ Check LP (propane) tank. Refill if necessary.

## PILOT WILL NOT STAY LIT AFTER CAREFULLY FOLLOWING LIGHTING INSTRUCTIONS.

- A. Check that pilot flame impinges on thermopiles. Clean and / or adjust pilot for maximum flame impingement.
- B. Ensure the thermopile connections at gas valve are properly connected. The negative leads ( white) must be connected to the terminals with the one white dot next to them.

## BURNER WILL NOT LIGHT

- A. Gas control knob not turned to 'ON'.
- B. Plugged main burner orifice.

## FREQUENT PILOT OUTAGES

- A. Pilot shield not installed.
- B. Pilot flame too high or too low, causing pilot safety to drop out.
  - ◆ Clean and adjust flame for maximum flame impingement on thermopiles.

## FLAME BURNS BLUE AND LIFTS OFF BURNER

- A. Improper Venturi setting.
  - ◆ Venturi may need to be closed slightly.
- B. Improper vent cap installation.
  - ◆ Check for proper vent cap installation.
- C. Blockage or vent system leaks.

# TROUBLESHOOTING (CSK-31-RF only)

## BURNER WON'T STAY LIT

### A. Thermopile wires loose at valve terminals.

- ◆ Adjust if necessary.

### B. Thermopile wires ground out due to pinched wires.

- ◆ Free pinched wires if necessary.

### C. Refractory panel placement (if installed).

- ◆ Refractory panels must be tight against firebox walls. It may be necessary to secure panels with high-temp sealant, especially around the intake duct.

## PILOT AND BURNER EXTINGUISH WHILE IN OPERATION

### A. No LP (propane) in tank.

- ◆ Check tank and refill if necessary.

### B. Glass frame assembly not installed correctly.

- ◆ Refer to page 13 in this manual for proper glass frame assembly installment instructions.

### C. Improper pitch on horizontal vent.

- ◆ 1/4" (6 mm) rise per foot is required on horizontal venting.

### D. Inner vent pipe leaking exhaust gases back into firebox.

- ◆ Check for leaks. Repair if necessary.

### E. Improper vent cap installation.

- ◆ Check for proper vent cap installation. Maximum downward slope of horizontal vent cap is 1/4" (6 mm). Adjust if necessary.
- ◆ Check vent cap for blockage. Remove debris if necessary.

### F. Excessive draft.

## GLASS SOOTING

### A. Improper log placement.

- ◆ Refer to log placement instructions on page 21 of this installation manual.

### B. Improper venturi setting.

- ◆ Venturi may need to be opened slightly to allow more air into the gas mix.

### C. Improper pitch on horizontal venting.

- ◆ 1/4" (6 mm) rise per foot is required on horizontal venting.

# REPLACEMENT PARTS LIST

Replacement parts are available through your local dealer. Contact them for availability and pricing.

## CSK-31 MILLIVOLT BOARD AND PARTS

CSK-770A	Millivolt Board - Nat Gas	700-094	Pilot Orifice - Natural Gas
CSK-771A	Millivolt Board - LP Gas	700-095	Pilot Orifice - LP Gas
700-023	On/Off Rocker Switch	700-098	Pilot Hood
700-086A	Valve - Natural Gas	700-203	Manual Shut-off Valve
700-087A	Valve - LP Gas	700-213-B	18" Flexible Gas Line-Black
700-063	Pilot Assembly - Nat Gas	700-226F	Flexible Gas Line-Valve to Burner Connection
700-063-I	Pilot Assembly - LP Gas	700-237	Natural Gas Orifice #37
700-090	Piezo Igniter w/ Nut (no wire)	700-252	LP Gas Orifice #52
700-060	Flexible Pilot Tubing (Valve to Pilot)	OCK-S37A	Natural Gas Conversion Kit
700-092	Millivolt Generator	OCK-S52A	LP Gas Conversion Kit
700-093	Thermocouple	CSK-135	Burner Assembly

## CSK-31 - RF MILLIVOLT BOARD AND PARTS

CSK-800RF	RF Millivolt Board - Natural Gas	700-083	Honeywell Piezo Sparker (only)
700-107	Honeywell RF Valve - Natural Gas	700-203	Manual Shut-off Valve
700-108	Remote Control - RF Valve	700-226F	Flexible Gas Line-Valve to Burner Connection
700-109	Honeywell RF Pilot Assembly-NAT	700-226F	Flexible Gas Line-Valve to Burner Connection
700-109-I	Honeywell RF Pilot Assembly-LP	700-237	Natural Gas Orifice #37
700-060	Flexible Pilot Tubing (Valve to Pilot)	700-252	LP Gas Orifice #52
700-092RF	Millivolt Generator	OCK-H37N-RF	Natural Gas Conversion Kit
700-203	Manual Shut-off Valve	OCK-H52L-RF	LP Gas Conversion Kit
700-213B	18" Flexible Gas Line - Black	CSK-135	Burner Assembly
700-213	6" Flexible Gas Line-Valve to Burner Connection	700-108	Remote Control
700-098	Pilot Hood		

## GRILL REPLACEMENT

CSK-200	Upper Hood (For 3 & 4 pc. Shrouds)
CSK-200F	Upper Hood (For Full Door Shrouds)
CSK-201	Lower Grill

## FAN ASSEMBLIES

RF-028	Fan Assembly (CSK-31-RF only)
CSK-028	Fan Assembly (CSK-31 only)

## LOG SET

CSK-50A	11 pc. Log Set
CSK-1	#C1 Log
CSK-2	#C2 Log
CSK-3	#C3 Log
CSK-4	#C4 Log
CSK-5	#C5 Log
CSK-6	#C6 Log
CSK-7	#C7 Log
CSK-8	#C8 Log
CSK-12	#C12 Log
CSK-13	#C13 Log
900-REMB	Rock Wool Embers

## REFRACTORY PANELS (Sandstone)

CSK-G900	(4 pc.) Refractory Panel Set
CSK-900B	Back Refractory Panel
CSK-G900L	Left Side Refractory
CSK-900R	Right Side Refractory
CSK-G902	Top Refractory Panel

## GLASS & GLASS GASKET

CSK-005	Replacement Valance
900-006	1-1/8" Glass Gasket w/ Adhesive
CSK-057T	Valance with 14-1/4" x 29" glass

\*Consult your dealer for information on optional accessories available for this fireplace.

This appliance tested & certified by:  
OMNI - Test Laboratories, Inc.  
13327 NE Airport Way  
Portland, Oregon 97230

Model #CSK-31 Chaska  
Model #CSK-31-RF Chaska-RF  
April 2009-REV08

[www.kozyheat.com](http://www.kozyheat.com)

Manufactured by:

Hussong Mfg. Co., Inc.  
204 Industrial Park Drive  
Lakefield, Minnesota 56150  
507-662-6641

**KOZY HEAT  
LIMITED 10 YEAR WARRANTY**

*Effective July 01, 2003*

This Limited 10 Year Warranty will not become effective until the warranty registration form has been completed and mailed to Hussong Manufacturing Co., Inc., P.O. Box 577, Lakefield, MN 56150. This registration form must be received within 30 days of installation. Failure to do so may result in delayed warranty coverage and submission of proof of purchase will be required.

Hussong Manufacturing Co., Inc. warrants to the original purchaser of this Kozy Heat Fireplace, that it is free of defects in materials and workmanship at the time of manufacture.

Subject to the following conditions & requirements, Hussong Manufacturing Co., Inc. extends the following limited warranty under normal use and service, with respect to the Kozy Heat line of gas burning fireplaces.

**YEAR 1:** Subject to the conditions & requirements listed below, within the first year from date of purchase, Hussong Manufacturing Co., Inc. shall, at its discretion, replace or repair any such defect in material or workmanship, at Hussong Manufacturing Co., Inc.'s expense, including reasonable labor costs to repair or replace the defective component, if a factory pre-authorization is given for the repair.

**YEARS 2 - 10:** Subject to the conditions & requirements listed below, beginning with the first day of the second year and continuing through the tenth year, Hussong Manufacturing Co., Inc., will at its discretion, provide repair or replacement parts at current list prices for any defect in material or workmanship of components, including optional components and accessories (if available). Hussong Manufacturing Co., Inc. shall not be responsible for any installation, labor, transportation or other indirect costs.

**LIMITATION OF LIABILITY**

To make a claim under this warranty, the purchaser must first contact the dealer/installer from whom the fireplace was purchased.

This limited warranty will be void if the fireplace is not installed by a qualified installer and according to the installation instructions. Use of unauthorized components will make this warranty null and void.

This limited warranty also is void if the fireplace is not operated, at all times, according to the operating instructions furnished.

This warranty is limited to defects in material and workmanship. It does not apply to any product that has been subject to negligence, misapplication, improper installation. Remote control warranties are covered by Ambient Technologies, Inc., and are excluded from this Limited Warranty.

No person is authorized to extend the time of this warranty or to accept on Hussong Manufacturing Co., Inc.'s behalf any additional obligation of liability connected with the unit.

It is expressly agreed and understood that this warranty is Hussong Manufacturing Co., Inc.'s sole obligation and purchaser's exclusive remedy for defective fireplace equipment. Hussong Manufacturing Co., Inc. shall not be liable for any consequential, incidental or contingent damages whatsoever. The foregoing warranty is exclusive and in lieu of all other expressed warranties. Hussong Manufacturing Co., Inc. shall not be held to implied warranties, including but not limited to the implied warranties of merchantability and fitness for a particular purpose. This warranty replaces all previous warranty policies.

Some states do not allow the exclusion or limitation of incidental or consequential damages or limitations on how long an implied warranty lasts, so the above limitations or exclusions may not apply to you. This warranty gives you specific legal rights and you may also have other rights which vary from state to state.

Hussong Manufacturing Co., Inc. reserves the right to make changes at any time, without notice, in design, material, specifications and prices. Hussong Manufacturing Co., Inc. reserves the right to discontinue models and products.

**WARRANTY CONDITIONS & REQUIREMENTS:**

1. You are the original purchaser. This warranty is not transferable.
2. Installation of the fireplace is performed by a qualified installer.
3. Installation and operation must comply with installation and operation instructions.
4. Paint and glass gaskets are covered for 30 days from date of purchase.
5. Components broken, (including glass panels), during shipping, careless handling of components, or defects resulting from improper installation, misuse of the fireplace and components are not covered under this warranty.
6. This warranty does not cover any part of the fireplace or any components which have been exposed to or submerged under water.
7. Hussong Manufacturing Co., Inc. must be notified by the dealer the fireplace was purchased from or a qualified installer or service technician of the defect.
8. Annual service of the fireplace as required in the installation manual, is performed by a qualified installer/service technician. (Copies of such service records may be required to claim a warranty.)
9. All previous warranty/service has been performed by a qualified installer or service technician. (Copies of such service records may be required to claim a warranty.)



**LIFETIME WARRANTY**

**THIS LIFETIME WARRANTY COVERAGE WILL BE EXTENDED AS DESCRIBED BELOW PROVIDED ALL WARRANTY CONDITIONS AND REQUIREMENTS ARE MET AS OUTLINED IN THE 10 YEAR LIMITED WARRANTY POLICY.**

**LIFETIME WARRANTY COVERAGE**

LIFETIME WARRANTY IS EXTENDED AS FOLLOWS: Hussong Manufacturing warranties to the original purchaser that the firebox, heat exchanger, fiber logs, burner tube and glass of this Kozy Heat fireplace will not be defective in material or workmanship under normal use and service for as long as you own this product. If any of these components fail due to defects in material or workmanship under normal use and service, Hussong Manufacturing Co., Inc. will, at its sole discretion, repair or replace the defective component. This LIFETIME WARRANTY does not cover any installation, labor, transportation or other indirect costs arising from defective components.

**LIMITATION OF LIABILITY**

This Lifetime warranty will be void if the fireplace is not installed by a qualified installer and according to the installation instructions. Use of unauthorized components will make this warranty null and void. This lifetime warranty also is void if the fireplace is not operated, at all times, according to the operating instructions furnished. This warranty is limited to defects in material and workmanship of components specified. It does not apply to any product that has been subject to negligence, misapplication, improper installation.

No person is authorized to extend the time of this Lifetime warranty or to accept on Hussong Manufacturing Co., Inc.'s behalf any additional obligation of liability connected with the unit.

Hussong Manufacturing Co., Inc. may fully discharge all obligations with respect to this Lifetime warranty by refunding the wholesale price of the defective component(s).

It is expressly agreed and understood that this Lifetime warranty is Hussong Manufacturing Co., Inc.'s sole obligation and original purchaser's exclusive remedy for defective fireplace equipment. Hussong Manufacturing Co., Inc. shall not be liable for any consequential, incidental or contingent damages whatsoever other than those incurred by Hussong Manufacturing Co., Inc. to repair or replace the defective component. The foregoing warranty is exclusive and in lieu of all other expressed warranties. Hussong Manufacturing Co., Inc. shall not be held to implied warranties, including but not limited to the implied warranties of merchantability and fitness for a particular purpose. This lifetime warranty replaces all previous lifetime warranty policies.

Hussong Manufacturing Co., Inc. reserves the right to make changes at any time, without notice, in design, material, specifications and prices. Hussong Manufacturing Co., Inc. reserves the right to discontinue models and products.

JUNE 1998

(CUT ALONG DOTTED LINE)

**TO ACTIVATE THIS LIFETIME WARRANTY COVERAGE, THIS REGISTRATION CARD MUST BE COMPLETED AND MAILED WITH YOUR COMPLETED 10 YEAR LIMITED WARRANTY FORM WITHIN 30 DAYS OF INSTALLATION.**

**PURCHASER'S NAME:** \_\_\_\_\_

**INSTALLATION DATE:** \_\_\_\_\_

**ADDRESS:** \_\_\_\_\_  
\_\_\_\_\_

**MODEL#:** \_\_\_\_\_ **SERIAL #:** \_\_\_\_\_

**TELEPHONE #** \_\_\_\_\_

**INSTALLER NAME:** \_\_\_\_\_

**ADDRESS:** \_\_\_\_\_  
\_\_\_\_\_

**TELEPHONE #** \_\_\_\_\_