



Hydrogen Fueling Infrastructure Research and Station Technology

Dispenser Reliability 2018 DOE Annual Merit Review

Presenter: Mike Peters¹ (PI)
Nalini Menon,² Kevin Hartmann,¹ Josh Martin¹

¹ National Renewable Energy Laboratory

² Sandia National Laboratories

June 14, 2018

This presentation does not contain
any proprietary, confidential, or
otherwise restricted information.

Project ID # PD140

T I M E L I N E

- Start date: 10/1/2016
- End date: 09/30/2018*

* Project continuation and direction determined annually by DOE

B A R R I E R S

Multiyear RD&D Barriers

Technology Validation Barriers

- **D.** Lack of Hydrogen Refueling Infrastructure Performance and Availability Data
- **E. Codes and Standards** - *Validation projects will be closely coordinated with Safety, Codes and Standards*

B U D G E T

- Project funding total (FY17 + FY18):
 - **\$1,740k (NREL)**
 - **\$665k (SNL)**

P A R T N E R S

NREL

Bill Buttner, Dani Murphy, Daniel Leighton, Matt Ruple, Erin Winkler, Jerod Brewster, Sam Sprik, Danny Terlip, Owen Smith, Kevin Harrison, Phil Clark

SNL

Nalini Menon, Ethan Hecht, April Nissen, Jeff Campbell, Adriana Pavia Sanders, Bernice Mills

Dispensers are the top cause of maintenance events and downtime at retail hydrogen stations

Maintenance by Equipment Type - Retail Stations

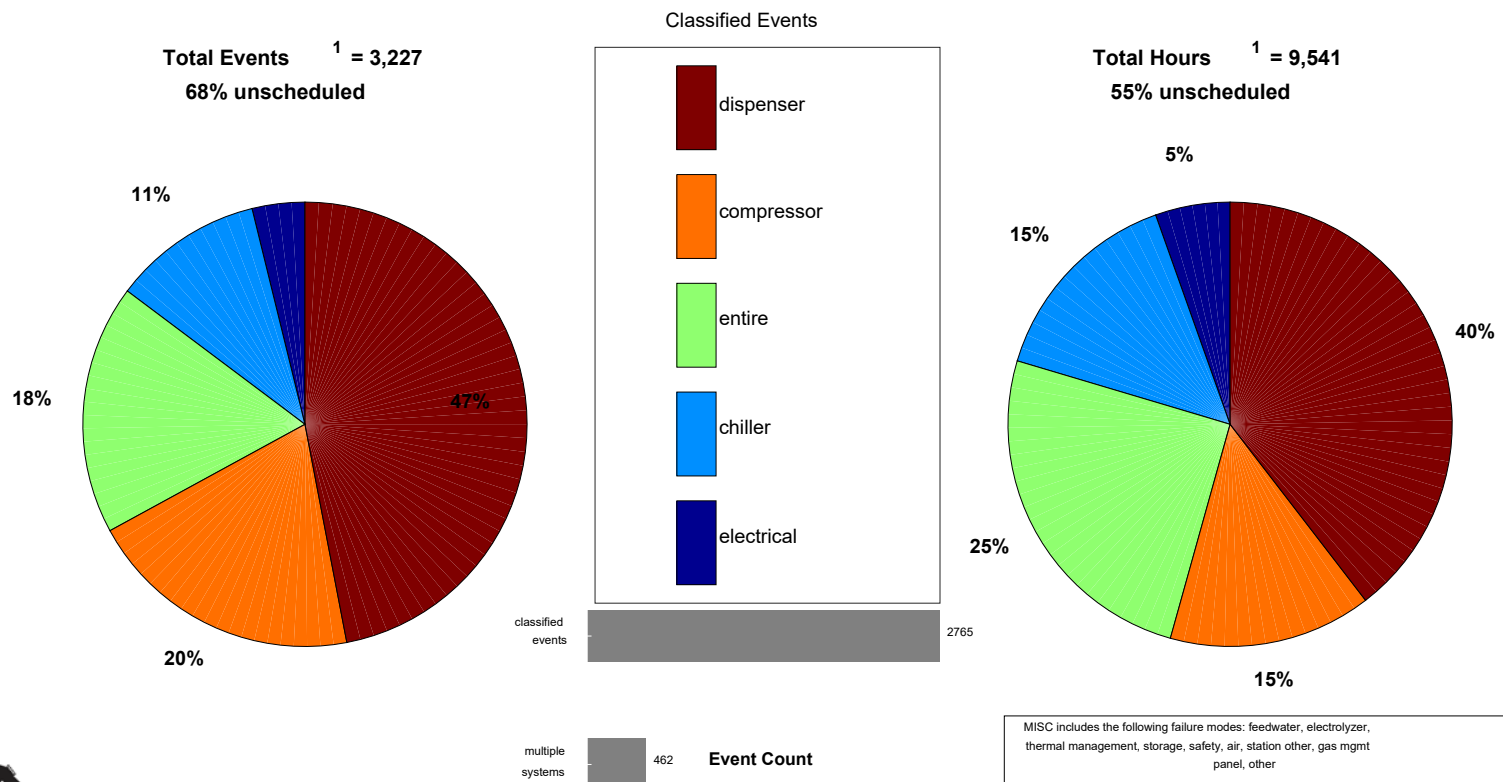

1. Total includes classified events (plotted) and unclassified events.

Relevance: Retail Station Mean H₂ Dispensed Between Failures (kg)

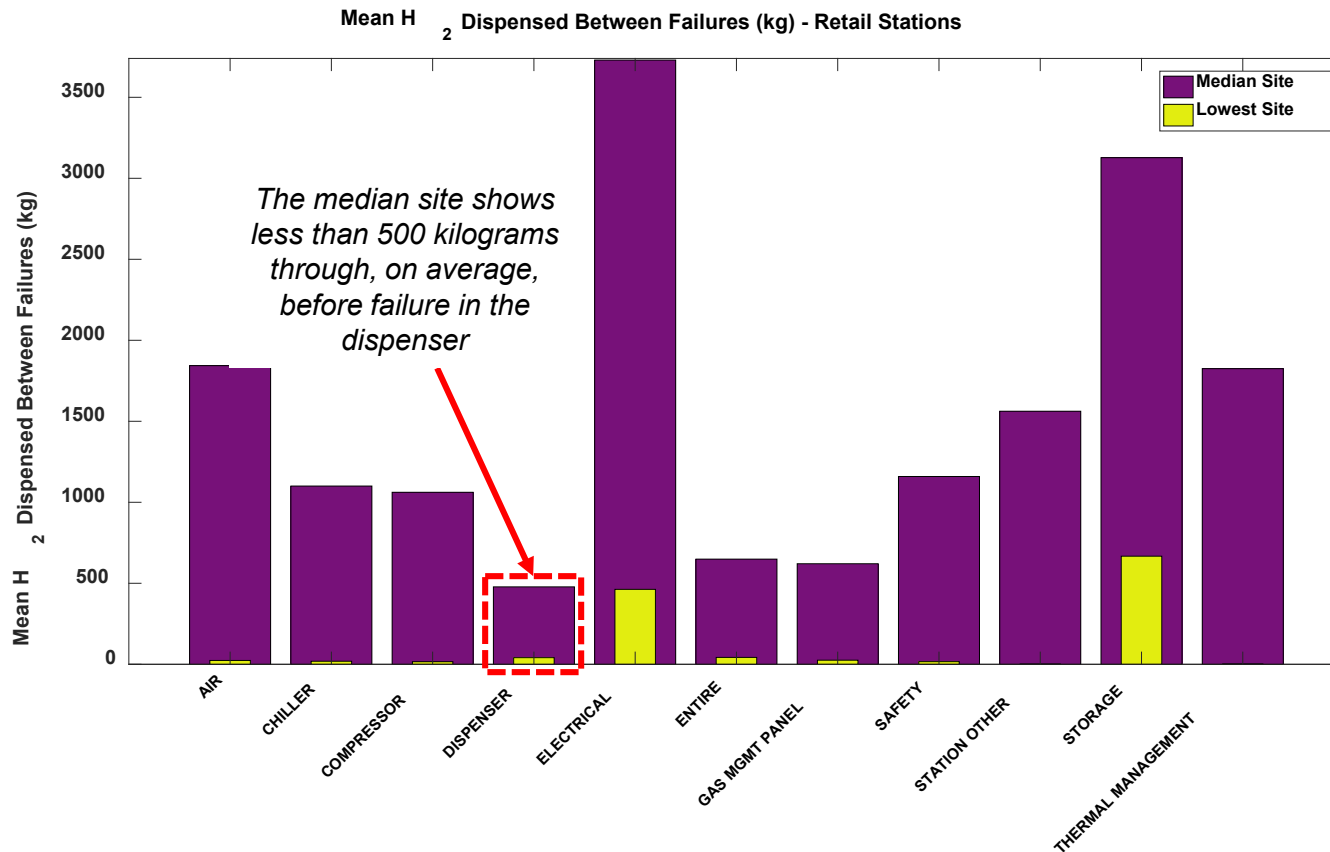

NREL cdpRETAIL_infr_51
Created: Sep-25-17 3:54 PM | Data Range: 2014Q3-2017Q2

- **Planned component testing work will have a high impact on component selection and design, fueling method evaluation, and dispenser reliability**
- There are no available data that can be leveraged to reduce the planned testing scope of this project
- There are some test campaigns on performance of piping components at the pressures and temperature in a fueling dispenser, but:
 - Available information is qualitative only, or
 - Results of specific qualification tests do not assess effects other than pass/fail

Measure the instantaneous mean fills between failures (MFBF) and instantaneous mean kilograms between failures (MKBF) of hydrogen components subjected to pressures, ramp rates, and flow rates similar to light duty fuel cell electric vehicle fueling at -40°C, -20°C, and 0°C

Device Under Test (DUT) Components in Scope

- Nozzles
- Breakaways
- Normally closed valve
- Normally open valve
- Filter

Out of Scope

- Hoses – Testing already ongoing, \$ restrictions



Leverage the National Fuel Cell Technology Evaluation Center's (NFCTEC's) station and vehicle data to define an average fill at a retail station

- Flow rate – 0.8 kg/min
- Fill time – 3.6 minutes
- Vehicle start pressure – 14.7 MPa
- Vehicle end pressure – 77.9 MPa
- Fill time + start/end pressure → 17.6 MPa/min average ramp rate

How to accelerate testing?

- Test multiple dispensers at once
- Given NREL's HITRF system capabilities, could flow through 8 dispenser-like systems simultaneously
- Systems packaged with 2 dispensers in series x 4 sets in parallel

HITRF: Hydrogen Infrastructure Testing and Research Facility

Approach: Test Setup: n = 1



 Device(s) Under Test - DUTs

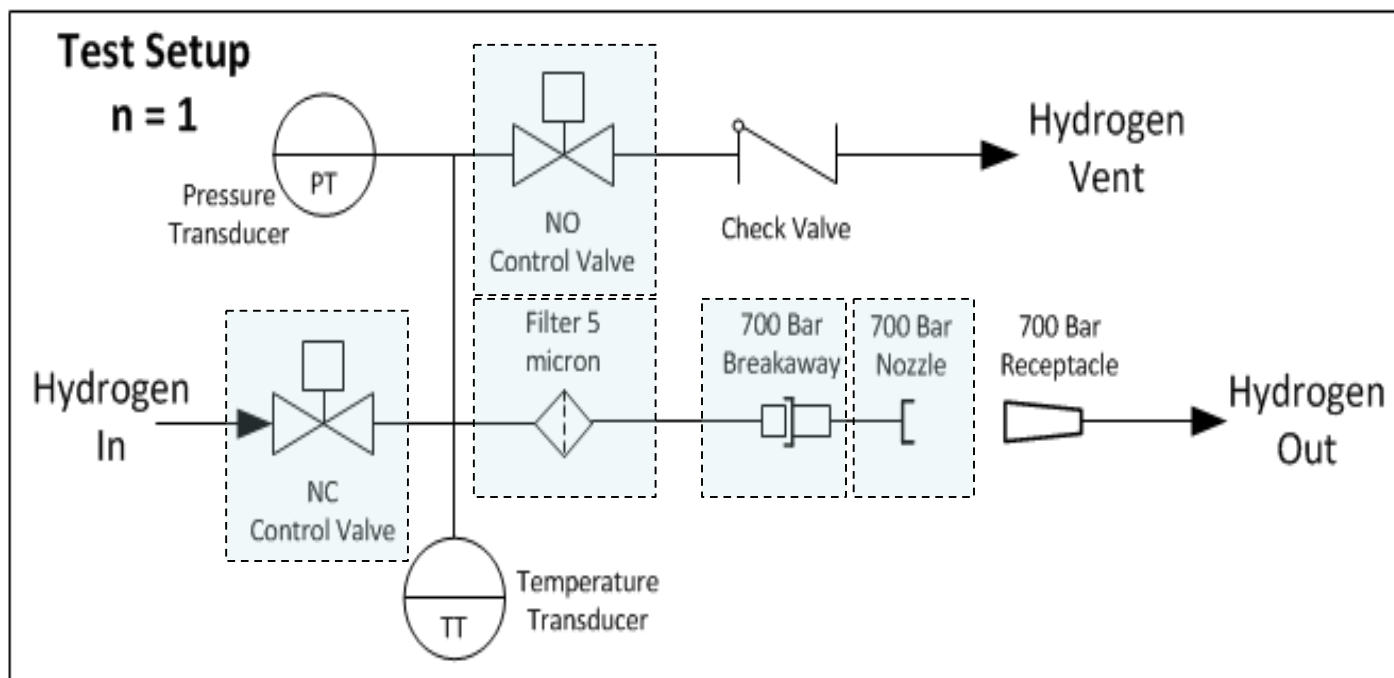

Approach: System

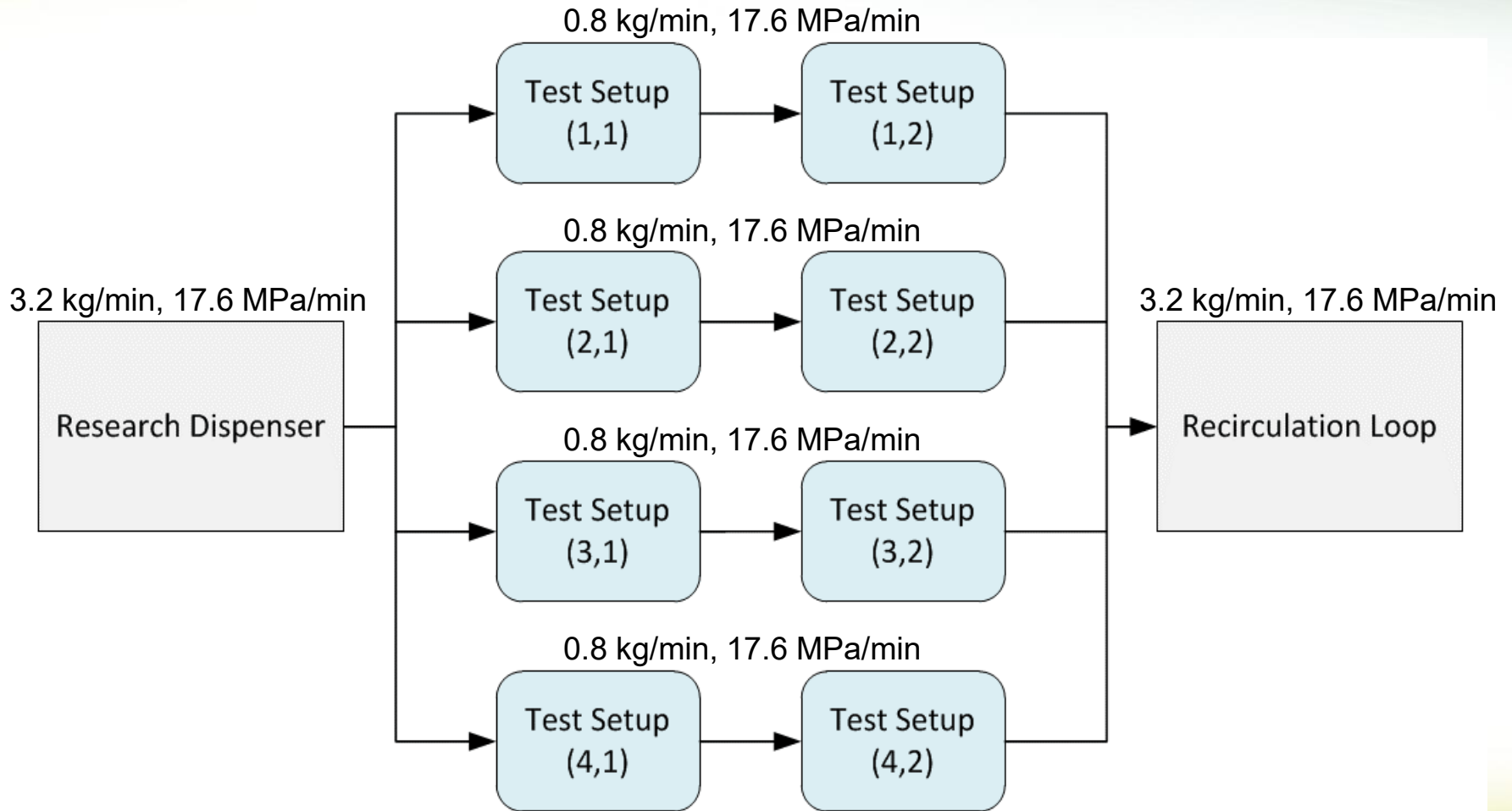

How is a continuous hydrogen flow at a specific ramp rate achieved?

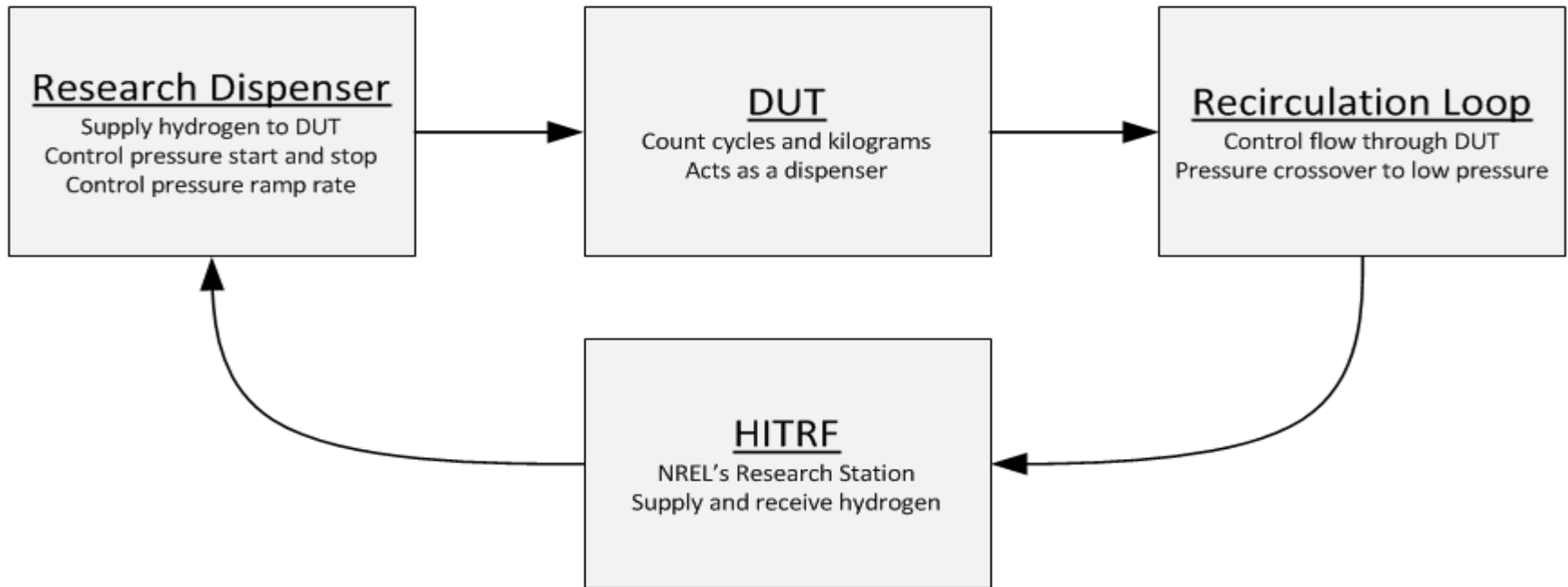

Approach: Flow Diagram



Tankless Vehicle Simulator

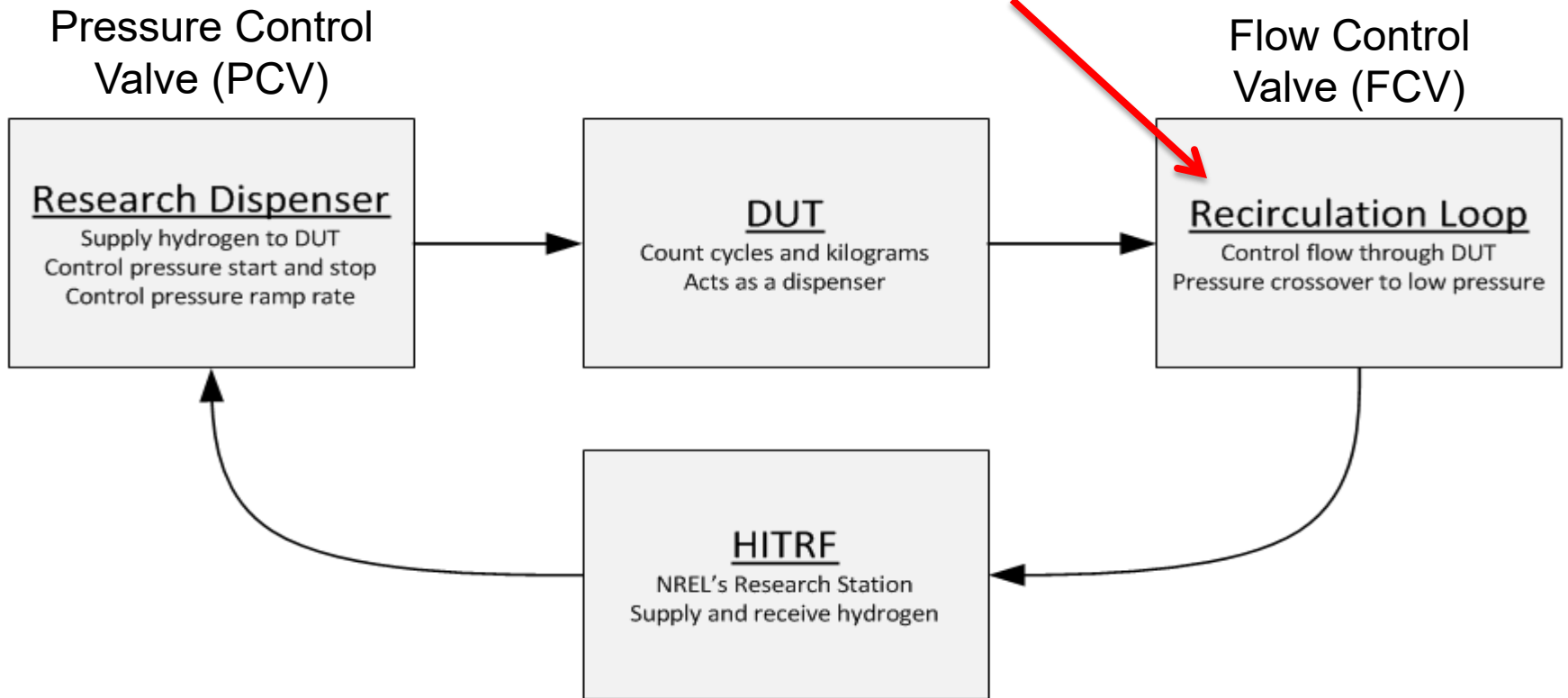

Approach: Leak Detection



- The system looks for leaks with two different methods: mass calculation and hydrogen sensors

Mass and Pressure Tracking

- Mass is calculated using the pressure, temperature, and volume of each section – system looks for $\pm 5\%$ change in the mass

Sensor Tracking

- Dr. Bill Buttner is implementing his Hydrogen Wide Area Monitoring (HyWAM) system to determine optimal sensor placement, response time, and warning/fault set points

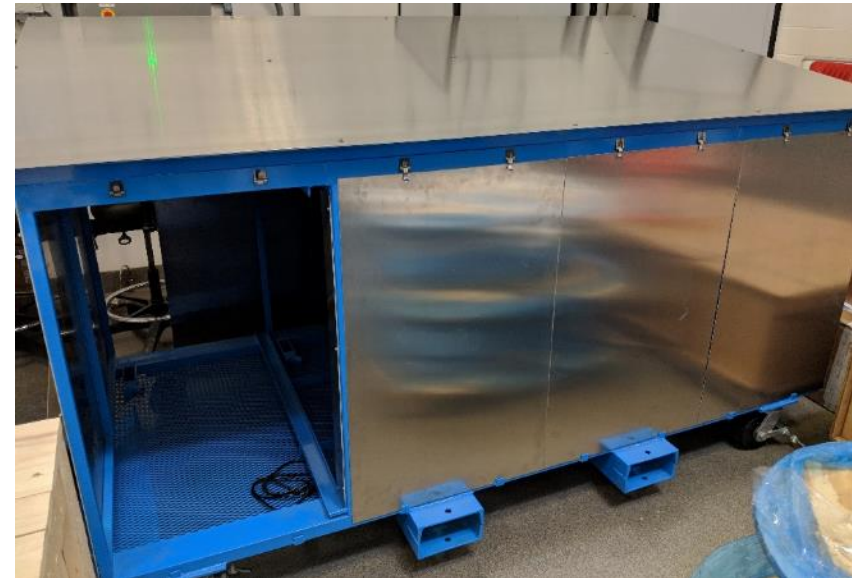

SNL – Polymer characterization on Highly Accelerated Life Testing (HALT) tested components to establish material requirements

- Support of NREL's HALT testing of components with information regarding capabilities and requirements for materials level testing of unexposed and failed components
- Temperatures of test: -40°C, -20°C and 0°C
- First efforts will involve the establishment of baseline properties on polymers retrieved from components not exposed to H₂ - **Complete**
- Baseline properties will be compared to polymeric materials from failed and passed components from the HALT test

Accomplishment: Evaluated, Purchased, and Received DUTs



- Evaluated 15 component manufacturers for initial round of testing
 - Product cost and technical ability (performance, current field usage, ability to manufacture multiple components quickly) were the main drivers for decisions
- Two manufacturers per component category were picked
- For just the DUTs the hardware cost came out to \$460k
- Cost savings through bulk order or in-kind contribution: ~\$150k

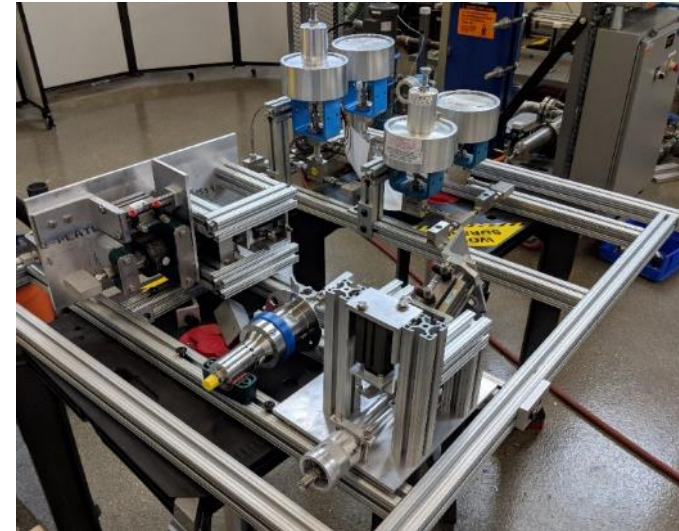

<i>Component</i>	Manufacturer
Nozzles	Weh, Walther
Breakaways	Weh, Walther
Normally Closed Valve	Parker, HiP
Normally Open Valve	Parker, HiP
Filter	Autoclave, Maximator

Accomplishment: Finalized System Design and Built Platforms



- Research dispenser and recirculation loop
 - Conducted multiple design reviews to enable research dispenser and recirculation integration
 - Established controls scheme
 - Built prototype and began testing
- DUTs
 - Designed standard platform for DUTs
 - Built six platforms including actuation systems for nozzle/receptacle engagement
- Integration
 - Established communication protocol between research device and NREL hydrogen station

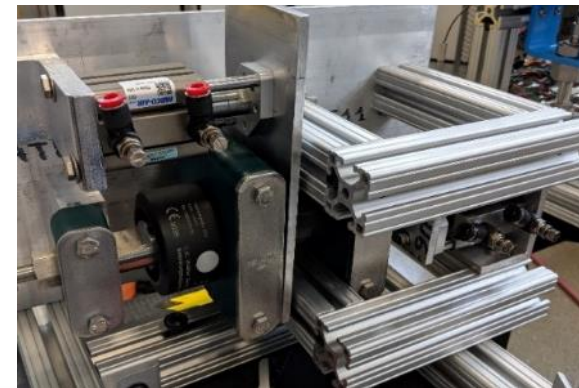
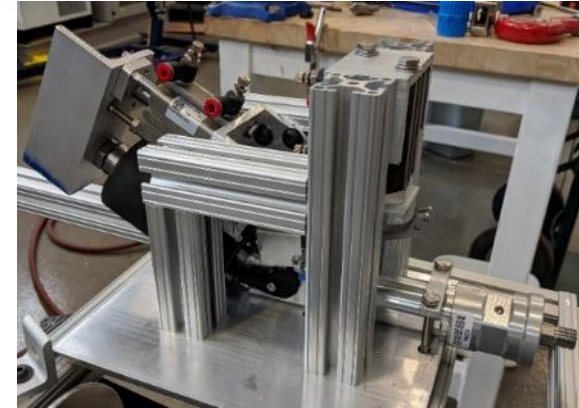

Accomplishment: Prepared the Site



- Process hazard analysis: 6 sessions x 4 hours each x 6 NREL engineers
- Safe work permit (x3): shakedown (commissioning), project (attended), unattended operation
- Readiness verification: included entire project team + NREL operation and safety + DOE safety team
- System scheduling: established plan with hydrogen station operations group on when and how often testing can take place
- Statistical analysis: created MATLAB processing system
- Established data management system in FileMaker Pro
- Built multiple timeline scenarios



Accomplishment: System Commissioning



Recirculation

Research Dispenser



Validated the programming of the research dispenser and interaction between research dispenser and recirculation loop

System Commissioning Test Fill

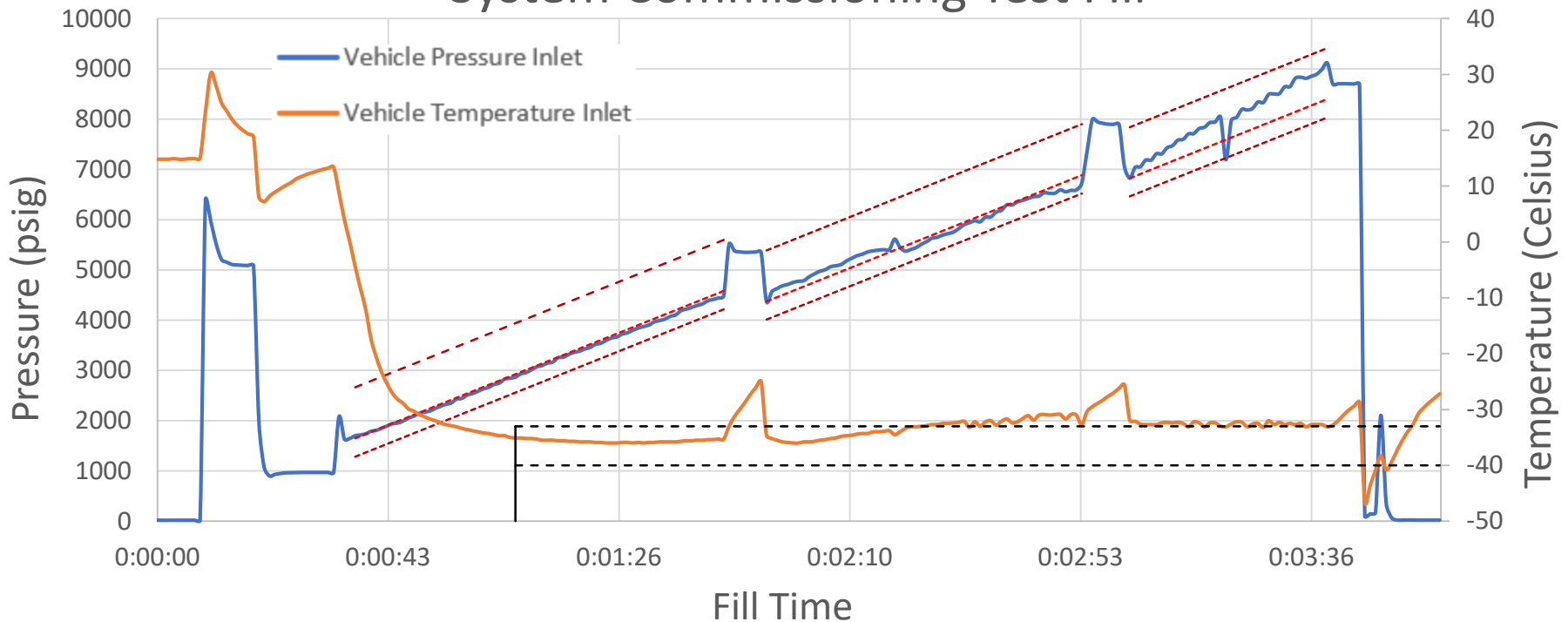

Response to Reviewers Comments



The project does not appear to be following standard reliability test protocol.

Response: Correct. We are testing components in a field-like environment. We do not intend to test components under standard reliability protocol that other entities like ASME may develop. A standard reliability test or certification would be best to be carried out by a NRTL or similar test laboratory. The intention is to as closely as possible mimic field failures.

It looks like very little progress has been made to date on any of the tasks.

Response: What you are getting at AMR only scratches the surface of what it takes to get projects in and out of the laboratory. Hardware testing of this scale takes time to prepare and execute. We have to make sure that we have considered every option before making the decision on large purchases for hardware testing.



Component Manufacturers

- Manufacturers are interested in the project and want detailed results provided back to them
- Walther and Weh are actively monitoring the project status and providing feedback to the test plan and early results
 - NREL visited Walther and Weh: December 2016
 - Weh to visit NREL: June 2018
- Component manufacturers outside of initial test scope are also interested in testing
 - Staubli visited NREL: November 2017

Funding Uncertainty

- Funding cycles and available budget vary by year. There was some uncertainty in this year's budget, which led to a project rescope and slowed purchasing decisions.

Detailed Data Sharing

- Reliability performance results will be distributed publicly through this project. Findings from the material testing could be useful as a whole to the hydrogen community; however, NREL and SNL will need to work with the component manufacturers to ensure we are not revealing proprietary design information.

Future Work: Execute, execute, execute



- Execute project test plan for -40°C, -20°C, and 0°C testing
- Send failed samples to SNL for analysis
- Provide detailed failure and material analysis to the component manufacturers
- Report reliability findings out to public

Any proposed future work is subject to change based on funding levels

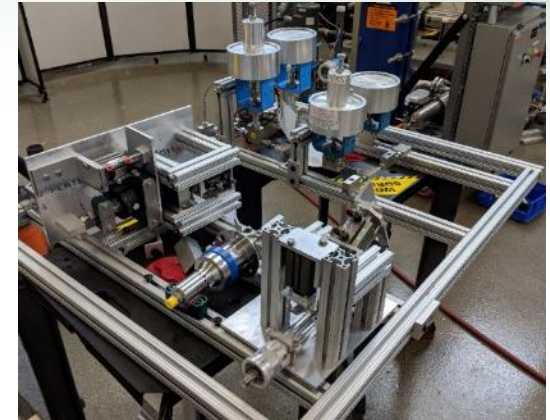

- Relevance
 - Dispensers are top cause of downtime in the field
 - Component testing is beneficial to better understand the effects of temperature on these components
- Approach
 - Perform accelerated life testing of components to failure under different temperature conditions
 - Define field-like test requirements
 - Design system capable of testing multiple dispensers at once and be capable of testing failures
- Accomplishments
 - Evaluated, purchased, and received devices to test ~\$460k in hardware
 - Completed design and build of research dispenser, recirculation loop, and devices under test platforms
 - Commissioned research dispenser and recirculation loop
- Future Work
 - Execute on reliability testing at different temperatures
 - Perform material testing
 - Provide feedback to industry and the public

Michael Peters – NREL – Michael.Peters@NREL.gov

Nalini Menon – SNL – ncmenon@sandia.gov

THANK YOU

TECHNICAL BACKUP SLIDES

Variable Factors

Controlled

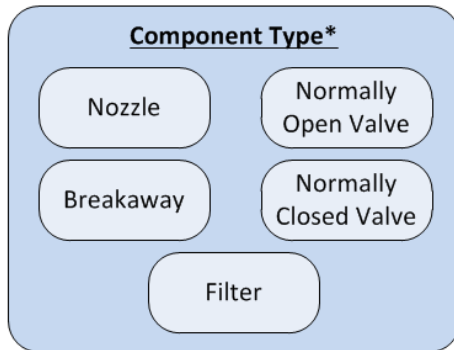
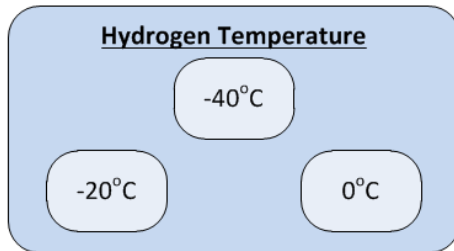

Uncontrolled

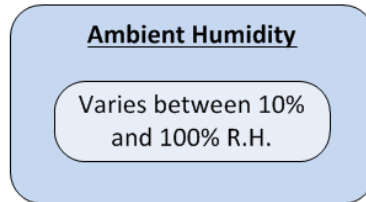
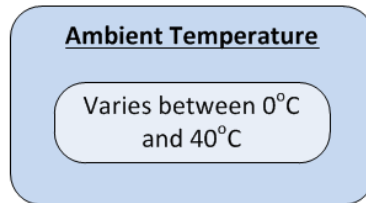

Fixed Factors

Controlled

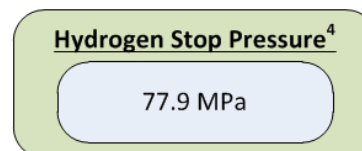
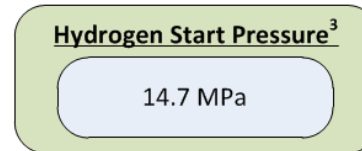
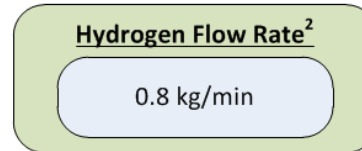

Response Variables

Unpredictable

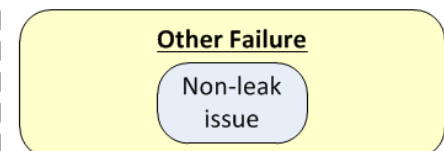
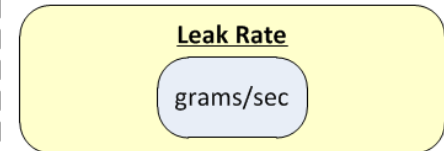
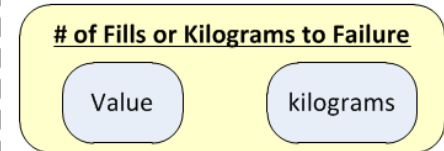
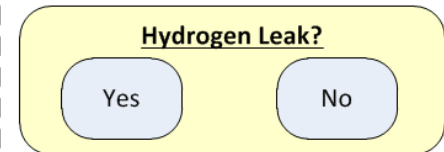

*Components can be broken into subgroups by manufacturer but individual company performance will not be reported. Each component type has two manufacturers.

Sources: Fill Time (1) - <https://www.nrel.gov/hydrogen/assets/images/cdp-retail-infr-03.jpg> Hydrogen Flow Rate (2) - <https://www.nrel.gov/hydrogen/assets/images/cdp-retail-infr-02.jpg> Hydrogen Start Pressure (3) - https://www.nrel.gov/hydrogen/assets/images/cdp_fcqv_15.jpg Hydrogen Stop Pressure (4) - <https://www.nrel.gov/hydrogen/assets/images/cdp-retail-infr-09.jpg>

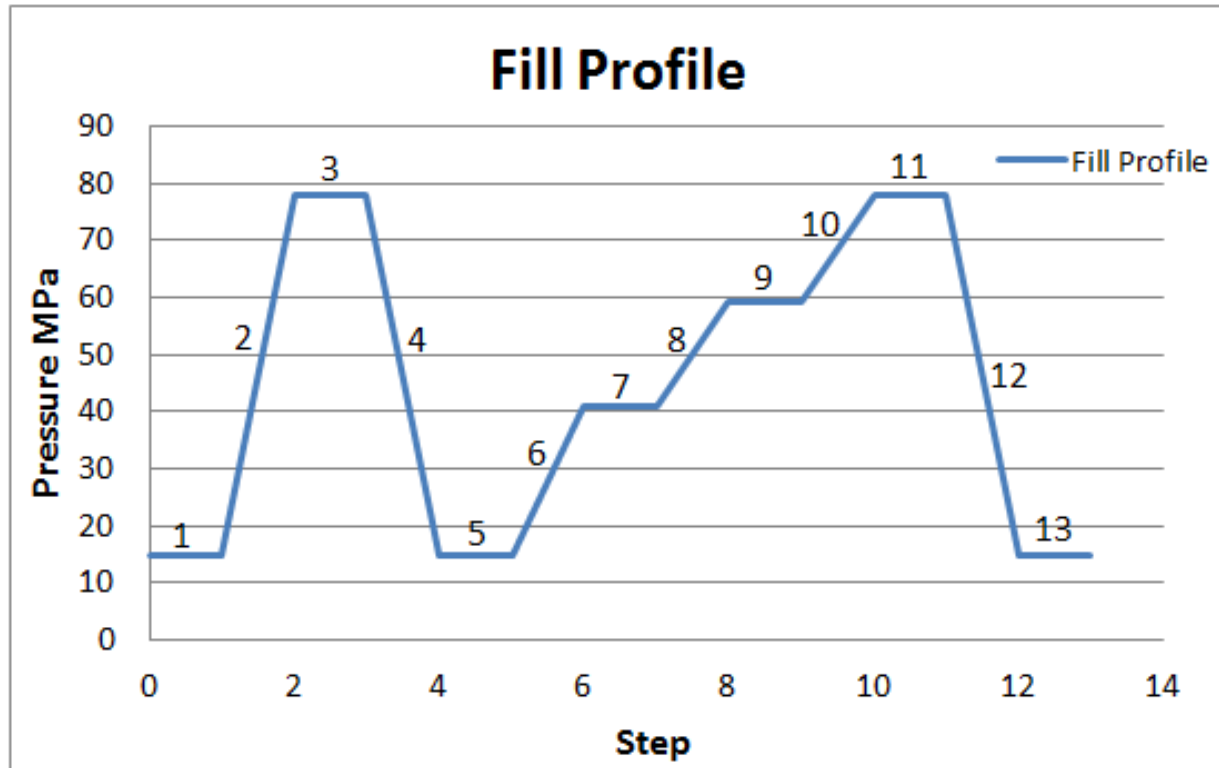

Fill Profile – Step key



Step 0 – Standby

- All valves closed
- PCV closed
- Nozzles disengaged
- FCV 100% open

Step 1 – Initialize

- 5 second hold
- Open research dispenser NC AOV
- Engage all 8 DUT nozzles

Step 2 – Pressure pulse

- Pulse open PCV to full fill pressure
- Open DUT block valves
- Allow pressure in DUT to equalize

Step 3 – First leak check

- Mass/pressure leak check at each DUT
- Verify no leaks in the system
- Close DUT block valves
- Close PCV

Step 4 – Pressure pulse vent

- Open DUT block valves
- First recirculation block valve open, recirculation bleed valve open

Step 5 – Equalize with vehicle

- Equalize to fill start pressure (simulating vehicle) – PCV set to 14.7 MPa
- Hold for 10 seconds
- FCV to start pressure and flow rate set point

Step 6 – Pressure ramp

- Ramp PCV to 17.6 MPa/min
- Reach desired temperature within 30 seconds of the fill start
- Open both recirculation block valves, close bleed valve
- Control flow rate through FCV to 3.2 kg/min

Step 7–11 – Complete fill

- 7, 9, 11 same as step 3
- 8, 10 same as step 6

Step 12 – Vent system

- Close all the DUT block valves
- Vent through DUT bleed valves, stress the bleed valves like a dispenser

Step 13 – Reset system

- All valves to standby mode
- User sets delay between next run
- Disengage 8 DUT nozzles

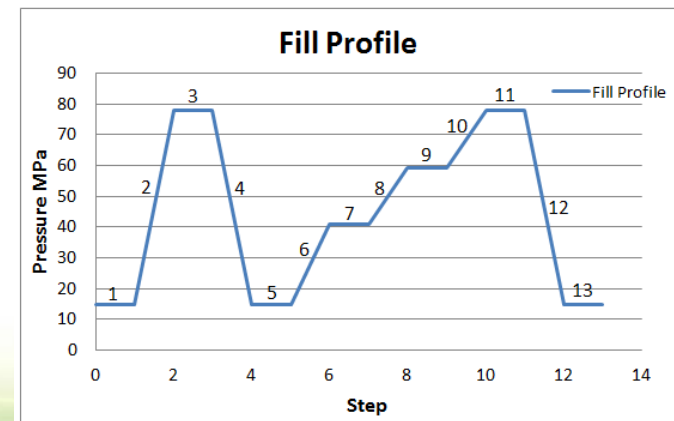

Data and Inventory Management



- Inventory system capable of cataloging each component part number, temperature level, location on device, and cycles
- Barcode scanner and part number labeling
- Linked to data collection and analysis system
- Inventory system made in FileMaker Pro

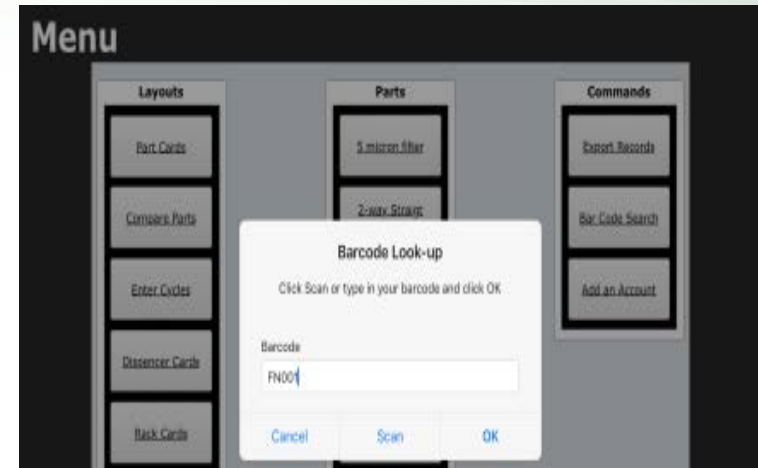

- MATLAB connection to FileMaker Pro and DUT data collection
 - Active components (FileMaker) + kilograms through and other metrics (DUT data) → analyzed in MATLAB
- Weibull analysis to determine the characteristic life (η) and shape factor (β) of each component
- The Crow-AMSAA reliability growth test will be used to illustrate changes in reliability based on the different factors

