

Dissolution

INTRODUCTION ▶▶▶

Copley Philosophy

Robust	✓	Reliable	✓
Easy to use	✓	Compliant	✓

Tablets or capsules taken orally remain one of the most effective means of treatment available.

One of the problems facing the pharmaceutical industry is to optimise the amount of drug available to the body i.e. its **bioavailability**. Inadequacies in bioavailability can mean at best that the treatment is ineffective, and at worst potentially dangerous (toxic overdose).

Drug release in the human body can be measured ***in vivo*** by measuring the plasma or urine concentrations in the subject concerned. However, there are certain obvious impracticalities involved in employing such techniques on a routine basis.

These difficulties have led to the introduction of official ***in vitro*** tests, which are now rigorously and comprehensively defined in the respective Pharmacopoeias.

The principal function of the dissolution test may be summarised as follows:

- Optimisation of therapeutic effectiveness during development and stability assessment
- Routine assessment of production quality to ensure uniformity between production lots

- Prediction of *in vivo* availability i.e. bioavailability (where applicable)
- Assessment of **bioequivalence** (production of the same biological availability from discrete batches of products from one or different manufacturers) and its application in Scale-Up and Post Approval Changes (SUPAC)

Whether or not its numbers have been correlated *in vivo*, the standard dissolution test is a simple and inexpensive indicator of a product's physical consistency.

Initially developed for immediate release (IR) and then to extended / delayed or modified release (MR) oral dosage forms, the role of the "dissolution test" has now been expanded to the "drug release" of various other forms such as semi-solids, suppositories, topical and transdermal systems.

The term **dissolution test** is usually used to describe the testing of those forms, such as immediate release oral tablets or capsules intended to dissolve rapidly, in the test medium.

For non-oral dosage forms such as semi-solids, suppositories, topical and transdermal systems, the term **drug release** is normally employed.



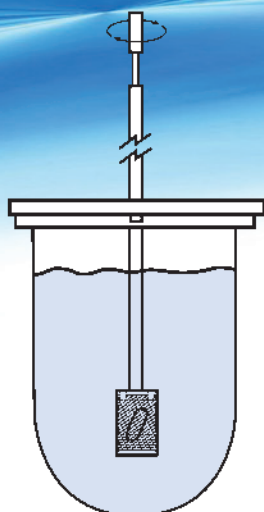

Apparatus 1 - Basket

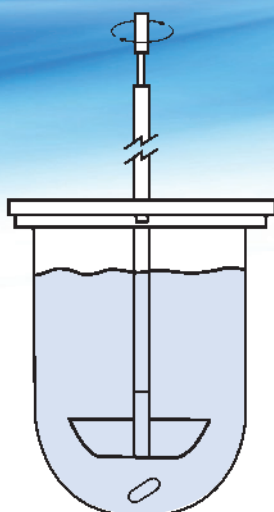

Apparatus 2 - Paddle

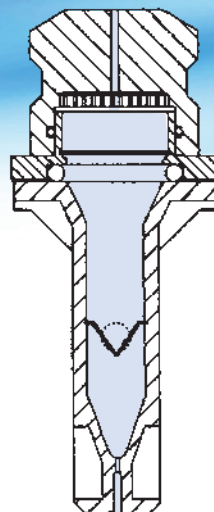

Apparatus 4 - Flow Through Cell

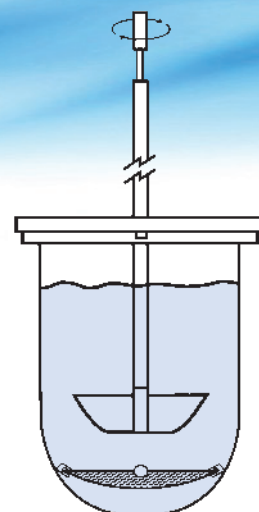

Apparatus 5 - Paddle over Disc

THE ROLE OF THE REGULATOR

The **Quality by Design (QbD)** approach adopted by the EMA, FDA and the Japanese MHL in the form of the four quality related guidelines, ICH Q8, Q9, Q10 and Q11 published by the **International Conference on Harmonisation (ICH)** extends the PAT philosophy to all parts of the product cycle from product development, transfer to manufacturing, manufacturing, and finally product end.

Collectively, these provide the guidelines for a new **Pharmaceutical Quality System (PQS)** described in ICH Q10.

Work is currently under way on ICH Q12, which will link with ICH Q8-Q11 guidelines to provide a framework to facilitate the management of the entire "Pharmaceutical Product Lifecycle".

The decision to include development in the PQS by way of the QbD approach is described in more detail in **ICH Q8 (R2) Part II Pharmaceutical Development - Annex**.

This annex gives examples of many of the essential concepts employed in QbD, including **Critical Quality Attributes (CQAs)**, Design Space and Control Strategy, and its implementation through **Process Analytical Technology (PAT)** tools.

Dissolution or, perhaps more correctly, **Drug Release** is an essential Critical Quality Attribute (CQA) in the development, manufacture and QC of virtually all medicines available today.

From a regulatory perspective, the **Food and Drug Administration (FDA)** has published five main Guidances for Industry relating to dissolution:

- SUPAC-IR Immediate-Release Solid Oral Dosage Forms: Scale-Up and Post-Approval Changes: Chemistry, Manufacturing and Controls, *In Vitro* Dissolution Testing, and *In Vivo* Bioequivalence Documentation, January 1995
- Dissolution Testing of Immediate Release Solid Oral Dosage Forms, January 1997
- SUPAC-MR Modified-Release Solid Oral Dosage Forms: Scale-Up and Post-Approval Changes: Chemistry, Manufacturing and Controls, *In Vitro* Dissolution Testing, and *In Vivo* Bioequivalence Documentation, June 1997
- Extended Release Oral Dosage Forms: Development, Evaluation and Application of *In Vitro/In Vivo* Correlations, September 1997

- The use of Mechanical Calibration of Dissolution Apparatus 1 and 2 - Good Manufacturing Practice (CGMP), January 2010
- Q4B Evaluation & Recommendation of Pharmacopeial Texts for Use in the ICH Regions Annex 7 (R2) Dissolution Test General Chapter, June 2011

A similar function to the FDA is provided in the European Union (EU) by the **European Medicines Agency (EMA)** in the form of the **Committee for Medicinal Products for Human Use (CHMP)**, with guidances based principally on ICH recommendations.

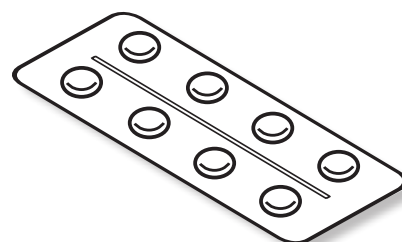

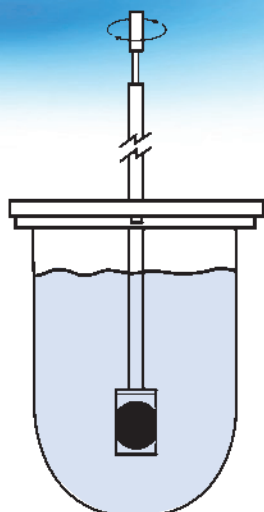

Apparatus 6 - Cylinder

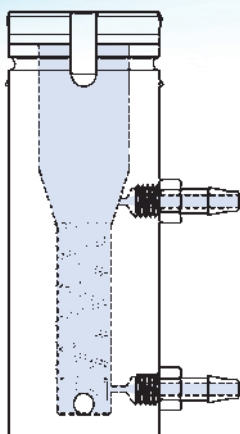

Vertical Diffusion Cell (Franz Cell)

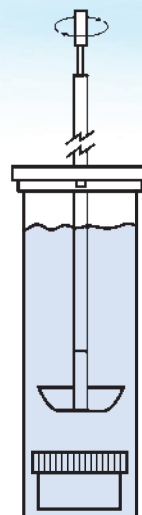

Special Immersion Cell

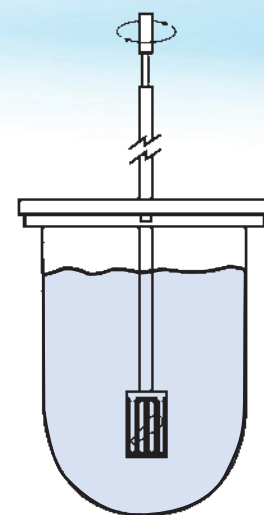

Special Suppository Basket

PHARMACOPOEIAL REQUIREMENTS

The main role of the Pharmacopoeias is to lay down suitable quality standards, requirements and tests to ensure the safety and efficacy of the various drugs and excipients used in modern medicine.

As with the regulatory bodies, the main Pharmacopoeias lie with the European, Japanese and US bodies.

The value of the dissolution test, or perhaps more correctly drug release, as a tool in pharmaceutical development and quality control is reflected in the number of chapters bearing direct or indirect reference to it in the compendia.

In the **United States Pharmacopeia (USP)** for example, there are no less than nine chapters referencing dissolution:

- <711> Dissolution
- <724> Drug Release
- <1058> Analytical Instrument Qualification
- <1087> Intrinsic Dissolution
- <1088> *In Vitro* and *In Vivo* Evaluation of Dosage Forms
- <1090> Assessment of Drug Product Performance
- <1092> Dissolution Procedure: Development & Validation
- <1094> Capsules - Dissolution
- <2040> Dissolution of Dietary Supplements

Note: Chapter numbers less than <1000> are mandatory whilst those above <1000> are for guidance only.

A similar situation exists as far as test methods are concerned with seven methods currently listed:

- Apparatus 1 - Basket <711>
- Apparatus 2 - Paddle <711>
- Apparatus 3 - Reciprocating Cylinder <711>
- Apparatus 4 - Flow-Through Cell <711>
- Apparatus 5 - Paddle over Disk <724>
- Apparatus 6 - Cylinder <724>
- Apparatus 7 - Reciprocating Holder <724>

Attention should also be drawn to the **Vertical Diffusion Cell (Franz Cell)** and **Immersion Cell** now included in the US Pharmacopeia and used for testing the *in vitro* release rate of semi-solid dosage forms such as creams, gels and ointments (Semisolid Drug Products - Performance Tests USP Chapter <1724>).

The **European Pharmacopoeia (Ph. Eur.)** categorises its Dissolution Chapters in a similar manner, thus:

- 2.9.3 Dissolution test for solid dosage forms
- 2.9.4 Dissolution test for transdermal patches

- 2.9.25 Dissolution test for medicated chewing gum
- 2.9.29 Intrinsic Dissolution
- 2.9.42 Dissolution test for lipophilic solid dose forms (suppositories)
- 2.9.43 Apparent Dissolution

At first sight, this proliferation of equipment and procedures can appear confusing.

Suffice it to say, however, that the drug release of all but the most specialised of dosage forms can be tested with a combination of the following three apparatus:

1. **Apparatus 1 - Basket Method**
2. **Apparatus 2 - Paddle Method (plus appropriate accessories)**
3. **Vertical Diffusion Cell**

This includes tablets, gelatin capsules, oral suspensions, orally disintegrating and chewable tablets, transdermal patches, semi-solids such as creams, gels and ointments and suppositories (see Table on Page 20).

Dissolution/Drug Release Apparatuses available from Copley and their Applications

Apparatus 1 – Basket

The dosage form is contained within a 40 mesh basket attached to the stirring shaft, lowered into the medium and rotated typically at either 50 or 100 rpm (≥ 100 rpm may be more suitable for modified release dosage forms).

- Beads (use a finer mesh basket where appropriate)
- Capsules (preferred over Apparatus 2)
- Orally disintegrating (orodispersibles)
- Tablets

Apparatus 2 – Paddle

The dosage form is dropped directly into the medium, which is stirred by means of a paddle attached to the stirring shaft rotated typically at 50 or 75 rpm (≥ 100 rpm may be suitable for modified release forms).

- Capsules
- Hydrogels
- Liquid Filled Capsules
- Orally disintegrating (orodispersibles)
- Powders
- Suspensions
- Tablets (preferred over Apparatus 1)
- * Soft Shell Capsules (Rupture Test 500 mL, 50 rpm)

Apparatus 5 – Paddle over Disk

A variation on Apparatus 2. The dosage form is applied to a stainless steel disk or watch glass, which is then placed in the bottom of the vessel prior to being stirred in the conventional manner. Test at 32 degrees C and pH 5-6 to reflect skin conditions.

- Transdermal Patches (Drug Release Studies)
- Products involving delivery through the skin

Apparatus 6 – Cylinder

A variation on Apparatus 2. The dosage form is applied to a rotating cylinder attached to the stirring shaft in the conventional manner.

- Transdermal Patches (Drug Release Studies)

Apparatus Chapter <1724> - Vertical Diffusion Cell (Franz Cell)

For drug release studies on topical semi-solids. The VDC is a small volume heated/stirred cell with a donor chamber containing the dosage form to be tested, a synthetic membrane through which the drug permeates and a receptor chamber from which samples may be analysed for drug release. Test at 32 degrees C to reflect skin conditions.

- Creams
- Gels
- Implants
- Lotions
- Ointments
- Transdermal Patches (Permeation Studies)

Accessories for Special Applications

Suppository Basket

The dosage form is contained in a special polyurethane basket similar to that employed in Apparatus 1 but having 12 linear slots 2.5 mm wide in place of the conventional 40 mesh and used typically at 50 rpm using a phosphate buffer solution pH 7.4 at 37 degrees C.

- Suppositories (hydrophilic)

Mini-Paddle Systems

A variation on Apparatus 2. Two systems, (a) 100 ml and (b) 200 mL, are available based on scaled down versions of the standard apparatus.

- Low dosage strength forms

Immersion Cell

A special form of Apparatus 2 using a mini paddle and 200 mL flat bottomed vessel designed for use with topical semi-solids. The dosage form is constrained within a cell placed at the bottom of the vessel. The cell serves to ensure that the surface area of the dosage form exposed to the dissolution media always remains constant.

- Creams
- Gels
- Implants
- Lotions
- Ointments
- Microparticulates

Apparatus for testing the drug release of orally inhaled and nasal drug products

A variation on Apparatus 5. The inhaled dose is collected on a special dissolution cup by means of a cascade impactor whereupon, it is then transferred to a stainless steel disk or watch glass placed in the bottom of the vessel containing 300 mL of dissolution media stirred at 75 rpm.

- Orally inhaled and nasal drug products

Intrinsic Dissolution (Rotating Disc)

A special kit designed to form a compact, the holder for which is then attached to the stirring shaft in the normal manner. The cell serves to ensure that the surface area of the dosage form exposed to the dissolution medium always remains constant.

- Pure drug compacts

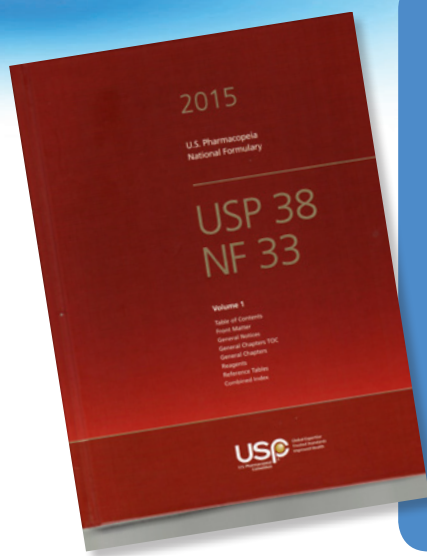

USP Studies into the sources of mechanical variation

A Design of Experiment (DOE) study reported by USP in 2007 (Joseph Eaton *et al.* Perturbation Study of Dissolution Apparatus Variables - A Design of Experiment Approach. *Dissolution Technologies*. February 2007, Volume 14, Issue 1) found three variables that were statistically significant as far as mean percent dissolved was concerned: level of deaeration, vessel type and rotation speed. When standard deviation results were taken into account, paddle height was also significant.

Vessel geometry constantly features as a source of concern. In the same issue as the article above, USP reported significant differences in the geometric dimensions and surface irregularities of eleven sets of six dissolution vessels selected from 10 commercial sources (Liddell *et al.* Evaluation of Glass Dissolution Vessel Dimensions and Irregularities. *Dissolution Technologies*. February 2007, Volume 14, Issue 1).

CURRENT ISSUES

It is widely acknowledged that the rate at which, for example, a tablet or capsule dissolves is critical to its therapeutic effectiveness, that is to say, it is a **Critical Quality Attribute (CGA)** in its *in vitro* characterisation.

Unfortunately, as with any *in vitro* test, there are outside variables other than those caused by the dosage form itself which may affect results.

A number of studies have been carried out by both the FDA and USP (see box above) to identify the different sources of mechanical variation within the USP Dissolution Apparatus that lead to variability in results.

This has resulted in calls from both regulators and industry alike for a tightening of the original mechanical specifications relating to Dissolution Testers laid down in the Pharmacopoeias to ensure that those tolerances that are critical to the process are maintained within known limits and policed by a process known as **Enhanced Mechanical Calibration (EMC)**.

Such suggested "enhancements" would not have been possible in the 1970s when the dissolution tester was first introduced. Fortunately, improvements in the precision of machine tools and metrology techniques used to manufacture and

qualify the modern day dissolution tester means that, today, enhanced mechanical calibration is not only a possibility but a reality.

MINIMISING VARIABILITY

Based on our own research, we quickly recognised that the critical elements of a dissolution tester, and therefore those most likely to affect the accuracy of results, were the ones making up the actual test station, namely the dissolution vessel itself and the associated stirring element.

It followed that if we could control the dimensions of these critical elements and their spatial relationship and then ensure that the speed of the stirring element and the composition of the dissolution media (see Page 41) are maintained within equally tight limits, then any instrument's contribution to test method variability would be minimised.

The dissolution community has long recognised that one of the major problems with respect to variability of results relates to **vessel dimensions and irregularities**. We determined from the outset that if we were able to resolve the problems arising from the vessel, then the problems emanating from the other element of the test station - the stirring element - could be easily resolved.

Traditionally, dissolution vessels have been made individually using manual glass blowing techniques from extruded glass tubing having a nominal tolerance of ± 2 mm. Unfortunately, even by using specially selected tubing, it was not possible to obtain the tolerances we had set ourselves (twice as tight as those specified by the FDA) using this technique.

The solution, the **EMC Dissolution Vessel**, was to vacuum form the vessel as opposed to extruding it. In this method, the glass blank employed to produce the dissolution vessel is first heated to 2000 degrees C before being vacuum formed by shrinking it on to a precision ground mandrel. This technique not only guarantees the required dimensional tolerances but also a perfectly formed hemispherical bottom free of imperfections.

It is the EMC Dissolution Vessel that forms the basis of the Copley Dissolution Tester Series DIS-EMC described on Page 30.



CURRENT ISSUES

CALIBRATION

The subject of calibration continues to stimulate considerable discussion amongst those organisations involved in dissolution testing.

Currently, the method of calibration adopted by USP in Chapter <711> has been to calibrate dissolution testers on a six-monthly basis using a combination of mechanical checks and performance verification reference tablets (formerly known as dissolution calibrators) to establish apparatus suitability.

Performance Verification Testing (PVT) is time consuming and concerns have been raised in some quarters about the wide acceptance ranges and variability of the results generated by the reference tablets used.

Consequently, there has been a move towards **Enhanced Mechanical Calibration (EMC)** as an alternative, or at least, a precursor to chemical means.

This alternative approach was endorsed by the Food and Drug Administration (FDA) in its current guidance on the subject, **"The use of Mechanical Calibration of Dissolution Apparatus 1 and 2 - Current Good Manufacturing Practice (CGMP)"**, published in January 2010.

This guidance suggests that "an **EMC** procedure (such as *FDA Document No. DPA-LOP.002 "Mechanical Qualification of Dissolution Apparatus 1 and 2"* or *ASTM E 2503-13 "Standard Practice for Qualification of Basket and Paddle Dissolution Apparatus"*)* can be used as an alternative to the current Apparatus Suitability procedure for Dissolution Apparatus 1 and 2 described in USP General Chapter <711> Dissolution".

USP, on the other hand, maintains that it is not possible to detect such problems as, for example, analyst error, dirty flow cells or insufficient degassing using mechanical calibration alone.

For that reason, USP argues that both mechanical calibration, based on the specifications laid down in USP Chapter <711>, and PVT using USP Prednisone Reference Standard Tablets are necessary to evaluate Apparatuses 1 and 2 and neither procedure is sufficient alone.

In March 2010, USP sought to further clarify its position on the subject by publishing details of a Dissolution Toolkit providing a description of best practices associated with its own Enhanced Mechanical Calibration and PVT of Apparatuses 1 and 2.

Whilst not a standard requiring rigid compliance, the **"Dissolution Toolkit. Procedures for Mechanical Calibration and Performance Verification Test Apparatus 1 and 2. Version 2.0. March 22, 2010"**

represents, according to USP, its continuing effort to provide detailed information describing the procedures that, if used, will assure a properly qualified dissolution test assembly.

It is up to the dissolution laboratory itself to decide which calibration route to follow:

1. The conventional approach specified in USP Chapter <711> using a combination of less rigid mechanical checks supported by PVT testing.
2. The FDA approach based on a more rigid series of mechanical checks alone.
3. A combination of (1) and (2).

The comparison chart opposite illustrates the differences between the current specifications and the suggested Enhanced Mechanical Calibration specifications from both the FDA* and the USP.

* Note: For all intents and purposes, the *ASTM E 2503-13 standard is comparable to that of the FDA (Document No. DPA-LOP.002).*

Comparison between Compendial and Enhanced Mechanical Calibration Specifications

Calibration Parameter	Current Pharmacopoeia	Enhanced USP Specification	Enhanced FDA Specification
Bench Horizontality		≤ 1° from the horizontal	No Specification Given
Vessel Support Horizontality		≤ 0.5° from the horizontal in two orthogonal directions	No Specification Given
Basket Conformance	Must conform to <711> Free of "Gross Defects"	Must conform to <711> Mesh should be perpendicular to basket top and bottom (0.5 mm deviation over 37 mm is approx. equal to 1°). Free of "Gross Defects"	
Paddle Conformance	Must conform to <711> Free of "Gross Defects"	Must conform to <711> Free of "Gross Defects"	Must conform to <711> Free of "Gross Defects"
Vessel Conformance	Must conform to <711> Free of "Gross Defects"	Must conform to <711> Free of "Gross Defects"	Must conform to <711> Free of "Gross Defects"
Shaft Wobble; Basket	Rotate smoothly without significant wobble	Measure a full rotation at the bottom basket rim. Deflection of probe tip should be ≤ 1.0 mm	Gauge on top of the vessel plate, position the shaft such that the gauge is measuring a point 20 mm above the top of the basket. ≤ 1.0 mm total run-out
Shaft Wobble; Paddle	Rotate smoothly without significant wobble	Measure a full rotation. Deflection of probe tip should be ≤ 1.0 mm	Position the shaft such that the gauge is measuring a point 20 mm above the top of the paddle. ≤ 1.0 mm total run-out
Shaft Verticality	N/A	<0.5° from vertical. Check two positions	<0.5° from vertical. Check two orthogonal positions
Wobble; Basket	≤ 1.0 mm total run-out	Measure a full rotation at the bottom basket rim. Deflection of probe tip should be ≤ 1.0 mm	Gauge on top of the vessel plate. ≤ 1.0 mm total run-out at the bottom of the basket
Wobble; Paddle		At a position of 10 mm above paddle blade with the stirring element installed, total deflection of the probe tip during 360° rotation ≤ 1.0 mm	
Shaft Centricity; Basket (Vessel Centring)	≤ 2.0 mm from centreline	Measure the distance from the shaft to the vessel at no more than 20 mm below the vessel flange. Measure at 4 orthogonal locations. The difference between the highest and lowest reading must be ≤ 2.0 mm. Roughly translates to ≤ 1.0 mm away from centreline	≤ 1.0 mm at 2 mm and 60 mm above the basket. Basket at operational height (25 mm above the vessel bottom)
Shaft Centricity; Paddle (Vessel Centring)	≤ 2.0 mm from centreline	Measure the distance from the shaft to the vessel at no more than 20 mm below the vessel flange. Measure at 4 orthogonal locations. The difference between the highest and lowest reading must be ≤ 2.0 mm Roughly translates to ≤ 1.0 mm away from centreline	≤ 1.0 mm from the centreline. At 2 mm and 80 mm above the blade
Vessel Verticality	N/A	± 0.5° from vertical. Check two positions.	≤ 1.0° from vertical. Check two orthogonal positions
Height Check; Basket Depth	25 ± 2.0 mm	25.0 ± 2.0 mm - measure each position	25 ± 2.0 mm
Height Check; Paddle Depth	25 ± 2.0 mm	25.0 ± 2.0 mm - measure each position	25 ± 2.0 mm
Rotational Speed	± 4% from target	± 1 rpm evaluated at 50 and 100 rpm.	± 2 rpm
Temperature	37 ± 0.5°C	37 ± 0.5°C (All vessels to be within 0.4°C of each other when filled with 500 mL of media)	37 ± 0.5°C



Apparatus 1 (Basket) ▲



Apparatus 2 (Paddle) ▲

COPLEY TABLET DISSOLUTION TESTERS

In the majority of cases, the effectiveness of tablets or capsules administered orally relies on the drug dissolving in the fluids of the gastrointestinal tract, prior to absorption through the walls of the gastrointestinal tract into the systemic circulation.

For this reason, the rate at which a tablet or capsule dissolves is critical to its therapeutic efficiency and is a key factor in both the formulation process and final quality control.

The most common apparatus used to measure the dissolution rate of solid dose forms are the **basket** and **paddle**.

Both use the same basic configuration, are simple and robust, and can be used to test a variety of different products.

The basic apparatus consists of a covered cylindrical vessel having a hemispherical bottom and capable of holding approx. 1000 mL of simulated gastric juice.

The vessel is partially immersed in a suitable water bath capable of maintaining the temperature of the vessel contents at 37 degrees C.

In the case of the basket method, the tablet or capsule is constrained in a cylindrical basket constructed of sieve mesh of defined proportions.

The basket is attached to a metal drive shaft by a 3-pronged retention spring and the shaft positioned in such a manner that the bottom of the basket is 25 mm from the bottom of the vessel.

In the case of the paddle method, the basket is replaced by a paddle and the sample to be tested is allowed to sink to the bottom of the vessel.

During the test, a motor is used to rotate the drive shaft at the speed (normally 50, 75 or 100 rpm) specified in the Pharmacopoeias.

Speeds outside the range 50 to 150 rpm are usually inappropriate because of hydrodynamic inconsistencies and problems with turbulence.

A sample of the dissolution medium is taken at predefined time intervals to determine the percentage of dissolved drug present – this is normally determined

using a UV/Vis Spectrophotometer or High Pressure Liquid Chromatography (HPLC).

All Copley Dissolution Testers feature:

- Sturdy, robust construction specifically designed to reduce clutter and maximise visibility and access in the critical sampling area above the water bath
- Simple, easy to use operation ensuring that the number of actions required to perform a test are kept to a minimum
- Full supporting documentation (including full IQ/OQ/MQ/PQ qualification documentation if required)

Dissolution Tester Model DIS 8000 ▲

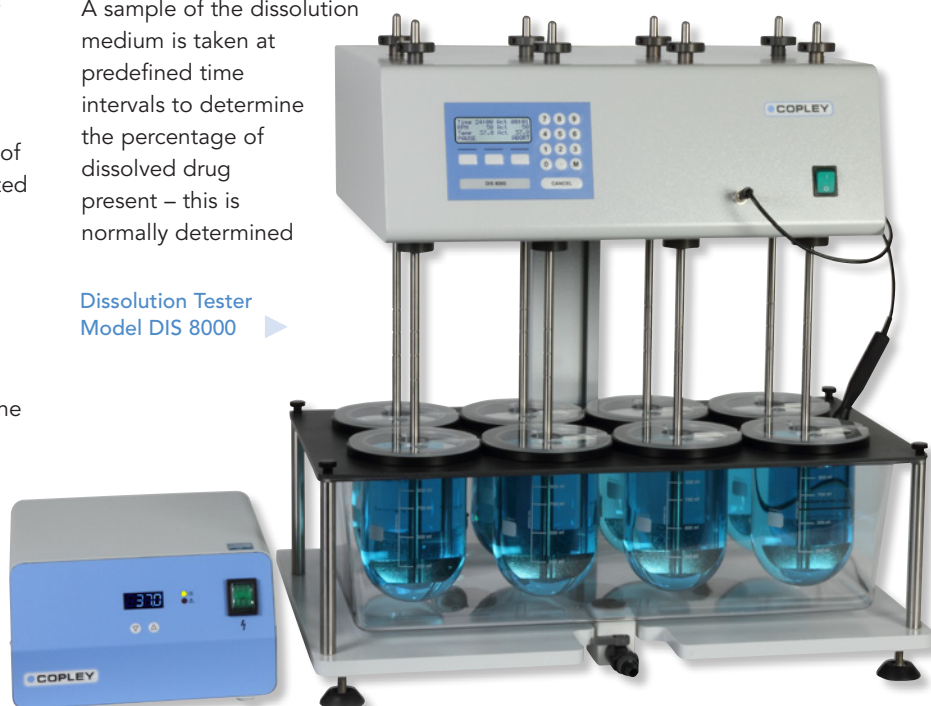

DISSOLUTION TESTER DIS 8000

The Dissolution Tester Series DIS represents the very latest in tablet testing technology. CNC production techniques combined with modern microprocessor design guarantee the highest standards of performance and reliability.

All Copley Scientific dissolution testers meet the latest specifications as laid down in the European, United States and associated Pharmacopoeias.

Efficient and extremely compact, the **Tablet Dissolution Tester DIS 8000** is a rugged (all metal) "no-nonsense" unit having **eight stirred** test vessels and simple, easy to use controls. It is ideal for both R&D and quality control applications.

The design of the unit has been based on those features that you, the user, advised us as being essential to the "ideal" dissolution tester.

PHARMACOPOEIA COMPLIANCE AND QUALIFICATION

The most critical factors in the design of any dissolution tester are (a) that it complies with the respective Pharmacopoeias, (b) that this compliance can be proved or qualified and (c) that both compliance and qualification can be documented.

Copley offer a three tier approach to address these points:

- **Certificate of Compliance to USP/ Ph.Eur.:** Included with each unit. Written statement that the product, by design, complies with the current pharmacopoeial specifications.

Interchangeable Baskets/Paddles ▶



Unfettered access to the critical sampling area above the water bath ▶



- **Laser Numbering and Certification:**

Identification and measurement of critical components to provide documented verification of compliance with current pharmacopoeial specifications. Available as an optional service.

- **IQ/OQ/PQ Qualification**

Documentation: Comprehensive documentation to guide the user through the installation, operating and performance checks of the equipment in its operating environment, using specified test protocols. It provides a comprehensive record of the suitability of the equipment to perform its specified task, to be created and archived.

Please see the ordering information for further details on our verification and qualification services.



DESIGN AND CONSTRUCTION

In common with the rest of the series, the DIS 8000 has been specifically designed to reduce clutter and maximise visibility and access in the critical sampling area above the water bath.

Particular emphasis has been placed on those factors affecting the eccentricity, alignment and centring of the stirring elements in order to reduce the number of parts used and hence keep the machine variables at a minimum.

BASKETS, PADDLES AND ROTATING CYLINDERS

All of the DIS series are equipped with precision-ground drive shafts that will accept any of the baskets, paddles or rotating cylinders described in the respective Pharmacopoeias.

Individual clutches enable each individual basket/paddle to be raised, lowered or engaged independent of the drive head.

This feature is particularly useful in the case of staggered starts, and at the end of the test it allows the baskets/paddles to be pushed upwards to gain maximum accessibility to the vessels.



“Easy-Centre” Vessel Location ▲

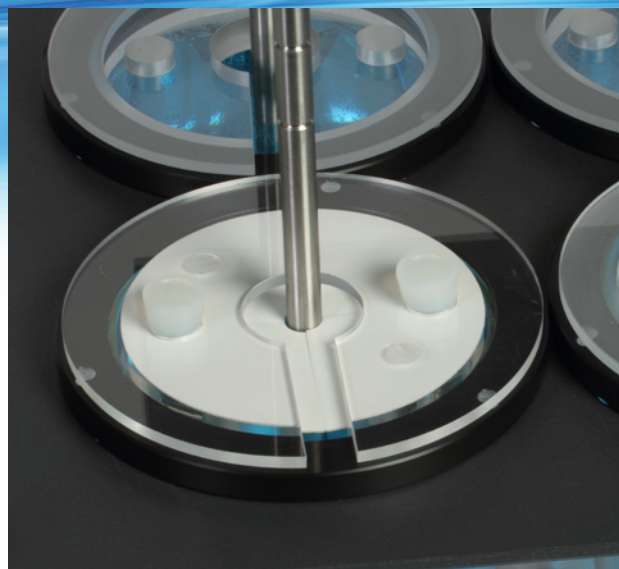

Two-Part Membrane Sealed Lid ▲

DISSOLUTION TESTER DIS 8000

All stirring elements can be laser numbered and certified on request.

The construction of the **baskets and paddles** are such that they are completely **interchangeable**. Simply screw in the appropriate element, with no further height adjustment necessary.

All of the elements can be supplied with a teflon coating for additional protection against aggressive media, if required.

VESSELS, VESSEL CENTRING AND LIDS

All Copley dissolution testers are supplied with USP/Ph.Eur. compliant vessels and feature the unique **Easy-Centre** system to ensure that the vessels are perfectly positioned every time.

The Easy-Centre system is based on a standard 1000 mL borosilicate glass vessel with a rim that has been precision ground and then centred accurately within a two-part acetal ring.

The acetal ring is provided with three bayonet fittings, which locate in recesses provided in the vessel support plate. When turned clockwise these fittings lock the vessel into the correct position relative to the drive shafts.

The fixture is designed such that once secured, the vessels will not become loose or float, even when empty.

All vessels can be numbered and certified on request. UV-resistant amber vessels are also available for those products sensitive to UV.

All vessels are supplied as standard with clear view acrylic lids. Special membrane-sealed two-part lids are available on request, where losses caused by evaporation may be an issue.

CONTROL AND MONITORING OF SPEED AND TEMPERATURE

All of the DIS series of dissolution testers have a speed range of **50-200 rpm**.

The electronic speed control is provided with its own digital closed loop circuitry which guarantees an accuracy of **+/- 2%** by automatically checking and compensating for any drift from the nominal speed.

In the case of the DIS 8000, the temperature of the warming solution is controlled by means of a self-priming **1100 W external digital heater/circulator**, which allows for rapid heating of the test media from ambient to the desired temperature.

The digital heater/circulator has an accuracy of **+/- 0.1 degrees C** thus ensuring a constant and even distribution of heat throughout the bath. It is fitted with an **adjustable over-temperature cut-out** and alarm indicator,

together with a **low-level cut-out** which operates if there is insufficient water available in the bath.

The one piece vacuum formed water bath is constructed in rigid PETG and has been specifically designed to eliminate leaks and to make it easier to clean. A fill line is provided on each bath to indicate the level to which the bath must be filled.

The water bath and the easy to clean teflon-coated 316 stainless steel vessel support plate are supported by four stainless steel pillars and secured by four thumb screws.

The bath and vessel temperatures can be constantly monitored using the **PT100 temperature probe** provided for this purpose. Provision is made for logging the actual speed and temperature at user-defined intervals throughout the test for subsequent printing.

▼ Digital Heater/Circulator



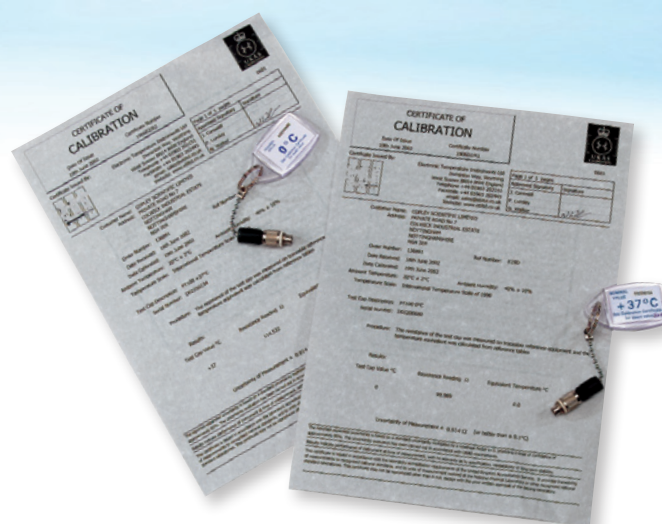
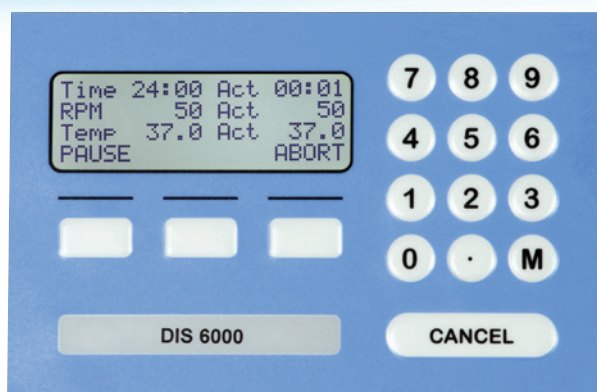

Temperature Calibration Certificate ▲

DISSOLUTION TESTER DIS 8000

OPERATION

The control of all models is provided by a membrane keypad linked to a 4 line, 20 character backlit display, which, together with the electronics, is mounted in the head of the instrument so as to avoid any accidental spillages in the test area.

Many users have criticised the fact that their existing dissolution testers are overly complex with unnecessary software functionality for day-to-day use. For this reason, considerable attention was given in the design to ensuring that the number of actions necessary to perform a test was kept to a minimum.

Once the test sequence has been initiated, all that is necessary to start the test is to input the required rpm and nominal temperature, together with the duration of the test and the report interval (the time interval during the test at which the actual rpm and temperature is logged and subsequently reported), introduce the samples and press START.

During the test the following information is shown on the display:

- Nominal and actual rpm
- Nominal and actual temperature
- Preset test duration and time elapsed

An audible alarm alerts the user that the test is completed.

The dissolution tester is provided with both parallel and USB ports as standard for printout of time, date, bath identification, serial number and date of calibration, together with the speed and temperature at operator selectable time intervals during the test.

CALIBRATION

Routine calibration is an essential part of your operation. Therefore a special calibration menu guides the user through the various functions and provides a printed report at the end of the operation.

One unique feature in this respect is the electronic temperature calibration kit. Ordinarily, temperature calibration can prove to be a time consuming and inaccurate process involving iced water.

Available as an option, the electronic temperature calibration kit comprises two **UKAS certified test keys (0 and 37 degrees C)** which are simply plugged into the PT100 temperature probe socket to perform the calibration.

We offer a wide range of tools for calibrating your dissolution tester.

Please see the appropriate information in the Calibration Tools section on page 39.

AUTOMATION

Manual dissolution testing is extremely time consuming and tedious. For this reason, many users are turning to completely automated systems to fulfill their requirements. As in the DIS 6000 and 8000, in most cases the software involved also controls the dissolution tester.

The DIS 8000 has a bi-directional RS232 interface on the back panel which allows for communication with external devices and incorporation into automated systems.

DIMENSIONS

The DIS 8000 measures:
650 x 450 x 640 mm (w x d x h)
Heater/Circulator measures:
260 x 300 x 150 mm (w x d x h)



Temperature Calibration Kit ▶

DISSOLUTION TESTER DIS 8000

SUMMARY OF KEY FEATURES

Standard

- Rugged (all metal), compact and easy-to-use
- Conforms to all current Ph.Eur. and USP specifications
- User friendly operating procedure via membrane keypad and 4 line LCD screen
- Screw-in baskets/paddles allow method changes in seconds, with no further adjustments necessary
- Individual clutches allow each basket/paddle to be raised, lowered and engaged independent of the drive head
- Uncluttered design allows maximum access to working area
- 316 stainless steel teflon coated vessel support plate
- "Easy-Centre" vessel centring system
- One piece PETG water bath with built-in drain tap - no leaks; easy to remove and clean

- Independent **digital** heater/circulator with over-temperature cut-out and indicator. Easily removed for maintenance
- Full printed test report on completion of the run (user selectable)
- RS232 bi-directional interface and USB/parallel printer port
- Menu guided calibration procedure (with printout)

Options

- Laser numbering, certification and IQ/OQ/PQ documentation
- Teflon coated baskets/paddles for aggressive media
- Amber coated UV-Resistant vessels and lids
- Low evaporation membrane sealed vessel lids
- Electronic temperature calibration kit

Cat. No. Description

1301	Dissolution Tester DIS 8000 (incl. 8 Drive Shafts)
1302A	Set of 8 Baskets (Ph.Eur./USP Method 1)
1304A	Set of 8 Paddles (Ph.Eur./USP Method 2)
1307	Printer (including USB Cable)
1207	Electronic Temperature Calibration Kit
1309	IQ/OQ/PQ Documentation Pack

Extra for Laser Numbering and Certification

See Page 33

▼ DIS 8000 with DissoMate Media Preparation Station

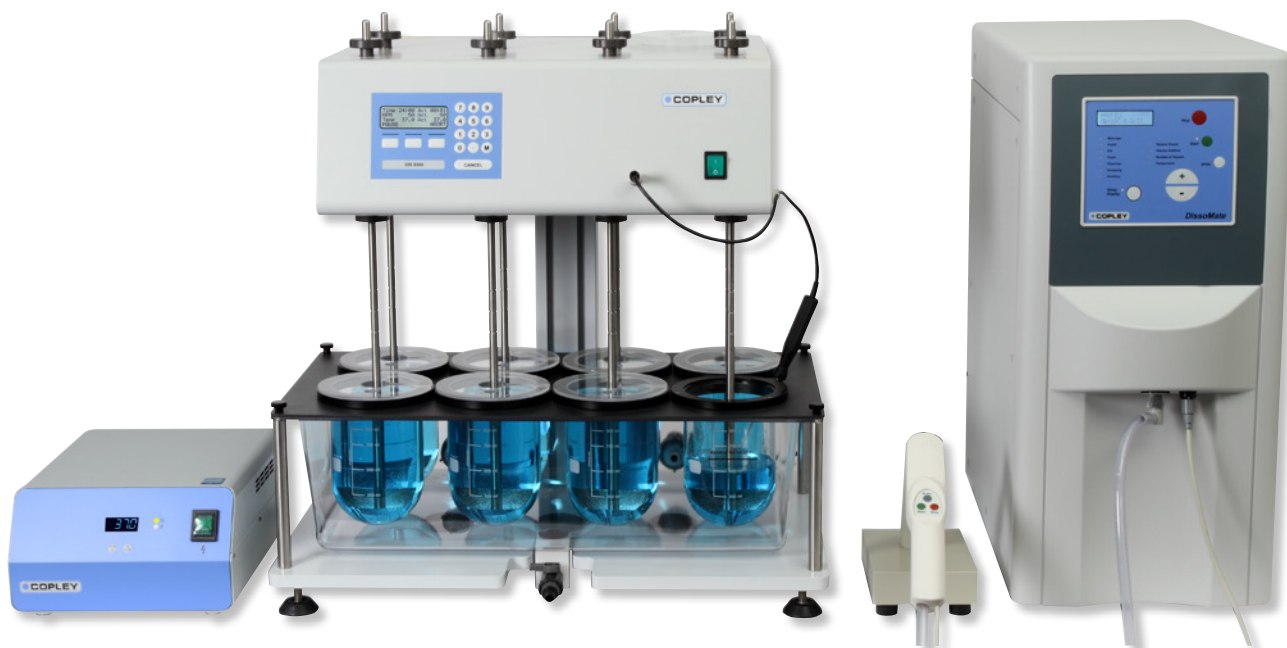

DISSOLUTION TESTER DIS 6000

In many laboratories, bench space is at a premium. The **DIS 6000** has been designed as a direct response to this problem. With a footprint of just 650 x 450 x 640 mm (w x d x h), the DIS 6000 is one of the most compact dissolution testers available on the market today.

The unit has **six stirred test vessels** arranged in two rows of three.

Heating is provided by an **independent digital 1250 W heater/circulator**, which obviates the need for priming and can be quickly removed for cleaning, without compromising the whole tester.

The digital heater/circulator is fitted with a special low vibration impellor which in comprehensive tests has proved to be equal to or less, in terms of vibration measurements than an independent heater/circulator.

A low water level and over temperature cut-out is provided as standard.

A common complaint from customers is that their existing tester is overly complex with unnecessary software functionality for day-to-day use.

For this reason, considerable attention was given in the design to ensuring that the number of actions necessary to perform a test was kept to a minimum. Once the test sequence has been initiated, all that is necessary to start the test is to input the nominal rpm and nominal temperature required, together with the duration of the test and the report interval (the time interval during the test at which the actual rpm and temperature is logged and subsequently reported), introduce the samples and press START.

During the test the following information is shown on the display:

- Nominal and actual rpm
- Nominal and actual temperature
- Preset test duration and time elapsed



Dissolution Tester DIS 6000 ▲

An audible alarm alerts the user that the test is completed.

The dissolution tester is provided with both parallel and USB ports as standard for printout of time, date, bath identification, serial number and date of calibration, together with the speed and temperature at operator selectable time intervals during the test.

A bi-directional RS232 Interface on the back panel allows communication with external devices and incorporation into automated systems.

In all other respects, the Dissolution Tester DIS 6000 is similar in construction to the DIS 8000 described on the preceding pages.



Cat. No. Description

1311	Dissolution Tester DIS 6000 (incl. 6 Drive Shafts)
1302B	Set of 6 Baskets (Ph.Eur./USP Method 1)
1304B	Set of 6 Paddles (Ph.Eur./USP Method 2)
1307	Printer (including USB Cable)
1207	Electronic Temperature Calibration Kit
1309	IQ/OQ/PO Documentation Pack

Extra for Laser Numbering and Certification

See Page 33



EMC Ultra Precision Dissolution Vessel

1	Inside Diameter	101.19 +/- 0.13 mm
2	Inside Spherical Radius	50.59 +/- 0.13 mm
3	Height (Inside Spherical Radius to top)	154.75 +/- 0.50 mm
4	Flange OD	120.00 +/- 0.50 mm
5	Flange Thickness	3.50 +/- 0.50 mm
6	Perpendicularity (Inside Vessel Dia. to Flange Underside)	0.50 mm Max

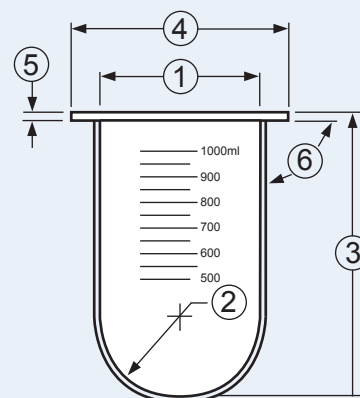

DISSOLUTION TESTER DIS-EMC

If you require the ultimate in a Dissolution Tester then the DIS-EMC is for you.

The **Copley Dissolution Tester Series DIS-EMC** includes all the features of the standard DIS 6000 and DIS 8000 units described on the preceding pages.

The standard versions of the DIS 6000 and DIS 8000 already comply with the new EMC specifications as laid down by the FDA.

Where the DIS-EMC differs from the standard unit is the application of the latest state-of-the-art technologies to the manufacture of the Dissolution Vessel, which in combination with the precision ground stirring element brings you a new level of standard in terms of dimensions and tolerances.

It is the **Dissolution Vessel** in which the dosage form resides during testing and which consequently has the most potential to contribute variability.

Vessel geometry constantly features as a source of concern. A Design of Experiment (DOE) study reported by USP in 2007 (Joseph Eaton *et al.* Perturbation Study of Dissolution Apparatus Variables - A Design of Experiment Approach. Dissolution Technologies, February 2007, Volume 14 Issue 1) found three variables that were statistically significant as far as mean percentage dissolved was concerned: level of deaeration, vessel type and rotation speed.

In the same issue as the article above, USP reported significant differences in the geometric dimensions and surface irregularities of 11 sets of six dissolution vessels selected from 10 commercial sources (Liddell *et al.* Evaluation of Glass Dissolution Vessel Dimensions and Irregularities. Dissolution Technologies).

It is little surprise, therefore, that the key to overcoming instrument induced variability lay in the development of the **EMC Ultra Precision Dissolution Vessel** described in the box above.

Traditionally, dissolution vessels have been made individually using manual glass blowing techniques from extruded glass tubing having a nominal diameter of +/- 2 mm.

The solution was to vacuum form the vessel as opposed to extruding it. In this method, a glass blank is

first heated to 2000 degrees C before being vacuum formed by shrinking it on to a precision ground stainless steel mandrel. This method guarantees an inside diameter tolerance and blemish-free spherical radius of +/- 0.13 mm (compared with +/- 2 mm on the conventional unit) together with a flange perpendicularity tolerance of 0.50 mm TIR (Total Indicated Runout).

If one compares the FDA and USP Enhanced Mechanical Qualification Specifications outlined on Page 23 with the Dissolution Tester DIS-EMC fitted with the new EMC Ultra Precision Dissolution Vessels described above, it can be seen that the DIS-EMC betters the dimensional tolerances specified in the FDA's Enhanced Mechanical Calibration by a **factor of 2**.

All the relevant parts are individually serialised as standard.

Cat. No. Description

1392	Dissolution Tester DIS-EMC 6000
1302B	Set of 6 Baskets (Ph.Eur./USP Method 1)
1304B	Set of 6 Paddles (Ph.Eur./USP Method 2)
1395	Dissolution Tester DIS-EMC 8000
1302A	Set of 8 Baskets (Ph.Eur./USP Method 1)
1304A	Set of 8 Paddles (Ph.Eur./USP Method 2)
1307	Printer (including USB Cable)
1207	Electronic Temperature Calibration Kit
1309	IQ/OQ/PQ Documentation Pack



Tablet Drop (before)



Tablet Drop (after)

AUTOMATIC TABLET DROP

The first procedure at the start of any dissolution test is to drop the samples into the individual vessels.

This function can be performed manually if desired.

Indeed, when using the DIS series of dissolution testers, this is relatively easy since the baths have been deliberately designed to reduce clutter and maximise visibility and access in the critical sampling area above the water bath.

However, this approach does mean employing a staggered start since it is very difficult to introduce all the tablets and then take samples simultaneously.

For this reason, a correction factor has to be applied to the final results in order to take into account the time-lag between introducing the tablets.

When using automated systems, where sampling from all vessels can be performed simultaneously, the dissolution tester can be fitted with an automatic tablet drop system. With this system, the tablets are placed in a series of chambers on the dissolution vessel lids and ejected into the vessels at the same time at the start of the test.

Cat. No. Description

1312A	Automatic Tablet Drop (DIS 8000)
1312B	Automatic Tablet Drop (DIS 6000)

SAMPLING

Four different dissolution sampling systems are available according to user requirements.

The simplest method is to sample from each vessel using a **manual sampling cannula**.

The manual sampling cannula (below) has a **Luer fitting** to accept a 20 mL syringe supplied with it and is bent at the top to allow for easy positioning in the dissolution vessel.



Manual Sampling Cannula ▲

Alternatively, we can offer **resident probes** designed to fit directly into the dissolution lid. Resident probes are designed to be left "in-situ" in the dissolution vessel for the duration of the test - they can, of course, be removed between tests for cleaning.

All of the resident sampling probes are height adjustable to take into account the differences in sampling position required by the differing methods described in the Pharmacopoeias.

Two types of resident sampling probe are available:

1. For manual sampling (with **Luer fittings**).
2. For automated systems: fitted with **Omnifit fittings** and used in conjunction with the return line inserts for use in automated systems.

Note: See Page 32 for probe filters.



▲ Resident Probe with Luer fitting (left) and with Omnifit fitting (middle) together with a Return Line Insert (right)

Cat. No. Description

1313	Manual Sampling Cannula Assembly complete (each)
1314	Resident Probe with Luer Fitting (each)
1315	Resident Probe with Omnifit fitting (each)
1316	Return Line Insert (each)

SPARE PARTS AND ACCESSORIES

Carrying Rack
for 4 Vessels

SUNDRIES

Storage Rack for 8 Baskets
or Paddles

Cat. No. Description

1365	Carrying Case for 8 Baskets/Paddles and Shafts
1339	Carrying Rack for 4 Vessels
1367	Pack of 8 Peristaltic Pump Tubes (Green/Green)
1368	Pack of 8 Peristaltic Pump Tubes (Purple/White)
1369	8-Channel Colour Coded Ribbon Tubing (per metre)
1370	Pack of 10 Connectors
1321	Storage Rack for 8 Baskets or Paddles

PERFORMANCE VERIFICATION
TESTING (PVT)

These standardised drug forms supplied by USP (Rockville, Maryland, USA) have been formulated to produce reproducible results under standard dissolution test conditions.

Thus, if the results using the reference standards prove satisfactory, it can be assumed that the physical and mechanical variables of the system are within the specified limits and that any anomalies are due to the dosage form under test.

USP holds that both mechanical calibration and performance verification testing are necessary to evaluate both USP Apparatus 1 and 2, and neither procedure is sufficient alone.

Cat. No. Description

1373	Pack of 30 Prednisone Tablets - USP disintegrating
1375	Prednisone Reference Standard (250 mg pack)



FILTERS (POLYETHYLENE)

Cat. No. Description

1358	Pack of 50 Filters (20 micron)
1359	Pack of 50 Filters (10 micron)
1360	Pack of 50 Filters (4 micron)

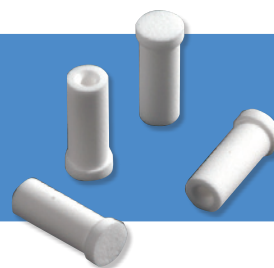
HYGIENE: ANTI-BACTERIAL/ALGAE
TABLETS

Bacterial or algal growth in dissolution tester water baths can be hazardous, malodorous and inconvenient.

The addition of just one mL of Aqua-Stabil per month will prevent the build-up of bacteria and algae keeping the water clear, safe and odour free.

Each bottle contains 100 mL of Aqua-Stabil to maintain the clarity and quality of your water bath systems.

Cat. No. Description

1372	100 mL Bottle of Aqua-Stabil
------	------------------------------



SPARE PARTS AND ACCESSORIES

Dissolution Drive Shaft



Cat. No. Description

DISSOLUTION DRIVE SHAFTS

1329 316 Stainless Steel Drive Shaft only

316 SS Basket

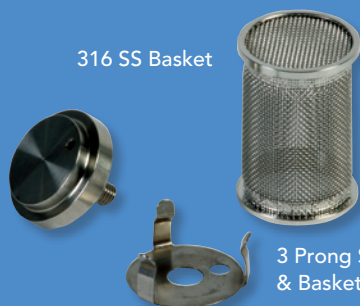
3 Prong Spring
& Basket Holder

BASKET STIRRING ELEMENTS (USP/Ph.Eur. Method 1)

1302 Basket **only** in 316 Stainless Steel (40 Mesh)

1338 Basket Holder in 316 Stainless steel

1336 3-Prong Retention Spring in 316 Stainless Steel

1333 Basket Stirring Element **complete** with Drive Shaft

316 Stainless Steel &
Teflon Coated Paddles

PADDLE STIRRING ELEMENTS (USP/Ph.Eur. Method 2)

1304 Paddle **only** in 316 Stainless Steel

1341 Paddle Stirring Element **complete** with Drive Shaft

1343 Paddle Stirring Element **complete** - Teflon Coated

VESSELS

1346 Vessel, 1000 mL, with **Easy-Centre**

1349 Amber Vessel, 1000 mL, with **Easy-Centre**

1398 EMC Dissolution Vessel, 1000 mL, with **Easy-Centre**

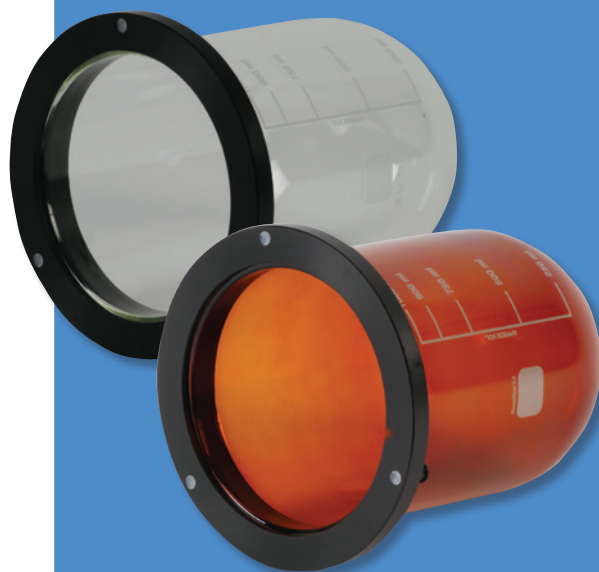
Standard & Amber
Coated Vessels

VESSEL COVERS

1351 Vessel Cover, **Standard**

1353 Vessel Cover, Two-part Membrane Sealed

1355 Plug for Vessel Cover Cat.No.1353

CAPSULE SINKERS AND WEIGHTS

1356 Set of 6 316 Stainless Steel Sinkers

1356A Set of 8 316 Stainless Steel Sinkers

1345 Set of 6 Basket Sinkers (Japanese Pharmacopoeia)

1348 Wire, 316 Stainless Steel (50 ft length)

1357 Set of 6 3-prong Plastic Sinkers

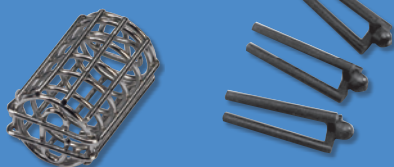
316 SS, Basket &
Plastic Sinkers

LASER NUMBERING AND CERTIFICATION (each)

1332 Certification of 316 Stainless Steel Drive Shaft

1310 Certification of Basket in 316 stainless steel (40 Mesh)

1335 Certification of Basket Stirring Element complete

1318 Certification of Paddle only in 316 Stainless Steel

1342 Certification of Paddle Stirring Element complete

1350 Certification of Vessel, 1000 mL, with **Easy-Centre**

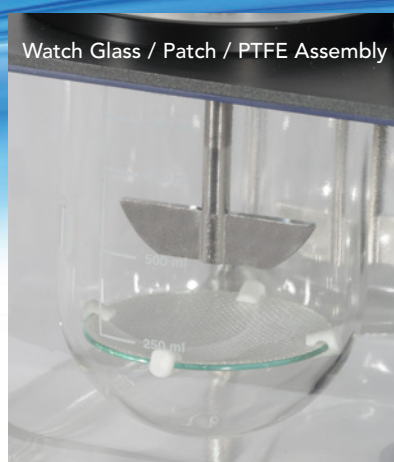

TRANSDERMAL PATCH TESTING (DRUG RELEASE)

PADDLE OVER DISK

The "Paddle over Disk" technique is a modified version of Method 2 (Paddle Method) and is used for the determination of the drug release rate of **transdermal patches**.

It is described in the United States Pharmacopeia (USP) under Chapter <724> as Method 5 and in the European Pharmacopoeia (Ph.Eur.) under Chapter 2.9.4. Method 1 as 'Disk Assembly Method'.

The **standard disk** comprises a 35 mm o.d. 40 mesh stainless steel screen mounted in a stainless steel holder having a diameter of 41.2 mm and is designed to hold the transdermal patch at the bottom of the vessel.

It is suitable for all transdermal patches up to a maximum of 16 mm outside diameter. The transdermal patch is mounted on the disk, release side up, using a suitable adhesive (Hollister Medical Adhesive or equivalent).

A second and larger version of the disk comprising a 90 mm diameter **watch glass-patch-PTFE** assembly is available to accommodate larger patches.

It is this second and larger disk assembly that is normally considered the method of choice since experimentation dictates that this procedure gives almost identical results with that of other, more complicated apparatus.

The assembled disk is placed, with the patch release side up, at the bottom of the vessel, parallel with the bottom edge of the paddle and the height of the paddle adjusted such that its bottom edge is 25 mm from the surface of the disk assembly.

The following parameters are normally considered representative of skin conditions *in vivo*:

- Media pH: 5 to 6
- Media Temperature: 32 degrees C
- Paddle Speed: 100 rpm

ROTATING CYLINDER

An alternative method for the testing of **transdermal patches**, USP Method 6 (Ph.Eur. Chapter 2.9.4. Method 3), employs the same dissolution equipment as USP Method 1, simply substituting a cylinder stirring element in place of the standard basket (see main photos and left).

The rotation speed normally employed is 100 rpm. The element is designed to accept various sizes of patches.

In this method, the protective liner of the transdermal patch is first removed and the adhesive side placed on a piece of inert, porous cellulosic material (Cuprophane Type 150) that is not less than 1 cm larger on all sides than the system.

The assembled system is then attached to the exterior of the cylinder using a suitable adhesive to the exposed borders of the Cuprophane support.

An **extension piece** (see above) is included in the kit for larger patches.



Cat. No. Description

1384	Standard Disk according to USP Method 5
1384A	Watch Glass/patch/PTFE Assembly to USP Method 5
1385	Hollister Medical Grade Adhesive (90 gm spray)
1386	Cylinder Stirring Element including Extension (USP Method 6)
1386B	Height Gauge for Cylinder Stirring Element
1387	Cuprophane Flat Membrane 150 pm (10 Sheets)

SPECIAL APPLICATIONS

INTRINSIC DISSOLUTION

Intrinsic dissolution may be defined as the dissolution rate of a substance under constant surface area conditions.

It is normally measured in terms of *mg per minute per square centimetre*.

It differs from the more conventional dissolution methods in that **only one 7 mm diameter surface is exposed to the solvent** (dissolution media).

The kit for intrinsic dissolution studies is based on the same principles as the **Rotating Disk** apparatus described in USP Chapter <1087> Apparent Intrinsic Dissolution - Dissolution Procedures for Rotating Disk and Stationary Disk.

Both Rotating and Stationary Disk methods share the same characteristics, namely:

- Both rely on compression of the test compound into a compact prior to testing
- Both use a tablet die to hold that compact
- The die is located in a fixed position within the vessel in order to maintain the same hydrodynamic conditions

The Intrinsic Dissolution Kit normally consists of six or eight 7 mm diameter punch and die set kits together with a hand operated press specifically designed to allow the compression of the material into a compact.



Final Assembly prior to placement in Dissolution Tester

Hand Operated Press



The punch and die set kits can be purchased singularly if required.

The compaction process is relatively simple:

- 1) Place the die on to the lower punch (compaction plate).
- 2) Fill the die cavity (the hole in the centre of the die) with sufficient powdered drug to reach the top.
- 3) Use a flat blade or spatula to level off the powder such that the top of the powder is flush with the top of the die.
- 4) Now place the upper punch on to the top of the die locating the punch tip over the sample, and using light pressure from the hand, compact the powder mixture into the hole.
- 5) Then place the entire assembly into the hand operated press, and with the force transmitted to the top of the punch, apply the appropriate pressure (approx. 2 tons) to compact the powder.
- 6) Now release the assembly from the press, remove the die containing the compact and locate it into the three pronged spring holder as shown in the photographs below.
- 7) Finally, screw the assembly on to the dissolution shaft and adjust the shaft such that when in the fully lowered position the surface of the compact is not less than 1 cm from the bottom of the vessel.
- 8) Repeat the exercise for the other assemblies (where applicable).

Rotate the shafts at 200 rpm - the dissolution rate depends on the rotation speed used.



Drive Shaft, Intrinsic Dissolution Assembly and Top Punch

Cat. No. Description

1364	Punch and Die Set Kit (each)
1364A	Hand Operated Press

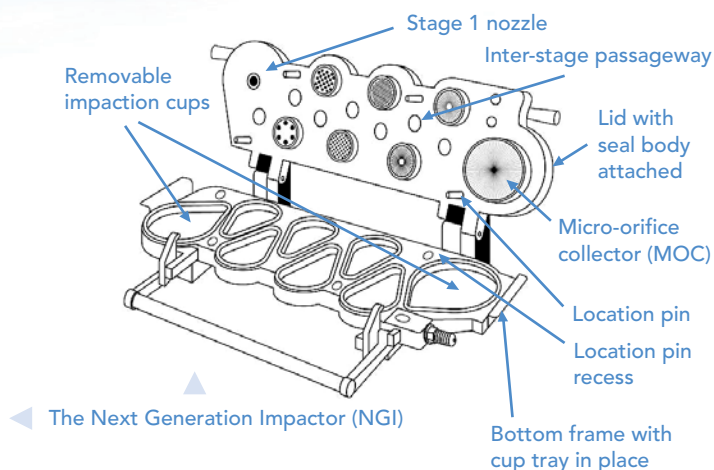

SPECIAL APPLICATIONS - INHALED DRUGS

INTRODUCTION

Dissolution is a critical quality attribute in the development and manufacture of oral dosage forms such as tablets and capsules, which rely on the drug dissolving in the fluids of the gastrointestinal tract prior to absorption into the systemic circulation.

Indeed, dissolution testing is widely used for optimising efficacy during development (often by using modified or controlled release techniques), ensuring quality during batch to batch manufacture and, in some cases, to predict bioavailability *in vivo* and assess bioequivalence.

In the case of inhaled and nasal drug delivery products, the first prerequisite is to deliver an appropriate amount of drug to the target site.

For that reason, *in vitro* testing is concentrated on drug delivery (emitted dose) and lung or nasal deposition (aerodynamic particle size distribution) using a cascade impactor such as the Next Generation Impactor (NGI) or Andersen Cascade Impactor (ACI) as opposed to dissolution or drug release.

Once deposited, the absorption or lung uptake, and hence the therapeutic effectiveness of the drug, depends on the active dissolving in the small amounts of aqueous fluid and lung surfactant available at the target site.

At present, there are no official dissolution test methods described

applicable to inhaled products.

One of the main problems facing the developers of such methods is the identification and segregation of that part of the total emitted dose actually reaching the target site (as opposed to the whole dose) in a form readily adaptable to conventional dissolution testing techniques.



Membrane Holder in Dissolution Vessel ▶

SPECIAL APPLICATIONS - INHALED DRUGS

DESCRIPTION

Based on a concept developed by Professor Jason McConville at the College of Pharmacy, University of Texas, the NGI Dissolution Cup and Membrane Holder incorporates a modification of the standard NGI collection cup.

This allows the size-fractionated particles from an aerosol cloud to be collected and then tested in a conventional dissolution tester.

The Dissolution Cup only differs from the standard cup in that it has a 50 mm removable insert in the impaction area. Particle sizing is carried out in the conventional manner. Once collection is complete, the insert is carefully removed from the cup, covered with a pre-punched 55 mm diameter polycarbonate membrane and secured in position in a Membrane Holder, using a ring, to form a sealed "disk" or "sandwich".

The Membrane Holder can then be placed in a conventional Dissolution Tester such as the Copley DIS 6/8000 and tested in a manner similar to the Paddle over Disk Method described in USP Method 5 and Ph.Eur. 2.9.4 using ca. 300 ml of dissolution medium and the paddle speed at 75 rpm.

A similar technique can be employed using the Andersen Cascade Impactor, in this case, by applying a 76 mm polycarbonate filter to the collection plates prior to analysis, such that the drug is captured directly on the

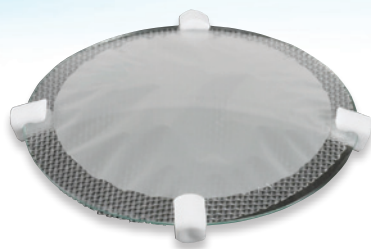

▲ Watchglass/PTFE Assembly for use with ACI

membrane, and then sandwiching the inverted membrane between the glass and PTFE surfaces of the Watch Glass/PTFE Assembly, normally used for transdermal patches.

The small amount of aqueous fluid and surfactant found in the lung makes it extremely difficult to mimic *in vitro*.

Marques, Loebenberg and Almukainzi list five of the most used simulated lung fluids in Table 11* of their article, "Simulated Biological Fluids with Possible Application in Dissolution Testing".

The first of these, SLF1, has been used to evaluate different interstitial conditions in the lung following exposure to various environmental emissions.

▼ NGI Dissolution Cup and Membrane Holder



Cat. No. Description

6001	NGI Dissolution Cup and Membrane Holder (each)
6002	55 mm Punch (for cutting filters to size)
6003	Watch Glass/PTFE Assembly for use with ACI (each)
6004	Pack of 100 Polycarbonate Filters (0.1 micron x 76 mm diameter)



▲ Andersen Cascade Impactor (28.3 L/min Version) with Induction Port

SLF2 was designed to model the interaction of particles with extracellular lung fluids, in this case, exposure to Hg due to the inhalation of airborne calcines from mine waste.

Another fluid replicating interstitial fluid, SLF3, was used to evaluate the *in vitro* release of insulin following pulmonary delivery.

In the method described here, Son and McConville suggested the use of two standardised fluids, described in the article under the designation, SL3, and its modified version, SL4.

Finally, SLF5 was used to measure the dissolution of titanium tritide particles used as components of neutron generators.

*Margareth R.C. Marques, Raimar Loebenberg and May Almukainzi, *Simulated Biological Fluids with Possible Application in Dissolution Testing. Dissolution Technologies (August 2011) p. 15-23.*

SPECIAL APPLICATIONS

SMALL VOLUME CONVERSION KITS

Two conversion kits comprising special low volume vessels of either 100 or 200 mL capacity with appropriate mini-paddles are available for low dose formulations.

Some dosage forms, with small quantities (or extended release) of drug, require much lower concentrations than are usual in the standard 1000 mL vessel.

Each conversion kit comprises:

- 1 x Mini Vessel
- 1 x Mini Paddle
- 1 x Vessel Cover
- 1 x Centring Ring Assembly

A special flat bottomed vessel version of the mini-paddle and vessel is used with the ointment cell, a variation on USP Method 5 suitable for topical preparations such as liquids, suspensions, gels and ointments (see Page 71 for further details).

Small Volume Conversion Kit ▼

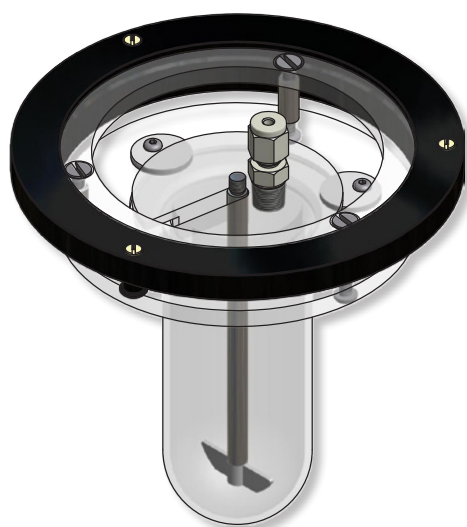

▲ Small Volume Conversion Kit

SPECIAL BASKETS

Some dosage forms have a tendency to block the standard 40 mesh basket and may require the substitution of a basket having a coarser mesh. The mesh size selected should be sufficient to retain the dosage form in the basket whilst allowing media penetration without clogging.

Special Coarse Mesh Basket ▼



BASKET FOR THE DISSOLUTION OF SUPPOSITORIES

Oil based suppositories give unacceptable and unreproducible results utilising the standard 40 mesh stainless steel dissolution basket, since the suppository base has a tendency to block the filter mesh.

The special basket for suppositories has the same basic basket specification as the standard USP basket but is constructed from polyurethane.

The standard sieve mesh is replaced by 12 linear slots of 2.5 mm width providing a porosity of approx. 52% (approximately equivalent to 10 mesh).

◀ Special Suppository Basket

Cat. No. Description

1361	Basket only in 316 Stainless Steel (20 Mesh)
1362	Basket only in 316 Stainless Steel (10 Mesh)
1363	Special Suppository Basket
1371-100	Conversion Kit for Small Volumes - 100 mL
1371-200	Conversion Kit for Small Volumes - 200 mL

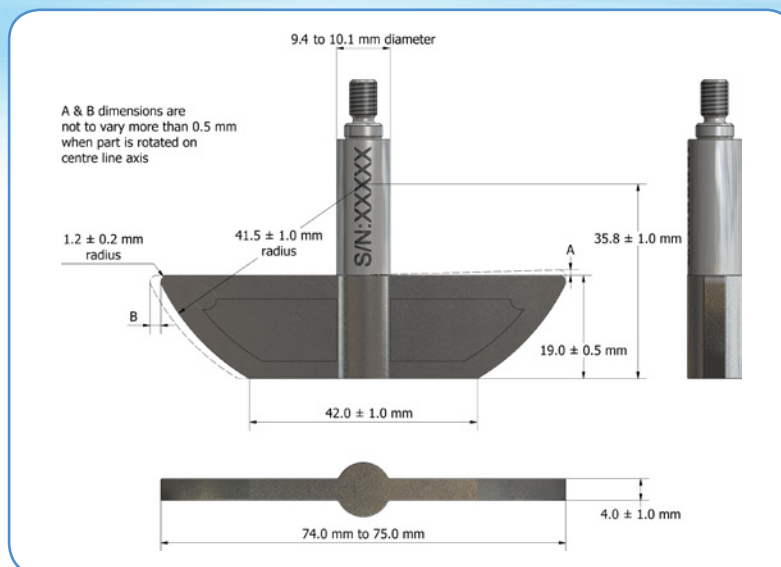
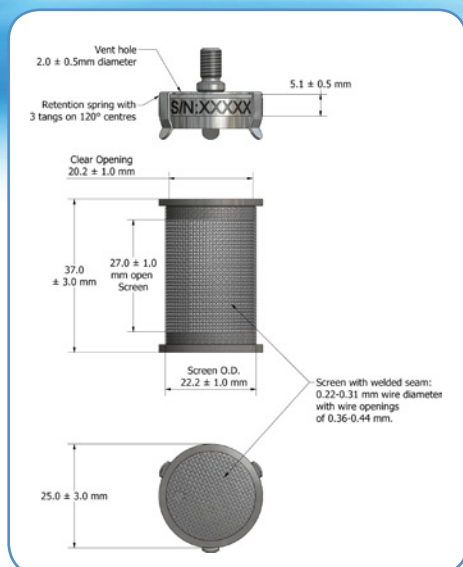

Dissolution Basket and Paddle Specifications (ICH Harmonised Tripartite Guideline Q4B Annex 7 (R2))

CALIBRATION TOOLS

Whether employing the conventional approach to qualification specified in USP Chapter <711> - using a combination of less rigid mechanical checks supported by the traditional Performance Verification Test (PVT) with prednisone - or the more recent FDA approach based on a more rigid series of mechanical checks alone, it is essential that your dissolution tester is checked on a regular basis to ensure that it conforms with the relevant criteria.

FDA's current good manufacturing practice (CGMP) regulations require that "laboratory apparatus be calibrated at suitable intervals in accordance with an established written programme of scheduled procedures (21 CFR 211.160(b)(4) and 211.68)".

Copley Scientific provides a complete range of calibration and qualification tools to ensure that your equipment complies with the appropriate guidance including:

- Speed, Temperature & Vibration
- Horizontal & Vertical Levelling
- Basket, Paddle & Vessel Conformance
- Basket & Paddle Height
- Basket, Paddle & Shaft Wobble
- Vessel Verticality and Centring
- Shaft Verticality



Calibration Kit (see details overleaf)

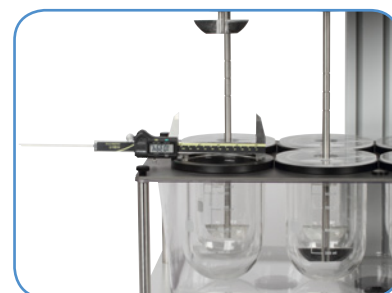

Basket, Paddle & Vessel Conformance



Basket/Paddle Wobble



Vessel Centricity



Horizontal & Vertical Levelling



Shaft Rotational Speed (Tachometer)

CALIBRATION TOOLS



1378



1380



1381



1501

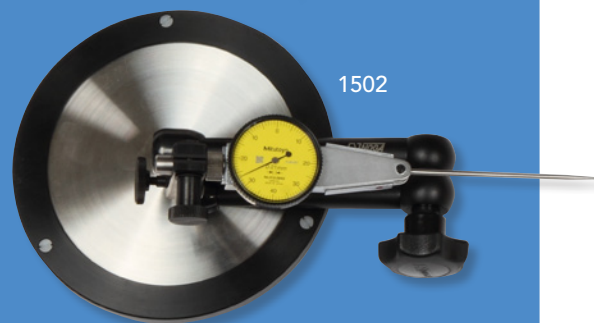

1502



1503



1505

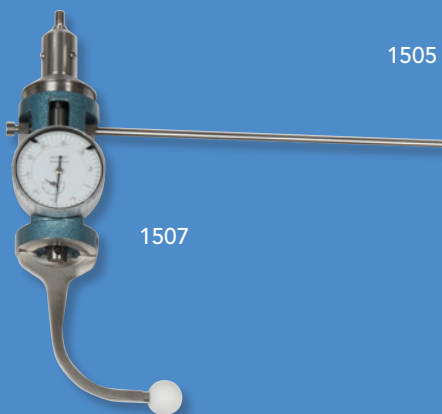

1507

Cat. No. Description

- 1378 Height Checker
- 1380 Temperature Checker (Digital Thermometer)
- 1381 Speed Checker (Tachometer)
- 1501 Digital Caliper Model 500
- 1502 Wobble Checker
- 1503 Level Checker (Spirit Level)
- 1505 Stopwatch
- 1507 Centricity Checker
- 1508 Calibration Tool Kit complete (includes above tools)
- 1509 Verification Rig for Wobble & Centricity Checkers*
- 1320 Vibration Meter*

* Not included in the standard Calibration Tool Kit

Note: All items UKAS calibrated as appropriate.



1508



1509* (shown with 1507)



1320*

MEDIA PREPARATION (DEAERATION - THE PRINCIPLES)

The effects of air bubbles and other dissolved gases in the media used to conduct dissolution tests are legion and can be significant.

A Design of Experiment (DOE) study reported by USP in 2007 (Joseph Eaton *et al.* Perturbation Study of Dissolution Apparatus Variables - A Design of Experiment Approach. Dissolution Technologies. February 2007 Volume 14 Issue 1) found that, of the nine variables and 36 two-factor variables studied, three variables stood out as being statistically significant as far as mean percentage dissolved was concerned: **level of deaeration, vessel type** and **rotation speed**, with the level of deaeration contributing to **52.3%** of the total reported effects.

The major influence of gas or air in dissolution work seems to be physical. Air bubbles may collect on the dosage form, the basket containing the dosage form or the sampling probe or their filters used to draw off samples for analysis. Their presence in spectrophotometer flow cells or on fibre optic probes may lead to incorrect absorbance readings. They may also accumulate on the membranes employed in the vertical diffusion cells used in transdermal and percutaneous absorption tests.

Dissomate with
Dissolution Tester

THE REGULATIONS

The Pharmacopoeias recognise that "dissolved gases in the dissolution medium may affect dissolution test results" and recommends that gases be removed before the test is performed.

They advocate the following procedure as one method of deaeration:

"Heat the medium, while stirring gently, to about 41 degrees C, immediately filter under vacuum using a filter having a porosity of 0.45 microns or less, with vigorous stirring and continue stirring under vacuum for about 5 minutes".

This "**filtering, warming and stirring under vacuum**" approach is echoed by the FDA (Terry W. Moore. Dissolution Testing: A Fast, Efficient Procedure for Degassing Dissolution Medium' Dissolution Technologies. May 1996).

The Pharmacopoeias also state "Place the **stated volume of the the Dissolution Medium (+/- 1%)** in the vessel of the specified apparatus given in the individual monograph, assemble the apparatus, equilibrate the Dissolution Medium to 37 +/- 0.5 degrees C, and remove the thermometer".

Note: Chapter <1092>, USP 38, 1st Supp., now specifically recommends a dissolved oxygen level of > 6 ppm.

The temperature of the medium is critical to volumetric precision. The volume of the dissolution medium at the stated temperature of 25 degrees C is different for that at 37 degrees C, at which point the volume would be greater because the medium expands as the temperature rises.

It is for this reason that USP suggests that a more accurate and temperature independent measure of the media volume is gravimetric, i.e. by **weight**.

USER REQUIREMENTS

In addition to conformity to the compendial and regulatory requirements, there are a number of user requirements which must be taken into account:

- Simple, easy-to-use operation
- Proven time savings in comparison with manual methods
- Compact (space saving)
- Accurate and reproducible
- Capable of validation

Dissomate Media Station

Warms	✓	Weighs	✓
Deaerates	✓	Dispenses	✓

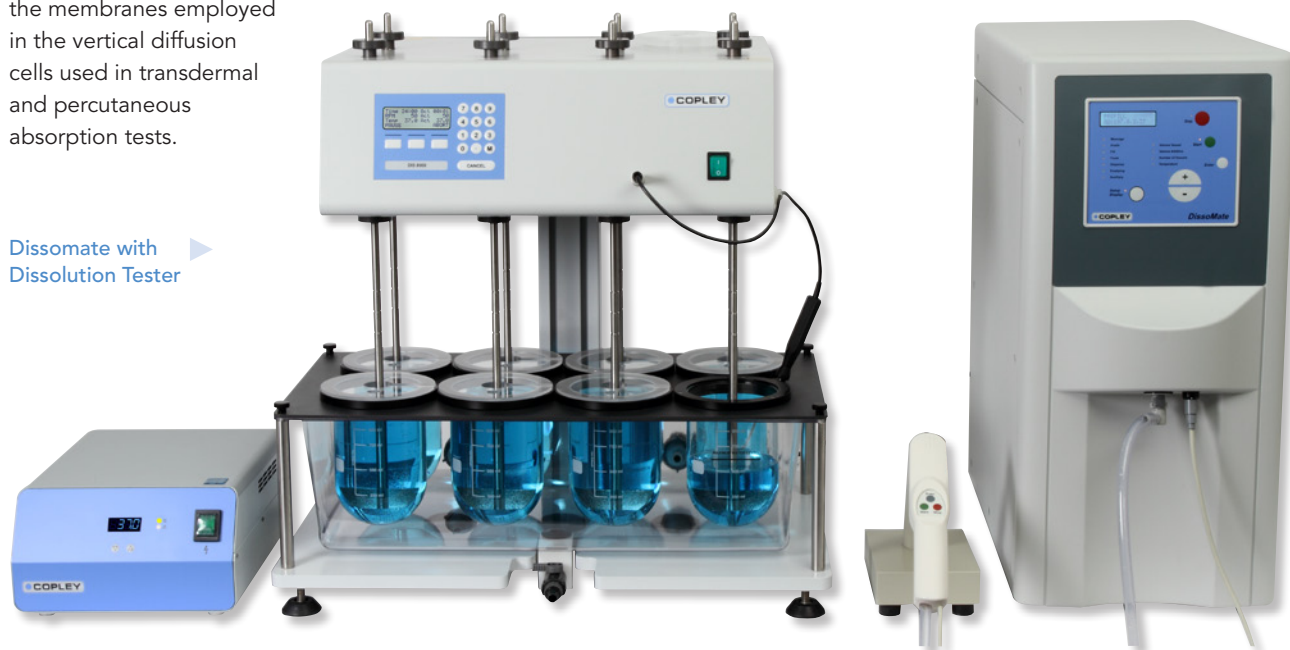



Dispense Nozzle ▲

DissoMate Protocol Printout ►

DissoMate Operation Manual, ID 2009519 Rev 7.115, 2012-08-02
J-47-6-Operation

6.5.4.1 Sample of a MEDIA DISPENSE PROTOCOL

MEDIA DISPENSE PROTOCOL
No: 14

DissoMate Copley Scientific Limited
Serial Number : R29090999
Firmware Version: 7.000

General Data:
Nominal filter capacity [l]: 5000
Remaining filter capacity [l]: 4827
Volume throughput up to now : 173

Method: 0
900, 0.0, 6, 37.0

Result of the dosages [g]:

	MEDIUM	ADDTV	RATIO	DEV%
Fill Nominal:	5400	0.0	0.000	
Fill Actual:	5504	0.0	0.000	+0.0

	MEDIUM	DEV%	ADDTV	DEV%
Vessel No. 6:	899	-0.1	0.0	+0.0
Vessel No. 5:	901	+0.1	0.0	+0.0
Vessel No. 4:	900	+0.1	0.0	+0.0
Vessel No. 3:	900	-0.0	0.0	+0.0
Vessel No. 2:	900	+0.0	0.0	+0.0
Vessel No. 1:	900	-0.0	0.0	+0.0

Temperature (average): 37.1 C
MAX.VACUUM at 89 mbar absolute pressure

Date, Time:
Name:
Signature:

MEDIA PREPARATION - THE DISSOMATE

The DissoMate Media Preparation Station Model X8 combines degassing and dispensing to provide a fresh source of pre-warmed, deaerated and dosed dissolution medium, thus substantially reducing down times between dissolution tests.

There is no necessity to premix the dissolution medium in advance. The DissoMate automatically adds the appropriate volume of acid, buffer or surfactant to the prewarmed medium prior to mixing and dispensing.

PRINCIPLE OF OPERATION

The principle of operation is extremely simple. The DissoMate operates on the same **"filtering, warming and stirring under vacuum"** approach as recommended by the Pharmacopoeias and FDA.

On initiation the dissolution medium is withdrawn under vacuum from the media reservoir (**not** provided) through the heater, which warms the medium to the desired temperature and into the polypropylene mixing chamber.

An easily exchangeable filter cartridge located in-line within the fill tube filters the medium prior to use.

Tip: A single DissoMate could possibly service all of your Dissolution and Disintegration Testing needs

The life of the filter is constantly monitored in terms of total elapsed volume filtered and the user prompted to change the filter when required. The default setting is 5000 litres.

The medium is preheated to the appropriate temperature (adjustable between 20 and 45 degrees C in 0.1 increments) en route to the mixing chamber by means of a special continuous-flow water heater, before degassing takes place. This enhances the degassing process and saves considerable time in testing.

If the "Additive" function has been selected, then the acid, buffer or surfactant is automatically added to the mixing chamber at this point. Dilution ratios of between 1:3 and 1:100 can be accommodated.

An in-built magnetic stirrer ensures a homogenous mix within the mixing chamber (Accuracy: < 0.5%, typically < 0.2%).

The efficiency of the degassing process is dependent on:

- the vacuum applied, in this case, <250 mbar (typically 95 mbar) pressure absolute
- the time the medium is exposed to the vacuum
- the temperature of the medium
- the stirring of the medium

All of these factors assist in the deaeration process. In the case of the DissoMate, the interaction of heating,

mixing and degassing generates a typical effective deaeration level of 3-5 ppm dissolved oxygen (measured after filling into the vessel).

The mixing chamber of the X8* has a maximum total capacity of 11 litres. This allows for 8 litres of **fresh** medium (sufficient to fill all the vessels of one dissolution bath) plus an additional 3 litres (to accommodate the dead volume created by the tubes, etc., and also provide a flush sequence at the start of the dispense cycle).

Note: The importance of fresh medium cannot be overestimated. An investigation into the overnight reaeration of unused, previously deaerated media found that the concentrations of dissolved oxygen almost doubled during the period concerned (Owen S. Degenhardt *et al.* Comparison of the Effectiveness of Various Deaeration Techniques. Dissolution Technologies. February 2004).

The prewarmed and deaerated medium is dispensed directly into the dissolution vessels by means of a hand-held dispense nozzle (Dispense rate: 2 L/min/Accuracy < 1%).

***New:** A second and larger unit, the X15, which allows for 15 litres of fresh medium sufficient to serve two baths is now available as an option.

DissoMate with Disintegration Tester ▶

MEDIA PREPARATION - THE DISSOMATE

It typically takes 15 minutes from start to prepare eight litres of medium and about 30 seconds per vessel to dispense. This means that a single DissoMate will handle several dissolution testers concurrently.

Accuracy is paramount in any drug release study. One of the unique features of the DissoMate is that both fill and dispense volumes employed are determined gravimetrically, i.e. by weight, using the in-built load cell provided for this purpose. Different media have different volumes dependent on their temperature and pressure conditions - only weight remains constant under such changing conditions.

The use of a load cell means that all the processes involved can be documented and output to an external printer or PC. The DissoMate provides a full report giving details of weights, mixing ratios, vacuum and temperature after each Dispense Cycle. A "Calibration" protocol is also provided.

Extremely compact, the DissoMate measures 30 x 59 x 66 cm (w x d x h) and weighs 26 kilos.



OPERATION

Immerse the inlet tubes from the DissoMate into the medium and additive (if used) reservoirs.

Set Up

Volume Vessel - Enter the weight of the volume of medium to be dispensed into each vessel e.g. 897 g = 900 ml per vessel. (Range = 150 g to 8 kg).

Volume Additive (if used) - Enter the weight of the volume of additive to be dispensed into each vessel, e.g. 10 g.

Number of Vessels - Enter the number of vessels to be filled, e.g. 6 or 8.

Temperature - Enter the media temperature required, e.g. 37 deg. C

Press START key to save as the primary method.

DissoMate Media Station

Warms	✓	Weighs	✓
Deaerates	✓	Dispenses	✓

Preparation

Press START key.

- *Prefill*

Unit prefills system with sufficient medium to prime it.

- *Fill*

Unit fills the mixing chamber with the selected volume(s) of media = $Vessel\ Volume \times Number\ of\ Vessels$. The prewarming and degassing are performed at this stage.

Dispense

Position the hand-held dispense nozzle over a waste container and press the START key.

- *Flush*

Unit flushes out and primes the dispense tube.

- *Dispense*

Position nozzle over first dissolution vessel and press ENTER. Unit dispenses appropriate volume into vessel. Repeat for remaining vessels. Unit returns to *Fill* Mode.

- *Print*

Unit prints out report.

Separate functions are available for *Emptying*, *Autowashing* and *Calibration*.



Cat. No. Description

1322	DissoMate Model X8
1514	DissoMate Model X15
1323	Printer (including cable)
1324	Validation Logbook
1510	Manual Validation Tools
1515	Automated Validation Tools



▲ Typical "Off-Line" System including Dissolution Tester DIS 6000, DissoMate Media Prep Station and DissoFract Sampling System

AUTOMATION

INTRODUCTION

The acceptance criteria quoted in the USP Chapters on Dissolution and Drug Release mean that a minimum of six and possibly up to 24 individual tests may be required per batch of formulation in order to meet pharmacopoeial requirements. Furthermore, the increasing use of extended and delayed-release preparations means that such tests may extend over 12, 24 hour or longer periods.

These demands, together with the rise in multi-point testing brought about by the need for *in vitro* - *in vivo* correlation, mean that the dissolution or drug release test has now become one of the most common analyses employed in the pharmaceutical industry.

Manual dissolution testing is time consuming and labour intensive. As a result, an increasing number of laboratories are turning to automated tablet dissolution systems as a means of improving efficiency and reproducibility.

The advantages of automated systems are well documented, i.e. improved methodology, accuracy, reproducibility and throughput, better use of human resources, etc.

One should balance against these advantages the costs involved in setting up, programming, validating, operating and most importantly maintaining the automated system concerned, for example, in the event of breakdown.

Semi-automated systems that sample, filter, collect or UV/HPLC analyse can provide a valuable trade-off between manual and fully automated systems.

These can be classified into three categories:

1. "OFF-LINE" SYSTEMS (COLLECT ONLY)

Normally comprise a sample collector containing test tubes or vials, a peristaltic or syringe pump to provide the motive force to transport the samples from the dissolution tester to the collector and a PC and interface box to control the system during operation.

The principle of operation is simple - medium from each of the dissolution vessels is circulated via an 8-line peristaltic pump through eight switching valves prior to being returned to the dissolution vessel.

At user-defined intervals the valves operate, diverting a preset volume of sample into the sample collection lines, whereupon the samples are dispensed into either test tubes or open HPLC vials (or injected directly into sealed septum vials by means of an electrically operated vial piercing head provided for that purpose).

The pump is then reversed to clear the sampling lines prior to the next sampling interval, whereupon the operation is repeated. The whole operation is controlled and monitored by a PC. The exact status of the test at any given time can be determined from the software.

In the case of test tubes, the samples must be handled manually, for example by presenting them to the sipper accessory of a suitable spectrophotometer.

HPLC vials containing samples can be removed at any time and placed directly into an HPLC Autosampler.

This version is particularly useful where analytical techniques other than UV/Vis or HPLC are employed or where the samples require a degree of manipulation, for example, to be diluted or mixed with a reagent prior to analysis.

AUTOMATION

2. "ON-LINE" DISSOLUTION SYSTEMS (UV/Vis)

Traditionally based on continuous flow methods, "on-line" dissolution systems incorporating UV/Vis analysis are understandably the most popular approach to automated dissolution testing.

Such systems are simple, clean, easy to set up and maintain.

With this technique, medium from each individual test vessel is circulated continuously through each of a series of flow cells (nominally six to eight) located in the cell compartment of a suitable UV/Vis spectrophotometer by means of a peristaltic pump.

A cell changer mechanism moves each cell in turn into the light beam of the spectrophotometer and the absorbance of each solution is measured. Measurements are made at user-specified intervals. The whole system is controlled by an external PC whose software collects and analyses the results. For highly absorbing drug formulations, the systems can be supplied with 1, 2 or 5 mm pathlength flow cells in place of the standard 10 mm giving effective dilution ratios of 10:1, 5:1 and 2:1 respectively.

The choice of spectrophotometer will depend to a large extent on cost and the degree of sophistication required, i.e. single beam, double beam, etc.

Most UV/Vis continuous flow systems come "ready-to-run" and are particularly easy to use, the operator being guided throughout the performance of the test by a series of on-screen prompts.

3. "ON-LINE" DISSOLUTION SYSTEMS (HPLC)

Although UV is suitable for the analysis of the high proportion of drugs which exhibit active chromophore activity, in the case of certain dosage forms this approach is not practical. Furthermore, many formulations contain multiple components or excipients, or coatings that interfere with UV analysis.

In these cases, **High Pressure Liquid Chromatography (HPLC)** may well provide the solution. The excellent specificity of HPLC makes it more sensitive than UV/Vis techniques for the analysis of sustained release products and of low dosage formulations.

However, these techniques tend to bring a new set of problems.

Many of these problems emanate from the fact that the samples are collected in multiples of six, seven or eight simultaneously, whereas the HPLC detector will only accept samples one at a time.

Furthermore, the time taken to perform the test may prohibit the immediate "on-line" HPLC analysis of the collected samples; that is to say, there is insufficient time between the dissolution sampling intervals to allow for the analysis of six to eight samples.

Modern "on-line" HPLC systems are specifically designed to meet this eventuality in so much that the sampling station acts simply as a temporary storage vehicle for the dissolution samples; the collected samples are then aspirated sequentially to the appropriate detector.

Such systems provide for maximum flexibility in the sample/inject control sequence, allowing separate timing of sample withdrawal and analysis whilst optimising throughput.

Our technical staff will be happy to discuss the various options available to you.

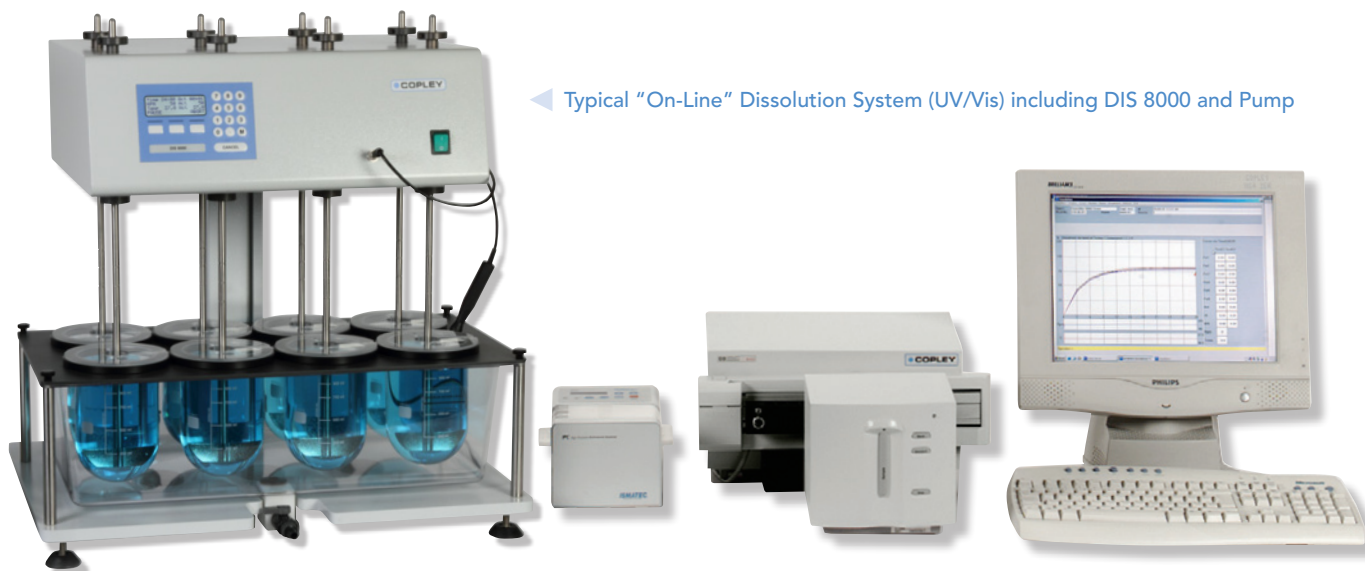

◀ Typical "On-Line" Dissolution System (UV/Vis) including DIS 8000 and Pump



"Off-Line" Dissolution System comprising Dissolution Tester DIS 6000 and DissoFract Sampling System

AUTOMATION - THE DISSOFRACT

INTRODUCTION

The DissoFract is an "off-line" dissolution sampling system specifically designed to automatically remove samples from either six or eight dissolution vessels at predetermined time intervals and deposit them in test tubes or HPLC vials for subsequent analysis (see No.1. on Page 44).

The system employs a series of six or eight dedicated bidirectional small volume diaphragm pumps (one per line/vessel) to facilitate the *flush-sample-purge* functions.

As well as being extremely accurate (Volumetric Precision < 0.25 mL, typically 0.1 mL), the bidirectional pumps have a number of advantages over the more conventional peristaltic or syringe pumps employed in such systems, namely:

- First In/First Out (FIFO) principle
- Low dead volume
- Eliminates need for media replacement
- Low cross contamination
- Short sampling interval times (2 min)

The First In/First Out (FIFO) principle employed in the system is the same as that found in manual testing.

The low dead volumes employed in the system ensure that flush, sample and purge times are kept to a minimum, whilst flush media recycling makes media replacement obsolete and dissolution calculations simple. Cross contamination is <1% at two minute sampling intervals.

The short interval time is particularly important when testing quick release formulations in so much that it allows sampling at intervals hitherto unachievable by more conventional methods.

The user interface is simple, functional and easy to use.

The unit is supplied as standard with two collection racks, one to accept 2 mL HPLC vials and the other 8 mL test tubes.

Each rack accommodates 10 rows of 8 lines and an additional row with test tubes for waste.

In order to eliminate any cross contamination, the standard sampling procedure is always *flush-sample-purge*.

The DissoFract has three main menus:

1. Start menu (the START button)
2. Method menu (the SET UP button)
3. Functions menu (the ENTER button)

1. START MENU

The Start menu is activated by pressing the START button.

This allows you to select and run a previously stored method.

The system first checks to ensure that the correct rack has been loaded into the collector to meet the method requirements.

It then checks to ensure that the sample lines are clear and initiates a purge if this is not the case.

The message now appears "start dissolution". The sampling process is initiated by pressing the START button.

During sampling, the number of the next step, the elapsed time and the remaining time to the next step are indicated on the display.

At the end of the sampling process, a message appears on the display to indicate that the method has been completed and the sampling protocol automatically stored and printed.

AUTOMATION - THE DISSOFRACT

2. METHOD MENU

The Method Menu is activated by pressing the SET UP button.

The Method entry comprises two parts - an initial part relating to the system parameters to be employed and a second part relating to the actual sampling procedure to be followed.

The **System Parameters** comprise as follows:

- *Rack Type*: Vials or Test Tubes
- *Lines*: No. of sample lines/vessels
- *Collection Flow Rate*: 1-15 mL/min
- *Flush Volume*: 1-8 mL
- *Purge Flow Rate*: 1-15 mL/min
- *Stagger Interval*: The required interval between lines when employing staggered starts (0-99 sec)
- *Double Sampling*: Samples into two rows at each step
- *UV/HPLC Transfer* (Option)
- *UV/HPLC Transfer Volume* (Option)
- *Rack Cooling/Heating Temperature*: (5-37 degrees C). Only available with Peltier option

Once the System Parameters have been entered correctly, the ENTER button is pressed in order to set up the **Sampling Procedure** required:

- *Step*: Selects the Step Number.
- *Time - Seconds*: Time in seconds
- *Time - Minutes*: Time in minutes
- *Time - Hours*: Time in Hours
Note: Maximum is 99:59:59
- *Collection Volume*:
Vials - 0.1 - 1.8 mL in 0.1 digits
Tubes - 0.5 - 8.0 mL in 0.5 digits

Press the START button.

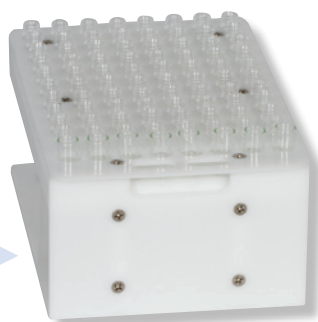

Vial Rack ▶

3. FUNCTIONS MENU

The Functions Menu is activated by pressing the ENTER button.

This provides access to no less than eight separate sub-menus:

3.1 Print Menu

Used to print (a) Test (b) Performance and (c) Calibration Protocols as well as Method Data.

3.2 Purge

Empty all lines back to the vessels/backflush.

3.3 Flush

Perform a manual flush to flush out the system.

3.4 Single Sample

Perform a single sample.

3.5 Autowash

Regular cleaning procedure designed to keep the system in good working order.



▲ DissoFract open to illustrate sample needles and collection rack

3.6 Drying

Used in conjunction with the Peltier Rack Cooling/Heating option to reduce condensate following cooling.

3.7 Calibration Menu

Complete guidance on the IQ/OQ/PQ procedures required to validate and document your system.

3.8 System Menu

Allows you to set up your system parameters in order to meet your own individual needs. The DissoFract measures 30 x 58 x 35 cm (w x d x h) and weighs 23 kg.

◀ DissoFract Sampling System

Cat. No. Description

1325	Set of 6 Resident Probes with Omnifit fitting
1326	DissoFract 6-Line Sampling System
1327	Additional Lines incl. Resident Probe - max. 8 (each)
1513	Pack (of 50) 45 Micron Filters for special probes
1328	HPLC Vial Rack (spare)
1511	Test Tube Rack (spare)
1330	Printer (including USB cable)
1319	Validation Logbook
1512	Validation Tools