

# **Diving Operations from Vessels Operating in Dynamically Positioned Mode**



**The International Marine Contractors Association (IMCA) is the international trade association representing offshore, marine and underwater engineering companies.**

IMCA promotes improvements in quality, health, safety, environmental and technical standards through the publication of information notes, codes of practice and by other appropriate means.

Members are self-regulating through the adoption of IMCA guidelines as appropriate. They commit to act as responsible members by following relevant guidelines and being willing to be audited against compliance with them by their clients.

There are two core activities that relate to all members:

- ◆ Competence & Training
- ◆ Safety, Environment & Legislation

The Association is organised through four distinct divisions, each covering a specific area of members' interests: Diving, Marine, Offshore Survey, Remote Systems & ROV.

There are also five regional sections which facilitate work on issues affecting members in their local geographic area – Asia-Pacific, Central & North America, Europe & Africa, Middle East & India and South America.

### **IMCA D 010 Rev. 3**

This guidance has been produced under the direction of the IMCA Diving Division Management Committee.

This document supersedes all previous versions of IMCA D 010 published since January 1998, with are now withdrawn.

**[www.imca-int.com/diving](http://www.imca-int.com/diving)**

*The information contained herein is given for guidance only and endeavours to reflect best industry practice. For the avoidance of doubt no legal liability shall attach to any guidance and/or recommendation and/or statement herein contained.*

# Diving Operations from Vessels Operating in Dynamically Positioned Mode

IMCA D 010 Rev. 3 – May 2008

Since the 1970s it has been common practice to carry out diving operations from vessels operating in dynamic positioning (DP) mode. During this time several documents have been published which give guidance on ways of achieving safe operations using this system (see bibliography).

Accidents and incidents have occurred world-wide resulting in injury and death of divers and IMCA considers that a comprehensive document is required giving guidance on aspects of diving operations from DP vessels.

This guidance note, which supersedes earlier versions issued since 1998, gives advice which is applicable anywhere in the world and to any type of diving operation. In certain countries there may be regulatory requirements which should always be complied with first, followed by the advice in this document.

<b>I</b>	<b>Introduction .....</b>	<b>I</b>
1.1	Scope .....	I
1.2	Objectives.....	I
1.3	Application .....	I
1.4	Variations.....	I
1.5	This Revision.....	I
<b>2</b>	<b>Responsibility and Authority of Personnel .....</b>	<b>2</b>
2.1	Vessel Masters.....	2
2.2	DP Operators .....	2
2.3	Senior Diving Supervisors and Diving Superintendents .....	2
2.4	Diving Supervisors and Life Support Supervisors .....	2
2.5	Client’s Representative .....	2
<b>3</b>	<b>Safety Management.....</b>	<b>3</b>
<b>4</b>	<b>Marine Interface.....</b>	<b>4</b>
4.1	General Principles .....	4
4.2	Isolation of Thrusters or Propellers.....	4
4.3	Resumption of Diving Activities .....	4
4.4	Vessels in Close Proximity.....	4
<b>5</b>	<b>DP Alert Responses.....</b>	<b>5</b>
5.1	Green – Normal Operational Status.....	5
5.2	Yellow – Degraded Operational Status.....	5
5.3	Red – Emergency Status .....	5
<b>6</b>	<b>Vessel Movement Limitations.....</b>	<b>6</b>
<b>7</b>	<b>Umbilicals .....</b>	<b>7</b>
7.1	Safety Principles .....	7
7.2	Identification of Hazards.....	7
7.3	Main Services Umbilical Safety .....	7
7.4	Excursion Umbilical Safety .....	8

7.5	Deployment of the Excursion Umbilical.....	9
7.6	Use of Negatively Buoyant Umbilicals .....	9
7.7	Deployment of Divers Using In-Water Tending Points .....	9
<b>8</b>	<b>Shallow Water .....</b>	<b>13</b>
8.1	Limitations.....	13
8.2	Vessel Draught.....	13
8.3	Vessel Capability.....	13
8.4	Position References .....	13
8.5	Environmental Conditions .....	14
<b>9</b>	<b>Diving Within an Anchor Pattern.....</b>	<b>15</b>
9.1	Safety Principles .....	15
9.2	Mooring Line Identification .....	15
9.3	Mooring Line Adjustments.....	15
9.4	Permit-to-Work and Reporting Procedures.....	15
9.5	Minimum Operating Clearance.....	15
9.6	Position References .....	16
9.7	Operational Plots .....	16
<b>10</b>	<b>Subsea Structures and Wellheads .....</b>	<b>17</b>
<b>11</b>	<b>References .....</b>	<b>18</b>

# **I Introduction**

## **I.1 Scope**

This guidance addresses the operational aspects of air, nitrox or saturation diving activities performed from dynamically positioned (DP) vessels. It does not address marine matters that are the subject of other guidance, viz. *Guidelines for the design and operation of dynamically positioned vessel* (Ref. 1). Where diving and marine operations interface, information is repeated in this document for the convenience of users.

## **I.2 Objectives**

The objectives are to ensure that:

- i) valid and reliable controls are in place;
- ii) personnel are competent to discharge their responsibilities in a safe and effective manner.

This document is designed to achieve these objectives by providing diving contractors, vessel masters and clients with operational guidance that is based on sound safety principles and which highlights the need for:

- ◆ an adequate safety management system;
- ◆ hazard identification and an appropriate level of risk assessment;
- ◆ approved working procedures;
- ◆ adequate briefings before operations begin.

The guidance covers all aspects of diving operations within the scope (see section I.1) and also takes into account other relevant guidance and the current status of vessel and operational technology.

## **I.3 Application**

This guidance is applicable world-wide and should be used in addition to any relevant national regulations.

## **I.4 Variations**

It may be necessary or appropriate to vary from the guidance given here for operational reasons, e.g. to cater for different vessel characteristics, or to meet the objectives in a more effective way by exploiting technological advances. All variations should, however, embrace the general safety principles reflected in this guidance, and should always be evaluated and agreed during a review of the risk assessment by all relevant parties before implementation.

## **I.5 This Revision**

Rev. 3 of IMCA D 010 supersedes Rev. 2 dated July 2000. The changes mainly cover increased emphasis of the risks of diving within anchor patterns with changes to section 9. Some minor changes have been included in sections 3 (Safety Management), 7 (Umbilicals) and 8 (Shallow Water) to provide further clarification and to make the document easier for the reader.

## **2 Responsibility and Authority of Personnel**

The legislation that gives authority to the masters of merchant vessels or the supervisory staff of diving operations, projects and offshore installations takes precedence over this guidance. It is, however, fundamentally important that the responsibility and authority of each person involved with the management of diving operations from DP vessels be clearly defined.

Detailed responsibilities, other than those defined in legislation, should be defined by the relevant ship owner/operator, diving contractor and client. The guidance provided below should be interpreted for each individual.

### **2.1 Vessel Masters**

The master of a vessel is ultimately responsible for the safety of the vessel and all personnel working on or from it. He can veto the start, or order the termination, of a diving operation through the diving supervisor.

### **2.2 DP Operators**

The DP operator (dynamic positioning control system operator) in charge of the DP system must be suitably trained and experienced (Ref. 2). The DP operator is responsible for the station-keeping of the vessel, and must keep the other relevant control centres of the vessel informed of changes in operational conditions and circumstances, e.g. dive control (see section 5).

### **2.3 Senior Diving Supervisors and Diving Superintendents**

Some diving projects will have a senior diving supervisor or diving superintendent who is an experienced diving supervisor. He will normally act as an offshore project manager, and will ensure that the specifications of the diving project are met. He will also liaise with the vessel master and the client's representative. Other diving supervisors report to the senior diving supervisor or diving superintendent, but they retain the responsibility for the start, operation and termination of the dive that they are supervising.

### **2.4 Diving Supervisors and Life Support Supervisors**

The supervisor on duty is responsible for all the safety aspects of the part of the diving operation for which he is appointed, i.e. diving or life support, including the condition and operation of all relevant equipment. He must be issued with a letter of appointment that details his specific functions.

Diving supervisors and life support supervisors are responsible for the effective and timely conduct of diving and chamber operations as appropriate. They report to the diving superintendent or senior diving supervisor, if one is appointed. The diving supervisor is the only person who may order the start of a diving operation.

The diving supervisor is also responsible for advising the DP operator of any status change in the diving operation.

### **2.5 Client's Representative**

The client's onboard representative is responsible to the client for ensuring that the project specification is carried out in accordance with the diving procedures as detailed by the diving contractor and he should liaise with the contractor's senior representative on-board accordingly. He may request, but not order, the start of diving operations and has the authority to veto the start, or order the termination of diving operations through the diving supervisor.

### 3 Safety Management

Modern safety management is based on work being effectively evaluated, planned and assessed for hazards before it begins. This principle is widely enforced by legislation which, in some geographic areas, can be interpreted and applied with the aid of guidance and codes of practice.

Guidance and codes of practice should be used when setting up and implementing a safety management system. The system should also include the following steps, which must be completed before an offshore diving operation begins:

- ◆ Evaluation, planning and risk assessment should be carried out by the vessel master, the diving superintendent and other specialist personnel as appropriate. The work scope should be considered and provisions made for all foreseeable emergencies, e.g. DP failure, diver rescue, etc. The likelihood of a vessel suffering a total loss of power (a blackout) is recognised to be less than the likelihood of an unplanned 'drive-off'. 'Drive-off' investigations have revealed that these incidents are often as the result of operator error and/or position reference system failure. Consideration should be given both to raising operator awareness and to the selection and use of reference systems in mitigation of the risks;
- ◆ The significant findings of the risk assessment should be recorded, either in writing or electronically, and should be readily accessible and effectively communicated to all personnel involved;
- ◆ There should be a system in place to manage any procedural or environmental changes during operations. The effects of any change should be evaluated against the original risk assessment to ensure that the proposed change is practicable and that new risks are not being introduced. Both the evaluation and the change should be recorded in writing or electronically;
- ◆ The safety critical principles given within this guidance should be incorporated into the risk assessment (see also section 1.4). Other important factors that should be considered are listed below, but it should be noted that this list is only provided as an aid and is not definitive:
  - The interface between contractor, client, installation and/or other vessels
  - Simultaneous operations, e.g. different contractors working within the same field, working within the 500m zone, etc.
  - Availability of a monitoring ROV throughout the operation (Ref. 3)
  - Safe access to and egress from the water by the divers and the deployment device
  - Safe escape/drift-away route for the diving support vessel (DSV) and bell in the event of total loss of power or DP 'drive-off' where manual control is taken of the vessel
  - Where practicable diving operations should be planned to take place during weather 'off' conditions either 'blow-off' or 'drift-off' or a combination of both.

## 4 Marine Interface

### 4.1 General Principles

All DP diving support vessels should comply with this guidance and with the following:

- ◆ *Guidelines for the design and operation of dynamically positioned vessels* (Ref. 1) particularly section 1 - *Principles for all DP vessels* – and section 2 - *Diving support vessels*;
- ◆ *Guidelines for vessels with dynamic positioning system* (Ref. 4). These International Maritime Organization (IMO) guidelines apply to new vessels constructed on or after 1 July 1994 and are compatible with classification society requirements and the more definitive guidelines mentioned above.

These two documents emphasise the importance of carrying out a risk assessment and defining the time necessary to recover divers to a safe location. The equipment class of the vessel required for a particular operation (1, 2 or 3) should be agreed between the owner of the vessel and the client and should be based on a risk assessment of the consequence of losing position. Alternatively, the local administrative body or the coastal state authority may decide the equipment class for the particular operation.

The class of a vessel is noted in the flag state verification and acceptance document (FSVAD) which is contained in the IMO document (Ref. 4) and explained in IMCA guidelines (Ref. 5).

### 4.2 Isolation of Thrusters or Propellers

The feasibility of improving operational safety by deselecting or isolating relevant thrusters or propellers should be considered as part of the risk assessment. This can only be decided by the vessel master. If this is considered to be a viable procedure, the work scope should take account of the reduced capability and arrangements should be made to ensure that thruster units and/or propellers, which have been isolated or stopped, remain stopped and isolated whenever divers are in the water.

### 4.3 Resumption of Diving Activities

When diving operations have been temporarily interrupted, the DP operator must complete the appropriate checks and confirm that DP status is satisfactory before the diving supervisor orders the recommencement of diving operations.

### 4.4 Vessels in Close Proximity

When operating in close proximity, DP vessels may be subject to mutual interference including:

- ◆ thruster wash, which may affect the hull and taut wires;
- ◆ acoustic and radio interference, which may affect the position reference sensors;
- ◆ intermittent shielding from wind and waves.

These factors should be allowed for when planning such operations, for example by expecting less accurate position-keeping tolerance than normal. Co-ordination is essential to prevent interference with the vessel and the position reference.

The risk to divers from other vessels that may enter the vicinity should also be considered as part of the risk assessment.



## 5 DP Alert Responses

On a diving support vessel, DP status lights are provided for the safe conduct of diving operations and are to be used only for this purpose. On initiation of alert levels by the DP operator, diving operational responses should be carried out as defined in this section. (NB The response to the yellow alert given below has been amended from earlier guidance to provide increased flexibility while at the same time maintaining safety.)

### 5.1 Green – Normal Operational Status

Full DP diving operations can be undertaken.

### 5.2 Yellow – Degraded Operational Status

Where a yellow alert is signalled by a yellow light and an audio alarm, the audio component in dive control should be capable of cancellation.

The diving supervisor should instruct the divers to suspend operations and, where practical in terms of speed and safety, make safe any work or items of equipment that could offer a further hazard before moving to an agreed safe location<sup>1</sup>.

After consulting with the diving supervisor, the DP operator should decide on any necessary further action. This may involve the divers returning to the deployment device and preparing to return to the surface, or returning to the worksite.

If the DP operator is unable to provide clear advice, the diving supervisor should instruct the divers to return to the deployment device and/or prepare to return to the surface as appropriate.

The divers' safety is paramount. If there is any doubt about the appropriate course of action, the DP operator and diving supervisor should both act to provide the greatest protection for the divers.

### 5.3 Red – Emergency Status

The diving supervisor must instruct the divers to return immediately to the deployment device and/or prepare to return to the surface. After considering any potential hazards, e.g. fouling of adjacent anchor wires, jacket members, etc., the deployment device and/or the divers should be recovered as soon as possible.

The DP operator must use all available means to limit vessel-position loss during the recovery of the divers.

---

<sup>1</sup> A safe location is a place that affords the diver a measure of protection as agreed by the diving supervisor, the vessel master and the diver before the dive begins. This location will vary for each worksite and may, for example, involve the diver in retreating all or part of the way towards the deployment device or returning to the clump weight if a bell is used. This is an interim measure that allows the nature of the alert to be properly assessed before recalling the divers to the surface.

## 6 Vessel Movement Limitations

A diving support vessel under stable DP control may execute changes to a previously agreed position or heading without recalling the divers to the deployment device, provided all relevant personnel have been advised, and that the DP operator and the diving supervisor are both satisfied with the following criteria:

- ◆ The move can be executed safely;
- ◆ Umbilicals and other diving-related work lines (see section 7.2) are clear and will remain so during the move;
- ◆ Divers understand the move and are not endangered by it;
- ◆ Divers can easily reach the deployment device;
- ◆ Three independent position references will be online throughout the move;
- ◆ The move is executed at low speed;
- ◆ Change of heading and position are not carried out simultaneously;
- ◆ The move can be stopped at any time;
- ◆ The move will not exceed the scope of any one of the three position references;
- ◆ The move will be stopped if one position reference has to be repositioned and this results in only two position reference systems being online;
- ◆ The DP operator will verify the move input before execution;
- ◆ Due account has been taken of the selected centre of rotation when heading is to be changed.

It is recommended that the position moves and heading changes should be executed in limited steps, e.g. maximum steps of 5-10 metres and maximum heading changes of 5 degrees.

If the DP operator has any doubts about the safety of the move, he should instruct the diving supervisor to recall the divers to the deployment device and stop the move to reassess the safety of proceeding.

## 7 Umbilicals

### 7.1 Safety Principles

The safety management guidance given in section 3 should be implemented. Planning should ensure that all deployed umbilicals, i.e. those of the working diver, the bellman, and the in-water standby diver or tender (where there is one), are physically prevented from coming into contact with any hazard identified in the risk assessment during the planned scope of work. When planning umbilical lengths consideration should be given to the time taken for the divers to return to the bell.

When planning for foreseeable emergencies, suitable procedures should be drawn up, based on the particular circumstances of the diving operation, to enable the rescue/recovery of a diver in an emergency.

It should be noted that the guards sometimes provided on thrusters and propellers to prevent damage to such equipment by large items or debris are not necessarily capable of providing protection to divers or their equipment.

### 7.2 Identification of Hazards

A diagram specific to each vessel should be provided in both DP and dive control to enable the DP operator and the diving supervisor to visualise the relative position of the vessel, the deployment device and the divers in relation to the worksite, and to plan operations accordingly. This diagram should also be available in other appropriate areas. It should include:

- ◆ a thruster configuration diagram showing the deployment device at various depths, at 10 metre increments, and distance to the nearest thruster. The distance will need to be measured from the centre line of the deployment device to the outer moving part of the thruster 'envelope'. When producing the diagram, due consideration should be given to how and where the bellman's umbilical is deployed from and to where it is secured. For practical purposes, safe umbilical lengths for the working diver will be the above figure less 5 metres. (See 7.4 for more about the standby diver/bellman's requirements);
- ◆ all other hazardous areas into which umbilicals (main and excursion) must not be allowed to stray, e.g. propellers, seawater intakes, and any subsea hull obstruction that could affect the safety of diving operations;
- ◆ the position of nearby mooring lines, if appropriate (see 9.2);
- ◆ the height of subsea structures above the seabed.

In DP control, the position of ground-based reference systems and their status should also be displayed.

In dive control and, where appropriate, in ROV control, there should also be an indication of the reference systems used and the various diving-related working lines that have been deployed, e.g. deployment devices, downlines, cranes, winches, hydraulic and electric lines, taut wires and acoustic transponder locations. The supervisor should have a method for maintaining a status record of deployment devices. For the benefit of tenders operating from the deck the transverse position of thrusters should be painted on the hull above the water line and on the deck, and, if possible, on the bulwark or handrail.

### 7.3 Main Services Umbilical Safety

The main umbilical servicing the deployment device from the surface may need, in certain environmental conditions, to be secured to the bell wire at regular intervals along its length to prevent entry to the thrusters. Where this is not appropriate, the risk assessment should identify the maximum safe length of umbilical which can be deployed in relation to the depth of the bell.

A means to identify how much umbilical has been paid out is required to avoid the deployment of excess length.

## 7.4 Excursion Umbilical Safety

### 7.4.1 Umbilical Lengths

The working divers' umbilicals must be securely tended at all times during routine operations and during any foreseeable emergency intervention. Where an excursion is planned such that the diver could be brought within range of any physical hazard identified by the risk assessment (such as vessel thrusters, propellers, water intakes, etc.), that diver's umbilical must be physically restrained to prevent it from coming within five metres of such hazards.

The reach or length of the bellman / standby diver's umbilical should be two metres greater than that of the working diver's umbilical to provide manoeuvrability. At the same time it must also be restrained to prevent it coming within three metres of any identified hazard. This rule should apply whether the standby diver is located on the surface, in mid-water, or in a diving bell.

In certain circumstances, where the deployment of the standby diver and the working diver are from different locations, consideration must be taken of the proximity of hazards to these locations when calculating safe umbilical lengths. It should be noted that such considerations may impose additional restrictions on the length of the working diver's umbilical.

### 7.4.2 Additional In-Water Tender

Where an in-water tender is deployed in addition to a bellman (see 7.4.3), his umbilical must also be prevented from coming into contact with any identified hazard during a foreseeable emergency rescue (see 7.1). In addition, the risk assessment (section 3) should consider the relative functions of the bellman and the in-water tender in the event of an emergency.

### 7.4.3 Points of Tending

The tending point is defined as the surface or in-water point from which the diver's excursion umbilical can be securely tended.

Tending can be achieved safely by employing:

- ◆ a tender located on the vessel from which the working diver is deployed;
- ◆ a tender located in an additional device deployed from the DSV, either on or above the surface, such as a stage or gondola (see 7.5);
- ◆ a tender/bellman located in the deployment device from which the working diver is deployed;
- ◆ an in-water tender located mid-water or near the seabed in a separate device deployed from the vessel, in addition to the bellman (see also 7.4.2). This tending point must be able to hold position relative to the vessel if DP failure occurs;
- ◆ an unmanned in-water tending point, provided that the criteria set out in 7.7 can be met.

When the depth of the worksite puts the diver beyond physical hazards identified by the risk assessment and no restriction on umbilical length is necessary, other than consideration of bail-out capacity, then an in-water tending point may be considered to enhance the safety of a working diver who is using an extended umbilical, accessing a structure or working within a jacket structure or manifold.

Where the standby diver is located on the vessel and he is deployed in the water in an additional device, procedures should be in place to maintain his umbilical to prevent it from coming within three metres of the nearest hazard.

## **7.5 Deployment of the Excursion Umbilical**

The length of umbilical deployed should be kept to a minimum to prevent it becoming snagged and to permit easier recovery of a diver in an emergency, particularly when currents are present. At the same time, allowance should be made for vessel movement within the DP footprint.

In order that the length of umbilical deployed can be monitored, the umbilical should be marked at appropriate intervals.

In certain circumstances, a diver may secure himself underwater in order to achieve stability. In such cases, a recommended 'weak link' should be used. The means by which the diver's umbilical is prevented from coming into contact with a hazard should not be dependent on this weak link.

The working diver, tender and bellman should each monitor the marking and relative position of the umbilical, and immediately inform the supervisor of any concern regarding its safety.

In some surface supplied diving operations, the diver's point of entry may be some way from the deck (either in terms of distance or elevation). In such cases, it may be appropriate, subject to suitable risk assessment (see section 3), to position a tender at an intermediate point on or above the waterline by means of a basket, light craft or other appropriate means. If this form of intermediate tendering is employed, the device containing the tender should be monitored and effective communications maintained.

## **7.6 Use of Negatively Buoyant Umbilicals**

The use of negatively buoyant umbilicals may provide an inherently safer operation in some circumstances.

## **7.7 Deployment of Divers Using In-Water Tending Points**

When access to certain work sites is restricted it may be necessary to deploy a diver/divers beyond the pre-determined safe umbilical length as determined from the distance between the deployment device and the nearest hazard, e.g. thruster.

Typical restrictions may be platform overhangs, flare towers, lifeboats, bridges and such like.

Access can be safely achieved using active and passive diver tending. This can be carried out in either saturation or air diving mode and utilises a device (basket or similar) suspended from the cherry picker, crane or working platform on the vessel. It is preferred but not essential that the basket be deployed on a man riding lifting device.

Tending with active and passive methods utilises different operating techniques as set out below.

A diver access study will determine the length of umbilical required and contribute to the assessment process to decide which method of umbilical management should be used.

This document details two preferences that may be considered:

- i) Active tending, where the task or diving conditions warrants enhanced umbilical management;
- ii) Passive tending, where there is a requirement to utilise one or two divers at the worksite.

Tending can be achieved using active or passive tending provided the following criteria are met.

### 7.7.1 Active Tending at the (Manned) In-Water Tending Point

Active tending at the in-water tending point enables enhanced umbilical management in situations similar to those described above.

Where the planned excursion using active tending at the in-water tending point is undertaken the following criteria are to be met. In the event of the tender becoming incapacitated, the working diver should have available to him sufficient length of umbilical to allow his direct return to the deployment device without the disconnection of his umbilical from the swim line. This is addressed by ensuring that at all times his maximum allowable excursion beyond the in-water tending point meets the greater than 'B' requirement shown in Figure 1.

- ◆ The tending point is held in position relative to the vessel;
- ◆ The length of the working diver's umbilical must be restrained in such a way that it cannot reach to within five metres of any physical hazards (such as thrusters, propellers etc.);
- ◆ The reach of the in-water tender and bellman/standby diver umbilicals' is restrained such that each is two metres longer than that of the working diver's umbilical, to provide manoeuvrability but cannot reach to within three metres of any physical hazard;
- ◆ Where the working diver and standby diver are deployed from different locations, this should be taken into account when calculating safe umbilical lengths;
- ◆ A swim line is fixed between the deployment device and the manned in-water tending point;
- ◆ The working diver's umbilical is secured to the swim line between the deployment device and the manned in-water tending point at the maximum allowable excursion distance from the in-water tending point;
- ◆ The bellman's/in-water tender's umbilical and that of any standby diver is secured to the swim line between the deployment device and the manned in-water tending point at the calculated maximum excursion distance for the working diver from the in-water tend point plus two metres;
- ◆ A task-specific risk assessment is carried out and, where appropriate, additional measures identified are provided;
- ◆ Suitable procedures should be in place, based on the particular circumstances of the diving operation, to permit recovery of a diver in an emergency;
- ◆ Consideration should also be given to the safe recovery of the diver to the surface.

*For active (manned) in-water tending the following constraints apply to the safe working distance for the working diver's umbilical:*

$$C_{\max} = D - 5 \text{ metres}$$

**OR**

$$C_{\max} = A - 5 \text{ metres, depending which distance is shorter}$$

**AND**

B is always less than C

(This is to allow, in the event of an emergency, direct recovery of the diver to the deployment device.)

where:

A = distance from the deployment device to the nearest physical hazard

B = distance from the deployment device to the in-water tending point

C = distance from the in-water tending point to the diver

D = distance from the in-water tending point to the nearest physical hazard

See Figure 1.

### 7.7.2 Passive Tending at the (Unmanned) In-Water Tending Point

Passive tending at the in-water tending point, utilising one or two working divers at the worksite, can be carried out provided the following criteria are met:

- ◆ The tending point is held in position relative to the vessel;
- ◆ The length of any working diver's umbilical must be restrained in such a way that it cannot reach to within five metres of any physical hazards (such as thrusters, propellers etc.);
- ◆ The reach of the bellman/standby diver's umbilical is restrained such that it is 2 metres longer than that of the working diver's umbilical to provide manoeuvrability but cannot reach to within three metres of any physical hazard;
- ◆ Where the working diver(s) and standby diver are deployed from different locations, this should be taken into account when calculating safe umbilical lengths;
- ◆ A swim line is fixed between the deployment device and the unmanned in-water tending point;
- ◆ An appropriate method or procedure must be in place to ensure that any working diver's umbilical is restrained at its maximum allowable excursion distance at the unmanned in-water tending point;
- ◆ The bellman's umbilical and that of any standby diver is secured to the swim line between the deployment device and the unmanned in-water tending point at the calculated maximum excursion distance for the diver from the in-water tending point plus two metres;
- ◆ A task specific risk assessment is carried out and, where appropriate, additional measures identified are provided;
- ◆ If a problem begins to arise when two divers are on passive tending, then one diver should return to the tend point and revert to active tending;
- ◆ Suitable procedures should be in place, based on the particular circumstances of the diving operation, to permit recovery of a diver in an emergency;
- ◆ Consideration should also be given to the safe recovery of the diver to the surface.

*For passive (unmanned) tending the following constraints apply to the safe working distance for the working diver's umbilical:*

$$C_{\max} = D - 5 \text{ metres}$$

**OR**

$$C_{\max} = A - 5 \text{ metres, depending which distance is shorter}$$

**AND**

B is always less than C

(This is to allow, in the event of an emergency, direct recovery of the diver to the deployment device.)

Where:

A = distance from the deployment device to the nearest physical hazard

B = distance from the deployment device to the in-water tending point

C = distance from the in-water tending point to the diver

D = distance from the in-water tending point to the nearest physical hazard

See Figure 1.

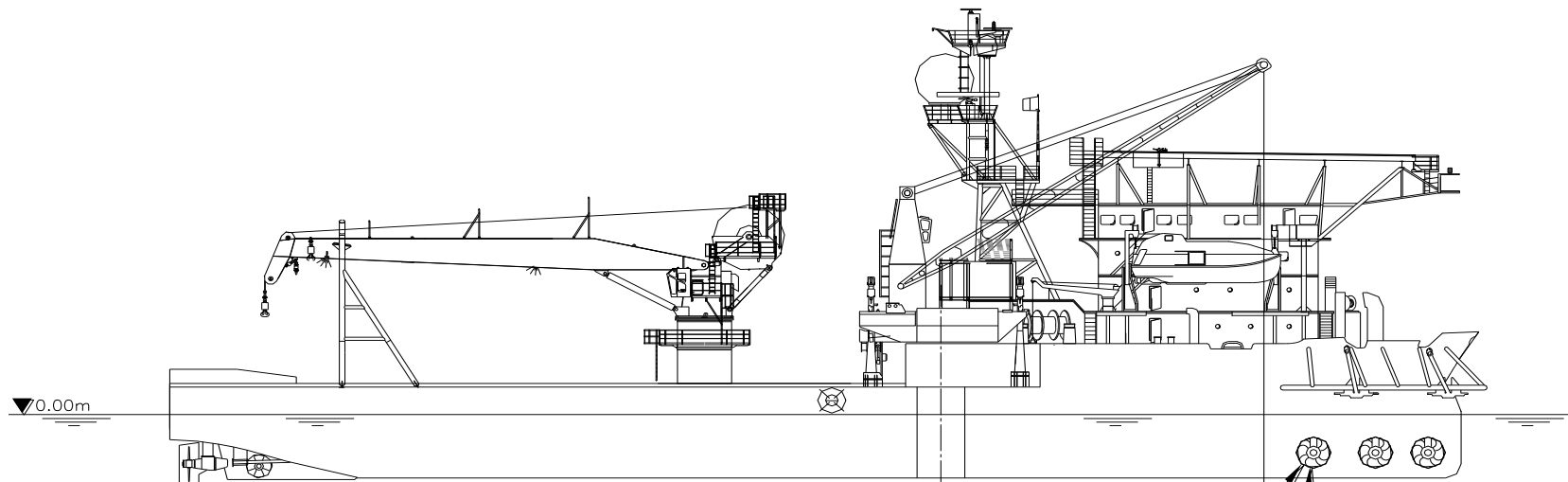

$C_{max} = D - 5 \text{ metres}$

OR

$C_{max} = A - 5 \text{ metres}$

and B is always less than C

where:

A = distance from the deployment device to the nearest physical hazard

B = distance from the deployment device to the in-water tending point

C = distance from the in-water tending point to the diver

D = distance from the in-water tending point to the nearest physical hazard

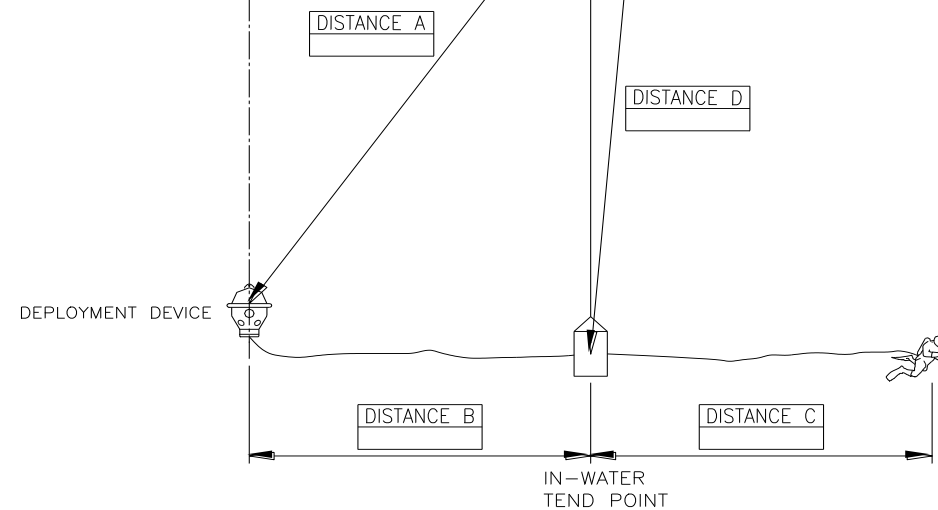

**Figure 1**

IMCA D 010 Rev. 3



## 8 Shallow Water

### 8.1 Limitations

In relation to vessel safety, the only limit on a DP vessel in shallow water is draught, assuming that the requirements regarding vessel capability and position reference are fulfilled (see sections 8.2 and 8.3). The safety of the divers can be affected by other factors, however. For example, the proximity of thrusters may endanger their umbilicals, or the flow of water to and from the thrusters, which will vary with depth, may affect visibility. These factors will need to be addressed by evaluation, planning and risk assessment (see section 3).

### 8.2 Vessel Draught

The master of the DP vessel should determine the appropriate clearance the vessel needs between the seabed and the keel or lowest thruster taking into account the weather forecast, heights of the tides, vessel motion and the presence of subsea obstructions. Consideration should also be given to the clearance that is required by the divers' deployment device. The above factors will determine the shallow water limits of a DP DSV.

Where water depth that limits the direction of escape is close by, care should be exercised to monitor the tide and determine the safe routes to deeper water.

### 8.3 Vessel Capability

The vessel's capability plots may not accurately give the limiting environmental conditions for shallow water and operators should expect higher thruster and generator loads than for the same wind speed in deeper water and, as a consequence, termination of diving support operations earlier than might otherwise have been expected.

For vessels with a consequence analysis warning, the reduced capability should automatically be taken into account.

### 8.4 Position References

The major difference between deep and shallow water diving support operations is the distance the vessel is able to move whilst maintaining seabed based position references on line. This is further reduced if the accuracy of the position references is poor. Each of the vessel's position references should provide position information accurate to  $\pm 2\%$  of the water depth. For example in 30m of water the information provided by the reference systems should have a standard deviation of  $\pm 0.6\text{m}$ .

There should always be at least three position reference systems on line of which one should be a radio or surface position reference. When working in water depths of less than 60m the scope (radius of operation) of each of the three position references should be equal to or greater than 30% of the water depth, and never less than 5m for example water depth =30m, radius of operation 9m.

In general terms, the shallower the water depth the smaller the scope for movement before seabed position reference sensors need relocation. In particular:

- ◆ the scope of vertical taut wires is greatly reduced depending on the height of the suspension point;
- ◆ acoustics are more susceptible to interference from the vessel;
- ◆ the peak natural excursion of the vessel can exceed the scope of a bottom position reference.

Surface reference systems, not being susceptible to water depth, may offer greater reliability. These may, however, have limitations, the acceptability of which should be assessed, for example the Artemis range may be too great for accurate bearing resolution. The standard deviation of the vessel's natural excursions should not exceed one third of the scope of any position reference.

For more information see section 2.5 of Ref. 1.

## **8.5 Environmental Conditions**

Diving operations in shallow water are more sensitive to weather than those in deeper water and this should be considered when planning such operations. For example, shallow waters are often associated with strong, rapidly changing currents that can affect operations.

Any reduction in water visibility due to tidal current or the proximity of the thrusters, combined with the effect of these currents on the diver's body, may affect the diver's ability to operate efficiently without interfering with such items as taut wires, etc.

The closeness of the vessel may also cause vessel noise to affect diving communications.

## **9 Diving Within an Anchor Pattern**

### **9.1 Safety Principles**

Diving within an anchor pattern restricts the movement of the vessel and may introduce additional hazards. Special consideration should be given to emergency and contingency procedures during the evaluation, planning and risk assessment of this type of operation (see section 3).

The primary hazard to be considered when performing manned intervention from a DSV within an anchor pattern is that in the event of a DP failure or 'black ship' incident, when in the 'blow-on'/'drift-on' position, the DSV could drift across the mooring catenary.

The environmental forces should be considered and the direction and rate of vessel drift taken into account, along with the distance to the anchor line and the time taken to recover the bell to a position above the catenary. It may be necessary to conduct drift trials and diver recovery trials in order to determine whether the vessel would drift onto the anchor line before recovery of the bell is possible. The risks identified during these trials should be used to determine if diving can safely proceed.

### **9.2 Mooring Line Identification**

When supporting divers from a position inside the mooring pattern of another vessel, drill rig or offshore installation, it is essential that anchor positions are confirmed by the other vessel, drill rig or installation and the position of the mooring lines by two independent means, one of which may be by calculation.

If a vessel returns to the same location, it is necessary to recheck these positions.

### **9.3 Mooring Line Adjustments**

If the risk assessment (see section 3) has indicated that a mooring line can be safely lowered to the seabed, it is still necessary for the position of the line to be identified, for example, by verifying that the tension has been lowered at the installation, or by ROV inspection, etc.

The other vessel, rig or installation must not move or adjust mooring line tension or position during the diving operation. If necessary, the OIM should inform the vessel master of any environmental changes or proposed draught changes that will affect the catenaries of mooring lines. This should invoke management of change procedures.

The DSV DP operator must be able to monitor the other vessel, rig or installation from which the mooring lines are deployed at all times, either with radar or by radio. Diving operations should be stopped immediately if communications to the installation are lost.

### **9.4 Permit-to-Work and Reporting Procedures**

A reporting procedure should be established between the vessel master and the OIM to provide relevant information, such as the operation of other vessels in the area. There should also be an interface between the permit-to-dive procedure on the vessel and the permit-to-work system on the other vessel, rig or installation concerning mooring line adjustment or any other activity that might adversely affect the diving operation.

### **9.5 Minimum Operating Clearance**

A horizontal clearance of at least 50 m should normally be maintained between a suspended mooring line and a deployed bell or basket. This nominal distance of 50 m in a 'blow-on'/'drift-on' situation would, in most circumstances, be inappropriate. The appropriate minimum operating clearance should, in such cases, be determined from the outcome of a risk assessment which may include a drift trial.

If the DSV master, the OIM, the diving superintendent, the diving supervisor and the client agree that a clearance of less than 50 m is essential for executing the work, the following should be adhered to:

- ◆ The position of the mooring line should be plotted, and remain traceable throughout the operation. This can be achieved with an ROV-mounted transponder or other suitable means;
- ◆ The time spent with the bell in water with a clearance of less than 50 m should be minimised;
- ◆ Twin bell systems should not to be deployed simultaneously within the anchor pattern;
- ◆ Emergency provision for the loss of the bell needs to be considered during the evaluation, planning and risk assessment (see section 3).

Movement at the touch-down point of the mooring line is inevitable and unpredictable, and can result in poor seabed visibility and entrapment of a diver and/or his umbilical. This should be addressed during the evaluation, planning and risk assessment (see section 3).

## **9.6 Position References**

Care should be taken to prevent vessel position reference taut wires from coming into contact with the mooring lines because this will result in the loss of the seabed position reference. If it is technically feasible, a radio or surface position reference should always be used.

## **9.7 Operational Plots**

The thruster configuration diagram (see section 7.2) should include the position of mooring lines in an easy-to-assimilate form. The vessel should also have onboard diagrams showing the catenaries and touch-down points for various mooring-line tensions.

## 10 Subsea Structures and Wellheads

Diving within the vicinity of pipelines is the subject of separate guidance (Ref. 7). Separate IMCA guidance is also available on diving on subsea structures (Ref. 8).

When a DP vessel is close to a fixed underwater structure or obstruction which is totally or almost totally submerged (e.g. a mid-water arch dynamic riser), diving from a deployment device is potentially hazardous because there are few, if any, visual references on the surface. Special consideration should be given to emergency and contingency procedures for such operations during the evaluation, planning and risk assessment (see section 3). Consideration should also be given to presence of debris either attached to or in the vicinity of the subsea structure.

The structure's location and depth should be recorded in the operational plot (see section 9.7) and consideration given to providing a reference point to verify its location, e.g. ROV or marker buoys.

Subsea wellheads are frequently enclosed by a protective structure with provision for diver access/egress. Alternatively the wellhead may be partially enclosed by a substantial bumper framework. Accessing such structures can be hazardous for divers, and the following guidance should be employed.

- ◆ The location and depth of the deployment device and clumpweight arrangement in relation to the subsea structure should be determined following evaluation, planning and risk assessment (see section 3) and should take account of: environmental conditions, the height of the structure, the diver's entry point, the vessel footprint, available position reference systems, and the diver's upward and downward excursion limits;
- ◆ Sufficient umbilical should be reserved in the deployment device to allow for minor vessel movement. A diver making an excursion into a totally enclosed structure should be tended at the entry point by a second diver (see section 7.4.3);
- ◆ The position of the vessel and the deployment device will be governed by a number of factors however both should be protected from any hazards identified in the risk assessment. For example, if leakage of hydrocarbons or other noxious substances is possible, the deployment device should be positioned to the side of the structure to prevent the prevailing current carrying any such substances into the deployment device. Consideration should also be given to ways of minimising or preventing such substances from affecting the divers or impeding their abilities.

## II References

- Ref. 1 *Guidelines for the design and operation of dynamically positioned vessels*, IMCA M 103 Rev. 1 (2007)
- Ref. 2 *The training and experience of key DP personnel*, IMCA M 117 Rev. 1 (2006)
- Ref. 3 *ROV intervention during diving operations*, AODC 032 Rev. 1 (1992)
- Ref. 4 *Guidelines for vessels with dynamic positioning systems*, International Maritime Organization (IMO) MSC Circular 645 (1994) (available from IMCA as I 13 IMO)
- Ref. 5 *Guidelines to the issue of a flag state verification and acceptance document*, I27 DPVOA (1995)
- Ref. 6 *Diver attachment to structures by means of a weak link*, AODC 058 (1993)
- Ref. 7 *Guidance on diving operations in the vicinity of pipelines*, IMCA D 006 Rev. 2 (1999)
- Ref. 8 *Guidance on diving operations in support of intervention on wellheads and subsea facilities*, IMCA D 019 (1999)