

## **DIVISION 22 – PLUMBING**

---

### **FORMAT**

1. Technical specifications content and numbering system shall be based on 2004 version of CSI MasterFormat.

### **BASIS OF DESIGN**

1. BGSU Design standards shall not replace fully developed, project and market specific technical specification. Architect/Engineer (A/E) shall utilize the Standards as a minimum standard to guide the design and execution in the field. **Exceptions to these standards are allowed provided they are approved by Design & Construction.**
2. In instances where fewer than 3 manufacturers are indicated in the Mechanical Preferred Manufacturer's List, the A/E shall insert "or approved equal" in the Products section of the technical specifications.
3. All submitted substitute products shall be brought to the attention of Design & Construction, prior to approval. Provide fully functional samples upon request.
4. New technology will be considered by BGSU for plumbing installations.

### **RELATED SECTION**

23—MECHANICAL

26—ELECTRICAL

Appendix B - ENERGY CONSERVATION

Appendix D - INFRASTRUCTURE

### **GENERAL PROVISIONS**

1. Access Panels
  - a. Provide access panels for valves, clean outs, equipment, etc., installed above an inaccessible ceiling such as plaster or concealed spline.
2. Plumbing Identification
  - a. Provide labels to identify all control panels, disconnects, motor control centers as well as equipment served.
  - b. All piping shall be identified by stencil or label indicating service and direction of flow. As referenced by OSHA, labeling shall comply with ANSI A13.1 standard.
3. Housekeeping Pads
  - a. All floor mounted equipment shall be set on 4" housekeeping concrete pads.
4. Support & Anchors
  - a. Piping
    - i. Attached to structural members by beam clamps bearing on both sides. Do not weld.
    - ii. When attaching to bar joists, attach at the panel points only.
    - iii. Attach to concrete decking using expansion bolts or concrete anchors.
    - iv. Wrought iron clevis type, Grinnell No. 260.
    - v. Copper-plated plastic-coated hangers, Grinnell Fig. CT-99C.

- vi. Insulated pipe provide oversized hangers to fit on the outside of the pipe saddles and shields.

## **220523 – GENERAL DUTY VALVES FOR PLUMBING**

### 1. Valve Boxes

- a. A concrete collar is to be installed around new and existing valve boxes in all non-paved areas (such as turf, gravel, pavers, etc.) except when valve box is located fully in a concrete surface. Collars shall be designed to the figure below.

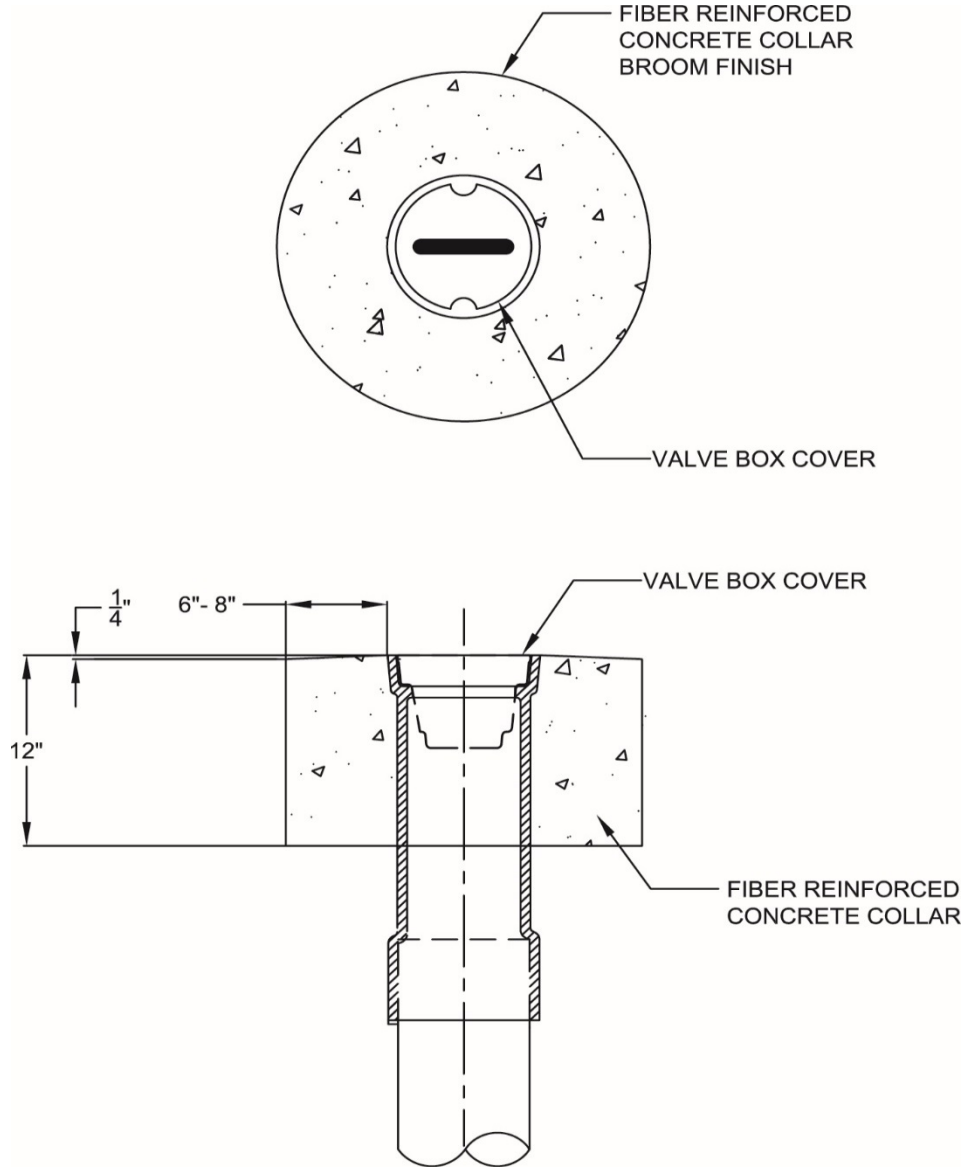

**STANDARD FOR CONCRETE  
COLLAR FOR VALVE BOX IN  
NON PAVEMENT SURFACES**

N.T.S.

- b. A concrete collar is to be installed around new and existing valve boxes in all asphalt surfaces. Collars shall be designed to the figure below.

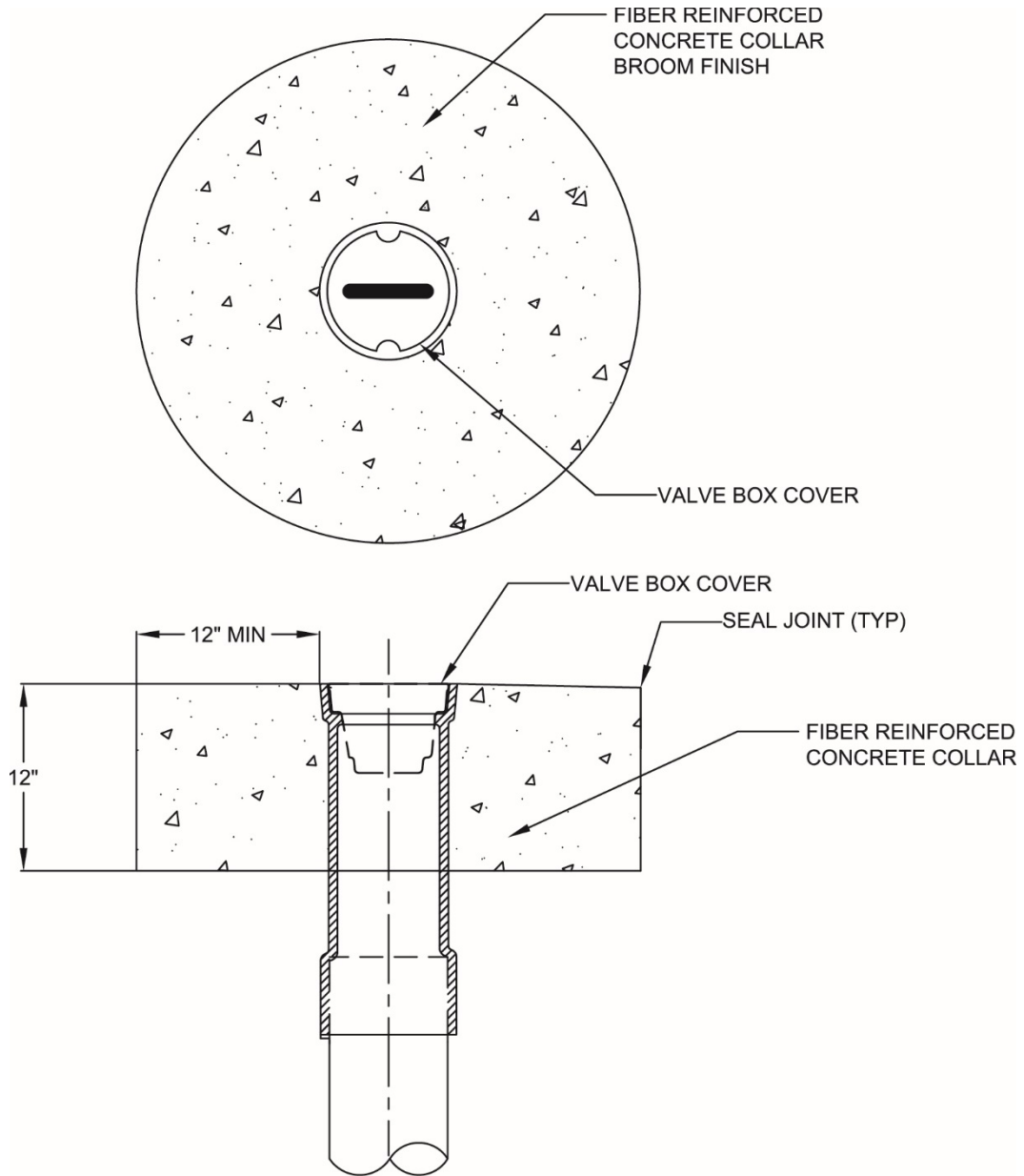

**STANDARD FOR CONCRETE  
COLLAR FOR VALVE BOXES IN  
ASPHALT**

N.T.S.

**220719 – PLUMBING PIPING INSULATION**

1. Composite assembly shall have a flame spread rating not over 25 and a smoke developed rating not higher than 50.
2. Piping Insulation – Above Ground, Mineral Fiber or Cellular Glass. All service jacket with self-sealing lap adhesive. Thermal conductivity (k) shall not exceed 0.24 BTUH square foot F°/inch.
3. Pipe fittings shall be covered with insulating cement or preformed insulating fitting cover. All exposed piping insulation shall be covered with a PVC jacket.
4. Handicap lavatories with exposed P-trap, hot and cold water angle stops and supplies shall be insulated.
5. Buried or under floor services shall be avoided wherever possible. When not avoidable, these services shall be coordinated with other trades and dimensionally located and noted so other service shall be installed over such services.
6. Insulate the piping to minimum requirements of current ASHRAE 90.1 standard.

## 221005 – PLUMBING PIPING

### 1. Schedule of Piping

SERVICE	PIPE SIZE	MINIMUM WORKING PRESSURE & TEMPERATURE	MATERIALS	JOINT	FITTINGS	UNIONS / FLANGES / COUPLINGS	GASKETS	MANUAL ISOLATION VALVES	EXPANSION
Indoor, Aboveground Domestic Cold & Hot Water	2 1/2 inch and smaller	150 psig 200F	Copper ASTM AB88 Type L  PEX piping will be considered for use upon approval by BGSU	Solder ASTM B 32, lead-free alloys. with water-flushable flux per ASTM B 81 3 or Pressfit type system pressure seal with EPDM-rubber O-ring seal in each end	Wrought-Copper Fittings: ASME B16.22. Or Pressfit type system	Wrought-Copper Unions: ASME B16.22. Or Pressfit type system	-----	<b>2 inch and smaller</b> - Ball, Full port, two piece, bronze body, stainless steel stem, PTFE or TFE seats, stainless steel vented ball. MSS SP-110. Screwed joint ends. <b>2 1/2 inch and larger</b> – Ball as noted above or Butterfly type flanged with cast iron body, and EDPM liner	Bronze hoses and single-braid bronze sheaths with 450 psig at 70 deg F and 340 psig at 450 deg F ratings. Copper-alloy fittings with solder-joint end connections.
	3 inch and larger	150 psig 200 F	Schedule 40 ASTM A 312/A 312 M	Mechanical	SS ASTM A 815/A815 M	Mechanical Couplings for grooved end	EPDM-rubber gaskets suitable for hot and cold water		
Indoor, Aboveground Natural Gas	2 inch and smaller	150 psig 200F	Schedule 40, Carbon Steel, ASTM A 53, Type E or S, Grade B	Screwed	Malleable-Iron, ASME B16.3, Class 150, standard pattern.	ASME B16.39, Class 150, malleable iron with brass-to-iron seat, ground joint	----	Ball, Full port, two piece, 175 CWP, bronze body, bronze blowout proof stem, reinforced PTFE blowout proof seats, chrome plated ball. MSS SP-110, ASTM B584, Threaded ends.	-----
	2 1/2 inch and larger	150 psig 200F	Schedule 40 Carbon Steel ASTM A53 Grade B ERW	Butt Welded ANSI/AWS D1.1	ASTM A234, forged steel Class 150	Class 300 steam forged steel slip-on flanges or weld – neck flanges for carbon steel	Spiral wind style, 316L metal winding strip, with flexible graphite filler and Stainless Steel 316L centering ring gaskets.	Cast Iron nonlubricated plug valve, 200 psig WOG, cast iron body, bronze or nickel plated cast iron plug, thermoplastic coated seat, square head or lug type operator with tamperproof feature where indicated, flanged ends.	-----

Schedule of Piping (continued)

SERVICE	PIPE SIZE	MINIMUM WORKING PRESSURE & TEMPERATURE	MATERIALS	JOINT	FITTINGS	UNIONS / FLANGES / COUPLINGS	GASKETS	MANUAL ISOLATION VALVES	EXPANSION
Indoor, Aboveground Compressed Air (150 psig)	2 inch and smaller	150 psig 200F	Schedule 80 Carbon Steel ASTM A53 Grade B ERW	Screwed	ANSI/ASTM B16.3, malleable iron Class 150	ANSI/ASTM B16.3, malleable iron Class 150	----	Ball, Full port, two piece, 600 CWP, bronze body , stainless steel stem, PTFE or TFE seats, stainless steel vented ball. MSS SP-110. Threaded ends.	----
	2 1/2 inch and larger	150 psig 200F	Schedule 40 Carbon Steel ASTM A53 Grade B ERW	Butt Welded ANSI/AWS D1.1	ASTM A234, forged steel Class 150	Class 300 steam forged steel slip-on flanges or weld – neck flanges for carbon steel	Spiral wind style, 316L metal winding strip, with flexible graphite filler and Stainless Steel 316L centering ring gaskets.	Ball, Full port, two piece, 600 CWP, bronze body, stainless steel stem, PTFE or TFE seats, stainless steel vented ball. MSS SP-110. Threaded ends.	----
Indoor Aboveground Vacuum Piping	2 inch and smaller	150 psig 200F	Schedule 80 Carbon Steel ASTM A53 Grade B ERW	Screwed	ANSI/ASTM B16.3, malleable iron Class 150	ANSI/ASTM B16.3, malleable iron Class 150	----	Ball, Full port, two piece, 600 CWP, bronze body , stainless steel stem, PTFE or TFE seats, stainless steel vented ball. MSS SP-110. Threaded ends.	----
	2 1/2 inch and larger	150 psig 200F	Schedule 80 Carbon Steel ASTM A53 Grade B ERW	Butt Welded ANSI/AWS D1.1	ASTM A234, forged steel Class 150	Class 300 steam forged steel slip-on flanges or weld – neck flanges for carbon steel	Spiral wind style, 316L metal winding strip, with flexible graphite filler and Stainless Steel 316L centering ring gaskets.	Ball, Full port, two piece, 600 CWP, bronze body , stainless steel stem, PTFE or TFE seats, stainless steel vented ball. MSS SP-110. Threaded ends.	----

Schedule of Piping (continued)

SERVICE	PIPE SIZE	MINIMUM WORKING PRESSURE & TEMPERATURE	MATERIALS	JOINT	FITTINGS	UNIONS / FLANGES / COUPLINGS	GASKETS	MANUAL ISOLATION VALVES	EXPANSION
Underground, Domestic Water	All Sizes	150 psig 200F	PVC AWWA C900	Bell End & Spigot	Ductile Iron Push-On Fittings	Ductile Iron Push-On Fittings	-----	Gate, AWWA C509, OS&Y rising stem, metal seated. Coating per AWWA C550. Gray or ductile-iron body and bonnet; with bronze, gray or ductile-iron gate, resilient seats, bronze stem, and stem nut	-----
		150 psig 200F	HDPE SDR11	Butt Fused	HDPE SDR11	HDPE SDR11	-----		-----
Underground Natural Gas	All Sizes	150 psig 200F	Polyethylene, ASTM D2513 SDR11	Socket Fused or But Weld	Polyethylene, ASTM D2683 or ASTM 3261	Polyethylene, ASTM D2683 or ASTM 3261	----	Ball with polyethylene body and ball, 80 CWP, Nitrile Stems and Seats Acetal Stem.	-----



## Schedule of Piping (Continued)

SERVICE	CONDITIONS	MATERIALS
Sanitary Waste	Exterior of Building Underground $\leq 15'' \varnothing$	PVC ASTM D-3034 SDR 35
	Inside Building Underground $\leq 15'' \varnothing$	Hubless ASTM A888 or CISPI 301 cast-iron soil pipe and fittings
		PVC Schedule 40 DWV ASTM D-2665. Specify only where elevated waste water temperatures are not a concern. See notes below.
Sanitary Waste & Vent	Inside Building Aboveground $\leq 15'' \varnothing$	Hubless ASTM A888 or CISPI 301 cast-iron soil pipe and fittings
Storm	Exterior of Building Underground $\leq 15'' \varnothing$	PVC ASTM D-3034 SDR 35
	Inside Building Underground $\leq 15'' \varnothing$	
		PVC Schedule 40 DWV ASTM D-2665
	Inside Building Aboveground	Hubless ASTM A888 or CISPI 301 cast-iron soil pipe and fittings

## 2. Sanitary.

- a. Fill material around piping below slab shall be compacted granular material to 95 percent-modified proctor.
- b. Piping shall not be installed parallel/directly under walls. Minimum parallel distance from a wall to the pipe shall be 3 feet for repair access.
- c. Piping above grade shall be Schedule 40 polyvinyl chloride or cast iron, no hub with approved hanger spacing.
- d. Piping in a plenum shall be cast iron, no hub. Schedule 40 polyvinyl chloride is not approved for use in a plenum space.
- e. Sanitary Piping – Avoid the use of cross tees for all branch line. Y fittings are preferred for cleanout purposes. No tees in lavatory drain piping. Piping in multistory buildings must be cast iron. Piping in and downstream of Kitchens and Mechanical Rooms must be cast iron and all PVC connections to this line must include 3'-0" of cast iron at the connection fitting. No hub bands on cast iron pipe shall be equal to Husky "heavy duty," type 304 stainless steel, 4 clamping bands type.

- f. Cleanouts in sanitary systems shall be located outside the toilet chase if accessible or in chase walls if there is not access. They shall be located above the flood level rim of the highest water closet (minimum 10 inches) but no more than 24 inches above the finished floor. Cleanouts located in the wall shall be a no-hub cap with stainless steel band connection. Tap no-hub cap for fastening over size stainless steel wall plate cleanout cover. Plate access hole must be made large enough to remove no-hub bands and cap for cleaning out sanitary piping. Cleanouts shall not be located in main communication areas.
  - g. Vent Piping – PVC is acceptable in non-plenum areas.
  - h. Vent System – Air admittance valves are to be avoided if possible, but are acceptable where conventional venting is not possible. Follow all requirements as dictated by The State of Ohio Plumbing Code.
  - i. Provide information to the Site Design Professional as to the depth of the sewer(s) exiting the building.
  - j. Provide information to the Structural Design Professional as to the location and depths of the sewer in relationship to footings and columns as they pertain to the project.
3. Acid Waste.
- a. Acid waste piping below grade shall be Schedule 40 polypropylene with fusion joints. All acid waste piping above grade shall be Schedule 40 polypropylene with mechanical joints. Acid waste piping in a plenum shall be fire and smoke-rated polyvinylidene fluoride or glass.
  - b. Acid neutralizing sumps shall be located on the exterior of the building with access to grade.
4. Roof Drain / Storm.
- a. Piping materials shall include Schedule 40 polyvinyl chloride with solvent joints or cast iron no hub.
  - b. Fill material around piping below slab shall be compacted granular material to 95 percent-modified proctor. Piping shall not be installed parallel/directly under walls. Minimum parallel distance from a wall to the pipe shall be 3 feet for repair access.
  - c. Piping above grade shall be Schedule 40 polyvinyl chloride or cast iron, no hub, with approved hanger spacing. Piping above plenum shall be cast iron, no hub. Schedule 40 polyvinyl chloride is not approved for use in a plenum space.
  - d. Provide connections to all roof drains.
  - e. Provide information to the Site Design Professional as to the depth of the sewer(s) exiting the building.
  - f. Provide information to the Structural Design Professional as to the location and depths of the sewer in relationship to footing and column pass as they pertain to the project.
5. Natural Gas.
- a. Gas piping in plenums shall not contain valves or unions.
  - b. Provide a valve and a dirt leg at each appliance connection.

- c. Natural gas piping to island sinks shall be in an accessible trench in the floor with a removable cover.
6. Potable Water.
- a. All domestic water entering the building must pass through a reduced pressure backflow preventer to protect the outside water source from contamination in the building. A main pressure-reducing valve is required if the incoming water pressure exceeds 80 psi.
  - b. Water distribution throughout the facility will be through piping systems located above ceiling areas. Piping installed under slab areas will not be permitted, unless accessible for maintenance on the system.
  - c. Domestic water systems within the building shall be copper tubing. The use of polyvinyl chloride, chlorinated polyvinyl chloride, or polybutylene material will not be permitted.
  - d. The required pressure for operation of the furthest fixture from the incoming service will determine if a pressure booster system will be required.
  - e. The booster system should be a packaged unit that includes all controls. Provide a constant-speed duplex pump package with bladder-type compression tank to meet the flow requirements. It will be necessary to consider the installation of an emergency power system in order to maintain the operation of the booster system in the event of power outages, if the building is to be used during emergency-type occupancies. Coordination with the Electrical Design Professional will be necessary.
  - f. Minimum pressure required at the furthest fixture connection shall be 30 psi.
  - g. The minimum pipe size for potable water piping shall be  $\frac{3}{4}$ -inch.
7. Valves
- a. All valves shall be of one manufacturer for each type of valve.
  - b. Isolation valves shall be installed on all equipment.
  - c. Isolation valves shall be installed on all piping risers inside buildings.
  - d. Isolation valves shall be installed on supply and return piping at all equipment for isolation and/or removal and also at all sinks in Residence Halls.
  - e. Isolation valves will be installed to isolate individual plumbing fixtures and groups of plumbing fixtures to permit shut down of the fixture or equipment item without affecting the remainder of the building. Isolation valves shall be provided at each floor in an accessible chase.
  - f. The domestic water system valves shall be bronze construction with a ball-type conventional port or cast iron butterfly valve per piping schedule.
  - g. All domestic water valves shall be full port ball type on  $2\frac{1}{2}$  and smaller.

## **221006 - PLUMBING SPECIALTIES**

### **1. Floor Drain - FD**

- a. Floor drains shall be installed in each large group restroom, locker room, mechanical room, and kitchen area. Provide a sediment bucket in the floor drain if conditions exist where solids may enter the drain only. Sediment buckets are

- not to be specified for most applications other than special applications where required.
- b. Trap primers will be required where the water in a floor drain could dry up in the trap seal and permit sewer gases into the building. Trap primers shall be accessible for repair.
  - c. All floor drain outlets - non shower drain, shall be a minimum of 3-inch.
2. Roof Drain – RD
    - a. Cast iron body, receiver, extension for roof insulation, underdeck clamp and ply cone.
  3. Wall Hydrant – WH
    - a. Outside wall hydrants, shall be loose key wall type, freezeproof, with vacuum breaker.
    - b. Provide at intervals not to exceed 75 feet between hydrants.
  4. Sanitary and storm sewer cleanouts shall be installed at 50 feet on center and at changes in direction of 90 degrees or more, at the bottom of vertical risers and as the sewer exits the building.
  5. Install a cold/hot water stainless steel hose box in each large group restroom/shower room. The hose box shall be recessed in wall with integral key lockable door. Hose box shall be equal to Acorn type.
  6. Reduced pressure backflow preventers are required on the water supplies to each HVAC makeup water system.
  7. A water pressure reducing station requiring 2 pressure reducing valves sized for 1/3 and 2/3 flow shall maintain the water pressure in the building to a maximum of 80 psi, if the incoming water pressure can exceed 80 psi.
  8. Relief valves shall be piped to discharge in a floor drain with funnel, with only one elbow. If more than one elbow is required, a union shall be installed close to the valve to facilitate easy replacement. In no cases shall there be more than three elbows from valve to point of discharge.
  9. Water hammer arresters shall be installed at all major fixture groupings and wherever there is a potential for water hammer. Water hammer arrestors shall be installed in an accessible location or accessible via access panel where required.
  10. Drain valves shall be installed at all low points in the system to facilitate drainage and shall incorporate threaded hose adapter with chained end cap.

**223000 – PLUMBING EQUIPMENT**

1. Simplex Clear Water Lift Station
  - a. Pump to be complete with built-in capacitor and starting switch, #303 Stainless Steel shaft, ball bearings, mechanical seal and strainer.
  - b. NEMA alarm panel including cable, float, alarm light and alarm horn with silencing switch. A separate 115 volt power source shall be furnished for this alarm panel.
  - c. Control system with control box, two float switches with cable and a heavy duty contactor.
  - d. Clear water sump shall be cast iron with tapped flanged or precast reinforced concrete or high strength plastic fiberglass reinforced.
  - e. Pump shall be screenless non-clog submersible sewage lift pump. NEMA 6 air filled submersible type having cast iron shell with special fin cooling to permit continuous operation while running dry. Pump shall have an oil filled seal chamber with two (2) mechanical seals.
  - f. Control system shall include sealed mercury switches in a polypropylene float set at the NEMA 1, simplex control panel, one (1) fusible disconnect switch, one (1) magnetic starter one (1) overload reset button, one (1) running light for pump motor, one (1) control circuit transformer, one (1) Test-Off-Automatic selector switch, alarm light and alarm horn with silencing switch.
  - g. Clear water sump shall be cast iron with tapped flanged or precast reinforced concrete, high strength plastic fiberglass reinforced.
2. Sanitary Waste Equipment
  - a. Kitchen Grease Interceptor
    - i. Exterior Interceptor; Prefabricated concrete reinforced tank, minimum 3" thick of 4500 psi reinforced concrete with 6" x 6" ten gauge mesh.
    - ii. Interior Interceptor: Acid resisting epoxy coated interior and exterior grease trap, internal air relief by-pass, bronze cleanout plug, visible double wall trap seal, gas and watertight gasketed non-skid cover with stainless steel fasteners.
3. Simplex Sanitary Lift Station (Clear Water Only)
  - a. Pump to be complete with built-in capacitor and starting switch, #303 Stainless Steel shaft, ball bearings, mechanical seal and strainer.
  - b. NEMA 1 alarm panel including cable, float, alarm light and alarm horn with silencing switch.
  - c. Control system with control box, two float switches with cable and a heavy duty contactor.
  - d. Sanitary sump shall be cast iron with tapped flange or precast reinforced concrete or high strength plastic fiberglass reinforced supply gasketed fittings to seal gas-tight all pipes, wires, etc. that penetrate the sump cover.
4. Simplex Sanitary Lift Station
  - a. Heavy duty screenless non-clog submersible sewage lift pumps. NEMA 6 air filled submersible type having cast iron shell with special fin cooling to permit continuous operation while running dry, oil filled seal chamber with two (2) mechanical seals, capable of passing 2" solids.

- b. Control system shall include sealed mercury switches in a polypropylene float set, NEMA 1 simplex control panel, one (1) fusible disconnect switch, one (1) magnetic starter, one (1) overload reset button, one (1) running light for pump motor, one (1) control circuit transformer, one (1) Test-Off-Automatic selector switch, alarm light mounted on the panel door and a NEMA 1 alarm panel.
  - c. Sump shall be cast iron with tapped flange or precast reinforced concrete or high strength plastic fiberglass reinforced, supply gasketed fittings to seal gas-tight all pipes.
5. Domestic Hot Water Heating
- a. Steam
    - i. Buildings connected to the campus steam distribution system shall utilize semi-instantaneous steam domestic water heaters.
    - ii. Domestic hot water heat exchangers shall be installed in pairs when possible to maintain hot water production during cleaning. This is especially critical in laboratory buildings and residence halls. Each heat exchanger shall be sized to handle at least two thirds of the total peak load.
  - b. Natural Gas
    - i. Utilize natural gas fired domestic water heaters where campus steam is not available.
    - ii. Provide water heaters with Performance Efficiencies not less than prescribed in ASHRAE 90A, "Energy Conservation in New Building Design."
  - c. Electric domestic water heaters shall not be permitted unless supported by an economic evaluation incorporating first cost, operating costs and life cycle costs.
  - d. Instantaneous water heaters are not permitted as a primary source. For incidental use, sporadic equipment demands, or remote individual fixtures (i.e. lavatory, sink, shower, service sink), the use of instantaneous water heaters is permitted. Point of use instantaneous water heaters are permitted for use at emergency fixtures to supply "tepid water" immediately at the emergency fixture or group of emergency fixtures.
  - e. The use of thermostatic mixing valves is required to maintain hot water temperature consistent with the plumbing code requirement to hand washing sinks and showers. Use of a single valve tempering device is preferred. Other devices will be considered for use, but approval by BGSU is required. Selection of tempering devices shall be chosen with consideration of the high mineral content of the city of Bowling Green water provided to the BGSU Main Campus. Provide shut off valves, unions and check valves on all incoming and outgoing piping. Provide a bypass line with shut off valve to allow removal of the mixing valve while maintaining hot water in service.
  - f. The domestic hot water system shall use a maintenance free (no oil) re-circulation pump to keep the mains warm at all times. The use of heating cable is not acceptable. The on/off operation of the domestic hot water re-circulation pumps shall be controlled by a time clock or the temperature control system.

- g. Piping to semi-instantaneous heaters shall be installed in a manner to have clear access for tube repairs and cleaning. Valving shall allow servicing of one heater while the other remains active. Piping connections to heaters shall be made with copper/brass flanged connections to avoid corrosion and allow easy removal,
- h. A bladder type expansion tank shall be installed on all domestic hot water systems. Expansion tank to be tagged for system operating pressure.

## 224000 - PLUMBING FIXTURES

1. General
  - a. All plumbing fixtures shall be of one manufacturer insofar as possible and white in color.
  - b. Set floor sinks in leveling bed of cement grout.
  - c. Water supply (hot and/or cold) to lavatories, sinks, drinking fountains, etc., shall have angle stops with loose key handles in an accessible location.
  - d. Install escutcheons at each wall, floor and ceiling penetration in exposed finished locations and within cabinets and millwork.
  - e. Seal fixtures to walls, floors and counters using a sanitary-type, one-part, mildew-resistant, silicone sealant with sealant.
2. Shower drain traps shall be 4" diameter only, no exceptions. 3" acceptable if space limitations dictate. Shower drain shall have square 6"x6" nickel bronze top. All shower drain traps shall be accessible for removal and cleaning. Use access panels where necessary.
  - a. Lavatory drains shall be separately piped to main horizontal branches only. Combining two or more lavatories to one drop to main is not allowed.
  - b. All lavatories and sink traps shall have cleanouts in bottom of trap.
3. Water closets shall be china, white, standard flush valve, **wall hung only**, siphon jet design and low water consumption type. Floor set toilets shall only be used in situations where there are no other options to provide wall hung type. Approval to use floor set toilets will still be required. Provide hard wired sensor flush valves for most Campus buildings except residence halls. Residence Halls shall have manual flush valves unless prior approval is given to use other type devices.
4. Toilets seats.
  - a. Black seats shall be used with open front without cover. In special circumstances, possibly some residence halls, white seats may be used if approved by owner only.
  - b. Commercial, heavy duty solid plastic, elongated, self-sustaining check hinges.
5. Urinals shall be china, white, standard flush valve, wall hung, and low water consumption type. Provide hard wired sensor flush valves for most Campus buildings except residence halls. Residence Halls shall have manual flush valves unless prior approval is given to use other type devices.
6. Lavatories except in Residence Halls shall have AC powered infrared faucet with the electronics/solenoid built into the spout. Temperature control shall be integral with the faucet or remote mixed.

7. Lavatories in Residence Halls shall have separate lever handles for hot and cold water. Single lever faucets shall be avoided due to the likelihood of damage/vandalization.
8. All lavatory drains shall be grid type. Pop up style drains are not acceptable unless approved by owner.
9. All lavatory and shower faucets shall be ADA compliant, non-wrist blade type if at all possible.
10. Showers shall have a hot and cold, single lever pressure balancing valve with a vandal-resistant head and a stainless steel if available/metal wall plate. Plastic wall plates are not acceptable and long length single arm temperature adjusting handles should be avoided. (Note: all shower valves shall have both check and stop valves on the cold and hot water connections to the valves and preferably loose rather than integral to the valves.)
11. Residence Halls drinking water coolers/fountains shall be handicap accessible and fully recessed. Details are available from The BGSU Office of Design and Construction.
12. Water cooler with bottle filling station shall be ADA compliant, stainless steel with integral drain, 1.5 gpm with 20-second auto shut-off.
13. Stainless steel sinks when specified shall be 18-gauge, 302 or 304 stainless steel.
14. Service sinks shall be floor-mounted, molded stone, 10 inches high, with a wall-mounted faucet.
15. Science lab sinks shall be connected with acid-resistant material. The science casework manufacturer shall provide sinks.
16. All plumbing fixtures and trim designed or designated for use by the handicapped shall meet the Americans with Disabilities Act guidelines.
17. All lavatories, water closets, and urinals shall have wall carriers.

End of Section