

DOCUMENT RESUME

ED 216 180

CE 032 497

TITLE Military Curriculum Materials for Vocational and Technical Education. Engine Principles, 8-3. Edition 5.

INSTITUTION Ohio State Univ., Columbus. National Center for Research in Vocational Education.

SPONS AGENCY Office of Education (DHEW), Washington, D.C.

PUB DATE Dec 75

NOTE 150p.

EDRS PRICE MF01/PC06 Plus Postage.

DESCRIPTORS Curriculum; *Engines; Independent Study; Postsecondary Education; *Programed Instructional Materials; Secondary Education; Technical Education; Units of Study; *Vocational Education

IDENTIFIERS Military Curriculum Project

ABSTRACT

This individualized, self-paced course for independent study in engine principles has been adapted from military curriculum materials for vocational education use. The course provides the student with basic information on engine principles including different kinds of combustion engines, lubrication systems, and cooling systems. It is organized into the following five lessons: introduction to internal combustion engines; spark ignition engines; compression ignition and gas turbine engines; engine lubrication systems; and engine cooling systems. Each lesson contains objectives, text readings, and review exercises. The text is coded, and the answers to the exercises are keyed to the text. A final examination, without answers, is provided. The course can be used as a supplemental unit with any engine repair or design course. (KC)

 * Reproductions supplied by EDRS are the best that can be made *
 * from the original document. *

MILITARY CURRICULUM MATERIALS

The military-developed curriculum materials in this course package were selected by the National Center for Research in Vocational Education Military Curriculum Project for dissemination to the six regional Curriculum Coordination Centers and other instructional materials agencies. The purpose of disseminating these courses was to make curriculum materials developed by the military more accessible to vocational educators in the civilian setting.

The course materials were acquired, evaluated by project staff and practitioners in the field, and prepared for dissemination. Materials which were specific to the military were deleted, copyrighted materials were either omitted or approval for their use was obtained. These course packages contain curriculum resource materials which can be adapted to support vocational instruction and curriculum development.

SUBCOURSE
ODO607

EDITION
5

ENGINE PRINCIPLES

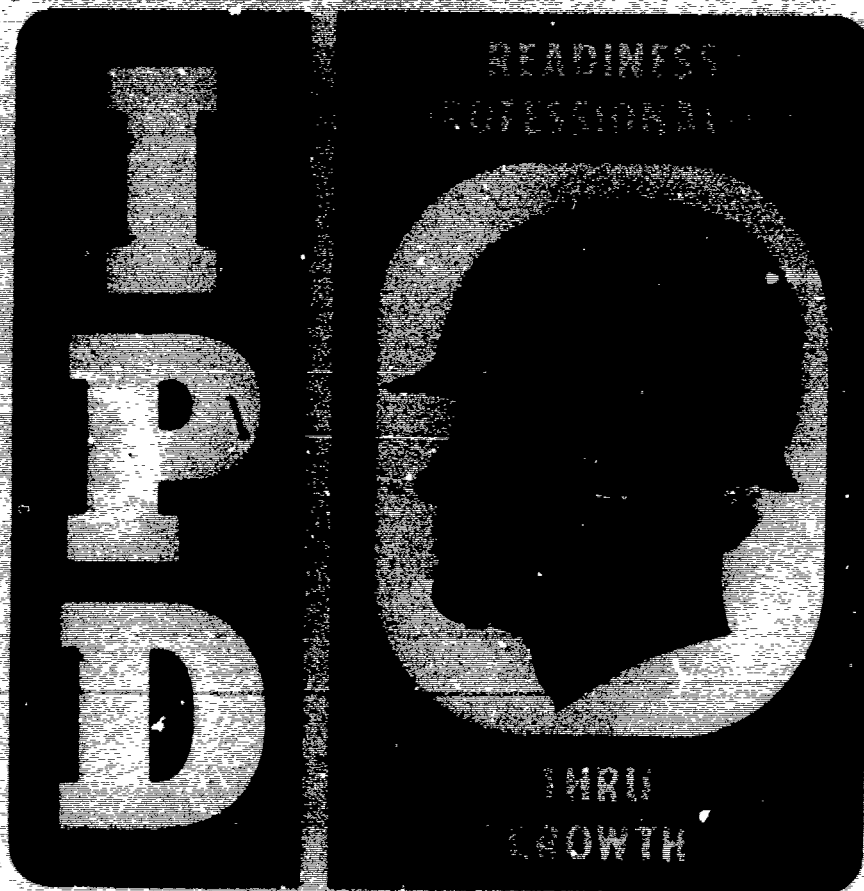

ARMY CORRESPONDENCE COURSE PROGRAM

The National Center Mission Statement

The National Center for Research in Vocational Education's mission is to increase the ability of diverse agencies, institutions, and organizations to solve educational problems relating to individual career planning, preparation, and progression. The National Center fulfills its mission by:

- Generating knowledge through research
- Developing educational programs and products
- Evaluating individual program needs and outcomes
- Installing educational programs and products
- Operating information systems and services
- Conducting leadership development and training programs

FOR FURTHER INFORMATION ABOUT Military Curriculum Materials

WRITE OR CALL

Program Information Office
The National Center for Research in Vocational
Education
The Ohio State University
1960 Kenny Road, Columbus, Ohio 43210
Telephone: 614/486-3655 or Toll Free 800/
848-4815 within the continental U.S.
(except Ohio)



Military Curriculum Materials for Vocational and Technical Education

Information and Field
Services Division

The National Center for Research
in Vocational Education



Military Curriculum Materials Dissemination Is . . .

an activity to increase the accessibility of military-developed curriculum materials to vocational and technical educators.

This project, funded by the U.S. Office of Education, includes the identification and acquisition of curriculum materials in print form from the Coast Guard, Air Force, Army, Marine Corps and Navy.

Access to military curriculum materials is provided through a "Joint Memorandum of Understanding" between the U.S. Office of Education and the Department of Defense.

The acquired materials are reviewed by staff and subject matter specialists, and courses deemed applicable to vocational and technical education are selected for dissemination.

The National Center for Research in Vocational Education is the U.S. Office of Education's designated representative to acquire the materials and conduct the project activities.

Project Staff:

Wesley E. Budke, Ph.D., Director
National Center Clearinghouse

Shirley A. Chase, Ph.D.
Project Director

What Materials Are Available?

One hundred twenty courses on microfiche (thirteen in paper form) and descriptions of each have been provided to the vocational Curriculum Coordination Centers and other instructional materials agencies for dissemination.

Course materials include programmed instruction, curriculum outlines, instructor guides, student workbooks and technical manuals.

The 120 courses represent the following sixteen vocational subject areas:

Agriculture	Food Service
Aviation	Health
Building & Construction	Heating & Air Conditioning
Trades	Machine Shop Management & Supervision
Clerical Occupations	Meteorology & Navigation
Communications	Photography
Drafting	Public Service
Electronics	
Engine Mechanics	

The number of courses and the subject areas represented will expand as additional materials with application to vocational and technical education are identified and selected for dissemination.

How Can These Materials Be Obtained?

Contact the Curriculum Coordination Center in your region for information on obtaining materials (e.g., availability and cost). They will respond to your request directly or refer you to an instructional materials agency closer to you.

CURRICULUM COORDINATION CENTERS

EAST CENTRAL

Rebecca S. Douglass
Director
100 North First Street
Springfield, IL 62777
217/782-0759

MIDWEST

Robert Patton
Director
1515 West Sixth Ave.
Stillwater, OK 74704
405/377-2000

NORTHEAST

Joseph F. Kelly, Ph.D.
Director
225 West State Street
Trenton, NJ 08625
609/292-6562

NORTHWEST

William Daniels
Director
Building 17
Airdustrial Park
Olympia, WA 98504
206/753-0879

SOUTHEAST

James F. Shill, Ph.D.
Director
Mississippi State University
Drawer DX
Mississippi State, MS 39762
601/325-2510

WESTERN

Lawrence F. H. Zane, Ph.D.
Director
1776 University Ave.
Honolulu, HI 96822
808/948-7834

Developed by:

United States Army

**Development and
Review Dates:**

December 1975

Occupational Area:

Engine Mechanics

Print Pages:

140

Availability:

ERIC

National Center Clearinghouse

Suggested Background:

None

Target Audiences:

Grades 10-Adult

Organization of Materials:

Text materials, objectives, review exercises with answers, course examination

Type of Instruction:

Individualized, self-paced

Type of Materials:**No. of Pages:****Average
Completion Time:****Engine Principles**

Lesson 1 - Introduction to Internal Combustion Engines	22	Flexible
Lesson 2 - Spark Ignition Engines	26	Flexible
Lesson 3 - Compression Ignition and Gas Turbine Engines	28	Flexible
Lesson 4 - Engine Lubricating Systems	25	Flexible
Lesson 5 - Engine Cooling Systems	18	Flexible
Examination, Review Exercise Answers	14	

Supplementary Materials Required:

None

Course Description:

This course provides the student with basic information on engine principles including different kinds of combustion engines, lubrication systems and cooling systems. It is organized into five lessons.

- Lesson 1 - Introduction to Internal Combustion Engines covers basic engine components; principles of 2- and 4-stroke cycle engines; basic engine operation; advantages of multicylinder engines; engine measurements, output and efficiency; and the classification of engines.
- Lesson 2 - Spark Ignition Engines discusses construction of typical spark ignition engines.
- Lesson 3 - Compression Ignition and Gas Turbine Engines explains the principles of diesel, multifuel, and gas turbine engines and makes a comparison of compression ignition and spark ignition engines.
- Lesson 4 - Engine Lubrication Systems discusses principles of lubrication, types of engine lubrication systems, military lubricants and lubrication, and effects of weather on lubricating oils.
- Lesson 5 - Engine Cooling Systems covers construction and operation of liquid and air-cooled engines, coolants used, and a comparison of the two types of cooling.

This course is designed for student self-study and evaluation. Each lesson contains objectives, text readings, and review exercises. The text is coded and the answers to the exercises are keyed to the text. A final examination is provided but no answers are available. This course would be a good supplemental unit with any engine repair or design course.

TABLE OF CONTENTS

Lesson

1	Introduction to Internal Combustion Engines	3
2	Spark Ignition Engines	25
3	Compression Ignition and Gas Turbine Engines	51
4	Engine Lubrication Systems	79
5	Engine Cooling Systems	104
	Exercise Response List	122
	Examination	132

CORRESPONDENCE COURSE
of the
US ARMY ORDNANCE
CENTER AND SCHOOL



ORDNANCE SUBCOURSE NUMBER
607

ENGINE PRINCIPLES

EDITION 5

DECEMBER 1975

-- IMPORTANT --
STUDY THIS SHEET

Before beginning the subcourse

General

Your cooperation in following these instructions will

- enable you to make the maximum rating commensurate with your ability
- help us to process your lessons promptly and efficiently.

Scan the CHECKLIST OF TEXTS AND MATERIALS FURNISHED.
Scan the INTRODUCTION to the subcourse.

Procedure

- Beginning with Lesson 1, scan the LESSON ASSIGNMENT SHEET. It lists the lesson title, lesson objective, credit hours required, texts required, and suggestions.
- When the words STUDY TEXT follow the Lesson Assignment Sheet, the information you must digest is found in a text(s), memorandum, pamphlet, and/or other separate material(s).
- When the words STUDY GUIDE AND ATTACHED MEMORANDUM follow the Lesson Assignment Sheet, the information you must digest is either
 - found in texts and in this subcourse booklet, or
 - found entirely in this booklet.
- When you are referred to a paragraph or an illustration in a manual, turn to the specified paragraph at once and scan or study the text assignment as directed. Continue this procedure until you reach the LESSON EXERCISE.

Lesson Exercise

- Study and answer each question.
- CAUTION: Check to insure that all questions have been answered.
- Your answers MUST be based on subcourse materials, NOT on your experience or opinions.

Assistance

If you require explanation or clarification of subcourse materials or questions, write to the U. S. Army Ordnance Center and School, ATTN: Course Development Directorate. Constructive comments are appreciated.

Include NAME and SOCIAL SECURITY ACCOUNT NUMBER on all correspondence.

CORRESPONDENCE COURSE
of the
US ARMY ORDNANCE
CENTER AND SCHOOL



ORDNANCE SUBCOURSE NUMBER 607, ENGINE PRINCIPLES
(15 Credit Hours)

INTRODUCTION

Remarkable progress has been made in engine development since the experiments of Dr. N. A. Otto, who, in 1876, applied the principle of the four-stroke cycle to engines. The first engines were crude machines delivering only a very limited horsepower. Today's engines are modern machines designed in shape and horsepower output for a specific application.

An automotive engine is defined simply as a machine that converts heat energy to mechanical energy. To fulfill this purpose, the engine may take any one of the following forms:

The reciprocating engine is basically a device for converting the high internal energy of hot gases (produced by the combustion of a hydrocarbon fuel in air) to mechanical energy. This is done by transforming the linear motion of the piston produced by the force of expanding gases to rotary motion of the crankshaft.

The turbine engine operates on the principle of expanding gases forcing a turbine or fan to rotate. This form of power is very similar to that generated by a windmill.

The jet engine is rapidly being applied in more and more areas where linear thrust is required. These engines utilize expanding gases also, and operate on the principle that for every action there is an equal and opposite reaction.

The energy required to power the automotive end items contained in today's US Army inventory is generated primarily by reciprocating engines; however, turbine engines are being tested for application in future vehicles.

This subcourse is designed to provide you with a general knowledge of the construction and operation of gasoline, diesel, multifuel, and turbine engines, as well as the cooling and lubrication systems utilized on these engines. It is applicable to personnel performing duties in or having MOS's 4803, 4815, 631A, and the 63B, 63C, 63F, 63G, 63H, and 63Z series. The subcourse consists of five lessons and an examination organized as follows:

Lesson 1 Introduction to Internal Combustion Engines
Scope--Basic engine components, principles of 2- and 4-stroke cycle engines, basic engine operation, advantages of multicylinder engines, engine measurements, output and efficiency, and the classification of engines.

Lesson 2 Spark Ignition Engines
Scope--Construction of typical spark ignition engines.

2

Lesson 3 Compression Ignition and Gas Turbine Engines

Scope--Principles of diesel, multifuel, and gas turbine engines, and a comparison of compression ignition and spark ignition engines.

Lesson 4 Engine Lubricating Systems

Scope--Principles of lubrication, types of engine lubricating systems, military lubricants and lubrication, and effects of weather on lubricating oils.

Lesson 5 Engine Cooling Systems

Scope--Construction and operation of liquid- and air-cooled engines, coolants used, and a comparison of the two types of cooling.

Examination

CHECKLIST OF TEXTS AND MATERIALS FURNISHED

Ordnance Subcourse No 607
February 1976

No texts, other than the Attached Memorandums in lessons, are used in support of this subcourse. Therefore, you are not required to return any texts to the US Army Ordnance Center and School.

This subcourse may contain errata sheets. Make certain that you post all necessary changes before beginning.

Note. - Any references cited in this subcourse are general references and are not furnished.

The following publications were used in the preparation of this subcourse:

TM 9-2320-209-20	Chassis, Truck, 2-1/2-Ton, 6x6	Apr 65
TM 9-2320-211-10	Chassis, Truck, 5-Ton, 6x6	Apr 73
TM 9-2320-215-24	Truck, Cargo, 2-1/2-Ton, 6x6	Apr 70
TM 9-2815-200-34	Engine, Diesel, 12-Cylinder Assembly	Feb 63
TM 9-2815-210-35	Engine, Diesel (Multifuel) Turbo-Supercharged, Water-Cooled, 6-Cylinder Assembly	Sep 64
TM 9-8000	Principles of Automotive Vehicles	Jan 56

CORRESPONDENCE COURSE
of the
US ARMY ORDNANCE
CENTER AND SCHOOL



3

LESSON ASSIGNMENT SHEET

Ordnance Subcourse No 607. Engine Principles
Lesson 1 Introduction to Internal Combustion Engines
Credit Hours Three
Lesson Objective After studying this lesson you will be able to describe basic engine components, principles of 2- and 4-stroke-cycle engines, basic engine operation, advantages of multicylinder engines, engine measurements, output and efficiency, and the classification of engines.
Text Attached Memorandum
Materials Required Answer sheet and exercise response list.
Suggestions. None

STUDY GUIDE AND ATTACHED MEMORANDUM

1. INTRODUCTION. The manufacture of automotive vehicles today is by far the largest industry in existence in the free world. Nineteen out of twenty people, past the age of 16 years, who reside in the United States either have operated or will operate an automotive vehicle. By the same token, four out of five people in the United States will at some time own an automotive vehicle. These vehicles are all propelled by some form of an internal combustion engine. Considering the effect that the automobile has on our everyday lives, it behooves each of us to attain at least a familiarization of the operation of an internal combustion engine.

2. COMPONENTS OF A BASIC ENGINE. An internal combustion engine (fig 1) is designed to produce a rotary mechanical motion from the expansion of gases. To accomplish this, there is a requirement for the following components in a basic one-cylinder engine:

a. Engine block. The engine block is the foundation for mounting the required components of an engine. It is normally constructed of cast iron and contains a machined cylinder that houses the piston.

OS 607, 1-P1
December 1975

4.

b. Cylinder and piston. The piston wall forms a slide fit in the cylinder so that it is free to move up and down. The top end of the piston is closed and the upper portion of the piston wall is grooved (fig 2) to accept rings that assist in preventing pressures created above the piston from escaping past the piston walls into the area below the piston. One or more of the grooves contain an oil ring, which will be discussed in a later lesson, and the other grooves (those nearest the top of the piston) contain the compression rings.

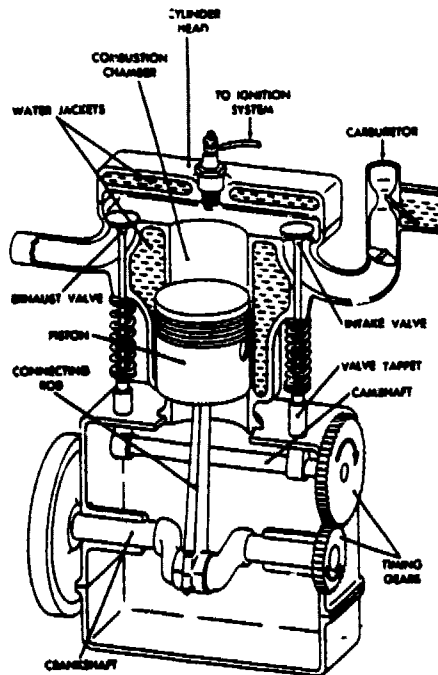

Figure 1. Single-cylinder, 4-stroke-cycle, internal combustion, gasoline engine--cutaway view.

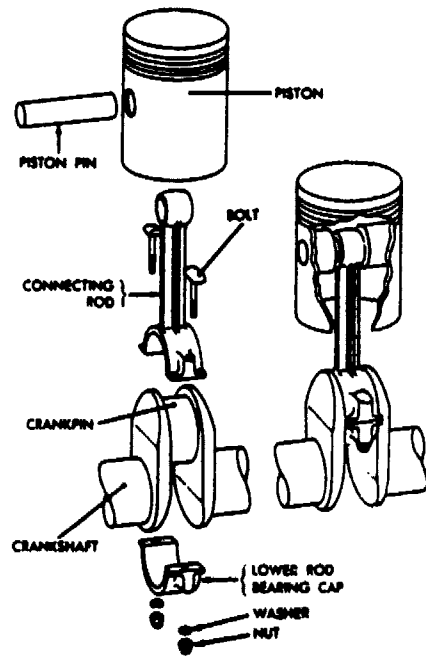

Figure 2. Piston, connecting rod, and piston pin.

c. Crankshaft. The crankshaft serves several purposes as follows:

(1) It contains an offset called a crank for producing rotary motion from the reciprocating motion of the piston. The offset contains a machined bearing surface called the crankpin (fig 2) to provide a connecting point between the piston and crankshaft. This type of offset on a shaft provides the same type leverage that is gained by using a regular handcrank to turn or wind something. The longer the throw is, the greater the leverage will be. However, it must be remembered that the length of the throw also determines how far the piston must travel up and down.

(2) The two ends of the crankshaft are provided with machined bearing surfaces for securing the crankshaft to the block. These surfaces, when mounted with bearings, provide a stable mounting for the crankshaft and allow rotary motion with a minimum of friction.

(3) One end of the crankshaft carries a timing gear for driving the mechanism that will open and close the valves at the proper time.

OS 607, 1-P2

5

(4) The other end has a mounting surface for a flywheel-type arrangement. The flywheel provides the momentum required to keep the shaft rotating and also has a tendency to smooth out the jerking motion caused when the engine fires (passes through the power phase). The flywheel end normally provides the mounting surface for connecting the engine to the load it will drive.

d. Connecting rod (fig 2). The reciprocating (up and down) motion of the piston is transmitted to the throw of the crankshaft by a linkage called the connecting rod. It is readily understandable that because the throw of the crankshaft is rotating and that the piston is not free to move sideways, it is necessary to provide a bearing connection on both ends of the connecting rod that connects the two items. The piston end of the connecting rod contains a bearing surface for the piston pin (commonly called the wrist-pin). The pin has a floating mounting on two sides of the piston and passes through the bearing surface on the upper end of the connecting rod. The crankshaft end of the connecting rod is molded to fit one-half of the bearing surface of the crankpin. A bearing cap over the lower half of the crankpin bearing surface is bolted to the connecting rod. The clearance of these bearing surfaces is critical; if they are too tight they will be improperly lubricated, which will cause them to heat and seize, and if they are too loose they will soon wear out of round.

e. Cylinder head. The top end of the cylinder is closed off with a cylinder head that is secured to the block with several head bolts which compress the head gasket between the head and block. This arrangement provides a seal that prevents any loss of pressures that are created in the cylinder. The head also provides passages for the fuel mixture supply and escape of exhaust gases. At a point above the piston, the head contains a threaded area that accepts a spark plug for providing ignition.

f. Valve train. The valve train consists of an intake and an exhaust valve, valve springs, valve tappets, and camshaft. The heads of the valves are designed to fit a valve seat in such a manner that they create a metal-to-metal seal when closed. The valve stems project down through valve guides in the block (provided to assure stability of valve alignment with the seat) and rest on a valve tappet. The valve springs encircle the valve stem and provide tension that tends to keep the valve head on its seat. The camshaft contains a cam lift, commonly called cam lobe, for each valve. The cams are spaced 90° apart. The camshaft gear, which is in constant mesh with the crankshaft timing gear, contains twice as many teeth as the crankshaft gear and will rotate at one-half the speed of the crankshaft. As the camshaft rotates, the cams will force the tappets up, thereby forcing the valves from their seats. As the camshaft continues to rotate, the cams will move away from the tappets and the compressed valve springs will force the valve heads back on their seats.

g. Accessory systems. In addition to the basic components discussed above, the following systems are also required:

(1) Fuel system. A means of mixing fuel and air in correct quantities. This system must also include the components necessary to convey the fuel-air mixture to the cylinders.

(2) Ignition system. A group of components designed to produce a high voltage spark across the spark plug electrodes at the proper time.

(3) Exhaust system. A group of components designed to convey the exhaust gases away from the cylinder, muffle the distinct popping noise of combustion, and prevent live sparks from causing a fire.

6

(4) Cooling system. The components required to keep the engine block, cylinder head, and valves cool. This can be either in the form of air cooling or liquid cooling.

(5) Lubrication system. A combination of components designed to keep all moving parts supplied with the proper amount of lubricant.

3. THE 4-STROKE CYCLE. In 1876 Dr. N. A. Otto applied the principles of the 4-stroke cycle (fig 3) to operate a gasoline engine. As a result, the 4-stroke cycle is commonly called the Otto cycle. Frequently we will hear the term "4-cycle engine"; however, this is a misnomer and is interpreted to mean 4-stroke cycle.

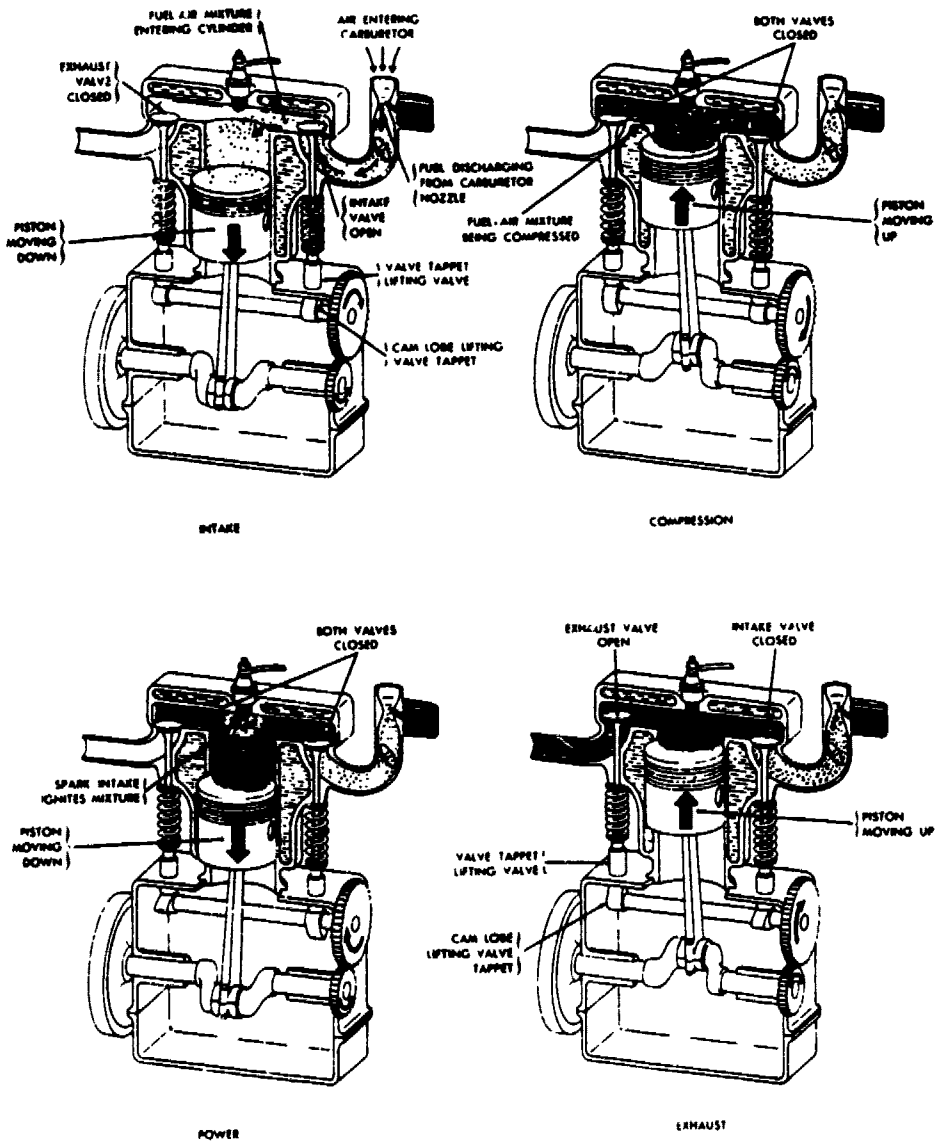

Figure 3. The four strokes in the 4-stroke-cycle gasoline engine.

OS 607, 1-P4

a. General. The term "4-stroke cycle" pertains to the number of times the piston will move up and down between power strokes. The strokes are called intake, compression, power, and exhaust and will be discussed in that order. At this point, it must be considered that for each two strokes (one up and one down) of the piston, the crankshaft will revolve once. Therefore, for each 4-stroke cycle the crankshaft will complete two revolutions. As the camshaft rotates at one-half the speed of the crankshaft (para 2f), the cams of the camshaft will lift each valve from its seat once during each cycle.

b. Intake stroke. It is common knowledge that if a piston is pulled rapidly from a sealed cylinder, a partial vacuum will be created in the cylinder. This principle is illustrated in figure 4. Suction on the straw tends to create a pressure in the mouth and straw that is less than the atmospheric pressure surrounding the straw, liquid, and glass. Because of this difference in pressure, the atmospheric pressure against the liquid forces the liquid through the straw and into the mouth. Applying this principle to the intake stroke, it can be seen that the atmospheric pressure in the cylinder ahead of the piston tends to decrease as the piston is pulled down. At this time, the rotation of the camshaft is causing a cam to push the intake valve up and away from its seat. Atmospheric pressure around the carburetor causes air to rush through the carburetor horn, siphon fuel from the carburetor on its way, and rush through the intake manifold and open valve into the low pressure area of the cylinder. The fuel-air mixture after passing through the carburetor is approximately 1 part fuel to 15 parts air. As the crankshaft continues to rotate it will turn the camshaft, thus allowing the intake valve to close when the piston is near the bottom position and ending its intake stroke. The fuel-air mixture is then trapped in the cylinder.



Figure 4. Partial vacuum produced by suction.

c. Compression stroke. The continued rotation of the crankshaft starts the piston on its upward stroke. Due to both the intake and exhaust valves being closed at this time, there is no escape for the fuel-air mixture and it compresses as the piston moves up. This is an opportune time to discuss what is meant by the term "compression ratio." We often hear that an engine has a 7:1 or 10:1 compression ratio. This means that the volume of fuel-air mixture that enters the cylinder during the intake stroke is compressed during the compression stroke to one-seventh or one-tenth of the original volume. As the mixture is compressed its temperature rises, it becomes more combustible, and the energy in the mixture is concentrated in a smaller area.

8

d. Power stroke. When the piston passes over top dead center (TDC), the point where the piston has reached the top of its compression stroke, the ignition system will cause a spark to jump between the electrodes of the spark plug. The spark plug protrudes through the cylinder head in such a manner that the electrodes are in the area where the fuel-air mixture is compressed. The spark will ignite the mixture. The mixture burns so rapidly that it is said to explode. Pressures in the cylinder will approach as much as 500 PSI at the peak of combustion. Such pressure acting against the total surface of the piston top drives the piston down with terrific force. This force is imparted to the crankshaft through the piston connecting rod, creating a powerful twist on the crankshaft.

e. Exhaust stroke. Now, the continued rotation of the crankshaft will start the piston on its upward stroke. However, by this time the timing gears have rotated the camshaft so that a cam is pushing the exhaust valve up from its seat. As the piston continues upward it forces the burned gases out of the exhaust valve through the exhaust pipe and the muffler. When the piston reaches the top of its stroke, the camshaft will have turned sufficiently so that the cam allows the exhaust valve to return to its seat and the cycle is ready to start again.

f. Four-stroke-cycle engine operation.

(1) Cold engine starting. When the engine is cold, the starting system must pass the piston through several cycles before the engine will start. Several things are the cause of this:

(a) When the engine stands for long periods of time without operating, the lubrication film on the cylinder walls depletes or stiffens if the weather is cold. As the piston comes down on the intake stroke a certain amount of leakage will take place between the piston rings and cylinder walls. This reduces the vacuum created which, in turn, reduces the velocity of air rushing through the carburetor.

(b) Also, because the engine is cold, the compressed fuel-air mixture at the end of the compression stroke is not of a suitable temperature for proper combustion. After the piston passes through several cycles, the compression rises. This is due to the oil forming a better seal between the rings and cylinder walls.

(c) After the piston passes through several strokes the lubricant is also freed to a certain extent, allowing the starting system to rotate the crankshaft faster.

(d) As soon as the proper conditions exist at the end of the compression stroke, the fuel-air mixture will ignite and drive the piston down with sufficient force to carry it through the next three strokes and repeat the cycle.

(2) Warm engine starting. When the starting system rotates the crankshaft of a warm engine sufficiently to pass the piston through an intake and compression stroke, the mixture will normally ignite during the first cycle and start the engine.

4. THE 2-STROKE CYCLE.

a. General. In the 2-stroke engine (fig 5), the entire series of events takes place during one revolution of the crankshaft. In other words, the fuel intake, mixture compression, combustion, and exhaust occur as the piston goes up once and comes down once. The 2-cycle engine differs from the 4-cycle engine in that ports on the side of the cylinder are used in place of valves. This deletes the necessity for the entire valve train, including the camshaft.

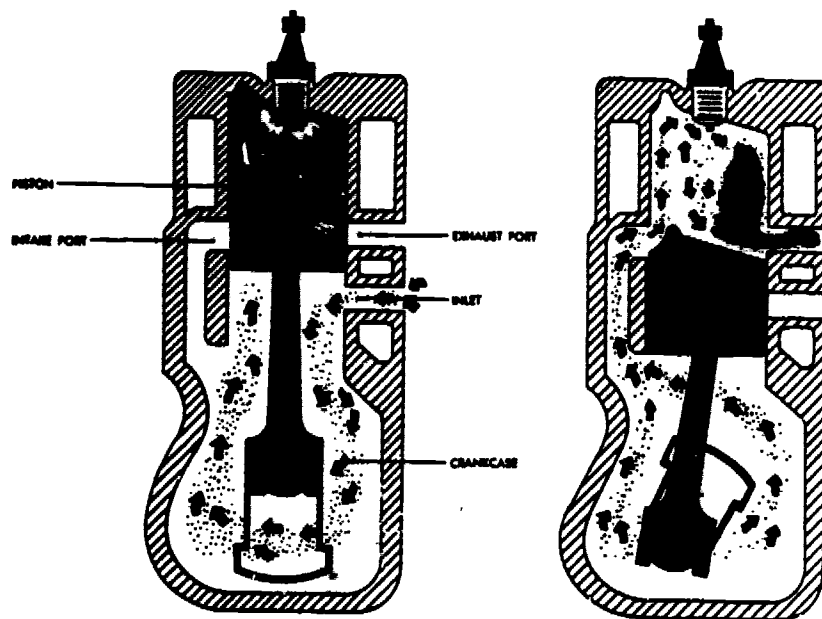

Figure 5. Events in a 2-stroke-cycle, internal combustion engine.

b. Operation. Every other stroke on this type of engine is a power stroke. As the piston moves down on its power stroke, it first uncovers the exhaust port to let burned gases escape and then uncovers the intake port to allow a new fuel-air mixture to enter the combustion chamber. On the upward stroke, the piston covers both ports and, at the same time, compresses the new mixture in preparation for ignition and another power stroke. In the engine shown in figure 5, the piston is so shaped that the incoming fuel-air mixture is directed upward, thereby sweeping out ahead of it the burned exhaust gases. Also, there is an inlet into the crankcase through which the fuel-air mixture passes before it enters the cylinder. This inlet is opened as the piston moves upward, but it is sealed off as the piston moves downward on the power stroke. The downward moving piston slightly compresses the mixture in the crankcase, thus giving the mixture sufficient pressure to pass rapidly through the intake port as the piston clears this port. This improves the "sweeping-out," or scavenging, effect of the mixture as it enters and clears the burned gases from the cylinder through the exhaust port.

5. COMPARISON OF 2-STROKE-CYCLE AND 4-STROKE-CYCLE ENGINES. It might appear that a 2-stroke-cycle engine could produce twice as much horsepower as a 4-stroke-cycle engine of the same size operating at the same speed. However, this is not the case. In order to scavenge the burned gases at the end of the power stroke and during the time that both the intake and exhaust ports are open, the fresh fuel-air mixture rushes into and through the cylinder. A portion of the fresh fuel-air mixture mingles with the burned gases and is carried out the exhaust port. Also, due to the much shorter period that the intake port is open (as compared to the period that the intake valve in a 4-stroke-cycle engine is open), a relatively smaller amount of fuel-air mixture is admitted. Hence, with less fuel-air mixture, less power per power stroke is produced as compared to the power produced in a 4-stroke-cycle engine of like size, operating at the same speed, and with other conditions being the same. To increase the amount of fuel-air mixture, auxiliary devices are used with some 2-stroke-cycle engines to assure delivery of greater amounts of mixture into the cylinder.

6. ADVANTAGES OF MULTICYLINDER ENGINES.

a. Power increase. In early automotive vehicles, 1-cylinder and some 3-cylinder engines were used, but the many advantages of a larger number of cylinders soon led to the adoption of 4-, 6-, 8-, 12-, and 16-cylinder engines. Although the power stroke of each piston theoretically continues for 180° of crankshaft rotation, best results can be obtained if the exhaust valve is opened when the power stroke has completed about four-fifths of its travel. Therefore, the period that power is delivered during 720° of crankshaft rotation, or one 4-stroke cycle, will be 145° multiplied by the number of cylinders in the engine. For example, if an engine has two cylinders, power will be transmitted for 290° of the 720° of travel necessary to complete the four events of the cycle. The flywheel must supply power for the remaining 430° of crankshaft travel.

b. Power overlap. As cylinders are added to an engine, each one must complete the four steps of the cycle during two revolutions of the crankshaft. The number of power impulses for each revolution also increases, producing smoother operation. If there are more than four cylinders, the power strokes overlap as shown in figure 6. The length of overlap increases with the number of cylinders. The diagram for the 6-cylinder engine shows a new power stroke starting each 120° of crankshaft rotation and lasting for four-fifths of a stroke or 145° . This provides an overlap of 25° . In the 8-cylinder engine, a power stroke starts every 90° and continues for 145° , resulting in a 55° overlap of power. Because the cylinders fire at regular intervals, the power overlap will be the same regardless of firing order and will apply to either in-line or V-type engines.

7. CLASSIFICATION OF ENGINES.

a. General. Automotive engines may be classified according to the type of fuel they use, type of cooling employed, or valve and cylinder arrangement. They all operate on the internal combustion principle, but the application of basic principles of construction to particular needs or systems of manufacture has caused certain designs to be recognized as conventional. The most common method of classification is by type of fuel used; i.e., whether the engine burns gasoline or diesel fuel.

b. Cooling. Engines are classified as to whether they are air cooled or liquid cooled. All engines are cooled by air to some extent, but air-cooled engines are those in which air is the only external cooling medium. Lubricating oil and fuel help somewhat to cool all engines, but there must be an additional external means of dissipating the heat absorbed by the engine during the power stroke.

(1) Air cooled. Air-cooled engines are used extensively in military vehicles as well as in aircraft. This type of engine is used where there must be an economy of space and weight. The cylinders are cooled by conducting the heat to metal fins on the outside of the cylinder wall and head. To effect the cooling, air is circulated between the fins. When possible, the engine is installed so that it is exposed to the airstream of the vehicle; the baffles direct the air to the fins. If the engine cannot be mounted in the airstream, a fan is employed to force the air through the baffles.

(2) Water cooled. Water-cooled engines require a water jacket to hold the coolant around the valve ports, combustion chambers, and cylinders; a radiator to dissipate the heat from the coolant to the surrounding air; and a pump to circulate the coolant through the engine. These engines also require a fan to pass air through the radiator because the speed of the vehicle does not always force enough air through the radiator to provide proper dissipation of heat.

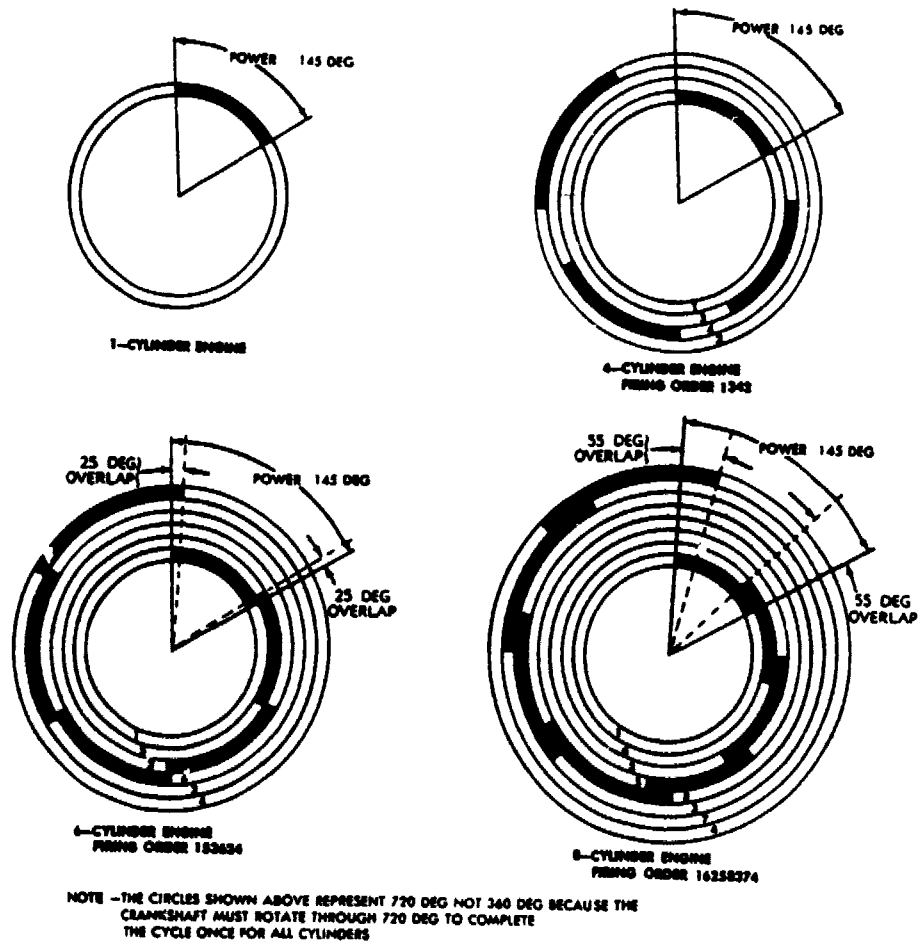

Figure 6. Power in 1-, 4-, 6-, and 8-cylinder engines.

c. Valve arrangement. Engines may be classified according to the position of the intake and exhaust valves; that is, whether they are in the cylinder block or in the cylinder head. Various arrangements have been used, but the most common are L-head, I-head, and F-head (fig 7). The letter designation is used because the shape of the combustion chamber resembles the form of the letter identifying it.

(1) L-head. In the L-head engine both valves are placed in the block on the same side of the cylinder. The valve operating mechanism is located directly below the valves, and one camshaft actuates both the intake and exhaust valves. This type has supplanted the T-head, in which both valves were in the block but on opposite sides of the cylinder. The disadvantage of the T-head was that it required two complete valve operating mechanisms.

(2) I-head. Engines using the I-head construction are commonly called valve-in-head or over-head-valve engines, because the valves are mounted in the cylinder head above the cylinder. This arrangement requires a tappet, push rod, and rocker arm above the cylinder to reverse the direction of valve movement, but only one camshaft is required for both valves. Some overhead valve engines make use of an overhead camshaft. This arrangement eliminates the long linkage between the camshaft and valve.

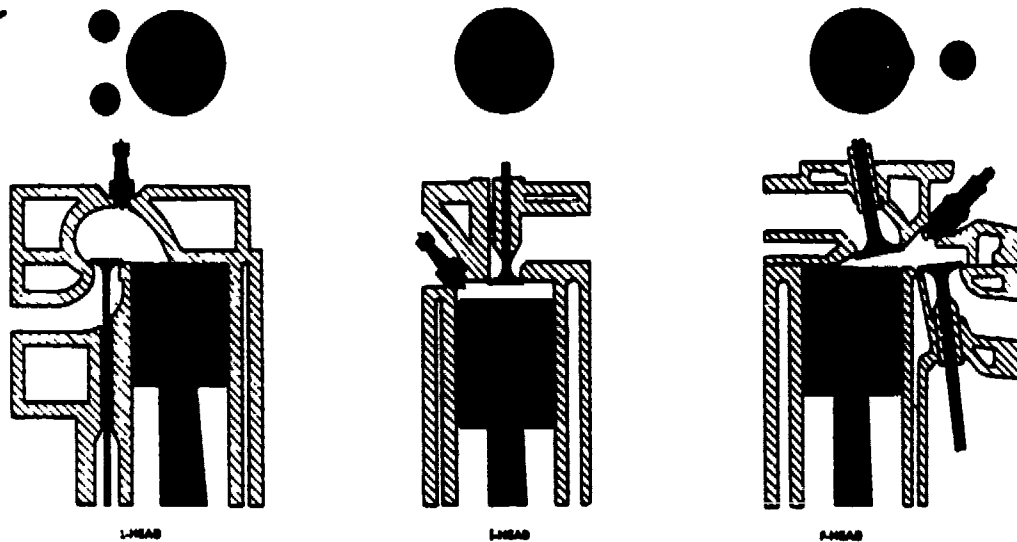

Figure 7. L-, I-, and F-head valve arrangements.

(3) F-head. In the F-head engine, the intake valves normally are located in the cylinder head, while the exhaust valves are located in the engine block. This arrangement combines, in effect, the L-head and the I-head valve arrangements. The valves in the head are actuated from the camshaft through tappets, push rods, and rocker arms (I-head arrangement), while the valves in the block are actuated directly from the camshaft by tappets (L-head arrangement).

d. Cylinder arrangement. Automotive engines also vary in the arrangement of cylinders in the block, depending on the engine use. Cylinder arrangement in liquid-cooled engines is usually in-line or is a V-type; in air-cooled engines, it is V-type, radial, or horizontal opposed.

(1) In-line. The vertical in-line cylinder arrangement is one of the most commonly used types. All the cylinders are cast or assembled in a straight line above a common crankshaft that is immediately below the cylinders. A variation is the inverted in-line type.

(2) V-type. In the V-type engine two "banks" of in-line cylinders are mounted in a V-shape above a common crankshaft. This type is designated by the number of degrees in the angle between the banks of cylinders. Usually, the angle of the V is 90° for 8-cylinder engines; 75° , 60° , or 45° for 12-cylinder engines; and 45° or 135° for 16-cylinder engines. Crankshafts for V-type engines generally have only half as many throws as there are cylinders, as two connecting rods (one for each bank) are connected to each throw.

(3) Horizontal opposed. The horizontal opposed engine has its cylinders laid on their sides in two rows; the crankshaft is in the center. Because of its low overall height, much less headroom is required for mounting the engine. It can be put under the body of a bus, for example, or it can be so mounted in a tank as to provide additional interior space in the tank. This engine is often called a pancake engine because it is relatively flat.

13

(4) Horizontal opposed with vertical crankshaft. In this engine, the cylinders are horizontal and opposed to each other, but the crankshaft is set vertically. This is the same type of engine mentioned in (3) above, except that the engine has been set up on end so that the crankshaft is vertical rather than horizontal.

8. ENGINE MEASUREMENTS.

a. Bore and stroke. The size of an engine can be indicated in terms of bore and stroke (fig 8). Bore is the diameter of the cylinder. Stroke is the distance that the piston moves in the cylinder, or the distance between top dead center and bottom dead center. When reference is made to these two measurements, the bore is always given first. For example, a 3-5/8 x 4 engine means that the cylinder bore, or diameter, is 3-5/8 inches and the length of the piston stroke is 4 inches.

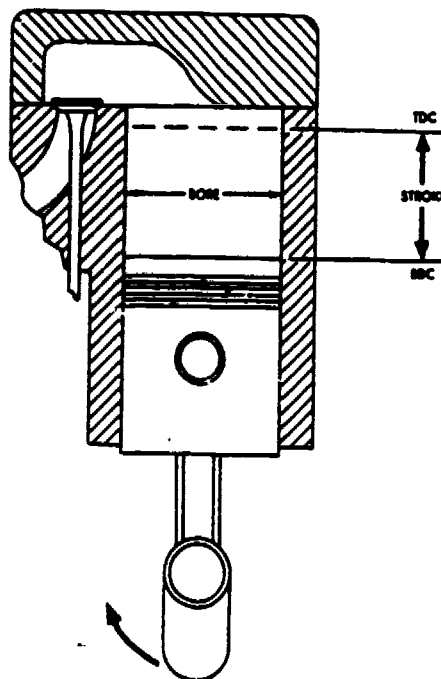

Figure 8. Bore and stroke of an engine cylinder.

b. Piston displacement. Piston displacement is the volume of space that the piston displaces as it moves from bottom dead center to top dead center. The volume is figured by multiplying the length of the stroke by the area of a circle having the diameter of the cylinder bore. Thus, a cylinder with a 3-5/8-inch diameter has an area of 10.32 square inches, and this times the stroke length of 4 inches equals 41.28 cubic inches.

c. Vacuum in cylinder on intake stroke. The piston, in moving down on the intake stroke, produces a partial vacuum in the cylinder. It is this vacuum that is responsible for air rushing in. A vacuum can be defined as an absence of air or other substances. It may be hard to think of air as a substance because it does not seem substantial, but it can be felt as a breeze or wind when it is moving.

14.

(1) Atmosphere. Air does have weight, as can be proven with a balance scale and two 1-cubic-foot containers (fig 9). If all air was drawn from one container so that it would be really empty (a vacuum), then it would weigh less than the other container. In fact, to balance the scales, 1-1/4 ounces would have to be placed on the empty container. At sea level, the weight of the air pressing downward on the ground produces a pressure of about 14.7 PSI.

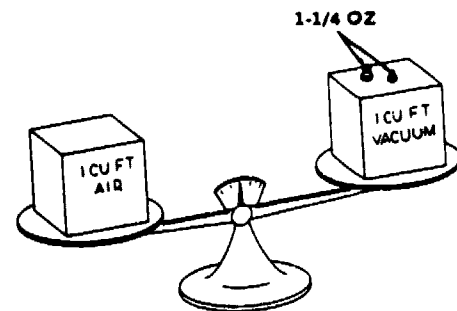

Figure 9. Illustrating the weight of air.

(2) Atmospheric pressure. The air surrounding the earth presses downward or exerts pressure. Ordinarily, this pressure is not noticed because we are accustomed to it. If the air was removed from a container and then the container was opened, this pressure would push air back into the container. This might be compared to what happens when an empty bottle is held under water and the cork is removed. The pressure of the water pushes water into the bottle. The higher we go into the air, the less pressure is found. Six miles above the earth, for example, the pressure is only about 4.4 PSI. Returning to earth, the air pressure increases; the nearer earth is approached, the greater the pressure of the air.

(3) Vacuum in the cylinder. When the piston starts to move downward in the cylinder on the intake stroke, it produces a vacuum in the cylinder. If both the intake and exhaust valves were closed, then no substance could enter to fill this vacuum and the cylinder would remain empty. However, at the same time that the piston starts to move down, the intake valve is opened. Now, atmospheric pressure pushes air past the intake valve and into the cylinder. The cylinder, therefore, becomes filled with air (or with fuel-air mixture in gasoline engines).

(4) Volumetric efficiency. Although the atmosphere exerts considerable pressure and rapidly forces air into the cylinder on the intake stroke, it does take time for the air to flow through the carburetor and past the intake valve. If given sufficient time, enough air will flow into the cylinder to "fill it up." However, the air is given very little time to do this. For example, when the engine is running at 1,200 RPM, the intake stroke lasts only 0.025 second. In this very brief period, all the air that could enter does not have time to flow into the cylinder as the intake stroke ends too quickly. Nevertheless, engine design has taken this factor into consideration so that good operation will result even at high engine speed.

(a) Measuring volumetric efficiency. The measure of the amount of fuel-air mixture that actually enters the cylinder is referred to in terms of volumetric efficiency. Volumetric efficiency is the ratio between the amount of fuel-air mixture that actually enters the cylinder and the amount that could enter under ideal conditions. The greater the volumetric efficiency, the greater the amount of fuel-air mixture entering the cylinder. The greater the amount of fuel-air mixture, the more power produced from the engine cylinder. At low speeds, more fuel-air mixture can get into the cylinder, thus the power produced during the power stroke is greater and volumetric efficiency is high. But at high speeds, the shorter time taken by the intake stroke reduces the amount of fuel-air mixture entering the cylinder, thus volumetric efficiency is lower. In addition, the air is heated as it passes through hot manifolds on its way to the cylinder and it expands. This further reduces the amount of fuel-air mixture entering the cylinder which, in turn, further reduces volumetric efficiency.

OS 607, 1-P12

(b) Increasing volumetric efficiency. Volumetric efficiency is higher at low engine speed because more fuel-air mixture gets into the cylinder. However, volumetric efficiency can also be improved by the use of a blower or air-compressing device. On gasoline engines, this device is called a supercharger. It raises the air pressure above atmospheric pressure so that the air is pushed harder on its way into the cylinder. The harder push, or higher pressure, insures that more air will enter the cylinder. In a supercharged engine, the volumetric efficiency can run well over 100 percent. Since 100 percent efficiency means that the pressure inside the cylinder equals atmospheric pressure, a volumetric efficiency of more than 100 percent means the pressure inside the cylinder would be greater than atmospheric pressure at the end of the intake stroke. This increased volumetric efficiency increases the engine power output. A supercharger is very important on airplane engines because the lowered air pressure (about 4.4 PSI at a height of 6 miles) must be greatly increased if engine power output is to be maintained at high altitudes.

d. Compression ratio.

(1) General. The compression ratio of an engine (fig 10) is the volume in one cylinder with the piston at bottom dead center (displacement volume plus clearance volume) divided by the volume with the piston at top dead center (clearance volume). This figure indicates the actual amount that air drawn into the cylinder will be compressed. For example, suppose that an engine cylinder has an air volume of 63 cubic inches with the piston at bottom dead center and a volume of 10 inches with the piston at top dead center. This gives a compression ratio of 63 divided by 10 or 6.3:1. That is, the air is compressed from 63 to 10 cubic inches, or to 1/6.3 of its original volume, on the compression stroke.

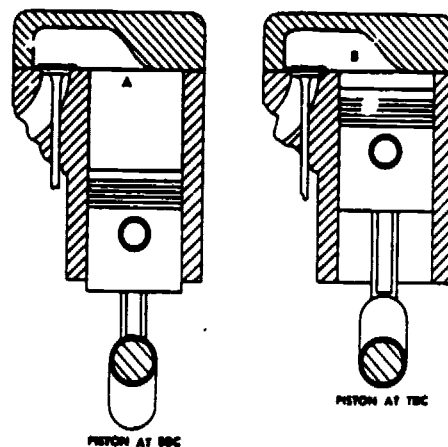

Figure 10. Compression ratio is ratio between "A" and "B".

(2) Effect of increasing compression ratio. As the compression ratio is increased, the fuel-air mixture drawn into the cylinder is compressed into a smaller space. This means a higher initial pressure at the start of the power stroke. It also means that the burning gases can expand a greater amount. Thus, there are higher pressures for a longer period on the power stroke, and more power is obtained with each power stroke. Therefore, increasing the compression ratio increases the power output of an engine. Racing car builders machine-off cylinder heads to reduce the volume of the combustion chambers, thereby increasing compression ratios. By this one act, the power output of an engine can be increased several horsepower. One important problem brought about by increasing compression ratios is to find a fuel that will not cause difficulty from detonation.

9. ENGINE TIMING. In a gasoline engine, the valves must open and close at the proper time with regard to the piston position and stroke. In addition, the ignition system must produce sparks at the spark plugs at the proper time so that the power strokes can start. Both valve and ignition system action must be properly timed if good engine performance is to be obtained.

16

a. Valve timing. A new mixture must be trapped in the cylinder at the proper time during each cycle and, after combustion, the exhaust gases must be allowed to flow out of the cylinder. This means that the intake and exhaust valves must open and close in step with the piston movement. The opening and closing of the valves is controlled by the camshaft. The position of the piston is related to the position of the crankshaft, since they are connected by the connecting rod. Thus, the crankshaft and camshaft must be in the proper relationship for correct valve timing. Figure 1 shows one method of driving the camshaft--a gear on the crankshaft drives a gear on the camshaft. The camshaft turns once for every two crankshaft revolutions. As long as the relationship between the gears is not changed, the timing of the valve action will be in correct relationship to the piston movement. Figure 11 illustrates a valve timing diagram on one engine. Valve timing varies for different engines.

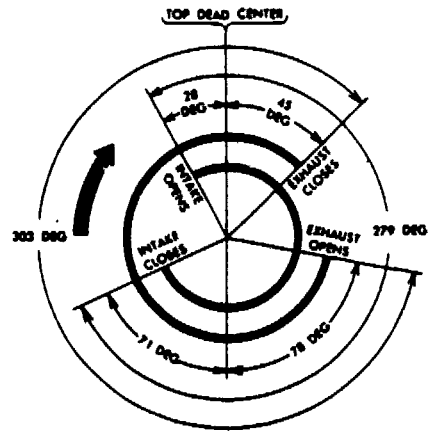

Figure 11. Valve timing diagram on one engine.

b. Exhaust valve timing. The exhaust valve opens before the piston reaches the end of the power stroke so that the pressure remaining in the cylinder will cause the exhaust gases to start rushing from the cylinder. If the valve did not open until the end of the power stroke, then there would be pressure in the cylinder at the start of the exhaust stroke that would impede the upward piston movement. Opening the exhaust valve before bottom dead center on the power stroke is reached causes some loss of pressure on the piston at the end of the power stroke. However, it does insure better removal of the burned gases which, plus the reduced pressure on the piston at the start of the exhaust stroke, more than balances this small loss.

c. Rock positions. When the piston is at top dead center the crankshaft can move 150 to 200 without causing the piston to move up or down any perceptible distance. This is one of the two rock positions (fig 12). When the piston moves up on the exhaust stroke, considerable momentum is imparted to the exhaust gases as they pass out through the exhaust valve port, but if the exhaust valve closes at top dead center a small amount of the gases will be diluted. Since the piston has little downward movement while in the rock position, the exhaust valve can remain open during this period and thereby permit a more complete scavenging of the exhaust gases.

d. Intake valve timing. Very little vacuum is produced in the cylinder as the piston passes through the rock position at top dead center. The exhaust gases, however, because of their momentum in passing through the exhaust valve port, produce an air current in the chamber. This air current is sufficient to cause a new mixture to start moving into the cylinder if the intake valve is open. For this reason, the intake valve is opened slightly before the piston reaches top dead center. As the piston goes down on the intake stroke, the rapid decrease in pressure in the cylinder enables atmospheric pressure to impart considerable momentum to the incoming mixture. If the piston were to move slowly, the mixture would be able to enter fast enough to keep the pressure in the cylinder equal to that outside. But, ordinarily, the piston will be moving so fast that it will reach the end of

17
its downward stroke before a complete charge has had time to enter; that is, the pressure in the cylinder will be below that of the atmosphere. The intake valve, therefore, remains open a number of additional degrees of crankshaft rotation past bottom dead center (or through the lower rock position). This allows additional time for the fuel-air mixture to flow into the cylinder.

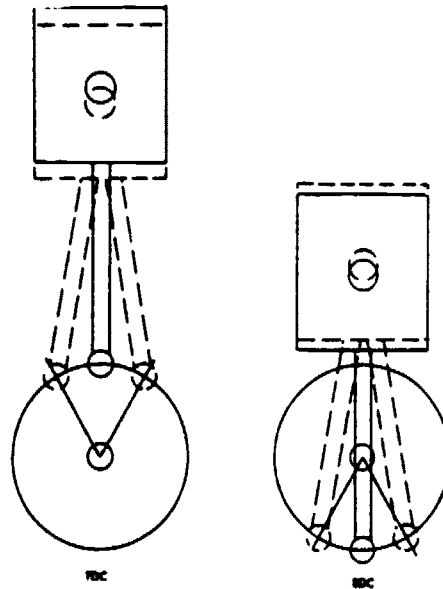

Figure 12. Rock positions.

e. Ignition timing. Ignition timing refers to the timing of the spark at the spark plug gap with relation to the piston position during the compression and power strokes. Even though the compressed fuel-air mixture burns very rapidly, almost explosively, it does take some time for the mixture to burn and for the pressure increase from combustion to take place. Therefore, it is common for the ignition system to be so timed that the spark occurs before the piston reaches top dead center on the compression stroke. This gives the mixture sufficient time to ignite and start burning. If this time were not provided, that is, if the spark occurred at or after top dead center, then the pressure increase would not keep pace with the piston movement. The piston would be moving down on the power stroke as the mixture started to burn. The pressure, therefore, would not go very high and power would be lost. This power loss is avoided by timing the spark to occur before top dead center.

f. Ignition advance. At the higher speeds, there is still less time for the fuel-air mixture to ignite and burn. To compensate for this, thereby avoiding power loss, the ignition system includes an advance mechanism that functions on speed. As engine speed increases, the advance mechanism causes the spark to occur earlier in the cycle. Thus, at high speed, the spark may occur as much as 30° before top dead center on the compression stroke. This means that the fuel-air mixture is ignited and starts to burn well before the power stroke actually starts. However, the piston is up over top dead center and moving down on the power stroke before the pressure rises to any great extent. This extra time gives the mixture ample time to burn well and deliver maximum push to the downward moving piston. On most distributors, there is also a vacuum-advance mechanism that functions on intake-manifold

18

vacuum. At part throttle, there is a partial vacuum in the intake manifold and less fuel-air mixture getting into the cylinder. With less fuel-air mixture, the mixture is less highly compressed and burns more slowly. Therefore, the vacuum-advance mechanism provides a spark advance that gives the mixture ample time to burn and increase pressure in the cylinder in the early part of the power stroke.

10. ENGINE OUTPUT. Engines vary in size and output. When comparing engines, compare not only their size but also the work they can do.

a. Work. Work is the movement of a body against an opposing force. When a weight is lifted from the ground, work is done on the weight. It is moved upward against the force of gravity. When a tank pushes over a tree, it does work on the tree as it forces it to the ground. If a 1-pound weight is lifted 1 foot, 1 foot-pound of work is done.

b. Energy. Energy is the ability to do work. As the speed of a tank is increased, the energy of movement of the tank is also increased, and it can knock over a tree more easily. The higher a weight is lifted from the ground, the more energy is stored in the weight. Then, when it falls, it will strike the ground harder; that is, it will do more work on the ground. If a stake is being driven into the ground, the greater the distance the hammer falls, the more work it does on the stake and the further it drives it into the ground.

c. Power. Power is the rate of work. It takes more power to work fast than to work slowly. Engines are rated in terms of the amount of work they can do per minute. A large engine that can do more work per minute is more powerful than a small engine that cannot work so hard. The work capacity of engines is measured in horsepower, which is a definite amount of power. Actually, it is the amount of power that an average horse was found to develop when working hard in tests made many years ago at the time steam engines were being developed. It was found that an average horse would lift a weight of 200 pounds a distance of 165 feet in 1 minute. The amount of work involved here is 33,000 foot-pounds (165 times 200). If 100 pounds were lifted 330 feet or if 330 pounds were lifted 100 feet, the amount of work would be the same, 33,000 foot-pounds. When this amount of work is done in 1 minute, then 1 horsepower is required. If it took 2 minutes to do this amount of work, then 16,500 foot-pounds per minute, or 1/2 HP, would be required. Or, if 33,000 foot-pounds of work were done in 1/2 minute, then 66,000 foot-pounds per minute or 2 HP would be required.

d. Prony brake. A prony brake may be used to measure the actual horsepower that an engine can deliver. This device usually makes use of a series of wooden blocks fitted around a special flywheel that is driven by the engine (fig 13). A tightening device is arranged so that the blocks can be tightened on the flywheel. In addition, an arm is attached to this tightening device and one end of the arm rests on a scale. In operation, the wooden blocks are tightened on the flywheel. This loads up the engine and works it harder. Also, the pressure on the blocks tends to cause the arm to turn so that force is exerted on the scale. The length of the arm times the force exerted on the scales gives the engine torque in pound-feet. The results of the prony brake test can be converted into brake horsepower by using the formula

$$\text{BHP} = \frac{2\pi l n w}{33,000}$$

where l is the length of the arm in feet, n is the speed in RPM, and w is the load in pounds on the scale. For example, the arm is 3 feet long, the load on the scale is 50 pounds, and the speed is 1,000 RPM, or:

$$\text{BHP} = \frac{2 \times 3.1416 \times 3 \times 1,000 \times 50}{33,000} = 28.56 \text{ brake horsepower.}$$

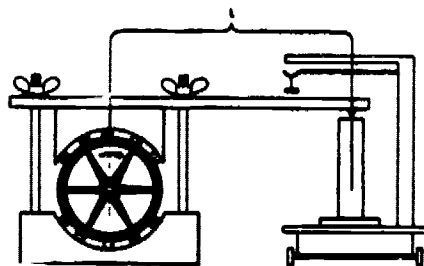

Figure 13. Simplified drawing of a prony brake.

e. **Dynamometer.** The dynamometer is essentially a dynamo of a special type that can be driven by an engine. This special dynamo can absorb all the power the engine can produce and indicate this power on dials or gages. Although the dynamometer is more complicated than a prony brake, it is generally considered to be more flexible and accurate. In addition to measuring engine output, the dynamometer can also be used to drive the engine for purposes of measuring the friction of the engine itself or of the various accessories.

f. **Torque effect.**

(1) Torque is twisting or turning effort. When the lid on a jar is loosened, a twisting force or torque is applied to it (fig 14). Torque is measured in pound-feet (not to be confused with work which is measured in foot-pounds). For instance, suppose a wrench is used to tighten a nut on a stud (fig 15). If the handle of the wrench were 1-foot long and a 10-pound force put on its end, then 10 pound-feet of torque would be applied on the nut. If the handle were 2 feet long and a 10-pound force put on its end, 20 pound-feet of torque would be applied. Torque can be converted into work by using the formula

$$\text{ft-lb (work)} = 2 \pi n \times \text{lb-ft (torque)} = 6.2832 n \times \text{lb-ft.}$$

where n is the speed in revolutions per minute. For example, if an engine were checked on a prony brake and found to be delivering 100 pound-feet torque at 1,000 RPM, then it would be doing 628,320 foot-pounds of work every minute. This can be converted into horsepower by dividing it by 33,000.

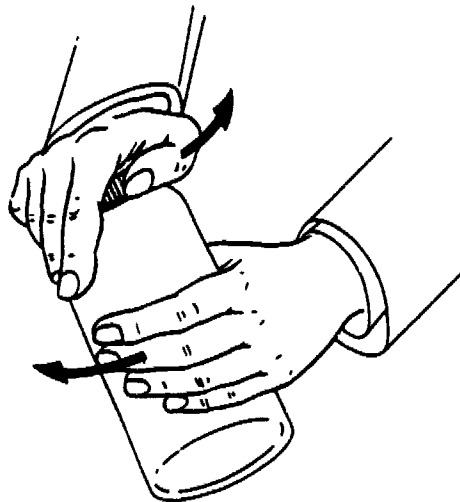

Figure 14. Applying twisting effort, or torque, on can lid.

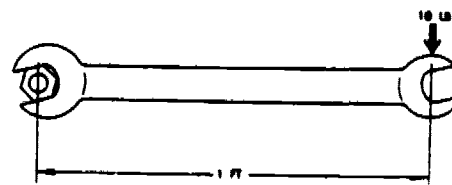

Figure 15. Applying torque with a wrench on a nut.

(2) The engine exerts torque through gears and shafts connected to the wheels so that the wheels turn and the vehicle moves. The amount of torque that an engine produces varies with engine speed (fig 16). Note that torque increases and then, at an intermediate speed, falls off. The reason for this variation is, that with increasing speed, the engine is turning faster and is capable of supplying a greater twisting effort or torque. However, with further speed increases, volumetric efficiency falls off, less fuel-air mixture gets to the cylinders on each intake stroke, the power strokes are not as powerful, and the torque falls off.

g. Torque-horsepower-speed (RPM) relationship.

(1) Figure 17 shows the comparison between the horsepower and torque of an engine. Torque increases with speed (up to rated speed) as shown in figure 16. Horsepower also shows a change with speed, which is more marked than with torque. Horsepower is directly related to both torque and to speed. When both torque and speed are on the increase, as in the speed range of 1,200 to 1,600 RPM, then horsepower goes up sharply. After torque reaches maximum and begins to drop off, the horsepower continues to climb to its maximum before it starts to curve. Finally, in the higher speed ranges, where torque falls off sharply, horsepower also falls off. The horsepower formula

$$(HP = \frac{2\pi lw}{33,000})$$

shows that horsepower depends on both speed and torque, since torque equals lw and n is speed. Substituting in the formula and dividing 2π (or 6.2832) into 33,000 gives

$$HP = \frac{\text{torque} \times \text{RPM}}{5,252},$$

which shows the relationship between horsepower, torque, and speed more directly.

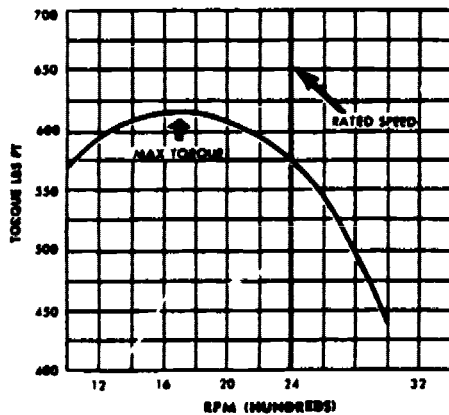

Figure 16. Relationship between torque and speed.

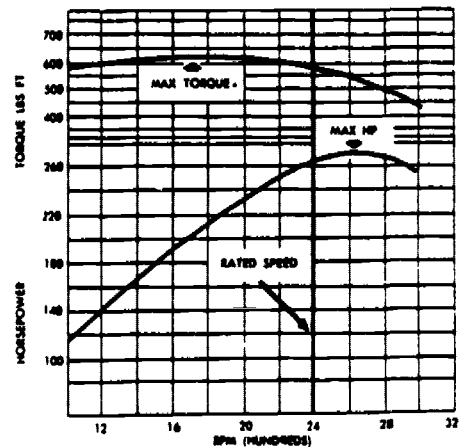

Figure 17. Relationship between torque and horsepower.

21

(2) A rated speed is indicated in figures 16 and 17. This is the speed at which the governor is usually set in military vehicles. The rated speed is selected because, at higher engine speeds, wear on the engine increases rapidly and a disproportionate amount of fuel is used. Overspeeding, or driving the engine above rated speed, allows but a slight increase of horsepower.

h. Gross and net horsepower. The gross horsepower of an engine is that amount of power the engine delivers after it has been stripped of the muffler, fan, generator, pump, and other accessories that require power to operate. Net horsepower is the power available at the flywheel after the accessories have detracted from the gross horsepower.

i. Indicated horsepower. This is the horsepower actually developed inside the engine cylinders. It is called indicated horsepower because an indicating device is required to measure it. This device measures the pressures developed in the engine cylinders and, by a series of steps, translates the data into indicated horsepower. The indicated horsepower is always considerably greater than horsepower delivered by the engine, since power is lost from the engine in a number of ways (friction, heat-loss, etc).

j. SAE horsepower. The Society of Automotive Engineers (SAE) developed a simplified method of calculating horsepower as based on engine dimensions. This rating was used only for commercial licensing of vehicles. The formula is

$HP = \frac{D^2 N}{2.5}$, where D is the cylinder diameter and N is the number of cylinders.

11. ENGINE EFFICIENCY.

a. Efficiency. Engine efficiency is the relationship between results obtained and the effort required to obtain those results. It is expressed as: $\text{efficiency} = \frac{\text{output}}{\text{input}}$. As an example, if a set of pulleys were used to raise a 450-pound weight 2 feet and it required a 100-pound pull for 10 feet (fig 18), it would take 1,000 foot-pounds to get out 900 foot-pounds. The ratio would be $\frac{900}{1,000}$ or 0.90. In other words, the efficiency of the pulleys would be 90 percent, so there was a loss of 10 percent of the work put in. This system of pulleys shows a loss (or is only 90 percent efficient) because of friction. No machine or engine is 100 percent efficient--all lose energy.

b. Friction loss. Friction is a source of energy loss in any mechanical system. If a heavy plank is dragged across a rough floor, it offers some resistance to the movement. This resistance to movement would be less if the plank and floor were polished smooth. Resistance would be still less if the plank floated in water. Such resistance to movement is called friction. Friction can be visualized as being caused by tiny irregularities or high points on the surfaces of moving objects. These catch on each other and particles are torn off. All of this requires force to overcome. If the plank and floor are made smooth, then the projecting points are much smaller and have less tendency to catch and tear off. Therefore, less force is required to pull the plank across the floor. If the plank is floated in water, the surfaces can no longer rub against each other; however, there is still some friction in the liquid. In the engine, friction occurs at all moving parts even though the parts are, in effect, floated in films of oil.

c. Mechanical efficiency. The mechanical efficiency of the engine is the relationship between the power produced in the engine cylinders (indicated horsepower) and the power delivered by the engine (brake horsepower). Internal engine losses from friction and other factors always prevent brake

OS 607, 1-P19

22

horsepower from equaling indicated horsepower. A typical engine, for example, might develop 200 indicated horsepower as against an actual brake horsepower of 180. This engine would have a mechanical efficiency of:

$$\frac{\text{Brake horsepower}}{\text{Indicated horsepower}} = \frac{180}{200} = 90 \text{ percent.}$$

d. Thermal efficiency.

(1) Thermal efficiency is the relationship between the heat energy in the fuel and the engine power output (thermal means of or pertaining to heat). The term thermal efficiency relates the heat energy of the fuel and the work output. The heat energy is the amount of heat the fuel will produce as it burns. Much of this heat is lost to the cylinder walls and cooling system. Still more is lost in the hot exhaust gases as they pass out of the cylinder. This heat that is lost cannot do anything to cause the engine to produce power. Therefore, only a relatively small part of the heat in the burning fuel can contribute anything toward pushing down on the pistons and causing the engine to produce power. In actual practice, because of the great amount of heat lost to the cooling water, lubricating oil, and in the exhaust gases, thermal efficiency may be as low as 20 percent. In other words, as much as 80 percent of the energy in the fuel is lost. However, the remaining 20 percent is sufficient to operate the engine normally. Practical limitations prevent thermal efficiencies of much above 25 percent.

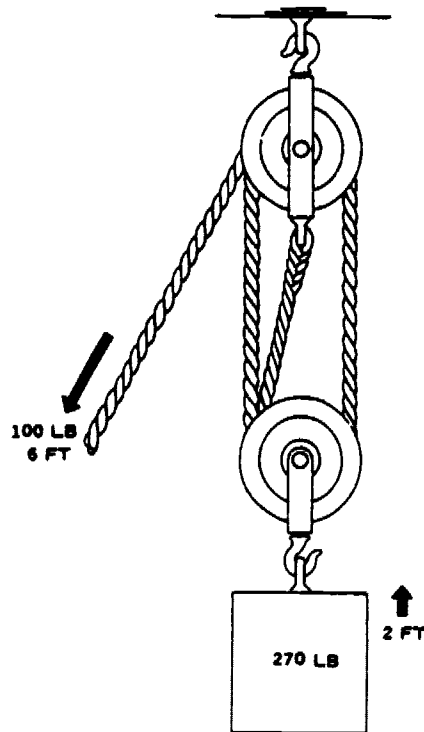

Figure 18. System of pulleys in which 1,000 foot-pounds must be expended to realize 900 foot-pounds of work.

OS 607, 1-P20

(2) The relationship between the fuel input and the power output is commonly expressed in heat units called British thermal units (BTU). One BTU is equal to 778 ft-lb of work; therefore, the horsepower output of an engine can be readily converted into BTU per unit of time. The sources of power in an engine is fuel, and the BTU content of regularly used fuels has been determined by laboratory analysis as:

$$\text{Thermal efficiency} = \frac{\text{Power output in BTU}}{\text{fuel input in BTU}}$$

Example. - An engine delivers 85 BHP for a period of 1 hour and in that time consumes 50 pounds (approx 7-1/2 gals) of gasoline. Assuming that the gasoline has a value of 18,800 BTU per pound, we find the thermal efficiency of the engine to be:

Power delivered by the engine is 85 BHP for 1 hour, or 85 HP-hours,

$$1 \text{ HP-hour} = \frac{33,000 \text{ ft-lb per min} \times 60 \text{ min}}{778 \text{ ft-lb per BTU}} = 2,545 \text{ BTU}$$

$$\begin{aligned} 85 \text{ BHP} \times 2,545 \text{ BTU} &= 216,325 \text{ BTU output} \\ 50 \text{ lb} \times 18,800 \text{ BTU per lb} &= 940,000 \text{ BTU input per hour} \end{aligned}$$

$$\text{Overall thermal efficiency} = \frac{216,325}{940,000} = 0.230, \text{ or } 23 \text{ percent.}$$

EXERCISE

1. Which component of an internal combustion engine moves in both a reciprocating and a rotary motion?
 - a. Crankshaft
 - b. Connecting rod
 - c. Camshaft
2. At what piston position of a gasoline engine are the intake and exhaust valves both closed?
 - a. Bottom of the power stroke
 - b. Top of the exhaust stroke
 - c. Top of the compression stroke
3. How many power strokes will be made in a 4-cylinder, 4-stroke-cycle engine if the crankshaft completes 1,000 revolutions?
 - a. 500
 - b. 1,000
 - c. 2,000
4. What is the stroke sequence of a 4-stroke-cycle gasoline engine?
 - a. Intake, power, compression, and exhaust
 - b. Compression, exhaust, intake, and power
 - c. Intake, compression, power, and exhaust
5. What is the MOST common method of engine classification?
 - a. Number of cylinders
 - b. Cylinder arrangement
 - c. Type of fuel used

24

6. Which type engine is often referred to as a "pancake" engine?
 - a. Horizontal opposed
 - b. V-type
 - c. In-line

7. How many rock positions are contained in each complete crankshaft revolution of a 1-cylinder engine?
 - a. 1
 - b. 2
 - c. 3

8. What is power?
 - a. Measurement of energy
 - b. Movement of a body
 - c. Rate of work

9. What measurement of engine performance exhibits the greatest marked change with an increase in engine RPM?
 - a. Horsepower
 - b. Thermal efficiency
 - c. Rated speed

10. What TWO values are required to determine the mechanical efficiency of an engine?
 - a. Gross and net horsepower
 - b. Thermal and volumetric efficiency
 - c. Brake and indicated horsepower

CORRESPONDENCE COURSE
of the
US ARMY ORDNANCE
CENTER AND SCHOOL



LESSON ASSIGNMENT SHEET

- Ordnance Subcourse No 607. Engine Principles
- Lesson 2 Spark Ignition Engines
- Credit Hours Two
- Lesson Objective After studying this lesson you will be able to describe the construction of a typical spark ignition engine.
- Text Attached Memorandum
- Materials Required Answer sheet and exercise response list
- Suggestions. While reading the attached memorandum study all accompanying illustrations.

STUDY GUIDE AND ATTACHED MEMORANDUM

1. GENERAL. This lesson discusses the basic components of engines. Because many of the parts of in-line, horizontal-opposed, and V-type engines are similar, they may be described together. The cooling and lubrication systems and their component parts are described in later lessons.

2. CYLINDER BLOCK, LIQUID-COOLED ENGINE.

a. Cylinder blocks are used only in liquid-cooled engines, whether they are in-line, horizontal-opposed, or V-type. These blocks were formerly made of gray cast iron, but the wearing qualities of this metal were not adequate. The material now used in cylinder blocks is a special iron alloy containing nickel, chromium, and molybdenum. The cylinder block of an engine contains the cylinders in which the pistons move, the valve ports (in L-head engine), and the passages through which the coolant flows. It also forms the upper part of the crankcase and, as such, acts as the base of the engine (fig 1).

b. The cylinders and crankcase are cast en bloc; that is, in one piece called the cylinder block. The advantages of the en bloc method are so many that it has become almost universal. Casting cylinders en bloc produce more compact, shorter, and more rigid construction at less cost than casting cylinders singly or in pairs. The assembly is simplified and valve-operating mechanisms are easier to enclose.

c. The cylinders of a liquid-cooled engine are surrounded by jackets through which the liquid circulates. These jackets are cast integrally with the cylinder block. Commur cating passages permit the coolant to circulate around the cylinders and through the head.

OS 607, 2-P1
December 1975

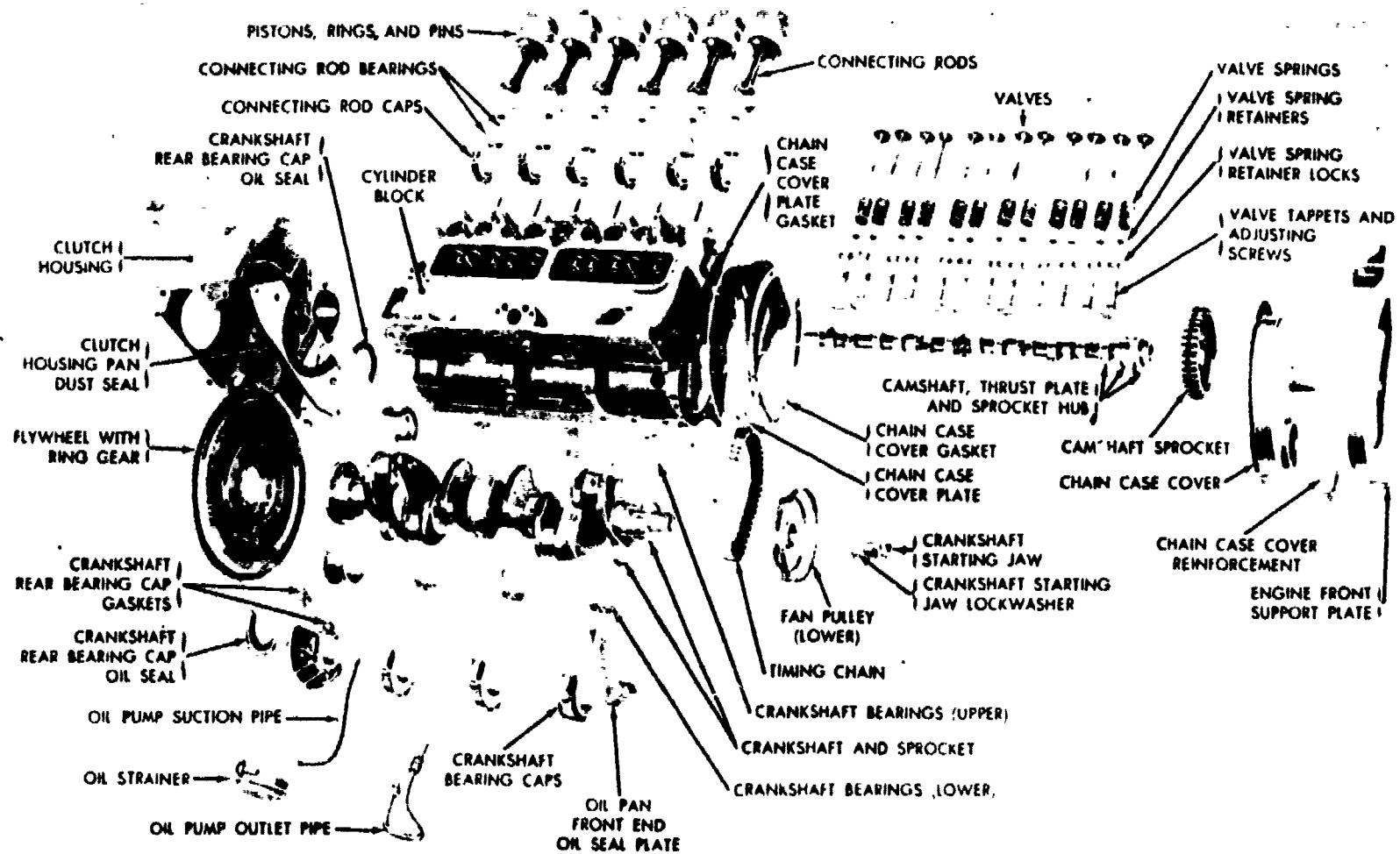

Figure 1. Cylinder block and component of a 6-cylinder, L-head, in-line, liquid-cooled engine.

d. The cylinders must be absolutely round and true and their surfaces must be highly finished. These surfaces are obtained in manufacturing by boring, grinding, and/or honing (in that order), and the final result is a precision finish that offers little friction and assures a uniform seal between the cylinder and piston rings.

e. Cylinder liners, or sleeves, are becoming more common in large motor-vehicle engines. Liners are of two types and are made of alloys specially treated to give better wearing qualities. The wet-type liner comes in direct contact with the coolant and is sealed at the top and bottom by a rubber sealing ring; the dry-type liner (fig 2) does not contact the coolant directly. Liners have two advantages: they usually wear longer and, after they have been worn beyond the maximum oversize, can be easily replaced, thus avoiding replacement of the entire block.

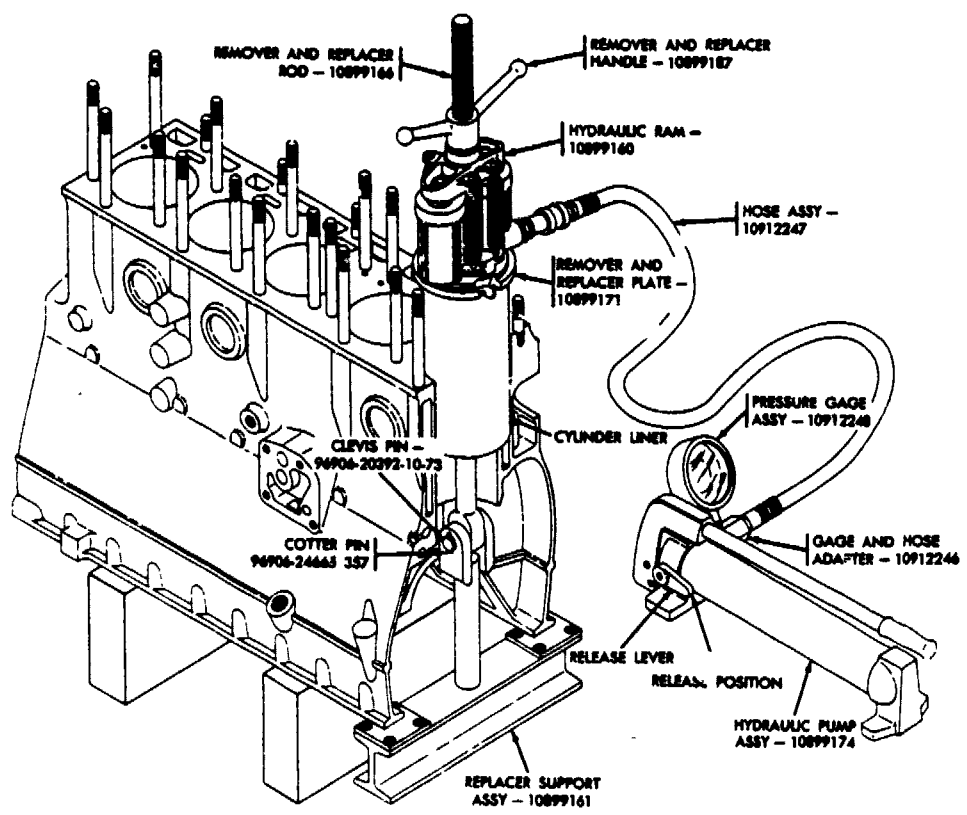
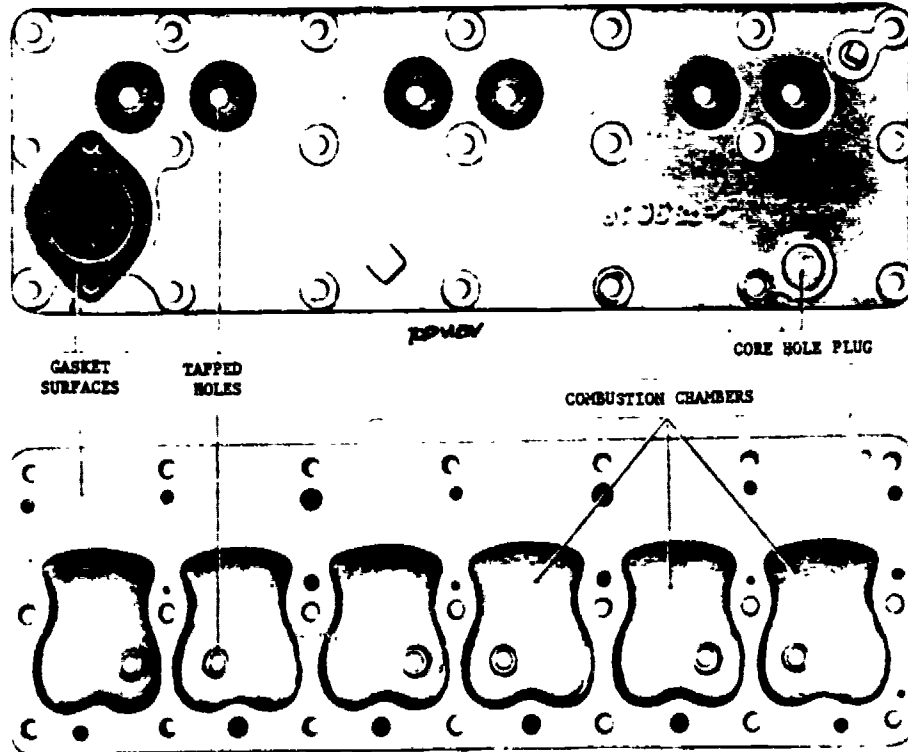

Figure 2. Cylinder sleeve remover and replacer kit.

3. CYLINDER HEAD. In liquid-cooled engines, the cylinder head (fig 3), a separate casting that contains the combustion chambers, is bolted to the top of the cylinder block to close the upper ends of the cylinders. It contains passages which match those of the cylinder block and allow the coolant to circulate in the head. It has tapped holes in the combustion chambers into which the spark plugs are screwed. To retain compression in the cylinder, a metal or metal-asbestos cylinder head gasket is placed between the head and the block. Holes are cut in this gasket for the bolts



or studs holding the cylinder head to the block, for the passage of coolant from the block to the head, and for the combustion chambers. The cylinder heads of overhead valve engines also contain and support the valves, valve rocker arms, and rocker arm shaft (fig 4). All cylinder heads were formerly made of cast iron, but many engines are now being built with cylinder heads of cast aluminum alloy because this material is a better conductor of heat and there is less tendency for localized hot spots to develop. The aluminum alloy is light in weight and has a very favorable ratio of weight to strength at high temperatures.



cooled engine.

4. CYLINDER AIR-COOLED ENGINES (FIG 5).

a. **Crankcase.** The crankcase is a simple and rugged one-piece cast aluminum structure with forged aluminum main bearing caps. The contours of the crankcase are smooth and without ribs of any kind. Short and straight stress paths are provided through the design of the main bearing caps, which function as an integral part of the crankcase. Each main bearing cap is secured with four cap bolts and two through-bolts that clamp the main bearing caps in the tunnel slot of the main bearing support web in the crankcase. This type of crankcase and bearing cap construction and the use of many highly flexible bolts assure good stress distribution and uniform distribution of the combustion forces over the entire crankcase. The two through-bolts for each main bearing cap tie the two crankcase sidewalls together. The crankcase extends far below the crankshaft centerline and the cast aluminum oil pan is made a part of the structure. Thus, a stiff beam member is obtained that compensates for the small total crankcase height, which is characteristic for air-cooled engines.

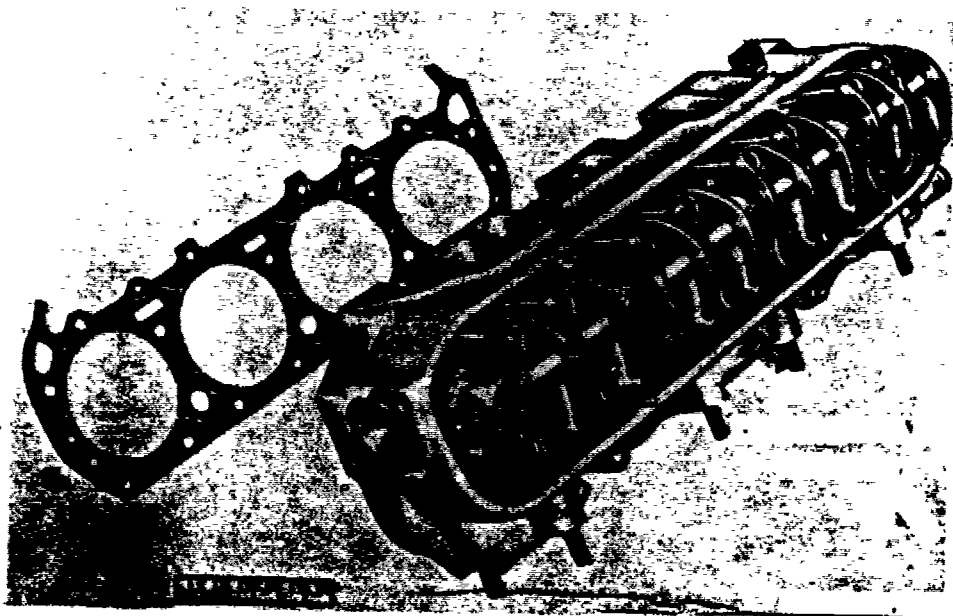

Figure 4. Overhead valve cylinder head and associated parts.

b. Crankshaft and bearings (fig 6). The crankshaft assembly is a nitrided steel forging with 7 main bearing journals and 6 crankpins, 12 counterweights, a flange on the rear end for mounting the flywheel, and a flange on the front end for mounting a torsional vibration damper. The integrally forged crankshaft counterweights provide for approximately 85 percent of crankshaft balance. The crankshaft main bearing journal size is 4.25 inches and the crankpin size is 3.75 inches. The width of the cheek is 1.6 inches. The anticipated high output ratings demand the use of peak combustion pressure between 1,600 and 1,800 PSI; therefore, the crankshaft must have torsional rigidity and bending rigidity. The internal forces trying to break the engine in the middle are reduced by the integrally forged crankshaft counterweights. The bearings are copper-lead in both main and connecting rods and are backed with rather heavy steel shells, 0.250-inch thick, in the case of the main bearings. The main bearings have a width of 2 inches, and the connecting rod bearing 1.35 inches. Each crankpin accommodates two opposing connecting rod assemblies. All crankpin and main bearing journals are hollow to reduce weight. Holes are drilled diagonally through each main bearing journal and extend through the crank cheek and crankpin to provide a direct passage for oil under pressure to the connecting rod and crankshaft main bearings. The crankshaft and flywheel are statically and dynamically balanced. The torsional vibration damper is a precision-made viscous-type and is replaceable only as an assembly.

c. Connecting rods and bearings (fig 7). The connecting rod assemblies are of conventional design and are tapered, I-beam section steel forgings. The length from center to center is 11 inches; the piston pin diameter is 2 inches. The piston pin bushing at the small end of the connecting rod is a bronze-lined, steel-backed, split-type bearing, pressed into the piston pin end of the connecting rod, and is diamond bored. The big end of the connecting rod, which connects to the crankshaft crankpin, has a replaceable precision connecting rod bearing, which is a steel-backed, split-type, having a copper-lead alloy bearing surface.

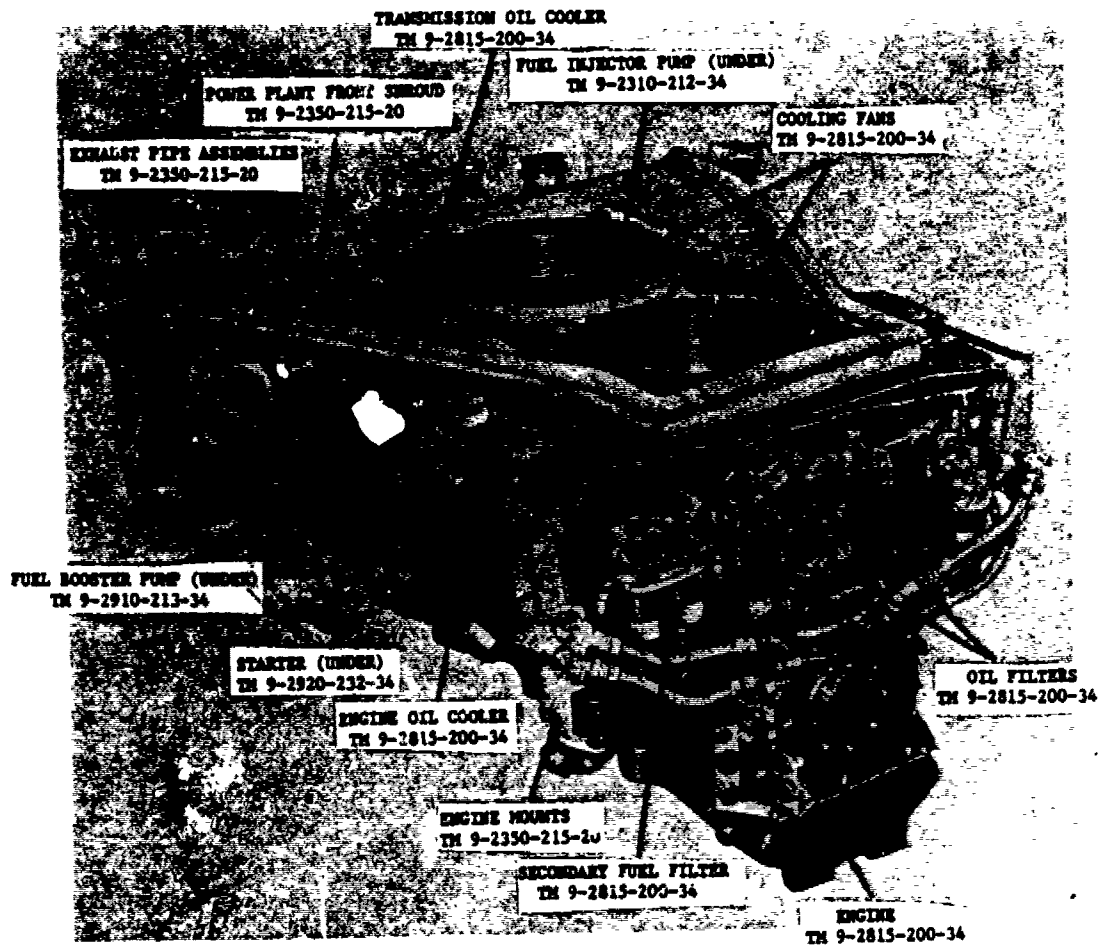

Figure 5. 12-cylinder engine AVDS.

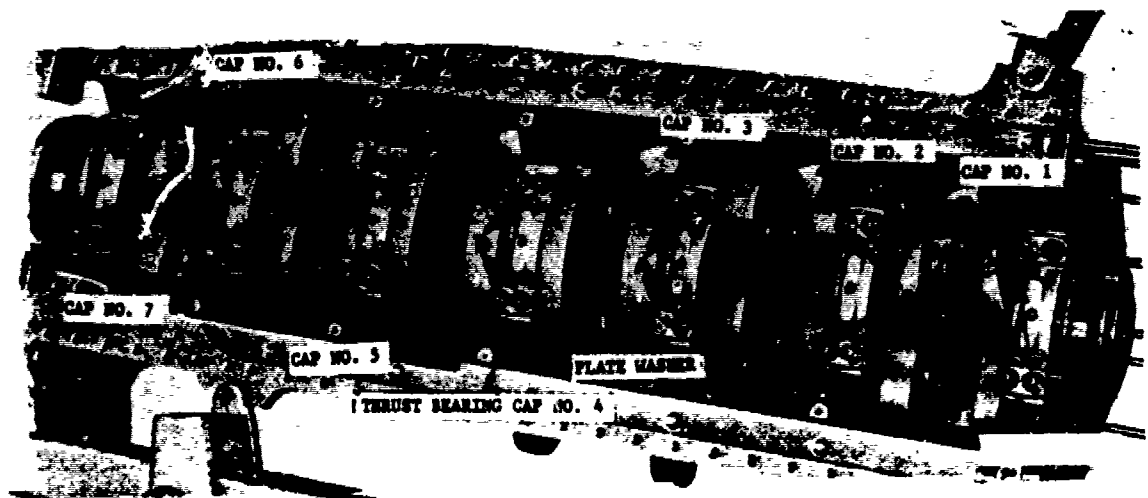

Figure 6. Crankcase AVDS-1790-2 engine.

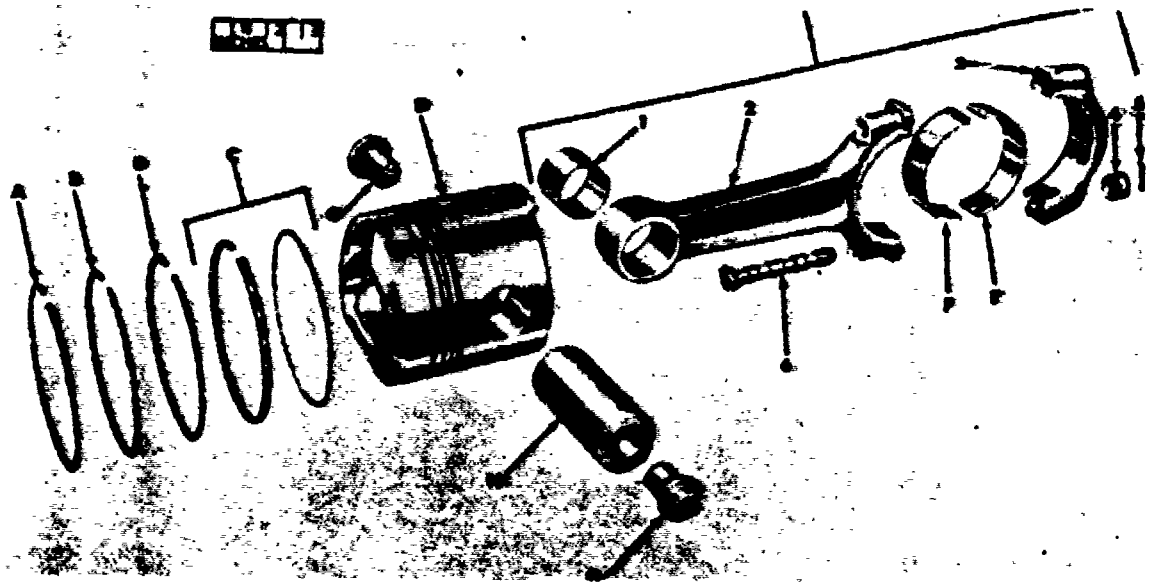

Figure 7. Piston and connecting rod--exploded view.

d. Pistons, pins, and rings (fig 7).

(1) Pistons and pins.

(a) The pistons are aluminum forgings, cam ground and tapered to provide an accurate fit at operating temperatures. The piston dome is machined to the shape of a conical section (toroidal-shape) so that it tapers into the open-type combustion chamber. The piston is oil-cooled by an oil jet mounted in the crankcase. A separate oil system is built into the engine which will be described in detail later.

(b) The heavy walled, tubular, steel piston pins are full-floating in the piston and connecting rod. Domed aluminum plugs are inserted into each end of the piston pin to center it in the piston and prevent scoring of the cylinder wall.

(2) Piston rings. Each piston is fitted with four rings. The upper three rings are compression rings and the bottom ring is an oil control ring. All rings are chrome plated for more wear resistance. A 15° included angle keystone top ring is used, along with two taper-faced compression rings and a dual edge conformable oil scraper ring. Basic ring thickness is 0.090-inch which provides maximum bore conformability and minimum ring groove wear without any evidence of ring flutter at high speed.

OS 607, 2-P7

e. Cylinders and valves (fig 8).

(1) Each cylinder assembly is an individually replaceable unit that consists of a barrel, cooling fin muff, and a cylinder head. The cylinder barrel is made of steel. The cooling fin muff is an aluminum casting and is cast directly on the steel cylinder barrel. A mounting flange is machined on the cylinder barrel near the base to provide an attachment for the cylinder to the crankcase. The cylinder assembly is secured to the crankcase with studs and nuts. The cylinder head is a casting of aluminum alloy with high temperature characteristics. The finned, cast aluminum cylinder head is threaded and is screwed and shrunk onto the cylinder barrel while the cylinder head is heated. The main features of the cylinder head design are overhead camshaft, two angled valves, a simple cooling fin design, and an injection nozzle installation with a high degree of accessibility. The valve plane is shifted slightly off-center to permit the nozzle assembly to be removed directly from the top. The combustion chamber dome shape is a large-radius dome for minimum stress and a sharp-cornered dome which permits an increase in piston length and reduces the piston crown area exposed to combustion. The cooling fins are set on the cylinder head at an angle of

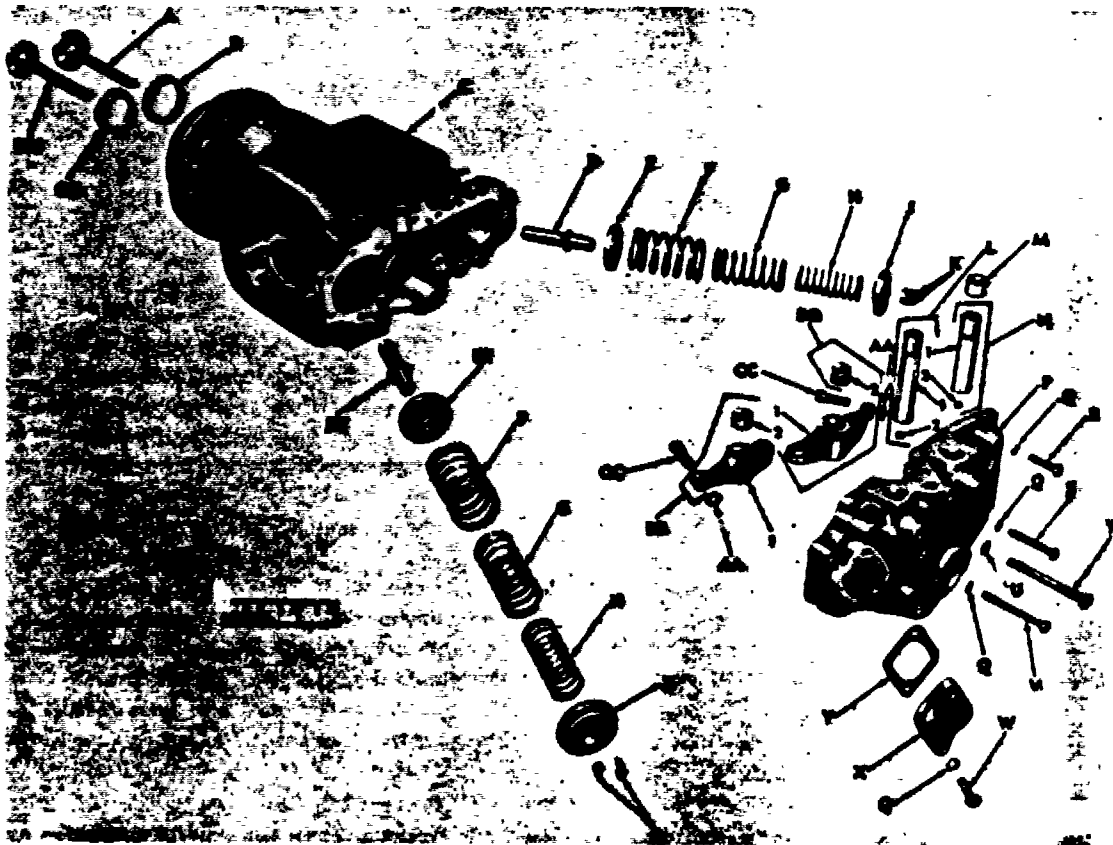

Figure 8. Cylinder assembly--exploded view.

OS 607, 2-P8

30° and reach from the intake to the exhaust side of the cylinder head, which provides ample cooling fin area. Cooling fins, exhaust and intake ports, and a single rocker box are cast integrally with the cylinder head. Valve guides and seats are shrunk into place in the cylinder head. The cylinder barrel is "chocked" at the head end to compensate for hot running conditions. An outer extension of the cylinder head encloses a recess or rocker box, which houses the valve stem inserts, valve springs, and related parts. The valve rocker arm assemblies are held in place by rocker shafts in the cylinder head valve rocker support cover.

(2) The intake and exhaust valves and seats are all fabricated from a common silicon-chrome valve steel. Due to the low exhaust temperature of the diesel cycle, there is no need for expensive alloys. However, the intake valve seat has a Stellite face to prevent wear. Otherwise, excessive wear will occur because of the completely dry inlet valve operation in a supercharged diesel engine. The stem of the intake valve and exhaust valve for each cylinder extends into the rocker boxes. Each valve has three nested springs compressed between two retainers and secured to the valve stems by split cone-shaped locks which hold each valve to its seat. The exhaust valves have a positive valve rotator which also serves as the lower spring retainer. Valve clearance adjusting screws with flat swivel pusher pads are mounted on one end of the valve rocker arms.

(3) Forged steel valve rocker arms with roller cam followers are used. The rollers are specially hardened and honed to provide an extremely smooth and permanent contact surface. Hollow rocker arm shafts and drilled passages in the rocker arms convey oil to all moving parts. Each rocker box has its own individual valve rocker arm cover; each cover contains one intake valve rocker arm and shaft and one exhaust valve rocker arm and shaft.

5. CRANKCASE, LIQUID-COOLED ENGINES.

a. The crankcase is that part of the engine that supports and encloses the crankshaft, provides a reservoir for the lubricating oil, and acts as a support for the oil pump, oil filter, and some of the other accessories. It is common practice to cast the upper part of the crankcase as part of the cylinder block. The lower part of the crankcase is the oil pan (AA, fig 9). This is bolted to the bottom of the block and is made of pressed or cast metal.

b. The crankcase also has the mounting brackets which support the entire engine on the vehicle frame, or on a subframe designed and constructed for that purpose. The engine mounting supports are an integral part of the crankcase, or they are bolted to it in such a way that they support the engine at three or four points. The points of contact with the frame are usually cushioned on rubber. The rubber mechanically insulates the frame and body of the vehicle from engine vibration and noise; also, it prevents frame distortion and damage to the engine supports and transmission from engine twisting.

6. CRANKCASE, AIR-COOLED OPPOSED AND V-TYPE ENGINES. In the air-cooled horizontal-opposed or V-type engines, the crankcase is the foundation of the engine since the individual cylinders are attached to it, the crankshaft is enclosed by it, and the oil pan and other parts are fastened to it. Figure 10 shows the crankcase and related parts of a 12-cylinder, air-cooled, V-type engine. The studs to which one bank of individual cylinders are attached can be seen along the upper left of the crankcase (D, fig 10). To permit higher stresses in the studs set in the aluminum casting, special Rosan inserts are installed so that the studs can be threaded into them. These inserts are screwed into the softer casting until they are slightly below the surface. When an insert is set, a lockring, broached to fit the splined end of the insert and course milled on its outer edge, is driven into a counterbore in the casting. This lockring holds the threaded insert in place and prevents any turning of the insert when a stud is installed or removed.

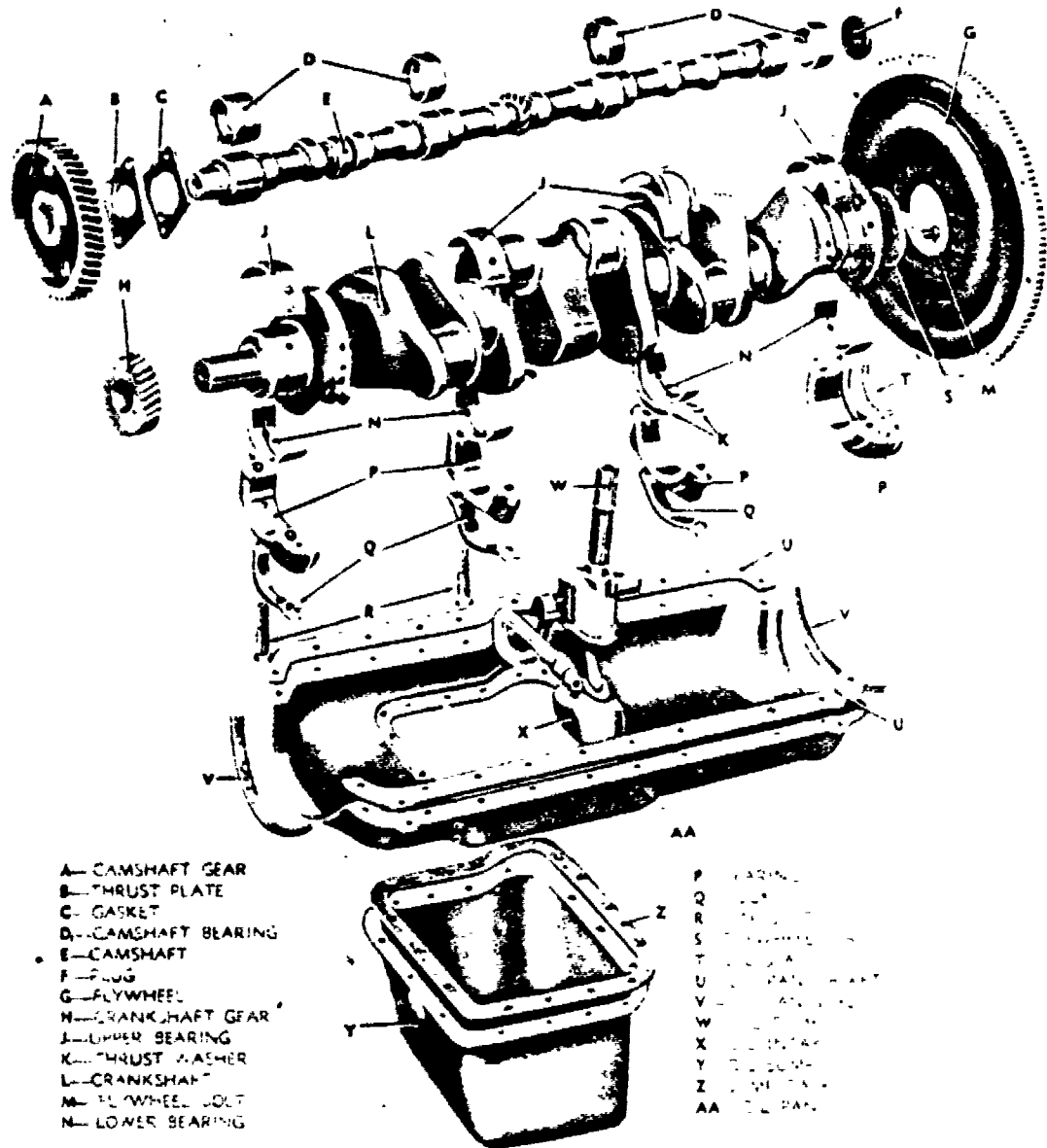

A—CAMSHAFT GEAR
 B—THRUST PLATE
 C—GASKET
 D—CAMSHAFT BEARING
 E—CAMSHAFT
 F—PLUG
 G—FLYWHEEL
 H—CRANKSHAFT GEAR
 I—UPPER BEARING
 K—THRUST WASHER
 L—CRANKSHAFT
 M—FLYWHEEL BOLT
 N—LOWER BEARING

AA—OIL PAN
 P—GASKET
 Q—THRUST PLATE
 R—GASKET
 S—THRUST PLATE
 T—GASKET
 U—THRUST PLATE
 V—GASKET
 W—THRUST PLATE
 X—THRUST PLATE
 Y—THRUST PLATE
 Z—THRUST PLATE

Figure 9. Oil pan and lower engine parts.

7. PISTONS.

a. Fitted into the bore of the cylinder is a movable piston that receives the energy or force of combustion and transmits that energy to the crankshaft through the connecting rod (fig 11). Automotive pistons ordinarily are made of cast iron or aluminum alloy. They must be lightweight, wear well, and have high strength. At the top and bottom of the strokes of the cycle, the piston must come to a complete stop and start again in the opposite direction. Considerable force is required to overcome the inertia of the piston when it stops and starts and, as the weight of the piston affects the inertia, it is desirable to keep the piston as light as possible. To reduce weight, the head and skirt of the piston are made as thin as is consistent with the strength required. Ribs are used on the underside of the piston to reinforce the head; they also assist in conducting heat from the head of the piston to the piston rings and out through the cylinder walls. Special ribs are used to reinforce the piston pin bosses.

OS 607, 2-P10

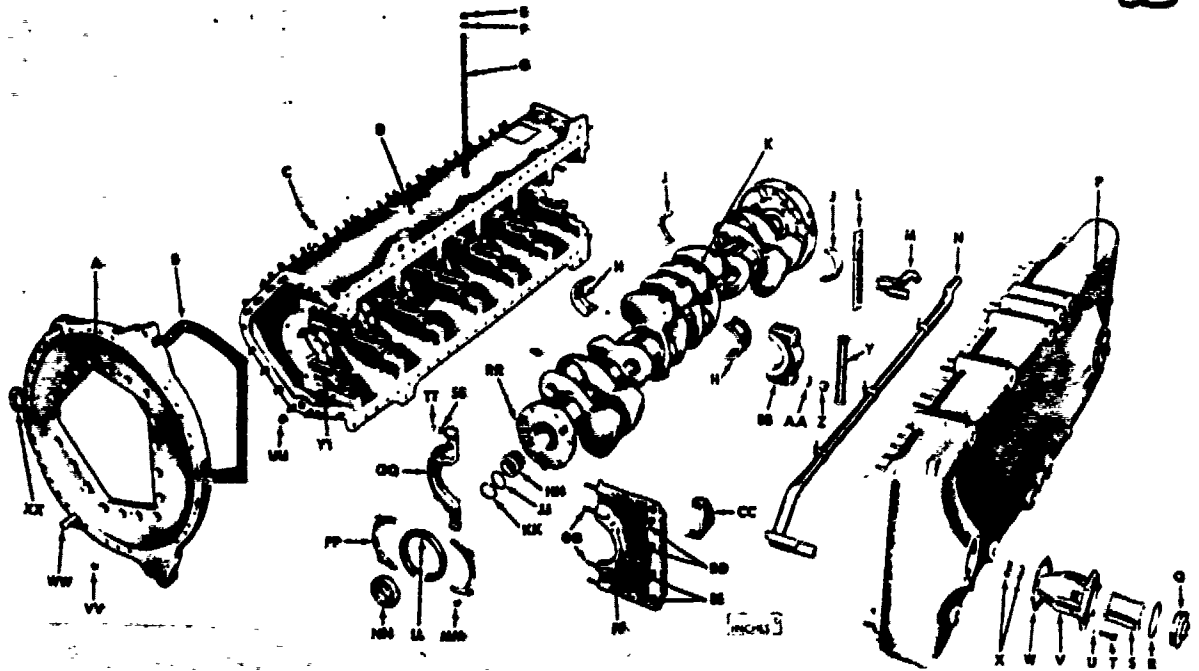

A	Transmission case adapter	Q	Oil sump screen plug	GG	Drilled stud
B	Adapter gasket	R	Annular gasket	HH	Crankshaft flywheel end plug
C	Rocker box oil drain line adapter	S	Oil sump screen assy	JJ	O-ring gasket
D	Crankcase	T	Drilled-head bolt	KK	Snap ring
E	Special nut	U	Plain washer	LL	Oil seal
F	Plain washer	V	Oil sump screen housing	MM	Drilled-head bolt
G	Crankcase cross bolt	W	Screen housing gasket	NN	Transmission shaft pilot ball bearing
H	Crankshaft thrust bearing	X	O-ring gasket	PP	Oil seal retaining plate
J	Crankshaft main bearing	Y	Crankcase cross bolt spacer	QQ	Crankshaft oil seal housing (upper)
K	Crankshaft	Z	Main bearing cap nut	RR	Dowel pin
L	Pressure oil line support bracket	AA	Main bearing cap washer	SS	Plain washer
M	Pressure oil pump inlet line assy	BB	Main bearing cap	TT	Slotted nut
N	Scavenger oil pump inlet line assy	CC	Scavenger oil line support bracket	UU	Pipe plug
P	Oil pan	DD	Transmission adapter stud	VV	Slotted nut
		EE	Drilled stud	WW	Dowel pin
		FF	Crankshaft oil seal housing (lower)		

Figure 10. Crankcase and related parts of a 12-cylinder, air-cooled, V-type engine.

b. The piston is kept in alignment by the skirt, which is usually cam ground and elliptical in cross section (fig 12). This elliptical shape permits the piston to fit the cylinder, regardless of whether the piston is cold or at working temperature. Its narrowest diameter is at the piston pin bosses where the metal is thickest. At its widest diameter, the piston skirt is thinnest. The piston is fitted to close limits at its widest diameter so that piston "slaps" will be prevented during engine warmup. As the piston is expanded by the heat generated during operation, it becomes round because the expansion is proportional to the temperature of the metal. The walls of the skirt are cut away as much as possible to reduce weight and to prevent excessive expansion during engine operation. Many aluminum pistons are made with split skirts, so that when the pistons expand the skirt diameter will not increase. The two types of piston skirts found in engines are the full trunk

36

and the slipper. The full trunk-type skirt, which is more widely used, has a full cylindrical shape with bearing surfaces parallel to those of the cylinder, thus giving more strength and better control of the oil film. The slipper-type skirt has considerable relief on the sides of the skirt, which leaves less area for possible contact with the cylinder walls and thereby reduces friction.

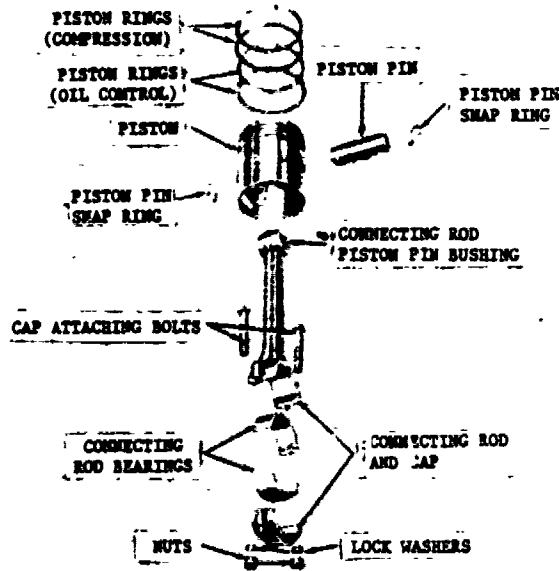

Figure 11. Piston, piston rings, connecting rod, and connecting rod bearings.

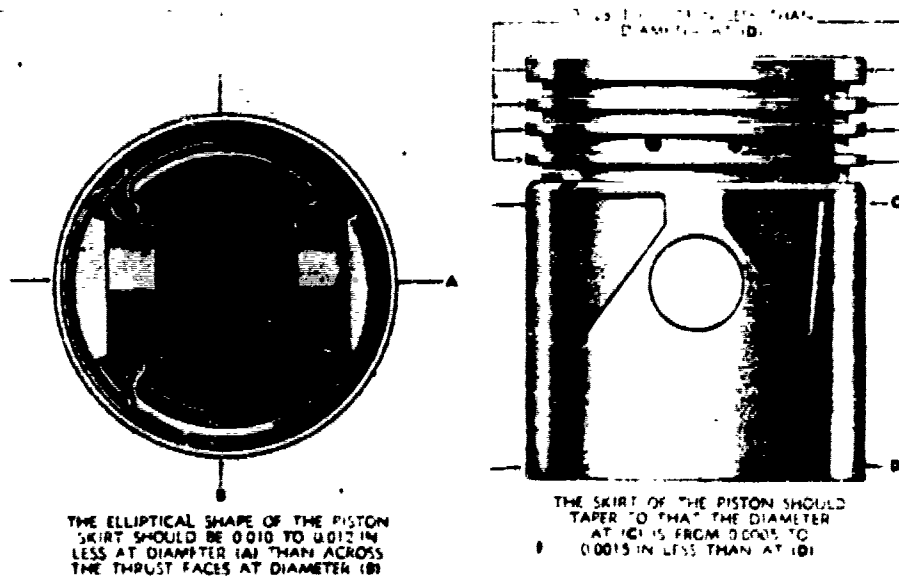

Figure 12. Cam ground piston.

OS 607, 2-P12

c. It is common practice today for some manufacturers to use pistons that have been plated with a soft material such as tin. The purpose is to have the tin work into and fill the pores of the cylinder wall as the engine is broken in. The result is a more perfect fit between the piston and cylinder wall and a shorter breaking-in period. Aluminum pistons are often "anodized" to make the outside surface harder. Anodizing is a process whereby the piston is oxidized by electrolysis. It produces an aluminum oxide coating over the entire surface of the piston. This coating is very hard and highly resistant to wear. Because of the softness of aluminum, pistons made of this material, unless properly treated, may pick up gritty particles which will become embedded in the piston and cause scratches and wear in the cylinder walls.

8. PISTON RINGS.

a. Purpose and construction. Piston rings are used on pistons to maintain gastight seals between the pistons and cylinders, to assist in cooling the piston, and to control cylinder wall lubrication. About one-third of the heat absorbed by the piston passes through the rings to the cylinder wall. Although piston rings have been made from many materials, cast iron has proved the most satisfactory as it withstands heat, forms a good wearing surface, and retains a greater amount of its original elasticity after considerable use. More recently, piston rings are being plated with various metals to produce better wearing qualities. There are two types of piston rings: compression rings and oil regulating rings (fig 13).

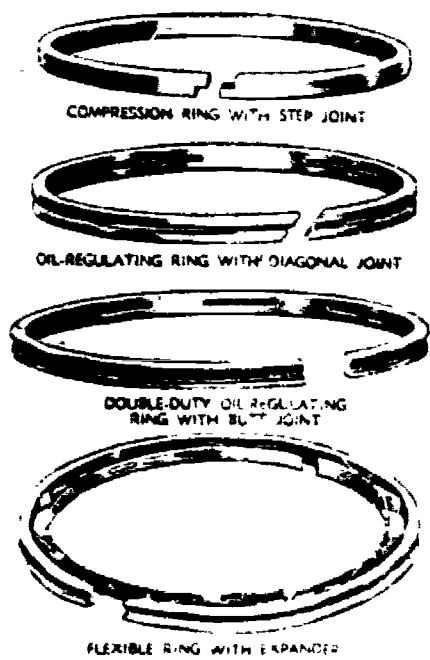

Figure 13. Piston rings.

b. Compression ring. The principal function of a compression ring is to prevent gases from leaking by the piston during the compression and power strokes. All piston rings are split to permit easy assembly to the piston and to allow for expansion. When the ring is in place, the ends of the split joint do not form a perfect seal; therefore, it is common practice to use more than one ring and to stagger the joints around the piston. If the cylinders are worn, expanders are sometimes used to insure a perfect seal.

c. Oil regulating ring. The lowest ring above the piston pin is usually an oil regulating ring. This ring scrapes the excess oil from the cylinder walls and returns some of it, through slots, to the piston ring grooves. The ring groove under an oil ring is provided with openings through which the oil flows back into the crankcase. In some engines, an additional oil ring is used in the skirt below the piston pin to provide better oil control. Steel sideplates are sometimes used on 2- and 3-section oil regulating rings.

9. PISTON PINS.

a. The piston is attached to the connecting rod by means of the piston pin. This pin passes through the piston pin bosses and through the upper end of the connecting rod which rides within the piston on the middle of the pin. Piston pins are made of alloy steel with a precision finish and are case hardened; sometimes they are chromium plated to increase their wearing qualities. Their tubular construction gives them a maximum of strength with a minimum of weight. They are lubricated by splash from the crankcase or by pressure through passages bored in the connecting rods.

b. There are three methods of fastening a piston pin (fig 14) to the piston and connecting rod.

(1) An anchored or "fixed" pin is attached to the piston by a screw running through one of the bosses; the connecting rod oscillates on the pin.

(2) A "semifloating" pin is anchored to the connecting rod and turns in the piston pin bosses.

(3) A "full-floating" pin is free to rotate in the connecting rod and in the bosses, but is prevented from working out against the sides of the cylinder by plugs or snapping locks.

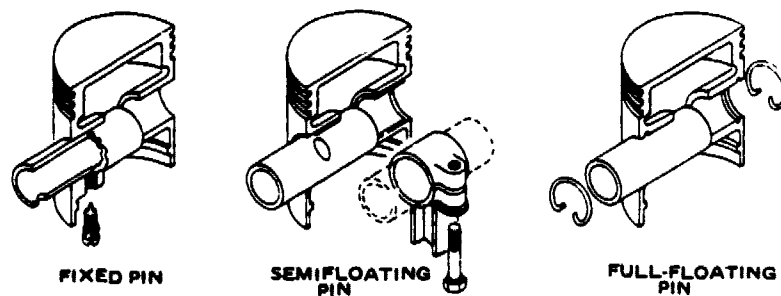

Figure 14. Piston pin arrangements.

10. CONNECTING RODS.

a. The connecting rods (fig 11) connect the pistons with the crankshaft. They must be lightweight and yet strong enough to transmit the thrust of the pistons. Automotive connecting rods are drop-forged from a steel

39

alloy capable of withstanding heavy loads without deflection; that is, without bending or twisting. The connecting rod generally is made in the form of an I-beam for lightness with maximum strength. Holes at the upper and lower ends are machined to permit accurate fitting of bearings. These holes must be parallel.

b. The upper end of the connecting rod is connected to the piston by the piston pin. If the piston pin is locked in the piston pin bosses or if it floats in both the piston and the connecting rod, the upper hole of the connecting rod will have a solid bearing (more commonly called a bushing) of bronze or similar material. As the lower end of the connecting rod revolves with the crankshaft, the upper end is forced to turn back and forth on the piston pin. Although this movement is not great, the bushing is necessary because the temperatures and unit pressures exerted are high. If the piston pin is semifloating, a bushing is not needed.

c. The lower hole of the connecting rod is split to permit it to be clamped around the crankshaft. The bottom part, or cap, is made of the same material as the rod and is attached by two or more connecting rod bolts. The surface that bears on the crankshaft is generally a bearing material in the form of a separate split shell, although, in a few cases, it may be spun or die-cast in the inside of the rod and cap during manufacture. The two parts of the separate bearing are positioned in the rod and cap by dowel pins, projections, or short brass screws. The shell may be of babbitt metal face-spun or die-cast on a backing of bronze or steel. Split bearings may be of the precision or semiprecision type.

(1) The precision type is accurately finished to fit the crankpin and does not require further machining during installation. It is positioned by projections on the shell which match reliefs in the rod and cap. The projections prevent the bearings from moving sideways, but they permit rotary movement after the bearing cap is removed, thus making it possible to replace the bearing without removing the connecting rod from the engine.

(2) The semiprecision type is usually fastened to the rod and cap. Prior to installation, it is machined to the proper inside diameter with the cap and rod bolted together.

11. CRANKSHAFT.

a. Function. The crankshaft may well be called the backbone of the engine as it ties together the reaction of all the pistons, transforms the reciprocating motion of the pistons and connecting rods into rotary motion, and transmits the resulting torque to the flywheel and clutch. The crankshaft (fig 15) is a shaft with one or more throws along its length. The arrangement of the throws along the shaft is determined by the desired firing order of the engine cylinders and the desired direction of rotation of the engine. The firing order is regulated by the relationship of the camshaft and the crankshaft.

Construction. Crankshafts are first forged or cast from an alloy of steel and nickel. The rough casting or forging is then machined. When all the rough machining is completed, the nonbearing surfaces are plated with a light coating of copper. After the plating process is completed, the whole crankshaft is placed in a carburizing oven or an electroinduction furnace where surfaces of the crankshaft not coated with copper become alloyed with the carbon, which produces a thin, hard surface or bearing area. This process is known as casehardening. The crankshaft is completed by grinding the casehardened surfaces.

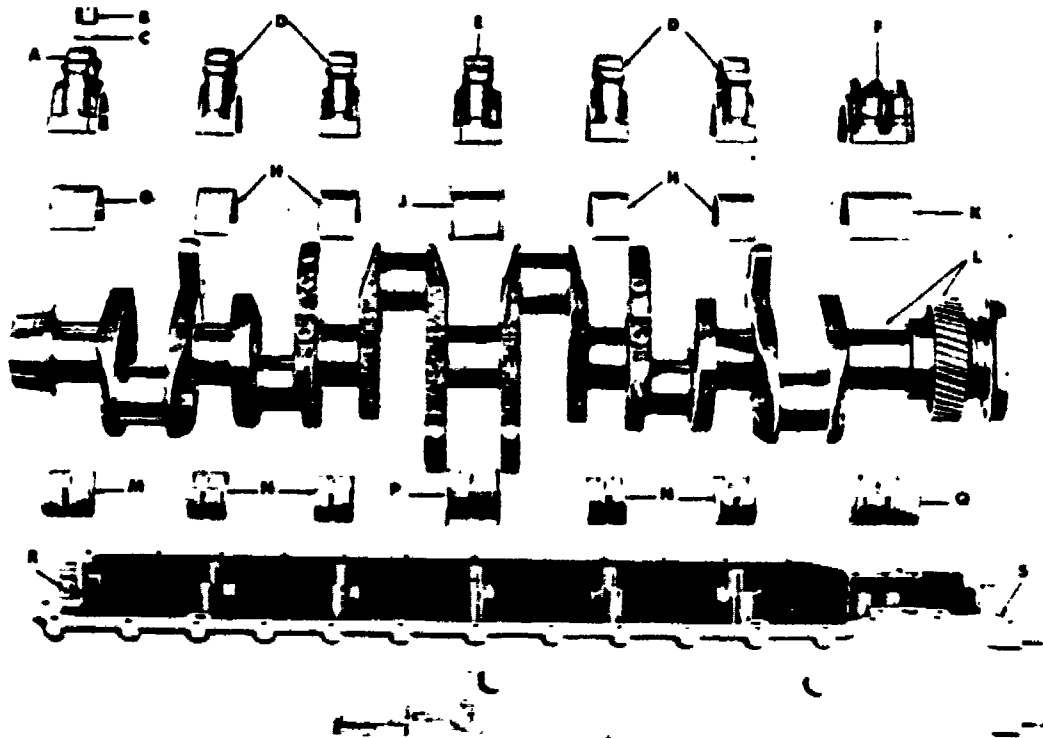

- | | | |
|---------------------------------|-----------------------------|------------------------------|
| A—MAIN BEARING CAP—FRONT | N—MAIN BEARING SHELL— | N—MAIN BEARING SHELL— |
| B—MAIN BEARING STUD NUT | INTERMEDIATE (CAP HALF) | INTERMEDIATE (CASE HALF) |
| C—MAIN BEARING STUD NUT WASHER | J—MAIN BEARING SHELL—CENTER | P—MAIN BEARING SHELL REAR |
| D—MAIN BEARING CAP—INTERMEDIATE | (CAP HALF) | (CASE HALF) |
| E—MAIN BEARING CAP—CENTER | K—MAIN BEARING SHELL—REAR | R—MAIN BEARING STUD |
| F—MAIN BEARING CAP—REAR | (CAP HALF) | S—CRANKCASE ASSEMBLY (UPPER) |
| G—MAIN BEARING SHELL—FRONT | L—CRANKSHAFT ASSEMBLY | |
| (CAP HALF) | M—MAIN BEARING SHELL—FRONT | |
| | (CASE HALF) | |

Figure 15. Crankshaft and bearings.

c. Throw arrangements (fig 16). Crankshafts for 4-cylinder engines have either three or five points of support (i.e., supporting bearings). The four throws are in one plane, the throws for cylinders No 2 and 3 being advanced 180° over the throws for cylinders No 1 and 4. A crankshaft for an 8-cylinder, V-type engine could be of the same basic design with two connecting rods being connected to each throw. For better balance and smoother operation, a variation of the 8-cylinder, V-type crankshaft has two throws on each bank advanced 90° over the other two throws. Crankshafts for 8-cylinder, in-line engines follow two general designs. The first design has two identical four-throw arrangements positioned end to end, with one set advanced 90° over the other. This is known as a 4-4 shaft. In the other design, the 2-4-2 shaft, a set of four throws is positioned between two sets of two throws each. The end cylinders are advanced 90° over the center group. Crankshafts for 6-cylinder engines have either three, four, or seven points of support. The throws for the connecting rod bearings are forged in three planes 120° apart, with two throws in each plane. Throws No 1 and 6 are in the first plane, No 2 and 5 are in the second, and No 3 and 4 are in the third. The crankshafts for 12-cylinder, V-type engines are basically the same as the shafts for 6-cylinder engines.

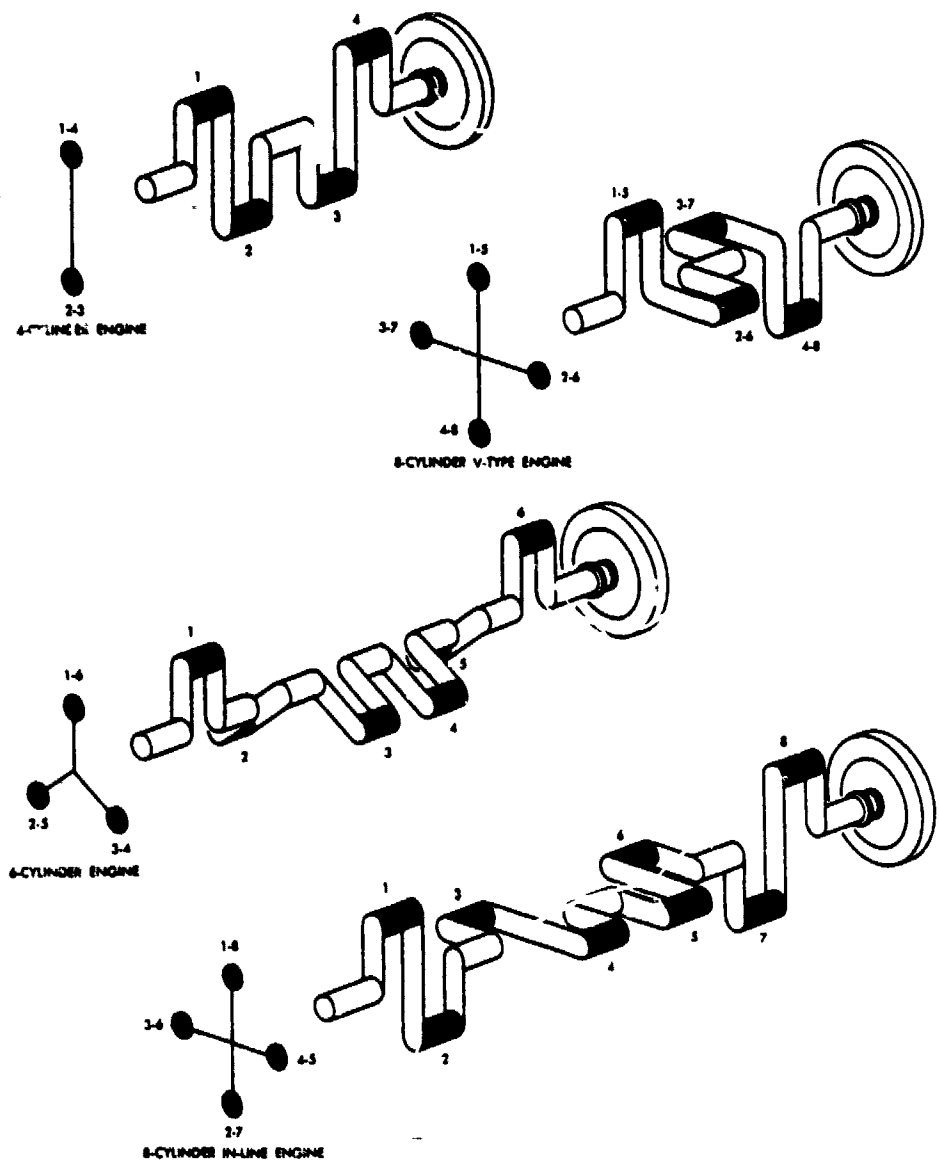

Figure 16. Crankshafts and throw arrangements.

d. Crankshaft stress. Any piece of rotating machinery has a certain definite speed at which it will start to vibrate excessively--this is called the critical speed. In designing a crankshaft, it is sometimes possible to place this critical speed outside the speed range of the engine. If not, the crankshaft must be heavy enough to withstand the vibration. In severe cases of vibration, the crankshaft may break; to run smoothly, a crankshaft must be statically and dynamically balanced. Crankshaft deflection caused by load stresses will often throw a shaft out of balance, especially at high speeds. To overcome vibration, uneven balance, and load deflection, crankshafts are balanced by use of weights. These weights may be forged as part of the shaft (fig 15) or they may be bolted on.

42

e. Torsional vibration. Torsional vibration is a twisting vibration. It usually is noticeable in in-line 6- and 8-cylinder engines with long crankshafts. Assume that the crankshaft is made of rubber. When the front cylinder is fired it would tend to turn the crankshaft very rapidly but the inertia of the flywheel would tend to prevent this rapid increase in speed at the rear of the crankshaft. The result is a "winding up" of the "rubber" crankshaft. As the force exerted by the front cylinder decreases, the rubber crankshaft will "unwind." This repeated winding and unwinding sets up a twisting or torsional vibration. A steel crankshaft will not distort like rubber, but it distorts enough to have torsional vibration.

f. Damping torsional vibration. To reduce or eliminate torsional vibration, devices variously called crankshaft-torque impulse neutralizers, torsional balancers, or vibration dampers are used. Essentially, all work in a very similar manner. They all employ a damper plate or flywheel that can have some movement independent of the crankshaft even though rotating with the crankshaft. This independent movement tends to oppose or absorb the winding and unwinding of the crankshaft, thereby opposing torsional vibration.

(1) One type of vibration damper is shown in figure 17. A metal damper flywheel is held on the crankshaft hub by a friction clutch. The friction clutch slips when sudden speed changes occur. For example, the crankshaft has been wound up and then starts to unwind. This gives certain sections of it a momentary increase in speed. The damper flywheel continues its steady rotation, however, since the friction clutch slips. This slipping action actually imposes a drag on the crankshaft, thereby damping out twisting vibration. Similarly, if the crankshaft receives an impulse that tends to wind it up, the vibration damper opposes the action. However, the amount of actual movement of the crankshaft as it winds up or unwinds is very small, but it would be sufficient to cause trouble if some type of vibration damper were not used.

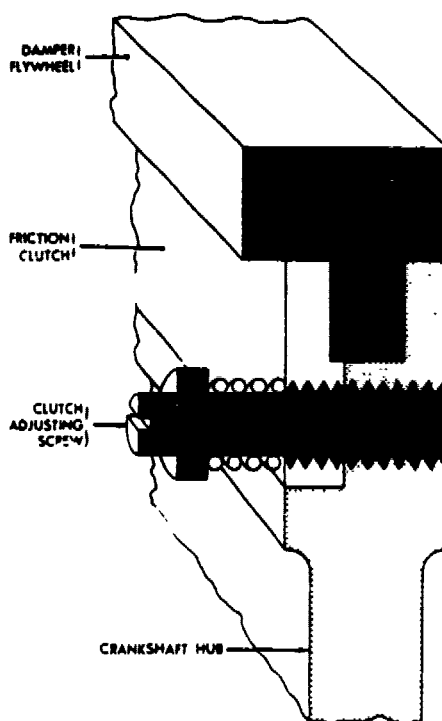

Figure 17. One type of vibration damper.

OS 607, 2-P18

43

(2) A second type of vibration damper makes use of a series of rubber cones or sleeves. These support a damper plate or damper flywheel that presses against friction faces located on the fan pulley. The rubber compresses one way or the other so that the damper flywheel rubs against the friction faces, thereby imposing a dragging restraint on the crankshaft during sudden speed changes. It acts in the same way as the friction clutch described above. Instead of rubber cones, a series of springs may be used.

12. FLYWHEEL. A flywheel (fig 18) stores up energy of rotation when the instantaneous torque on the crankshaft is greater than average, and it releases this energy when the torque is less than average. In this way, fluctuations in engine speed are reduced to within very small limits. The size of the flywheel required, therefore, varies with the number of cylinders and the general construction of the engine. With a large number of cylinders and the consequent overlapping of power impulses, there is less need for a flywheel; consequently, the flywheel can be relatively smaller. The flywheel rim carries a ring gear, either integral with the flywheel or shrunk on, that meshes with the starter driving gear for cranking the engine. The rear face of the flywheel is usually machined and ground and acts as one of the pressure surfaces for the clutch, thus becoming part of the clutch assembly.

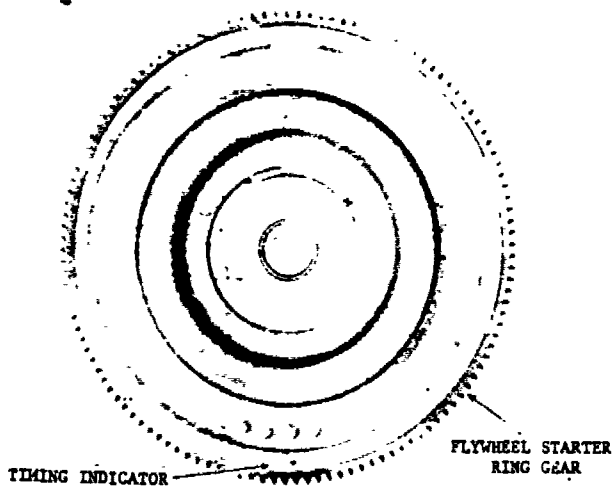

Figure 18. Flywheel.

13. MAIN BEARINGS.

a. The crankshaft of an engine rotates in main bearings. These bearings are located at both ends and at certain intermediate points along the crankshaft. In in-line and V-type engines, the main bearings are supported by webs in the lower part of the cylinder block; in high-speed automotive engines, these are the thin shell bronze- or steel-backed type such as the main bearing shells shown in figure 15.

b. One-half of the shell fits into the cap. The upper half fits into fixed recesses in the lower part of the cylinder block. The two-part precision shell bearing is highly desirable because it can be easily replaced and does not require scraping and fitting. It has one principal disadvantage, however, in that it cannot be line-bored or reamed to allow for

OS 607, 2-P19

44

warpage of the crankshaft or block. If there is warpage, certain bearing areas are subjected to excessive wear. The precision bearing also is more expensive, but its advantages more than offset its disadvantages. The principal load on the main bearings is radial, but the small end thrust load on the crankshaft is taken up by a main bearing that is provided with lip or thrust faces, and acts as a combination radial and thrust bearing, as is the center main bearing shell in figure 15. The main bearings are often channel d for oil distribution and may be lubricated with crankcase oil by pressure through drilled passages or by splash. To prevent loss of engine lubricating oil, oil seals are placed at the main bearings where the crankshaft extends through the crankcase

14. VALVES AND VALVE SEATS.

a. Valves. Every cylinder of a 4-stroke-cycle gasoline engine must have at least one intake valve to permit the mixture to enter the cylinder and one exhaust valve to allow the burned gases to escape (except for certain special designs which may utilize a single valve for both functions). The type of valve usually used in automotive engines is called a poppet, mushroom, or tulip valve (fig 19). The word "poppet" is derived from the popping action of the valve, and the words "mushroom" and "tulip" from the general shape of the valve. A valve usually is made in one piece from special alloy steel. The intake valves ordinarily are made of chromium nickel alloy and the exhaust valves of silichrome alloy because of the extremely high temperatures that they must withstand. In some engines, especially the air-cooled types, the exhaust valve contains sodium in a sealed cavity extending from the head through the stem (fig 19). The sodium conducts heat away from the head to the stem, from where it is conducted to the valve guide, thus aiding in cooling. When sodium-filled valves become unserviceable, they must be disposed of in accordance with existing regulations, since sodium will explode if it comes in contact with water.

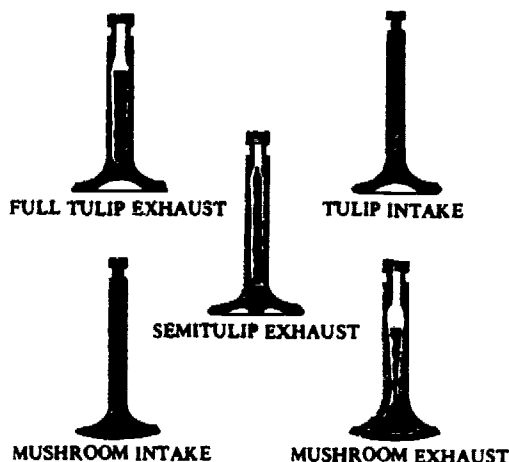

Figure 19. Valve types.

b. Valve seats. The valve seat is the face of the circular opening leading into the combustion chamber of the cylinder. There are at least two such openings or ports in each cylinder, to which are connected the intake and exhaust manifolds. Since exhaust valve seats are subjected to intense heat, valve grindings and reseatings are necessary from time to time to renew the seating surfaces. Regrindings can be minimized by using nickel chrome cast iron alloy in the cylinder castings or by using valve seat inserts. These inserts are rings of special alloy fitted into place in the cylinder block or cylinder head. Inserts can be used with both exhaust and intake valves, but are more frequently used with exhaust valves only.

45

c. Valve guides. Valve stems are ground to fit the guides (fig 20) in which they operate. The reamed hole in the guide must be aligned and square with the valve seat to insure proper seating of the valve. The guides may be integral parts of the cylinder block or cylinder head, depending on the type of valves used, or they may be removable sleeves which can be replaced when worn. Removable valve guides are usually made of cast iron. Valve heads and seats are cooled by the transfer of heat to adjacent metals, which are cooled by the surrounding water.



Figure 20. L-head valve operating mechanism.

15. VALVE OPERATING MECHANISM.

a. The valve operating mechanism for one valve of an in-line, L-head engine is shown in figure 20. The camshaft is turned at one-half crankshaft speed by means of a pair of meshing gears, one on the crankshaft the other on the camshaft, or by two sprockets and a chain. The camshaft has a cam for each valve. As the camshaft rotates, the cam lobe moves up under the valve tappet exerting an upward thrust through the tappet against the valve stem. This thrust overcomes the valve spring pressure as well as gas pressure in the cylinder, thus causing the valve to be raised off its seat. When the lobe moves from under the tappet, the valve spring pressure reseats the valve.

b. The valve operating mechanism of an in-line, valve-in-head (overhead valve) engine is shown in figure 21. In this arrangement, the valve tappet is raised by the cam lobe and this movement lifts the push rod. The rocker arm is thereby turned or rotated a few degrees on its shaft, which causes the valve end of the rocker arm to move downward. This downward movement pushes the valve off its seat. Then, when the lobe moves from under the valve tappet, the valve spring pressure reseats the valve and also pushes the rocker arm back up in readiness for the next operation of the valve.

OS 607, 2-P21

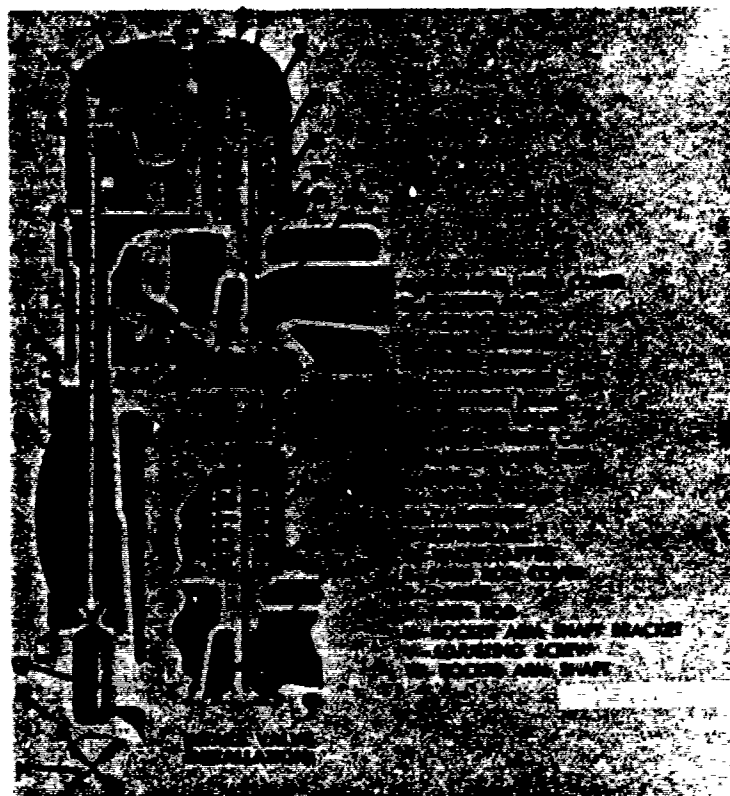

Figure 21. Overhead valve mechanism.

c. When the overhead valve arrangement is used in a V-type engine, both valve tappets and push rods operate off a single camshaft which is located above the crankshaft. That is, the push rods are located inside the V formed by the two banks of cylinders.

d. An overhead valve arrangement is also used on opposite cylinder engines, except that a separate camshaft operates each bank of opposed cylinder tappets, push rods, and rocker arms, and the camshafts, in turn, are actuated by an accessory drive gear train.

e. Hydraulic valve tappets are used on many engines. The operation of one type of hydraulic valve tappet mechanism is shown in figure 22. Oil under pressure is forced into the tappet when the valve is closed, and this extends the plunger in the tappet so that all valve clearance, or lash, is eliminated. When the cam lobe moves around under the tappet and starts to raise it, there will not be any tappet noise. As the lobe starts to raise the tappet, the oil is forced upward in the lower chamber of the tappet. This action closes the ball check valve so oil cannot escape. Now, the tappet acts as though it were a simple, one-piece tappet and the valve is opened. When the lobe moves out from under the tappet and the valve therefore closes, the pressure in the lower chamber of the tappet is relieved. Any slight loss of oil from the lower chamber is then replaced by the oil pressure from the engine lubricating system. This causes the plunger to move up snugly against the push rod so that any clearance is eliminated.

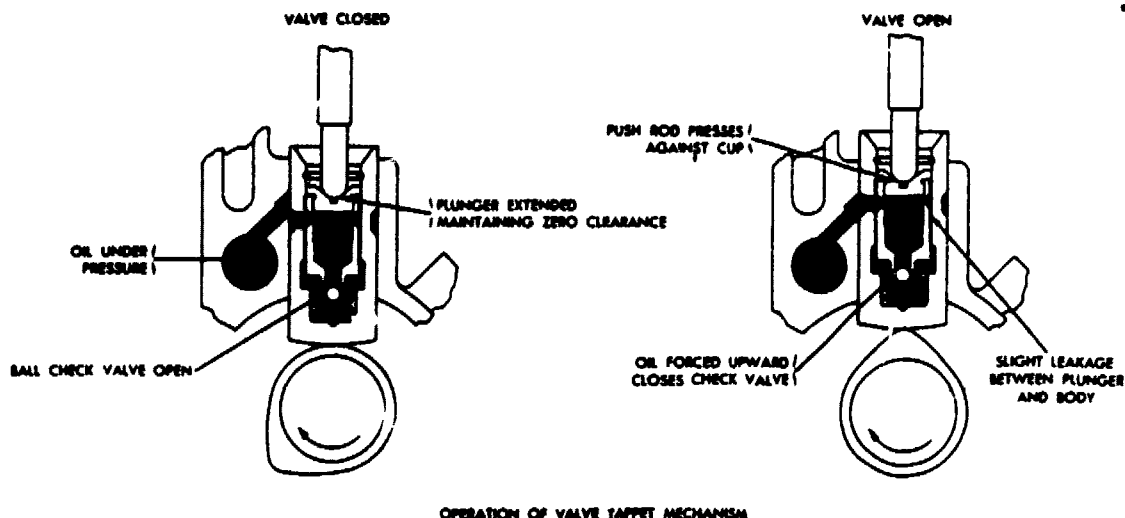

Figure 22. Hydraulic valve showing tappet action--cutaway views.

f. An overhead camshaft is used on some of the larger engines with overhead valves. The overhead camshaft eliminates the long linkages otherwise necessary in an overhead valve engine with a camshaft placed in the cylinder block. Figure 23 illustrates the valve mechanism of two cylinders in a 12-cylinder, V-type, air-cooled engine. A camshaft is required for each bank of cylinders. The camshaft cannot be seen because it is inside the intercylinder connectors. The inner ends of the rocker arms ride directly on the cams of the camshaft. As the lobe of a cam moves up under a rocker arm, the rocker arm rocks on its supporting shaft causing the valve stem to be pushed down so that the valve is opened. When the lobe moves on around out of the way, the valve spring pressure reseats the valve. In the application shown, the rocker arms have rollers on the camshaft ends. The rollers roll on the cams so that friction and wear are greatly reduced.

16. POWER PACKAGE CONCEPT.

a. The present trend in the design of military equipment is toward what is termed the power package concept. That is, the equipment is so designed that the engine, together with the radiator, transmission, clutch, and other attached parts, can be removed as a unit or package from the vehicle. This greatly facilitates repair and helps reduce "dead vehicle" time. When a vehicle requires major engine work, it is not necessary to tie up the vehicle while the work is done. Instead, the old powerplant can be removed and a new one quickly installed.

b. To facilitate quick removal and installation of a powerplant, the electrical system has quick-disconnect conduit plugs, and the various mounting bolts and mechanical linkages (to carburetor, clutch, and transmission) are readily accessible. This greatly reduces the time needed to perform all disconnect operations.

48

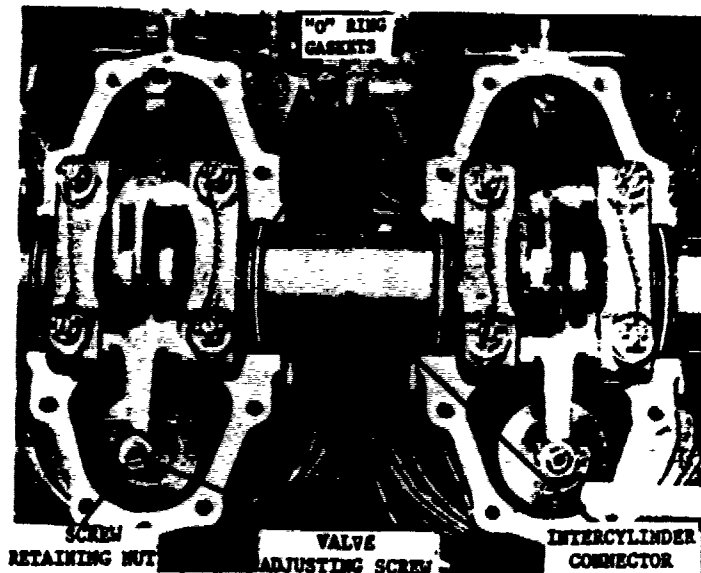

Figure 23. Valve mechanism of an overhead valve, overhead camshaft engine.

17. ENGINE FAMILIES. To simplify the service parts problem in the field by providing maximum interchangeability, and also to simplify servicing and training procedures, the present trend in military engine design is toward what is termed engine families. There must, of necessity, be many different kinds of engines because there are many kinds of jobs to do; e.g., from powering a tank to powering a 1/4-ton truck, or from running a large power-plant to running a small auxiliary generator in a tank. However, the service and service parts problem can be simplified by so designing engines that they are closely related in cylinder size, valve arrangement, etc. As an example, one 800-hp engine uses the same connecting rod, piston, and piston rings as a similar but smaller 500-hp engine. As another example, an opposed cylinder, 6-cylinder, air-cooled engine is rated at 500-hp supercharged or 375-hp non-supercharged. Practically the only difference in these two engines, aside from the supercharger, is in the pistons. The 500-hp supercharged engine has pistons designed for a compression ratio of 5.5:1. The 375-hp nonsupercharged engine has differently shaped pistons which are designed for a higher compression ratio of 6.5:1.

EXERCISE

11. What material is presently used in the construction of engine cylinder blocks?
 - a. Cast aluminum
 - b. Special iron alloy
 - c. Gray cast iron

12. Why are cylinder liners more advantageous than cast en bloc cylinders in large motor vehicle engines?
 - a. They wear longer
 - b. They hold compression better
 - c. They are easier to cool

OS 607, 2-P24

13. How is the aluminum alloy head secured to the cylinder barrel on an air-cooled engine?
 - a. Bolted
 - b. Screwed and shrunk
 - c. Welded
14. What is secured to the upper part of the crankcase of a liquid-cooled engine?
 - a. Engine mounting brackets
 - b. Engine oil sump
 - c. Engine oil intake
15. Why are piston skirts designed in an elliptical shape?
 - a. To compensate for the thrust on the connecting rod
 - b. To provide a better piston-cylinder fit at any temperature
 - c. To allow a greater amount of oil on the cylinder walls
16. Why are some pistons plated with soft metal?
 - a. To allow for rapid expansion of the pistons
 - b. To increase the engine break-in time
 - c. To fill in small holes in the cylinder walls
17. Why are all piston rings split?
 - a. To reduce the amount of expansion
 - b. To permit easy assembly to the piston
 - c. To form a more perfect seal
18. Which type mounting uses TWO snapping locks to retain the piston pins?
 - a. Full-floating
 - b. Fixed
 - c. Anchored
19. The arrangement of the throws along the crankshaft MUST be in accordance with the
 - a. length of the piston strokes.
 - b. desired rated speed of the engine.
 - c. desired firing order of the cylinders.
20. What TWO throws of an 8-cylinder, in-line, engine crankshaft are in the same plane?
 - a. 1 and 6
 - b. 2 and 7
 - c. 4 and 7
21. What is the purpose of a flywheel?
 - a. To eliminate crankshaft vibration
 - b. To overcome torsional vibrations
 - c. To reduce engine speed fluctuations

22. What prevents end thrust movement of a crankshaft?
- Thrust bearings on each end of the shaft
 - Thrust faces on each main bearing web
 - Lip faces on one or more of the main bearing shells
23. Which statement is correct?
- Intake valves commonly contain sodium in a cavity in the stem
 - Exhaust valves are normally constructed of chromium nickel alloy
 - Valve heads are cooled by transferring heat to the valve seat
24. What is ONE advantage of an overhead camshaft?
- Operating efficiency of the engine is increased
 - Long linkages to the rocker arms are eliminated
 - Engine vibration at idling speeds is decreased
25. What is gained by the use of the engine families concept?
- The compression ratios can be varied more easily.
 - The engines can operate on any fuel available in the field
 - A greater interchangeability of parts is provided

CORRESPONDENCE COURSE
of the
US ARMY ORDNANCE
CENTER AND SCHOOL



LESSON ASSIGNMENT SHEET

- Ordnance Subcourse No 607. Engine Principles
- Lesson 3 Compression Ignition and Gas Turbine Engines
- Credit Hours Three
- Lesson Objective After studying this lesson you will be able to explain the principles of diesel, multifuel, and gas turbine engines, and make a comparison of compression ignition and spark ignition engines.
- Text Attached Memorandum
- Materials Required Answer sheet and exercise response list
- Suggestions. None

STUDY GUIDE AND ATTACHED MEMORANDUM

1. INTRODUCTION.

- a. The keynote of future wars will be mobility. Mobility implies more transport of more people and more weapons than we have ever known before. The vehicles needed to accomplish greater mobility may some day be powered by turbines, free piston engines, or nuclear reactors. For the present, however, our vehicles must rely on conventional piston engines.
- b. The single factor of fuel consumption is being attacked, not because of the dire prophecies of ultimate depletion of our petroleum resources, but because reduction in fuel consumption by our forces means overall reduction in expenditures of time, machines, and transportation.
- c. Since the piston engine remains our primary powerplant, it is obvious that maximum improvement in economy must be achieved through the use of compression ignition engines.

2. DIESEL ENGINES.

- a. Definition. A diesel engine is an internal combustion engine in which ignition is derived from the heat of compression. The diesel engine requires no aid for ignition; the fuel being ignited solely by contact with the air heated during the compression stroke.

OS 607, 3-P1
December 1975



b. History. The diesel engine bears the name of Dr. Rudolph Diesel, a German engineer. He is credited with constructing, in 1897, the first successful diesel engine using liquid fuel. His objective was an engine with greater fuel economy than the steam engine, which used only a small percentage of the energy contained in the coal burned under its boilers. Dr. Diesel originally planned to use pulverized coal as fuel, but his first experimental engine in 1893 was a failure. After a second engine also failed, he changed his plan and used liquid fuel. The engine then proved successful.

c. Applications. The early diesel engines were quite large and heavy compared to gasoline engines and were used chiefly for heavy-duty stationary applications. However, the diesel engine of today can be used for almost as many purposes as can the gasoline engine. Constant improvement through the years has brought them to the point where they can be used successfully in trucks and buses. They are still relatively heavy and expensive (initial cost) when compared to their gasoline counterparts, but their high thermal efficiency makes them quite suitable for any heavy-duty application, where, during a long period of time, they will pay for themselves many times over in fuel savings. One of the most recent applications has been in the field of armored combat vehicles with the introduction of the M60 tank, which is powered by an air-cooled diesel engine.

d. Diesel engine classifications. The major classification of American diesel engines is made by the speed at which the engine normally operates. The Society of American Engineers has set up a standard classification that is followed by all American manufacturers. This classification is as follows:

- (1) Low speed - below 500 RPM.
- (2) Medium speed - 500 to 1,000 RPM.
- (3) High speed - over 1,000 RPM.

e. General mechanical construction. The diesel engine is mechanically similar to the gasoline engine, but it is somewhat heavier in construction due to higher cylinder pressures. Both engine types utilize air, fuel, compression, and ignition. Intake, compression, power, and exhaust occur in the same sequence; arrangements of pistons, connecting rods, and crankshafts are similar. Both are internal combustion engines; that is, they extract energy from a fuel-air mixture by burning the mixture inside the engine.

f. Comparison of the 4-stroke-cycle diesel and gasoline engines.

(1) Fuel intake and ignition of fuel-air mixture. In principles of operation, the main difference between 4-stroke-cycle gasoline and diesel engines (fig 1 and 2) is the two methods of introducing the fuel into the cylinder and of igniting the fuel-air mixture. Fuel and air are mixed together before they enter the cylinder of a gasoline engine. The mixture is compressed by the upstroke of the piston and is ignited within the cylinder by a spark plug. (Devices other than spark plugs, such as "firing tubes," are sometimes used.) Air alone enters the cylinder of a diesel engine on the intake stroke. This air is compressed by the upstroke of the piston and the diesel fuel is injected into the combustion chamber near the top of the upstroke (compression stroke). The air becomes greatly heated during compression and the diesel fuel ignites and burns as it is injected into the heated air. No spark plug is used in the diesel engine; ignition is by contact of the fuel with the heated air, although "glow plugs" are used in some models of diesel engines to assist in starting. Pressure developed by the compression stroke is much greater in the diesel engine in which pressures as high as 500 pounds per square inch (PSI) are common. For each pound

of pressure exerted on the air, there will be a temperature increase of about 2° F. At the top of the compression stroke (when the pressure is highest), the temperature in the chamber will be about 1,000° F. This heat ignites the fuel almost as soon as it is injected into the cylinder, and the piston, actuated by the expansion of the burning gases, then moves down on the power stroke. In a gasoline engine, the heat from compression is not enough to ignite the fuel-air mixture and a spark plug is therefore necessary.

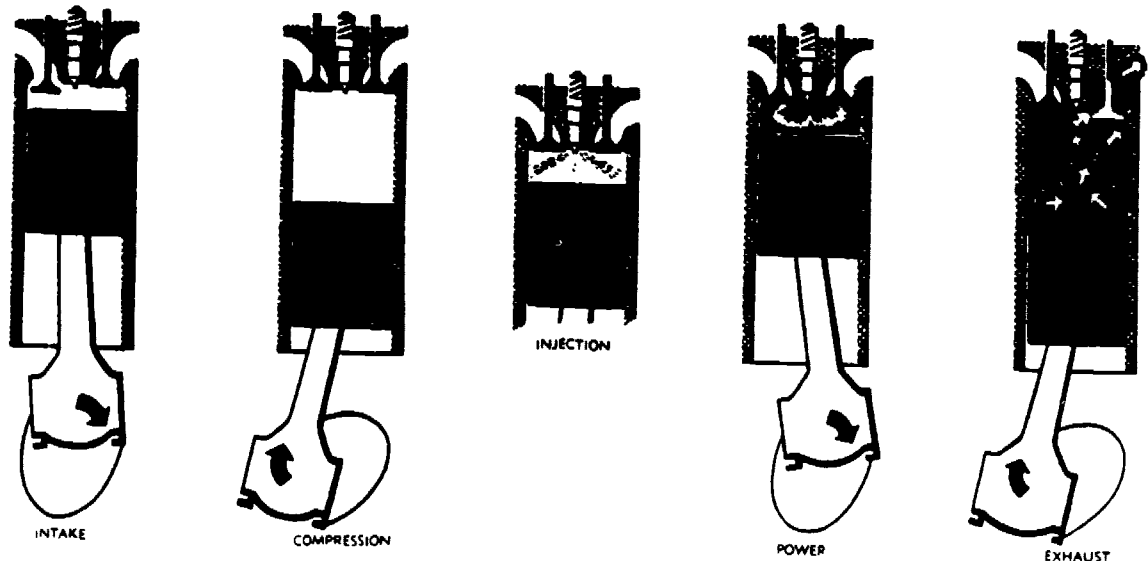

Figure 1. Four-stroke-cycle diesel engine.

(2) Control of speed and power. The speed and the power output of diesel engines are controlled by the quantity of fuel injected into the cylinder. This is opposed to the common gasoline engine that controls speed and power output by limiting the amount of air admitted to the carburetor. The difference is that the diesel engine controls the quantity of fuel, whereas the gasoline engine regulates the quantity of air. In the diesel engine, a varying amount of fuel is mixed with a constant amount of compressed air inside the cylinder. A full charge of air enters the cylinder on each intake stroke. Because the quantity of air is constant and the amount of fuel injected is below the maximum established by the manufacturer in designing the engine, there is always enough air in the cylinder for complete combustion. A device in the carburetor of the gasoline engine controls the amount of air admitted. The amount of air and its velocity, in turn, control the quantity of fuel that is picked up and mixed with air to be admitted to the cylinder. The amount of mixture available for combustion determines power output and speed. It is apparent, therefore, that the controlling factor in the speed and power output of a gasoline engine is the quantity and velocity of air passing through the carburetor.

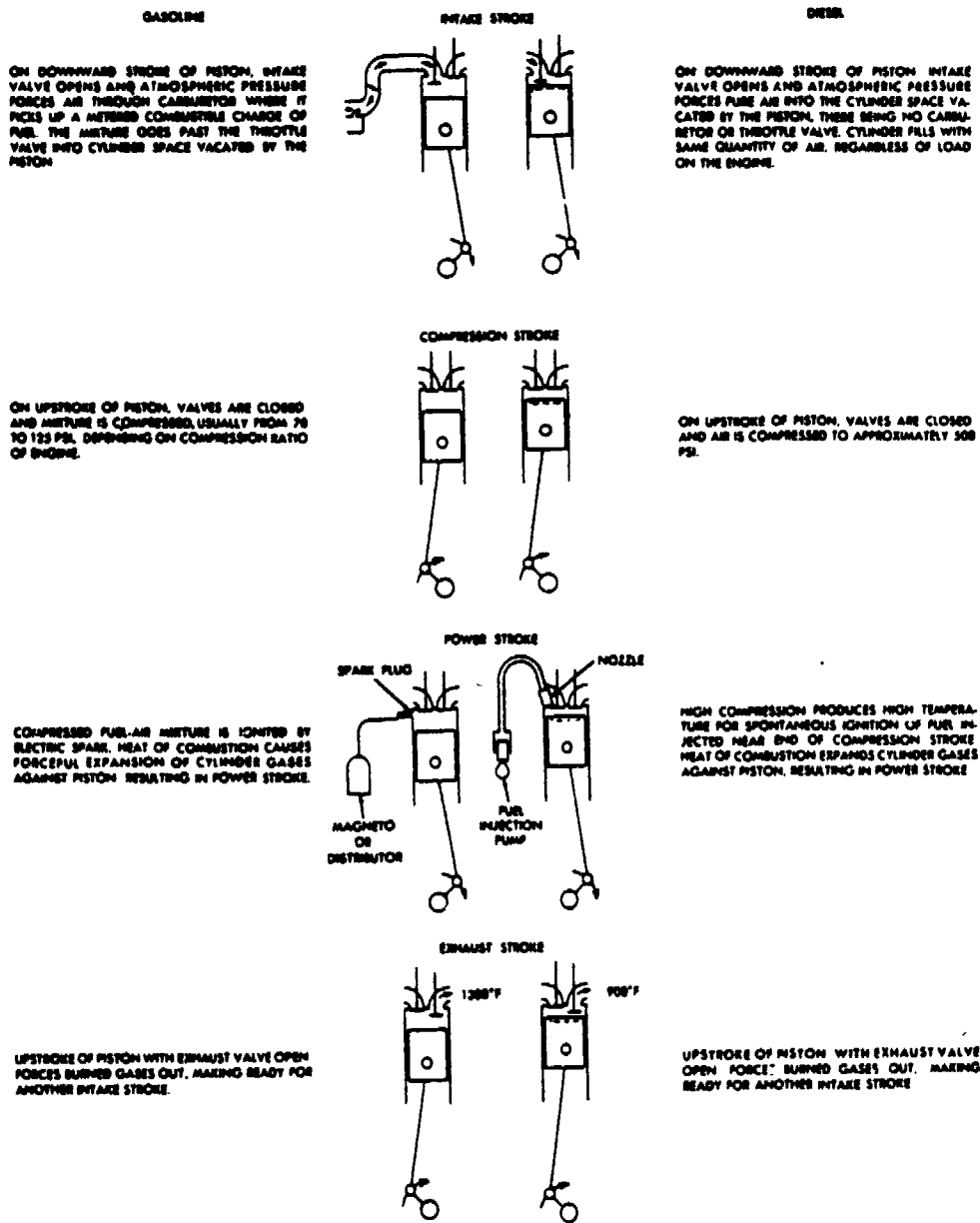

Figure 2. Comparison of sequence of events in diesel and gasoline engines.

(3) Combustion process. In the diesel engine there is continuous combustion during the entire length of the power stroke, and the pressure resulting from combustion remains approximately constant throughout the stroke. In the gasoline engine, however, combustion is completed while the piston is at the upper part of its travel. This means that the volume of the mixture stays about the same during most of the combustion process. When the piston does move down and the volume increases, there is little additional combustion to maintain pressure. Because of these facts, the cycle of the gasoline engine is often referred to as having constant volume combustion while the diesel cycle is said to have constant pressure combustion.

8. Principles of the 2-stroke diesel cycle.

(1) Operating principles. The 2-stroke diesel cycle differs from the 4-stroke cycle in that one power stroke occurs for each revolution of the crankshaft (fig 3). Intake, compression, injection, power, and exhaust still take place, but they are completed in just two strokes on the piston (one revolution of the crankshaft). Also, in most engines there are no intake or exhaust valves, but rather there are intake and exhaust ports which are cut into the cylinder wall. These ports are covered and uncovered by the piston at the proper times to provide for the intake of air and the exhausting of the products of combustion. Some engines utilize intake ports in the cylinder wall, but have exhaust valves in the top of the combustion chamber. One of the main advantages of using ports rather than valves is that there are fewer moving parts in the engine, and thus fewer maintenance problems. Since the time for intake and exhaust is limited in the 2-stroke diesel cycle engine, air is usually supplied under pressure by a blower. Because the products of combustion are usually being exhausted when the intake ports are uncovered, the incoming air helps push these exhaust gases out of the cylinder. This effect is called scavenging, and the airflow during scavenging in a typical 2-stroke-cycle diesel engine can be seen in the upper left-hand illustration in figure 3. Another advantage of scavenging is that, since the blower supplies air to the cylinders under pressure, more air can enter the cylinders than would be able to enter if the pressure were atmospheric. Thus, there is more oxygen available for the combustion of the diesel fuel.

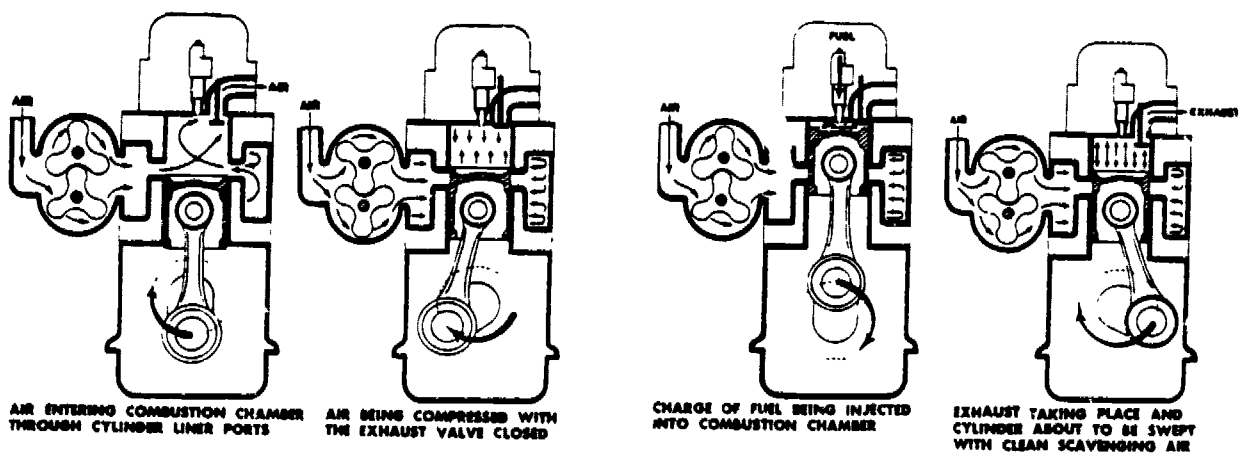

Figure 3. Schematic diagrams depicting the 2-stroke diesel engine.

(2) Applications. The 2-stroke cycle is used for both spark ignition and compression ignition engines. However, its use for the spark ignition engine is normally restricted to those of low power output, such as power lawnmowers, portable air compressors, and portable marine engines. The 2-stroke gasoline engine is rather inefficient because some of the incoming charge, which includes fuel, may be lost to the atmosphere through the exhaust ports in order to obtain high power output per unit displacement. The diesel engine made the 2-stroke cycle practical. It will be recalled that the intake charge of the diesel engine consists only of air. Therefore, no potential chemical energy is lost should some of the charge be expelled to the atmosphere through the exhaust ports. In fact, such a condition will assure more complete scavenging of exhaust gases and, hence, a maximum amount of air is available in the combustion chamber to burn the incoming fuel.

h. Comparison of the 2-stroke and 4-stroke diesel cycles. As with gasoline engines, since the 2-stroke cycle has one power stroke per crankshaft revolution while the 4-stroke cycle produces one power stroke per two revolutions, it should first appear as though the 2-stroke-cycle diesel engine would be capable of delivering twice as much power as a 4-stroke-cycle diesel engine of the same piston displacement. However, there are many practical considerations which limit the power of a 2-stroke-cycle engine to less than twice as much as the output of a comparable 4-stroke-cycle engine. Due to the factors discussed in the next two paragraphs, it will be seen that both the 4-stroke-cycle and the 2-stroke-cycle diesel engines have their relative advantages and disadvantages.

(1) Characteristics affecting power output. To allow for reasonable scavenging of the exhaust gases from the cylinder of a 2-stroke engine, the exhaust valves or ports must open earlier than in a 4-stroke-cycle engine. Thus, the effective power stroke in a 2-stroke-cycle engine is shorter than in a 4-stroke-cycle engine with the same total piston travel. In addition, the incoming air must help scavenge the exhaust gases in a 2-stroke-cycle engine and, thus, less air is actually available for combustion purposes than in a 4-stroke-cycle engine with the same piston displacement. This is compensated for, to a certain extent, by the fact that most 2-stroke-cycle diesel engines use a blower that forces air into the cylinder under pressure. Also, the power required to drive the blower on a 2-stroke-cycle engine must be furnished by the engine itself, which, of course, decreases the power output.

(2) Heat dissipation characteristics. An important factor to consider when evaluating the relative merits of the 2-stroke and 4-stroke diesel cycles is heat dissipation characteristics. In a 4-stroke-cycle engine, there is more opportunity for the dissipation of heat from valves, pistons, and other critical engine parts, since a power stroke occurs on every other revolution; whereas, in the 2-stroke-cycle engine, a power stroke occurs on every revolution of the crankshaft. In view of this, 4-stroke-cycle engines can operate without experiencing overheating or valve damage. This can be somewhat compensated for in 2-stroke-cycle engines through a proper cooling system design.

i. Diesel fuels. The fuels used in modern high-speed internal combustion diesel engines are a product of the petroleum refining process. They are heavier than gasoline because they are obtained from the leftovers, or residue, of the crude oil after the more volatile fuels, such as gasoline and kerosene, have been removed. The large, slow turning diesel engines used in stationary or marine installations will burn almost any grade of heavy fuel oil, but the high-speed diesel engines used in automotive installations require a fuel as light as kerosene. Although the diesel fuel is different from gasoline, its specification requirements are just as exacting as those of gasoline. Of the various properties to be considered in selecting a fuel for diesel engines, the most important are cleanliness, viscosity and ignition quality.

(1) Cleanliness. Probably the most necessary property of a diesel fuel is cleanliness. The fuel should not contain more than a trace of foreign substance; otherwise, fuel pump and injector difficulties will occur. Diesel fuel, because it is heavier and more viscous than gasoline, will hold dirt in suspension for longer periods of time. Therefore, every precaution must be taken to keep dirt out of the fuel system or to eliminate it before it reaches the pumps. Water is more objectionable in diesel fuels than it is in gasoline because it will cause ragged operation and corrode the fuel system. The least amount of corrosion of the accurately machined surfaces in the injection equipment will cause it to become inoperative. Careful filtration is especially necessary to keep diesel engines efficient. Diesel fuels are more viscous than gasoline. They contain more gums and more abrasive particles, which may cause premature wear of the injection equipment. The abrasives may consist of material difficult to eliminate during the process of refining, or they may enter the fuel tank through careless refueling. Whatever the source, it is imperative that means be provided to protect the system from these abrasives. Most diesel engine designs include at least two filters in the fuel supply systems to protect the closely fitted parts in the pumps and nozzles. The primary (coarser) filter is usually located between the supply tank and the fuel supply pump and the secondary (finer) filter between the fuel supply pump and the injection pump. Additional filtering elements are frequently installed between the injection pump and the nozzle. Diesel fuel oil filters are referred to as full-flow filters, since all fuel must pass through the filters before reaching the injector pumps. Filters must be inspected regularly and cleaned or replaced if maximum efficiency is to be maintained. There are two types of fuel filters used in the fuel supply systems of diesel engines--metal-disk-type and cloth-bag-type filter elements. A diesel oil filter usually incorporates an air vent to release any air that might accumulate in the filter during operation.

(a) All metal-disk-type filters have a cleanable element; metal filters are used as primary filters because the fine particles that may pass through them are not injurious to the supply pump, as they would be to the injection pump. After removing the shell, which acts as a settling chamber, the strainer assembly can be removed and cleaned with a suitable liquid cleaning solution.

Caution. Do not use compressed air on the strainer assembly disks.

Some fuel filters incorporate a cleaning knife. Solids larger than 0.005 inch remain on the outside of the element, and the cleaning knife serves to scrape the deposits off the filtering disks. The solids fall to the bottom of the housing where they can be removed through the drain plug hole. A ball relief valve in the filter cover enables the oil to bypass the filter element if the disks become clogged.

(b) The cloth-bag-type (fabric) filters, because of their greater filtering qualities, are used principally as main filters for protecting the fuel injection pump. Many of the filters in use are similar to the lubricating oil filter. In this type of filter, the element is not cleanable and must be replaced. The filtering medium is a large bag of close, evenly woven, lintless, acid-resisting textile material. Maximum benefit is derived from the bag's large area by keeping the sides of the bag separated by a wire screen mat. The screen is the same size as the bag, and the two are detachably fastened to a central feeding spool and wound around it. Layers of bag and screen are thus alternated through the winding, and the entire surface of the bag is available for filtering purposes. The fuel to be filtered flows from the filter inlet at the top, through the spool, and out the ports to the inside of the bag. The dirt, solids, abrasives, carbon, etc, are caught in the bag, and the clean fuel passes outward and to the filter outlet.

(2) Viscosity and pour point. The viscosity and pour point of a fuel indicate its fluidity. Viscosity is the term used to indicate the internal friction or resistance to flow of a liquid. It is measured in seconds, the time required for a measured quantity of liquid fuel at 100° F to pass through a calibrated hole in a viscometer. The lowest temperature at which fuel oil will just flow (under controlled test conditions) is called the pour point. It indicates the suitability of the fuel for cold weather engine operation, since the fuel must remain fluid in order to be handled by the fuel system. Unless arrangements are made for heating, the fuel must not be more viscous than 550 seconds at the lowest operating temperature, or it will not flow through the fuel system. While maximum viscosity is limited by handling considerations, minimum viscosity is also limited by injection system requirements. The fuel must have sufficient body to lubricate the closely fitted pump and nozzle plungers properly. In order to do this and to prevent wear, scoring, and sticking, the fuel should have a viscosity greater than 35 seconds at 100° F. The fuel must also be viscous enough to prevent leakage at the pump plungers and "dribbling" at the injection nozzle. Leakage occurs when the fuel viscosity is less than 34 or 38 seconds at 100° F, depending upon the type, temperature, and pressure of the injection system. Fuel shipped from a refinery is usually free from water and sediment. Diesel fuel, being more viscous than gasoline, will hold dirt in suspension longer. As it is transferred from tank to tank from the refinery to the engine, it will sometimes pick up sufficient water and sediment to corrode the fuel pump parts or injection system parts. To prevent this, care must be exercised in handling fuel and line fuel strainers must be adequate to remove any water or sediment which has found its way into the fuel; therefore, the filters must be checked frequently. A fuel's viscosity also determines the size of the fuel-spray droplets which, in turn, govern the atomization and penetration qualities of the spray.

(3) Ignition quality.

(a) The ignition quality of a diesel fuel is its ability to ignite spontaneously (without mechanical assistance, such as a spark) under the conditions existing in the engine cylinder. The spontaneous ignition point of a fuel is a function of temperature, pressure, and time. A fuel with a good ignition quality (one that will ignite at low temperatures) is most desirable for diesel engines for several reasons. Smoking, knocking, and ease of starting are somewhat dependent on the ignition quality of the fuel. An engine will start if, after compression, the temperature in the engine cylinder is above the ignition temperature of the fuel. Compression temperature is related to outside air temperature; so, the lower the ignition temperature of the fuel, the lower the possible atmospheric temperature at which the engine will start. If the ignition temperature of a fuel is too high, the engine will smoke--particularly at light loads when engine temperatures are low. Diesel fuels (like gasoline) are composed of fractions or parts, each having different characteristics; some are light and volatile and others heavy and less volatile. The lighter parts will ignite at a lower temperature, while the heavier parts require a higher temperature to ignite. The ignition quality of diesel fuels is indicated by cetane numbers, just as octane numbers are used to indicate the antiknock quality of gasoline. The ignition quality of a diesel fuel is determined by comparing it with a standard reference fuel, according to the cetane number scale. To obtain the cetane number of a fuel, a special test engine is used. This engine, operating under controlled conditions and using a mixture of cetane that has good ignition qualities and alpha-methyl-naphthalene that has poor ignition qualities, is used to establish a standard of measurement.

(b) The cetane number of a fuel is the percentage of cetane that must be mixed with alpha-methyl-napthalene in order to duplicate the ignition quality of the diesel fuel being tested. Thus, if a fuel has the same ignition quality as a reference fuel composed of 60 parts cetane and 40 parts alpha-methyl-napthalene, the fuel has a cetane number of 60. The ignition quality most suited for any particular engine is best determined by trial, or the engine manufacturer might recommend the fuel most suited for his particular engine. At present, most diesel engines require fuels within the range of 30 cetane number to 60 cetane number. Very little demand exists for fuels outside of this range. The recommendation of a fuel most suited for a particular engine requires consideration of more than one (good ignition quality) factor for good engine operation, such as load, engine speed, time, and atmospheric temperature. The lower the atmospheric temperature, the lower the temperature will be in the engine combustion chamber; therefore, the temperature in the combustion chamber might be below the required temperature to ignite the fuel. Consequently, in extreme cold areas some type of special aid must be employed to get the engine started. This aid may be either the application of heat to the inlet manifolds or jackets to heat the air entering the engine cylinders, or the use of electrically heated glow-plugs which will raise the air temperature locally in the engine for starting only, or the use of an ether or other cartridge which provides a mixture ignitable at well below normal temperatures. The time factor could be incorrect due to combustion chamber design, speed of injection, plus other factors which are noted in (4) below. A fuel having good ignition qualities will ignite and start to burn at the very beginning of injection and before all the fuel hits the air. It will continue to burn progressively as it is injected into the cylinder. Thus, this condition must exist to obtain maximum power and smooth engine operation and avoid detonation. Mainly, this is accomplished by combustion chamber, injection nozzle, and injection pump design.

(4) Knocking. It has been observed that compression ignition engines knock particularly at light loads. This knock is believed to be due to the rapid burning of the charge of fuel accumulated during the delay period between the time of injection and ignition. When the fuel is injected, it must first vaporize, then superheat until it finally reaches the spontaneous-ignition temperature under the proper conditions to start combustion. Time is required for sufficient fuel molecules to go through this cycle to permit ignition. This time is called ignition lag or ignition delay. During this same time, other portions of the fuel are being injected and are going through the same phases, but behind the ignition portion; therefore, as the flame spreads from the point of ignition, appreciable portions of the charge reach their spontaneous ignition temperatures at particularly the same instant. This rapid burning causes a very rapid increase in pressure, which is accompanied by a distinct and audible knock. Increasing the compression ratio will decrease the ignition lag and thereby decrease the tendency to knock; whereas, increasing the compression ratio in a gasoline engine (spark ignition) leads to preignition and, in addition, tends to make detonation worse. Knocking in the diesel engine (compression ignition) is affected by a large number of factors besides compression ratio; i.e., the type of combustion chamber, airflow within the chamber, the type of nozzle, the injection pressure conditions, the fuel temperature, and the air temperature are all factors, as are the characteristics of the fuel itself. For these reasons, more can be done in the design of a diesel engine to make it operate smoothly without detonation than is possible with the gasoline engine.

j. Types of combustion chamber. The fuel injected into the combustion space of a diesel engine must be thoroughly mixed with the compressed air and distributed as evenly as possible throughout the chamber. None of the liquid fuel should strike the chamber walls. It is essential that the shape of the combustion chamber and the characteristics of the injected fuel spray be closely related. There are many types of combustion chambers in use today, but they are all designed to produce one effect--to bring sufficient air into contact with the injected fuel to provide complete combustion at a constant rate. All modern combustion chamber designs may be classified under one of the following headings: open, precombustion, turbulence, or divided chambers. Designs which fall under two or more headings will be covered under the heading which is the most applicable.

(1) Open chamber. The open chamber (fig 4) is the simplest form of chamber, but its use is limited to slow-speed engines and a few high-speed, 2-stroke-cycle engines. The fuel is injected directly into the combustion space at the top of the cylinder. The combustion space, formed by the top of the piston and the cylinder head, is shaped to provide a swirling action of the air as the piston comes up on the compression stroke. There are no special cells, pockets, or passages to aid the mixing of fuel and air. This type of chamber requires higher injection pressures and a greater degree of fuel atomization than is required by the other types to obtain the same degree of mixing.

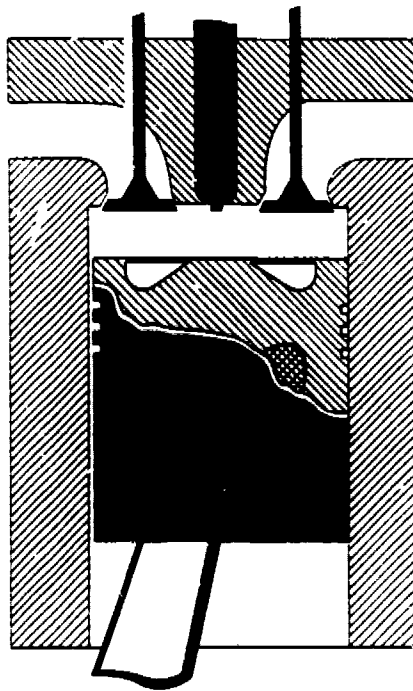

Figure 4. Open combustion chamber.

(2) Precombustion chamber. The precombustion chamber (fig 5) is an auxiliary chamber at the top of the cylinder. It is connected to the clearance volume above the piston through a restricted throat or passage. The precombustion chamber conditions the fuel for final combustion in the cylinder and distributes the fuel throughout the air in the cylinder in such a way that complete, clean burning of all the fuel is assured. On the compression stroke of the engine, air is forced into the precombustion chamber and, since the air is compressed, it becomes hot. Thus, at the beginning of injection this small chamber contains a definite volume of air. Consequently, combustion of the fuel actually starts in the precombustion chamber, since the fuel is injected into the chamber. Only a small part of the fuel is burned in this chamber because there is only a limited amount of oxygen present with which it can unite. The small predetermined amount that burns creates heat that, in turn, creates high pressure within the precombustion chamber; as injection continues, this high pressure forces the fuel at great velocity into the cylinder. There is ample oxygen present in the cylinder to burn all the fuel completely, regardless of the speed or load under which the engine is operating. Fuel injection pressures need not be as high with this type of chamber as in the open fuel type. A coarser spray is satisfactory because the function of the chamber is to vaporize the fuel further before it enters the cylinder.

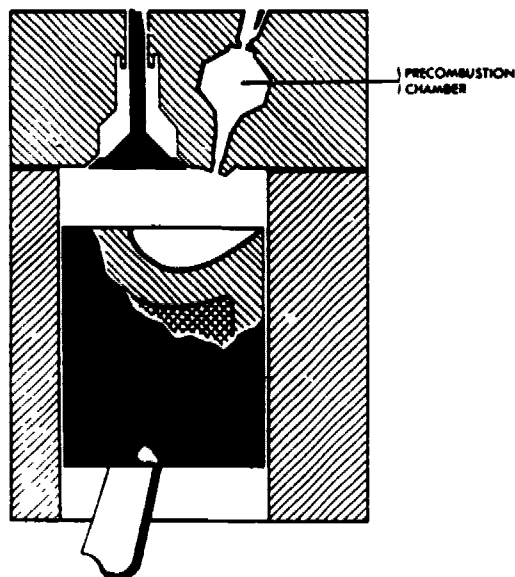

Figure 5. Diesel engine precombustion chamber.

(3) Turbulence chamber. The turbulence chamber (fig 6) is similar in appearance to the precombustion chamber, but its function is different. There is very little clearance between the top of the piston and the head, so that a high percentage of the air between the piston and the cylinder head is forced into the turbulence chamber during the compression stroke. The chamber is usually spherical, and the opening through which the air must pass becomes smaller as the piston reaches the top of the stroke, thereby increasing the velocity of the air in the chamber. This turbulence speed is approximately 50 times crankshaft speed. The fuel injection is timed to occur when the turbulence in the chamber is the greatest. This insures a thorough mixing of the fuel and the air, with the result that the greater

greater part of combustion takes place in the turbulence chamber itself. The pressure created by the expansion of the burning gases is the force that drives the piston downward on the power stroke.

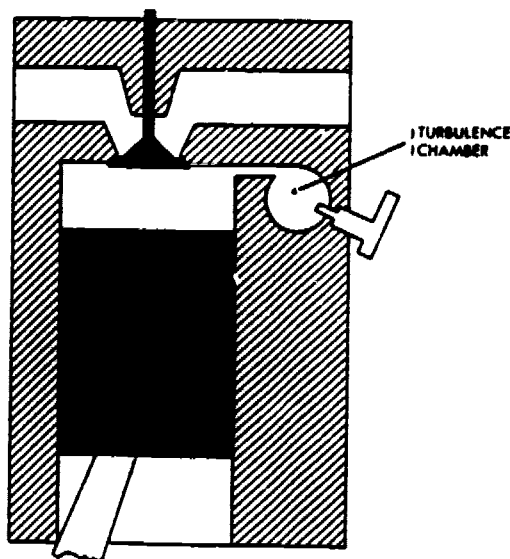

Figure 6. Diesel engine turbulence chamber.

(4) Divided chamber.

(a) The divided chamber (fig 7), or combination precombustion chamber and turbulence chamber, probably is better known by the trade name "Lanova combustion chamber." Like the open chamber combustion system, the combustion is controlled. Like the turbulence chamber type, the Lanova system depends on a high degree of turbulence to promote thorough mixing and distribution of the fuel and air, but, unlike it, this entails no increase in pumping losses. Ninety percent of the combustion chamber is directly in the path of the in-and-out movement of the valves. The turbulence in the Lanova system is dependent upon the thermal expansion and not on engine speed, as are the other systems.

(b) Primarily, the Lanova system involves the combination of the figure 8-shaped combustion chamber, situated centrally over the piston, and a small air chamber known as the energy cell. In its latest development, this energy cell is comprised of two separate chambers--an inner and an outer. The inner chamber, which is the smaller of the two, opens into the narrow throat between the two lobes of the main combustion chamber through a funnel-shaped venturi passage. The larger outer chamber communicates with the inner one through a second venturi. Directly opposite the energy cell is the injection nozzle.

(c) During the compression stroke, about 10 percent of the total compressed volume passes into the energy cell, the remainder staying in the figure 8-shaped combustion chamber. The fuel is injected in the form of a pencil stream that passes directly across the narrow throat of the combustion chamber, most of it penetrating into the energy cell. A small portion of the boundary layer follows the curvature of the combustion chamber lobes and swirls into vortexes within them, thus indicating a weak combustion. The fuel entering the energy cell is trapped, for the most part, in the small outer cell, but a small part passes into the larger outer cell where it meets a sufficient quantity of superheated air to explode violently. This explosion produces an extremely rapid rise to high pressure within the steel

energy cell, which blows the main body of the fuel lying in the inner cell back into the main combustion chamber where it meets the main body of air. Here, owing to the shape of the chamber, it swirls around at an exceedingly high rate of turbulence, thus burning continuously as it issues from the energy cell. Owing to the restriction of the two venturis connecting the energy cells, the blowback of fuel into the combustion chamber is controlled so that this operation consumes an appreciable period of time, producing a prolonged and smooth combustion in which the rate of pressure rise on the piston is gradual.

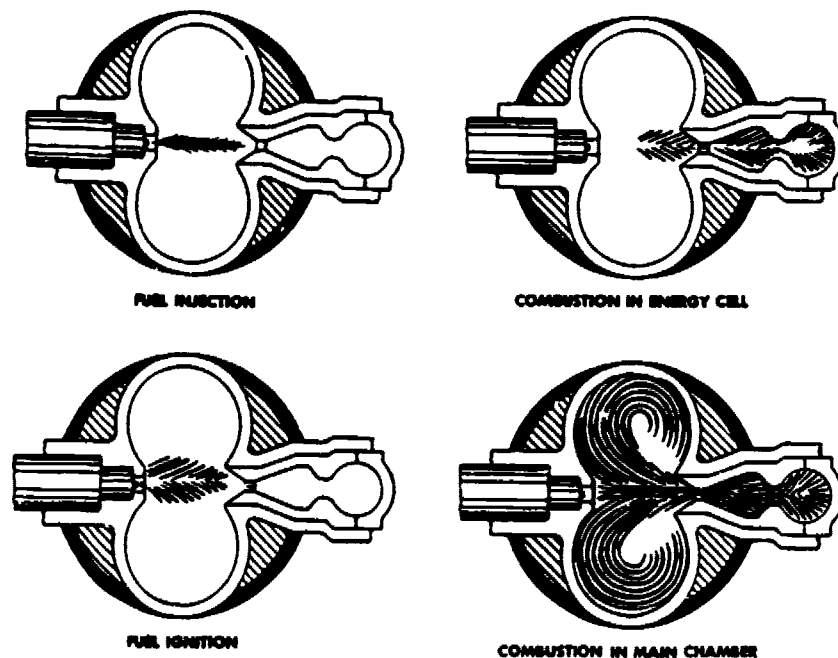

Figure 7. Lanova divided chamber - fuel combustion.

k. Fuel injection principles.

(1) Methods. There are two methods of injecting the fuel against the air pressure in the cylinder of a diesel engine: air injection, where a blast of air from an external source forces a measured amount of fuel into the cylinder; and solid injection, where the fuel is forced into the cylinder by a direct pressure on the fuel itself. The discussion which follows will be limited to those systems utilizing solid injection, because the air injection system has been proved impractical for automotive installations.

(2) Fuel atomization and penetration. The fuel spray entering the combustion chamber must conform to the shape of the chamber so that the fuel particles will be well distributed and thoroughly mixed with the air. The shape of the spray is determined by the degree of atomization and penetration produced by the orifice through which the fuel enters the chamber. "Atomization" is the term used to denote the size of the drops into which the fuel is broken; whereas, penetration is the distance from the orifice which an oil drop attains at a given phase in the injection period. Roughly speaking, the penetration of a spray depends on the length of the nozzle orifice, the diameter of the orifice outlet, the viscosity of the fuel, and the pressure on the fuel. Penetration increases with the increasing ratio of the length of the orifice to its diameter; atomization, however, is increased by decreasing the ratio of the length of an orifice to its diameter. Since

64

penetration and atomization are mutually opposed to each other, a compromise is necessary if uniform fuel distribution is to be obtained. The amount of pressure required for efficient injection is dependent on the pressure of the air in the combustion chamber, the size of the orifice, the shape of the combustion chamber, and the amount of turbulence produced in the combustion space.

(3) Function of injection system. The function of each system is to meter the fuel accurately, deliver equal amounts of fuel to all cylinders at a pressure high enough to insure atomization, and control the start, rate, and duration of injection.

3. MULTIFUEL ENGINES.

a. General.

(1) No matter how a barrel of crude oil is refined, one of the major end products is gasoline. The requirements of the Armed Forces and internal transport will govern the total quantity of middle distillate fuel that will be available. In addition, the extreme demand by these services for middle distillates and heavier fuels makes it evident that gasoline is the only fuel that will be in long supply. Therefore, it is not only desirable but necessary that the engines of ground vehicles that operate on middle distillates must also be capable of burning this readily available hydrocarbon.

(2) Compression ignition engines that will run on gasoline can also become engines that will run on fuels of higher cetane. An engine that will operate over a workable fuel spectrum will enable our Armed Forces to fight anywhere in the world on fuels shipped from the continental United States, from its allied producing areas, and on fuels available in the area of action itself.

(3) The reason the military has a need for multifuel type engines is due to the logistical problem. It is well known that military operations in any area of the world will involve a large amount of automotive equipment. The fuel required to keep the equipment running is enormous, and the transportation of this fuel is a great problem. The burden of transporting the required fuel would be greatly eased if engines would do the following:

(a) Utilize all available fuel in the range from medium octane gasolines through middle distillates. This would vastly increase the amount of usable fuel available to automotive vehicles.

(b) Operate efficiently on any fuel that is available in their area of operation.

(c) Give better fuel economy than existing powerplants.

(4) The multifuel engine is the only powerplant concept that will have the omnivorous but restrained appetite needed to meet these requirements.

b. Requirements. A multifuel engine is defined as an engine that meets the following Army requirements:

(1) The engine must operate on all types of fuel without manual adjustment.

(2) It must start and operate at temperature ranges from -25° F to $+115^{\circ}$ F without off-engine auxiliary equipment.

OS 607, 3-P14

73

(3) It must develop full engine power output on any fuel (proportional only to the specific heat of each fuel).

(4) The engine cooling system package must weigh no more than 6 pounds per horsepower developed.

c. Development.

(1) The initial step in developing a multifuel engine was selecting the type of engine that could best be converted. The first engine examined was the one used most extensively by the Army--the gasoline engine. This engine was readily eliminated for the following reasons:

(a) Gasoline engines operate on high octane, highly volatile fuels, which can only be produced from a small area of the available fuel spectrum.

(b) Fuel economy in gasoline engines is still poor, even with the much publicized gasoline injection system. Since shipping of fuel (which exceeded 50 percent of all supplies shipped in World War II and the Korean Conflict) is strictly a logistical problem, gasoline engines are not economically practicable.

(2) The diesel engine was selected because it is an internal combustion engine like those previously discussed. It requires air, fuel, and ignition.

(3) Other engines, such as the gas turbine and free piston engines, are truly multifuel engines. Gas turbines show much promise and development programs are being conducted in the 600-horsepower and 300-horsepower range. These turbines are expected to approach diesel engine fuel economy at part and full loads.

d. Reasons for selecting the diesel engine for conversion to a multifuel engine.

(1) First, there are intake and exhaust valves on each engine. The diesel engine uses an injector pump and/or a nozzle instead of a carburetor and does not employ spark plugs. Ignition in diesel engines is attained by compressing the air in the cylinder to a point where its temperature is greater than the self-ignition temperature of the fuel and, then, injecting fuel into the high temperature air where it ignites and burns. The expansion as a result of the burning fuel-air mixture produces the energy required to accomplish work. It is an established principle that as the compression ratio of an engine is raised, the efficiency increases accordingly. This means that more power can be obtained from the same amount of fuel. The economy of a diesel engine in comparison to an electrical ignition engine is therefore well established. Experiments have also proven that diesel engines will operate on such fuels as kerosene and JP-4.

(2) Selection of the diesel engine for application to the multifuel principle still left certain unsolved problems.

- (a) Should the engine be air-cooled or liquid-cooled?
- (b) Should the open chamber or auxiliary chamber be used?
- (c) Should the 2-cycle or 4-cycle principle be used?
- (d) How should control of combustion be maintained?
- (e) How could fuel system efficiency be maintained?



66

e. US Army multifuel engine. The engine adopted by the US Army was developed by Continental Motors.

(1) The engine manufacturers adopted the MAN "Controlled Evaporation" principle. This combustion process was developed by Dr. Meurer, of Germany, as a result of his study of the reaction of kinetics involved in the diesel combustion process.

(a) This combustion principle, which Continental calls hyper-cycle, differs from that of most other systems where the fuel is sprayed directly into the air in the combustion chamber. In this system, fuel is sprayed on the walls of the spherical combustion chamber in the direction of the air swirl (fig 8). Through the use of a special intake port, the induction air is given a swirling motion which persists into the combustion chamber and continues to supply oxygen to the slowly evaporating fuel. A small portion of the fuel, about 5 percent, breaks away from the jet before it hits the surface. This 5 percent goes through the normal ignition lag and combustion just as in a diesel engine. The remainder of the fuel, lying on the relatively cool piston and moving with the air, evaporates at a slower rate. It forms a combustible mixture whose composition has a higher self-ignition temperature than those mixtures formed by the same fuels when subjected to rapid evaporation in the presence of excess oxygen, as occurs in the normal diesel.

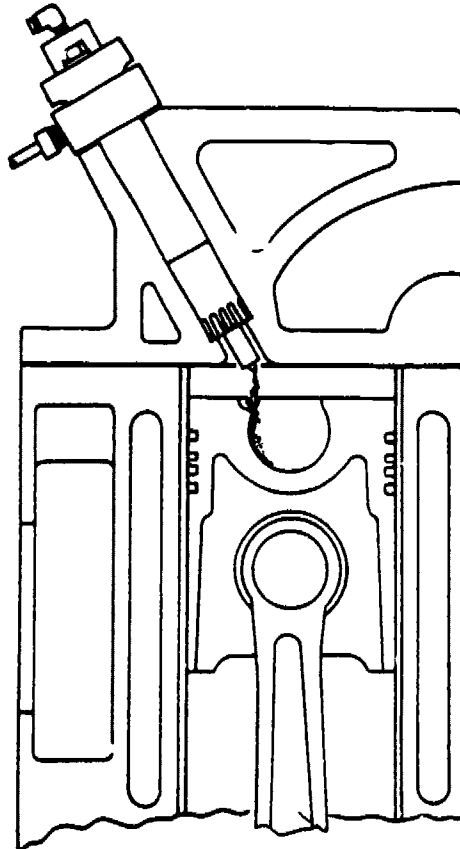

FUEL DEPOSITED ON WALLS OF THE SPHERICAL COMBUSTION CHAMBER INSTEAD OF SPRAYED INTO AIR SPACE.

Figure 8. Start of injection.

607. 3-P16

67

(b) Since this mixture has a higher self-ignition temperature it will not auto-ignite, but must be ignited by the initial 5 percent of the fuel which is burning. Only the portion that is vaporized at any interval will burn, and this quantity of fuel is never large enough to produce high pressure rises.

(c) The burning of the fuel as evaporation takes place prevents accumulation of large amounts of vaporized fuel so that knocking does not occur on low cetane gasoline.

(d) Since the ability of any diesel engine to ignite fuel is dependent upon the compression temperatures, it is important that certain minimum operating temperatures are maintained during light load and idle conditions, especially for arctic operation. For this reason, a water-jacked intake manifold maintained at a minimum of 150° F, by the water temperature thermostat, is used to increase induction-air temperatures in cold climates.

(e) Starting ability without outside aids in temperatures of -25° F is an essential requirement of military vehicles; therefore, an intake manifold flame heater is a standard item on this engine. Fuel, which is sprayed into the intake manifold by a special nozzle and ignited by a spark plug, burns a small portion of the oxygen in the induction system while the engine is being cranked. Induction air temperatures of approximately 300° F are obtained during cranking with the flame heater operating, allowing successful starts down to temperatures of 40° below zero.

(2) The LDS-465-1 engine (fig 9 and 10) is a 4-cycle, in-line, 6-cylinder, overhead valve, turbocharged, liquid-cooled, compression-ignition engine rated at 210 horsepower at 2,800 RPM. It will operate successfully on diesel fuel, compression ignition fuel, or regular gasoline with no modification or adjustment necessary when changing grades of fuel. This engine was developed to power the Army 5-ton wheeled vehicle. It is also a hypercycle multifuel engine that operates on a compression ignition 4-cycle diesel principle, similar to the 4-cycle diesel and gasoline engines. A fuel density compensator is provided as a part of the fuel injector pump to automatically maintain constant full power, regardless of the type or mixtures of fuel being used in the engine. Mechanically, this 4-cycle, compression-ignition engine and the gasoline engine are alike in respect to internal moving parts.

(a) Intake stroke. Air is forced into the cylinder through the open intake valve by atmospheric pressure during cranking, or by the turbocharger during engine operation. The intake passage, in the intake manifold and valve port opening, is designed to produce an air swirl in the cylinder as the air enters the combustion chamber during the intake stroke of the piston.

(b) Compression, injection, and power stroke. On the upward movement of the piston the air swirl continues, which raises the compressed air temperature to between 900° and 1,000° F. Near the top of the compression stroke, fuel is injected by the fuel injector nozzle. A small amount (about 5 percent) of injected fuel is deposited as a thin film on the walls of the spherical combustion chamber in the head of the piston. This small amount of fuel charge is atomized into the airspace in the spherical combustion chamber, which is located in the head of the piston, and functions as a spark plug for the rest of the charge. During the ignition delay period, the main portion of the charge is exposed to a temperature below its cranking temperature and is undergoing precombustion reactions.

OS 607, 3-P17

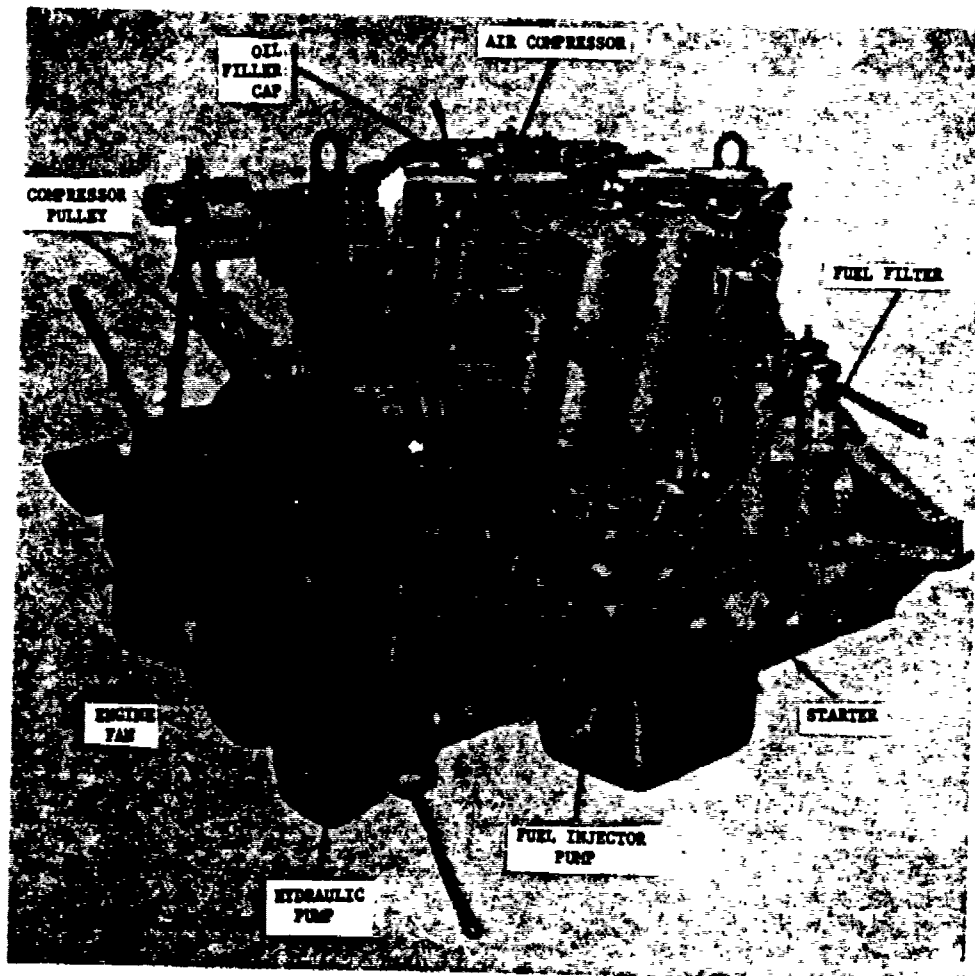

Figure 9. LDS-465-1A engine assembly--3/4 left front view.

(3) The main portion of the charge is progressively vaporized and swept off the combustion chamber wall by the high velocity rotary air swirl. The air swirl was generated during the intake stroke. The vaporized fuel burns smoothly in the spherical combustion chamber as it is swept progressively from the wall by the air swirl over a period of time.

(4) Any following successive portions of fuel will undergo the same sequence of events as they are spread first upon the spherical combustion wall, then are gradually removed in a vaporized form by the combined action of the air swirl and heat of the fire already in progress in the spherical combustion chamber. The air swirl continues to remove only the upper surface of the deposited fuel for the combustion expansion throughout the power stroke of the piston, thus maintaining even combustion and eliminating detonation knock.

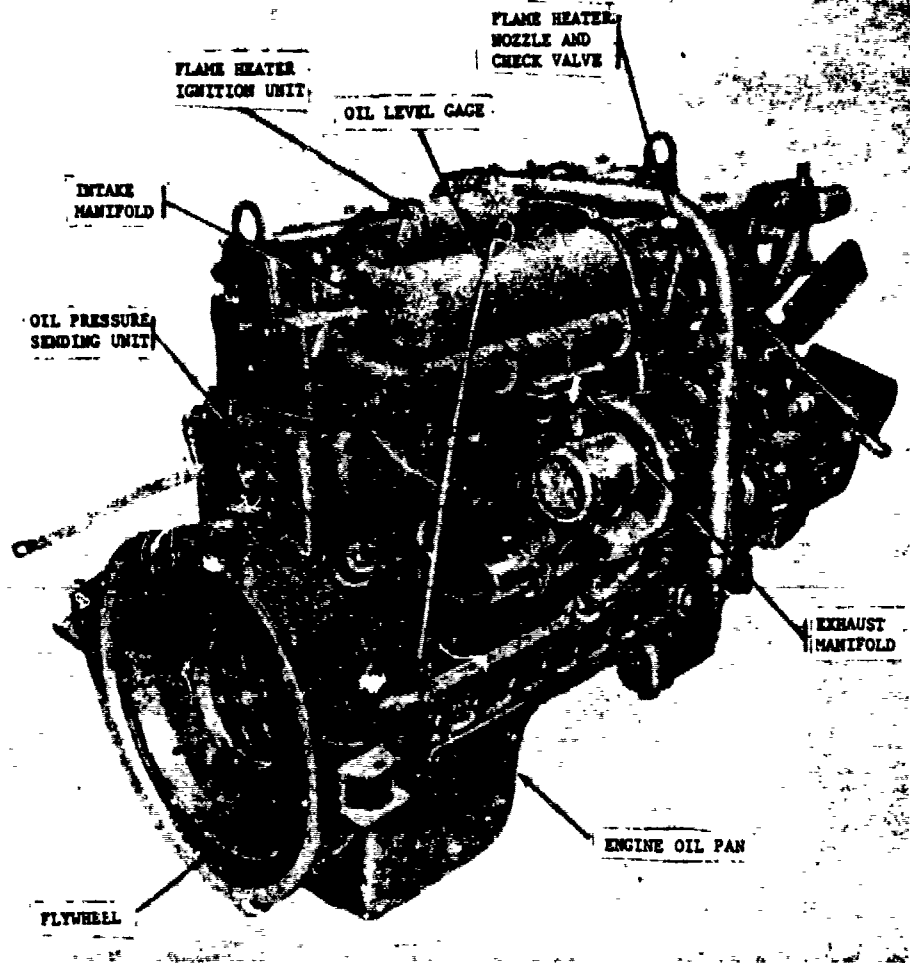

Figure 10. LDS-465-1A engine assembly--right rear view.

(c) Exhaust stroke. The exhaust stroke is the same as in the conventional diesel engine. The piston is pushed up through the cylinder by the crankshaft, forcing the exhaust gases out of the cylinder through the exhaust valve port which is timed to open on the exhaust stroke.

f. At present, there are conclusive tests to indicate how Continental solved the fuel efficiency problem. The best test of how multifuel capacity is built into an engine is to compare its performance on several fuels. Compared with a standard spark ignition engine, the LDS-465 was more efficient burning gasoline, JP-4, and diesel fuel. Also, since gasoline has approximately 12 percent less heating value than diesel, this engine was actually more efficient on gasoline than it was on diesel fuel. This, then, is further evidence of the sacrifice in optimum diesel performance that had to be made to obtain multifuel capacity.

g. In conclusion we have seen that multifuel capacity can be built into compression-ignition engines by taking the necessary measures to maintain combustion control and fuel system efficiency on all fuels. Other design problems and Army requirements, such as lubrication, heat rejection, component life, fuel economy, and operation in extreme temperatures, are solved by conventional methods.

4. PRINCIPLES OF MULTIFUEL ENGINES.

a. General. The multifuel engine is fundamentally a 4-cycle diesel engine with a special combustion chamber shape which enables it to operate on a variety of fuels.

b. Chamber. The combustion chamber of the multifuel engine is basically a diesel engine open combustion chamber with a special piston as shown in figure 11. The piston has a cavity in its top which is roughly spherical in shape. This special shaped piston promotes even combustion for a wide variety of fuels - from low grade diesel fuel to highly volatile gasoline.

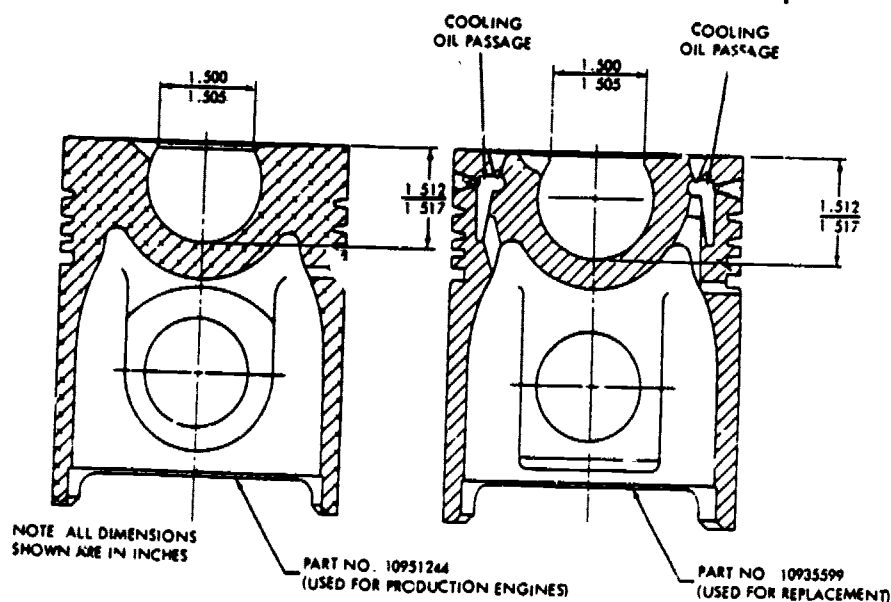

Figure 11. Piston shapes.

c. Porting. To help accomplish this controlled combustion on a wide variety of fuels, a swirling action of the air in the cylinder is induced by the intake port shape (fig 12 and 13).

d. Sequence. As the piston nears the top of the compression stroke, fuel is injected into the cylinder in liquid form. A small amount of the injected fuel is deposited as a thin film on the walls of the spherical combustion chamber in the head of the piston (fig 14). This small amount of fuel charge is atomized into the airspace in the spherical combustion chamber in the head of the piston and functions as a spark plug for the remainder of the charge. During the ignition delay period, the main portion of the charge is exposed to a temperature below its cracking temperature and is undergoing precombustion reactions. The main portion of the charge is progressively vaporized and swept off the combustion chamber wall by the high velocity rotary air swirl that was generated during the intake stroke. This vaporized

71

fuel burns smoothly in the spherical combustion chamber over a period of time. The air swirl continues to remove only the upper surface of deposited fuel for combustion expansion throughout the power stroke of the piston, thus maintaining even combustion and eliminating detonation knock.

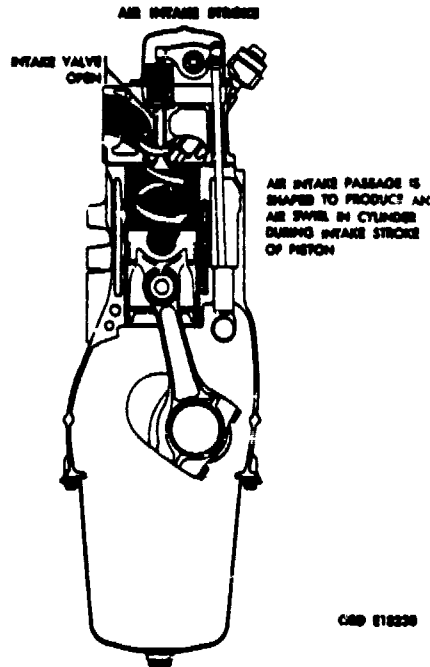

Figure 12. Air intake stroke.

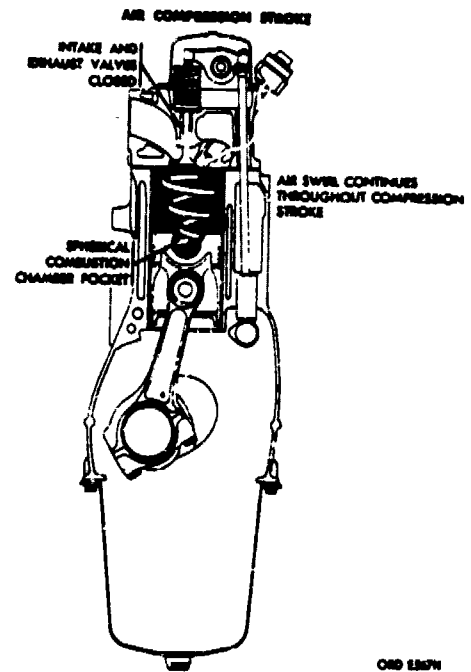

Figure 13. Air compression stroke.

5. COMPONENTS OF MULTIFUEL ENGINES.

a. Fuel density compensator.

(1) In the early models of the multifuel engine, the power output varied greatly with the fuel being used. To alleviate this situation, a device known as a fuel density compensator was developed. With this unit installed on the multifuel engine, the power output is the same regardless of the fuel or combination of fuels used.

(2) Let's take a brief look at how the fuel density compensator works. The fuel enters through a pressure regulating valve. As the fuel passes the valve, it flows through a viscosity/density sensitive orifice. This orifice is nothing more than a piston loosely fitted into a cylinder. The fuel acts on the spring-loaded piston which adjusts the high speed limiting stop on the governor through linkage. The greater the density of the fuel, the greater effect on the high speed limiting stop.

b. Intake manifold flame heater. Another unit which is unique to the multifuel engine is the intake manifold flame heater. The reason for this heater is to raise the temperature of the incoming air to the proper level for cold weather starting and warmup. The flame heater assembly consists of a housing, spark plug, and spray nozzle. The spark plug is powered by the flame heater ignition unit, which is mounted on the intake manifold elbow. The nozzle sprays fuel under pressure into the intake manifold elbow assembly. The fuel vapor is ignited by the spark plug and burns in the intake manifold, thus heating the air before it enters the engine combustion chambers.

OS 607, 3-P21

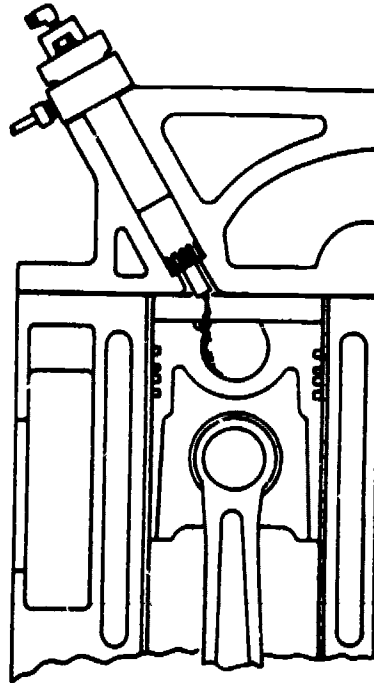

FUEL DEPOSITED ON WALLS OF THE SPHERICAL COMBUSTION CHAMBER INSTEAD OF SPRAYED INTO AIR SPACE.

Figure 14. Start of injection.

c. Oil cooling nozzles. Due to the various types of fuel this engine can operate on, its effective operation depends upon proper piston operating temperature. Oil to cool the pistons is conveyed through an individual oil gallery and directed to the inside of the piston skirts by six oil cooling nozzle assemblies--one for each piston. The oil flow to the nozzles is controlled by a 15 PSI minimum pressure control valve.

6. GAS TURBINE ENGINES.

a. General.

(1) For the purpose of evaluating the adaptability of gas turbines to military vehicles and to determine the advantages and disadvantages of such installations, the Army obtained a number of gas turbines to test in military vehicles.

(2) One of the major advantages of the gas turbine as opposed to the standard internal combustion engine is that its weight and bulk per unit of horsepower output is lower. Also, this engine can operate on a wide range of hydrocarbon fuel and maintain high torque at stall speeds.

(3) The first of these units that was procured for testing in an Army vehicle was the GMT-305 gas turbine engine. This turbine is commercially available and is a regenerative-type free turbine with a rating of 206 horsepower at 3,350 RPM at an ambient temperature of 80° F and 328 pound-feet of torque at the same speed.

b. Principles of operation. The engine principles described thus far in this subcourse pertain to reciprocating engines. Reciprocating motion, as has been mentioned earlier, is an up-and-down or back-and-forth motion. The conventional gasoline and diesel engines use this reciprocating motion of the piston to turn the crankshaft. This principle you already understand.

(1) The principle of the turbine engine is somewhat different as the motion is rotary or circular; i.e., no up-and-down or back-and-forth motion is required. In the reciprocating engine, the up-and-down or back-and-forth motion is changed to a rotary or circular motion through the crankshaft. In the turbine, this circular motion is direct. Water and steam turbines have used this principle for a long time. The gas turbine is comparatively new, but it is becoming increasingly important.

(2) The gas turbine engine has no pistons or connecting rods, and no water is required for its operation. In this turbine, fuel is burned in a chamber into which air has been pumped by an air compressor. This burning fuel and air creates a high temperature and the greatly expanded gases rush through the turbine. The whirlwind of the hot gases rushing through the turbine produces power. This is similar to the wind turning a windmill. The turbine is a wheel with vanes or blades (fig 15) which are somewhat like the blades of an ordinary fan. The push of the hot gases against these vanes causes the turbine wheel to turn and power is produced, which may be in the form of direct power from a shaft through reduction gears that are turned by the turbine wheel. (Figure 16 illustrates this type but the compressor and turbine details are omitted.)

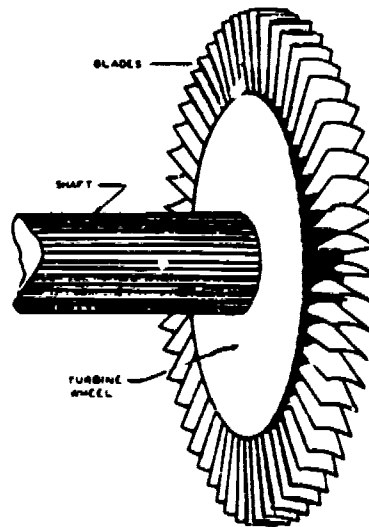

Figure 15. Turbine wheel.

(3) The power may be in the form of compressed air produced by the compressor. (The compressor itself is powered by the turbine.) In this system some of the compressed air is necessary to support combustion, but the excess amounts may be used for power.

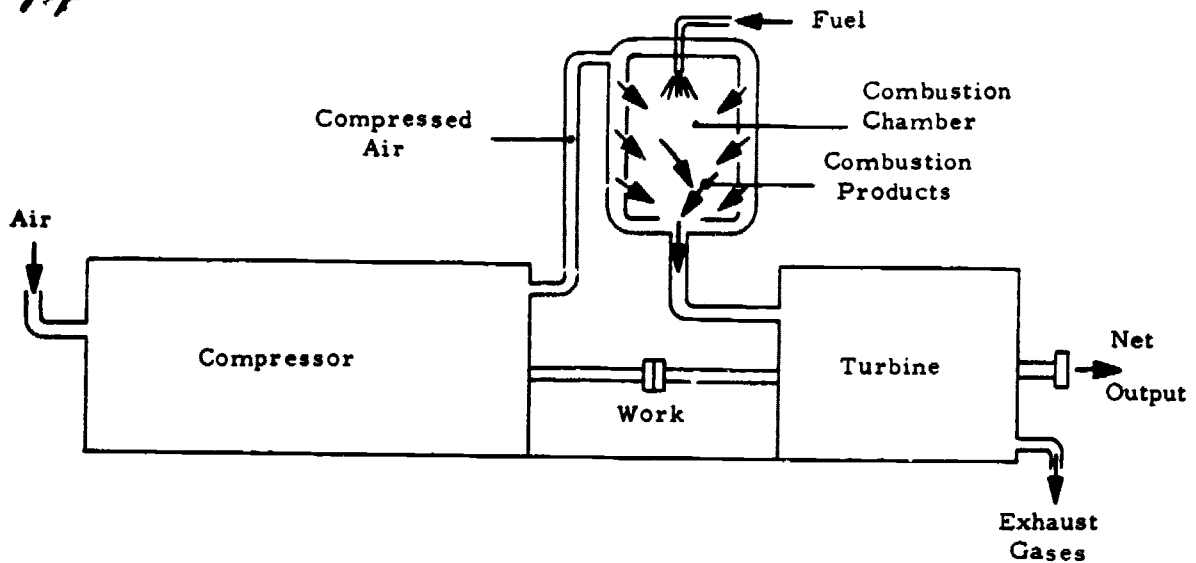

Figure 16. Schematic drawing of a gas-turbine engine.

(4) Any gas turbine consists basically of an air compressor (or compressors), a combustion section, and a turbine (or turbines). The engine functions by taking in atmospheric air and compressing it. Fuel is burned in the compressed air (fig 17) and the gases expand through a turbine wheel to drive the compressor. In some turbines, the power obtained is entirely through the shaft turned by the turbine; in others, power is in the form of air. All air excessive to the needs of the compressor is bled off. In the turbojet aircraft, the power is derived from the ejection of the gases in jet form. The gas turbine for ground use can be designed to burn almost any solid, liquid, or gas containing heat energy, provided the gases of combustion do not corrode or place deposits on the turbine parts. Gas turbine engines do not have the problem of fuel knock or ignition timing. The main difficulty with combustion in the gas turbine is keeping the temperatures of the gases which are delivered to the turbine down to a point that the turbine can tolerate.

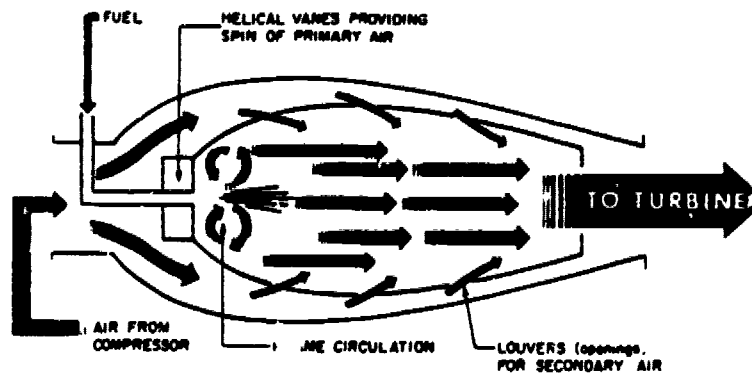

Figure 17. Gas turbine combustion chamber.

c. The GMT-305 gas turbine engine.

(1) The GMT-305 gas turbine is cooled by air and can operate on gasoline, diesel fuel, or kerosene. This engine is 36 inches long, 31 inches wide, and 26 inches high, and its dry weight is about 650 pounds. The present rated specific fuel consumption at full load is 0.57 pound of fuel burned per brake horsepower per hours.

(2) An explanation of the way in which the GMT-305 operates is best made by reference to the numerals shown in figure 18, which is a cutaway diagram of the GMT-305 gas turbine.

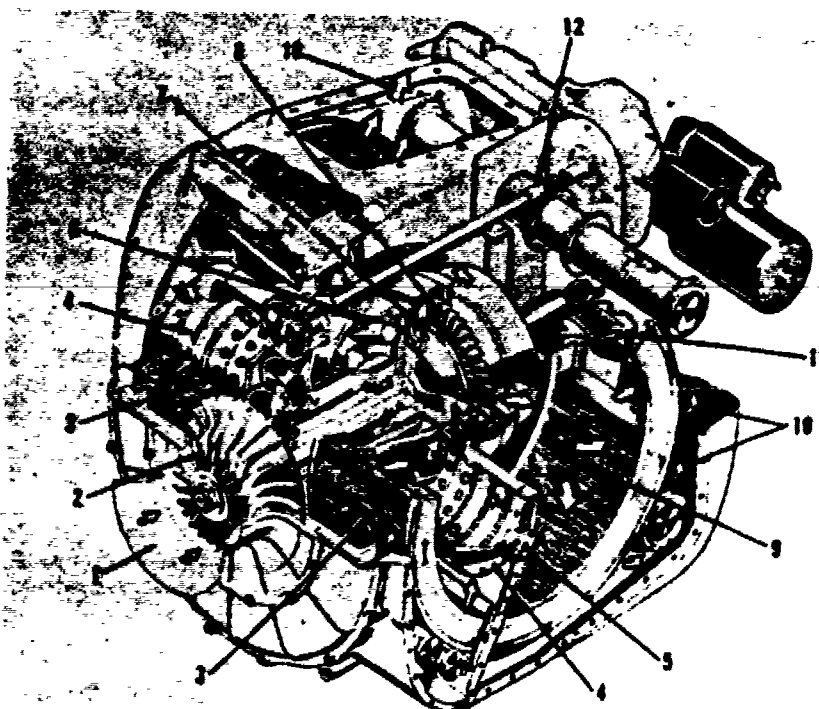

Figure 18. Cutaway diagram of GMT-305 gas turbine.

- (a) No 1 - Atmospheric air enters the air inlet.
- (b) No 2 - The air is compressed by the axial-flow compressor to above three atmospheres of pressure.
- (c) No 3 - Rotating regenerators furnish heat to the compressed air as it passes through them.
- (d) No 4 - The heated, compressed air enters the combustors.
- (e) No 5 - Fuel is injected through nozzles into the combustors.
- (f) No 6 - Gases resulting from the combustion of the fuel and air pass through the turbine vanes.
- (g) No 7 - These gases first drive the "gasifier turbine," which powers the air compressor.

OS 607, 3-P25

76

(h) No 8 - The gases then drive the power turbine (note that the gasifier turbine and the power turbine are not connected mechanically).

(i) No 9 - The hot gas exhausted from the power turbine is cooled by the rotating regenerators.

(j) No 10 - Exhaust gas at 300° to 500° F is directed out of the exhaust ports.

(k) No 11 - The power output shaft is driven from the power turbine through a single-stage reduction gear.

(l) No 12 - The accessory drive shaft is driven by the gasifier turbine through a set of reduction gears.

(3) Essentially, the gas turbine operates on the Joule cycle. This is the principle in which atmospheric air is compressed adiabatically (occurring without gain or loss of heat; a change of properties, such as volume and pressure of the contents of an enclosure; without exchange of heat between the enclosure and its surroundings), the combustion process adds heat at constant gas pressure, and the gases are expanded adiabatically through the turbine blades.

(a) The function of the regenerator is to recover heat from the turbine exhaust to improve efficiency.

(b) The rotating regenerators of the GMT-305 engine reduce exhaust noise, so that no muffler is required, and they also cool the exhaust gas.

(c) Neither radiator, fins, fans, nor plumbing is necessary for cooling the powerplant.

(d) Because the power turbine is connected pneumatically and not mechanically to the gasifier turbine and the air compressor, the power turbine acts as a built-in torque converter and maximum torque occurs when the power turbine is stalled.

(4) A GMT-305 gas turbine was installed in a modifier, 90mm, full-tracked, self-propelled gun M56 and tested during the winter months at the US Army Climatic Test Station, Fort Churchill, Canada.

(a) During a total of 1,110 vehicle miles and 110 turbine hours, there were no major breakdowns, and 36 cold starting tests were successful. The formation of ice in the fuel lines was avoided by adding a pint of alcohol to each 20 gallons of fuel.

(b) These tests disclosed that a GMT-305 turbine equipped military vehicle would require unusually durable brakes to withstand continuous operation at various conditions of speed and torque.

1. This requirement is the result of inherent characteristics of the GMT-305 powerplant. Whereas the acceleration or deceleration of the vehicle is controlled by changing the speed of the power turbine, the accelerator of the vehicle that regulates the rate of fuel flow to the combustors also controls the speed of the gasifier turbine.

2. Since the two turbines are only pneumatically connected, the speed of the output shaft of the power turbine is not regulated directly by the accelerator, and there is a consequent delay between movement of the accelerator and change in speed of the output shaft.

OS 607. 3-P26

3. During the tests in extreme cold climate, it was found necessary to maintain the speed of the gasifier turbine at no less than 20,000 revolutions per minute for the best performance. Therefore, while applying the brakes to decelerate the vehicle, it was necessary to keep the accelerator depressed sufficiently to keep the gasifier turbine in the satisfactory range of performance of 20,000 revolutions per minute or more.

EXERCISE

- 26. In a comparison of the 2-stroke- and 4-stroke-cycle diesel engines, which statement is TRUE?
 - a. The availability of air to the 4-stroke-cycle engine during intake is less
 - b. The effective power stroke of the 4-stroke-cycle engine is longer
 - c. The effective power stroke of the 2-stroke-cycle engine is longer
- 27. Fuel is injected directly into the combustion space at the top of the cylinder on which type of combustion chamber?
 - a. Precombustion
 - b. Open
 - c. Turbulent
- 28. To comply with Army requirements, what is the maximum weight of the engine cooling system package allowed in pounds per horsepower in a multifuel engine?
 - a. 6
 - b. 10
 - c. 12
- 29. The gasoline engine was eliminated during the selection of a multifuel test engine because
 - a. it was too difficult to maintain.
 - b. of excessive maintenance costs.
 - c. of poor fuel economy.
- 30. Which is an accepted principle of internal combustion engines?
 - a. Spark ignition engines are more efficient than compression ignition engines
 - b. Normally aspirated engines burn fuel more completely during the combustion process
 - c. Engine efficiency increases proportionately with increased compression ratios
- 31. What is done in engines operating on the hypercycle principle that differs from engines operating on other injection system principles?
 - a. The fuel is sprayed into the center of the compressed air
 - b. The fuel is sprayed onto the walls of the combustion chamber
 - c. The fuel and air are mixed before injection
- 32. What is the function of the 5 percent of fuel that breaks away from the main charge during injection in the multifuel engine?
 - a. To ignite the main charge
 - b. To speed up ignition lag
 - c. To provide ignition advance

78

33. What prevents the multifuel engine from knocking when burning low cetane gasoline?
- The mechanical ignition lag of 8°
 - The gradual burning of evaporated fuel
 - The rapid induction of heated air
34. The basic engine upon which the multifuel engine was developed is the
- 4-cycle gasoline.
 - 2-cycle diesel.
 - 4-cycle diesel.
35. Which phrase describes the shape of the top of the multifuel piston?
- Two "eyebrow" valve reliefs
 - The piston is flat topped
 - The configuration is roughly spherical
36. The swirl in the cylinders of the multifuel engine is induced by the
- piston shape.
 - shape of the intake port.
 - supercharger.
37. What is an advantage of the gas turbine engine over the standard internal combustion engine?
- It is more reliable
 - It burns less fuel
 - It can deliver high torque at stall speeds
38. What heats the compressed air in the GMT-305 gas turbine engine?
- Manifold heater
 - Regenerators
 - Compressor
39. The purpose of the fuel density compensators is to regulate the
- governor.
 - power output of the engine.
 - flow of fuel.
40. Which is a function of the regenerators in the GMT-305 engine?
- To assist in compressing the intake air
 - To cool the exhaust gases
 - To drive the gasifier turbines

79

CORRESPONDENCE COURSE
of the
US ARMY ORDNANCE
CENTER AND SCHOOL



LESSON ASSIGNMENT SHEET

<u>Ordnance Subcourse No</u> 607.	Engine Principles
<u>Lesson 4</u>	Engine Lubricating Systems
<u>Credit Hours</u>	Three
<u>Lesson Objective</u>	After studying this lesson you will be able to discuss the principles of lubrication, types of engine lubricating systems, military lubricants and lubrication, and effects of weather on lubricating oils.
<u>Text</u>	Attached Memorandum
<u>Materials Required</u>	Answer sheet and exercise response list
<u>Suggestions.</u>	None

STUDY GUIDE AND ATTACHED MEMORANDUM

1. **GENERAL.** It may well be said that a modern mechanized army travels on a film of oil. The importance of proper lubrication of vehicles cannot be overstressed. The all-vital essentials of most military vehicles are oil, fuel, and water. Of these three, the lack of oil could be the most damaging to a vehicle engine. However, adequate lubrication cannot be assured by simply maintaining the proper oil level. Proper lubrication requires that all the lubricating system components are in proper working order and that a proper grade of oil is used.

2. **FUNDAMENTALS OF LUBRICATION.**

a. **General.** Lubrication is the act of applying lubricants and lubrication substances which are capable of reducing friction between moving mechanical parts. Since modern materials are designed to utilize lubrication for obtaining proper functioning, it is a most vital type of preventive maintenance.

b. **Definition of friction.** All surfaces, no matter how smooth they may appear to the unaided eye, are rough and uneven when sufficiently magnified. Friction is the resistance to relative motion between two bodies in contact. This resistance or drag between the surfaces of bodies in contact retards or prevents them from moving in relation to one another. When vehicle brakes are applied, the friction between the surfaces of brakedrums, which are attached to the vehicle wheels, and the surfaces of linings on the brakeshoes, which are fastened to the axle housings, retards movement of the wheels. When a clutch is engaged, the frictional drag existing between the driving surface and the driven surface prevents these surfaces from slipping

OS 607, 4-P1
December 1975



and makes them move together as a unit. Friction absorbs power and generates heat in proportion to the amount of effort required to overcome it. For example, when a sled is drawn over dry pavement friction occurs between the runners and the ground, drag is apparent, and the sled runners will be warm, indicating that heat has been generated.

c. Types of friction.

(1) Friction of rest and friction of motion. Before any body at rest can be moved, sufficient force must be applied to overcome its inertia and the friction between it and the surface with which it is in contact. This is static friction or friction of rest. After the body is once in motion, it can be kept in motion by expending sufficient energy to overcome the friction between it and the surface with which it is in contact. This is kinetic friction or friction of motion. Static friction, which must be overcome in order to put any body in motion, is greater than the kinetic friction that must be overcome to keep the body in motion after it is started.

(2) Sliding friction. Sliding friction results when the surface of one solid body is moved on the surface of another solid body.

(3) Rolling friction. Rolling friction results when a curved body, such as a cylinder or sphere, rolls upon a flat or curved surface. In his early existence, man discovered that if rollers or wheels were used a considerable part of the force necessary to move objects against sliding friction was eliminated; thus rolling friction was utilized to save labor.

(4) Fluid friction. Man also discovered, in his early existence, that the force required to overcome fluid friction was less than the force required to move the same body if either sliding or rolling friction had to be overcome. Fluid friction is the resistance to motion set up by the cohesive action between particles of a fluid and the adhesive action of those particles to the medium tending to move the fluid. For example, if a paddle is used to stir a fluid, the cohesive force between the molecules of the fluid will tend to hold the molecules together, and thus prevent motion of the fluid. At the same time, the adhesive force of the molecules of the fluid will cause the fluid to adhere or stick to the paddle and create friction between the paddle and the fluid.

d. Cohesion and adhesion.

(1) Definitions. Cohesion is the molecular attraction between like particles throughout a body, or the force that holds any substance or body together. Adhesion is the molecular attraction existing between surfaces of bodies in contact, or the force which causes unlike materials to stick together. From the standpoint of lubrication, adhesion is the property of a lubricant that causes it to stick or adhere to the parts lubricated; cohesion is the property which holds a lubricant together and resists a breakdown of the lubricant under pressure.

(2) Varying degrees. Cohesion and adhesion are possessed by different materials in widely varying degrees. In general, solid bodies are highly cohesive but only slightly adhesive. Fluids, on the other hand, are quite highly adhesive but only slightly cohesive. Generally, a material having one of these properties to a high degree will possess the other property to a relatively low degree. The adhesive property of fluids varies greatly. If mercury, which is highly cohesive and slightly adhesive, is poured over a sloping iron plate, it will run off in drops without adhering to the plate. Water, which has relatively low cohesive and adhesive properties, will not spread out over or adhere to the plate to any great extent and will run off rapidly. Oil, which has higher cohesive and adhesive properties than water, will adhere to the plate, spread out over it to a considerable extent, and will run off slowly.

e. Relation of friction, cohesion, adhesion, and lubrication.

(1) Friction always consumes power and produces heat. The amount of power consumed and heat produced varies with the conditions under which the friction is produced or occurs. To overcome sliding, friction consumes the greatest amount of power and produces the greatest amount of heat. To overcome rolling, friction consumes a lesser amount of power and produces a lesser amount of heat. To overcome fluid, friction consumes the least amount of power and produces the least amount of heat.

(2) Any fluid, when placed between two surfaces, tends to keep the two surfaces apart and to change any sliding friction between them into fluid friction. When two such surfaces are kept apart by such a fluid film, they are said to be lubricated.

(3) The extent to which lubrication reduces the friction between two surfaces is governed by two factors: first, the selection of the fluid which has the best proportion of cohesive and adhesive properties for the particular application; and second, the amount of pressure between the two surfaces. To insure lubrication, the layer of fluid must be kept intact; and the greater the pressure, the more difficult this becomes.

f. Langmuir theory of lubrication.

(1) It is agreed generally that the Langmuir theory offers the best and simplest explanation concerning the possible behavior of a lubricating oil film. According to this theory, a film of oil capable of maintaining a full fluid film between two surfaces in motion is composed of many layers of oil molecules (fig 1).

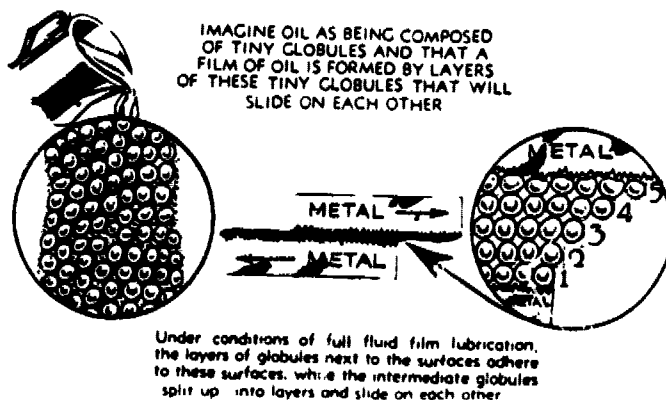

Figure 1. Theory of an oil film.

(2) When two surfaces separated by an oil film are set in motion, the oil film "splits up" into layers of these molecules. One layer slides across the surface of another and in so doing sets the next layer in motion. The layers closest to the surfaces adhere to them, while the intermediate layers cohere to each other (fig 2).

(3) The Langmuir theory also offers an excellent explanation of the varying degrees of lubrication that may appear between two surfaces in motion. Engineers usually recognize three degrees of lubrication. The condition illustrated in item A, figure 3, where there is metal contact and practically no lubrication present, usually is considered to be "insufficient lubrication." A very thin film of lubricant usually is considered "partial lubrication" (B, fig 3), sometimes it is called "boundary lubrication,"

although many bearings operate satisfactorily in this region under certain conditions. "Sufficient lubrication" (C, fig 3), or "full fluid film lubrication," denotes that enough oil is present to establish and maintain a full fluid film between the two moving surfaces. These three degrees of lubrication can be likened to the layers of molecules present; for example, a full fluid film can be visualized as five or more layers, a partial film as three layers, and the insufficient film as less than three layers.

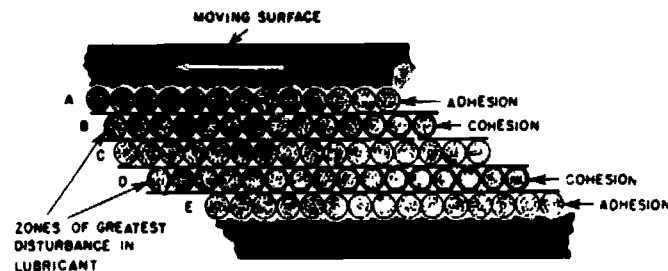

Figure 2. Action of an oil film between two moving surfaces.

g. Oil film and wedge theory. The oil film and wedge theory affects the action of an oil film between a shaft and its bearing. According to this theory, oil molecules adhering to the surface of a rotating shaft are carried along by the motion of the shaft. These molecules drag along the adjacent layer of molecules by the force of cohesion. At the same time the weight of the load on the shaft forces the shaft down into the oil film near the bottom of the bearing. This pressure action narrows the clearance at the lower side of the bearing, causing some of the layers of molecules to be "squeezed" or "wedged" into this space. This wedging action lifts the shaft from the bearing and thus establishes the full fluid lubricating film (fig 4). The wedging action of the oil film in a bearing creates high- and low-pressure areas, the oil supply being introduced at the low-pressure area (fig 5). The positions of the low- and high-pressure areas vary somewhat with the speed of rotation.

h. Viscosity. The degree of cohesion between the molecules of an oil determines its grade or viscosity. The molecules of the more viscous or heavy oils are bound together more firmly than the molecules of the less viscous lighter oils. The behavior of oils of different viscosities in a simple shaft and bearing can be illustrated by the following: too heavy an oil may be visualized as an oil in which the molecules are so large that they cannot wedge themselves between the rotating journal and bearing surface. Too light an oil may be visualized as an oil in which the molecules are either so small that they cannot individually sustain the loads imposed on them, or the force of cohesion between the molecules is not strong enough to hold them together in great enough masses to collectively support the load. The correct oil is that oil which is made up of molecules of the right size and cohesiveness to prevent the shaft, in its rotary motion, from breaking through the molecular layers of the oil film (fig 6).

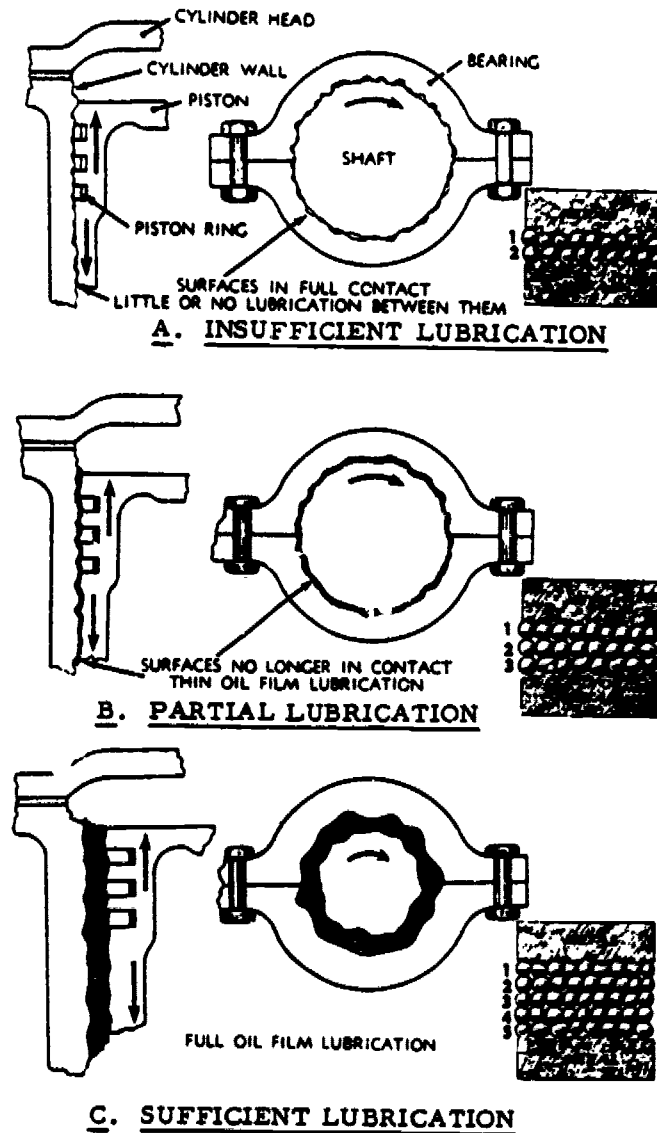

Figure 3. Insufficient, partial, and sufficient lubrication.

1. Fundamental factors influencing the selection of the proper grade of lubricant. There are three fundamental factors which influence the selection of the proper grade of lubricant for any bearing operated under normal conditions. First, the rubbing speed (generally in linear feet per minute); second, the clearance between bearing surfaces; and third, the load in terms of pressure per unit of bearing area (generally pounds per square inch). Obviously, there may be innumerable variations or combinations of these three conditions depending upon factors of outside origin; for instance, high or low temperatures from outside the bearing, heat generated within the bearing, presence of moisture or abrasive dust, presence of contaminating substances, etc. All of these conditions are taken into consideration in selecting the grade of lubricant.

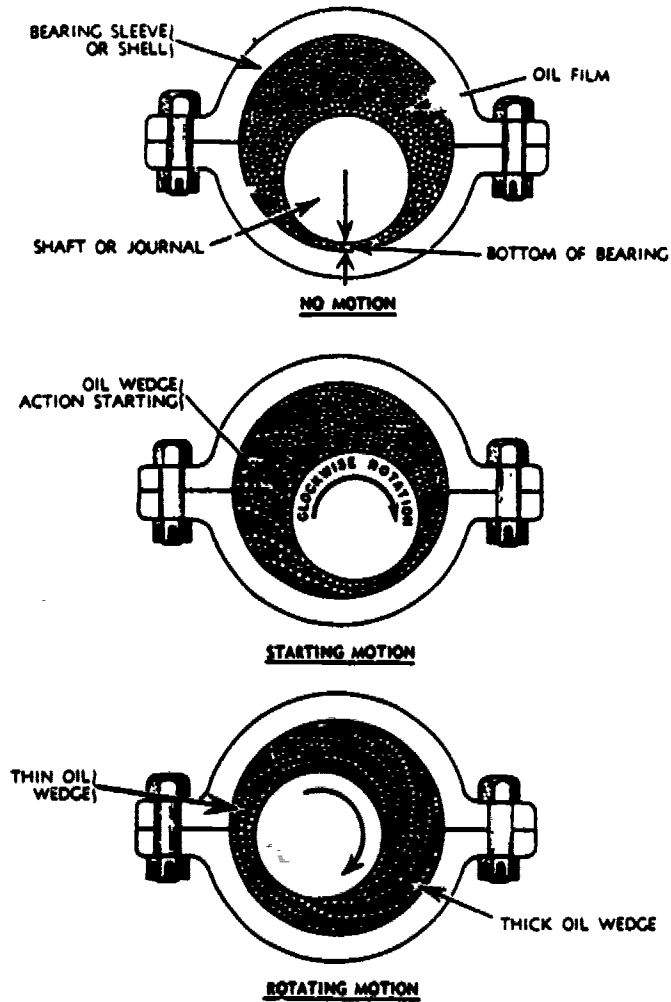

Figure 4. Oil film and wedge theory.

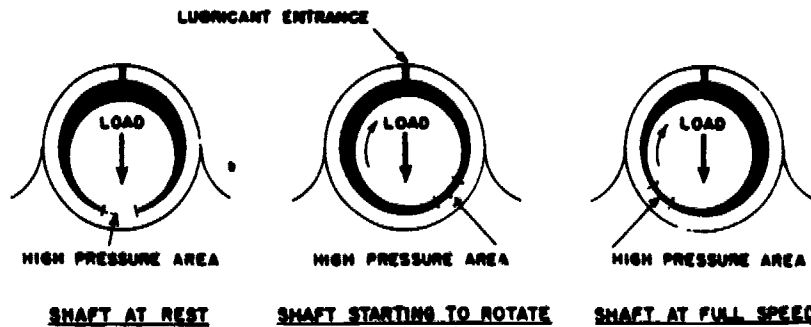

Figure 5. Speed of rotation determines the high- and low-pressure areas.

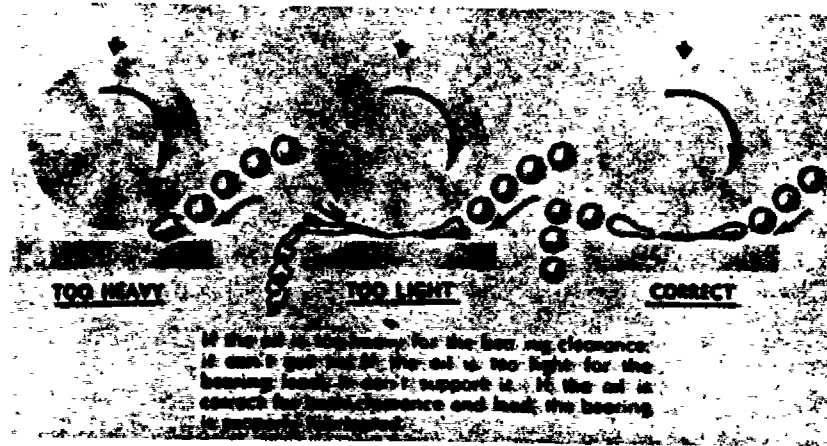

Figure 6. Effect of viscosity.

(1) Rubbing speed. The properties of a lubricant must be such that it will stick to the bearing surfaces and support the load at operating speeds. More adhesiveness is required to make the lubricant adhere to bearing surfaces at high rubbing speeds than at low speeds. At low rubbing speeds less adhesion is required, but, due to the decrease in wedging action, greater cohesion is necessary to prevent the lubricating film from being squeezed out from between the bearing surfaces.

(2) Clearance between bearing surfaces. Other conditions being the same, greater clearance between bearing surfaces requires higher viscosity and cohesiveness in the lubricant to insure maintenance of the lubricating film. The greater the clearance the greater must be the resistance of the lubricant against being pounded out with the resultant destruction of the lubricating film.

(3) Bearing load. Other conditions being the same, a greater unit load on a bearing requires a higher lubricant viscosity if the lubricant film is to be maintained. The cohesion must be sufficient to prevent a breakdown of the lubricating film. A lubricant which initially is too viscous (cohesive) for a given condition of load and speed will absorb more power, convert the power to heat, and automatically reduce its own viscosity to a lower value. Such reduction is at the expense of higher operating temperature and shorter lubricant life.

j. Additional functions of lubricants. In addition to reducing friction, a lubricant usually has one or several of the following functions: to cool machine parts by conduction of generated heat, to remove contaminants, to prevent rust, to absorb or reject air or water, to resist the actions of solvents, to prevent corrosion or solution of certain sensitive metals, to transmit power by hydraulic means, and to prevent scuffing or welding of rubbing surfaces during momentary failure of the lubricant supply. In many cases, lubricants are used solely for their abilities to prevent rust, to transmit power hydraulically, etc.

3. PRINCIPLES OF ENGINE LUBRICATION.

a. Purpose.

(1) Engine lubricating oils have four functions: to prevent metal-to-metal contact in moving parts, to assist in carrying heat away from the engine, to clean the engine parts as they are lubricated, and to form a seal between the piston rings and cylinder walls to prevent blowby of the combustion gases.

(2) The primary function of engine lubrication is to reduce the friction between moving parts. Oils are used to reduce friction, not only because friction uses up power that would otherwise be available to drive the vehicle, but also because friction is destructive and creates heat that can cause moving parts to disintegrate. The greater the friction present between moving parts, the greater the energy required to overcome that friction. This increase in energy merely adds to the heat generated. Moving parts that have been deprived of oil will melt, fuse, or seize after a very short period of engine operation. It is lubrication that makes possible the use of plain bearings or bushings in a modern engine. Cylinders and pistons must be effectively lubricated to prevent burning or seizure. Friction is severe at certain points, particularly along the surfaces of the piston rings where they contact the cylinder walls. Although the crankshaft, connecting rods, piston pin bearings, main bearings, connecting rod bearings, and piston rings are the most important engine lubrication points, there are also many other parts which must have an adequate supply of oil. Valve stems operate under stress and wide ranges of temperatures for long periods of time. Valve tappets and guides must be lubricated, and some gears must be constantly bathed in oil.

(3) The oil is heated through contact with pistons and cylinder walls, after which it drops into the oil pan. The flow of air past the oil pan helps to cool the oil. In some instances where the oil pan is not exposed to a flow of air, it is necessary to add an oil cooling unit.

b. Characteristics of engine oils.

(1) Lubricating oils are designated according to certain characteristics they possess and according to their reaction to certain tests. Oils ordinarily are classified according to their viscosity.

(2) The viscosity of oil refers to its resistance to flow. When oil is hot, it will flow more rapidly than when it is cold. In cold weather, therefore, oil should be thin (low in viscosity) to permit easy flow; in hot weather the conditions should be reversed. The temperature in which the vehicles are to operate determines whether an oil of low or high viscosity should be used. If, for example, a very thin oil was used for hot weather operation the oil would literally burn up, consumption would be excessively high, and the lubricating cushion between the moving parts would be too thin to provide adequate protection. Conversely, in cold weather a heavy oil would not provide adequate lubrication, since the oil flow would be so sluggish that some parts would receive little or no lubrication.

(3) Oils are graded according to their viscosity by a series of Society of Automotive Engineers (SAE) numbers. The Army has standardized its engine oils into three grades: SAE 10, SAE 30, and SAE 50. The higher the SAE number the heavier the oil. This method of designating oils has no connection with the quality of the oil.

(4) Oil does not wear out, but it does become contaminated and diluted. Water, one of the products of combustion, will seep by the piston rings in the form of steam (especially in cold weather) and will condense in the crankcase. This water emulsifies the oil, and, with any dirt or foreign

matter present, forms a sludge that clogs up the oil lines and lubricating passages. Contamination of engine oil is minimized by controlling engine temperatures, by an air cleaner on the carburetor, by oil filters, and by controlled crankcase ventilation.

(5) When lubricating oil becomes diluted with gasoline, some of the lubricating qualities are lost. Excessive use of the choke causes an overrich mixture to be forced into the cylinders. This excess gasoline remains in a liquid state and drains into the crankcase, where it mixes with the oil. When the engine operates at higher temperatures, this condition is corrected because the excess gasoline vaporizes in the crankcase and is carried off through the crankcase breather pipe.

4. TYPES AND COMPONENTS OF ENGINE LUBRICATING SYSTEMS.

a. Types.

(1) General. All important parts of an engine are lubricated (fig 7 and 8) by oil carried in the crankcase. The fact that oil is always present in the crankcase explains why the lubricating system used in most in-line engines is known as a "wet sump system." The "dry sump" is common to radial engines and is sometimes found in the opposed engine. The oil in the in-line engine is circulated under pressure (force-feed) or splashed mechanically on the surfaces to be lubricated. The different methods of circulating the oil are splash, combination splash and force-feed, and full force-feed.

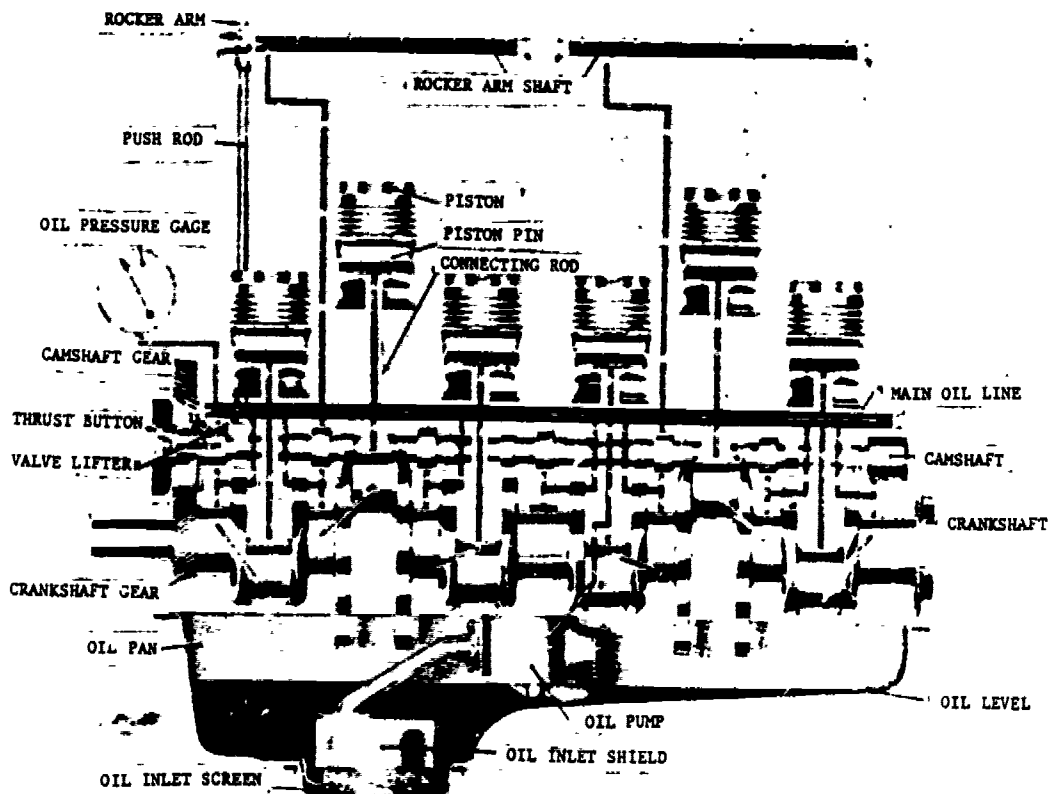

Figure 7. Lubrication system in in-line and V-type engines.

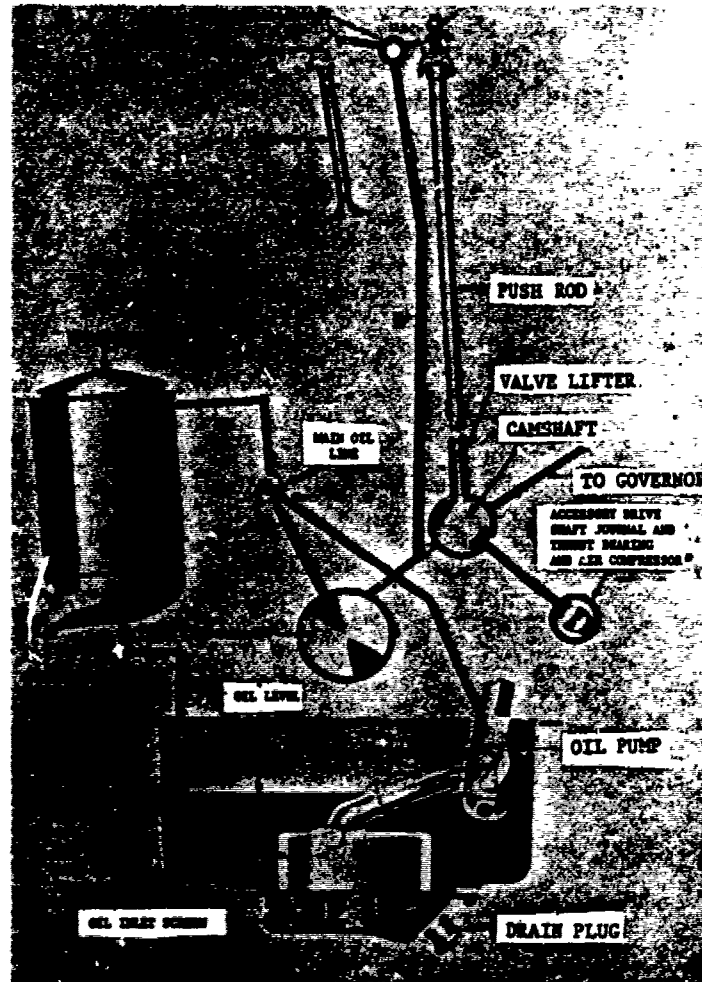

Figure 8. Lubrication system of in-line and V-type engines.

(2) Splash system. The splash system is the simplest method of distributing oil to the bearings, but it is no longer used because the lubricating effect is too uncertain to meet the requirements of modern and varied operating conditions. In the splash system, dippers on the connecting rods enter the oil in the crankcase with each crankshaft revolution, thus splashing the oil. The oil, thrown upward, finds its way to the various moving parts in the engine to provide lubrication. As stated above, this system is too uncertain since a full crankcase means heavy lubrication, while a partly filled crankcase may result in inadequate lubrication. In many engines of today, however, a modified splash system is used that provides a uniform splashing effect, even though there may be variations in the amount of oil in the crankcase. It does this by utilizing a pump that delivers oil to troughs under the dippers on the connecting rods, thus maintaining a constant level of oil into which the dippers enter.

(3) Combination splash and force-feed system. In the combination lubrication system (fig 9) oil is delivered to some moving parts by means of splash and to other parts through oil passages from an oil pump in the crankcase. The oil pump delivers oil under pressure directly to the main bearings through oil passages in the cylinder block. This oil keeps the main bearings supplied with a constant flow of oil which circulates through the main bearings and drips back into the crankcase. Oil is also supplied under pressure to the camshaft bearings. In overhead valve engines, the valve mechanisms are lubricated by oil supplied by the oil pump. The oil is pumped through passages in the cylinder block and through tubes to the hollow rocker-arm shaft, from where it drains out to lubricate the valve mechanisms. The connecting rods, as well as the pistons, piston pin, and cylinder walls, are lubricated by splash from the effect of the dippers splashing into the oil troughs under them. The troughs are kept filled by the oil pump that delivers oil to them through oil nozzles. In some engines, the oil nozzles deliver an increasingly heavy stream with higher engine speeds (because of higher oil pump speed). At higher speeds, the oil stream is powerful enough to directly strike the oil dipper as it moves down toward the oil trough. This action causes a much heavier splash, so that adequate lubrication of the piston and connecting rod bearings is provided at higher speeds.

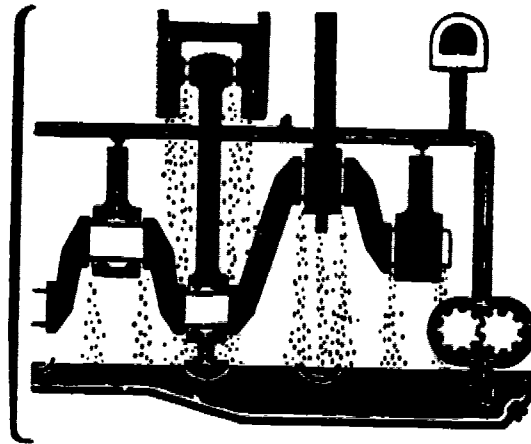

Figure 9. Combination splash and force-feed lubrication system.

(4) Force-feed system. In the force-feed lubrication system (fig 10) a somewhat more complete pressurization of lubrication is achieved. Oil is forced by the oil pump from the crankcase to the main bearings and camshaft bearings (as in the system described above) and to the valve mechanisms in overhead valve engines. Also, oil is forced to the connecting rod bearings through oil passages (or leads) drilled in the crankshaft. The oil enters these passages from openings in the main bearings and main journals. In some engines, these openings are simply holes that index once for every crankshaft revolution. This is sufficient to fill the oil passages in the crankshaft and feed oil to the connecting rod bearings. In other engines, there are annular grooves in the bearings through which oil can feed constantly into the hole in the crankshaft.

(5) Full force-feed system. In the full force-feed lubrication system (fig 11) all the bearings mentioned above are lubricated by oil under pressure. This includes main bearings, camshaft bearings, connecting rod bearings, and valve mechanisms in overhead valve engines. In addition, the full force-feed lubrication system provides lubrication under pressure to the pistons and piston pins. This is accomplished by holes drilled the length of the connecting rod--from the connecting rod bearing to the piston pin bearing. Thus, oil under pressure enters the crankshaft oil passages from where

it passes to the connecting rod bearing. This oil not only feeds out on the piston pin bearing to provide lubrication for it, but it also helps to lubricate the piston and cylinder walls.

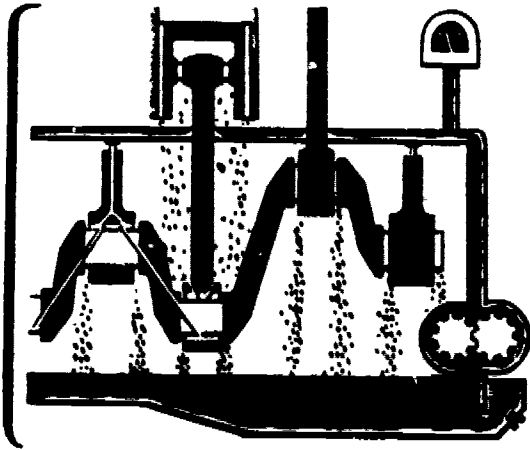

Figure 10. Force-feed lubrication system.

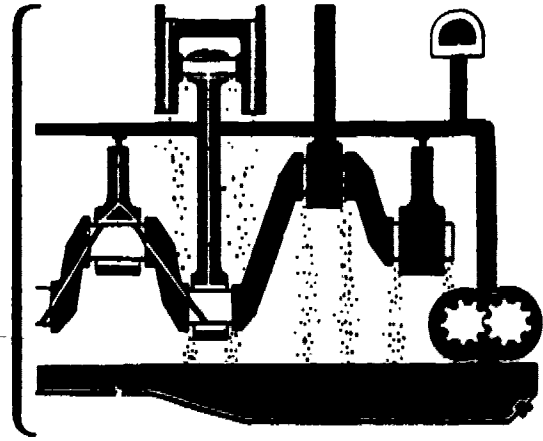

Figure 11. Full force-feed lubrication system.

b. Components.

(1) Oil pumps.

(a) General. The gear pump, the vane pump, the plunger, and the rotor pump are four general types of pumps in common use on automotive material. The oil pump of an engine generally is located in the lower part of the crankcase where it is constantly submerged in oil and primed, ready to start pumping on the first turn of the engine. When used on a dry sump engine to transfer oil from the sump to the oil reservoir, the pumps are required to maintain only sufficient pressure to overcome the friction in the pipe conducting the oil back to the reservoir. When used for pressure lubrication, pumps are usually of such capacity that they will maintain oil pressure of from 15 to 80 pounds per square inch on the bearings and circulate the entire crankcase capacity from 5 to 10 times per minute under normal operating conditions. Pumps are built either with a bypass or pressure relief valve (fig 12 and 13), or one is provided in the oil line. This construction not only prevents excessive pressures in the lubrication system, but also allows the pump to be built with sufficient over-capacity to maintain proper oil pressure even though the bearings or the pump may become considerably worn.

(b) Gear pump. The gear pump, which is most frequently used for engine lubrication, consists of two meshed gears housed in the pump body, one gear driving the other. As the gears revolve and a tooth moves out of a space on the inlet side of the pump, oil enters this space and is carried around to the outlet side of the pump. Here a tooth again enters the tooth space, displacing the oil and forcing it out of the pump outlet. The capacity of such a pump is determined by the size of the gears, the fit of the gears in the body of the pump, and the speed of rotation of the gears. If the gears do not mesh with each other or fit the body of the pump closely, the oil will leak past the gears back to the inlet side of the pump and the pressure and capacity will be lost. If a gear pump is disassembled completely or drained, it may be necessary to prime the pump before again putting it into operation, particularly if the pump is located above the level of the oil in the reservoir.

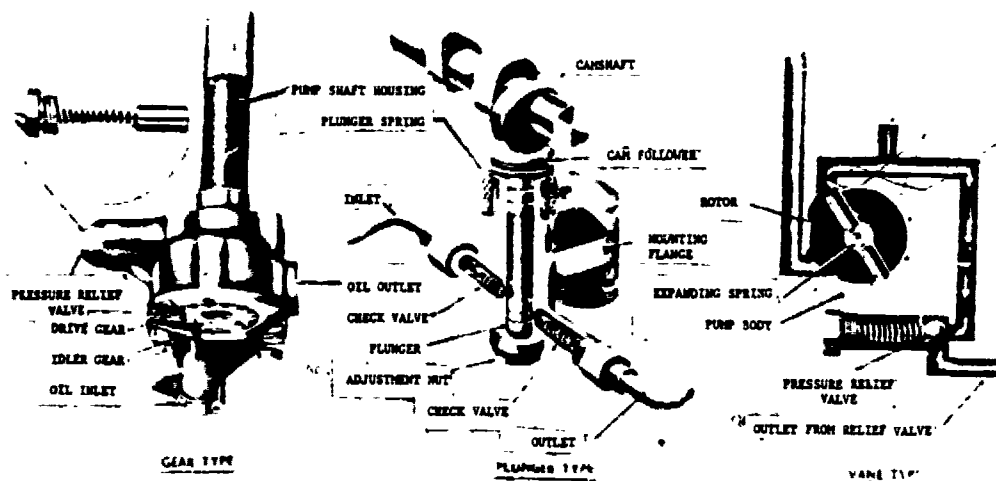

Figure 12. Various types of oil pumps.

(c) Vane pumps. This pump (fig 12) consists of a cylindrical impeller that is set "off center" so that it almost touches one side of the pump housing. The impeller is not eccentric, but the vanes which are set into it have eccentric motion. As the impeller turns, the vanes are forced outward by springs which hold them in contact with the pump body at all times. Oil drawn in after one of the vanes passes the inlet is trapped by the following vane. As the vane is rotated to the opposite side of the pump, the space between the impeller and the pump body becomes smaller. This pushes the vane into the rotor against spring pressure and forces the trapped oil out through the outlet. While one space is emptying, the other is filling.

(d) Plunger pumps. This type (fig 12) is generally a cam-driven, single-cylinder pump and is operated by the camshaft. The plunger or piston is held against the cam by a spring. The plunger is pushed into the cylinder on its pressure stroke by the rise of the cam, and it is returned to the suction stroke by the spring that causes the plunger to follow the drop of the cam. Spring-loaded check valves are used to control the flow of oil. The plunger-type pump is used mostly in splash lubrication systems where it acts as an oil circulator by pumping oil from the oil pan to the oil troughs.

(e) Rotor pump. This pump (fig 14) makes use of an inner rotor with lobes that match similarly shaped depressions in the outer rotor. The inner rotor is off center from the outer rotor. The inner rotor is driven and, as it rotates, it carries the outer rotor around with it. The outer rotor floats freely in the pump body. As the two rotors turn, the openings between them are filled with oil. This oil is then forced out from between the rotors as the inner lobes enter the openings in the outer lobes. The action is much like that in the gear-type pump. As the oil is forced out, it is forced through the oil lines to the various engine parts requiring lubrication.

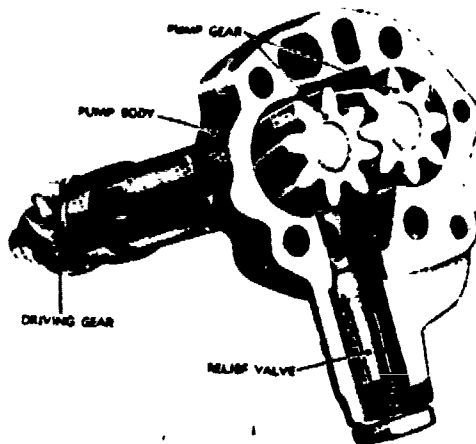

Figure 13. Gear-type oil pump.

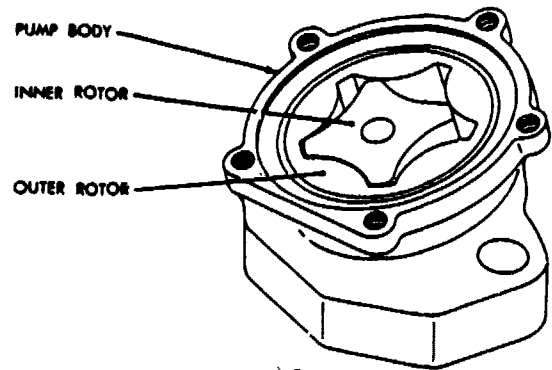

Figure 14. Inner and outer rotors of a rotor pump.

(2) Oil gages. Normally there are two oil gages in an engine: one indicates the pressure of the oil in the system and the other indicates the oil level in the oil pan (in the case of a wet-sump system). In the case of dry-sump engines, the oil level is measured by oil level gages located in the storage tanks. The pressure gage is mounted on the instrument panel. It is calibrated in pounds per square inch, or in some other comparative system, to indicate the pressure in the lubrication system. There are two types of pressure gages--mechanical and electrical. In the mechanical type, the gage on the instrument panel is connected to an oil line tapped into the main oil supply passage leading from the pump. The pressure of the oil in the system acts on a diaphragm within the gage causing a needle to register on a dial. In the electrical type, the oil pressure operates a signaling device on the engine which signals electrically to a dash gage. The dash gage then indicates the oil pressure. Vehicles are fitted with proper gages, and instructions as to the pressure that should be maintained may be found in pertinent technical manuals. The oil level gage is usually of the bayonet type. It consists of a small rod which extends into the oil pan through a small hole in the side of the crankcase. Readings are taken by pulling the gage out, wiping clean, replacing and again removing, and noting the height of the oil on the lower or marked end. Electrically operated warning lights are being used to indicate oil pressure on combat vehicles. These lights indicate abnormal pressures, and on tracked vehicles it is now common practice to use warning lights to indicate excessive oil temperatures.

(3) Oil pressure regulators. In all cases, the output capacity of the oil pump is more than the normal requirement of the engine lubricating system. Therefore, all oil pumps have some means of relieving the excess oil in order to prevent damage from excessive pressure. This is accomplished by the use of the oil pressure regulator valve, which is either built into the pump or located on a main "oil gallery line." Such regulators are sometimes externally accessible for the adjustment required as wear occurs.

(4) Oil cleaner (filter). The oil cleaner or filter (fig 15) is placed in the oil line above the pump. It filters the oil and removes most of the impurities that have been picked up by the oil as it has circulated through the engine and have not been caught by the strainer. The strainer will usually be hinged to the oil pump inlet so that it floats on top of the oil (fig 7 and 8). Thus, all oil taken into the pump comes from the surface. This prevents the pump from drawing oil from the bottom of the oil pan, where

dirt, water, and sludge are likely to collect. The cleaner is mounted outside the engine and is connected so that part or all of the oil passes through it each time the oil is circulated through the engine. Some filters, called full-flow filters, are designed to handle the full output of the oil pump, and all of the oil passes through them before being distributed to the engine parts. Other types divert only a small quantity of the oil each time it is circulated and, after filtering it, return it directly to the oil pan. An air-maze, dish-type filter is frequently used in air-cooled engines. This filter consists of a series of disks made of fine mesh copper screens. Oil can pass through the screens of the disks and exit through small holes drilled on the inner periphery, then through the center filter element tube to the engine. The air-maze filter is usually used as a full-flow filter and is provided with a safety bypass valve. It is of the permanent type and can be cleaned and reused indefinitely.

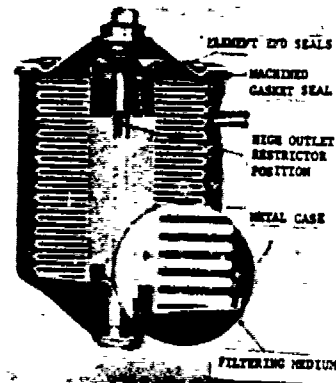

Figure 15. Oil filter.

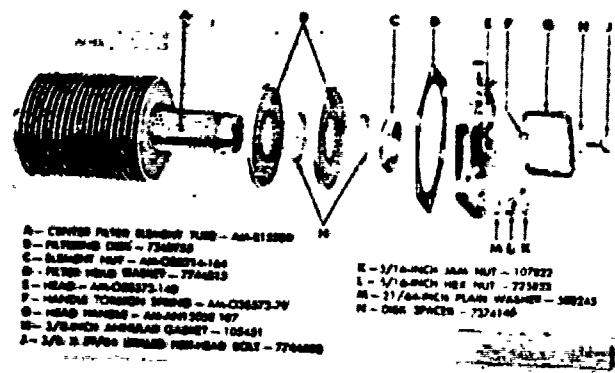

Figure 16. Oil filter--exploded view.

(5) Crankcase ventilators.

(a) General. Gasoline vapor and steam are harmful if they are allowed to remain in the oil. Steam will condense and mix with oil to form sludge; gasoline vapor will condense and dilute the oil. There are two methods of removing these vapors from the crankcase. The first or nonpositive method consists of a breather tube that depends on the flow of air past its open end to remove the vapors. The second or positive method utilizes engine intake manifold pressure to circulate air through the engine.

(b) Breather tube. In the breather tube method (fig 17), one end of the breather tube opens into the crankcase above the oil level; the other end extends down under the vehicle where there is a sufficient air-stream to create a low pressure at the open end of the tube. The pressure differential between the crankcase and the open end of the tube is sufficient to force any vapors out of the crankcase. Some breather tubes are placed so that air from the cooling fan will flow through the tube and increases the pressure differential. There is an opening in the valve cover so that air can enter to replace that forced out of the breather tube.

94

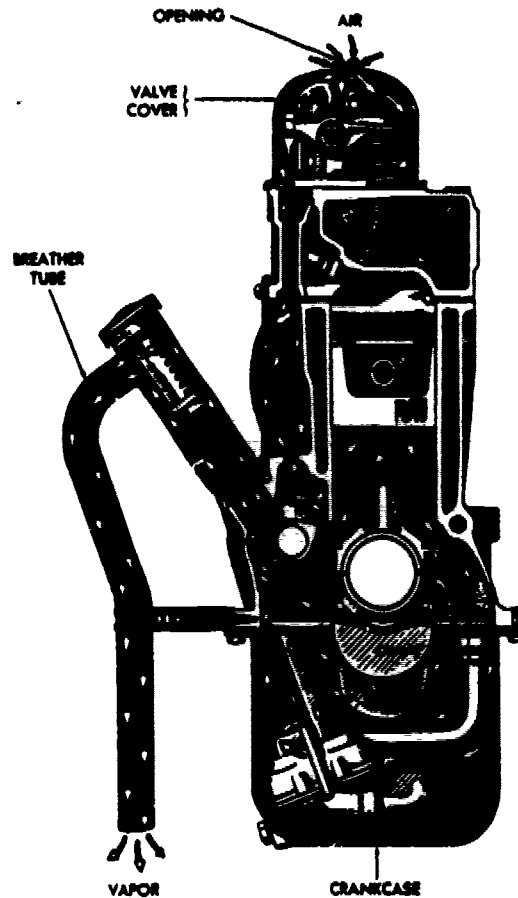

Figure 17. Crankcase breather tube.

(c) Positive method. In the positive method (fig 18), air is drawn through the engine by the intake manifold vacuum; that is, the intake manifold vacuum draws air through the crankcase so that vapors are swept out of the crankcase. The air may follow either of two paths. In one path, air is drawn directly into the crankcase through a filter or crankcase breather similar to a carburetor air cleaner. After circulating through the crankcase and picking up vapors, the air is forced upward and out of the engine through an opening in the valve cover. It is then drawn through a tube connected to the intake manifold. In the second path, air enters through a filter in the crankcase breather, which is mounted on top of the valve cover. This breather also serves as a filler point for adding oil to the engine. In operation, air is taken through the shutoff valve, which is open when the ventilating system is operating, through the filter, and into the valve compartment. From there it passes down into the crankcase and is withdrawn from the crankcase through a tube connected between the crankcase and the intake manifold. This second arrangement is in general use in waterproofed vehicles. The breather shutoff valve is operated by a control knob in the driver's compartment and is to be used only when the vehicle is fording.

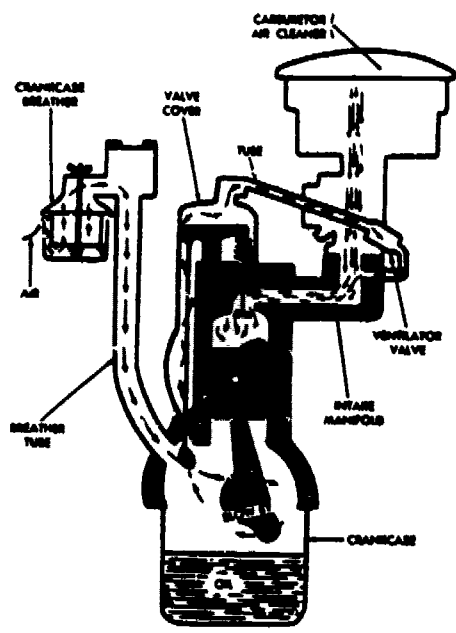

Figure 18. Positive crankcase ventilation.

(6) Oil temperature regulator. The oil temperature regulator is used to prevent the oil temperature from rising too high in hot weather and to assist in raising the temperature during cold starts in winter weather. The regulator makes use of the liquid in the cooling system, and it provides a more positive means of controlling oil temperature than does cooling by the radiation of heat from the oil pan walls. The regulator unit is made up of a core and a housing. The core through which the oil circulates is of cellular or bellows construction, and it is built to expose as much of the oil as possible to the coolant that circulates through the housing. The regulator is attached to the engine so that the oil will flow through the regulator after passing through the pump. The oil leaves the regulator either cooled or heated, depending on the temperature of the liquid in the cooling system, and enters the oil passages to the engine parts. The types of oil coolers used with combat vehicles consist of a radiator through which air is circulated by movement of the vehicle or by the cooling fan. Oil from the engine is passed through this radiator, back to the engine, and to the oil supply tank. This radiator acts only to cool the oil; it does not function as a regulator in which the temperatures may be increased during cold weather operations.

5. MILITARY LUBRICANTS AND LUBRICATION.

a. Grades of lubricants used. Crankcase oils most commonly used are OE50, OE30, OE10, and OES. The numerical designations are equivalent to SAE ratings. The OES grade is a special engine oil to be used in extremely cold atmospheric conditions. In normal operating atmospheric temperatures--above 32° F--the air-cooled engines require OE50, while the liquid-cooled engines will use OE30. In the middle range of atmospheric temperatures--+40° F to -10° F--the requirement is for OE10 for both air-cooled and liquid-cooled engines. In extreme cold--0° F to -65° F--all engines require an OES oil. For specific instructions always consult the lubrication order pertinent to a vehicle.

b. Intervals for oil change. Normally, the interval for oil changes is every 1,000 miles or semiannually for air-cooled engines. Liquid-cooled engines require oil changes every 12,000 miles or annually. These intervals are for normal operation. The time is reduced under extremely adverse conditions, such as dusty air, high or low temperatures, prolonged periods of high-speed operation, immersion in water, or exposure to moisture. Any of these conditions may cause contamination and quickly destroy the protective quality of lubricants. Intervals may be extended during inactive periods commensurate with adequate preservation. In all cases, oil levels must be kept at a normal level by checking the oil each day of operation. When OES oil or diluted oils are used for extreme cold weather operations, the level must be checked more frequently as oil consumption is likely to be high. Even though the oil level is correct, adequate lubrication is not assured unless the oil is circulating. Observe the oil pressure gage and do not operate an engine unless the correct pressure is noted.

c. Change of oil filters. In liquid-cooled military engines, the filter is changed with each oil change. The inside of the filter case should always be cleaned prior to installation of the new filter. However, the filter drain plug should be removed and the sediment drained at 1,000-mile intervals. Military air-cooled engine oil filters must be removed and cleaned at 750-mile intervals or quarterly. They are of the permanent type and are replaced only when damaged or otherwise unserviceable. In all instances consult the appropriate technical manual and lubrication order for lubrication system servicing procedures for a specific vehicle.

. Lubrication orders (LO's).

(1) Lubrication orders are illustrated, waterproofed, numbered, and dated cards or decalcomania labels that prescribe approved organizational maintenance lubrication instructions for mechanical equipment issued by the support services. They are to be carried with or attached to the equipment to which they pertain. The instructions they set forth are mandatory. Unit commanders are responsible for obtaining, installing, and complying with all current lubrication orders that apply to the equipment within their command.

(2) Lubrication orders bear the basic number and subnumber of the technical manual (TM) or technical bulletin (TB) that best covers the preventive maintenance of the equipment. When a TM or TB does not exist, is not complete, or when the existing technical manual was prepared by another technical service, the LO will bear a basic number identifying the type of equipment; this is followed by the letter U and a serial number. Lubrication orders are indexed in DA Pam 310-4. Consult this pamphlet to determine the current lubrication orders.

6. EFFECTS OF WEATHER ON LUBRICATING SYSTEMS.

a. General. Military vehicles may be used in almost any area on the face of the globe. They are designed and manufactured for certain average conditions; special maintenance operations are used to cover extreme conditions. Aside from vehicle casualties in combat and wear, maintenance problems arise chiefly from the type of service (driver control, engine speeds, and engine loads) and the operating conditions (climate, atmospheric contamination, and terrain).

b. Preventive maintenance. Preventive maintenance (PM) procedures are prescribed in order to secure continuous efficient engine operations and to prolong periods between rebuilds. In some areas, conditions such as relatively high or low temperatures, high humidity, dusty air, steep grades, etc, cause engine malfunctions and harmful crankcase contamination. The

maintenance of proper engine adjustments; the regular cleaning and servicing of air cleaners, ventilation systems, cooling systems, oil filters, etc; and the following of prescribed engine oil draining procedures are important elements in dependable engine service.

c. Importance of lubrication. Lubrication is the most important factor in engine operation. Operating factors that cause lubricant deterioration and contamination may be divided into five general classifications: high engine temperatures, low engine temperatures, contamination by dust from the atmosphere, contamination by water from cooling system leaks or from condensation, and contamination byproducts of improper fuel combustion (soots and unburned fuel). These factors may develop from either the severity of the type of service (driver control, speed, and loads) or the inadequacy of preventive maintenance measures taken. Adequate preventive measures will compensate for the harmful effects of adverse conditions (weather and terrain).

d. Atmospheric temperatures. Recorded world atmospheric temperatures vary from a low of -90° F to a high of +136° F. Within the limits of the continental United States, there is a sufficiently wide variation in rainfall, relative humidity, terrain, dust, and freezing conditions to afford fairly direct comparisons with almost any area on the globe, with the exception of the extremely cold arctic region. Experience obtained from military vehicle operation in the various areas throughout the continental United States can be related to almost any set of operating conditions which may be encountered in any area throughout the world. The influence of climate on engine operation may be considered under the following temperature ranges.

(1) Temperatures below 0° F--severe cold, requiring special equipment for engine starting and operation.

(2) Temperatures between 0° F and +32° F--winterization kits are not prescribed; however, certain precautionary and engine-warming steps are essential.

(3) Temperatures between +32° F and +50° F--moderate cold, requiring precautionary and engine-warming steps for vehicles in intermittent service.

(4) Temperatures between +50° F and +85° F--ideal operating temperatures.

(5) Temperatures above +85° F--high temperature problems.

e. Engine operation at high atmospheric temperatures.

(1) Cooling system maintenance. As two-thirds or more of the available energy in a fuel consumed in an internal combustion engine is unused and must be dissipated as heat, crankcase oil temperatures are dependent upon the proper function of the engine and the engine cooling system. Hence, wherever temperatures are high or loads are heavy, oil temperatures may become excessive if the engine functions poorly or improperly. For this reason, it is especially important that emphasis be placed on the maintenance of clean, deposit-free, water jackets and radiator cores, as well as on the efficient operation of the fan, water pump, thermostat, oil cooler, and manifold heat control.

(2) Engine adjustments. An improper adjustment of ignition or valve timing or improper carburetor fuel mixtures will cause excessive local temperatures in the upper cylinder area of the engine. The results of excessive temperatures in these areas frequently are piston ring sticking, varnish deposits on piston skirts and valve stems, piston scuffing, burned valves, breakdown of the lubricating oil to form deposits of carbon on the underside of the piston head, and general engine sludging.

(3) Engine loads and speeds. Excessive speeds or engine lugging (operation in too high a gear) will rapidly increase oil and engine temperatures. As higher engine speeds also place increased loads on bearings and other working surfaces, greater demands are placed upon the lubricant for adequate lubrication. The higher temperatures obtained will result in reduced load-carrying ability of the lubricant. Hence, excessive speed or engine lugging are particularly dangerous and should be avoided when atmospheric temperatures are high or loads are heavy.

(4) Lubricant deterioration. The most immediate result of heat is the temporary thinning of the oil. Continued exposure to high temperatures, however, will result in the evaporation of the more volatile fractions of the oil, thus leaving the oil more viscous in body. Also, in the presence of air and particularly where the oil is in contact with metals, oxidation of the oil occurs. This results in the thickening of the lubricant and in the formation of sludges, lacquers, varnishes, and other objectionable oil oxidation products. Oils meeting Specification USA 2-104 have been refined from stable base stocks and processed to retard oxidation and to prevent the deposition of decomposition products, fuel soots, and sludge in the oil passages, ring grooves, and engine parts. However, all petroleum oils will break down if the temperatures are extreme; consequently, it is important that engine adjustment and temperature control equipment be maintained properly and that proper oil drain procedures at specified intervals be followed. As the film of the lubricant becomes thinner, any abrasive material that may have entered the engine from the atmosphere, or from the engine itself, will be more damaging due to the lack of sufficiently protective layers of oil.

f. Cold weather problems.

(1) General. When engine crankcase temperatures are low (below 140° F), engine efficiency is very poor and wear and engine deterioration occur at a faster rate. Atmospheric temperatures below 0° F make these problems acute and require special provisions in the form of winterization kits for the starting and operation of vehicles. Where operation of a vehicle is intermittent (frequent starts and stops), the engine temperature will not be high enough when atmospheric temperatures are below +50° F, unless steps are taken to provide an adequate engine temperature.

(2) Wear accelerated by cold sluggish lubrication. A distinctive characteristic of all petroleum lubricating oils is that they become thick (heavier in viscosity) as their temperature is reduced; this means that oil will be pumped more slowly through oil passages and will penetrate less readily through small clearances. Sufficiently low temperatures are experienced in many parts of the world to cause oil to congeal. A cold sluggish lubricant places a heavy drag on the movement of engine working parts and this places a heavy load on the battery, the efficiency of which is very poor at low temperatures. The sluggish flow of the lubricant to bearings and cylinder regions means that lubrication must come from whatever lubricant has remained clinging to these parts until a further supply is furnished by the oil pumped through the lubricating system. Consequently, lubricant films are apt to be inadequate and actual metal-to-metal scuffing may occur during the starting of a cold engine.

(3) Water emulsion sludges. For every gallon of gasoline burned in an engine, more than a gallon of water is formed which, at normal operating temperatures, will pass off through the exhaust and the engine ventilation system in the form of vapor. However, when cylinder walls are cold, this water vapor will condense and run down past the pistons and rings to contaminate the crankcase lubricant and to form a black sludge. Crankcase oil pans may become loaded and oil screens plugged. Valves, valve chambers, and timing gear cases may become coated to the extent that the lubricant cannot reach the working parts. Water will absorb acid gases formed by combustion and cause corrosion and rust.

(4) Engine oil filters. Filters are connected in the oil system with a bypass. This construction continuously passes to the filter only a small percentage of the oil being pumped. Oil filters become more loaded or clogged from cold weather type sludges than from abrasives. For this reason, filters do not become loaded as quickly during warm, dusty operations as they do in cold, humid areas when cold weather type sludges are more apt to occur. As the resistance to oil flow through the filter elements is increased by the oil becoming thicker at low temperatures, very little filtration occurs when engine oil temperatures are low. Consequently, the oil filter cannot be expected to help in keeping the oil clean unless engine operating temperatures permit appreciable oil passage through the filter elements.

(5) Combustion problems. Combustion of fuel in an internal combustion engine is similar to the burning of kerosene in a lamp or stove. If the mixture of fuel and air is too rich (too large a portion of fuel to air), some of the fuel will be burned only partially to form soot such as may be formed on a lamp chimney or on the bottom of a pan. If the fuel is not vaporized properly, some of it will not burn at all but will drip off the burner. Unburned fuel is the source of fuel dilution of oil in the crankcase of an engine. Where engine temperatures are inadequate, it is difficult to get proper atomization of the fuel and, consequently, choking the carburetor for a richer mixture is necessary. This results in abnormal amounts of soot being formed and increases carbon deposits on piston heads and permits blowby of soot into the ring area and down into the crankcase lubricant. Fuel striking the cold cylinder walls condenses and washes down past the rings, carrying the cylinder wall lubricant with it, contaminating and thinning the crankcase lubricant.

(6) Prevention of sludge. In order to reduce cold weather sludge and resulting engine wear in automotive engines, it is absolutely essential that the cooling system temperature be raised to a minimum of +140° F as soon as possible after starting and, so far as practicable, be maintained at +160° F to +180° F at all times while the engine is operating. The action prescribed below is applicable for all atmospheric operating temperatures below +32° F, as well as for more moderate temperatures if difficulty is experienced in raising cooling systems to +140° F and maintaining such temperatures at +160° F while the engine is operating.

(a) Inspect and test the cooling system thermostats to insure that the valves open and close at specified temperatures. These can be checked by removing and immersing elements in water heated to the specified temperatures.

(b) Cover hood louvers with heavy cardboard or other suitable material. This is done best from the inside of the hood.

(c) Cover radiator cores wholly or partially in accordance with atmospheric temperatures. The amount of the radiator core that must be covered in order to obtain the temperatures referred to in paragraph (6) above will vary with different vehicles and will have to be determined by trial. For temperatures of +32° F to 0° F, the lower half of the core may



need to be covered unless operation at high speed or under severe load is expected. For operations between +32° F and +50° F where operation is intermittent (frequent stops and starts, excessive idling, or infrequency of use), covering the lower quarter of the core may be necessary. The radiator core covering applied for intermittent operation protection should be removed whenever high-speed or heavy-load operation is anticipated.

(d) Check and tighten cylinder head studs with a torque indicating wrench, as prescribed in applicable technical manuals, to prevent liquid from leaking past the gaskets.

(e) Many engines cannot be warmed up by idling. Therefore, the practice of running engines for prolonged periods at idling speeds to warm them is of little value. Start engines with the clutch disengaged and maintain engine speed at a fast idle until the engine is firing evenly on all cylinders and running smoothly. As soon as the engine will accept a load without faltering and the oil pressure has reached its normal operating range, the vehicle will be operated by the use of low gear ratios and low speeds. At no time (except in emergency conditions) will the engine be operated at high speeds or under heavy load until the dash thermometer indicates that the engine has reached the normal operating temperature.

(f) The practice of running engines solely to charge batteries is prohibited.

(g) Each crankcase oil change will be scheduled so as to be performed immediately after engine operation and while the engine is still hot. Care will be taken to drain the oil completely.

(h) Oil filter cases will be drained at reduced intervals when equipped with drain cocks (or plugs) to remove sediment. It may be necessary to drain filters daily under unusually severe conditions.

(i) When it is known that an engine is badly sludged, the crankcase pan will be dropped and sludge removed from the pan, valve mechanism, and exposed parts. At the same time, clean the oil pump screen thoroughly.

(j) When an engine has been operated for an extended period under conditions where cold engine sludge accumulations are being experienced and a change to high speeds or heavy loads is anticipated, it is advisable to flush with an engine conditioning oil to reduce sludge accumulation before the vehicle is placed in severe service where warm engine temperatures are expected. The following procedures will be used in flushing:

1. Fill the crankcase with an engine conditioning oil to half capacity for engines with pressure circulation systems or to the full mark for engines with splash systems.

2. Run the engine at fast idle for one-half hour with the radiator blanketed in order to assist in warming the oil.

3. Maintain the cooling system between +180° F and +200° F, watching the water temperature and oil pressure gages continuously.

4. Drain the crankcase, replace filter elements, and refill with proper oil.

Note. - Such flushing will not prevent further sludge accumulation, but will reduce the hazard of screen clogging and lubrication failure from sludge that may be dislodged and put in circulation by warm oil.

8. Accelerated wear from dust.

101

(1) Dust. Wear from dust will depend upon the character of the dust particles as well as the quantity of dust in the air. Military vehicle operation includes a great deal of travel over open fields in dusty areas, which makes the problem of control of wear from abrasives a very important one. Abrasives from dusty air enter the engine through several channels: the air intake system, engine breathers, through contamination of the lubricant during storage, or in the process of adding oil to the crankcase from contaminated filling receptacles.

(2) Effect of thinned lubricant. Wear from abrasive particles is accelerated whenever the lubricant film becomes thin, either through the thinning effect of high engine temperatures or through fuel dilution.

(3) Air cleaner maintenance. If air cleaner elements become dirty, or the oil level in the element becomes low, dust particles will be sucked directly into the combustion chamber. Large accumulations of dirt in the air cleaner elements will lower filtering efficiency, and will also reduce the air supply for combustion with a resulting loss of engine power. Leaky joints in connections or deterioration of the flexible airhose connections between the air cleaner and the carburetor will provide a direct channel for abrasives into the combustion chamber. Dirt accumulation on the piston heads will accelerate carbon deposits and reduce heat transfer. Products of abrasion, metal particles, and pulverized dirt will be washed down into the crankcase to further circulate and result in abrasion of bearings and journals and the clogging of oil passages. Dust entering the crankcase through the air induction or breather system causes initial damage by abrasion of the cylinder walls, pistons, and piston rings. That which is absorbed by the crankcase oil is circulated to the other bearing surfaces.

(4) Dirty oil-handling receptacle. Loose or unserviced breather caps, loose or missing oil filler pipe caps or bayonet-gage sticks, or the use of dirty filling receptacles are responsible for a high percentage of engine damage in dusty or sandy areas. Sand or dirt entering the crankcase through these channels will be composed of both large and small particles. The large particles will be removed by the oil pump strainers and probably do no appreciable damage. The fine particles, however, circulate through the lubrication system and are a serious threat to bearings and other working surfaces. While the large sand particles found in the crankcase oil pan do not themselves directly indicate engine abrasion, they are evidence that fine particles probably have been circulating and causing serious wear. Do not expect the oil filters to offer complete protection from abrasives for the engine, as most filters operate on a bypass system and only part of the oil passes through the filter on each circulation, the balance going directly through the engine lubricating system to bearings, cylinder walls, etc.

EXERCISE

41. Which type of friction consumes the greatest amount of power and produces the greatest amount of heat?
- Rolling
 - Fluid
 - Sliding
42. What effect does the oil film and wedge theory pertain to?
- The separation of oil between two sliding surfaces
 - The degree to which an oil film splits up into molecules
 - The action of an oil film between a rotating shaft and its bearing

OS 607, 4-P23

- 102
43. The THREE fundamental factors which influence the selection of the proper grade of lubricant for any normal bearing are the rubbing speed, the clearance between bearing surfaces, and the
- load on the shaft.
 - temperatures to be encountered.
 - size of the rotating shaft.
44. What is the primary function of engine lubrication?
- To dissipate heat
 - To reduce friction
 - To clean the engine
45. What is subjected to the MOST severe friction in an internal combustion engine?
- The piston rings
 - The valve stems
 - The camshaft lobes
46. To which type engine is the "dry sump" system most common?
- In-line
 - V-type
 - Radial
47. Which engine lubricating system is too uncertain to meet the requirements of present-day engines?
- Force-feed
 - Splash
 - Full force-feed
48. Which lubrication system pumps oil through a passage drilled in the connecting rods?
- Full force-feed
 - Splash
 - Force-feed
49. Which type oil pump consists of a cylindrical impeller set off center in a pump housing?
- Rotor
 - Gear
 - Vane
50. What removes steam and vapor from the crankcase of an engine equipped with the breather tube ventilator?
- Low pressure of the intake manifold
 - Vacuum created by the airstream under the vehicle
 - High pressure of the exhaust manifold
51. What type publication contains an index of lubrication orders?
- Army regulation
 - DA pamphlet
 - Technical bulletin

- 103
52. Excessive speed or engine lugging is particularly dangerous under which atmospheric condition?
- a. High humidity
 - b. Low humidity
 - c. High temperature
53. Under what condition does engine wear from abrasive particles accelerate?
- a. If the engine is operating at low speed
 - b. If a heavy grade oil is used
 - c. If the engine lubricant is diluted
54. Which climatic temperature range is considered ideal for engine operation?
- a. +32° F to 50° F
 - b. +50° F to +85° F
 - c. +85° F to 110° F
55. Under what climatic conditions does the engine oil filter sludge over the quickest?
- a. Cold and humid
 - b. Hot and humid
 - c. Cold and dusty

OS 607, 4-P25

CORRESPONDENCE COURSE
of the
US ARMY ORDNANCE
CENTER AND SCHOOL



104

LESSON ASSIGNMENT SHEET

Ordnance Subcourse No 607. Engine Principles
Lesson 5 Engine Cooling Systems
Credit Hours Three
Lesson Objective After studying this lesson you will be able to discuss the construction and operation of liquid- and air-cooled engines, coolants used, and a comparison of the two types of cooling.
Text Attached Memorandum
Materials Required Answer sheet and exercise response list
Suggestions. None

STUDY GUIDE AND ATTACHED MEMORANDUM

1. INTRODUCTION.

a. The engine cooling system is called upon to eliminate approximately one-third of the heat generated during the combustion process. Although heat dissipated by the cooling system represents wasted energy that is not converted into useful work, the temperature limitations of cylinder wall lubricants and the tendency of fuels to detonate at elevated temperatures make heat dissipation mandatory. On the other hand, it is desirable to operate the engine at temperatures close to the limits imposed by fuel and lubricants, because a reduction in heat rejected by the engine is reflected in an increase in thermal efficiency.

b. Usually, a cooling system functions by circulating a liquid through jackets surrounding the cylinders, head, and valves. The circulating liquid absorbs heat and transfers it to a heat exchange unit known as a radiator, from where it is in turn transferred to the ambient air. This type of cooling system is known as liquid cooling. Because liquid cooling is the most common type of cooling employed in the automotive field, most of this lesson will be centered around it.

c. Sometimes a cooling system has no circulating liquid, but depends upon the direct transfer of heat through cylinder walls to the atmosphere. This system is known as air cooling.

OS 607, 5-P1
December 1975

d. Diesel and gasoline engine cooling systems are similar mechanically; however, as the diesel runs cooler, it is not necessary that the capacity of its cooling system be as large as that of a gasoline engine. Diesel engines usually have the same size radiators as gasoline engines, but the speed and size of the fans are reduced.

2. COOLANTS.

a. Water is the most widely used coolant for liquid-cooled engines as it is usually available, costs practically nothing, and its boiling point falls within the range of efficient operating temperatures. Water used for coolant should be clear and soft. The main objection to the use of water is that it has a high freezing point and cannot be used alone at temperatures below $+32^{\circ}$ F. Ethylene glycol is used in most engines where the cooling system is sealed. Its advantages are that it does not evaporate in use, has a higher boiling point than water, and does not require renewal unless lost through leakage.

b. When a liquid-cooled engine is operated where the atmospheric temperatures fall below $+32^{\circ}$ F, an antifreeze solution must be added if water is used as the cooling liquid. The four solutions in common use are methyl alcohol, ethyl alcohol, glycerin, and ethylene glycol. The first two, prepared commercially as antifreeze, are the cheapest and provide adequate protection when used in sufficient quantities. The main objection to them is that they boil and evaporate if the normal operating temperature is exceeded. Glycerin offers the same degree of protection as alcohol and does not evaporate in use because it has a high boiling point. Ethylene glycol (antifreeze compound) has an extremely high boiling point ($+330^{\circ}$ F), does not evaporate during use, is noncorrosive, has no odor, and gives complete protection when used in the proper amount. The best protection from freezing is obtained from a solution of 40 percent water and 60 percent ethylene glycol antifreeze compound. This mixture gives protection at temperatures as low as -65° F. A higher concentration of ethylene glycol antifreeze compound will only raise the freezing point of the solution. If a 100 percent ethylene glycol antifreeze compound is used, the freezing point is not much below that of water. Other antifreeze solutions, however, do not show this increase of freezing point with increasing concentration. For instance, methyl alcohol freezes at -144° F while ethyl alcohol freezes at -174° F.

c. The cooling system must be free of rust and scale in order to maintain its efficiency. The use of inhibitors (rust preventives) will reduce or prevent corrosion and the formation of scale. Inhibitors are not cleaners and do not remove rust or scale already formed; they are merely added to the cooling liquid to arrest further rust or corrosion. Most commercial antifreeze solutions contain an inhibitor. If water alone is used as the coolant, an inhibitor should be added.

3. USE OF ANTIFREEZE SOLUTIONS.

a. The practice of keeping antifreeze solutions in engine cooling systems in operating vehicles throughout the warm weather period is recommended. The practice of reclaiming used antifreeze solutions is authorized and is recommended.

b. During use, some antifreeze solutions are subjected to conditions which tend to deplete their corrosion-inhibiting properties. Conditions that may lead to this depletion are high speeds, heavy loading of the engine, rust deposits in the system, etc. It is not possible to predict when any of these conditions will lead to the corrosion of the cooling system in a given engine because of the varying extent of each condition. It is certain, however, that corrosion will eventually take place if the solution is kept in the engine cooling system for longer duration.

4. DRAINING AND REFILLING ANTIFREEZE SOLUTION.

a. At the end of each cold weather season, antifreeze solutions may be drained from engine cooling systems by opening the radiator drain cocks and engine block drains. Vehicles required to be maintained combat ready will not have their cooling systems drained but will be checked for maximum protection. Solution will be added as required.

b. After draining antifreeze solutions, cooling systems should be refilled with fresh clean water and a corrosion inhibitor. Five ounces of inhibitor are required for each 10 quarts of water. The inhibitor should be dissolved in warm water and poured into the radiator while the engine is idling.

c. In preparation for the cold weather season, completely drain the cooling systems (when required) and refill them with fresh antifreeze solution in accordance with the following criteria:

(1) In areas where the lowest temperature that may be encountered is below -55° F, use an arctic grade antifreeze. Do not dilute arctic grade antifreeze with water or inhibitor; it is ready for use as issued.

(2) In areas where the lowest temperature that may be encountered is -55° F or higher, use ethylene glycol antifreeze. Prepare ethylene glycol antifreeze solutions in accordance with instructions in the protection tables printed on the antifreeze containers.

(3) In addition to normal protection, for those vehicles required to be maintained combat ready, a sufficient quantity of ethylene glycol antifreeze will be continuously available to provide for maximum protection to -55° F at the time of movement.

(4) Test the solution in the cooling system with an antifreeze tester to insure that the coolant will not freeze at the selected estimated temperature. The freezing protection of the solution is determined from readings in the tester by referring them to the protection chart.

5. LIQUID COOLING SYSTEM OPERATION. Cooling of the engine parts is accomplished by keeping the coolant circulating (fig 1) and in contact with the metal surfaces to be cooled. The pump draws the coolant from the bottom of the radiator, forces it through the jackets and passages, and ejects it into the upper tank on top of the radiator. The coolant then passes through a set of tubes to the bottom of the radiator, from where it is again circulated through the engine by the action of the pump. A fan draws air over the outside of the tubes in the radiator and cools the liquid as it flows downward. It should be noted that the liquid is pumped through the radiator from the top down. The reason for this direction of flow is that thermosiphon action aids the pump in circulating the coolant. This simply means that as the coolant is heated in the jackets of the engine, it expands, becomes lighter, and flows upward to the top of the radiator. Then, as cooling takes place in the radiator tubes, the coolant contracts, becomes heavier, and sinks to the bottom. This desirable thermosiphon action cannot take place if the level of the coolant is permitted to become low.



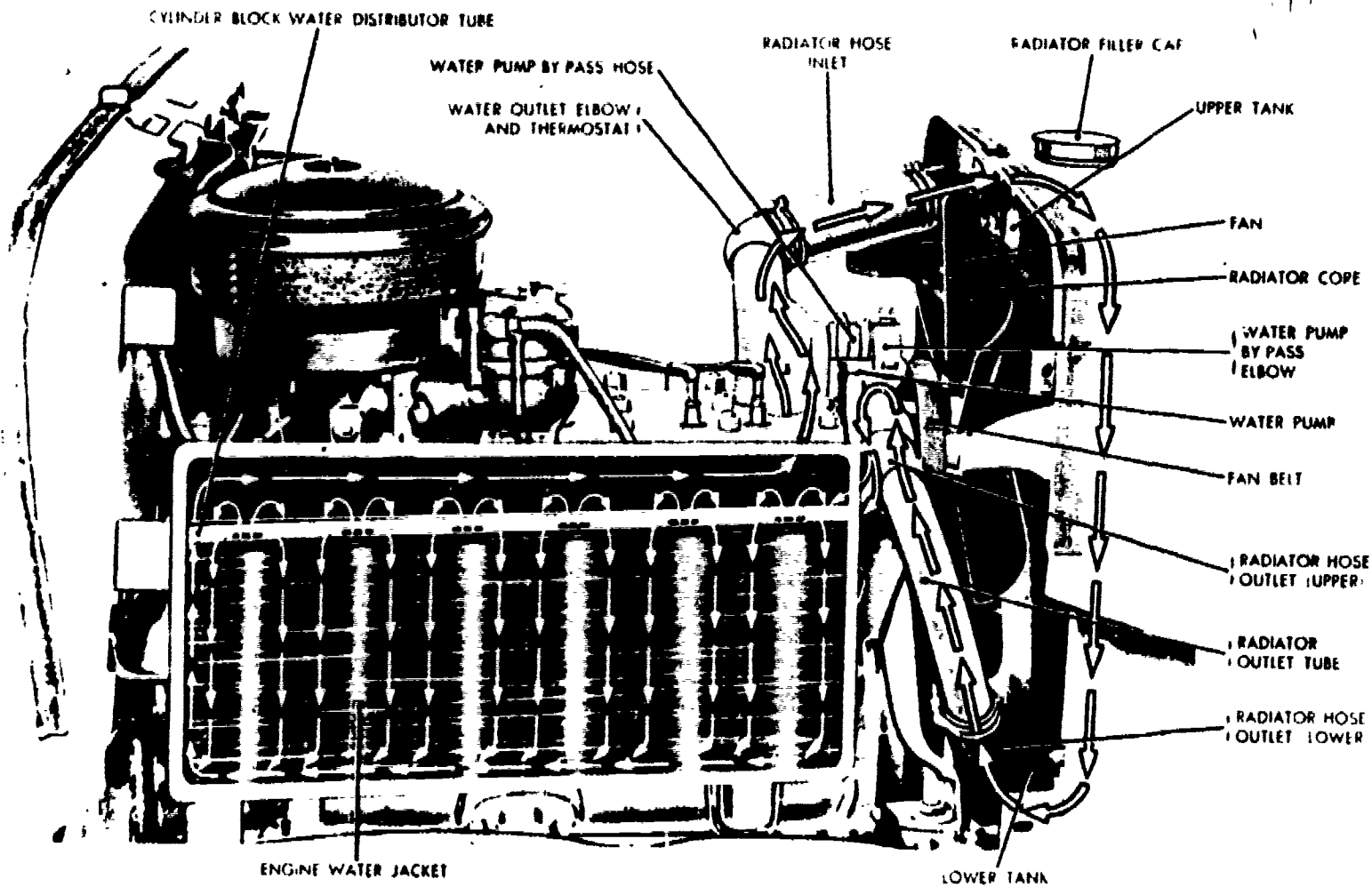

OS 607, 5-P4

Figure 1. Cooling system circulation.

6. COMPONENTS OF LIQUID COOLING SYSTEM FOR SPARK IGNITION ENGINES.

108

a. Engine water jacket.

(1) The water passages in the cylinder block and cylinder head form the engine water jacket (fig 1). In the cylinder block, the water jacket completely surrounds all cylinders along their full length. Within the jacket, narrow water passages are provided between cylinders for coolant circulation; in addition, water passages are provided around the valve seats and other hot parts of the cylinder block.

(2) In the cylinder head, the water jacket covers the combustion chambers at the top of the cylinders and contains water passages around the valve seats when they are located in the head. The coolant flows from the cylinder block up into the cylinder head through passages called water transfer ports. A tight seal at the ports between the cylinder head and block is very important. The watertight seal at the ports, as well as the gastight seal at the combustion chamber openings, is obtained with one large gasket called the cylinder head gasket.

b. Radiator.

(1) Radiators for automotive vehicles using liquid cooling systems consist of two tanks with a core between them to form the radiating element. The upper tank contains an outside pipe called the radiator inlet, and it usually has a coolant baffle inside and above or at the inlet opening. The radiator filler neck is generally attached to the upper part of the upper tank and has an outlet to the overflow pipe. The lower tank also has a pipe opening (radiator outlet).

(2) The upper tank collects incoming coolant and distributes it across the top of the radiator core. The baffle in the tank assists in distributing the coolant to the water tubes and also prevents coolant from being thrown out of the radiator. The overflow pipe provides an opening from the radiator for escape of coolant or steam that otherwise might cause excessive pressure, which would rupture the thin metal walls of the radiator. The lower tank collects coolant flowing from the core and discharges it through the radiator outlet.

(3) Tubular radiator cores (fig 2) consist of a large number of vertical water tubes and many horizontal air fins around the tubes. Water passages in the tubes are narrow and the tubes are made of thin metal. The core divides the coolant into very thin columns or ribbons, thus exposing a large radiating surface to the volume of liquid to be cooled.

(4) Most vehicles, both military and civilian, utilize a pressurized radiator cap. The pressure cap (fig 3) contains two spring-loaded normally closed valves which seal the cooling system. The larger valve is called the pressure valve and the smaller one the vacuum valve. A shoulder in the radiator filler neck provides a seat for the bottom of the cap assembly and a gasket on this seat prevents leakage between the cap and the filler neck. By closing off the overflow pipe opening, the pressure cap prevents overflow loss of coolant during normal operation. It also allows a certain amount of pressure to develop within the system, thereby raising the boiling point of the coolant and permitting the engine to operate at higher temperatures without coolant overflow from boiling.

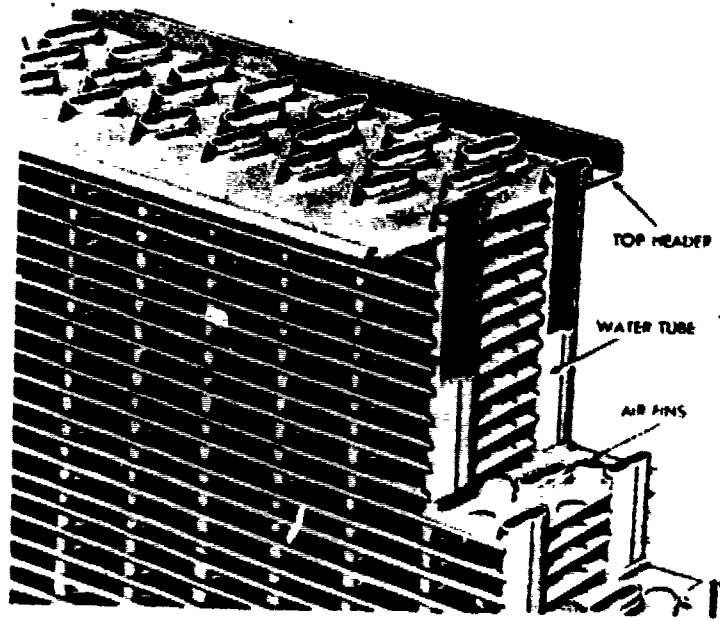

Figure 2. Tubular radiator core construction.

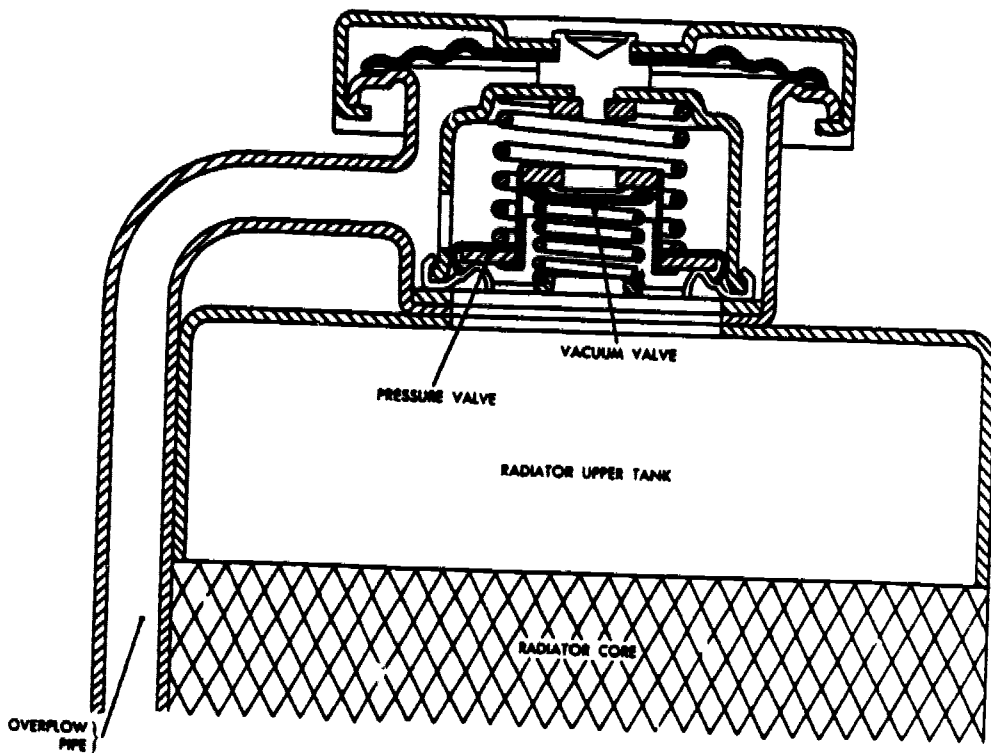

Figure 3. Pressure radiator cap.

c. Water pump.

(1) All modern cooling systems have water pumps to circulate the coolant. The pump (fig 4), which is usually located on the front or side of the engine block, receives coolant from the lower tank and forces it through the water jacket into the upper tank. The pump is a centrifugal type and has an impeller with blades which force the coolant outward as the impeller rotates. The pump and fan usually are driven from a common V-belt that is, in turn, driven by a pulley at the front end of the crankshaft.

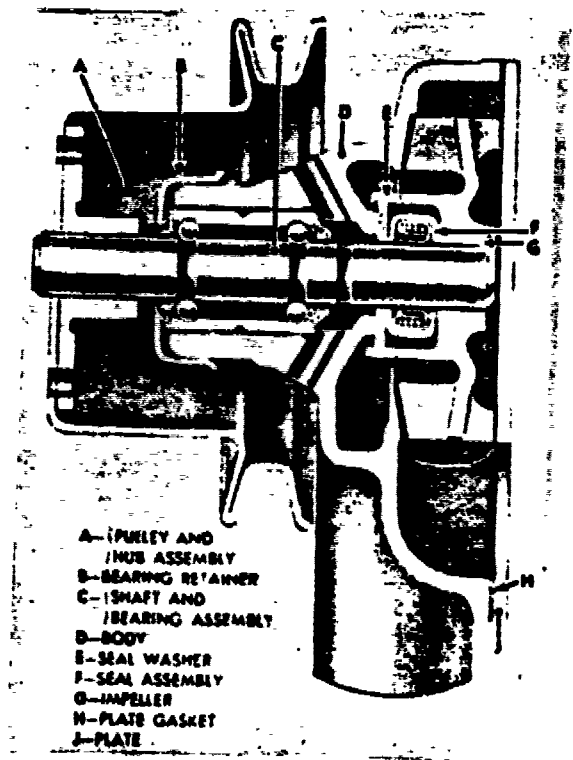

Figure 4. water pump.

(2) Advantages of the centrifugal pump over other types are that it is inexpensive, circulates great quantities of liquid for its size, and is not clogged easily by small particles of dirt. Another advantage is that it permits limited circulation by thermosiphon action even if the engine is not running.

d. Fan and shroud. The fan circulates a large volume of air through the radiator core. In addition to removing heat from the radiator, this flow of air also provides some direct air cooling for the engine. Military vehicles are often equipped with a funnel-like structure (shroud) around and behind the fan. This shroud directs the flow of air for most effective cooling (fig 5).

///
e. Thermostat.

(1) The water pump starts the coolant circulating through the system as soon as the engine is started, no matter how low the temperature. A thermostat, installed to insure quick warmup and prevent overcooling in cold weather, regulates the engine temperature by automatically controlling the amount of coolant flowing from the engine block to the radiator core.

(2) The thermostat is a heat-operated unit that controls a valve between the water jacket and the radiator. A typical thermostat is shown in figure 6 and consists of a flexible metal bellows attached to a valve. The sealed bellows, which is expandable, is filled with a highly volatile liquid such as ether. When the liquid is cold, the bellows chamber is contracted and the valve is closed (fig 7). When heated, the liquid is vaporized and expands the chamber. As the chamber expands, the valve opens (fig 8). When the engine is cold, the thermostat is closed and the coolant is recirculated through the water jacket without entering the radiator. As the engine warms up, the valve slowly opens and some of the coolant begins to flow through the radiator, where it is cooled.

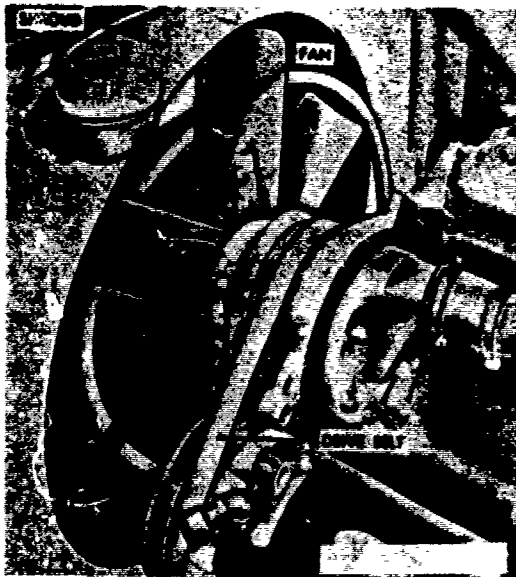

Figure 5. Cooling fan, drive belt, and shroud.

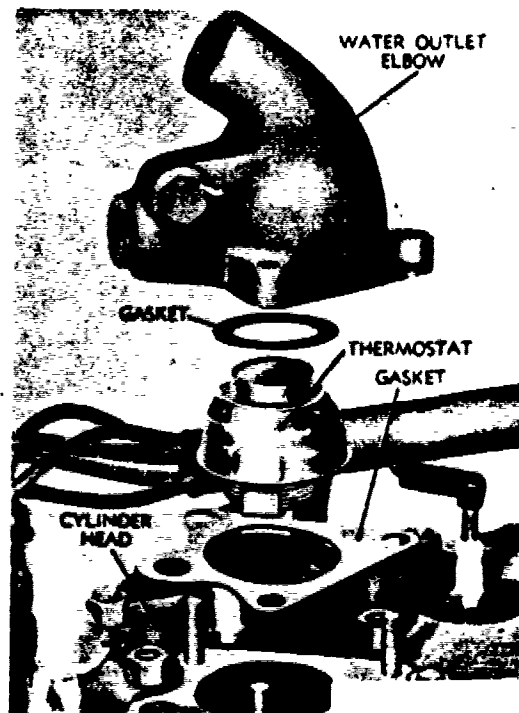
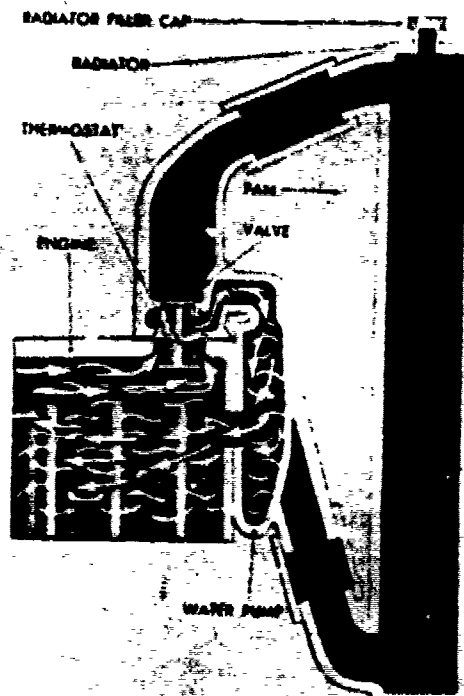

Figure 6. Thermostat.

(3) The thermostat is located between the water jacket and the radiator, usually in the housing of the cylinder head water outlet elbow. It is so constructed that if it fails to function properly, it will fail in the open position and allow free circulation of water through the engine.



ENGINE COLD—VALVE CLOSED BY THERMOSTAT ALLOWS WATER TO CIRCULATE THROUGH THE ENGINE BUT NOT THE RADIATOR

Figure 7. Thermostat closed.

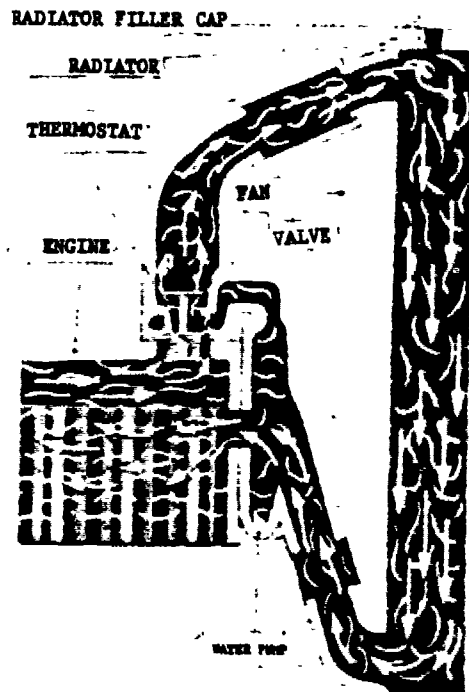

ENGINE WARM VALVE OPENED BY THERMOSTAT ALLOWS WATER TO CIRCULATE THROUGH THE ENGINE AND THE RADIATOR

Figure 8. Thermostat open.

(4) Some military vehicles are equipped with air inlet screens or shutters. They have no direct connection with the cooling system and are primarily for protection. However, they may be used to supplement or replace the action of a thermostat, and they are operated either manually by hand or automatically by a thermostatic device. The shutters restrict the flow of cool air through the radiator when the coolant is below a predetermined temperature. When the coolant reaches the proper temperature, the shutters start to open.

f. Overflow tank. When the cooling system is equipped with an overflow tank, the pressure cap is placed on the tank instead of on the radiator which will then use a plain cap. Overflow or surge tanks are special equipment for operation in hot or dry country. The coolant expands as it is heated and contracts as it cools; consequently, the level of the coolant in the radiator is constantly changing as the engine operating temperature changes. This condition is further aggravated when the temperature becomes high enough to change the water to steam, for the expansion is much greater and the pressure is also increased. However, the overflow tank makes it possible to keep the radiator full at all times. Overflow from the radiator, caused by the expansion or surging of steam vapor within the cooling system, passes through a tube to the overflow tank. The pressure cap on the overflow tank controls the pressure within the system in the same manner as described previously. The plain cap on the radiator effectively seals the radiator opening so that the only vent to the atmosphere is through the cap on the overflow tank. When the coolant cools off it contracts, and the pressure in the upper part of the radiator drops below atmospheric pressure. The pressure in the overflow tank, which is maintained above atmospheric pressure by the pressure cap, forces the liquid to return to the radiator to be recirculated through the engine.

g. Miscellaneous fittings.

(1) Drain cocks. A drain cock or removable screw-type plug is located at the bottom tank of the radiator or at the outlet to permit draining of the coolant. Similar points of drainage are provided for the engine block. In some systems, there will be a drain cock or plug in the pump housing if it is the lowest point in the system. For complete draining of all parts of the system, every coolant drain plug must be removed and every drain cock opened.

(2) Steam escape and recirculation tubes. Some overhead valve engines have a coolant tube that connects the rear end of the cylinder head with the top tank of the radiator, thus allowing the escape of steam from the water jacket without causing overflow loss. Coolant flows through this tube into the radiator even with the thermostat valve closed; therefore, to prevent overcooling of the engine during cold weather, the tube is equipped with a shutoff valve that can be closed. In another design, the tube from the rear of the cylinder head is connected into the thermostat bypass so that coolant flowing in the tube is recirculated in the water jacket without entering the radiator.

(3) Core hole plugs. Engine water jackets contain a number of round openings which are sealed by metal plugs driven into the holes. These openings in the outside walls of the cylinder block or cylinder head are necessary in the casting process, but perform no cooling system function. The core hole plugs which permanently close these openings are often incorrectly called freeze plugs. Although core hole plugs may be forced out by a solid freezeup in the water jacket, they are not a safety device that can be depended on for the prevention of freeze-cracking damage in the engine.

7. COMPONENTS OF LIQUID COOLING SYSTEMS FOR COMPRESSION IGNITION ENGINES. Our combat vehicles of today commonly employ V-6 and V-8 diesel, liquid-cooled engines.

a. V-8 engine cooling system (fig 9).

(1) The cooling system consists of two radiators, a surge tank, water pump, oil cooler, cooling fan, two thermostats, interconnecting lines, hoses, and ducts. The water pump drains water from the bottom of both radiators and the surge tank, forcing it through the oil cooler into the engine water jackets. When the engine is at normal operating temperature, the water passes through the thermostats to the radiators with a portion circulating through the surge tank. When starting a cold engine, or when the water is below operating temperature, the thermostats are closed, causing the water to flow through the bypass tube back to the water pump intake.

(2) The surge tank collects gases in the cooling system, caused by aeration of the coolant or compression leaks, and vents the gases to atmosphere when pressure exceeds 14 pounds per square inch gage (PSIG). Gases are collected from the radiators and the engine water pump elbow. The cooling fan draws air from the powerplant and radiators through deck grilles in the front of the turret deck and top of the vehicle and forces the air through the two radiators into the engine compartment. Air in the engine compartment flows on all sides of the powerplant and is exhausted through grilles on the right side of the vehicle.

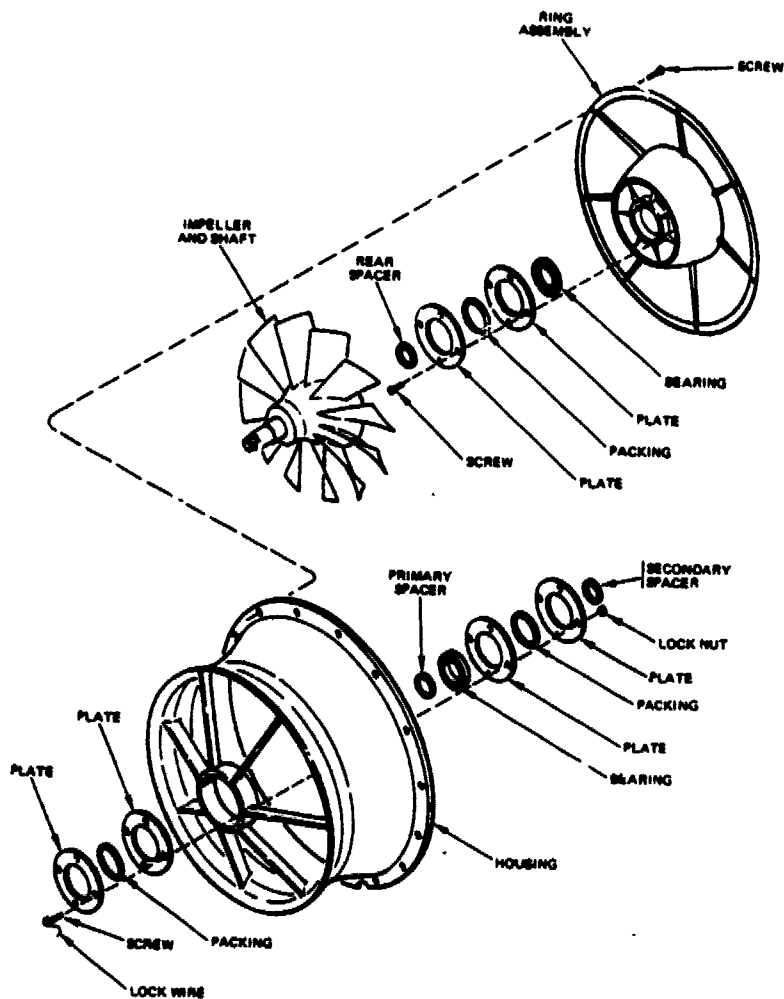

Figure 9. V-8 engine cooling fan.

b. V-6 engine cooling system (fig 10 and 11).

(1) The engine cooling system consists of a radiator, coolant pump, thermostat, oil cooler, and connecting lines and hoses. The radiator is mounted on the right side of the powerplant top cover. The pump, thermostat, and oil cooler are integral parts of the engine assembly.

(2) Coolant is drawn by the pump from the bottom of the radiator and circulated through the oil cooler, cylinder block, and cylinder heads to the thermostat housing. The thermostat is a full bypass-type with ranges of 161° F to 169° F and 181° F to 189° F.

8. AIR COOLING SYSTEMS.

a. General.

(1) Air-cooled engines, a commonplace powerplant for aircraft, are presently finding continued acceptance in military motor vehicles.

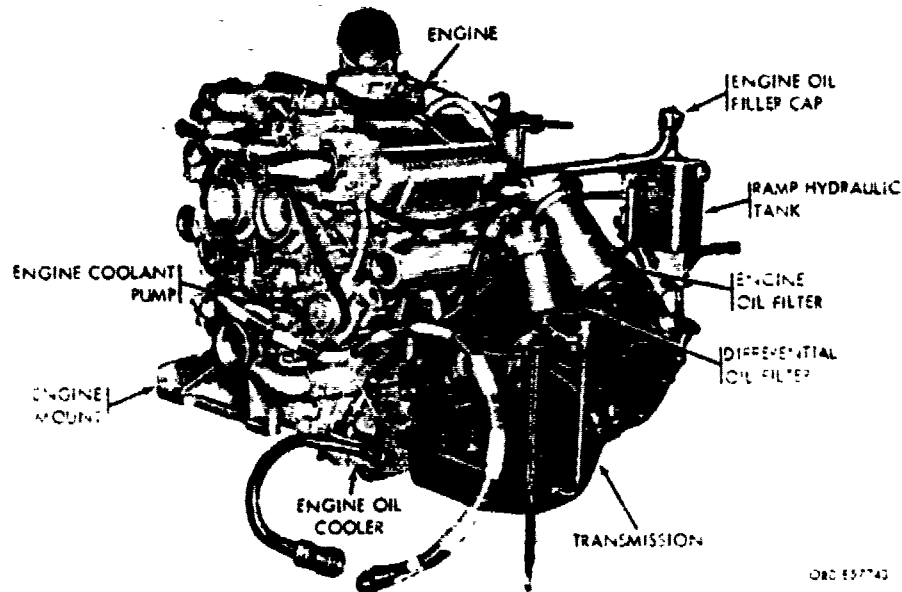

Figure 10. V-6 powerplant--left front view.

(2) Since an air cooling system does not employ a liquid coolant, it is often assumed that air alone acts as the cooling medium. However, this is not true, since the fuel and lubrication systems also help in cooling the engine. The lubrication system for an air-cooled engine often includes an oil cooler (fig 12) that circulates the oil between the engine and the cooler, and removes heat from the engine as it does so. In addition, some cooling results from the fuels contacting metal parts prior to combustion.

b. Components and functioning.

(1) There are several physical characteristics peculiar to the automotive air-cooled engine: the cylinder head and barrel are heavily finned for strength and adequate cooling; air deflectors, shrouds, or baffles direct the airflow to the cylinders and increase its velocity; and cooling fans are used to increase the volume and speed of air circulating around the cylinders.

(2) Construction of the parts required for air cooling embodies several fundamental principles of cooling. The rate of cooling is dependent upon the area exposed to the cooling medium, the heat conductivity of the metal used, the volume of metal or its size in cross section, the amount of air flowing over the heated surfaces, and the difference in temperatures between the exposed metal surfaces and the cooling air.

(3) Fans, located on top of the engines (fig 13), are driven by shafts and gears from the crankshaft, causing them to rotate at high speed. The fans circulate air through the openings around the cylinders so that cooling takes place.

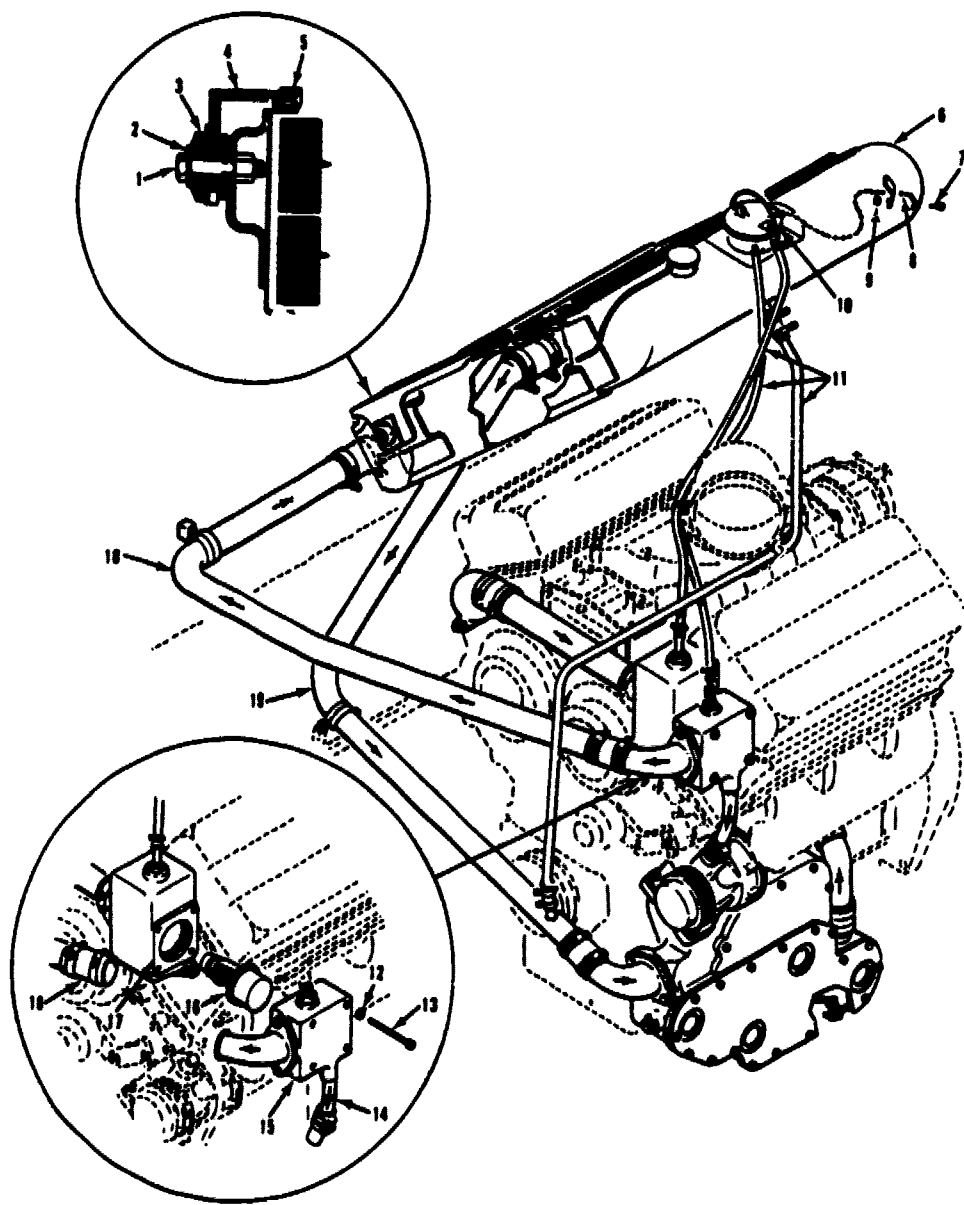

- 1-CAP SCREW
- 2-WASHER
- 3-RUBBER MOUNT
- 4-SUPPORT
- 5-SEAL
- 6-RADIATOR
- 7-SCREW
- 8-RADIATOR CAP CHAIN
- 9-NUT
- 10-RADIATOR CAP

- 11-VENT HOSE
- 12-WASHER
- 13-CAP SCREW
- 14-TUBE
- 15-THERMOSTAT HOUSING
- 16-THERMOSTAT
- 17-GASKET
- 18-TUBE
- 19-TUBE

Figure 11. V-6 engine cooling system--schematic view.

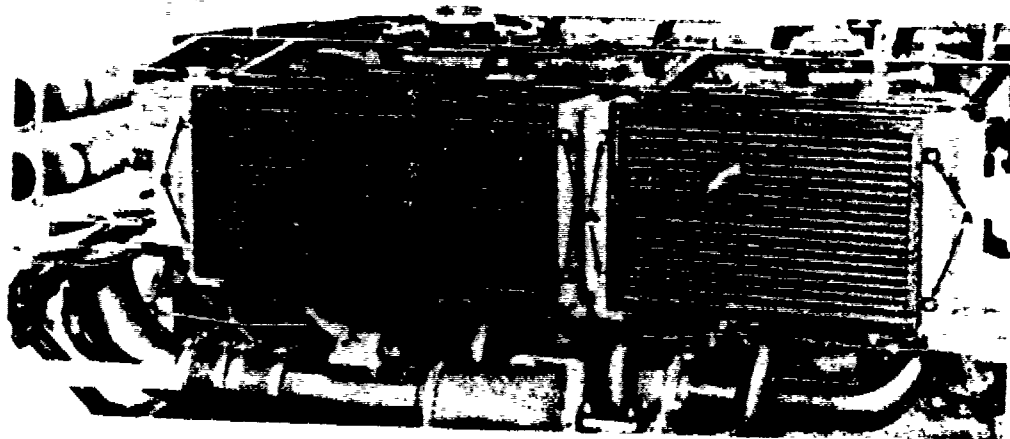

Figure 12. Oil coolers mounted on a 12-cylinder, V-type, engine.

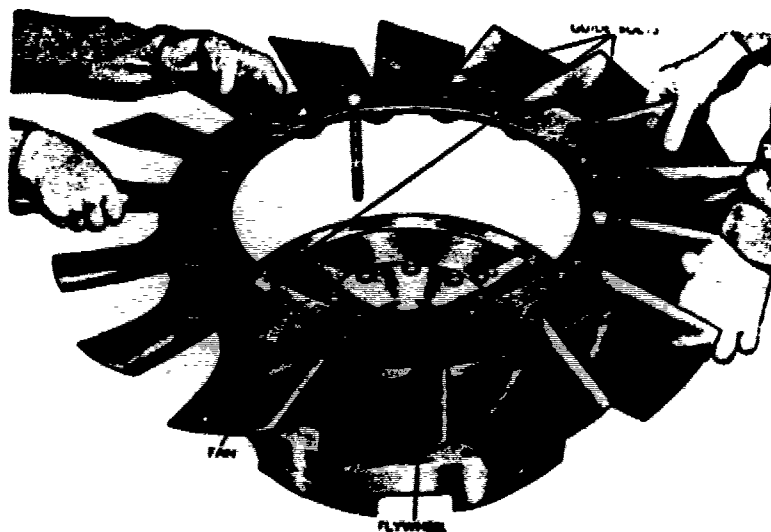

Figure 13. Radial engine flywheel with cooling fan.

(a) The cooling airflow may be either from fan to cylinders or reverse, commonly referred to as pressure or suction cooling. Excellent results may be obtained by either method, but suction has the disadvantage of requiring about one percent more of the gross engine power, due to the increased air temperature to the fan, and the lack of turbulence that is ordinarily found at the fan outlet.

(b) For a given cylinder design, the operating metal temperatures depend on the cooling air quantities supplied and the effectiveness of the cylinders' utilization of this air. The cooling air requirements can be varied by changes in the fin area; e.g., high output aircraft engines have about twice the fin area of the vehicle engines. In this case, the extra area is exploited to obtain increased output. If there were need to reduce the cooling airflow on vehicle engines, a considerable saving on fan power could be effected by increasing the fin area, though at an increased cost of the cylinders. The finning used in most vehicle engines is considered neither expensive nor difficult to manufacture.

(c) The first consideration, when installing an air-cooled engine, is the proper path for the cooling air and, at the same time, maximum accessibility. The cooling system should not have constricted air entrances or exit ducts, and velocities of 45 feet per second are ordinarily recommended. The air may be discharged from the fan into a plenum chamber ahead of the cylinder. An equally effective arrangement incorporates, as a part of the engine, all ducting between the fan and powerplant. The former method has the advantage of permitting more accessibility to the engine when the installation space is limited. For military vehicles, it is necessary to eliminate belt drives for the fan and provide a method of unloading the fan for underwater operation so as not to overload the fan drive. A centrifugally actuated fan drive friction clutch gives the required action. An alternative method is an eddy-current electric drive, which has the additional advantage of providing temperature control for the cylinders. This is done by using a temperature-sensitive element on the cylinders which controls current to the clutch, thus regulating the fan speed to suit the cylinder temperature.

(4) With a fin depth of 1 inch, the metal temperature at the combustion chamber wall is 500° F and the average fin temperature is 380° F. A point of interest is the high temperature of the fin metal out to the tip, which illustrates a basic point of superiority of the air-cooled engine over the liquid-cooled. Because of the higher temperature differential between the cooling air and the fin metal in the air-cooled engine, the cooling air required to maintain safe temperatures is about one-half that required for a comparable liquid-cooled engine.

(5) Oil coolers play an important part in keeping the engine from overheating. The heated oil from the engine passes through the cooler, which acts much like the radiator used with liquid-cooled engines. Here, the oil picks up heat from the engine and is cooled by the radiator. Some engines use two such oil coolers. The coolers cool both engine and transmission oils, having separate cores for each. The fans used with the oil coolers are driven from the driving gear in the transmission through a gear train and electrically operated clutches in the front fan shrouds. The clutches serve as a means of regulating oil temperature since they engage only when the temperature exceeds a certain value. When this value is exceeded, thermostats close and cause the clutches to engage. The fans then operate. This permits faster engine warmup since the oil cooler fans do not operate when the engine is cold.

c. Comparison of air- and liquid-cooled engines.

(1) Plumbing difficulties. Freedom from plumbing difficulties is the obvious advantage of air-cooled engines. The average water-cooled engine coolant system has 4 to 40 hose clamps, with passenger cars averaging about 6. These are all potential points of leakage, and, together with the water pump and the jacket plugs and gaskets, they form literally hundreds of places for leakage trouble. Service records show that about 20 percent of service interruptions in military vehicles are caused by cooling system faults and nearly all of these are of the type which can be eliminated by the air-cooled engine.

(2) Antifreeze troubles.

(a) Antifreeze troubles are listed separately since they are such a severe problem in a great many regions of the world. From the military view the antifreeze problem is particularly troublesome, but commercial operations are equally plagued with the complaint. Some fleet operators let engines idle for a few hours, or drain the system, rather than contend with the expense and uncertainty of ordinary antifreeze protection. In addition to the freezing problem, liquid-cooled engines suffer from clogging of the radiator and other cooling system components.

(b) Clogging of air-cooled cylinder fins with dirt is not often encountered, even in the extremes of military use. This is because the fins are so closely associated with the shock of combustion which shakes ordinary deposits loose. An exception to this occurs in amphibious vehicle service when air cooling fans are sometimes blocked by waves breaking over the engine compartment, thus forcing salt water through the fins. Some salt remains on the fins until a buildup results in clogging. A fair percentage of fin area can be clogged in this manner without any interference with engine operation.

(3) Weight. The air-cooled engine is basically lighter, especially when built in the horizontally-opposed arrangement. Studies show that air-cooled engines have less volume of metal in the cylinder from the crankcase out to the tip of the cylinder. In addition, most of this is aluminum.

(4) Fan power.

(a) There is ample evidence to show that air-cooled engines can be made so that less power is wasted in cooling. Where there is no assist from forward motion of the vehicle, the engine power used for cooling is in the region of 5 percent of the gross power. At a vehicle speed of about 70 miles per hour, no cooling power would be required by the fan.

(b) Since the quantity of air required for cooling an air-cooled engine is about one-half the quantity required for a water-cooled engine, smaller ducts to and from the engine are used. This is a distinct advantage in most vehicles, since less area is required inside the vehicle.

(5) Serviceability. Serviceability (ease and cost of maintenance) is about equal in most evaluations. The advantage of individual cylinder construction is partly offset by the crankshaft inaccessibility.

(6) Long life. The air-cooled engine has a background of service life information established in the aircraft industry and in military use in this country and in Europe during the last 20 years, including about 30,000,000 horsepower installed in tanks in World War II. This record indicates that the air-cooled engine is equal to the present-day liquid-cooled vehicle engine.

(7) Noise. Noise is generally regarded as more severe in air-cooled engines than in liquid-cooled engines, since it is claimed that the water and extra metal density of the liquid-cooled engine give sound suppression.

(8) Cold weather operation. Air-cooled engines operate more favorably than liquid-cooled engines in cold weather and during the warmup process because there is less thermal lag, due to less mass. In addition, the warmer intake port in the cylinder head results in fewer warmup difficulties and better cold operation. Sludge difficulties in the oil system appear to be much less in air-cooled engines, due to faster warmup and higher temperatures in the lower region of the piston travel and in the valve spring chamber.

(9) Antidetonation quality. Detonation is about equal at equal power output conditions, although the air-cooled engine will probably have lower compression ratio than the liquid-cooled engine.

(10) Fuel consumption. There is little difference between the two engine types on the basis of fuel consumption when they are developed to use the same octane fuel. Equality of output and fuel consumption is obtained at lower compression ratios in the case of the air-cooled engine, but this is of little practical significance.

EXERCISE

- 56. Which antifreeze solution provides maximum protection from freezing temperatures?
 - a. 60 percent water and 40 percent methyl alcohol
 - b. 40 percent water and 60 percent ethylene glycol
 - c. 60 percent water and 40 percent ethylene glycol
- 57. When should used antifreeze solution be discarded?
 - a. When the solution loses its resistance to freezing after a short period of time
 - b. When the ethylene glycol evaporates to a point where the solution's viscosity thickens
 - c. When the solution loses its corrosion inhibiting properties after prolonged use
- 58. At what temperature range is a coolant other than the ethylene glycol solution required?
 - a. +25° F to +90° F
 - b. +50° F to -30° F
 - c. -60° F to +25° F
- 59. What advantage is gained by pumping engine coolant from the bottom instead of from the top of a radiator?
 - a. The expansion and contraction of the water aids the pump
 - b. The thermostat can be designed as a one-way valve
 - c. The coolant remains around the valve seats for a longer time
- 60. What is the purpose of the baffle in the upper tank of a radiator?
 - a. To prevent overfilling of the cooling system
 - b. To assist in distributing the coolant to the water tubes
 - c. To regulate the coolant flow to the lower radiator tank



121

61. The passages through which the coolant flows from the cylinder block into the cylinder head of an engine are called
 - a. water circulation tubes.
 - b. water jackets.
 - c. water transfer ports.

62. What is gained by the use of a pressure cap on a radiator?
 - a. The boiling point of the coolant is raised
 - b. The requirement for a surge tank is eliminated
 - c. The thermostat will open at a lower temperature

63. Which statement is TRUE in a comparison of the pressure and suction types of air cooling of engines?
 - a. The pressure type requires more power to be driven
 - b. The suction type does not generate turbulence at the fan outlet
 - c. The pressure type has a higher air temperature at the fan

64. What prevents air-cooled cylinder fins from clogging with dirt?
 - a. The shock of combustion
 - b. The extreme length of the fins
 - c. The shape of the shroud

65. In a comparison of liquid- and air-cooled engines, which statement is TRUE?
 - a. Air-cooled engines are more difficult to maintain
 - b. Air-cooled engines are heavier
 - c. Liquid-cooled engines are less noisy

EXERCISE RESPONSE LIST

**ORDNANCE SUBCOURSE 607
ENGINE PRINCIPLES**

DECEMBER 1975

**DEPARTMENT OF ARMY WIDE TRAINING SUPPORT
US ARMY ORDNANCE CENTER AND SCHOOL
ABERDEEN PROVING GROUND, MARYLAND**

ANSWER SHEET

(For Student Use Only. Do Not Return.)

	a	b	c		a	b	c		a	b	c		a	b	c		a	b	c
1.	104	901	638	41.	437	622	333	81.	246	408	480	121.	628	346	618	161.	428	613	114
2.	223	867	886	42.	348	138	274	82.	388	440	634	122.	484	288	388	162.	201	682	443
3.	421	388	243	43.	277	184	847	83.	888	388	122	123.	217	888	438	163.	888	373	888
4.	241	483	827	44.	638	438	888	84.	238	638	338	124.	37	888	138	164.	188	481	238
5.	378	188	812	45.	113	488	382	85.	888	282	271	125.	888	388	281	165.	387	272	884
6.	888	118	427	46.	622	387	288	86.	178	884	488	126.	111	888	331	166.	888	388	174
7.	882	288	428	47.	181	842	412	87.	434	188	878	127.	833	282	478	167.	343	181	888
8.	638	187	483	48.	388	882	283	88.	881	383	184	128.	218	438	828	168.	128	618	488
9.	878	143	881	49.	888	378	418	89.	228	474	872	129.	411	188	871	169.	828	246	314
10.	847	888	342	50.	118	483	284	90.	488	138	382	130.	828	188	388	170.	487	882	288
11.	288	678	231	51.	184	418	833	91.	371	838	282	131.	388	887	278	171.	288	433	648
12.	638	488	238	52.	828	188	828	92.	813	288	448	132.	144	487	888	172.	818	188	381
13.	428	388	638	53.	311	888	488	93.	188	884	843	133.	478	882	123	173.	473	888	248
14.	183	112	828	54.	187	238	323	94.	844	282	484	134.	882	288	488	174.	211	888	488
15.	118	338	178	55.	384	442	277	95.	387	618	181	135.	228	388	888	175.	182	381	881
16.	618	278	482	56.	881	388	888	96.	188	374	888	136.	188	441	388	176.	388	488	888
17.	238	382	834	57.	677	288	428	97.	887	127	332	137.	472	888	128	177.	638	288	188
18.	181	488	382	58.	388	482	147	98.	418	618	212	138.	388	187	678	178.	448	187	848
19.	821	381	388	59.	318	638	488	99.	247	481	887	139.	634	388	244	179.	183	842	312
20.	838	378	428	60.	184	883	288	100.	328	881	188	140.	678	221	401	180.	234	888	488
21.	488	134	882	61.	388	678	477	101.	188	381	614	141.	287	888	888	181.	678	283	888
22.	841	482	242	62.	28	387	188	102.	883	131	488	142.	384	888	188	182.	382	438	148
23.	328	133	887	63.	287	648	848	103.	431	887	288	143.	841	287	488	183.	674	317	248
24.	283	488	637	64.	422	138	888	104.	281	888	612	144.	183	888	388	184.	188	348	684
25.	248	328	288	65.	818	884	417	105.	881	288	318	145.	648	222	287	185.	328	883	281
26.	182	288	428	66.	148	488	218	106.	118	887	238	146.	228	448	814	186.	622	178	484
27.	288	881	643	67.	888	288	378	107.	881	222	418	147.	418	138	888	187.	882	288	618
28.	673	388	432	68.	821	177	888	108.	414	188	888	148.	888	388	188	188.	288	617	327
29.	837	213	288	69.	488	883	328	109.	388	811	172	149.	284	884	488	189.	688	413	187
30.	182	284	117	70.	134	487	884	110.	887	438	328	150.	434	188	383	190.	377	673	132
31.	881	471	341	71.	388	448	178	111.	148	381	888	151.	848	218	848	191.	138	318	481
32.	278	617	324	72.	288	8	387	112.	384	887	188	152.	128	883	284	192.	688	188	378
33.	881	677	282	73.	674	184	618	113.	618	118	888	153.	321	483	678	193.	484	281	828
34.	288	678	288	74.	887	288	882	114.	148	447	288	154.	171	384	828	194.	844	488	232
35.	347	672	128	75.	228	888	181	115.	482	328	623	155.	883	227	484	195.	287	638	648
36.	188	884	278	76.	372	141	888	116.	328	888	484	156.	438	882	148	196.	888	283	488
37.	178	883	481	77.	648	888	218	117.	188	224	388	157.	888	182	337	197.	318	188	632
38.	488	884	188	78.	444	228	313	118.	888	884	142	158.	318	632	278	198.	137	611	348
39.	218	634	482	79.	888	888	173	119.	388	121	848	159.	214	478	671	199.	888	383	288
40.	487	627	388	80.	188	344	631	120.	188	478	273	160.	678	182	348	200.	478	688	128

**RESPONSE
NUMBER****RESPONSE***

101	CORRECT. The snaprings will prevent the pin from working out against the sides of the cylinder.
103	CORRECT. The engine mounting supports are an integral part of the crankcase.
104	Para 2d
109	Para 6b(4)
110	Para 7d(3)
112	Para 5b
113	CORRECT. The piston rings are the most important engine lubrication points.
116	Para 4b(5)(b)
117	CORRECT. More power can be obtained from the same amount of fuel.
119	Para 7b
124	Para 12
129	CORRECT. This special shaped piston promotes even combustion for a variety of fuels.
133	Para 14c
138	Para 8c(2)(b)
143	Para 10g(1)
147	CORRECT. Arctic grade antifreeze is used when temperature is below -55° F.
152	Para 2h(1)
156	Para 4c
164	Para 5d(2)
166	Para 7a
167	Para 6d(4)
178	Para 7b
179	Para 6a(2)
188	Para 6c(2)(c)
191	Para 4a(2)

*Note. - If your response is not marked CORRECT, refer to the paragraph, figure, or table listed for the correct answer.

125

192 Para 3d(1)
194 Para 6b(2)
195 Para 6e(3)
197 Para 10c
204 Para 4b(5)(b)
206 Para 3b
207 Para 8b(3)(a)
213 Para 3c(1)(b)
215 Para 5a
223 Para 3c
227 Para 6f(4)
231 Para 2a
235 Para 2e
236 Para 8b
239 CORRECT. At higher temperatures problems may exist.
241 Para 3a
242 CORRECT. The main bearing is provided with lip or thrust faces.
243 CORRECT. For each stroke of the piston the crankshaft will revolve once.
248 Para 17
253 Para 4a(5)
256 CORRECT. Gasoline engines operate on high octane, high volatile fuels, which can only be produced from a small area of the available fuel spectrum.
259 Para 3c(2)
264 Para 3d(1)
268 Para 6b(2)
274 CORRECT. Oil adhering to a rotating shaft is carried along by the motion of the shaft.
276 Para 7c
277 CORRECT. And there can be an innumerable variation or combination of the three conditions.
278 Para 4c
279 CORRECT. Only the portion that is vaporized at any interval will burn.

126

284 CORRECT. It also permits the engine to operate at higher temperatures.

288 CORRECT. Also, this would simplify servicing and training procedures.

289 Para 2a

290 CORRECT. Rack position is obtained when the piston is at TDC and BDC.

292 Para 3e(1)(c)

293 Para 15f

295 CORRECT. In addition, more air is actually available for combustion.

296 Para 2j(1)

298 CORRECT. One of the reasons the diesel engine was selected was because of the type of fuel.

299 CORRECT. This system can also be found in the opposed engine.

304 CORRECT. Very little filtering of oil occurs when oil is cold.

309 Para 3a

311 Para 6g(2)

316 CORRECT. When the coolant is heated in the jackets of the engine it expands and becomes lighter.

323 Para 6d(4)

324 Para 3e(1)(b)

326 Para 14c

330 Para 17

333 CORRECT. However, to overcome rolling, friction consumes a lesser amount of power and produces a lesser amount of heat.

336 CORRECT. It will fit the cylinder whether the pistons are hot or cold.

341 Para 3e(1)(a)

342 CORRECT. The mechanical efficiency is the relationship between the power produced in and power delivered by the engine.

347 Para 4b and d

349 Para 2g

350 CORRECT. The best protection from freezing is obtained from a solution of 40 percent water and 60 percent ethylene glycol.

356 Para 6c(3)(b)

- 358 CORRECT. Also, from the connecting rod bearings to the piston pin bearings.
- 362 Para 9b(3) and fig 12
- 367 Para 6b(4)
- 369 CORRECT. The crankshaft may have one or more throws.
- 375 Para 7a
- 378 CORRECT. This is also true with 1 and 8.
- 379 Para 4b(1)(c)
- 382 CORRECT. The rings do not form a perfect seal and should be staggered during installation.
- 389 Para 4c(1)
- 390 Para 3b(4)
- 391 Para 11a
- 392 Para 3a(2)
- 393 Para 6a(2)
- 394 Para 2i
- 396 CORRECT. The head is threaded and is screwed and shrunk onto the cylinder barrel while the head is heated.
- 397 Para 4a(1)
- 402 Para 4c(1)
- 403 Para 5
- 408 Para 3a(2)
- 409 Para 2e
- 412 Para 4a(2)
- 415 CORRECT. You may also find the LO number in the TM that covers PM services.
- 416 CORRECT. This is so that it will almost touch one side of the pump housing.
- 417 CORRECT. There is generally less noise in the liquid-cooled engine than in the air-cooled engine.
- 420 Para 9c and fig 12
- 421 Para 3a
- 422 CORRECT. Amphibious vehicles operating in salt water often will have salt remain on fins until a buildup results in clogging.
- 423 Para 2h(1)

128

425 CORRECT. Antifreeze solution should be checked and changed when needed.

426 Para 11 and fig 14

427 Para 7d(3)

429 Para 4e(1)

432 Para 3b(4)

437 Para 2e(1)

442 Para 6f(4)

452 CORRECT. Also, the result is a more perfect fit between piston and cylinder walls.

457 Para 6c(3)(b)

463 CORRECT. We can also relate to this as horsepower.

465 Para 6c(2)(c)

471 CORRECT. With its special intake port, induction air is given as swirling motion which persists into the combustion chamber.

477 CORRECT. The water passages through which coolant flows from the cylinder block are called transfer ports.

482 Para 5a

483 Para 3a

485 CORRECT. With the camshaft placed in the cylinder block the distance would be long.

486 Para 12

490 Para 9b(3) and fig 12

491 CORRECT. This engine can also operate on a wide range of hydrocarbon fuels.

492 Para 13b

493 CORRECT. This force is sufficient to remove any vapor out of the crankcase.

496 CORRECT. Another way to say this would be to prevent metal-to-metal contact in moving parts.

498 CORRECT. This can be through high engine temperatures or through fuel dilution.

500 Para 4b(1)(c)

501 CORRECT. The link between the crankshaft and piston that transmits up-and-down motion is called the connecting rod.

504 Para 8c(7)

505 Para 6g(2)

129

- 508 Para 8c(2)(b)
- 510 Para 7c
- 520 CORRECT. This will reduce load-carrying ability of the lubricant.
- 521 Para 11a
- 522 Para 4a(1)
- 523 Para 2e(1)
- 524 Para 8b
- 527 CORRECT. Intake, compression, power, and exhaust, in that order
- 529 Para 5b
- 533 Para 5d(2)
- 536 Para 2d
- 537 Para 3c(1)(b)
- 539 Para 3a(2)
- 541 Para 13b
- 545 CORRECT. Suction requires about 1 percent more of the gross engine power.
- 547 Para 11c
- 553 CORRECT. It also prevents coolant from being thrown out of the radiator.
- 562 Para 9c and fig 12
- 563 Para 6a(2)
- 570 Para 6a(2)
- 572 Para 4b and d
- 573 CORRECT. This is one of many that meet Army requirements for this engine.
- 577 CORRECT. Burning of evaporated fuel prevents an accumulation of larger amounts of vaporized fuel.
- 578 CORRECT. Prior to the use of iron alloy, gray cast iron was used.
- 579 CORRECT. Horsepower depends on both speed and torque.
- 581 Para 3e(1)(a)
- 582 CORRECT. The flywheel stores up energy of rotation when the instantaneous torque on the crankshaft is greater than average.
- 584 CORRECT. As air passes over the rotating regenerators, it will heat up.

590 Para 2b

591 CORRECT. This type of chamber requires higher injection pressure.

594 CORRECT. Through this part air continues to supply oxygen to the slowly evaporating fuel.

595 CORRECT. At the top of the compression stroke, both the intake and exhaust valves are closed to prevent fuel and air mixture from escaping.

597 CORRECT. The heat is transferred to the adjacent metals.

612 CORRECT. This is the most common method.

615 Para 8c(7)

617 Para 3e(1)(b)

627 CORRECT. It reduces exhaust noise so that no muffler is required.

628 Para 11 and fig 14

629 Para 6e(3)

630 Para 10c

631 Para 2b

634 CORRECT. With this unit the power output is the same regardless of fuel used.

635 CORRECT. They can also be easily replaced.

636 Para 4e(1)

637 Para 15f

638 Para 5

639 Para 2g

642 CORRECT. A partly filled crankcase may result in inadequate lubrication.

643 Para 2j(1)

647 Para 2i

648 Para 8b(3)(a)

657 Para 3c

661 Para 10g(1)

662 Para 4a(5)

677 Para 3b

679 Para 3c(2)

13/85

Para 11c

690

CORRECT. This is true because the cylinders are laid on their sides, which reduces the overall height and headroom for mounting the engine.

691

Para 3e(1)(c)

699

Para 3a(2)

CORRESPONDENCE COURSE
of the
US ARMY ORDNANCE
CENTER AND SCHOOL



EXAMINATION VERSION I

Ordnance Subcourse No 607 Engine Principles
Credit Hours One
Objective. To test your knowledge of all material presented in this subcourse.
Suggestions. Before starting this examination, it is suggested that you review all lessons studied in this subcourse.
Texts. All Attached Memorandums used with this subcourse.
Materials Required None

REQUIREMENT--25 MULTIPLE CHOICE QUESTIONS--Weight 100--All items are weighted equally.

1. When aluminum heads are used on gasoline air-cooled engines, what is required that is NOT needed on engines using cast iron heads?
 - a. Steel inserts in the spark plug holes
 - b. Noncorrosive steel on the intake side of the heads
 - c. Sodium filled intake valves
 - d. Aluminum bronze alloy head gaskets
2. Ethylene glycol antifreeze solution should be drained from cooling systems when operating vehicles in warm weather because it
 - a. evaporates rapidly.
 - b. boils at a lower temperature than water.
 - c. loses its rust inhibiting property.
 - d. is less efficient than plain water for dissipating heat.
3. In what way is a liquid cooling system that utilizes a centrifugal pump more advantageous than systems that incorporate other types of pumps?
 - a. Limited coolant circulation continues after the engine has stopped running
 - b. Less power is required to drive the pump at high speeds
 - c. Simplified construction is required to mount the cooling fan
 - d. Adjustable impeller blades provide for a variation of coolant volume

OS 607, E-P1
December 1975

4. What is the MOST essential property of diesel fuel?
 - a. Low viscosity
 - b. Good ignition quality
 - c. High pour point
 - d. Cleanliness
5. What is gained by using cylinder liners in large motor vehicle engines in comparison to a cast on bloc cylinder block?
 - a. Engine will operate more efficiently
 - b. Cooling system can be smaller
 - c. Compression ratio can be higher
 - d. Cost of engine overhaul is less
6. How does the Continental hypercycle differ from combustion chamber principles of other compression ignition systems?
 - a. Fuel spray entering combustion chamber is shaped to fit the chamber
 - b. Fuel is sprayed onto the walls of a spherical combustion chamber
 - c. Fuel is injected directly onto the top of the piston
 - d. Fuel is injected directly into an energy cell
7. What type of engine uses a crankshaft where throws 2 and 3 are on the same plane and on the same side of the shaft?
 - a. 8-cylinder, in-line
 - b. 8-cylinder, V-type
 - c. 6-cylinder, in-line
 - d. 4-cylinder, in-line
8. Which 4-stroke-cycle engine will produce a maximum power overlap of 25°?
 - a. 2-cylinder, in-line
 - b. 4-cylinder, V-type
 - c. 6-cylinder, in-line
 - d. 8-cylinder, V-type
9. If two layers of oil molecules separate the metals of a shaft and a bushing, what degree of lubrication exists?
 - a. Partial
 - b. Insufficient
 - c. Boundary
 - d. Sufficient
10. What is indicated if the size of an engine is designated as 3 x 4?
 - a. Compression ratio is 12:1
 - b. Crankshaft throws are offset 2 inches from the center of the shaft
 - c. Bore of the cylinder at the largest point is 4 inches
 - d. Diameter of the piston is 3 inches
11. What is an advantage of a piston having a slipper-type skirt over one with a trunk-type skirt?
 - a. Greater strength
 - b. Better control over the oil film
 - c. Less friction on the cylinder walls
 - d. Larger contact with the cylinder walls

- 134
12. Which is characteristic of the combustion process of a diesel engine?
 - a. The pressure on the piston is limited to the first half of the power stroke
 - b. The combustion is continuous during the entire length of the power stroke
 - c. The volume of the mixture remains the same during the combustion process
 - d. The combustion is greatest while the piston is at the bottom part of its travel
 13. Which is an example of the classification of a diesel engine?
 - a. Medium speed
 - b. 6-cylinder, V-type
 - c. Air-cooled
 - d. Supercharged
 14. More power is required to drive the fan on a suction-type air-cooled system than on a pressure-type because
 - a. the temperature of the air at the fan is lower.
 - b. this type moves the air at a higher velocity.
 - c. there is no turbulence at the fan outlet.
 - d. the shrouds deflect the air at various angles.
 15. Which BEST indicates the operation if the piston is at top dead center and the crankshaft can move 15° to 20° without causing the piston to move UP or DOWN?
 - a. Salient position
 - b. Valve timing
 - c. Rack position
 - d. Intake valve timing
 16. Which occurs in a 2-stroke-cycle gasoline engine?
 - a. A partial vacuum is created in the cylinder during the downward stroke of the piston
 - b. When the exhaust port is opened, pressure in the crankcase is higher than that in the cylinder
 - c. The turbulence created by the exhausting of burned gases aids in the mixture intake
 - d. The fuel-air mixture enters the cylinder after the upward movement of the piston closes the exhaust port
 17. What lubrication system helps lubricate the piston and cylinder walls by using the return of oil that lubricates the piston pins?
 - a. splash
 - b. Splash and force-feed
 - c. Force-feed
 - d. Full force-feed
 18. What type of oil pump is MOST frequently used in engine lubrication systems?
 - a. Rotor
 - b. Gear
 - c. Vane
 - d. Plunger

19. Engines are MOST commonly classified by type of
- valve arrangement.
 - cylinder arrangement.
 - cooling.
 - fuel.
20. What antifreeze solution will provide the BEST protection from freezing?
- 20% water and 80% antifreeze compound
 - 50% water and 50% antifreeze compound
 - 40% water and 60% antifreeze compound
 - 60% water and 40% antifreeze compound
21. What type of friction requires the least force to overcome?
- Fluid
 - Static
 - Sliding
 - Rolling
22. What will decrease the knock in a diesel engine?
- Increase compression ratio
 - Decrease compression ratio
 - Decrease volume of intake air
 - Increase ignition lag
23. What is the primary function of engine lubricating oils?
- Assist in carrying away engine heat
 - Clean engine parts
 - Reduce friction between moving parts
 - Prevent blowby of combustion gases
24. If the crankshaft of a 4-stroke-cycle gasoline engine rotates two complete revolutions in a clockwise direction, which statement is TRUE?
- The camshaft will rotate 360°
 - Each piston will complete two power strokes
 - The camshaft will rotate in a clockwise direction
 - Each piston will move up and down once
25. What is the MOST important advantage of automotive vehicles equipped with diesel engines over those equipped with gasoline engines?
- Increased volumetric efficiency
 - Better fuel economy
 - Less fire hazard
 - Increased reliability.