

DOCUMENT RESUME

ED 099 501

CE 002 578

TITLE Module Four: Measuring Current and Voltage in Series
 Circuits; Basic Electricity and Electronics
 Individualized Learning System.

INSTITUTION Bureau of Naval Personnel, Washington, D.C.

REPORT NO NAVPERS-94558-4a

PUB DATE Jan 72

NOTE 134p.; Photographs are marginally reproducible. For
 other modules in the series, see CE 002 573-589

EDRS PRICE MF-\$0.75 HC-\$6.60 PLUS POSTAGE

DESCRIPTORS Course Content; *Electricity; *Electronics;
 Individualized Instruction; Individualized Programs;
 Industrial Education; Military Training; Post
 Secondary Education; *Programed Instruction;
 *Programed Materials; Study Guides; Trade and
 Industrial Education; Units of Study (Subject
 Fields)

ABSTRACT

The module covers the characteristics of series circuits, how to use the multimeter as an ammeter and voltmeter, and how to make current and voltage measurements in series circuits. This module is divided into three lessons: measuring current in a series circuit, voltage in a series circuit, and using the multimeter as a voltmeter. Each lesson consists of an overview, a list of study resources, lesson narratives, programed instructional materials, and lesson summaries. (Author/BP)

U.S. DEPARTMENT OF HEALTH
EDUCATION & WELFARE
NATIONAL INSTITUTE OF
EDUCATION
THIS DOCUMENT HAS BEEN REPRODUCED
EXACTLY AS RECEIVED FROM
THE PERSON OR ORGANIZATION
ORIGINATING IT. POINTS OF VIEW OR OPINIONS
STATED DO NOT NECESSARILY REPRESENT
THE OFFICIAL POSITION OR POLICY OF
THE NATIONAL INSTITUTE OF
EDUCATION.

**BASIC ELECTRICITY AND ELECTRONICS
INDIVIDUALIZED LEARNING SYSTEM**

MODULE FOUR

**MEASURING CURRENT AND
VOLTAGE IN SERIES CIRCUITS**

Study Booklet

BUREAU OF NAVAL PERSONNEL

January 1972

F002578

O V E R V I E W

MODULE FOUR

MEASURING CURRENT AND VOLTAGE IN SERIES CIRCUITS

In this module you will learn the characteristics of a series circuit, how to use the multimeter as an ammeter and a voltmeter, and how to make current and voltage measurements in series circuits.

For you to more easily learn the above, this module has been divided into the following three lessons:

- Lesson I. Measuring Current in a Series Circuit
- Lesson II. Voltage in a Series Circuit
- Lesson III. Using the Multimeter as a Voltmeter

Do not be concerned at this time with the names or terms unfamiliar to you. Each will become clear as you proceed. However, if you have any questions, do not hesitate to call your instructor. Turn to the following page and begin Lesson I.

BASIC ELECTRICITY AND ELECTRONICS
INDIVIDUALIZED LEARNING SYSTEM



MODULE FOUR
LESSON I

Measuring Current in a Series Circuit

Study Booklet

OVERVIEW

LESSON I

Measuring Current in a Series Circuit

In addition to the Module Overview, as you start each lesson, you will find a lesson overview like this one. It is merely an outline of what you will study and learn to do in each lesson. In this lesson you will study and learn about the following:

- what a series circuit is
- a brief word about parallel circuits
- using a multimeter as an ammeter
- determining current is common in a series circuit
- practical measurement of DC current

Each of the above topics will be discussed in the order listed. As you proceed through this lesson, observe and follow directions carefully.

BEFORE YOU START THIS LESSON, PREVIEW THE LIST OF STUDY RESOURCES ON THE NEXT PAGE.

LIST OF STUDY RESOURCES
LESSON I

Measuring Current in a Series Circuit

To learn the material in this lesson, you have the option of choosing, according to your experience and preferences, any or all of the following:

STUDY BOOKLET:

Lesson Narrative
Programmed Instruction
Lesson Summary

ENRICHMENT MATERIAL:

NAVPERS 93400A-1a "Basic Electricity, Direct Current."
Fundamentals of Electronics. Bureau of Naval Personnel.
Washington, D.C.: U.S. Government Printing Office, 1965.

AUDIO-VISUAL:

Sound/Slide Presentation - "Measuring Current With a Multimeter."

Remember, you may study any or all of these that you feel are necessary to answer all Progress Check questions correctly. Do not forget that in one sense of the word your instructor is a living resource; perhaps the best. Call him if you have any kind of a problem.

YOU MAY NOW STUDY ANY OR ALL OF THE RESOURCES LISTED ABOVE. YOU MAY TAKE THE PROGRESS CHECK AT ANY TIME.

NARRATIVE
LESSON 1

Measuring Current in a Series Circuit

What a Series Circuit Is

A series circuit has only one path for current flow. In the study of electricity, when we say components are connected in series, we mean they are connected in line one right after the other.

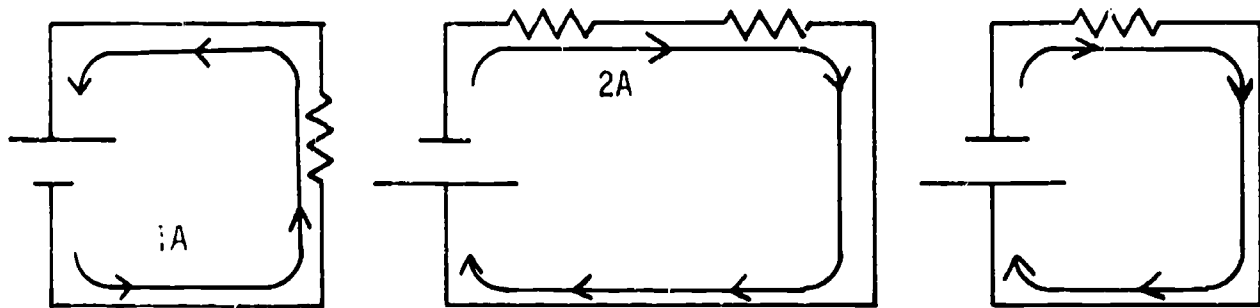

In each of the above circuits, you can see that current has only one path it can follow, so that the same amount of current must flow through each resistor, just as the amount of water flowing through a pipe is the same in each part of the pipe.

A Brief Word About Parallel Circuits

A parallel circuit is a circuit that has more than one path for current to follow, as shown by the arrows on the schematic below.

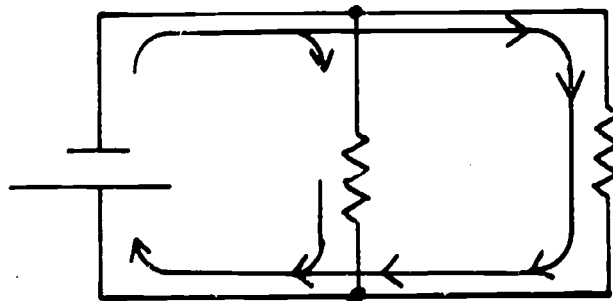

Notice in the above circuit that current from the cell divides into two separate paths; whereas, in a series circuit it can take only one path.

Using the Multimeter as an Ammeter

You are already familiar with the multimeter as an ohmmeter to measure resistance and to take continuity readings. Now you are

ready to learn how to use it as an ammeter to take current measurements. You can see that the multimeter enables you to use one meter to measure different quantities. The settings and connections when using the multimeter as an ammeter will be different than the ones used when using it as an ohmmeter.

A Word of Caution: Always connect an ammeter in series with the circuit being tested; never in parallel. Failure to do so will damage the meter.

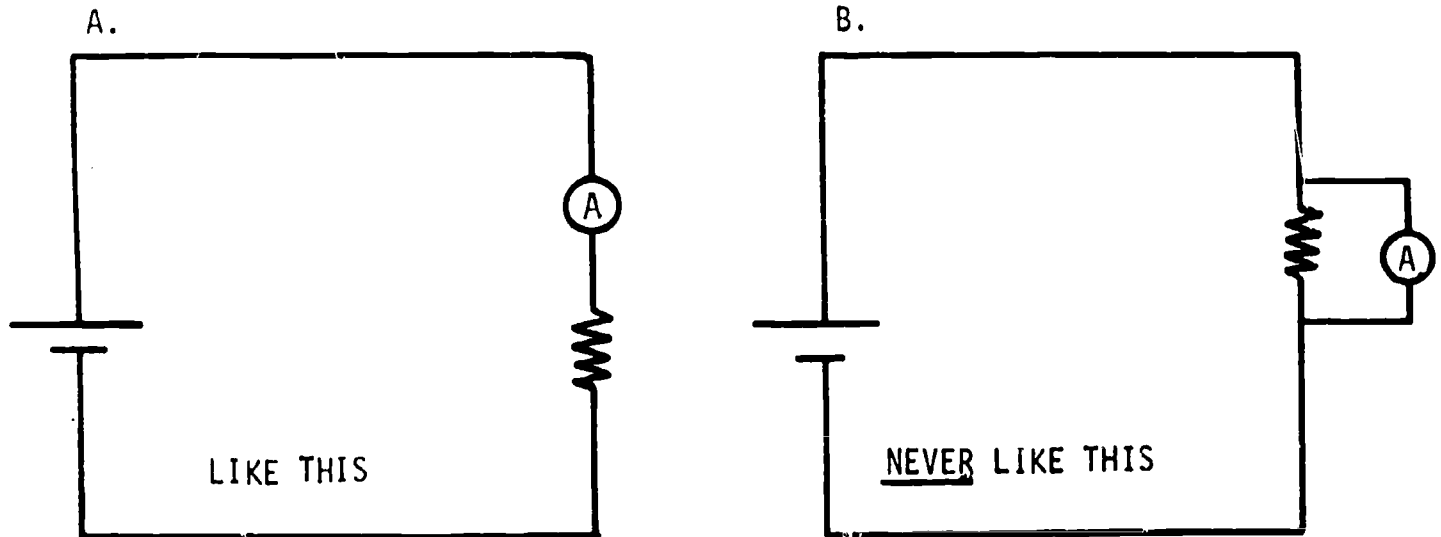

Notice in illustration A that the ammeter actually becomes part of the circuit that is being measured. Total circuit current must then flow through the meter.

Interpreting the 50 Microampere Scale (Illustration on next page)

The black arc that is labeled DC (second from top) is used for taking all DC current measurements. When the range selector switch is in the 50 microamp position, simply read the value indicated on the 0-50 scale as microamps.

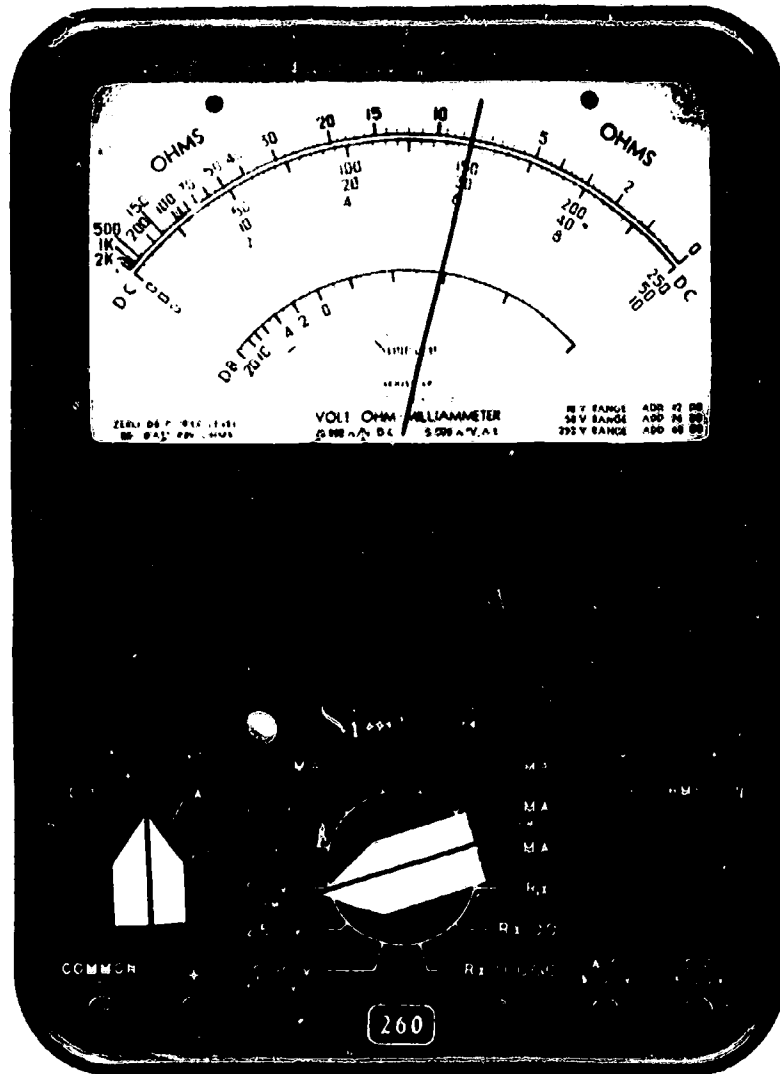

With the meter set up as indicated, what is the value of current being measured?

(30 μ a)

DC Current Measurements (0-50 μ a)

- Using Practice Board 0-1, a 51 k Ω resistor, and a dry cell, construct a series circuit as the schematic indicates.

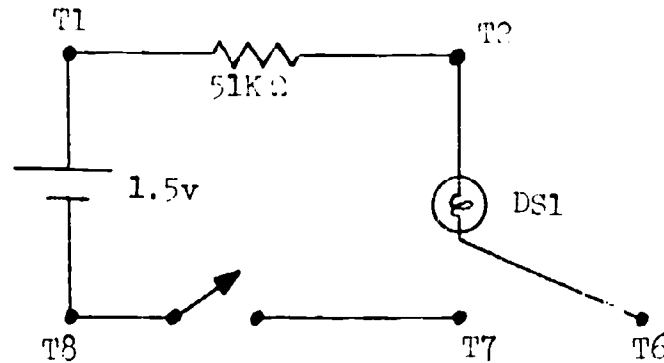

2. Be sure the switch is open.
3. Set up the multimeter as an ammeter to read 0-50 μA DC.
 - a. Set function switch at +DC.
 - b. Connect black test lead to common (-) jack.
 - c. Connect red lead to the 50 μA jack.
 - d. Attach clips to ends of test leads.
 - e. Set range switch at 50 μA . (Be sure switch is open in the circuit.)
4. Connect ammeter in series with the circuit by attaching clips to T7 and T6. Observe polarity.
5. Energize circuit. (This completes the circuit; however, the lamp will not light because the resistor limits current so much that there is not enough current to light the lamp.)
6. Record the reading obtained on the multimeter. _____
7. Open switch and disconnect meter leads.

You should have had a reading of approximately 28.5 μA .

If the needle deflected in a counter-clockwise direction, you did not observe polarity when connecting the meter. In this case, reverse the leads and try again. Your black lead must be connected to the side closest to the negative terminal of the source.

Determining Current is Common in a Series Circuit

Current through a series circuit will have the same value anywhere in the circuit. This is what we mean when we say that in a series circuit current is common. To prove this, let's measure current at another point in the circuit you constructed. You know that current is approximately 28.5 μA between T7 and T6. Now we will measure between T2 and T3.

1. Be sure circuit is de-energized.
2. Reconnect circuit as shown in the schematic, with the ammeter between T2 and T3.
3. Your meter is already set up.

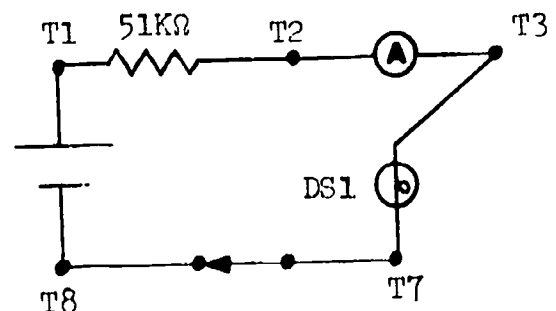

4. Energize the circuit and read the value of current. _____ Did you get the same reading you obtained at the first point of measurement? _____
5. De-energize the circuit and disconnect meter.
6. Now reconnect circuit to conform to this schematic.
7. With switch in open position, connect ammeter between T7 and T8, observing polarity. Read the value of current. _____
8. Disconnect the meter.

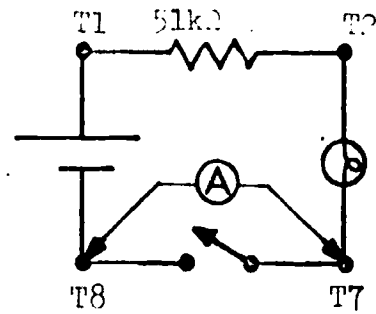

Notice that when the ammeter was connected across the open switch, the meter served to close the circuit, thus you can see that the ammeter actually becomes part of the circuit.

You have now taken current readings in three different places in the circuit and found that the readings were the same in each instance - proof that current is common in a series circuit.

BEST COPY AVAILABLE

Interpreting the 500 ma, 100 ma, 10 ma, and 1 ma Scales

For reading milliamps on the meter, we still use the same black DC arc and the three rows of numbers directly under it.

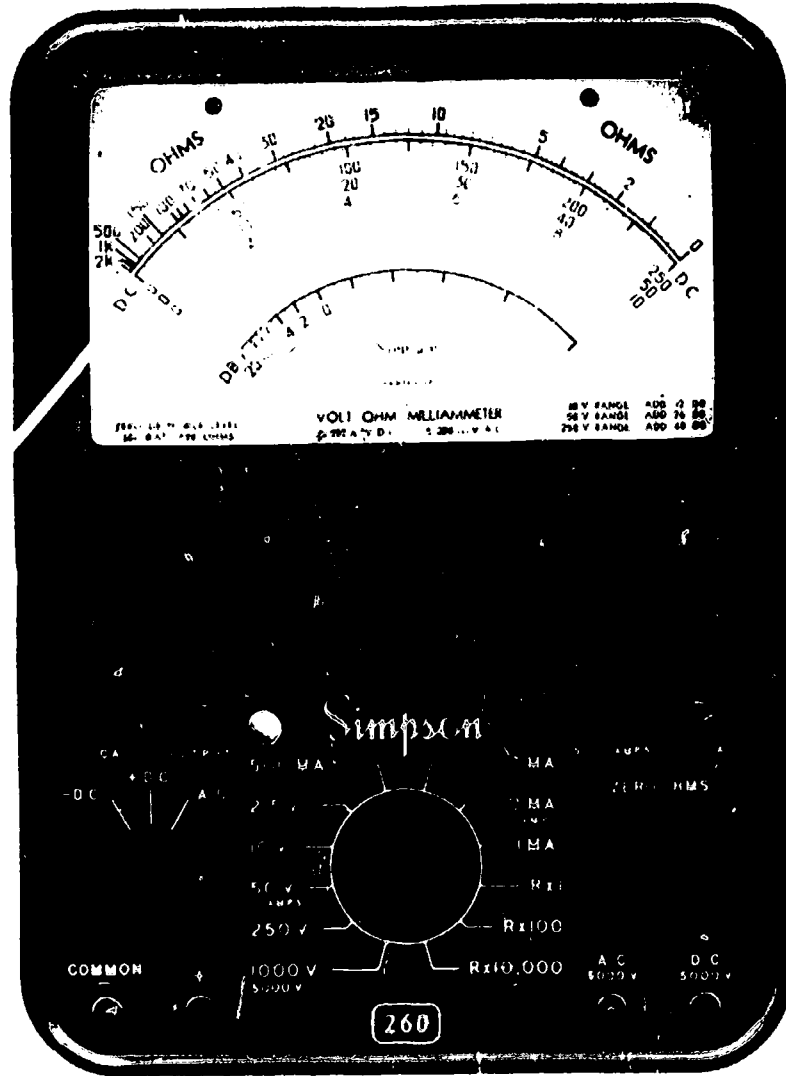

Notice the three rows of numbers under the black DC arc are calibrated 0-250, 0-50 and 0-10. If the range selector switch is on the 500ma position as shown, you simply add a zero to every number on the 0-50 scale. What you are really doing is multiplying by 10.

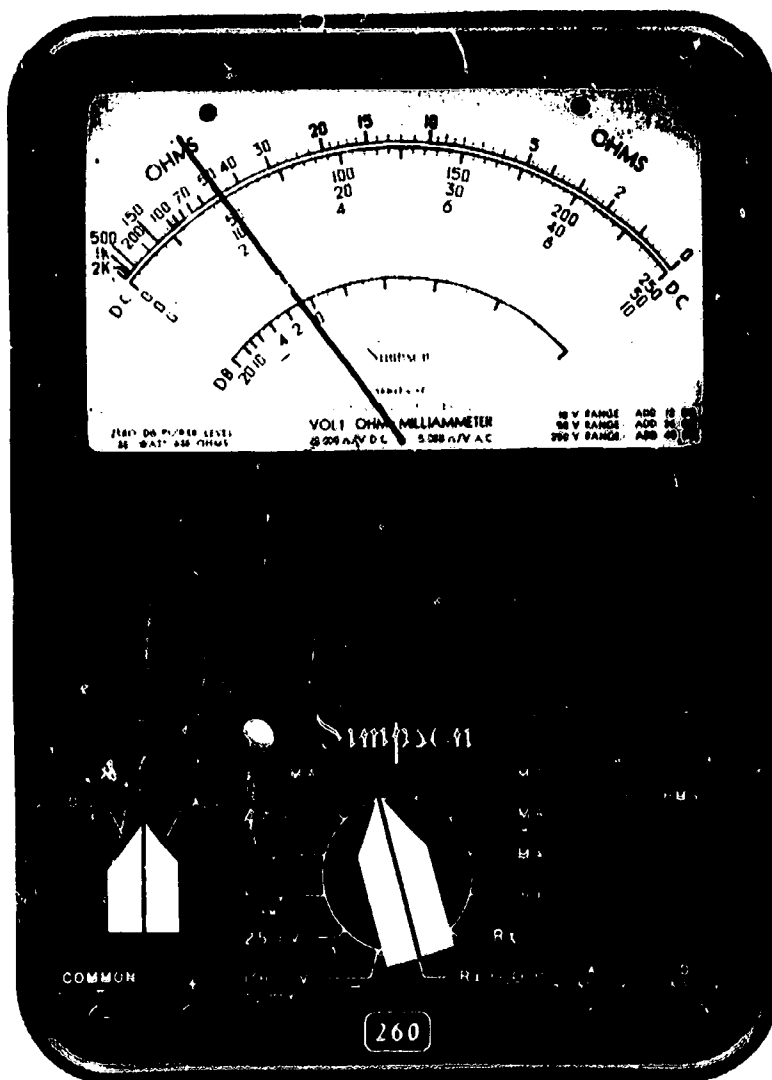

With meter set up as indicated in preceding illustration,
what is the current reading?

- a. 2 ma
- b. 2 a
- c. 10 μ a
- d. 100 ma

ANSWER - (d) 100 ma

If the range selector is on the 100 ma position, you simply add a zero to every number on the 0-10 scale. Here you are really multiplying by 10.

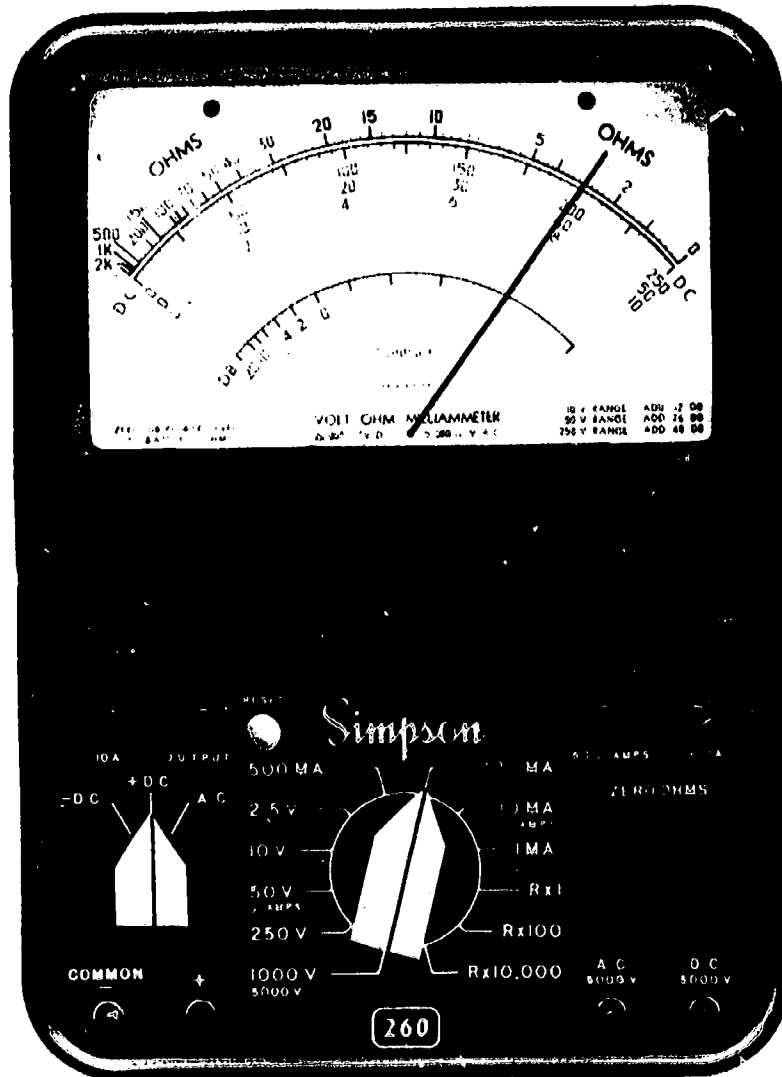

With the meter set up as indicated in the preceding illustration, what is the reading?

- a. 8 a
- b. 40 ma
- c. 80 ma
- d. 80 μ a

ANSWER - (c) 80 ma

If the range selector is set on the 10 ma position as indicated, all we do is read it directly on the 0-10 scale.

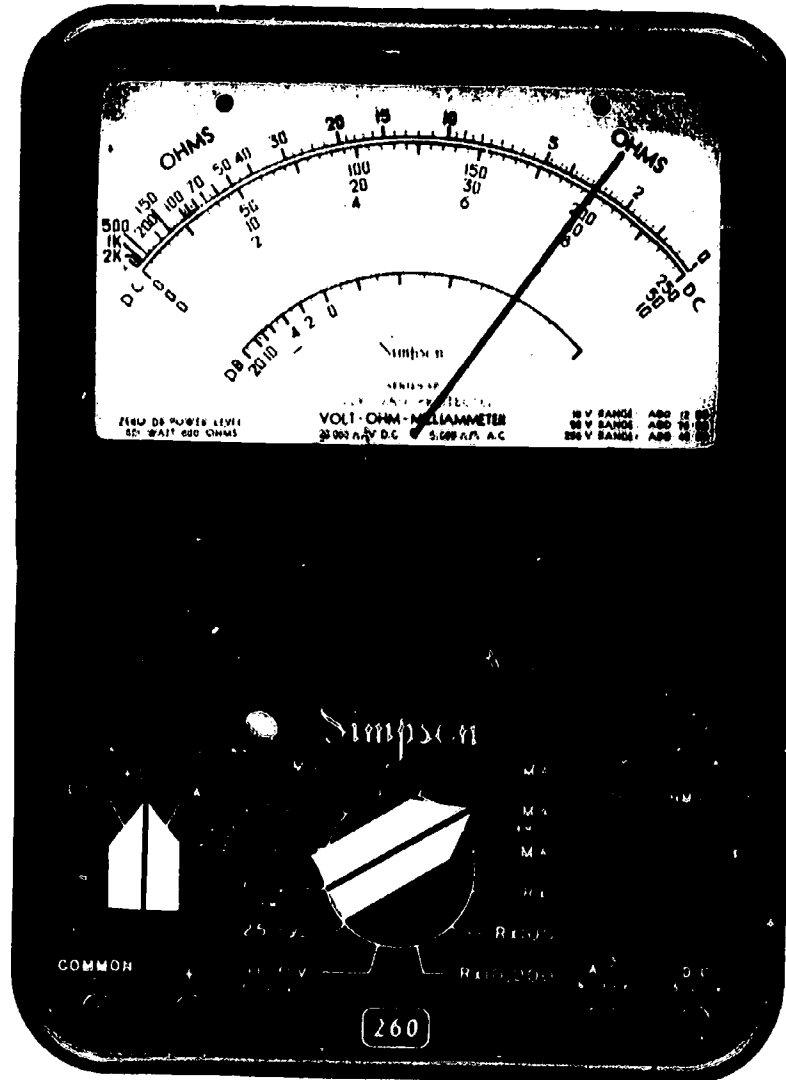

With the meter set up as indicated in the preceding illustration, what is the current reading?

- a. 40 ma
- b. 8 ma
- c. 80 ma
- d. .8 μ a

ANSWER (b) 8 ma

BEST COPY AVAILABLE

With the range selector set on the 1 ma scale as indicated, we read on the 0-10 scale and make each number a decimal .1, .2, .3, .4, .5, etc. Here you can see you are really dividing by 10.

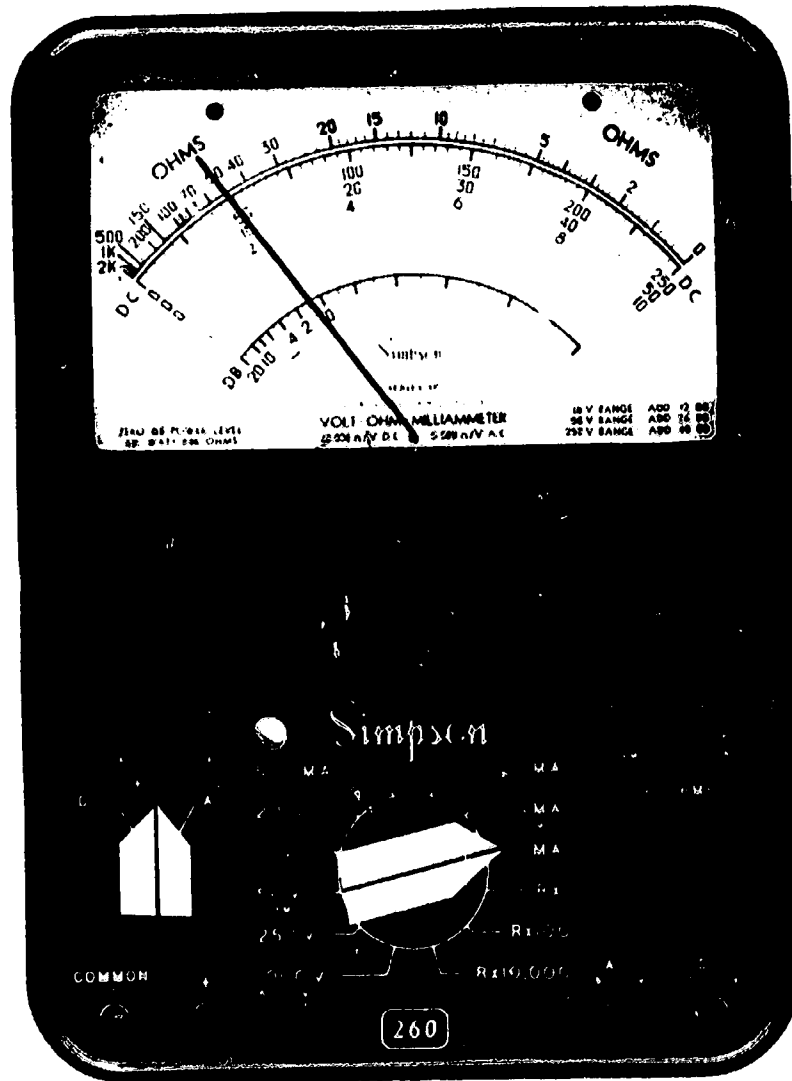

With the meter set up as indicated in the preceding illustration, what is the current reading?

- ___ a. 0.2 a
- ___ b. 0.2 ma
- ___ c. 20 ma
- ___ d. 2 μ a

ANSWER - (b) 0.2 ma

Measuring DC Current (0-500 ma)

1. Using Practice Board 10-1, a $330\ \Omega$ resistor and one dry cell, construct part of a series circuit as shown.
2. Set up the multimeter to read 0-500 ma DC.
 - a. Set function switch to +DC.
 - b. Connect black test lead in common (-) jack.
 - c. Connect red lead in the (+) jack.
 - d. Set range switch to highest ma setting (500 ma). The reason for this is that we do not know how much current will be flowing. Since current flow is still unknown, starting at the highest ma range setting can prevent damage to the meter.
 - e. Be sure switch is open.

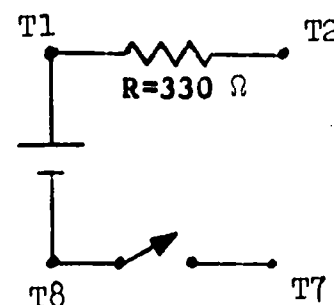

3. Connect the meter in series as shown, observing polarity.
4. Close the switch.
5. If you get no needle deflection, change the range selector to one of the other ma positions until you get as close to a mid-scale reading as possible.

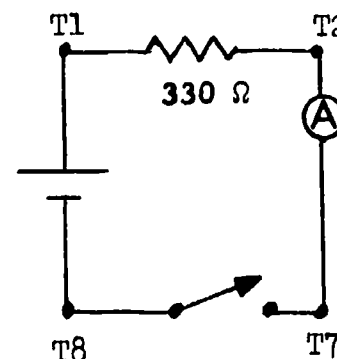

You should find that the reading is almost mid-scale at the 10 ma setting.

-
6. To read the scale for a 10 ma setting, use the black DC arc and read the 0-10 figures directly. Record current. _____
 7. De-energize the circuit and remove test leads.
-

You should have read approximately 4.4 ma.

AT THIS POINT, YOU MAY TAKE THE PROGRESS CHECK, OR YOU MAY STUDY ANY OF THE OTHER RESOURCES LISTED. IF YOU TAKE THE PROGRESS CHECK AND ANSWER ALL OF THE QUESTIONS CORRECTLY, GO TO THE NEXT LESSON. IF NOT, STUDY ANY METHOD OF INSTRUCTION YOU WISH UNTIL YOU CAN ANSWER ALL THE QUESTIONS CORRECTLY.

PROGRAMMED INSTRUCTION
LESSON 1

Measuring Current in a Series Circuit

TEST FRAMES ARE 5, 8, 12, 15, 19, 23, 33, 36, 44, 48, 59, 61, and 64. AS BEFORE, GO FIRST TO TEST FRAME 5 AND SEE IF YOU CAN ANSWER ALL THE QUESTIONS THERE. FOLLOW THE DIRECTIONS GIVEN AFTER THE TEST FRAME.

1. A series circuit is a circuit that has all its components connected end to end in a single line so that only one path for current flow exists.

Which is a schematic of a series circuit?

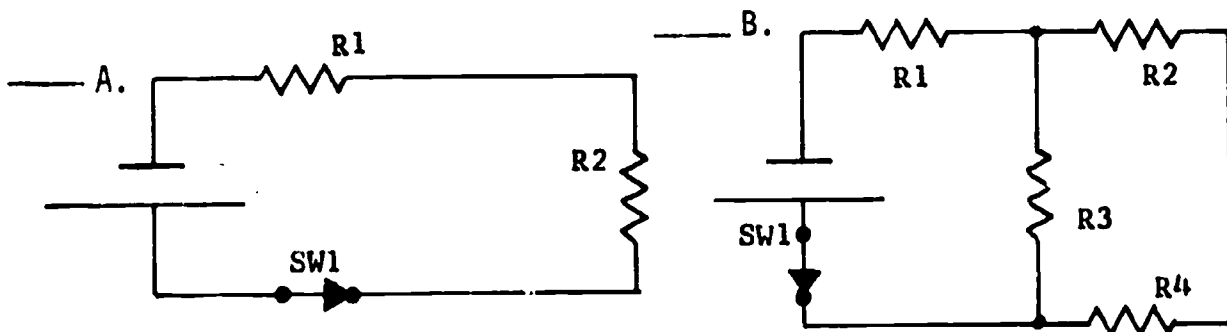

(A)

2. Recall that current flows from negative to positive in a circuit. On the series circuit schematic, indicate with arrows the path (and direction) current must follow through the circuit.

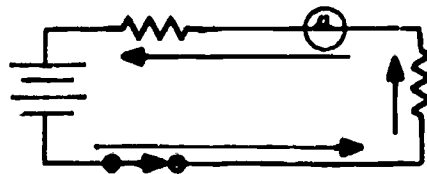
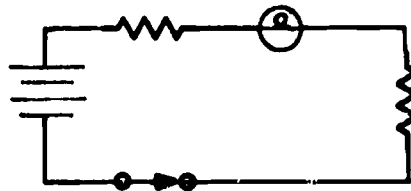

- 3. Since current in a series circuit has only one path to follow, the same amount of current will flow through each component in the circuit.

In a series circuit:

- a. current will be greater through the negative terminal of the cell than through the positive terminal.
- b. current will be the same (common) throughout the circuit.
- c. current flow will differ through each component in the circuit.
- d. the same amount of current will leave the battery as will return.

(b. current will be the same (common) throughout the circuit; and, d. the same amount of current will leave the battery as will return.)

- 4. When the same amount of current flows through each and every part of the circuit, the circuit is said to be connected in _____.

(series)

- 5. Check the correct definition of a series circuit.

- a. two or more components providing a path for current flow
- b. two or more components connected end to end to form only one path for current flow.

(THIS IS A TEST FRAME. COMPARE YOUR ANSWERS WITH THE CORRECT ANSWERS GIVEN AT THE TOP OF THE NEXT PAGE.)

ANSWERS - TEST FRAME 5

- b. two or more components connected end to end to form only one path for current flow.

IF YOUR ANSWER MATCHES THE CORRECT ANSWER, YOU MAY GO ON TO TEST FRAME 8. OTHERWISE, GO BACK TO FRAME 1 AND TAKE THE PROGRAMMED SEQUENCE BEFORE TAKING TEST FRAME 5 AGAIN.

6. Since current is common in a series circuit, the amount of current anywhere in the circuit will equal the total current drawn from the source.

What is the amount of current flow through the points indicated?

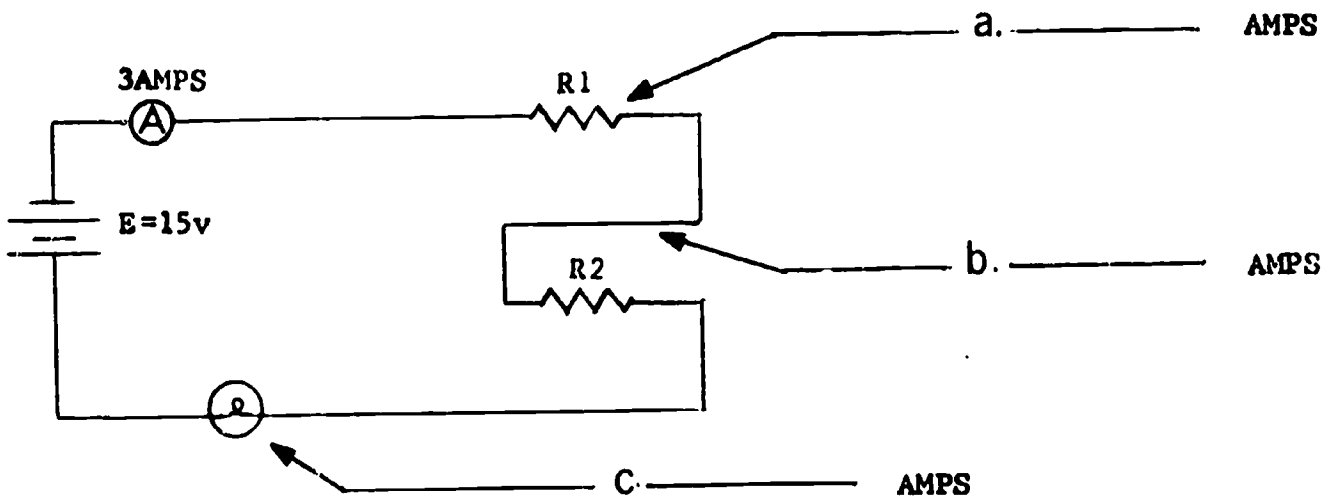

(a. 3 amps; b. 3 amps; c. 3 amps)

7. The amount of current flow anywhere in a series circuit is (equal to/different from) the total current drawn from the source.

(equal to)

8. Determine and record the indicated values of circuit current.

A.

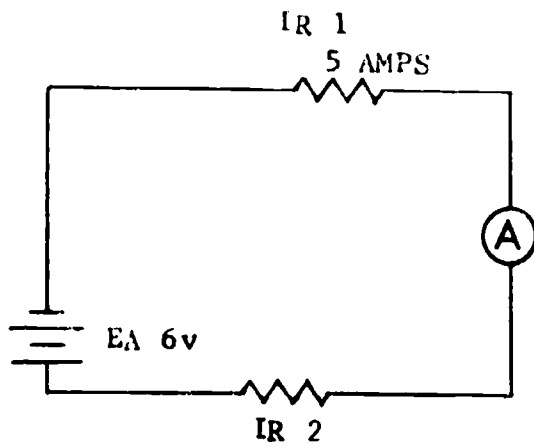

A. I_{R2} _____

B.

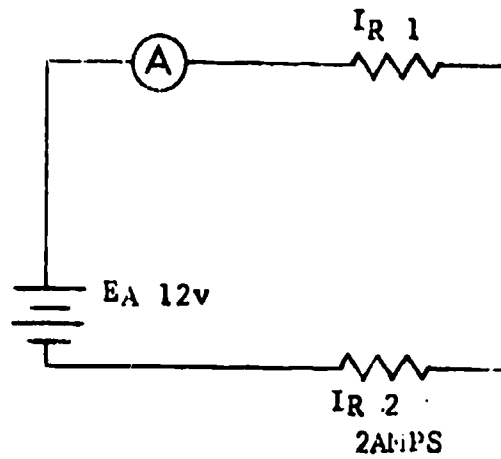

B. I_{R1} _____

(THIS IS A TEST FRAME. COMPARE YOUR ANSWERS WITH THE CORRECT ANSWERS GIVEN AT THE TOP OF THE NEXT PAGE.)

ANSWERS - TEST FRAME 8

a. =5 amps

b. =2 amps

IF ALL YOUR ANSWERS MATCH THE CORRECT ANSWERS, YOU MAY GO ON TO TEST FRAME 12. OTHERWISE, GO BACK TO FRAME 6 AND TAKE THE PROGRAMMED SEQUENCE BEFORE TAKING TEST FRAME 8 AGAIN.

9. A parallel circuit differs from a series circuit in that it has two or more paths for current flow. Two examples of parallel circuits are shown below.

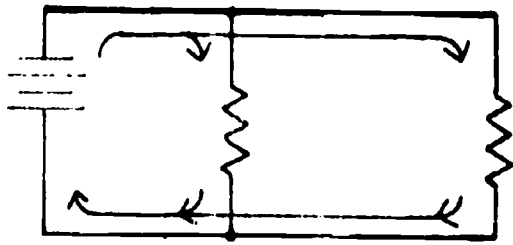

2 PATHS

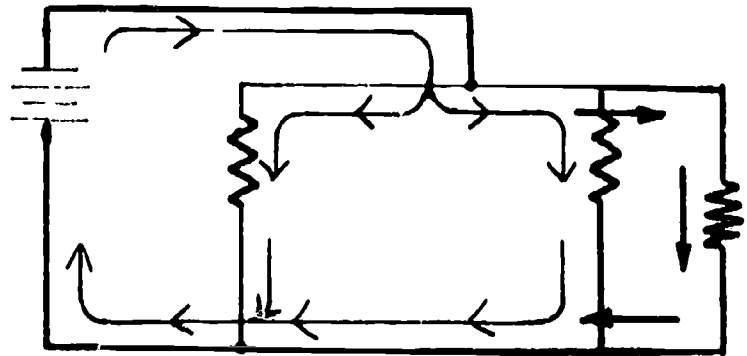

3 PATHS

Indicate with arrows the current paths in the parallel circuits. In the spaces below each circuit, write the number of paths that exist for current flow.

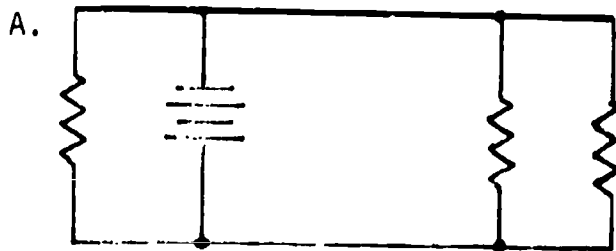

NUMBER OF PATHS _____

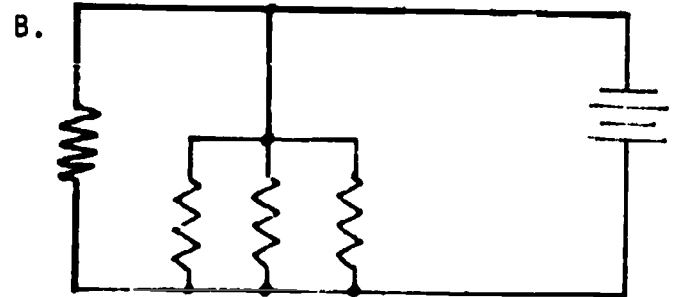

NUMBER OF PATHS _____

(a. 3; b. 4)

A.

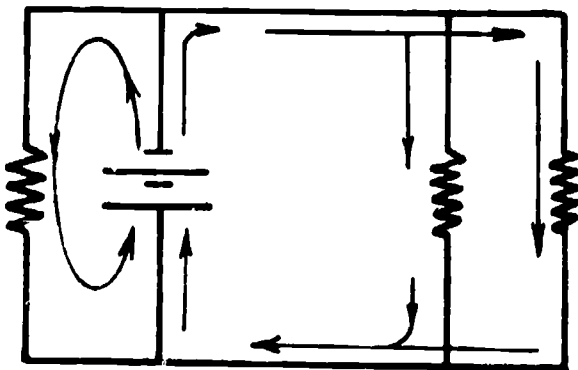

B.

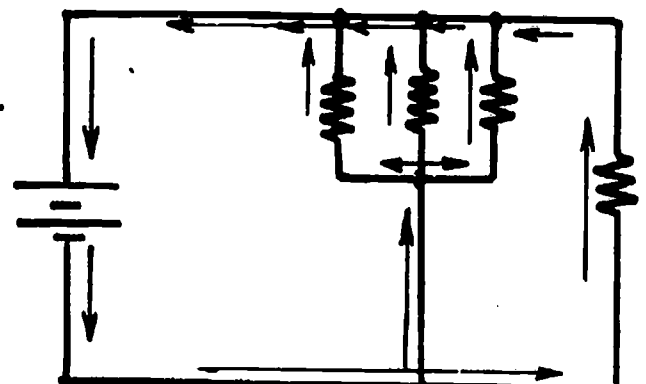

10. Each path for current flow is called a branch. How many branches are there in the circuit below? _____

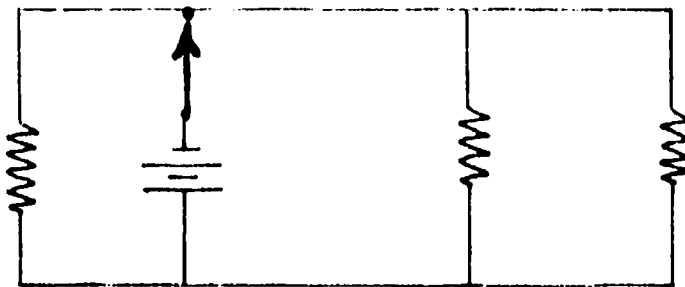

(3 branches)

11. Match the kind of circuit to its correct definition.

- | | |
|---|---------------------|
| _____ 1. circuit that has two or more paths for current flow | a. parallel circuit |
| _____ 2. circuit that has two or more components connected end to end to form only one path for current flow. | b. series circuit |

(1. a; 2. b)

12. Match the schematics to their appropriate characteristics.

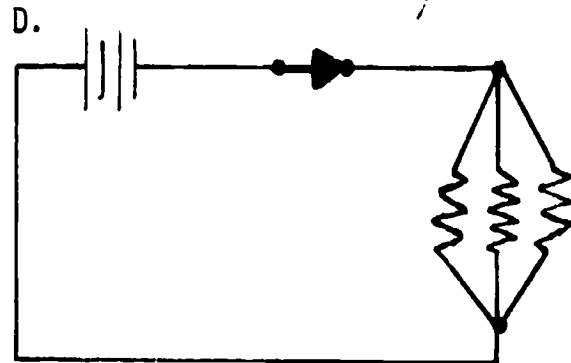
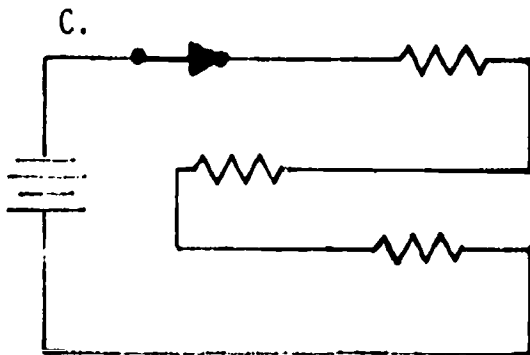
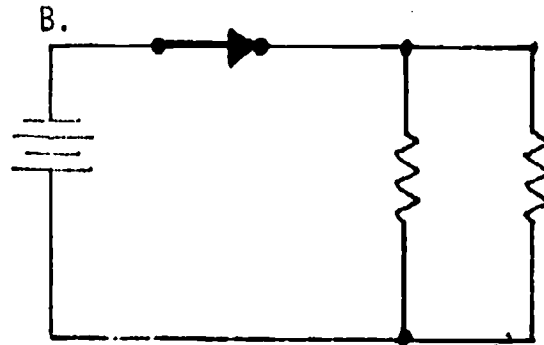
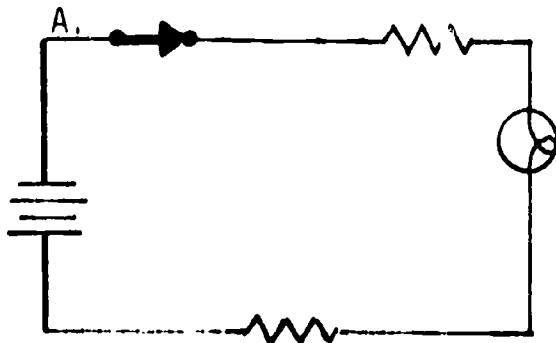

- ___ 1. more than one path for current flow
- ___ 2. series circuit
- ___ 3. parallel circuit
- ___ 4. only one path for current flow
-

(THIS IS A TEST FRAME. COMPARE YOUR ANSWERS WITH THE CORRECT ANSWERS GIVEN AT THE TOP OF THE NEXT PAGE.)

ANSWERS - TEST FRAME 12

1. B, D
2. A, C
3. B, D
4. A, C

IF ALL YOUR ANSWERS MATCH THE CORRECT ANSWERS, YOU MAY GO ON TO TEST FRAME 15. OTHERWISE, GO BACK TO FRAME 9 AND TAKE THE PROGRAMMED SEQUENCE BEFORE TAKING TEST FRAME 12 AGAIN.

13. When using the multimeter as an ammeter for measuring DC current, it must always be connected in series with the load. Remember -- in series means in a line.

Which schematic shows the multimeter correctly installed as an ammeter?

A.

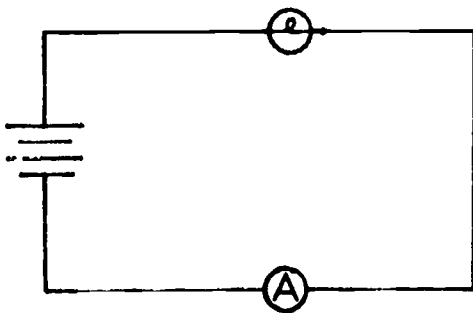

B.

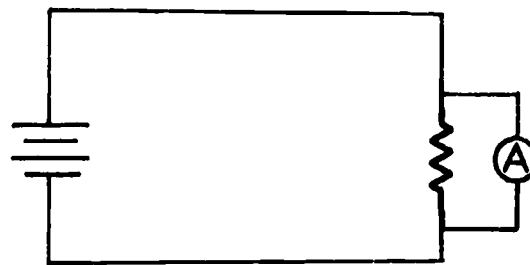

(A)

14. To connect an ammeter (multimeter) properly in a circuit, polarity must be observed. The negative side of the meter must be connected to the negative side of the source, and the positive side of the meter to the positive side of the source.

Which schematic shows the multimeter correctly installed as an ammeter?

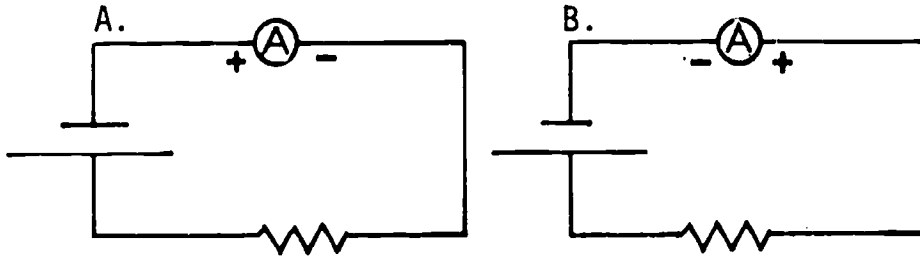

(B)

15. Check the schematic that shows the meter correctly installed.

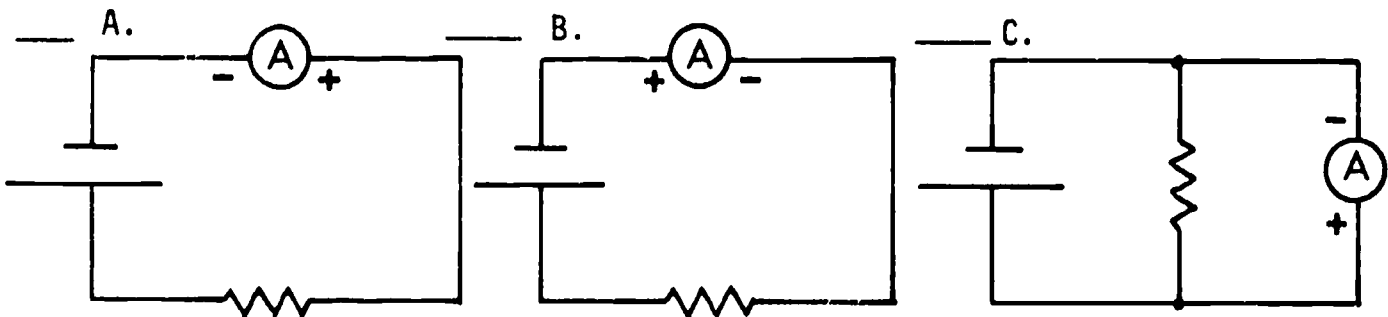

(THIS IS A TEST FRAME. COMPARE YOUR ANSWERS WITH THE CORRECT ANSWERS GIVEN AT THE TOP OF THE NEXT PAGE.)

ANSWER - TEST FRAME 15

A

IF YOUR ANSWER MATCHES THE CORRECT ANSWER, YOU MAY GO ON TO TEST FRAME 19. OTHERWISE, GO BACK TO FRAME 13 AND TAKE THE PROGRAMMED SEQUENCE BEFORE TAKING TEST FRAME 15 AGAIN.

16. The illustration below shows the front panel and controls associated with the ammeter function of the Simpson 260-5P multimeter. Study the illustration, then locate these components and controls on your multimeter.

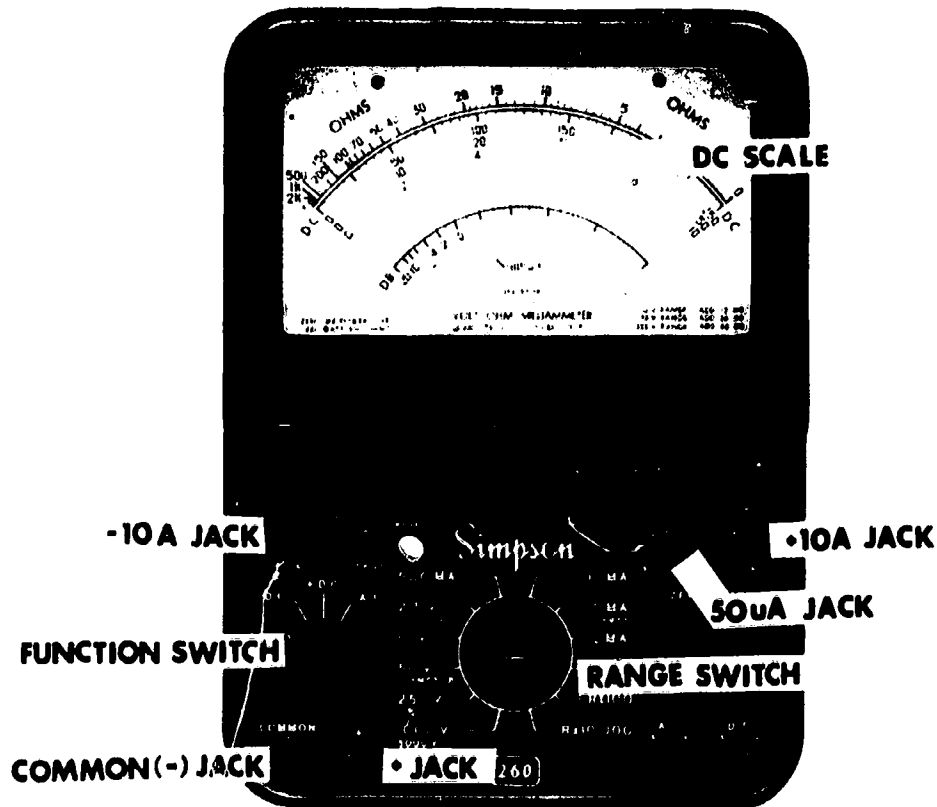

(Go to next frame.)

17. Locate the function switch on your multimeter.

What are the three positions to which the function switch can be moved? (Any order)

a. _____

b. _____

c. _____



(-DC; +DC; AC)

18. The position of the function switch determines whether the multimeter is to be used to measure AC or DC values. When used as an ammeter for measuring direct current, the function switch can be in either of the DC positions. (Except for use in the 50 μ a or 10 amp range. These ranges require +DC setting.)

What function switch setting(s) could be used when measuring direct current?

_____ a.

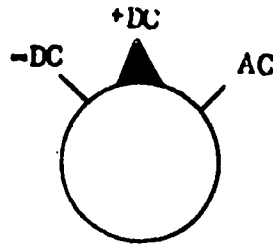

_____ b.

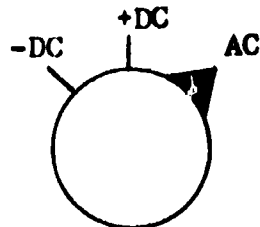

_____ c.

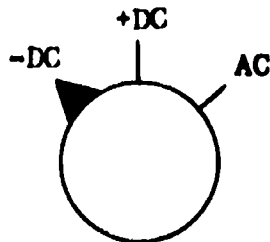

(a; c)

19. To measure direct current, the function switch must be in the _____ or the _____ positions. (Any order)

(THIS IS A TEST FRAME. COMPARE YOUR ANSWERS WITH THE CORRECT ANSWERS GIVEN AT THE TOP OF THE NEXT PAGE.)

ANSWERS - TEST FRAME 19

+DC; -DC

(Remember: When using the 50 μ a or 10 amp range, the switch must be in the +DC position.)

IF ALL YOUR ANSWERS MATCH THE CORRECT ANSWERS, YOU MAY GO ON TO TEST FRAME 23. OTHERWISE, GO BACK TO FRAME 16 AND TAKE THE PROGRAMMED SEQUENCE BEFORE TAKING TEST FRAME 19 AGAIN.

20. When setting up the multimeter to measure current, the function switch is normally placed in the +DC position. Remember, the multimeter is polarity sensitive and must be connected in the proper manner (black lead negative, red lead positive) in the circuit to prevent damage to the meter.

Which drawing shows the multimeter correctly connected for measuring current?

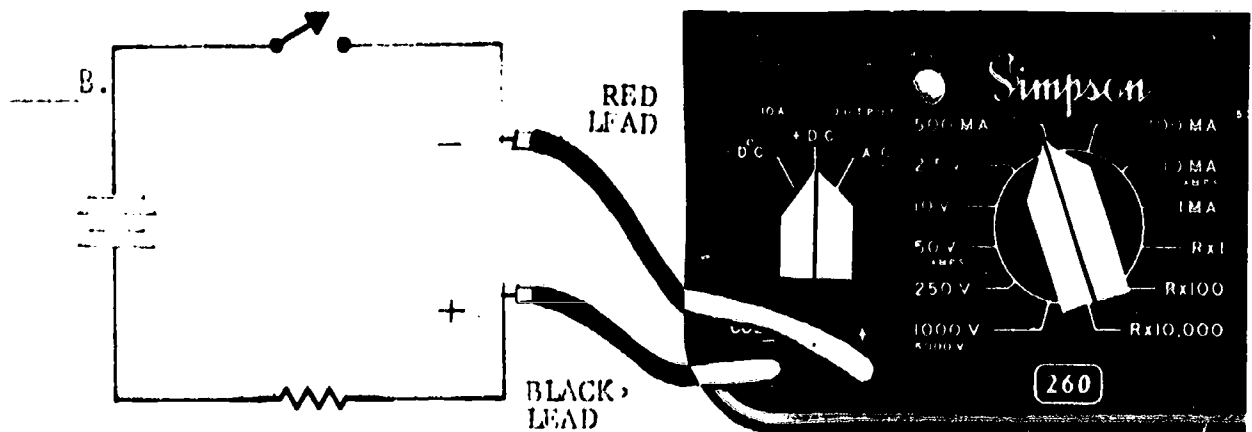
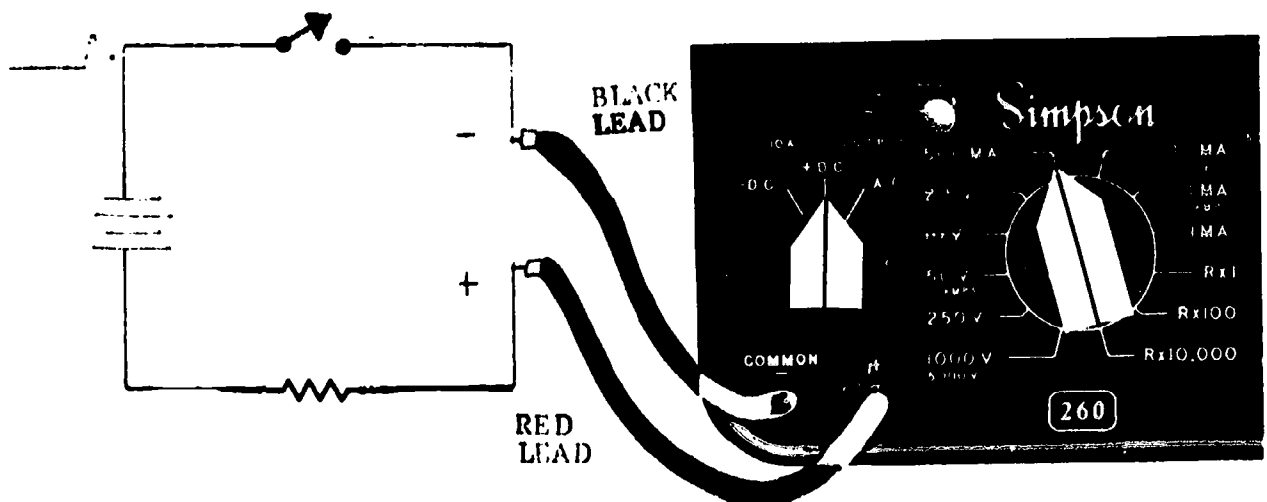

(A)

21. If for some reason the meter is connected improperly, the function switch can be used to change the polarity of the meter without removing the meter leads from the circuit under test. (This does not apply to the 50 μ a or the 10 amp range.)

The illustration below shows an improper meter connection.

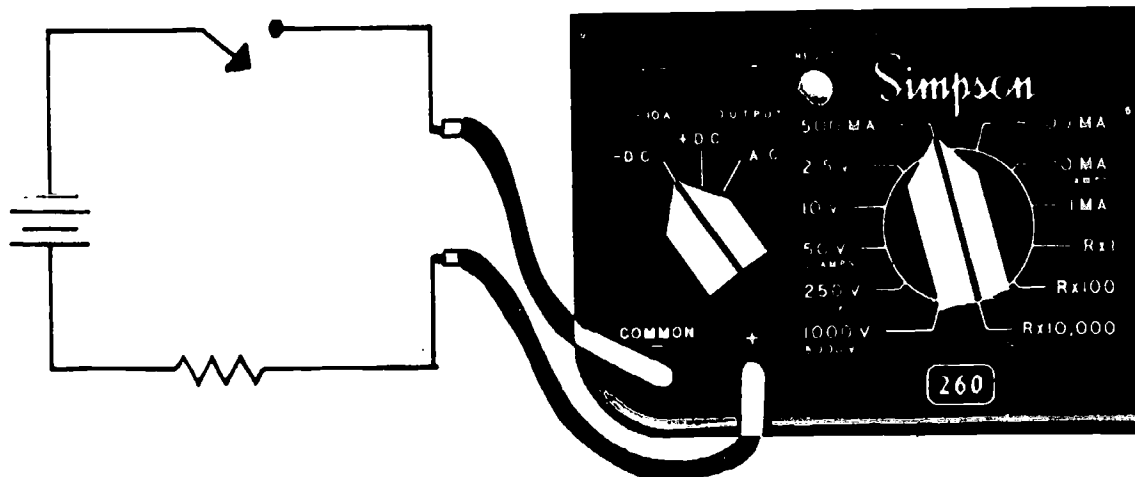

Check the function-switch position you would use to correct the meter connection shown above.

- a.
- b.
- c.

(a)

22. Since the pointer of the meter normally rests at "0" on the far left of the meter scale, correct connection into a circuit will cause the pointer to move toward the right side.

Which of the meter faces below indicate correct meter connection and function switch setting?

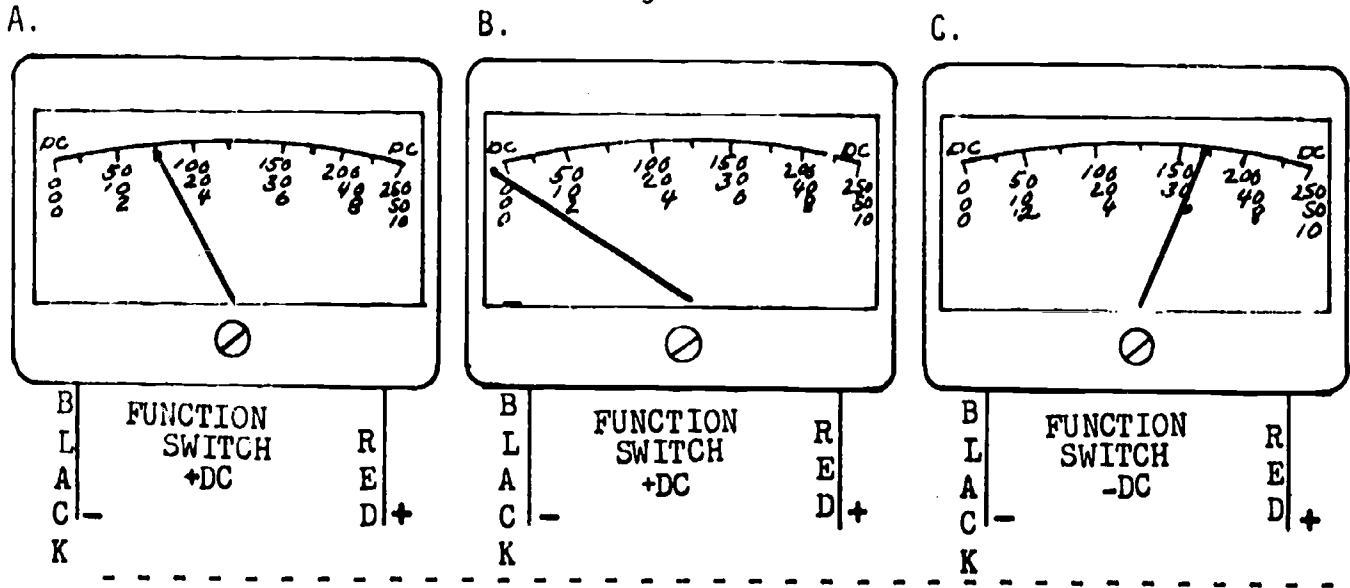

(A; C)

23. Which meter is correctly connected for measuring DC current?

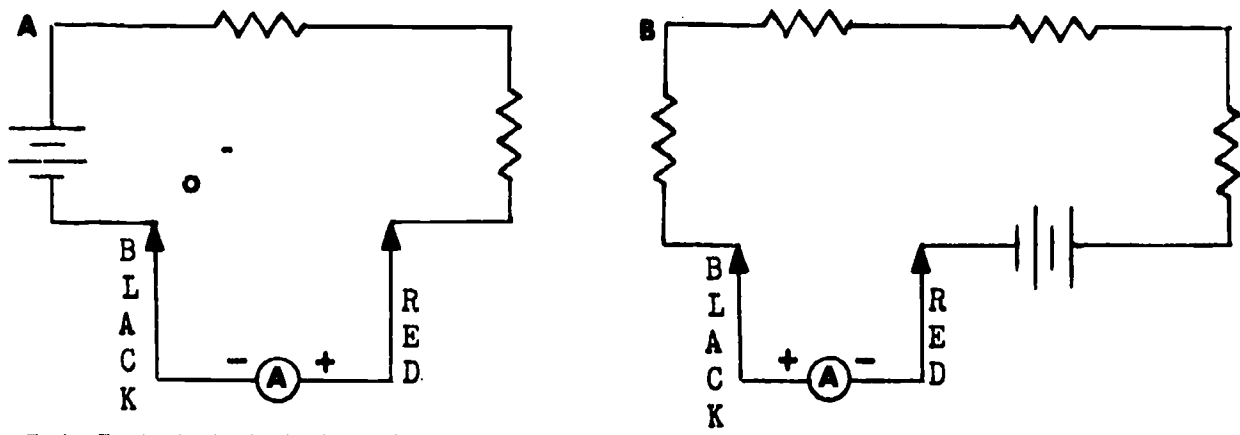

(THIS IS A TEST FRAME. COMPARE YOUR ANSWERS WITH THE CORRECT ANSWERS GIVEN AT THE TOP OF THE NEXT PAGE.)

ANSWERS - TEST FRAME 23

A

IF ALL YOUR ANSWERS MATCH THE CORRECT ANSWERS, YOU MAY GO ON TO TEST FRAME 33. OTHERWISE, GO BACK TO FRAME 20 AND TAKE THE PROGRAMMED SEQUENCE BEFORE TAKING TEST FRAME 23 AGAIN.

24. Locate the range switch on your multimeter. The range switch also determines how the meter will be used. For example, when used as an ohmmeter for measuring resistance, the following range settings are used:

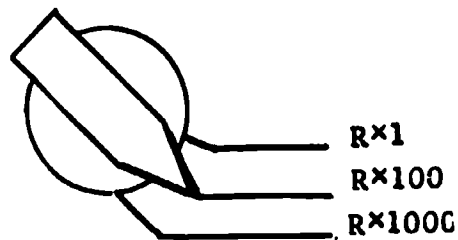

Refer to your Simpson 260-5P multimeter. Which drawing shows the range switch settings that would be used to measure direct current?

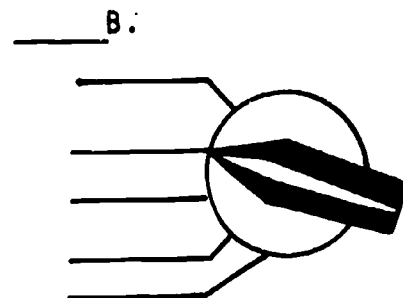
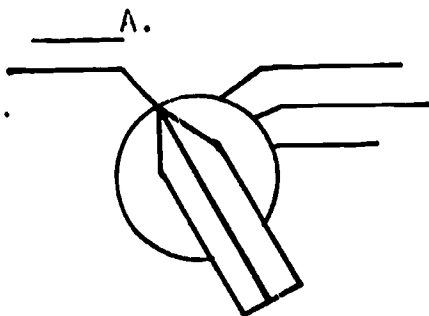

(A)

25. Look at the range-switch positions on your multimeter. The maximum DC current measurement possible with the Simpson 260-5P multimeter is:

- ___ a. 500 ma DC.
 ___ b. 10 amps DC.
 ___ c. 100 amps DC.
 ___ d. 50 μ a DC.

(b)

26. List the five positions of the range switch that are used to measure D. . current. (Any order)

 (50 μ a; 500 ma; 100 ma; 10 ma/10 amps; 1 ma)

27. Each current range-switch setting represents the maximum amp-erage that the multimeter is capable of measuring when in that position. For example, if the range switch is set at 50 μ a, this means that the current range is 0-50 μ a; if the range switch is set at 10 ma, the current range would be 0-10 ma.

What would the current range be if the range switch was set at 500 ma?

- _____ a. 100-500 ma
 _____ b. 0-500 ma
 _____ c. 10-500 ma

 (b) 0-500 ma

28. Look at the current range switch positions again. Then list the current ranges the meter is designed to measure. (Any order)

 (0-50 μ a; 0-1 ma; 0-10 ma/amps; 0-100 ma; 0-500 ma)

29. The meter scale used when measuring current is the black arc that is labeled DC (second from top). Locate the DC scale on your multimeter, then check the arrow that points to the DC scale.

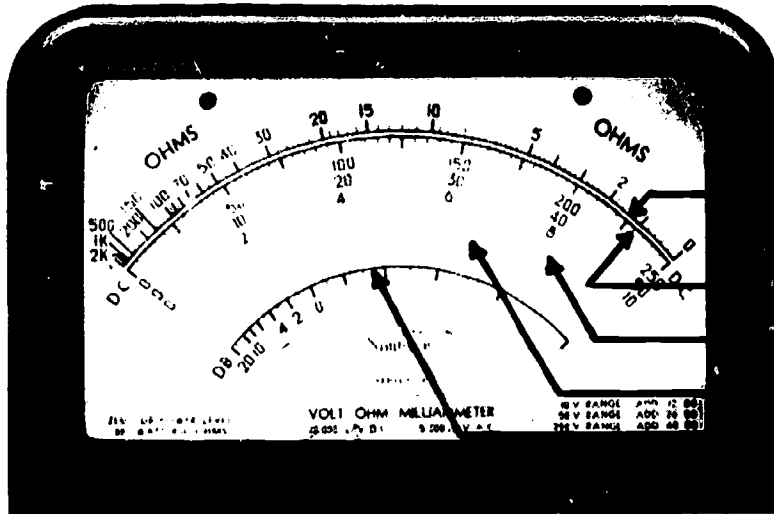

(B)

30. Look at the DC scale on your multimeter again. Notice that there are three rows of numbers under the black DC arc, marked 0-250, 0-50, and 0-10. The meter scales used for DC current measurements are the 0-50 and 0-10 scales.

Which diagram correctly identifies the two DC scales used for measuring DC current?

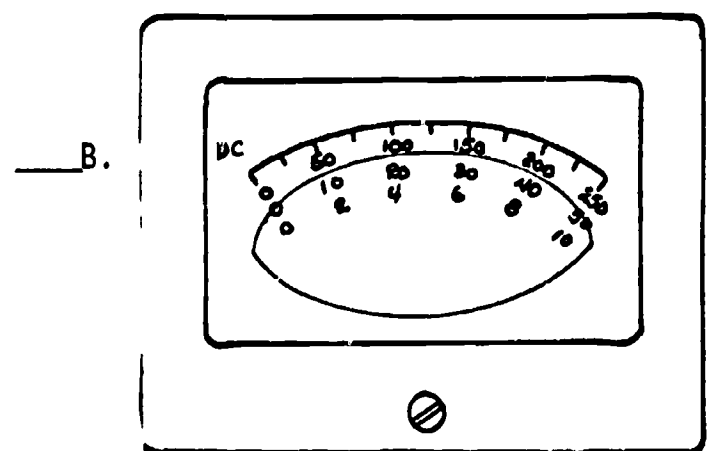
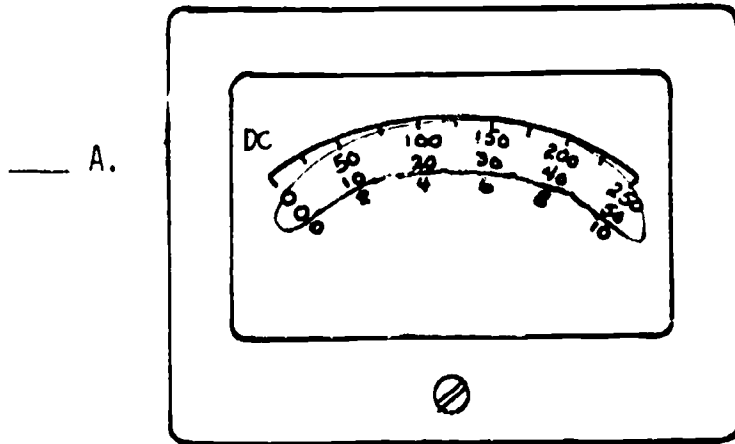

(B)

31. The position of the range switch (50 μ a, 500 ma, 100 ma, 10 ma/amps, 1 ma) will determine whether the 0-10 DC scale or the 0-50 DC scale is used. When the range switch is in the 50 μ a position, the 0-50 scale is used.

Which meter scale is used to read 0-50 μ a DC?

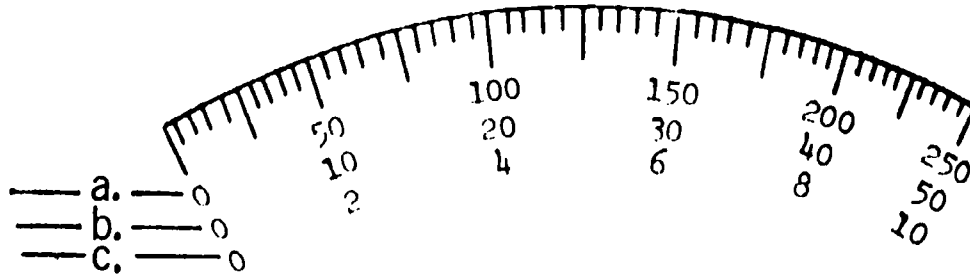

(b)

32. When the range switch is in the 50 μ a position, current is read directly on the 0-50 scale.

What would the current reading be for the illustration?

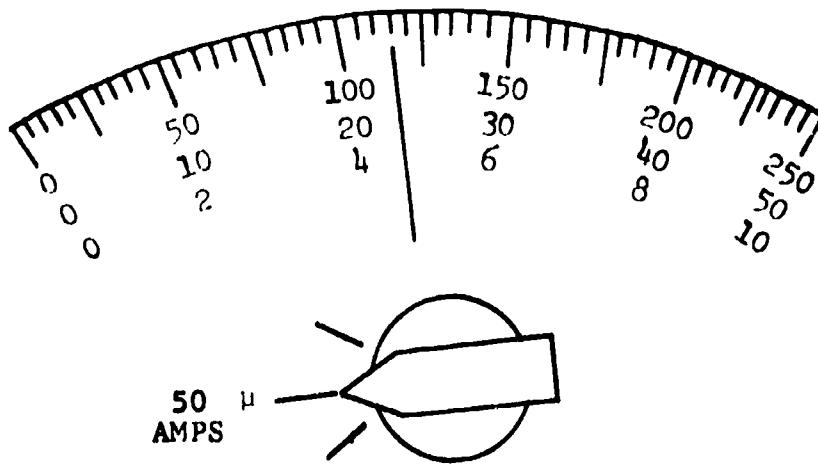

- a. 103 microamps
 b. 23 microamps
 c. 7 microamps

(b) 23 microamps

33. Which illustration indicates a current value of $10 \mu\text{a}$?

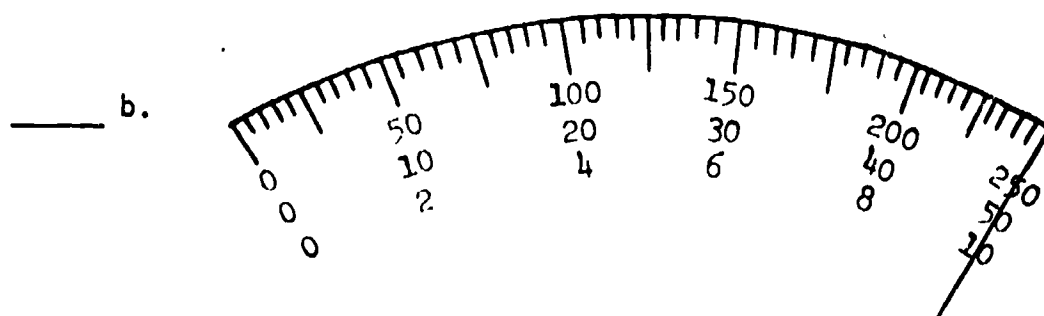
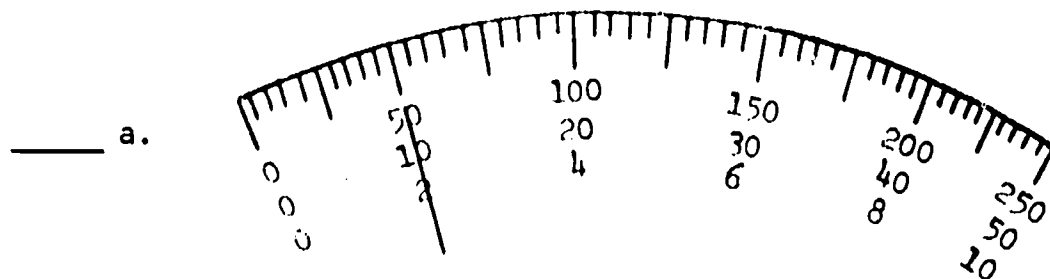

(THIS IS A TEST FRAME. COMPARE YOUR ANSWER WITH THE CORRECT ANSWER GIVEN AT THE TOP OF THE NEXT PAGE.)

ANSWER - TEST FRAME 33

a

IF YOUR ANSWER MATCHES THE CORRECT ANSWER, YOU MAY GO ON TO TEST FRAME 36. OTHERWISE, GO BACK TO FRAME 24 AND TAKE THE PROGRAMMED SEQUENCE BEFORE TAKING TEST FRAME 33 AGAIN.

34. When using the multimeter to read 0-50 μ a DC, the common (-) jack and the 50 μ a jack are used.

Using the illustration below, locate on your multimeter the common (-) jack and the 50 μ a jack.

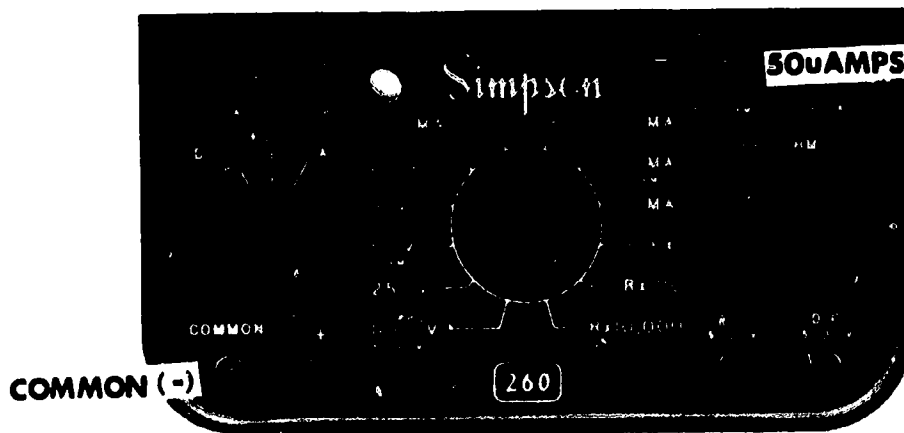

(Go to next frame)

35. On the illustration below, check the arrows which point to the jacks used when making current measurements in the range 0-50 μ a.

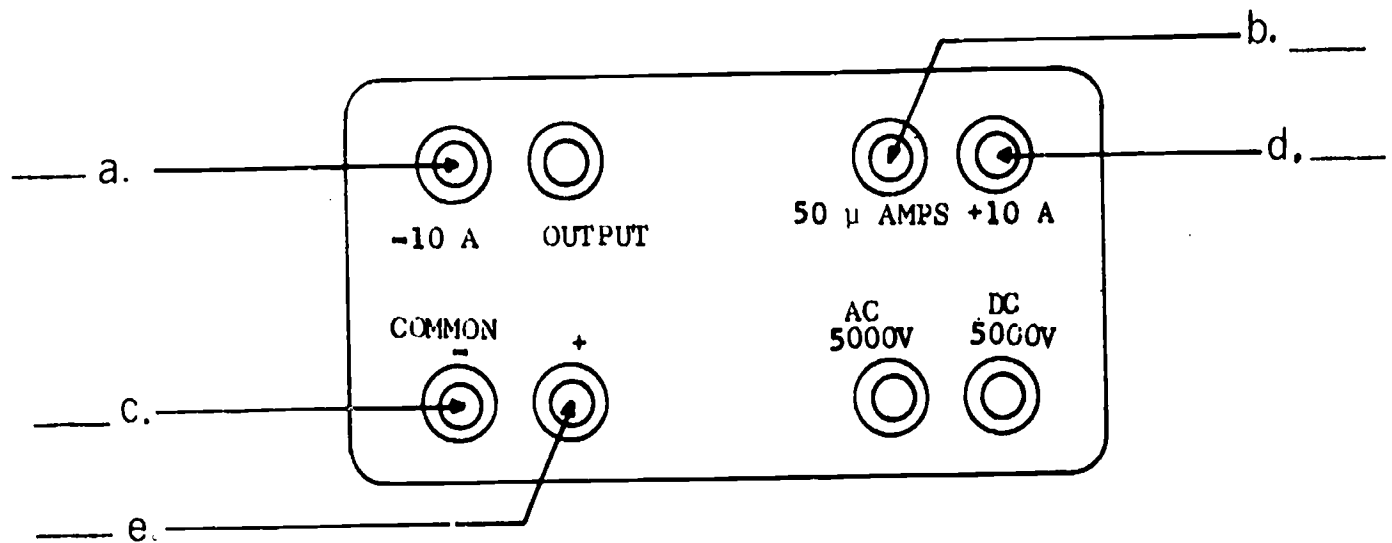

36. List the names of the two jack positions used when making DC current measurements in the 0-50 μ a range. (Any order)

a. _____

b. _____

(THIS IS A TEST FRAME. COMPARE YOUR ANSWERS WITH THE CORRECT ANSWERS GIVEN AT THE TOP OF THE NEXT PAGE.)

ANSWERS - TEST FRAME 36

- a. 50 μ a jack
 b. common (-) test jack
-

IF ALL YOUR ANSWERS MATCH THE CORRECT ANSWERS, YOU MAY GO ON TO TEST FRAME 44. OTHERWISE, GO BACK TO FRAME 34 AND TAKE THE PROGRAMMED SEQUENCE BEFORE TAKING TEST FRAME 36 AGAIN.

37. Using Practice Board 0-1, a 51 k Ω resistor, and one dry cell, construct a series circuit as shown below.

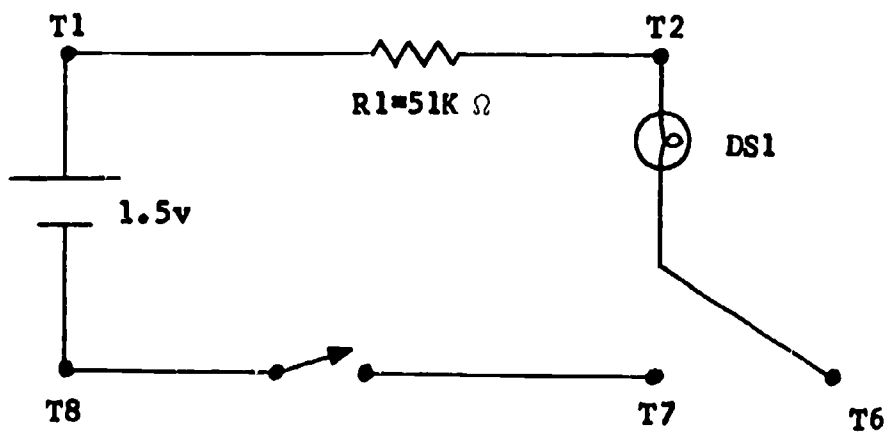

Make sure the switch is open.

(Go to next frame)

38. Listed below are the proper steps for setting up the multimeter for measuring DC current in the 0-50 μ a range.

1. Set the function switch at +DC.
2. Connect the black test lead in the common (-) jack and the red test lead in the 50 μ a jack. (Use test leads with clips.)
3. Set the range switch at 50 μ a.

Following the steps listed above, set up your multimeter, then check your meter setup against this illustration.

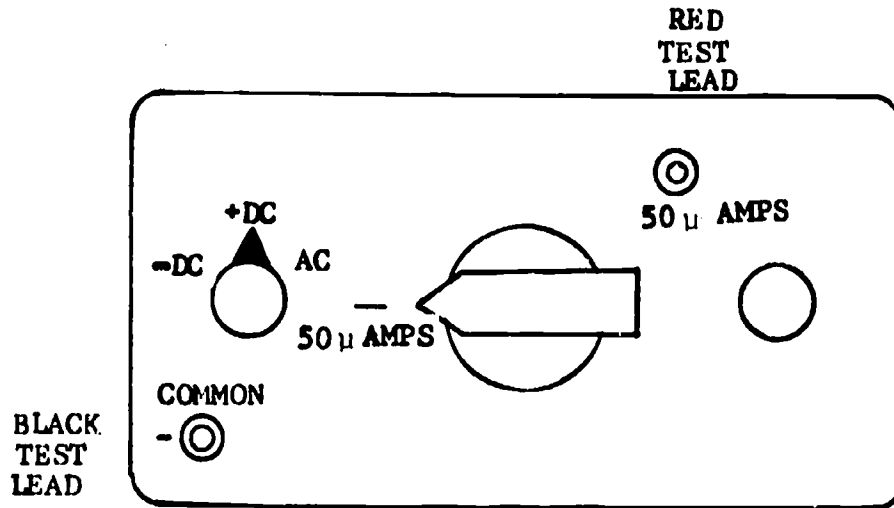

(Go to next frame)

39. Take the series circuit you have constructed and connect the meter in series with the load (between T6 and T7), connecting the red test lead toward the positive side of the source and the black test lead toward the negative side. **MAKE SURE THE SWITCH IS _____ BEFORE CONNECTING THE METER.**

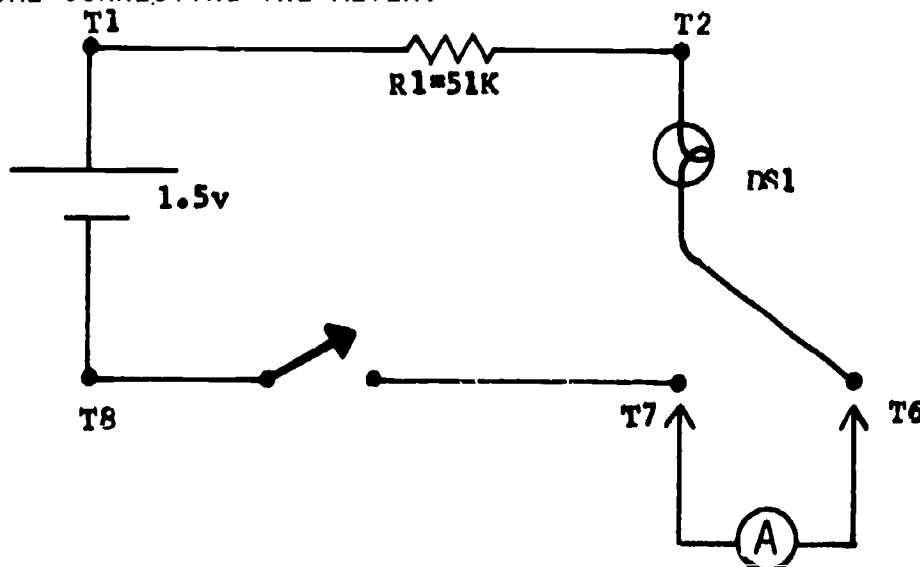

(open)

40. Energize circuit and observe the meter pointer. If it is deflected to the left, the polarity is opposite to that which was anticipated. De-energize the circuit, reverse the meter leads, and energize circuit again. (Note: Meter polarity cannot be reversed by using the function switch except when measuring milliamps.)

(Go to the next frame.)

41. Read the current directly on the black DC arc using the 0-50 scale. What is the amount of current flowing in the circuit?

(approximately 28.5 μ a)

42. De-energize the circuit and remove the test leads from the circuit. Restore the circuit to its normal working condition.

(Go to next frame)

43. Recall that current is the same throughout a series circuit. Modify the series circuit you have constructed as indicated by the schematic.

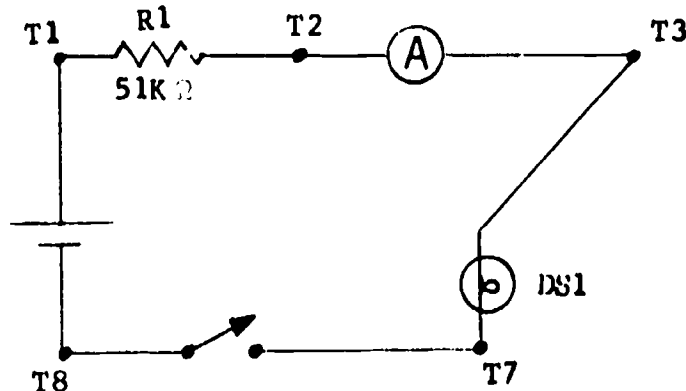

Then measure current and record it in the space provided.
 Circuit current = _____ μ a.

Do you read the same value of current as when the meter was connected between T6 and T7?

(approximately 28.5 μ a; yes)

44. Using Practice Board 0-1, a $62\text{ k}\Omega$ resistor, and one dry cell, construct a series circuit as shown below.

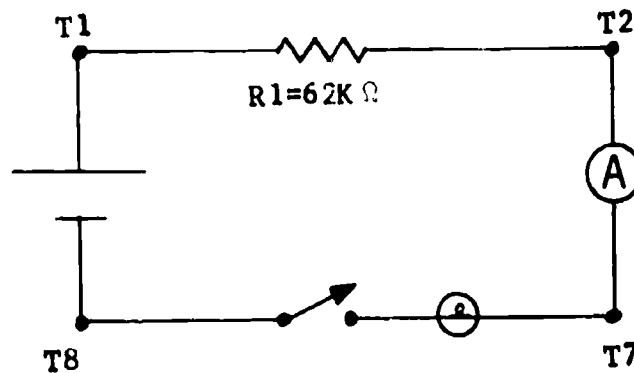

Then measure current and record it in the space provided.

Circuit current = _____.

(THIS IS A TEST FRAME. COMPARE YOUR ANSWER WITH THE CORRECT ANSWER GIVEN AT THE TOP OF THE NEXT PAGE.)

ANSWER - TEST FRAME 44

23-26 μ a

(Note: The lamp will not light because the resistor, in this instance, greatly limits the current flow.)

IF YOUR ANSWER MATCHES THE CORRECT ANSWER, YOU MAY GO ON TO TEST FRAME 48. OTHERWISE, GO BACK TO FRAME 37 AND TAKE THE PROGRAMMED SEQUENCE BEFORE TAKING TEST FRAME 44 AGAIN.

45. Complete the following chart for using the Simpson 260-5P multi-meter as an ammeter.

CURRENT RANGE	FUNCTION SW. POSITION	RANGE SW. POSITION	METER DC SCALE	TEST LEADS POSITION	
				RED	BLACK
0-50 μ a					

CURRENT RANGE	FUNCTION SW. POSITION	RANGE SW. POSITION	METER DC SCALE	TEST LEADS POSITION	
				RED	BLACK
0-50 μ a	+ DC	50 μ a	0-50	50 μ a	(-) common

46. When reading current below 500 ma, the DC scale used will depend on the position of the range switch. When the range switch is in the 500 ma position, current is read on the 0-50 scale.

Which meter scale is used when the range switch position is 500 ma?

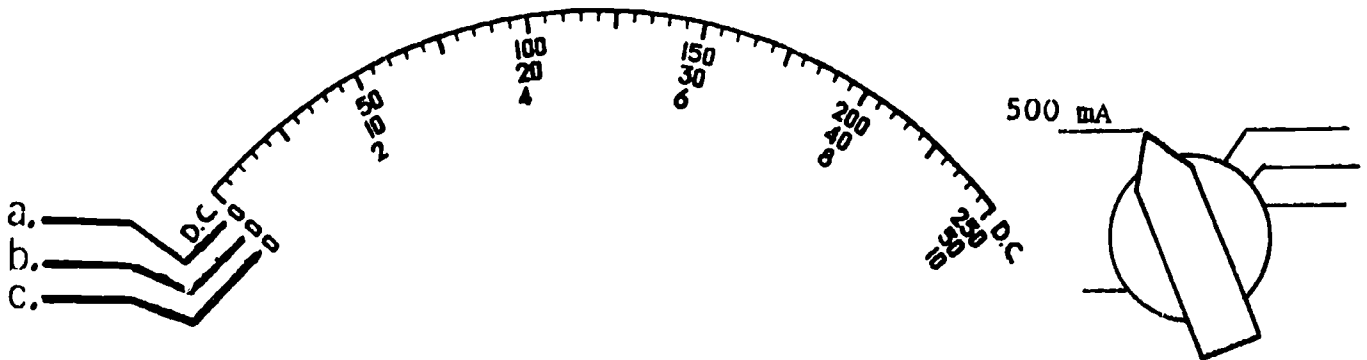

(b)

47. If the range switch is in the 500 ma position, the value indicated on the 0-50 scale must be multiplied by 10 to obtain the amount of current. For example, with the meter set up as shown below, the current flow would be 200 ma.

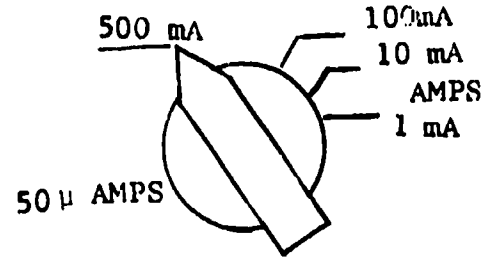
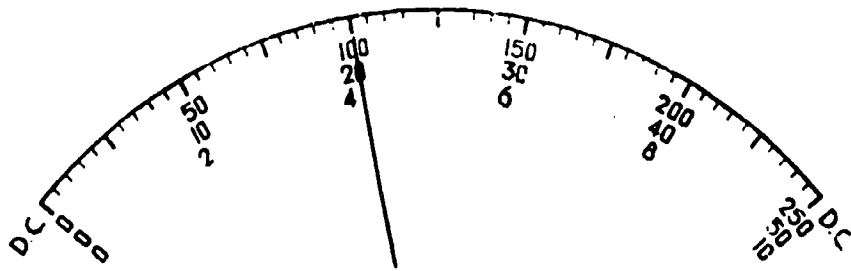

What is the current reading indicated below? _____ ma

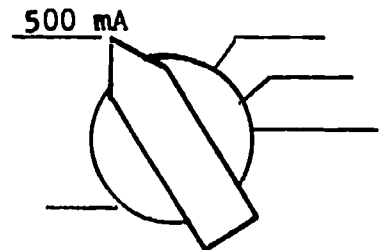
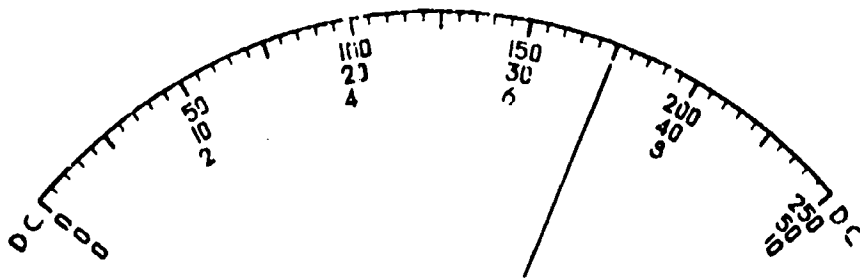

(350)

48. What is the current reading indicated below?

- ___ a. 40 ma
- ___ b. 430 ma
- ___ c. 230 ma
- ___ d. 80 ma

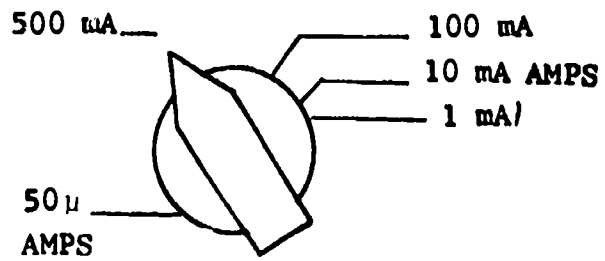
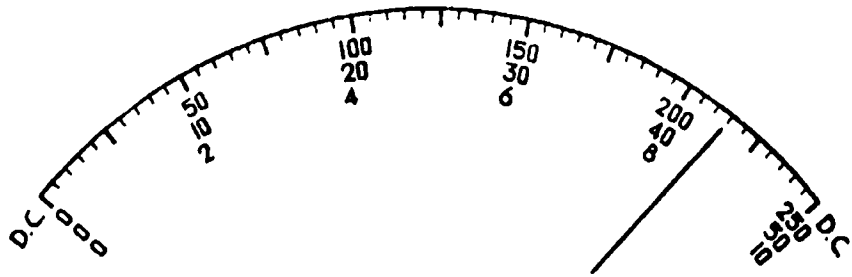

(THIS IS A TEST FRAME. COMPARE YOUR ANSWER WITH THE CORRECT ANSWER GIVEN AT THE TOP OF THE NEXT PAGE.)

ANSWER - TEST FRAME 48

b. 430 ma

IF YOUR ANSWER MATCHES THE CORRECT ANSWER, YOU MAY GO ON TO TEST FRAME 59. OTHERWISE, GO BACK TO FRAME 45 AND TAKE THE PROGRAMMED SEQUENCE BEFORE TAKING TEST FRAME 48 AGAIN.

49. When the range switch is in the 50 μ a position or the 500 ma position, what meter scale is used?

- a. 0-50
 b. 0-10
 c. 0-250
-
-

(a) 0-50

50. Check the statements that are correct.

- a. When the range switch is in the 500 ma position, current value is read directly on the 0-50 DC scale.
 b. When the range switch is in the 50 μ a position, current is read directly on the 0-50 DC scale.
 c. When the range switch is in the 500 ma position, the value indicated on the 0-50 DC scale must be multiplied by 10 to obtain the correct current value.
 d. When the range switch is in the 50 μ a position, the value indicated on the 0-50 DC scale must be multiplied by 10 to obtain the correct current value.
-
-

(b. When the range switch is in the 50 μ a position, current is read directly on the 0-50 DC scale.; c. When the range switch is in the 500 ma position, the value indicated on the 0-50 DC scale must be multiplied by 10 to obtain the correct current value.)

51. For the remaining range positions, 1 ma, 10 ma, and 100 ma, the 0-10 DC scale is used. If the range switch is in the 100 ma position, the value indicated on the 0-10 DC scale must be multiplied by 10.

What is the current reading indicated below?

- a. 30 ma
- b. 90 ma
- c. 450 ma
- d. 8 ma

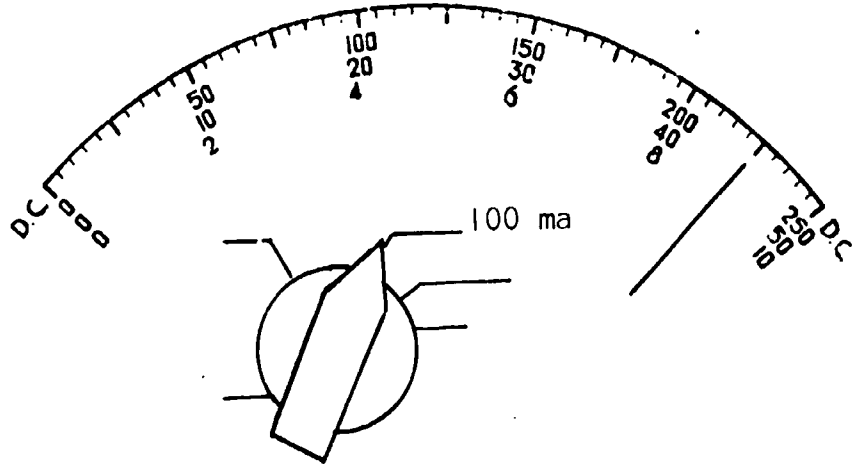

(b) 90 ma

52. In the drawing below, how many milliamps will cause full meter deflection? _____ ma

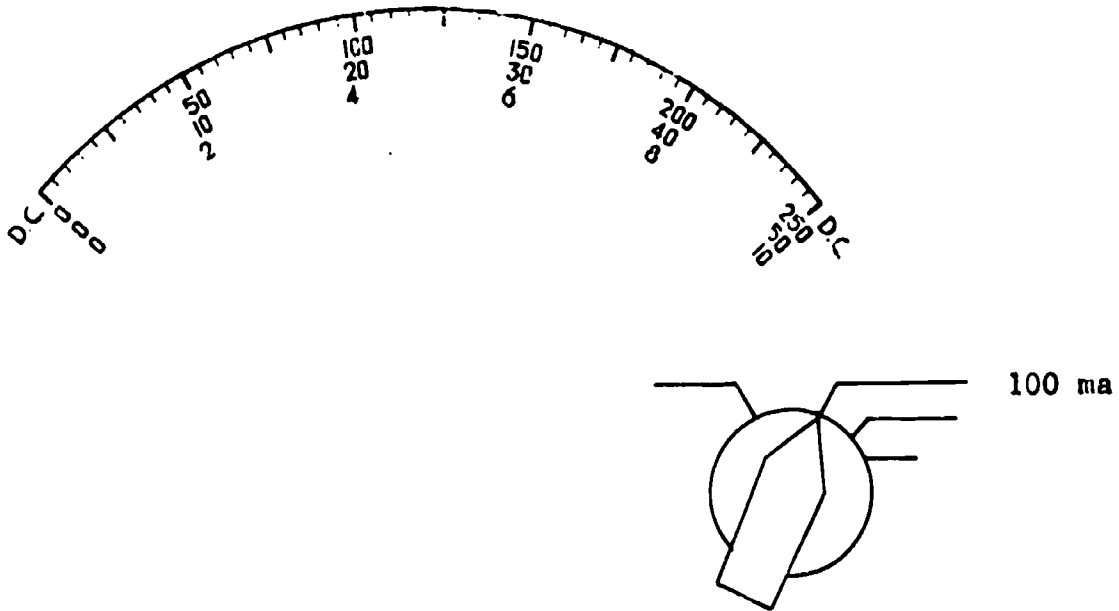

(100)

53. What is the value of current indicated? _____ ma

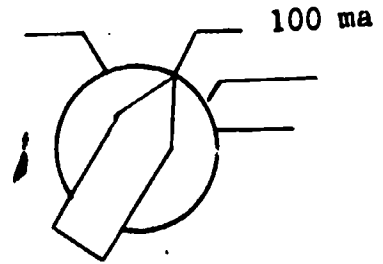
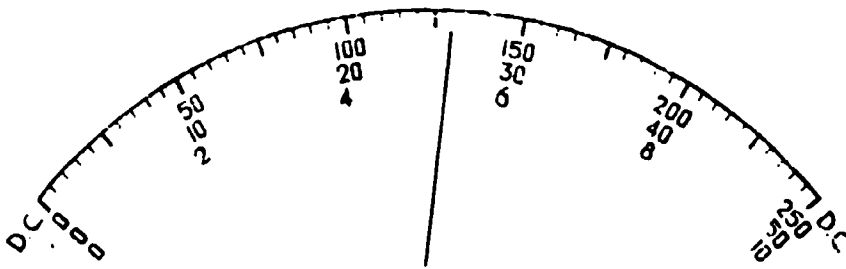

(52 ma)

54. If the range switch is set on the 10 ma position, current is read directly on the 0-10 DC scale.

What would the current reading be for the illustration?

- _____ a. 46 ma
- _____ b. 230 ma
- _____ c. 5 ma
- _____ d. 4.6 ma

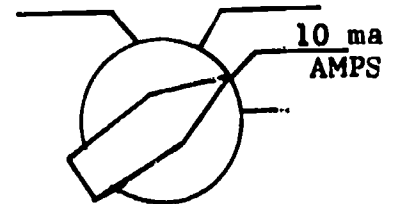
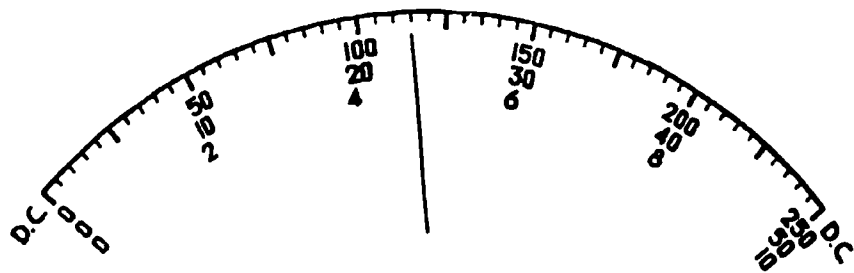

(d) 4.6 ma

55. What is the value of current indicated by the meter? _____

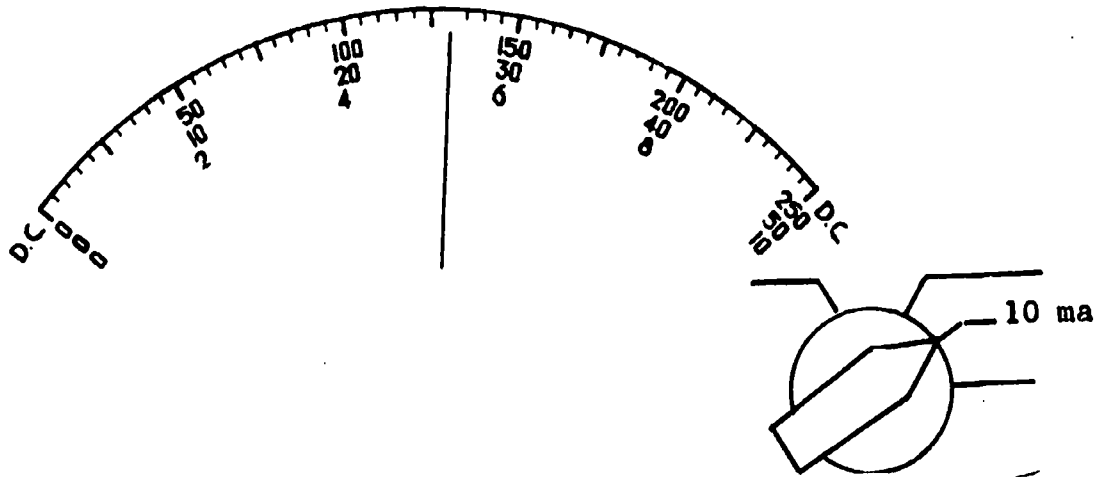

(5.2 ma)

56. If the range switch is set on the 1 ma position, current is read on the 0-10 DC scale and each number is made a decimal: 0.1, 0.2, 0.3, 0.4, 0.5, etc. Here you are really dividing by 10. For example, with the meter set up as shown below, current flow would be .2 ma.

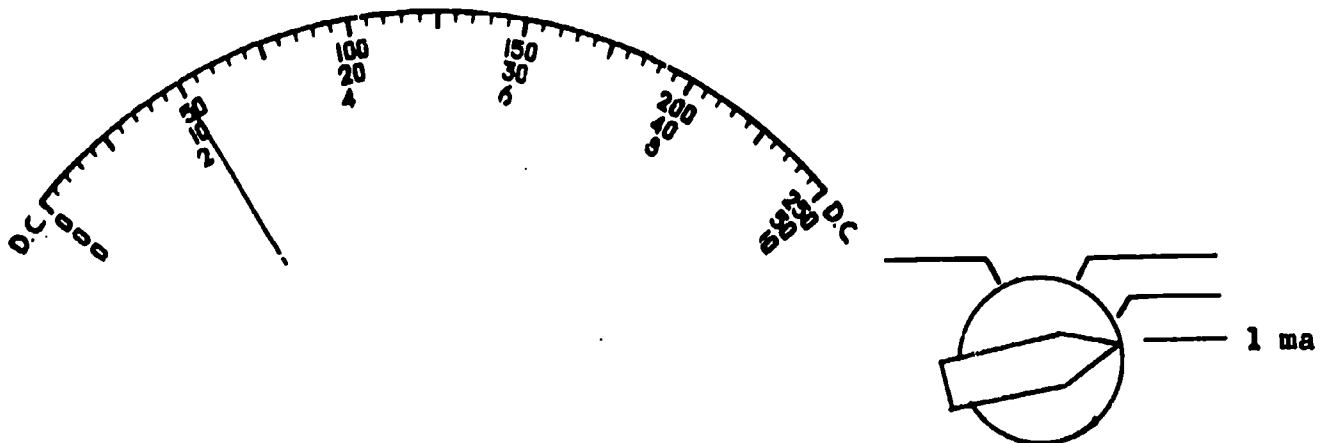

With the range switch on 1 ma, what is the current reading indicated below?

- _____ a. 4 ma
- _____ b. 0.46 ma
- _____ c. 4.0 ma
- _____ d. 4.3 ma

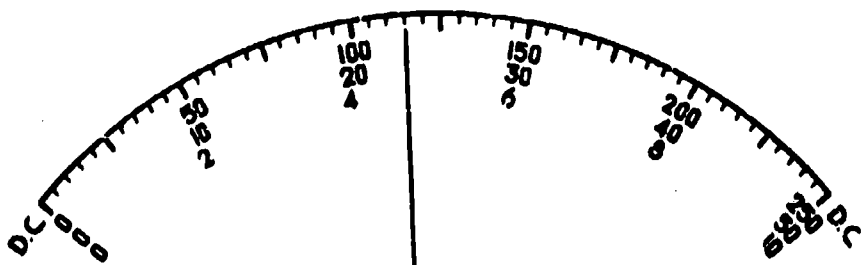

(b) 0.46 ma

57. What is the value of current indicated by the meter? _____

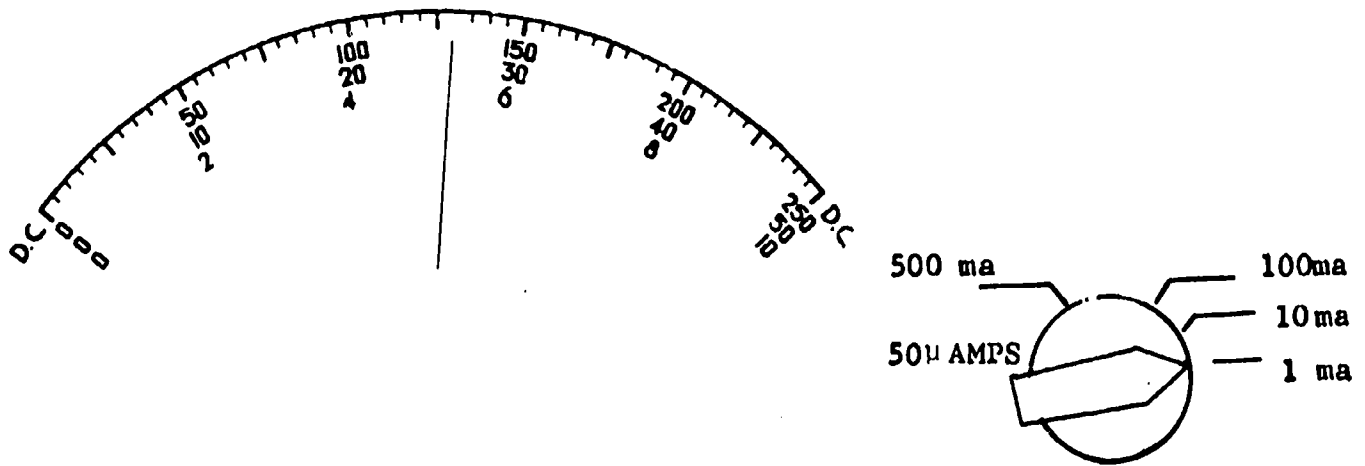

 (0.52 ma)

58. Match the meter DC scale to the range switch position.

Range Switch Position	Meter DC Scale
___ 1. 50 µa	a. 0-50
___ 2. 1 ma	
___ 3. 500 ma	b. 0-10
___ 4. 10 ma	
___ 5. 100 ma	

 (1. a; 2. b; 3. a; 4. b; 5. b)

59. Interpret the meter DC scale below by matching the indicated current to the range switch position.

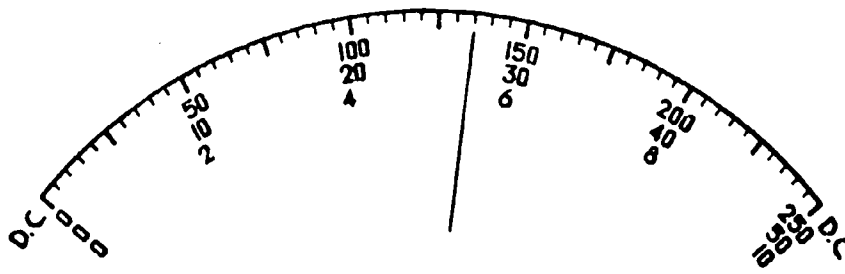

<u>Range Switch Position</u>	<u>Current</u>
<input type="checkbox"/> 1. 10 ma	a. 270 milliamps
<input type="checkbox"/> 2. 50 μ a	b. .54 milliamps
<input type="checkbox"/> 3. 1 ma	c. 27 microamps
<input type="checkbox"/> 4. 100 ma	d. 54 milliamps
<input type="checkbox"/> 5. 500 ma	e. 5.4 milliamps

(THIS IS A TEST FRAME. COMPARE YOUR ANSWERS WITH THE CORRECT ANSWERS GIVEN AT THE TOP OF THE NEXT PAGE.)

ANSWERS - TEST FRAME 59

1. e
2. c
3. b
4. d
5. a

IF ALL YOUR ANSWERS MATCH THE CORRECT ANSWERS, YOU MAY GO ON TO TEST FRAME 61. OTHERWISE, GO BACK TO FRAME 49 AND TAKE THE PROGRAMMED SEQUENCE BEFORE TAKING TEST FRAME 59 AGAIN.

60. The jacks used for DC current measurements in the 0-1 ma-10 ma-100 ma-500 ma ranges are marked common (-) and positive (+). These jacks are located in the lower left hand corner of the meter. Using the illustration below, locate on your multimeter the common (-) jack and the positive (+) jack.

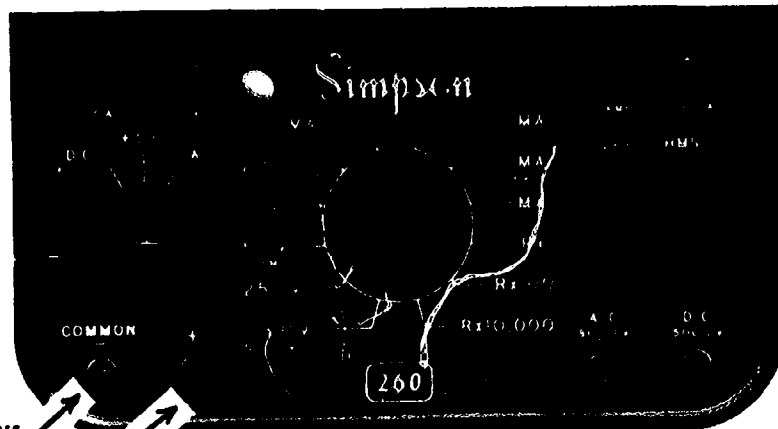

COMMON (-) JACK

POSITIVE (+) JACK

(Go to next frame)

61. On the illustration below, check the arrows which point to the jacks used when making current measurements in the ranges of 0-1 ma-10 ma-100 ma-500 ma.

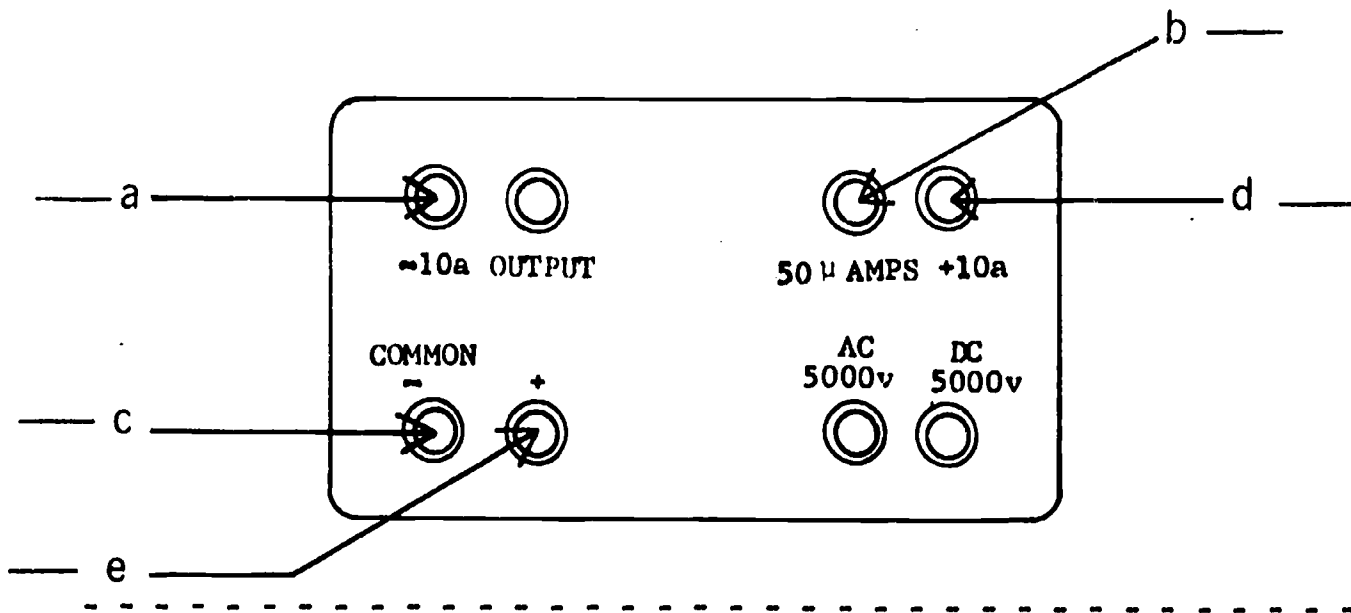

(THIS IS A TEST FRAME. COMPARE YOUR ANSWERS WITH THE CORRECT ANSWERS GIVEN AT THE TOP OF THE NEXT PAGE.)

ANSWERS - TEST FRAME 61

c; e

IF ALL YOUR ANSWERS MATCH THE CORRECT ANSWERS, YOU MAY GO ON TO TEST FRAME 64. OTHERWISE, GO BACK TO FRAME 60 AND TAKE THE PROGRAMMED SEQUENCE BEFORE TAKING TEST FRAME 61 AGAIN.

62. Using Practice Board 0-1, a $330\ \Omega$ resistor, and one dry cell, construct a series circuit as shown below.

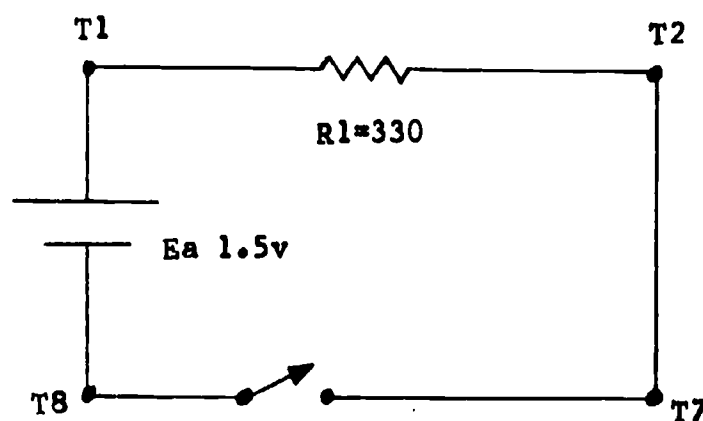

Make sure switch is open.

(Go to next frame.)

63. Following the steps below, measure current and record it in the space provided.

1. Set function switch to +DC.
2. Connect black test lead in the common (-) jack and the red test lead in the (+) jack.
3. Set range switch to the highest ma setting (500 ma). Since the exact current flow is still unknown, starting at the highest ma range-switch setting can prevent damage to the meter.
4. Ensure switch is open, then break the circuit between T2 and T7, and place the meter in series with the load. Remember, polarity must be observed.
5. Energize circuit and observe the meter pointer. If pointer deflects to the left, polarity is opposite to that which was anticipated. De-energize the circuit and reverse meter leads or turn the function switch to -DC. Energize the circuit again.
6. Read the current on the 0-50 DC scale. If necessary, move the range switch to one of the other ma positions until you get as close to a mid-scale reading as possible. After you have taken and recorded your reading, de-energize circuit and remove the test leads from the circuit.

Circuit current _____ ma

(approximately 4.4 ma)

64. Construct the series circuit shown below. Then measure the current and record it in the space provided.

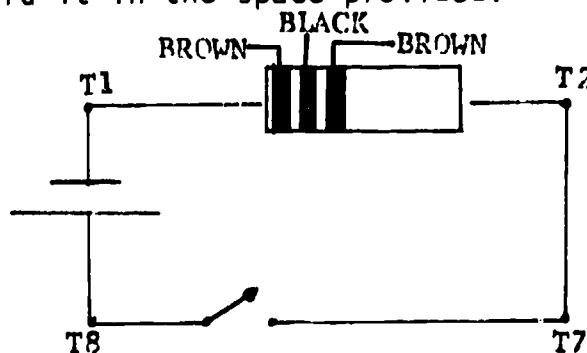

Circuit current = _____

(THIS IS A TEST FRAME. COMPARE YOUR ANSWER WITH THE CORRECT ANSWER GIVEN AT THE TOP OF THE NEXT PAGE.)

ANSWER - TEST FRAME 64

Approximately 15 ma

IF YOUR ANSWER MATCHES THE CORRECT ANSWER, YOU MAY GO ON TO FRAME 65. OTHERWISE, GO BACK TO FRAME 62 AND TAKE THE PROGRAMMED SEQUENCE BEFORE TAKING TEST FRAME 64 AGAIN.

65. Complete the following chart for using the Simpson 260-5P multi-meter as an ammeter.

CURRENT RANGE	FUNCTION SW. POSITION	RANGE SW. POSITION	METER DC SCALE	TEST LEADS POSITION	
				RED	BLACK
0-50 μ a					
0-1 ma					
0-10 ma					
0-100 ma					
0-500 ma					

CURRENT RANGE	FUNCTION SW. POSITION	RANGE SW. POSITION	METER DC SCALE	TEST LEADS POSITION	
				RED	BLACK
0-50 μ a	+DC	50 μ a	0-50	50 μ a	(-) common
0-1 ma	+ or -DC	1 ma	0-10	(+)	(-) common
0-10 ma	+ or -DC	10 ma/amps	0-10	(+)	(-) common
0-100 ma	+ or -DC	100 ma	0-10	(+)	(-) common
0-500 ma	+ or -DC	500 ma	0-50	(+)	(-) common

66. Listed below are the steps for measuring 0-10 amps DC. At this time, you will not actually take current measurements using this range; however, it is important to understand how to set up the meter to do so.

1. Place function switch at +DC.
2. Connect black test lead in the -10 a jack and the red test lead in the +10 a jack.
3. Set the range switch on 10 a. (Note: This is also the common setting for 10 ma.)
4. De-energize circuit to be measured and place the meter in series with load while observing proper polarity. Red test lead to (+) black test lead to (-).
5. Energize circuit and observe meter pointer. If pointer deflects to left, de-energize circuit and reverse the meter leads. Energize circuit again. (Note: Function switch has no effect on polarity in the 0-10 amp range.)
6. Read the current directly on the 0-10 DC scale.

(Go to next frame.)

67. Refer to step 6 in frame 66. How much current would be flowing in the meter below? _____ amps.

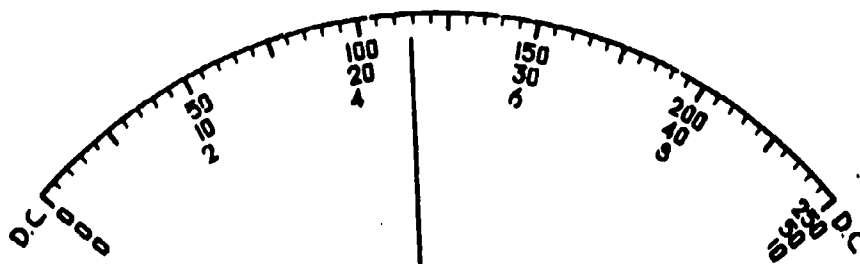

(4.6 amps)

IF YOUR ANSWERS ARE CORRECT, YOU MAY TAKE THE PROGRESS CHECK, OR YOU MAY STUDY ANY OF THE OTHER RESOURCES LISTED. IF YOU TAKE THE PROGRESS CHECK AND ANSWER ALL THE QUESTIONS CORRECTLY, GO ON TO THE NEXT LESSON. IF NOT, STUDY ANY METHOD OF INSTRUCTION YOU WISH UNTIL YOU CAN ANSWER ALL THE QUESTIONS CORRECTLY.

SUMMARY
LESSON 1

Measuring Current in a Series Circuit

We have already indicated that a series circuit has only one path for current to flow, but a parallel circuit has two or more current paths.

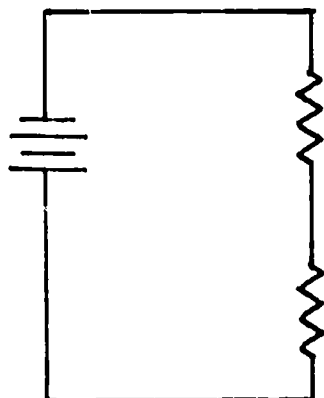

SERIES

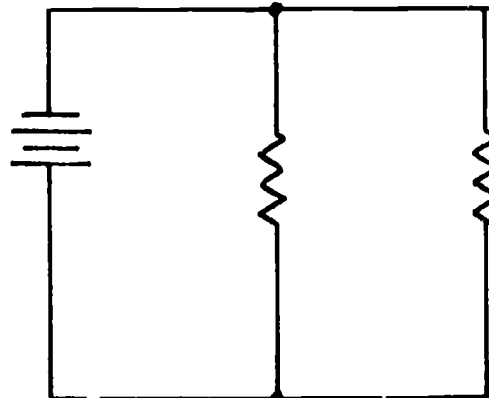

PARALLEL

Remember that when you measure current you must connect the ammeter in series, not in parallel.

In this lesson, you will learn to use the multimeter to measure current. It works just like the simple ammeter, but the switches make it a little more complicated to set up. The ammeter ranges of the Simpson 260 are 0 to 1 milliamperes, 0 to 10 milliamperes, 0 to 100 milliamperes, and 0 to 500 milliamperes. There are two special ranges, 0 to 50 microamperes and 0 to 10 amperes, that require the test leads be plugged into special jacks. All DC current values are read on the scale marked DC, using the numbers which correspond to the range switch setting.

If you feel you know enough about using the multimeter as an ammeter, perform the experiments on pages 9 and 19 before you take the progress check. If not, study the Narrative and/or the programmed sequence prior to performing the experiments.

AT THIS POINT, YOU MAY TAKE THE LESSON PROGRESS CHECK, OR YOU MAY STUDY THE LESSON NARRATIVE OR THE PROGRAMMED INSTRUCTION OR BOTH. IF YOU TAKE THE PROGRESS CHECK AND ANSWER ALL OF THE QUESTIONS CORRECTLY, GO TO THE NEXT LESSON. IF NOT, STUDY ANOTHER METHOD OF INSTRUCTION UNTIL YOU CAN ANSWER ALL THE QUESTIONS CORRECTLY.

BASIC ELECTRICITY AND ELECTRONICS
INDIVIDUALIZED LEARNING SYSTEM



M O D U L E F O U R
L E S S O N I I

Voltage in a Series Circuit

Study Booklet

BUREAU OF NAVAL PERSONNEL
January 1972

64/65

OVERVIEW
LESSON 11

Voltage in a Series Circuit

In this lesson, you will study and learn about the following:

- difference in potential
- where potential difference exists in a circuit
- voltage rise
- voltage drop

Each of the above topics will be discussed in the order listed. As you proceed through this lesson, observe and follow directions carefully.

BEFORE YOU START THIS LESSON, PREVIEW THE LIST OF STUDY RESOURCES ON THE NEXT PAGE.

LIST OF STUDY RESOURCES
LESSON II

Voltage in a Series Circuit

To learn the material in this lesson, you have the option of choosing, according to your experience and preferences, any or all of the following:

STUDY BOOKLET:

Lesson Narrative
Programmed Instruction
Lesson Summary

ENRICHMENT MATERIAL:

NAVPERS 93400A-1a "Basic Electricity, Direct Current."
Fundamentals of Electronics. Bureau of Naval Personnel.
Washington, D.C.: U.S. Government Printing Office, 1965.

You may study whatever learning materials you feel are necessary to answer the questions in the Lesson Progress Check. All your answers must be correct before you can go to Lesson III. Remember your instructor is available at all times for any assistance you may need.

YOU MAY NOW STUDY ANY OR ALL OF THE STUDY RESOURCES LISTED ABOVE. YOU MAY TAKE THE PROGRESS CHECK AT ANY TIME.

NARRATIVE
LESSON 11

Voltage in a Series Circuit

Difference in Potential

You know you can measure current anywhere in a series circuit and the ammeter will read the same number of amps. However, when measuring voltage, you will get a reading only between points where a difference in electrical potential exists. You recall that this potential difference is called voltage. This means voltage is measurable only between two points where one point is more or less negative than the other point. Keep in mind that if we say more negative, that also means less positive; or, if we say less negative, that also means more positive.

Where Potential Difference Exists in a Circuit

A potential difference exists in a circuit:

1. Wherever energy is being applied to the circuit. This is referred to as the voltage rise or rise in potential.
2. Wherever energy is being converted by the load. This is called a fall in potential and is often referred to as a voltage drop.

Answer this question.

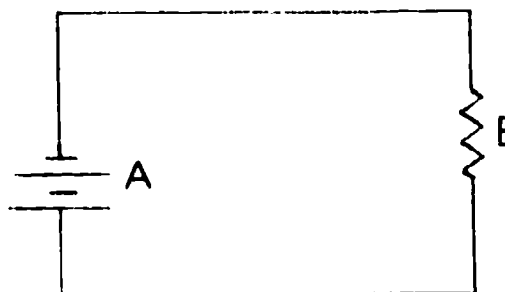

At what point in the above circuit does the voltage drop take place? _____

Answer: At the load (B)

Voltage Rise

Recall how chemical action within a cell tends to cause electrons to pile up at the outer terminal of a dry cell, making this terminal negative. You also know that this

causes the center terminal to be deficient in electrons. The center terminal now is less negative than the outer terminal. When one point is more negative (-terminal) than another (+terminal), we say that a difference in potential exists between these two points.

If voltage is measured across these points, as shown in the figure below, you will get a voltage reading of about 12 volts.

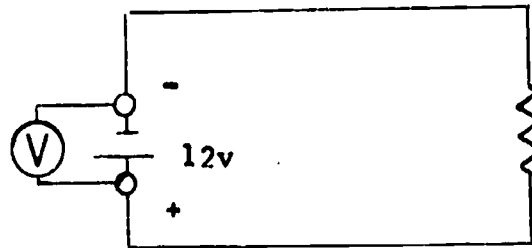

This indicates a rise in potential of 12 volts or that you have an applied voltage of 12 volts. You will normally see applied voltage abbreviated as E . A voltage rise may also be abbreviated E_s (for source voltage),^a or E_T (for total voltage).

Voltage Drop

When voltage is applied to a circuit, you know that the electrons piled up at the negative terminal cause current to flow through the external circuit from the more negative post back around to the positive (less negative) post.

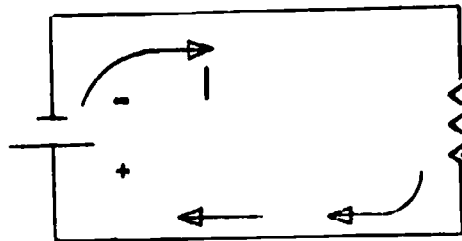

In the circuit below, electrons have about the same amount of negative potential at the top of the resistor as when they left the source. If you were to connect the probes of a voltmeter to the points shown in the illustration, the meter would read 0, because almost no difference in potential exists.

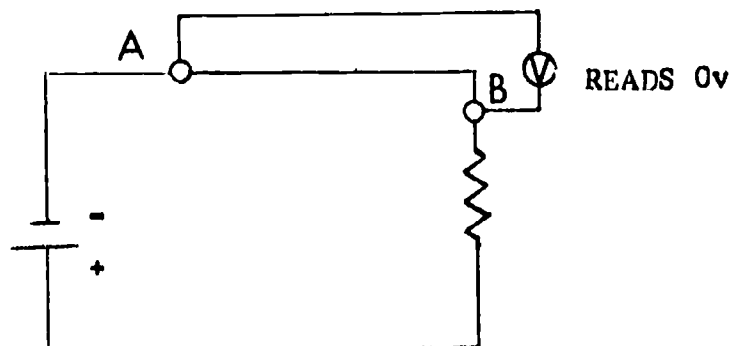

We can therefore assume that free electrons at the top of resistor (B) are being pushed away from the negative terminal of the source.

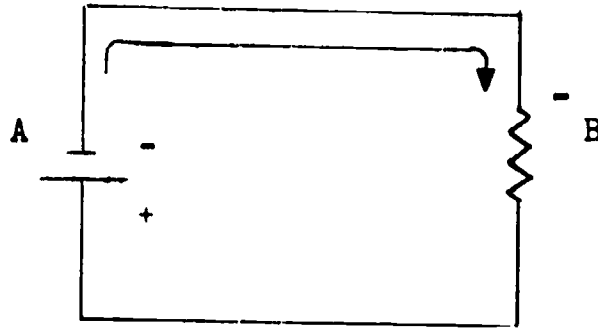

Because the load offers resistance to the electrons as they move through it, the electrons give up their energy in the form of heat. Remember, energy cannot be destroyed; it can only be changed from one form to another.

As electrons move through a resistance they give up their energy. Upon leaving the end of the resistor, nearly all the potential energy has been changed to heat energy. This loss of potential is called a fall in potential or a voltage drop. This causes the bottom of the load resistance to be less negative than the top, so the bottom is designated as having a positive polarity.

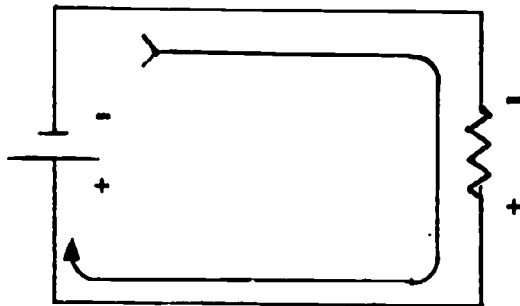

A difference of potential has now been developed across the load. This difference in potential is the voltage drop. Note (-) to (+) here is a drop since the energy supplied by the source is dissipated in the load.

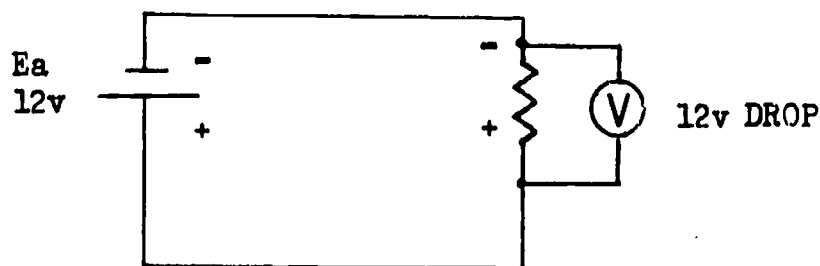

It is important here to realize that a voltage drop will only be developed when current is flowing through some opposition. Although a very small energy loss occurs as current flows through the conductor, the resistance of the conductor is very low and is negligible in most practical applications. In later units we will learn how to compute voltage drops in a circuit.

Rules for Voltage in Series Circuits

Here are two "golden rules" that will prove to be invaluable. This first rule is often called Kirchhoff's Voltage Law.

Rule 1. The total voltage drop in a series circuit will always equal the applied voltage.

Answer this question.

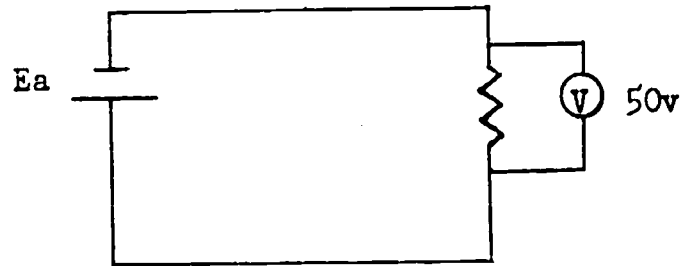

What is the value of applied voltage (E_a)?

- a. 100 v
- b. 0 v
- c. 50 v
- d. 25 v

Answer: c.

This rule holds true no matter how many resistors are in a series circuit.

Note: We number the resistors R1, R2, and R3 to distinguish each particular one.

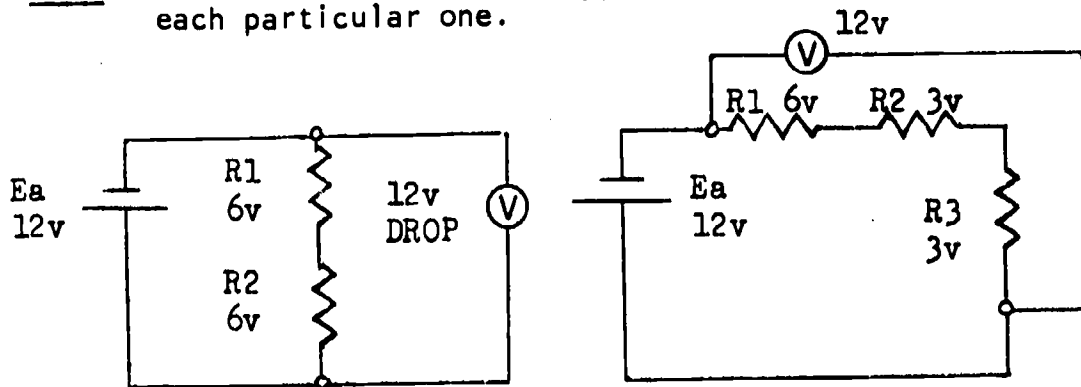

Voltage drops, then, are designated as E_{R1} , E_{R2} , and E_{R3} .

Answer this question

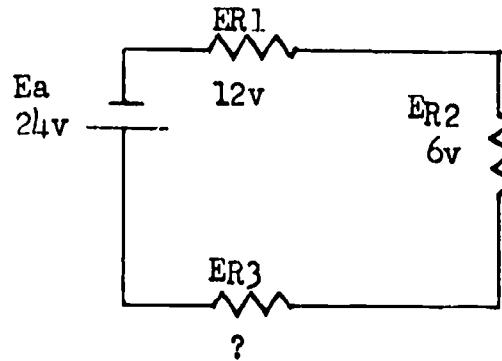

Which of the below is the voltage drop across R3?

- a. 24v
 b. 6v
 c. 0v

Answer: b. 6v

The total of the voltage drops across all the resistors will always equal the applied voltage. No matter how many resistors are in a series circuit, they will use the total energy put into the circuit by the source. The ohmic value of each resistor determines how much voltage is dropped across it.

Another way of stating the rule is: The sum of the voltage drops in a series circuit will always equal the applied voltage.

Rule 2. In a series circuit the largest voltage drop will take place across the largest resistance.

For example, if you have a circuit with two resistors, one of them 10 ohms and the other 5 ohms, the greatest voltage drop will occur across the 10-ohm resistor.

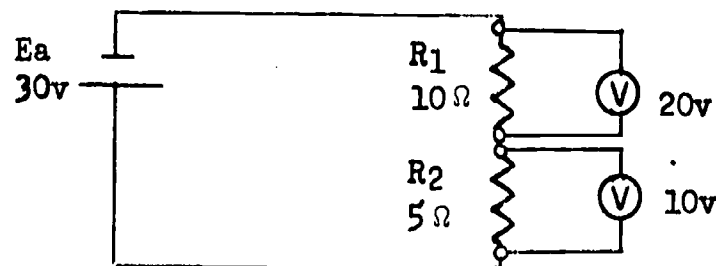

The 10-ohm resistor drops 20 volts while the 5-ohm resistor drops 10 volts. Note the sum of these two: $10\text{ v} + 20\text{ v} = 30\text{ v}$, the E_a .

Let's look at the second rule in a slightly different manner.

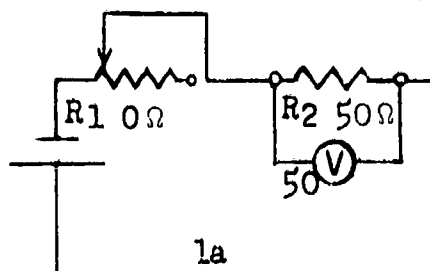

In this schematic, R1 is a variable resistor and we can assume that because R2 is dropping the entire amount of voltage that R1 is adjusted to 0 ohms.

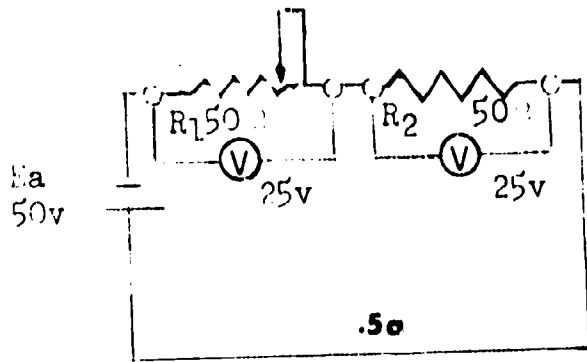

Now if R_1 is set to the 50-ohm position, notice that the voltage drop across R_2 decreases to 25 volts and the voltage drop across R_1 increases to 25 volts. This is an important concept to remember. Let's see if we can relate it to our two voltage rules.

Rule 1 - Sum of voltage drops equals applied voltage. (It did in both circuits.) Notice that E_a is 50 volts in both circuits, and that if the voltage drop across R_2 decreases, then the voltage drop across R_1 has to increase.

Rule 2 - Greatest voltage drop will exist across largest resistance. Notice as the value of R_1 increases, then the voltage drop across it also increases. If R_1 were increased above 50 ohms, then more voltage would be dropped across R_1 than R_2 .

AT THIS POINT, YOU MAY TAKE THE PROGRESS CHECK, OR YOU MAY STUDY ANY OF THE OTHER RESOURCES LISTED. IF YOU TAKE THE PROGRESS CHECK AND ANSWER ALL OF THE QUESTIONS CORRECTLY, GO TO THE NEXT LESSON. IF NOT, STUDY ANY METHOD OF INSTRUCTION YOU WISH UNTIL YOU CAN ANSWER ALL THE QUESTIONS CORRECTLY.

PROGRAMMED INSTRUCTION
LESSON 11

Voltage in a Series Circuit

TEST FRAMES ARE 20 AND 24. AS BEFORE, GO FIRST TO TEST FRAME 20 AND SEE IF YOU CAN ANSWER ALL THE QUESTIONS THERE. FOLLOW THE DIRECTIONS GIVEN AFTER THE TEST FRAME.

1. You know from the previous lesson that current can be measured anywhere in a series circuit. Voltage, however, can be measured only between two points where one point is more (or less) negative than another point.

Voltage is measurable:

- _____ a. where a difference in potential exists in a circuit.
_____ b. anywhere in a series circuit.

_____ (a) where a difference in potential exists in a circuit.

2. A difference in potential or potential difference can only exist where electrical energy is generated or where it is used by a load or resistance.

At what points in the circuit below can voltage be measured?

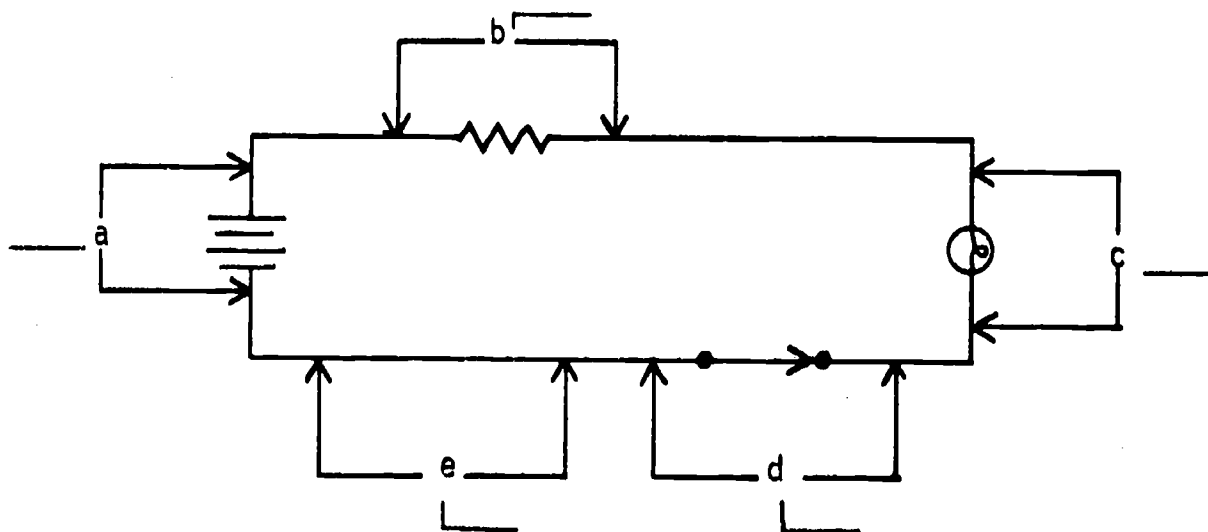

_____ (a; b; c)

3. At what places in a circuit does a potential difference exist?

- a. at the source which supplies electrical energy to the circuit.
- b. at the conductor which carries electrical energy to the load
- c. at the load which receives and uses electrical energy

(a. at the source which supplies electrical energy to the circuit; and, c. at the load which receives and uses electrical energy.)

4. The potential difference is developed across the load by current flowing through the load. Since we know that current in a circuit outside the source flows from negative to positive, the point where current enters the load device is labeled negative and the point of departure is labeled positive.

Label the voltage drops with proper polarities.

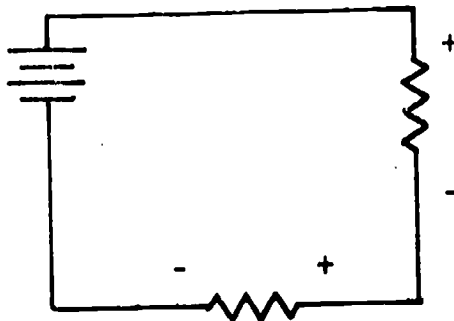
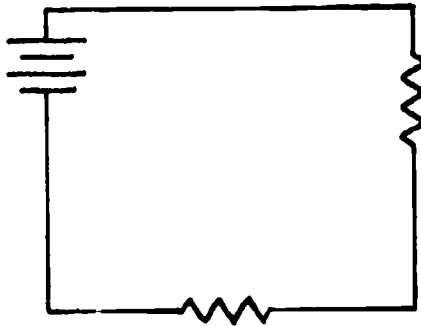

5. Which circuit has a difference in potential across the load?

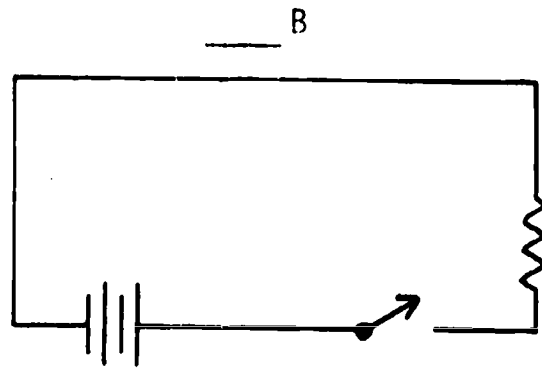
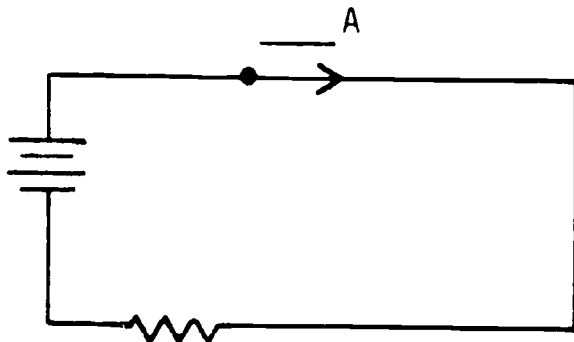

(A)

6. In a circuit with an open switch, there will be some movement of electrons within the wires of the circuit. This movement will continue until the contact points of the open switch are at the same electrical potential as the terminals of the source to which they are attached.

What potential difference exists across the switch in the circuit illustrated below?

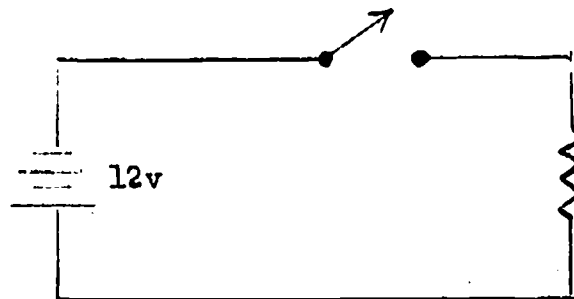

(The same as the source or 12v)

7. Between what points in the circuit below does a potential difference exist?

- a. A and B
- b. B and C
- c. C and D
- d. D and E

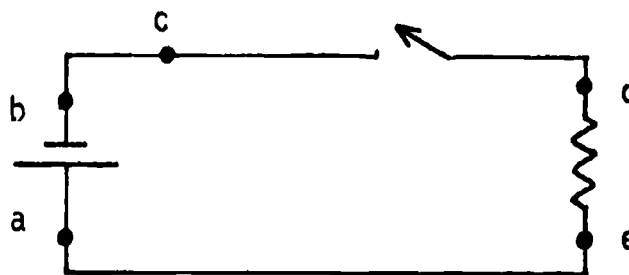

(a. A and B; c. C and D)

8. A potential difference across a source is called a voltage rise or rise in potential.

At what points in the circuit below does a voltage rise exist?

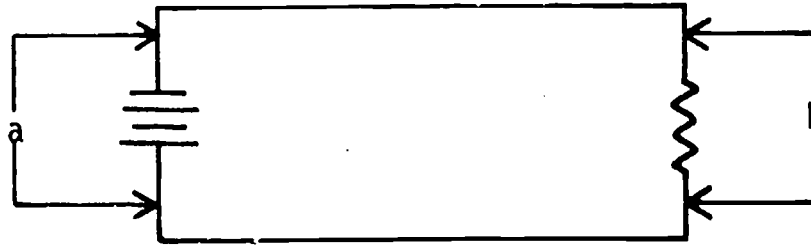

(a)

9. The place in the circuit where voltage is used by the load is referred to as the voltage drop or fall in potential.

At what points in the circuit below does a voltage drop exist?

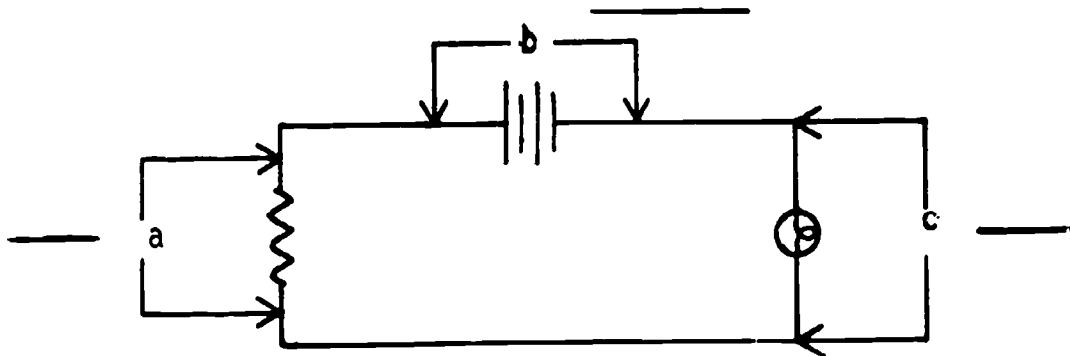

(a, c)

10. Match.

- | | |
|--|-----------------|
| ___ 1. where energy is being used by a load | a. voltage drop |
| ___ 2. where voltage is being applied to the circuit at the source | b. voltage rise |
| ___ 3. rise in potential | |
| ___ 4. fall in potential | |

(1. a; 2. b; 3. b; 4. a)

11. Study the schematic, then answer the questions below.

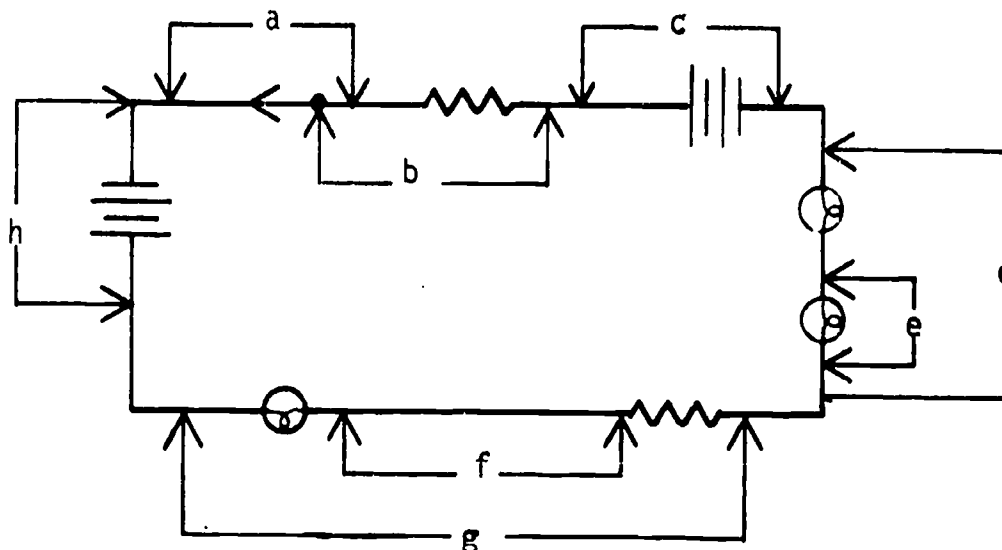

1. At what point does a voltage rise exist? _____
2. At what points does a voltage drop exist? _____

(1. h, c) (2. b, d, e, g)

12. Match the letters on the schematic to the corresponding voltage concepts.

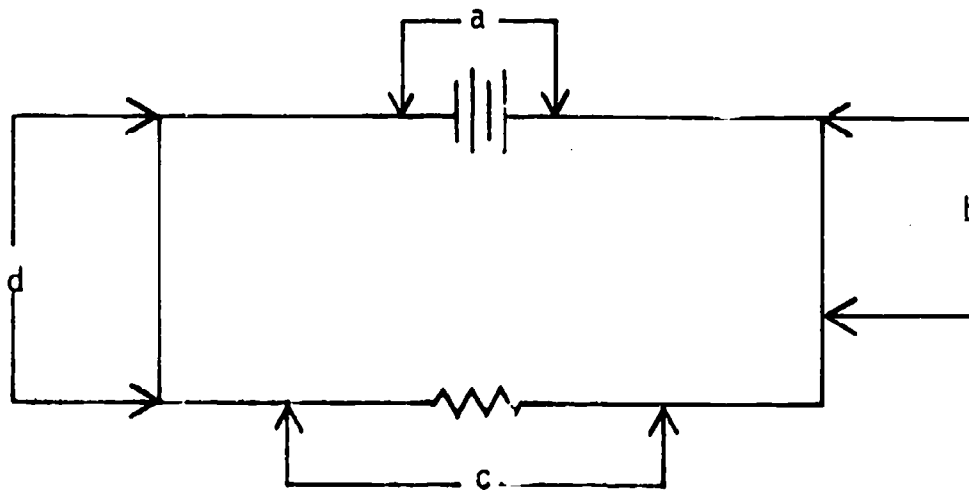

- _____ 1. voltage rise
- _____ 2. zero (0) difference in potential
- _____ 3. voltage drop

(1. a) (2. b and d) (3. c)

13. The voltage rise at the source is often abbreviated E_s (for source voltage), E_a (for applied voltage), or E_T (for total voltage).

Which circuits are correctly labeled?

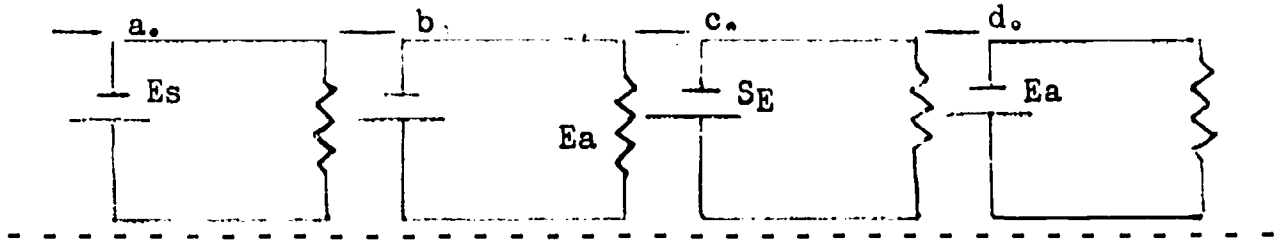

(a, d)

14. A voltage drop is often abbreviated just E , but if there are several voltage drops in the circuit, each is labeled as E_{R1} , E_{R2} , etc., for differentiation.

Check the circuits that have the voltage drops correctly labeled.

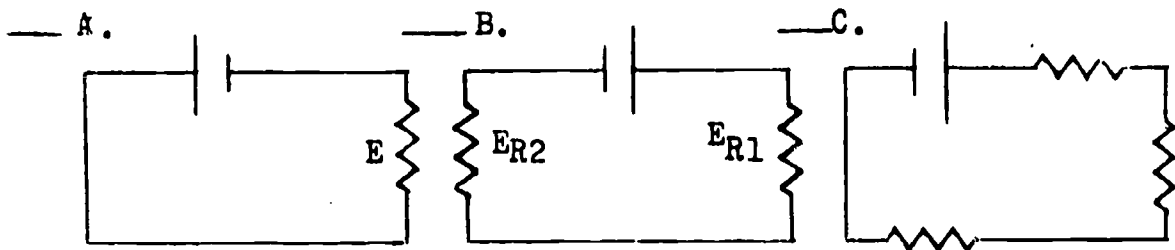

(A, B)

15. Which circuit has the polarity of the voltage drops correctly labeled?

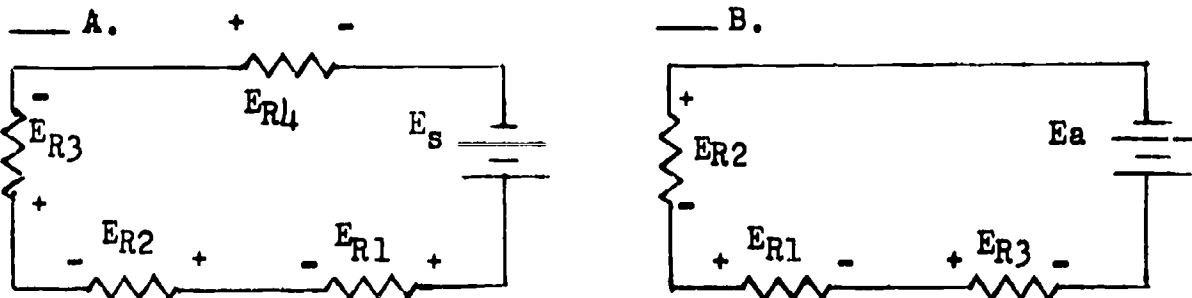

(A)

(REMEMBER: Polarities are labeled negative to positive across the load in the direction of current flow.)

16. In a dry cell, chemical energy is converted and produces electrical potential energy. When an electrical load is connected to a voltage source (such as a dry cell) most of the electrical energy supplied to the load is changed to heat (or other forms of energy) within the load. The change to a different form of energy causes the electrical energy to decrease. This decrease in electrical energy within the load is called voltage drop. For example, if the potential energy given to free electrons, as they are moved by the EMF within a cell, is 1.5V, then the same amount of energy, 1.5V must be given up by free electrons as they pass through the load.

In the circuit below, how much voltage is dropped across the load? _____

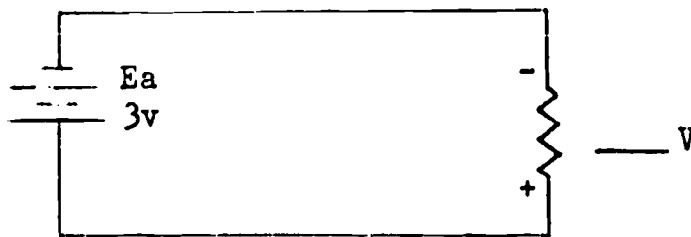

(3 volts)

17. Regardless of the number of loads in a series circuit, the total applied voltage will be divided between the loads.

What is the voltage dropped (E_{R3}) across R3 in the circuit?

- ___ a. 1.5 v
- ___ b. 4.5 v
- ___ c. 3.5 v
- ___ d. 1 v

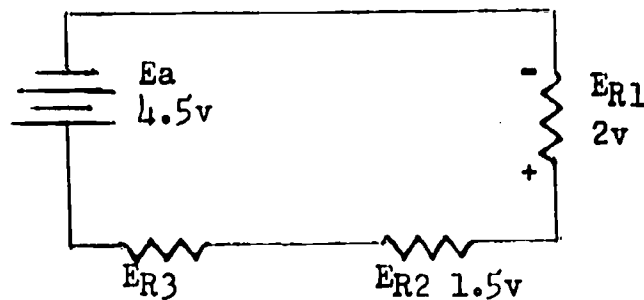

(d) 1 v

18. In a series circuit, the sum of the voltage drops will always equal the applied voltage. This is commonly called Kirchhoff's Voltage Law.

What is the voltage drop (E_{R2}) across R2 in the circuit below?

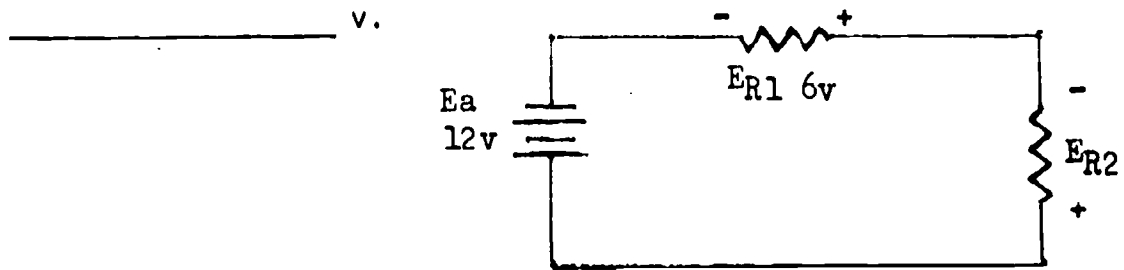

(6 v)

19. What is the applied voltage in the circuit below?

- ___ a. 12v
- ___ b. 3v
- ___ c. 6v
- ___ d. 18v

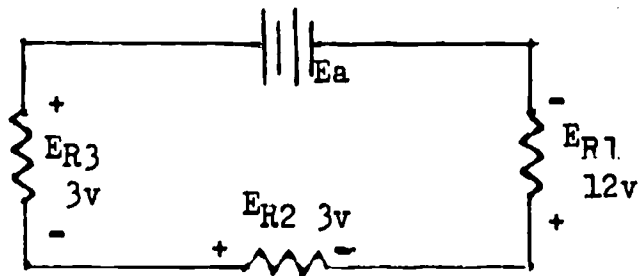

(d) 18v

20. Study the schematic, then check the statements that are true.

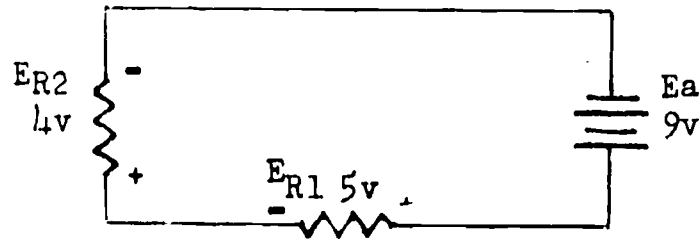

- ___ a. The voltage rise is equal to the sum of the voltage drops.
- ___ b. The total voltage dropped is 13 volts.
- ___ c. The voltage drop across R1 is greater than the voltage drop across R2.
- ___ d. The voltage rise at the source is 4 volts.
- ___ e. The total applied voltage is 18 volts.
- ___ f. The rise in potential is 9 volts.
- ___ g. The polarities indicated for both voltage drops are correct.
- ___ h. The polarity indicated for E_{R1} is correct.
-

(THIS IS A TEST FRAME. COMPARE YOUR ANSWERS WITH THE CORRECT ANSWERS GIVEN AT THE TOP OF THE NEXT PAGE.)

ANSWERS - TEST FRAME 20

- a. The voltage rise is equal to the sum of the voltage drops.
- c. The voltage drop across R1 is greater than the voltage drop across R2.
- f. The rise in potential is 9 volts.
- g. The polarities indicated for both voltage drops are correct.
- h. The polarity indicated for E_{R1} is correct.

IF ALL YOUR ANSWERS MATCH THE CORRECT ANSWERS, YOU MAY GO ON TO TEST FRAME 24. OTHERWISE, GO BACK TO FRAME 1 AND TAKE THE PROGRAMMED SEQUENCE BEFORE TAKING TEST FRAME 20 AGAIN.

21. The second rule for a series circuit is:

In a series circuit, the largest voltage drop will take place across the greatest resistance.

Which resistor will have the largest voltage drop?

- a. R1
- b. R2
- c. R3

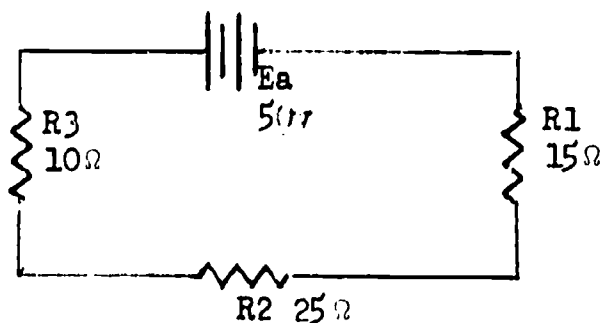

(b) R2

22. Study the schematic below.

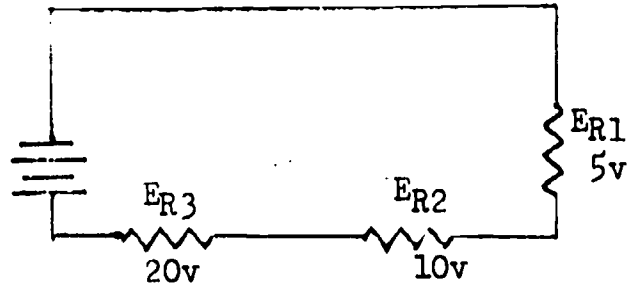

Which resistor has the largest ohmic value?

- a. R1
- b. R2
- c. R3

(c) R3

23. The largest voltage drop in a series circuit will occur across the:

- a. resistor closest to the negative side of the source.
- b. resistor with the highest ohmic value.
- c. load having the least resistance.

(b) resistor with the highest ohmic value.

24. Circle the resistor in each schematic that will have the largest voltage drop.

A.

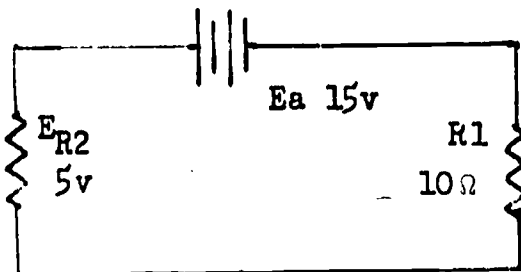

B.

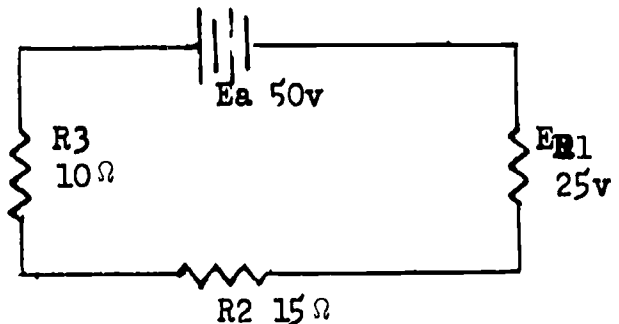

(THIS IS A TEST FRAME. COMPARE YOUR ANSWERS WITH THE CORRECT ANSWERS GIVEN ON THE TOP OF THE NEXT PAGE.)

ANSWERS - TEST FRAME 24

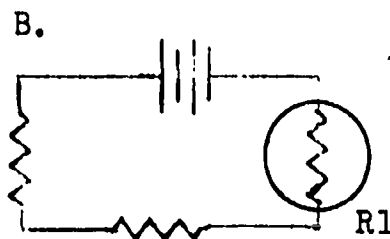
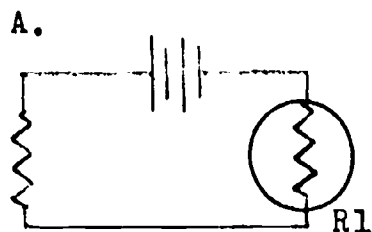

IF ANY OF YOUR ANSWERS IS INCORRECT, GO BACK TO FRAME 21 AND TAKE THE PROGRAMMED SEQUENCE.

IF YOUR ANSWERS ARE CORRECT, YOU MAY TAKE THE PROGRESS CHECK, OR YOU MAY STUDY ANY OF THE OTHER RESOURCES LISTED. IF YOU TAKE THE PROGRESS CHECK AND ANSWER ALL THE QUESTIONS CORRECTLY, GO TO THE NEXT LESSON. IF NOT, STUDY ANY METHOD OF INSTRUCTION YOU WISH UNTIL YOU CAN ANSWER ALL THE QUESTIONS CORRECTLY.

SUMMARY
LESSON 11

Voltage in a Series Circuit

Difference in potential, you will recall, is a difference in the amount of charge between two points. This means that one of the points is more negative (or less positive) than the other.

A potential difference exists at the source where there is a rise in potential, and at a load where there is a voltage drop. The voltage rise at the source is often labeled E_s (for source voltage), E_a (for applied voltage), or E_t (for total or ^sterminal voltage). A ^avoltage drop is often abbreviated simply E , but if there are several voltage drops in the circuit, they may be marked E_{R1} , E_{R2} , etc., so each can be identified.

The total voltage rise in a circuit always equals the total voltage drop in that circuit. In other words, all the energy given to the free electrons by the source is given off as heat as they pass through the load. This is the first rule for series circuit conditions; it is actually an electronic equivalent of the principle of conservation of energy, and is known as Kirchhoff's Voltage Law. Thus:

THE TOTAL VOLTAGE DROP IN A SERIES CIRCUIT WILL ALWAYS EQUAL THE APPLIED VOLTAGE.

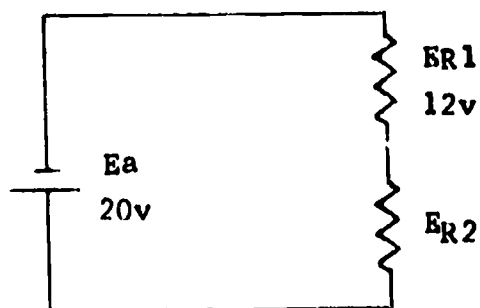

What is the voltage drop (E_{R2}) across $R2$ in this circuit?

(Answer: 8 volts)

No matter how many resistors are in a series circuit, the total applied voltage will be divided among the resistors, and all the voltage will be dropped. The resistance value of each resistor determines what portion of the applied voltage will be dropped by it. The resistor with the greatest resistance will get the largest share of the voltage, the second-largest resistance will get the second-largest voltage, and so on down the line to the smallest resistance. The second rule for series circuit is:

IN A SERIES CIRCUIT, THE LARGEST VOLTAGE DROP WILL TAKE PLACE ACROSS THE LARGEST RESISTANCE.

If you place in series a variable resistor, a fixed resistor, and a source, the voltage drop across the variable resistor will increase

or decrease as the resistance goes up or down, and the fixed resistor will always drop the rest of the applied voltage.

The diagram below illustrates the circuit at three different settings of a variable resistor.

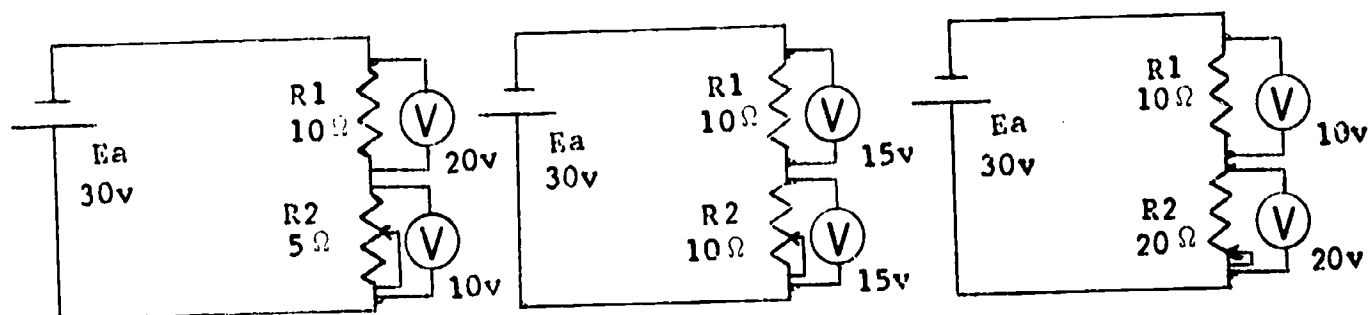

AT THIS POINT, YOU MAY TAKE THE LESSON PROGRESS CHECK, OR YOU MAY STUDY THE LESSON NARRATIVE OR THE PROGRAMMED INSTRUCTION OR BOTH. IF YOU TAKE THE PROGRESS CHECK AND ANSWER ALL OF THE QUESTIONS CORRECTLY, GO TO THE NEXT LESSON. IF NOT, STUDY ANOTHER METHOD OF INSTRUCTION UNTIL YOU CAN ANSWER ALL THE QUESTIONS CORRECTLY.

BASIC ELECTRICITY AND ELECTRONICS
INDIVIDUALIZED LEARNING SYSTEM



MODULE FOUR
LESSON III

Using the Multimeter as a Voltmeter

Study Booklet

BUREAU OF NAVAL PERSONNEL
January 1972

88/89

OVERVIEW
LESSON III

Using the Multimeter as a Voltmeter

In this lesson you will study and learn about the following:

- meter connections
- interpreting the DC voltage scale
- practical measurement of DC voltage
(0-30v)
- measuring DC voltage (30-1000v)
- measuring AC voltage (0-1000v)

Each of the above topics will be discussed in the order listed. As you proceed through this lesson, observe and follow directions carefully.

BEFORE YOU START THIS LESSON, PREVIEW THE LIST OF STUDY RESOURCES ON THE NEXT PAGE.

LIST OF STUDY RESOURCES
LESSON III

Using the Multimeter as a Voltmeter

To learn the material in this lesson, you have the option of choosing, according to your experience and preferences, any or all of the following:

STUDY BOOKLET:

Lesson Narrative
Programmed Instruction
Lesson Summary

ENRICHMENT MATERIAL:

NAVPERS 93400A-1a "Basic Electricity, Direct Current."
Fundamentals of Electronics. Bureau of Naval Personnel.
Washington, D.C.: U.S. Government Printing Office, 1965.

AUDIO-VISUAL:

Sound/Slide Presentation - "Measuring Voltage With a Multimeter."

YOU MAY NOW STUDY ANY OR ALL OF THE RESOURCES LISTED ABOVE. YOU MAY TAKE THE PROGRESS CHECK AT ANY TIME.

NARRATIVE
LESSON III

Using the Multimeter as a Voltmeter

You have learned to use the multimeter to measure resistance and direct current. We are now going to use it to take DC and AC voltage readings. The settings and connections to use the multimeter as a voltmeter will be different than the ones used when using it as an ammeter or ohmmeter.

A Word of Caution: Always connect a voltmeter in parallel (across) the potential difference to be measured, never in series. Recall that this is exactly opposite to the way we connect an ammeter.

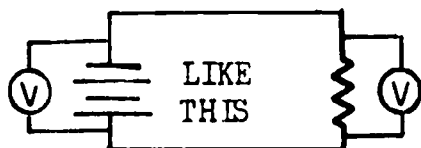

A Little on Voltmeter Theory

If we think in terms of current (the flow of electrons) being the only electrical quantity that moves within a circuit, then all meters must operate on current flow. In other words, some amount of current causes all meter pointers to deflect. In the case of a voltmeter, it operates on a very small amount of current but the meter face is calibrated in volts. When a voltage is applied to the test leads, a current flows from the negative jack through the function switch to the meter movement, through the meter movement to the proper multiplier resistor, as selected by the range switch, and then through the range switch to the positive jack of the meter. The range switch selects the proper multiplier resistor for the range of voltage being measured.

The function of the multiplier resistor is to limit the current to a value that will not damage the meter movement.

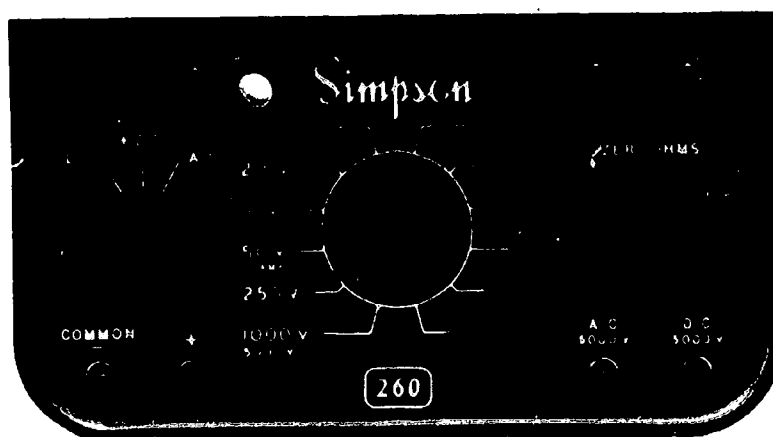

Interpreting the DC Voltage Scale

You will use the black arc labeled DC (second from the top) for all DC voltage measurements. Recall that this is the same arc (scale) we used to read current.

The three rows of numbers directly under the DC arc will be used to measure values of voltage. The row used will depend on the position of the range selector. If the range switch is set on 2.5 v, simply put an imaginary decimal point before the last two digits on the 250 row. You are actually dividing by 100. If the range switch is set on 10, you read the 10 v scale directly; if set at 50, you read the 50 v scale directly. When the setting is 250, you read the 250 v scale directly. If the range switch is in the 1000 v position, use the 0-10 scale and add two zeros to the indicated value. Here you are multiplying by 100.

(See illustration on next page.)

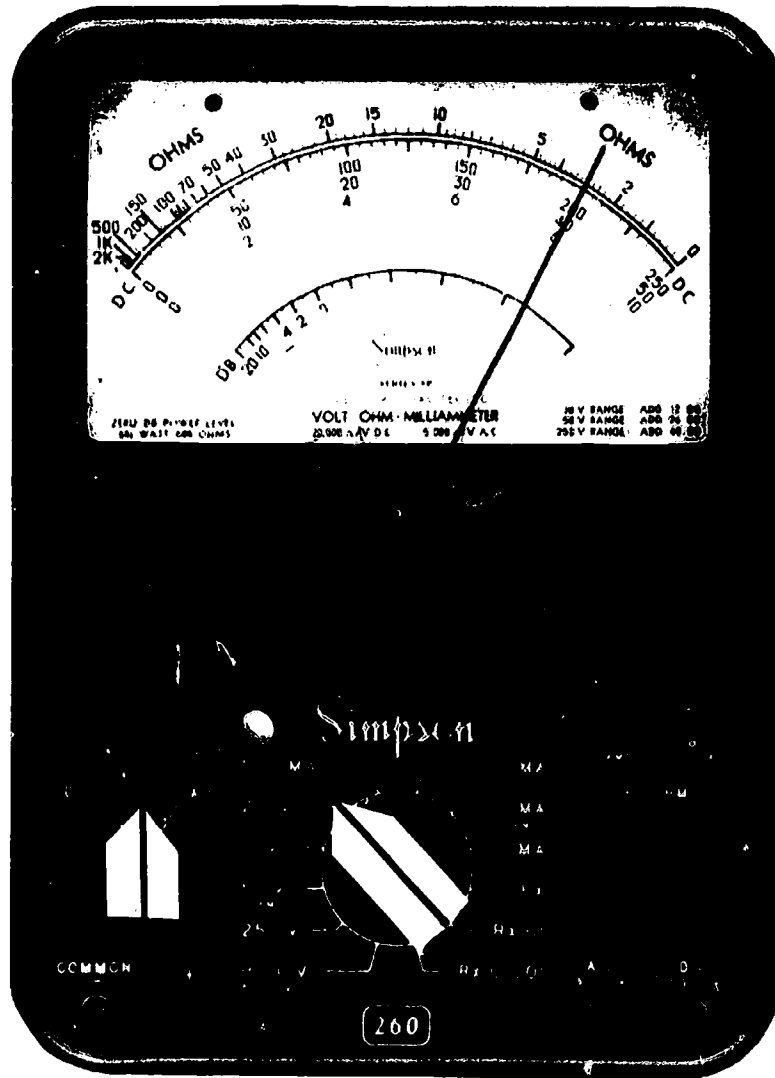

In this illustration, the meter reads 2 volts.

Measuring DC Voltage (0-30 Volts)

- Using Practice Board 0-1, a 10 Ω resistor, and four dry cells, construct a series circuit as shown below.

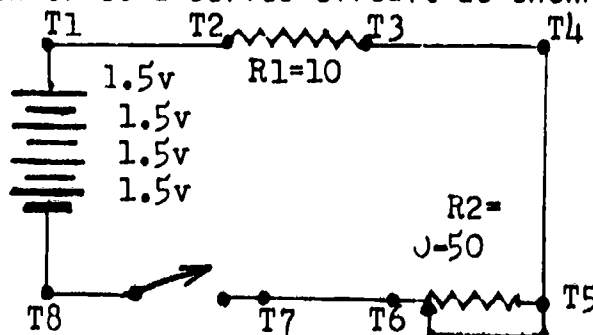

NOTE: Before you wire the variable resistor into the circuit, adjust it to 0 ohms. To do this, set the multimeter up as an ohmmeter, zero it, connect a test lead to each wire of the rheostat, and turn the resistor knob until the meter registers 0. Connect R2 into the circuit.

2. Set up multimeter as voltmeter to read 0-50 volts.

(You know the source voltage is 6 v.)

- a. Set function switch to +DC.
- b. Plug black test lead into common (-) jack and red test lead into (+) jack.
- c. Set the range selector in the 10 v position.

NOTE: When in doubt about the amount of voltage, always use the highest voltage range (1000 v).

- d. Observe the correct polarity and place meter leads across T1 and T8 and measure applied voltage. If pointer deflects to left of 0, the actual circuit polarity is opposite to that which was anticipated. Place function selector in the -DC position to correct the polarity as applied to the meter.

3. Energize the circuit and place meter range switch in the 10 v position.

4. Read voltage on black DC arc. Record _____.
-

You read approximately 6 v, as you would expect, because you are reading the difference of potential across the source, or the voltage rise.

5. To read the voltage drop across R2, connect meter probes across T6 and T5.

6. Read and record _____.
-

You should have read 0, because the resistor is set at 0 and there is no voltage across it. It is acting like a straight piece of wire in the circuit and has no difference in potential.

7. Place probes across T2 and T3 to read the voltage drop across R1. Remember to observe polarity.

8. Record _____.
-

The voltage drop across R_1 , which we designate as E_{R_1} , is approximately 6 v is the amount of voltage applied to the circuit. All of the applied voltage is being dropped across R_1 because we consider it as the only opposition to current in the circuit.

Now let's see what happens when we add resistance to the circuit by varying R_2 .

1. Connect the probe clips across R_2 .
2. Slowly turn the knob on the variable resistor to increase resistance.
3. Observe the meter.
4. Turn the knob until R_2 is at full resistance (as far as knob will turn).
5. What is E_{R_2} ? _____.

You read that E_{R_2} is approximately 5 v when R_2 is at its maximum resistance value and is in series with R_1 . As R_2 is now about 50 Ω and R_1 is 10 Ω , this demonstrates that the greatest voltage drop takes place across the greatest resistance.

6. Leaving R_2 at maximum 50 Ω , connect probes across R_1 .
7. E_{R_1} equals _____.

E_{R_1} then is approximately 1 volt, demonstrating that the sum of the voltage drop equals the applied voltage. Note that these values (5 v and 1 v) are not exact because we need to allow for meter and circuit tolerances.

8. Reconnect probes across R_2 and vary resistance again until you read approximately 3 v on the meter.
9. Then read E_{R_1} to see if you also read approximately 3 v there.

You have observed that as the value of R_2 increases, E_{R_2} increases and E_{R_1} decreases. The reverse is also true. As R_2 decreases, E_{R_2} decreases and E_{R_1} increases so that the sum of the voltage drops equals the applied voltage.

Now we are going to measure voltage at one point in your power supply. Measure only as instructed; otherwise you will be disregarding safety precautions and you might encounter high voltages.

Your power supply has an AC source, so you will be measuring an AC voltage for the first time.

WARNING: Be extremely careful. Do not touch the meter or test leads while power is on in the circuit being measured. Be sure power is off when connecting and disconnecting test leads.

1. Be sure the switch in your power supply is open.
 2. Set up the meter to read 0-1000 volts AC.
 - a. Set function switch to AC.
 - b. We will be reading a voltage between 20 v and 30 v, so place the range switch in the 50 v position.
 - c. Plug leads as usual.
 3. As we are measuring AC, polarity need not be observed. Connect leads across T1 and T8 (nowhere else).
 4. Plug power supply into wall outlet and energize by closing the switch.
 5. Record meter reading. _____ Read the red arc marked AC and use the black figures immediately above the arc that correlates with the position of the range switch. We are in the 50 v position so we use the 0-50 figures. You should be reading approximately 30 v AC.
 6. De-energize circuit and remove test leads.
-

Measuring DC Voltage (30-1000 Volts)

You will not actually measure voltages above 30 volts while in this school because of safety considerations. However, you should understand how to set up the meter to do so. The important thing to remember here is that you will not touch the meter leads or meter while it is connected to an energized circuit if the voltage to be measured is above 30 volts.

You have already learned the initial steps in setting up the meter.

You also know how to set the range in any of the five positions. When in doubt, use the highest voltage range. Observe the meter reading. If the voltage is within a lower range, the switch may be set for the lower range to obtain a more accurate reading.

Note: De-energize the circuit prior to turning range switch.

When you energize the circuit to be tested, if the pointer deflects to the left of 0, the circuit polarity is opposite the anticipated polarity. Turn the circuit power off. Set the function switch at -DC, and turn the power on. This will correct the polarity as applied to the meter. Read the voltage on the black arc marked DC. Turn the circuit power off before disconnecting leads.

Measuring AC Voltage (30-1000 volts)

Warning: Here again if the voltage to be measured is above 30 volts, do not touch meter or its leads while they are connected to the energized circuit. The circuit must be de-energized when making meter connections.

AT THIS POINT, YOU MAY TAKE THE PROGRESS CHECK, OR YOU MAY STUDY ANY OF THE OTHER RESOURCES LISTED. IF YOU TAKE THE PROGRESS CHECK AND ANSWER ALL OF THE QUESTIONS CORRECTLY, YOU HAVE MASTERED THE MATERIAL AND ARE READY TO TAKE THE MODULE TEST. SEE YOUR INSTRUCTOR.

IF YOU DECIDE NOT TO TAKE THE PROGRESS CHECK AT THIS TIME, OR IF YOU MISSED ONE OR MORE QUESTIONS, STUDY ANY METHOD OF INSTRUCTION YOU WISH UNTIL YOU HAVE ANSWERED ALL THE PROGRESS CHECK QUESTIONS CORRECTLY. THEN SEE YOUR INSTRUCTOR AND ASK TO TAKE THE MODULE TEST.

PROGRAMMED INSTRUCTION
LESSON III

Using the Multimeter as a Voltmeter

TEST FRAMES ARE 7, 14, 31, 34, 43, 44, 52, AND 56. AS BEFORE, GO FIRST TO TEST FRAME 7 AND SEE IF YOU CAN ANSWER ALL THE QUESTIONS THERE. FOLLOW THE DIRECTIONS GIVEN AFTER THE TEST FRAME.

1. Recall that voltage is measurable only where there is a difference of potential. Between what points in the circuit can voltage be measured?

- a. A and B
- b. C and D
- c. B and C
- d. A and F
- e. D and E

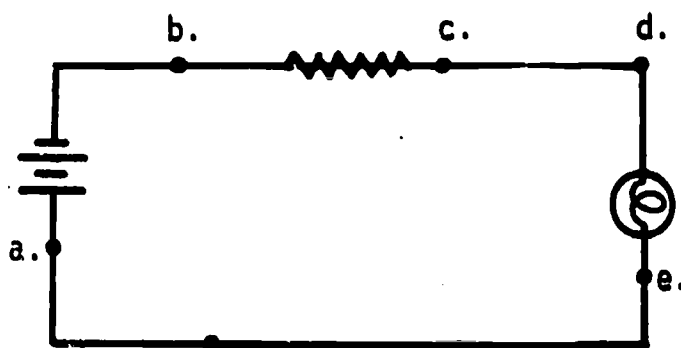

(a. A and B; c. B and C; e. D and E)

2. When using the multimeter as a voltmeter for measuring voltage, it must always be connected in parallel with the potential difference to be measured.

Which meters are correctly connected for measuring voltage?

- a. Meter #1
- b. Meter #2
- c. Meter #3
- d. Meter #4
- e. Meter #5

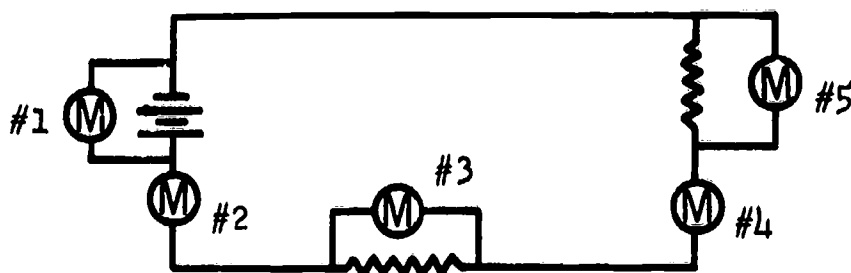

(a. Meter #1; c. Meter #3; e. Meter #5)

3. The Simpson 260-5P multimeter is capable of measuring either AC or DC voltages.

Which control on the multimeter determines whether AC or DC voltage values are to be measured?

- a. 0 ohms
- b. function switch.

(b) function switch

4. When measuring DC voltage, polarity must be observed.

The negative probe of the meter must be connected to a point of negative polarity and the positive probe of the meter to a point of positive polarity.

Which schematic shows the multimeter correctly installed for DC voltage measurements?

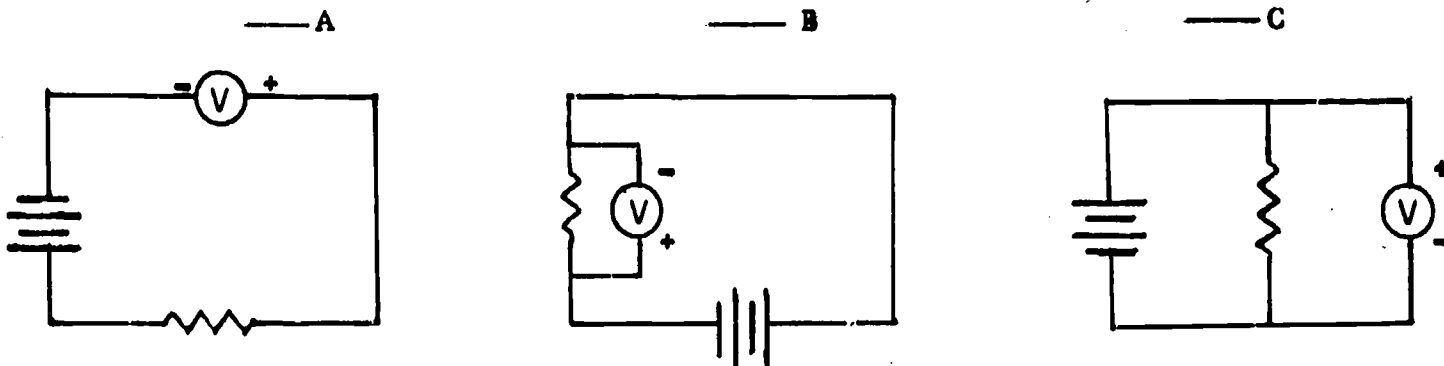

(C)

5. Which voltmeter is correctly installed for measuring DC voltage?

- a. Voltmeter #1
- b. Voltmeter #2
- c. Voltmeter #3

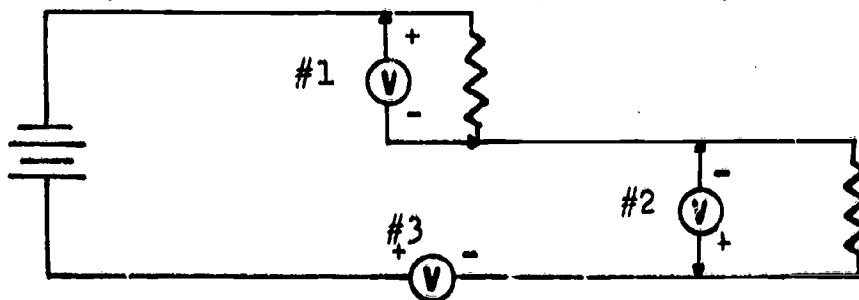

(b) Voltmeter #2

6. When used to measure AC voltage, meter polarity does not have to be observed. Which schematic shows the meter correctly installed for AC voltage measurements?

___ A

___ B

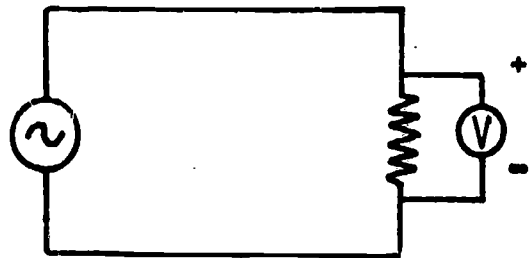
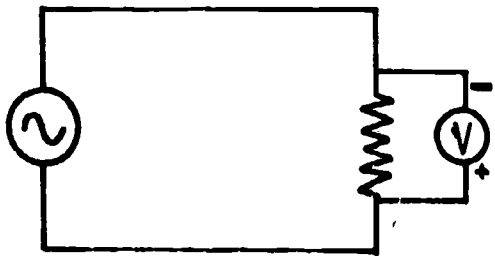

(A, B - both are correct)

7. Match:

___ 1.

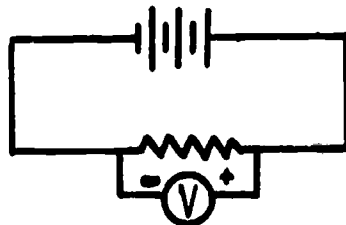

a. AC voltage meter connection

___ 2.

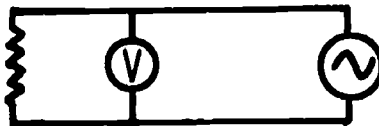

b. DC voltage meter connection

___ 3.

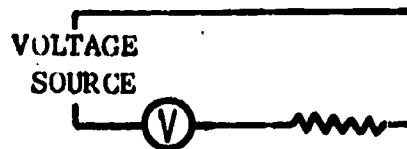

c. incorrect voltmeter connection (AC & DC)

___ 4.



(THIS IS A TEST FRAME. COMPARE YOUR ANSWERS WITH THE CORRECT ANSWERS GIVEN AT THE TOP OF THE NEXT PAGE.)

ANSWERS - TEST FRAME 7

1. b
2. a
3. c
4. a

IF ALL YOUR ANSWERS MATCH THE CORRECT ANSWERS, YOU MAY GO ON TO TEST FRAME 14. OTHERWISE, GO BACK TO FRAME 1 AND TAKE THE PROGRAMMED SEQUENCE BEFORE TAKING TEST FRAME 7 AGAIN.

8. The illustration below shows the meter scales and controls that are used with the voltmeter section of the Simpson 260-5P multimeter. Compare the illustration with the meter provided, then match the letters to the parts of the multimeter.

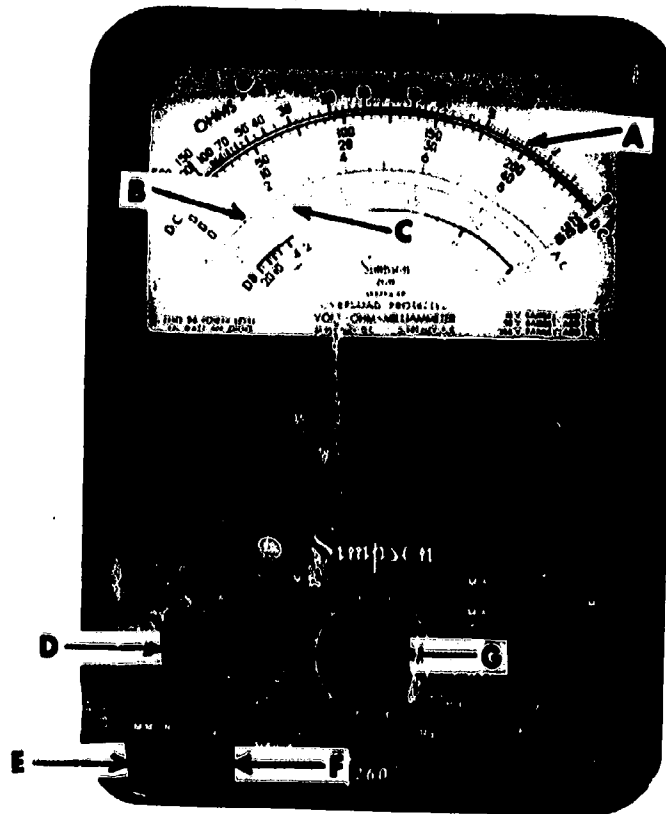

- | | |
|------------------------|-------------------------|
| ___ 1. function switch | ___ 5. DC voltage scale |
| ___ 2. (+) test jack | ___ 6. AC voltage scale |
| ___ 3. range switch | ___ 7. 2.5v AC scale |
| ___ 4. common (-) jack | |

(1. d; 2. f; 3. g; 4. e; 5. a; 6. b; 7. c)

- 9. When measuring DC voltage, the function switch must be in the +DC or -DC position (depending on the polarity of voltage being measured).

What function switch setting(s) can be used when measuring direct current voltage?

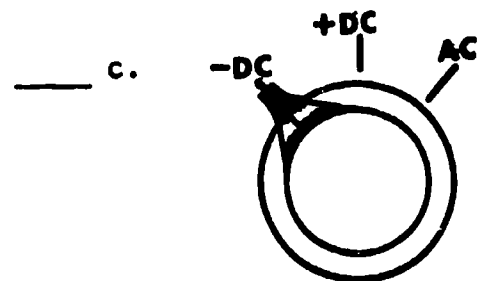
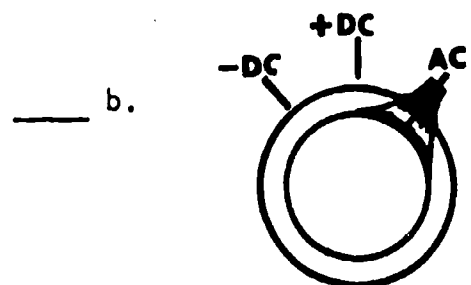
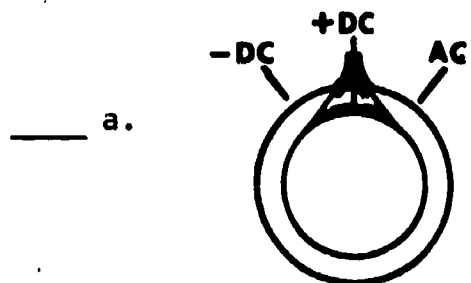

 (a, c)

- 10. To measure direct current, the function switch must be in the _____ or the _____ positions.

 (+DC, -DC depending on the polarity)

11. When setting up the multimeter to read DC voltage, the function switch is normally placed in the +DC position. Remember DC voltage measurements require that polarity be observed.

Which drawing shows the multimeter correctly connected for measuring DC voltage?

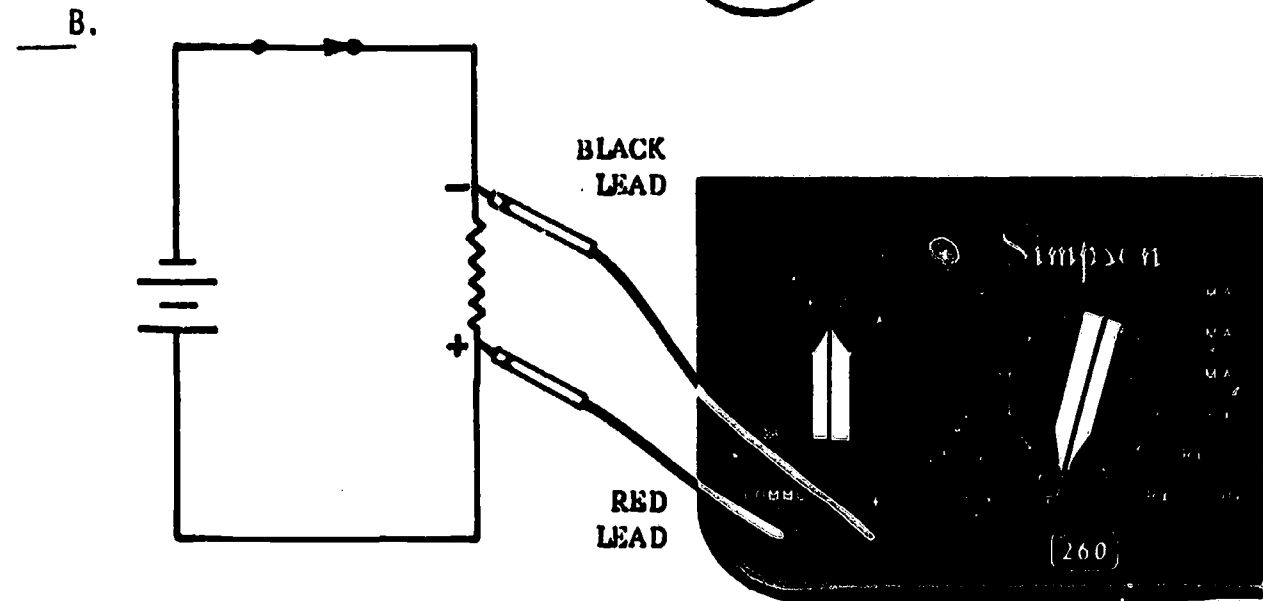
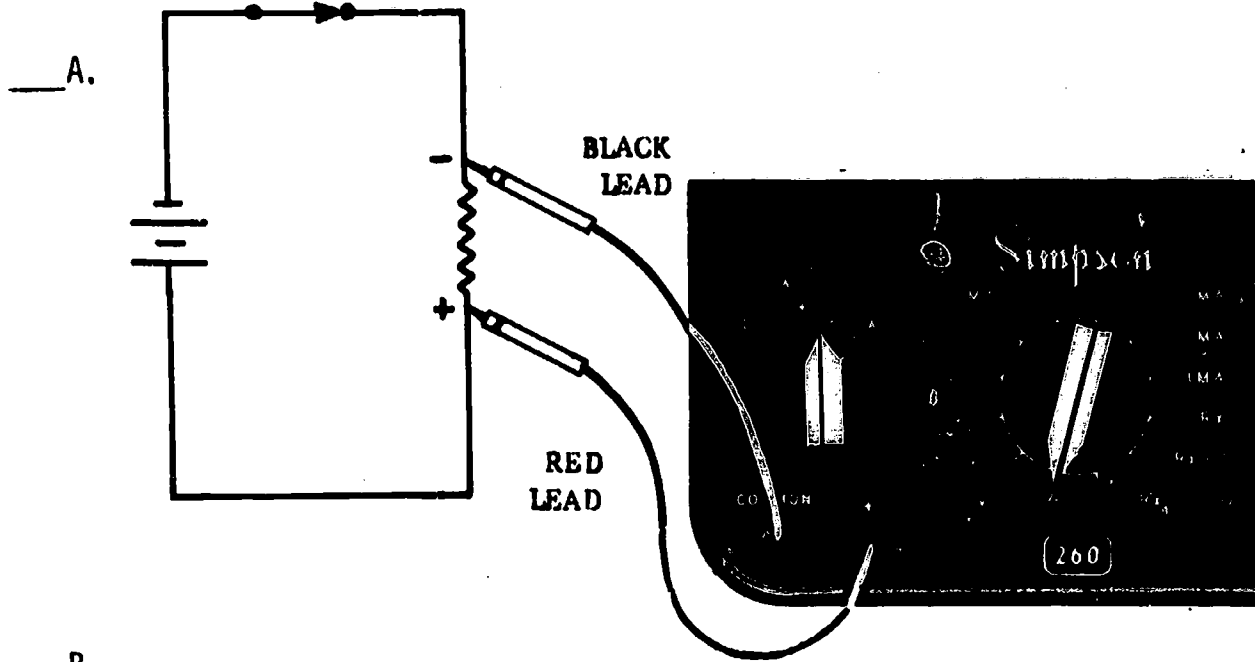

(A)

12. The pointer of the multimeter when not measuring current or voltage, should rest at the "0" position. When the meter is properly connected to measure current or voltage, the proper polarity must be observed. The pointer will then move to the right.

Which pointer position indicates proper polarity of the meter connection?

A.

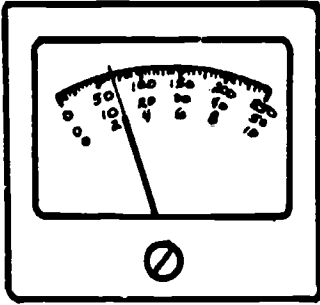

B.

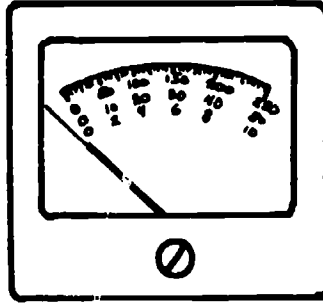

C.

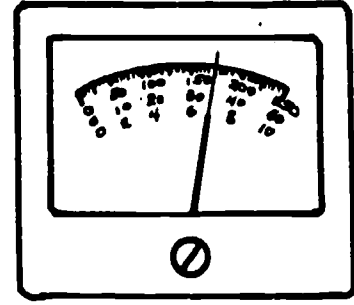

(A, C)

13. If for some reason the meter is connected improperly, the function switch can be used to change the polarity of the meter without removing the meter leads from the circuit under test. The illustration below shows an improper meter connection. Check the function switch position you would use to correct the meter connection.

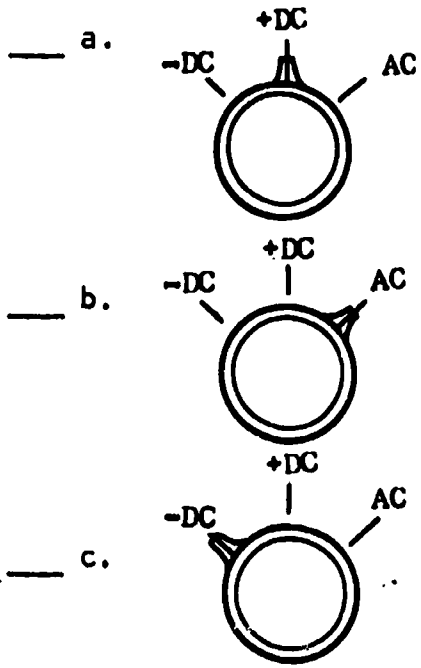
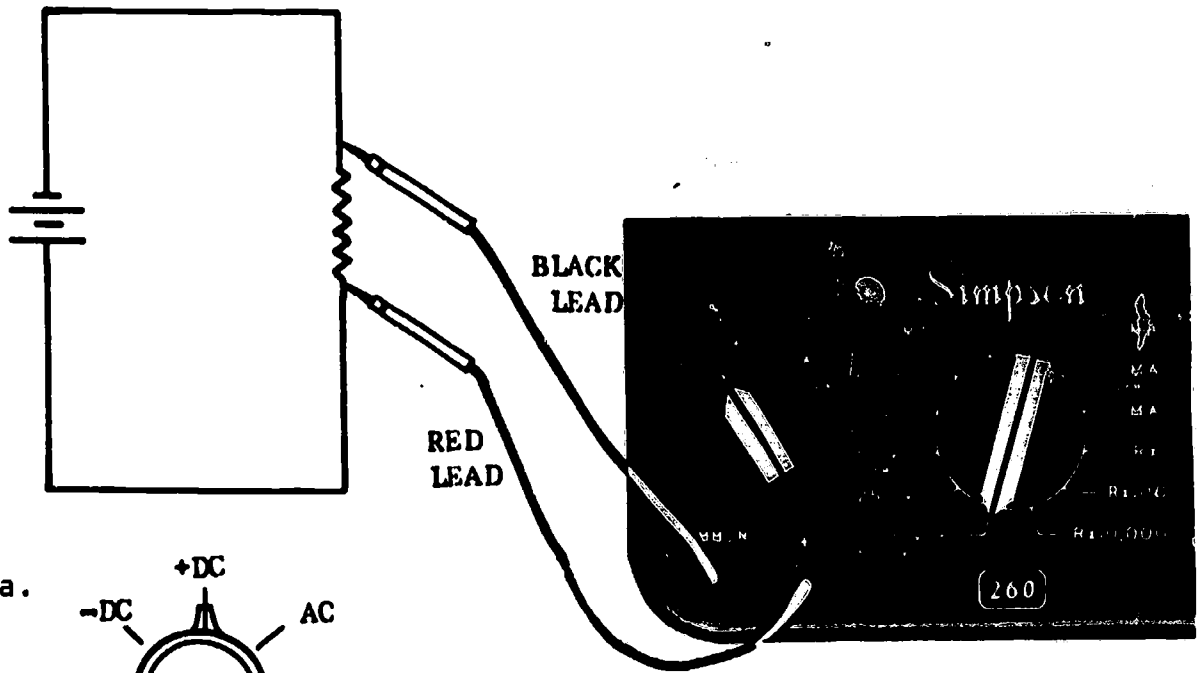

(a)

14. Check the statements that are true.

- a. When measuring voltage, the function switch must always be in the +DC position.
 - b. When reading DC voltage, polarity must be observed.
 - c. When measuring DC voltage, correct meter connection will cause pointer deflection to the left of zero.
 - d. Meter polarity can be changed by moving the function switch to either +DC or -DC.
 - e. Meter polarity can only be changed by removing the test leads from the circuit and reversing them.
-
-

(THIS IS A TEST FRAME. COMPARE YOUR ANSWERS WITH THE CORRECT ANSWERS GIVEN AT THE TOP OF THE NEXT PAGE.)

ANSWERS - TEST FRAME 14

- b. When reading DC voltage, polarity must be observed.
- d. Meter polarity can be changed by moving the function switch to either +DC or -DC.

IF ALL YOUR ANSWERS MATCH THE CORRECT ANSWERS, YOU MAY GO ON TO TEST FRAME 31. OTHERWISE, GO BACK TO FRAME 8 AND TAKE THE PROGRAMMED SEQUENCE BEFORE TAKING TEST FRAME 14 AGAIN.

15. Look at the range switch positions on your multimeter, then label the five voltage positions on the drawing below just as they are marker on your meter.

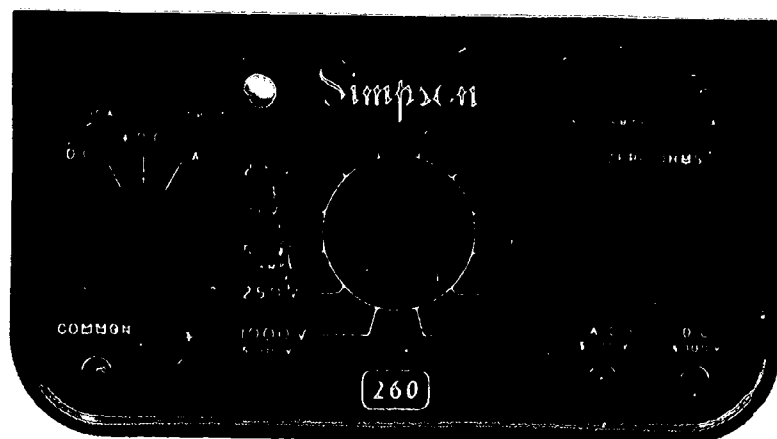
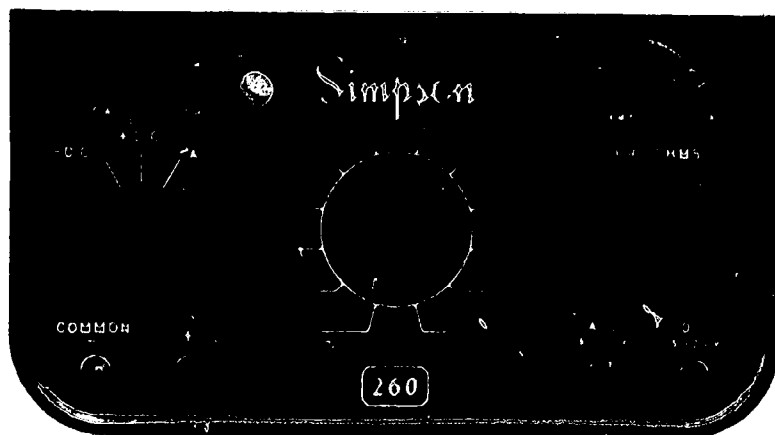

16. Each voltage range-switch marking represents the maximum voltage that the multimeter is capable of measuring when in that position. For example if the range switch is set to 50 v, this means that the voltage range is 0-50 v; if the range switch is set to 10 v, the voltage range would be 0-10 v.

What would the voltage range be if the range switch were set to 250 v?

- a. 250-1000 v
- b. 0-250 v
- c. 10-250 v

(b) 0-250 v

17. Look at the voltage range switch positions again, then list the voltage ranges the meter is designed to measure. (Any order.)

- a. _____
- b. _____
- c. _____
- d. _____
- e. _____

(0-2.5 v; 0-10 v; 0-50 v; 0-250 v; 0-1000 v/5000 v)

18. The meter scale used for measuring DC voltage is the black arc that is labeled DC (second from top). Locate the DC scale on your multimeter, then check the arrow that points to the DC scale in the illustration.

PAT. NO. 2,433,165 MADE IN U.S.A. BY SIMPSON ELECTRIC CO CHICAGO, ILL.

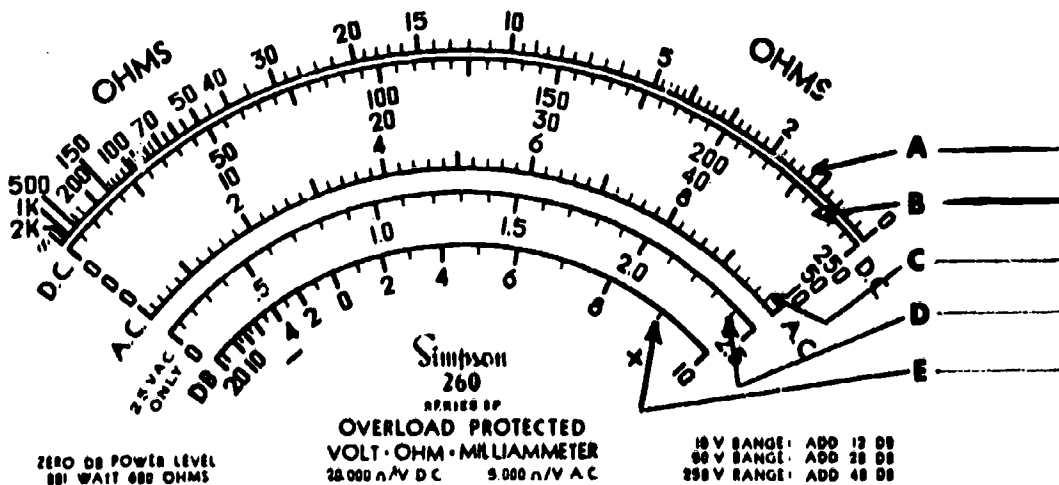

(b)

19. Look at the DC scale on your multimeter again. Notice that there are three rows of numbers under the black arc calibrated 0-250, 0-50, and 0-10. All three of these meter scales are used for DC voltage measurements. The position of the range switch (2.5 v, 10 v, 50 v, 250 v, 1000/5000 v) will determine which DC meter scale to use.

Which diagram correctly identifies the numbers used for measuring DC voltage?

 A.

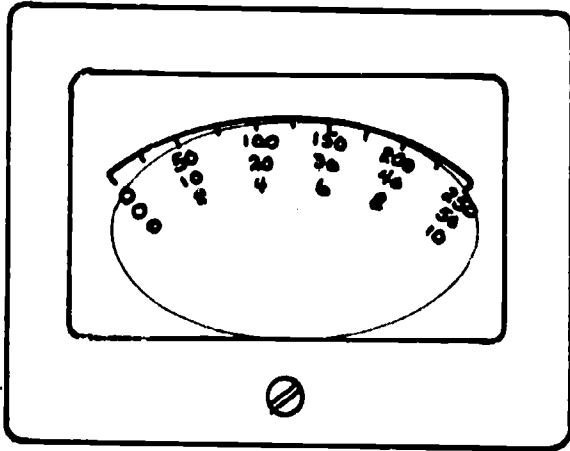

 B.

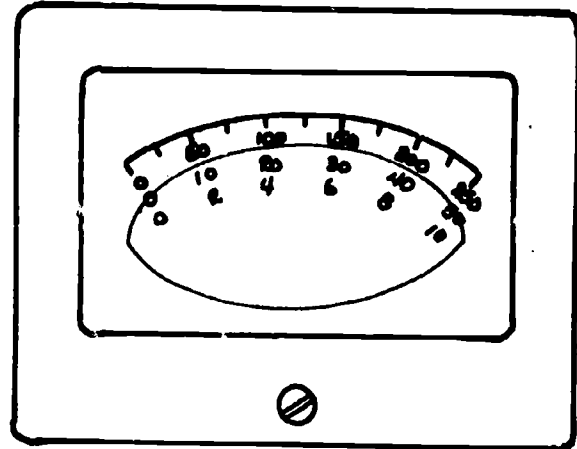

(A)

20. When the range switch is in the 2.5 v position, use the 0-250 DC scale and divide the indicated value by 100. What would the voltage reading be for the illustration?

- a. 1.25 volts
- b. 12.5 volts
- c. 25 volts
- d. 250 volts

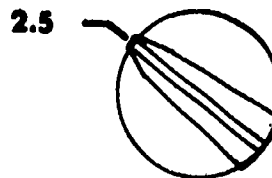
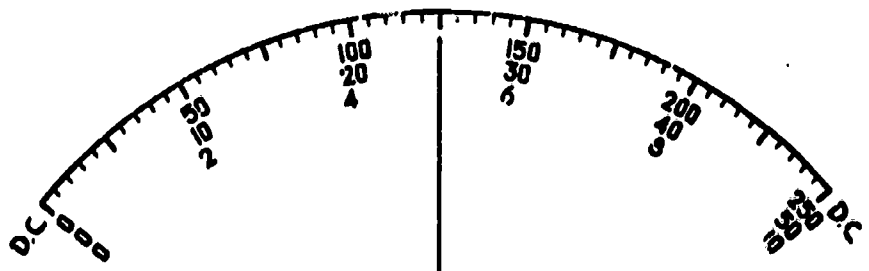

(a) 1.25 v

21. Which illustration indicates a voltage value of 0.5 volts on a Simpson 260 meter.

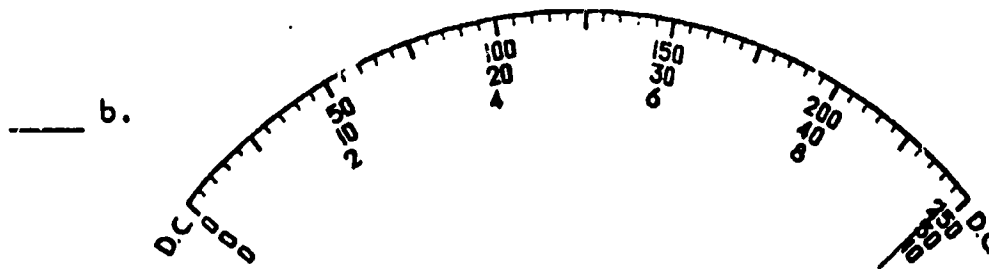
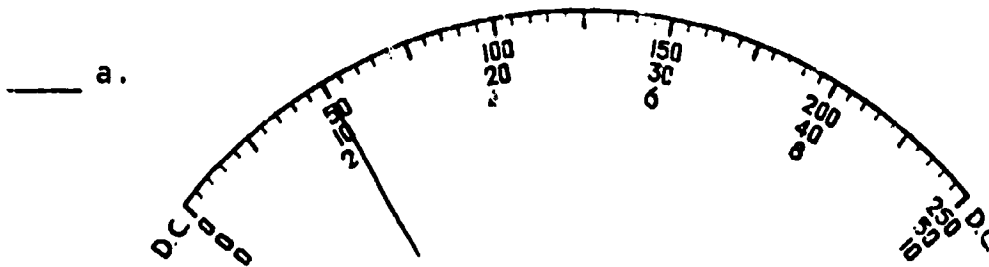

(a)

22. What is the voltage indicated? _____ v DC

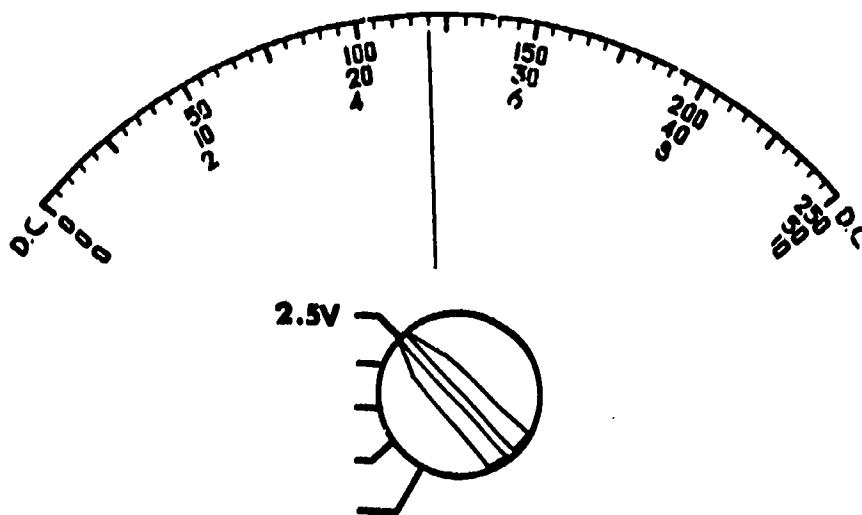

(1.2 v DC)

23. If the range switch is in the 1000 v position, use the 0-10 DC scale and multiply by 100.

What would the voltage reading be for the illustration?

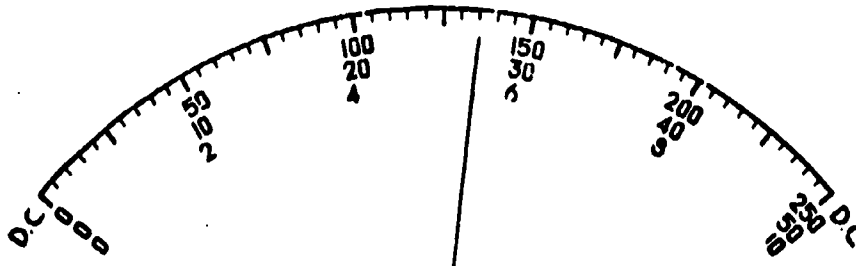

The voltage indicated is _____ v DC

(540 v DC)

24. Which illustration could indicate a voltage value of 460 volts on the Simpson 260?

_____ a.

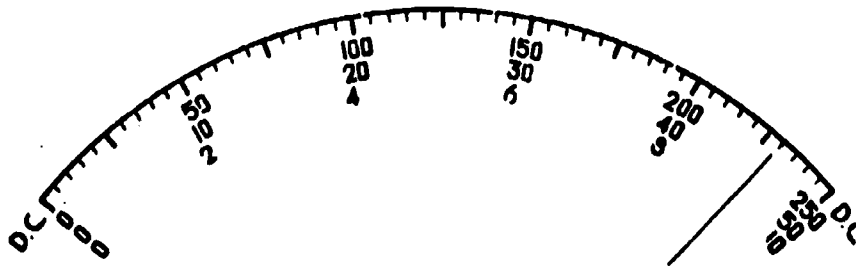

_____ b.

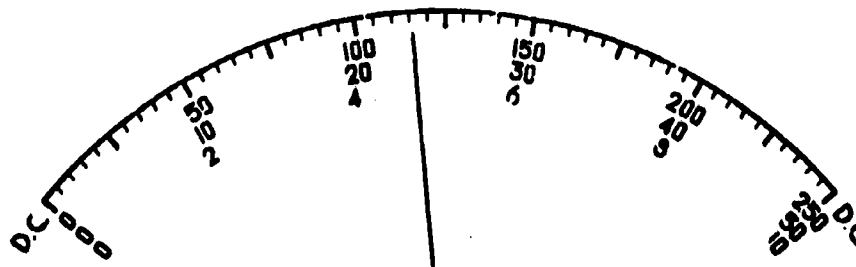

(b)

25. What is the voltage indicated? _____ v DC
 (Meter jacks for 0-1000 v are in use.)

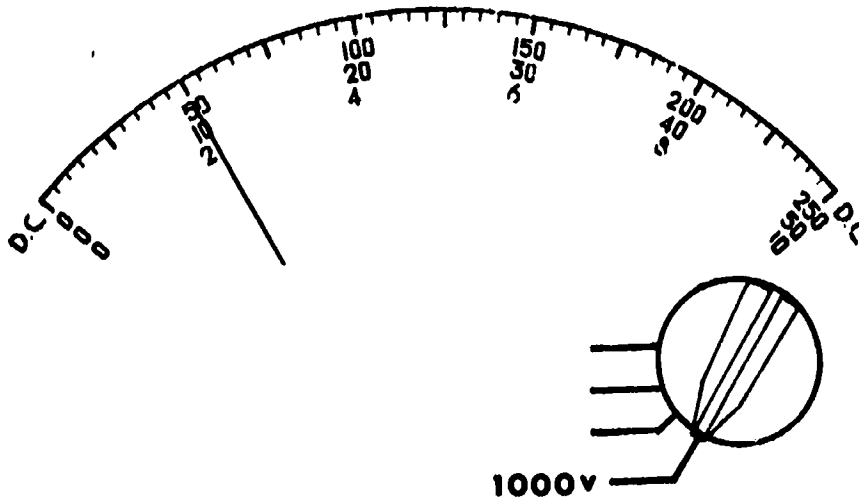

 (200 v DC)

26. Match.

<u>Meter Scale</u>	<u>Range-switch Setting</u>
_____ 1. 0-10 x 100	_____ a. 2.5 v
_____ 2. 0-250 ÷ 100	_____ b. 1000 v

 (1. b; 2. a)

27. If the range switch is set on the 10 v position, voltage is read directly on the 0-10 DC scale.

What would the voltage reading be for the illustration?

- _____ a. 46 v DC
- _____ b. 230 v DC
- _____ c. 5 v DC
- _____ d. 4.6 v DC

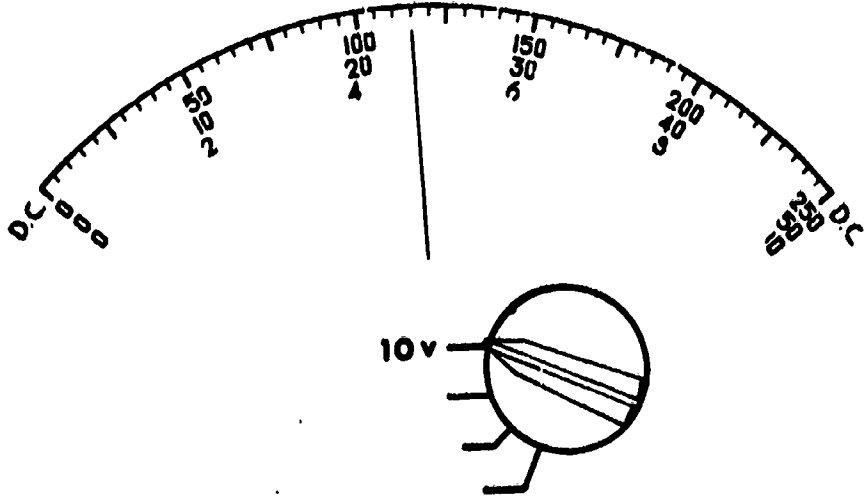

 (d) 4.6 v DC

28. If the range switch is set on the 50 v position, voltage is read directly on the 0-50 DC scale.

What would the voltage reading be for the illustration?

- a. 130 v DC
- b. 26 v DC
- c. 5.2 v DC
- d. 35 v DC

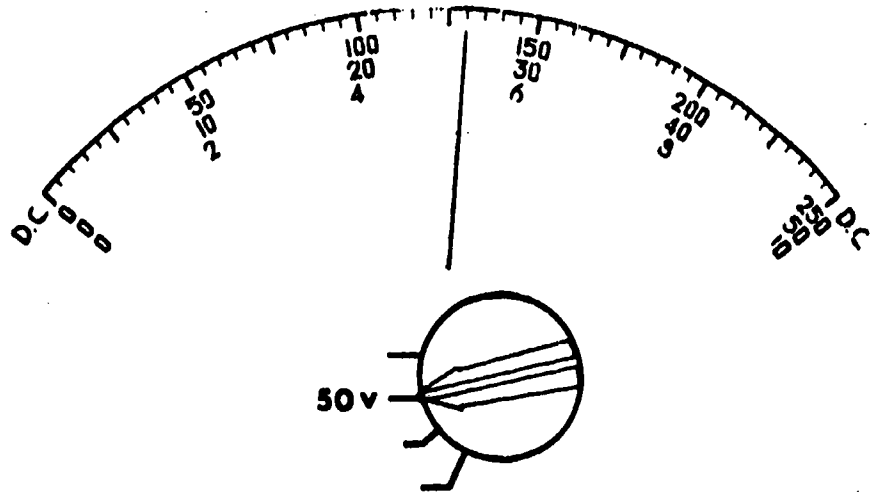

(b) 26 v DC

29. If the range switch is set on the 250 v position, voltage is read directly on the 0-250 DC scale.

What would be the voltage reading for the illustration.

- a. 135 v DC
- b. 5.4 v DC
- c. 270 v DC
- d. 54 v DC

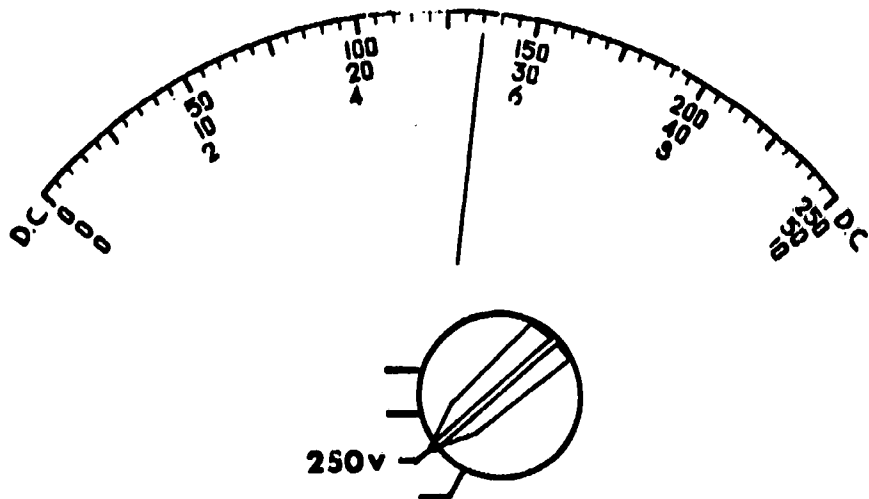

(a) 135 v DC

30. Match the meter DC scale to the range switch position. Meter leads are connected to common (-) and (+) jacks in every case.

<u>Range Switch Position</u>	<u>Meter DC Scale</u>
___ 1. 2.5 v	a. 0-50
___ 2. 10 v	b. 0-10
___ 3. 50 v	c. 0-250
___ 4. 250 v	
___ 5. 1000/5000 v	

(1. c; 2. b; 3. a; 4. c; 5. b/a)

31. Interpret the meter DC scale below by matching the indicated voltage to the range switch position.

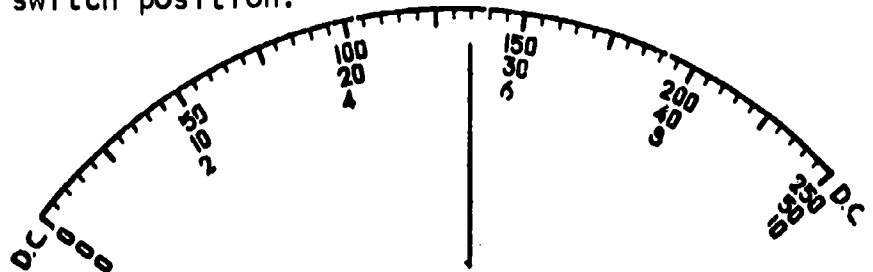

<u>Range Switch Position</u>	<u>DC Voltage</u>
___ 1. 10 v	a. 540 volts
___ 2. 50 v	b. 135 volts
___ 3. 2.5 v	c. 27 volts
___ 4. 250 v	d. 1.35 volts
___ 5. 1000 v	e. 5.4 volts

(THIS IS A TEST FRAME. COMPARE YOUR ANSWERS WITH THE CORRECT ANSWERS GIVEN ON THE TOP OF THE NEXT PAGE.)

ANSWERS - TEST FRAME 31

1. e
 2. c
 3. d
 4. b
 5. a
-

IF ALL YOUR ANSWERS MATCH THE CORRECT ANSWERS, YOU MAY GO ON TO TEST FRAME 34. OTHERWISE, GO BACK TO FRAME 15 AND TAKE THE PROGRAMMED SEQUENCE BEFORE TAKING TEST FRAME 31 AGAIN.

32. When using the multimeter to read DC voltage, the common (-) test jack and the (+) test jack are used.

Using the illustration below, locate on your multimeter the common (-) jack and (+) jack.



(Go to next frame.)

33. On the illustration below, check the arrows which point to the jacks used when making DC voltage measurements.

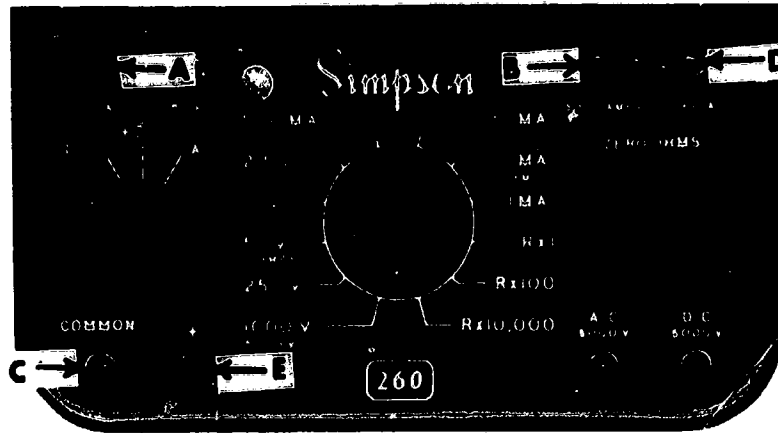

(c, e)

34. Check the controls, jacks and scales that are used for measuring DC voltage, between 0-1000V.

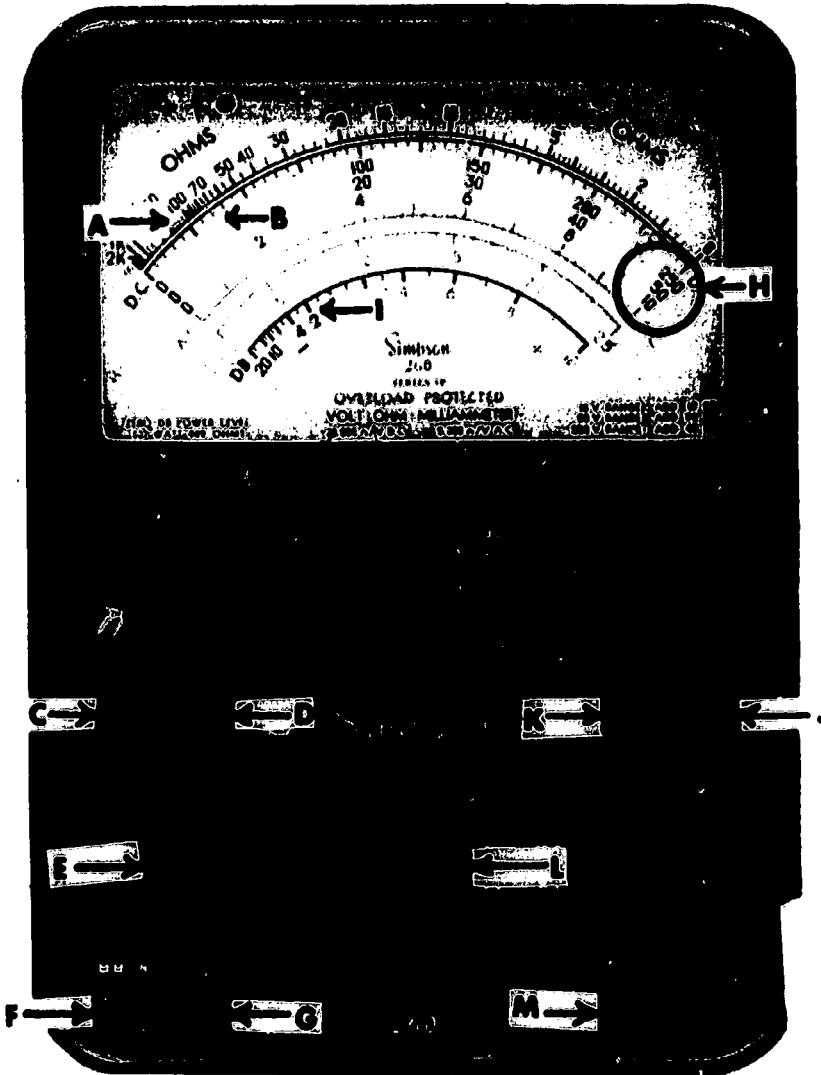

(THIS IS A TEST FRAME. COMPARE YOUR ANSWERS WITH THE CORRECT ANSWERS GIVEN AT THE TOP OF THE NEXT PAGE.)

ANSWERS - TEST FRAME 34

b, e, f, g, h, l

IF ALL YOUR ANSWERS MATCH THE CORRECT ANSWERS, YOU MAY GO ON TO TEST FRAME 43. OTHERWISE, GO BACK TO FRAME 32 AND TAKE THE PROGRAMMED SEQUENCE BEFORE TAKING TEST FRAME 34 AGAIN.

35. Using practice board 0-1 and components available in the resource center, construct a series circuit as shown below.

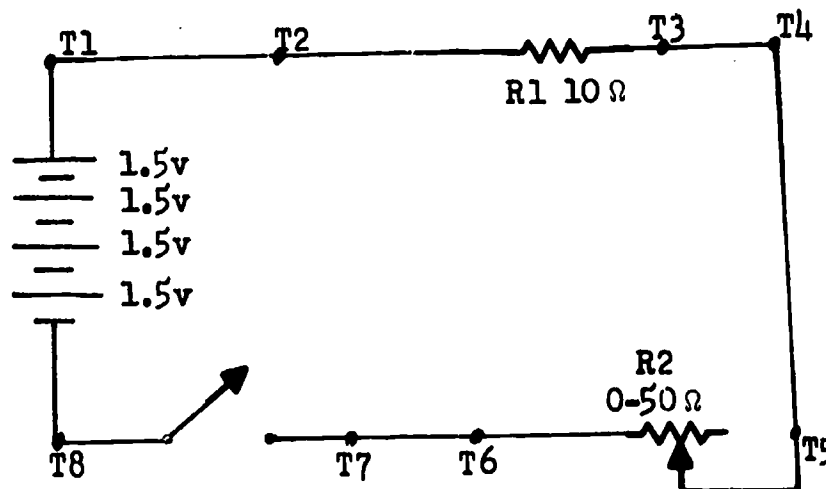

NOTE: Before you wire the rheostat (R2) into the circuit, set it at 0 ohms. To do this, set up the multimeter as an ohmmeter, zero it, connect a test lead to each wire of the rheostat and turn the knob until the meter registers 0. Connect R2 into the circuit. If a review of the ohmmeter function of the multimeter is needed, refer to Module Three - Lesson IV.

36. Listed below are the proper steps for setting up the multi-meter for measuring DC voltage.
1. Set the function switch at +DC.
 2. Plug the black test lead into the common (-) jack and the red test lead into the (+) jack.
 3. Set the range switch at the 1000/5000 v position.
(Always start with the highest voltage range settings and then reduce as necessary to obtain a reading near midscale.)

Following the steps listed above, set up your multimeter, then check your meter set up against this illustration.

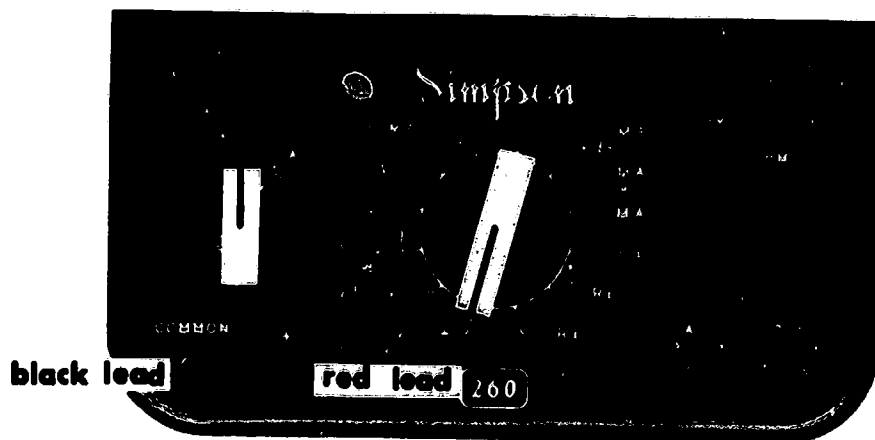

(Go to next frame.)

37. Energize the series circuit you have constructed, and observing correct polarity (red test lead to positive side of the source and black test lead to negative side), place the meter leads across T1 and T8.

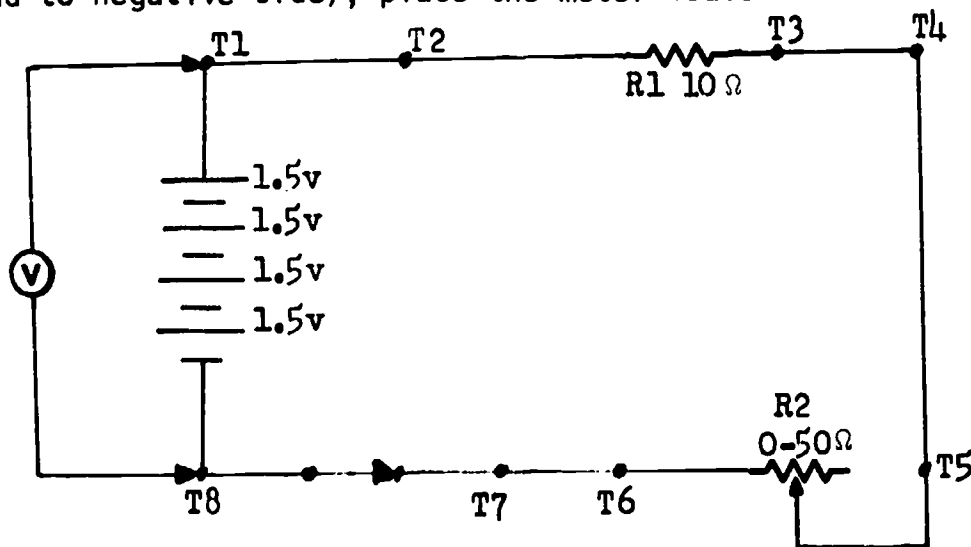

If the meter pointer deflects to left of "0", the polarity is opposite to that which was anticipated. Place the function switch in the -DC position. This will correct the polarity as applied to the meter.

(Go to next frame)

38. Decrease the range switch setting until you get a reading near midscale. Be careful not to turn to a range setting lower than the voltage present. At what range-switch position do you get the best midscale reading?

(10 v position)

39. Read the voltage on the black DC 0-10 scale. What is the value of the applied voltage (E_a) in the circuit? _____ volts.

($E_a = 6$ v approximate)

40. Place the test probes across T5 and T6. What is the voltage drop across R2 (variable resistor)? _____

($E_{R2} = 0$ volts) Because the resistor is set at 0, there will be no voltage dropped across it. The resistor is acting like a piece of wire in the circuit and has no difference in potential.

41. Next place your probes across R1 (between T2 and T3). What is the voltage drop across R1? _____ v.

($E_{R1} = 6$ v approximate) Recall that the sum of the voltage drops must equal the applied voltage (E_a); and in a series circuit, the greatest voltage drop takes place across the greatest resistance. In this case, $E_{R1} (6 \text{ v}) + E_{R2} (0 \text{ v}) = E_a (6 \text{ v})$.

42. For your next measurement, connect the probe clips across R1 and increase the resistance of R2 by turning the knob. Observe the meter. The voltage drop across R1 should decrease as the resistance of R2 increases. Remember, the sum of the voltage drops must equal the applied voltage. If the voltage drop across R1 is decreasing, then the voltage drop across R2 must be increasing. Connect your test clips across R2 and see if this is true. Add the two voltage drops, they should equal E_a . (Remove test leads and de-energize the circuit.)

(Go to next frame.)

43. The diagram below illustrates a circuit with a variable resistor, a fixed resistor, and a source connected in series. The variable resistor is shown at three different settings.

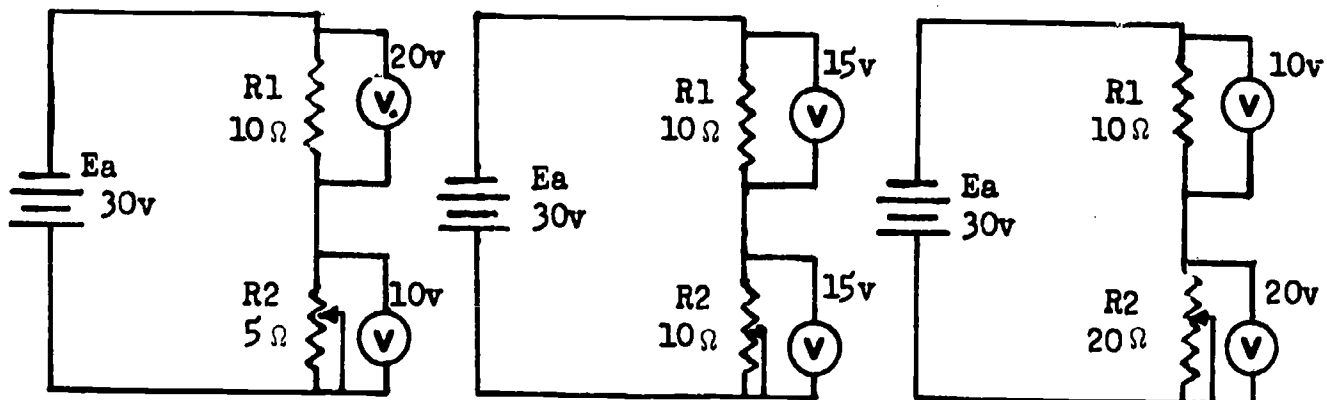

Check the statements that are true.

- a. The largest voltage drop will take place across the least resistance.
- b. The voltage drop across the variable resistor is always greatest.
- c. The voltage drop across the variable resistor will become greater or smaller as the resistance goes up or down.
- d. The voltage dropped across a fixed resistor always remains the same.
- e. The sum of voltage drops always equals the applied voltage.

(THIS IS A TEST FRAME. COMPARE YOUR ANSWERS WITH THE CORRECT ANSWERS GIVEN AT THE TOP OF THE NEXT PAGE.)

ANSWERS - TEST FRAME 43

- c. The voltage drop across the variable resistor will become greater or smaller as the resistance goes up or down.
- e. The sum of voltage drops always equals the applied voltage.

IF ALL YOUR ANSWERS MATCH THE CORRECT ANSWERS, YOU MAY GO ON TO TEST FRAME 44. OTHERWISE GO BACK TO FRAME 35 AND TAKE THE PROGRAMMED SEQUENCE BEFORE TAKING TEST FRAME 43 AGAIN.

44. Using Practice Board 0-1 and components available in the resource center, construct a series circuit as shown below.

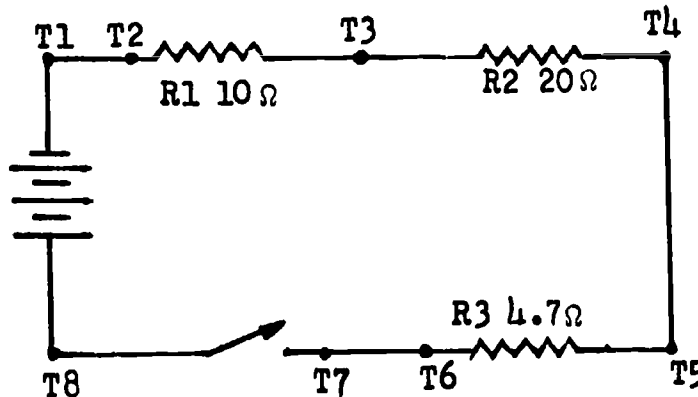

Energize the circuit then measure and record DC voltage at the points indicated below.

- a. Test points T2 to T3. _____ volts.
- b. Test points T3 to T4. _____ volts.
- c. Test points T5 to T6. _____ volts.
- d. Test points T7 to T8. _____ volts.
- e. Test points T1 to T8. _____ volts.

De-energize circuit and measure and record voltage at:

- f. Test points T7 to T8. _____ volts.

(THIS IS A TEST FRAME. COMPARE YOUR ANSWERS WITH THE CORRECT ANSWERS GIVEN AT THE TOP OF THE NEXT PAGE.)

ANSWERS - TEST FRAME 44

- a. 1.3 volts
- b. 2.6 volts
- c. 0.6 volts
- d. 0 volts
- e. 4.5 volts
- f. 4.5 volts

(All answers are approximate)

IF ALL YOUR ANSWERS MATCH THE CORRECT ANSWERS, YOU MAY GO ON TO TEST FRAME 52. OTHERWISE, SEE YOUR INSTRUCTOR BEFORE CONTINUING WITH THE PROGRAMMED SEQUENCE.

45. Modify the series circuit you have just constructed as indicated by the schematic.

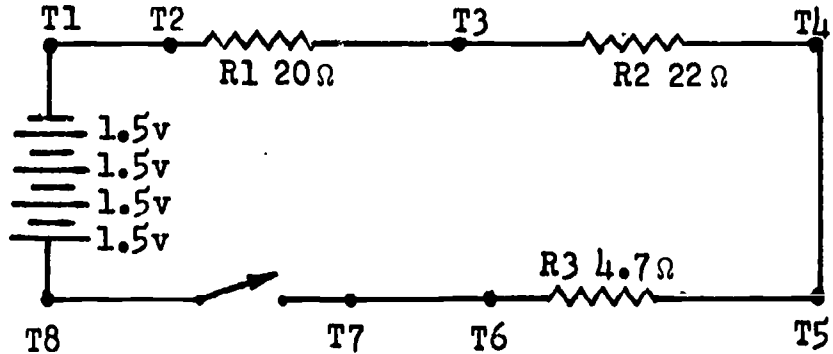

Energize the circuit. Read and record voltages at the points indicated.

- a. Voltage $\overline{T1}$ to $\overline{T8}$. _____ volts
- b. Voltage $\overline{T2}$ to $\overline{T3}$. _____ volts
- c. Voltage $\overline{T3}$ to $\overline{T4}$. _____ volts
- d. Voltage $\overline{T5}$ to $\overline{T6}$. _____ volts

(Approximately: a. 6 volts; b. 2.6 volts; c. 2.8 volts; d. 0.6 volts)

46. Modify your circuit as indicated by the schematic.

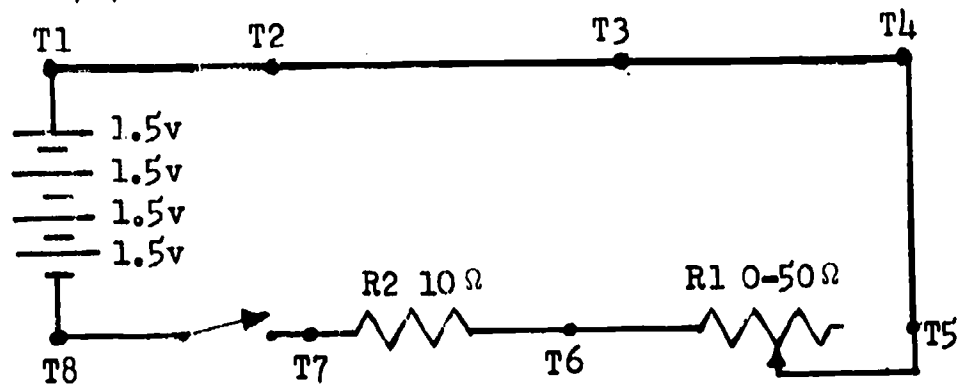

With variable resistor R1 adjusted to 30 ohms (use ohmmeter to adjust for 30 ohms) measure and record:

Circuit Energized:

- ___ a. applied voltage
- ___ b. E_{R1}
- ___ c. E_{R2}

With variable resistor set at 40 ohms (use ohmmeter to adjust for 40 ohms) measure and record:

Circuit Energized:

- ___ d. source voltage
- ___ e. E_{R1}
- ___ f. E_{R2}

(Approximately: a. 6 volts; b. 4.5 volts; c. 1.5 volts;
d. 6 volts; e. 4.8 volts; f. 1.2 volts)

47. Again, modify circuit as indicated by the schematic.

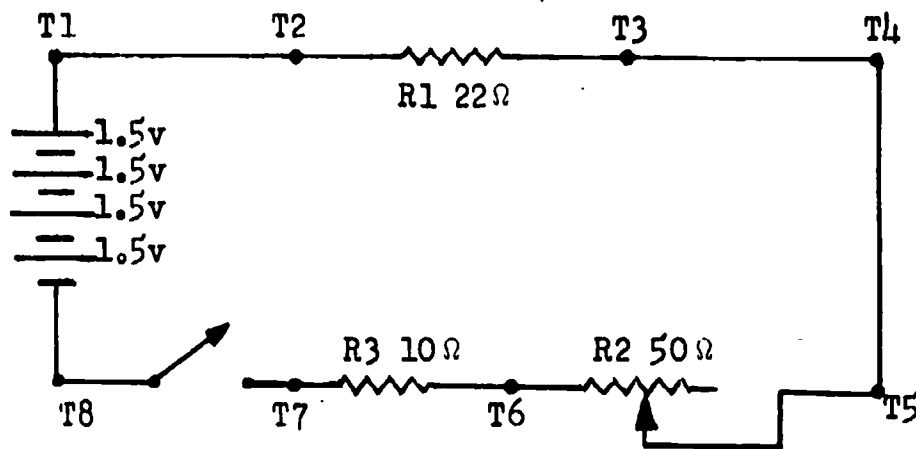

Energize Circuit:

Measure and record the voltage drops between the following points:

- a. $\overline{T1}$ to $\overline{T2}$. _____ volts
 b. $\overline{T2}$ to $\overline{T3}$. _____ volts
 c. $\overline{T5}$ to $\overline{T7}$. _____ volts

(Approximately: a. 0 volts; b. 1.6 volts; c. 4.4 volts)

48. Listed below are the steps for measuring 30-1000 volts DC. We will not actually measure voltages above 30 volts while in the school because of safety considerations. However, it is important that you understand how to set up the meter to do so. The most important thing to remember is that IF THE VOLTAGE TO BE MEASURED IS OVER 30 VOLTS, NEITHER THE TEST LEADS NOR THE METER SHOULD BE TOUCHED WHEN THEY ARE CONNECTED TO AN _____ CIRCUIT.

1. Set the function switch at +DC.
2. Plug black test lead into common (-) jack and the red test lead into the (+) jack.
3. Set the range switch in any of the five voltage-range positions. When in doubt about the voltage, always use the highest voltage range. Observe the meter reading. If the voltage is within a lower range the switch may be set for the lower range to obtain a more accurate reading. (NOTE: De-energize circuit before turning range switch.)
4. Connect the black test lead to the negative and the red test lead to the positive side of the circuit to be measured.
5. Turn on the power in the circuit to be tested. If the pointer deflects to the left of 0, the actual polarity is opposite the anticipated polarity. Turn off the power in the circuit. Set the function switch to -DC and turn the power on. This will correct the polarity as applied to the meter.
6. Read the voltage on the black arc marked DC.
7. Turn off the power in the circuit before disconnecting leads.

(ENERGIZED)

49. The Simpson 260-5P multimeter is also capable of measuring AC voltages. For AC voltages, the function switch must be placed in the AC position.

What function switch setting is used when measuring alternating current voltage?

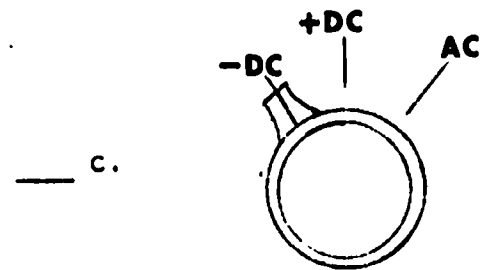
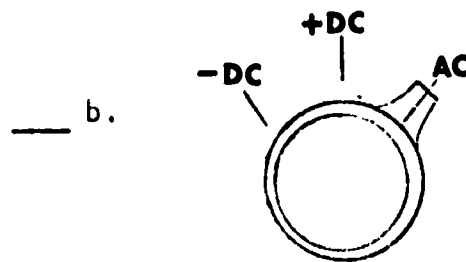
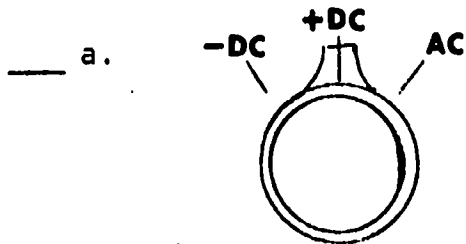

(b)

50. When measuring AC voltage, the polarity of the meter does not have to be observed, for the applied voltage changes polarity periodically. Which drawing shows the multimeter correctly connected for measuring AC voltage?

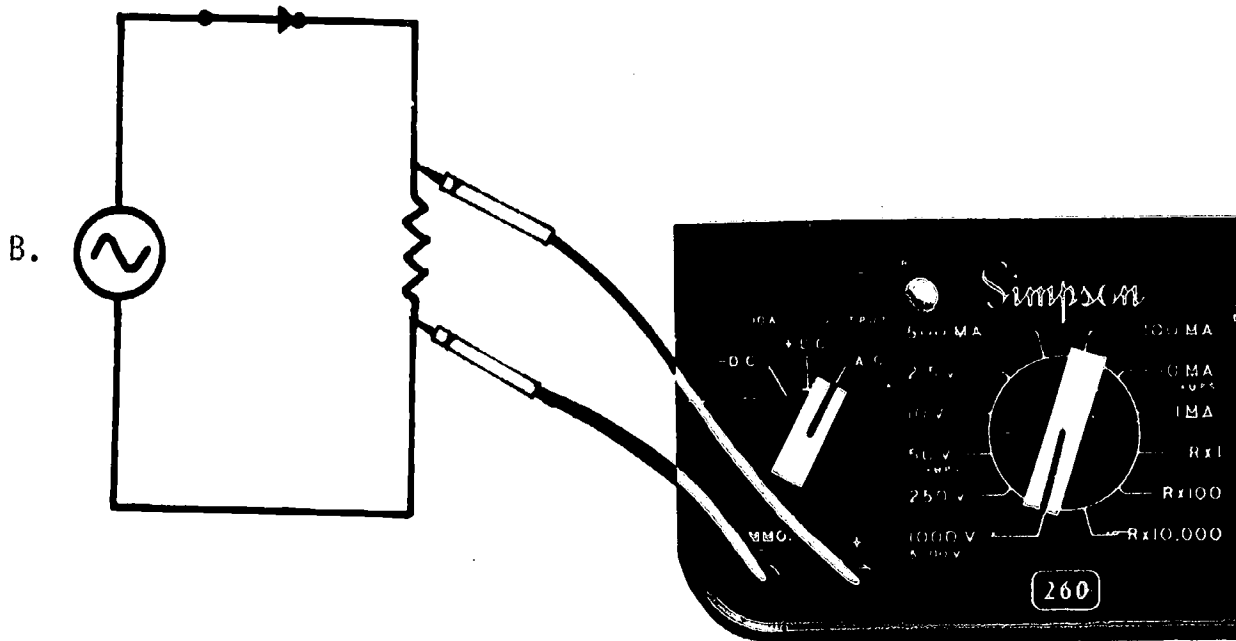
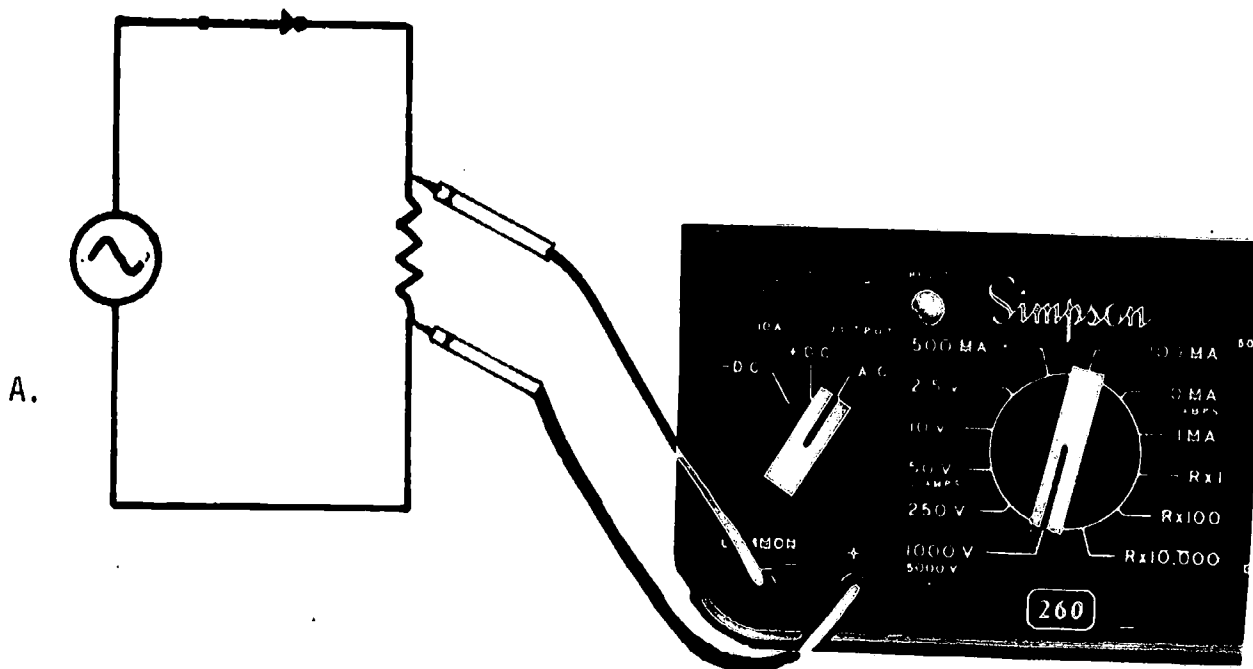

(A and B)

51. For reading AC voltages above 2.5v, the red arc marked AC and the three rows of numbers directly above the red arc are used. Which diagram correctly identifies the AC scales used for measuring AC voltage?

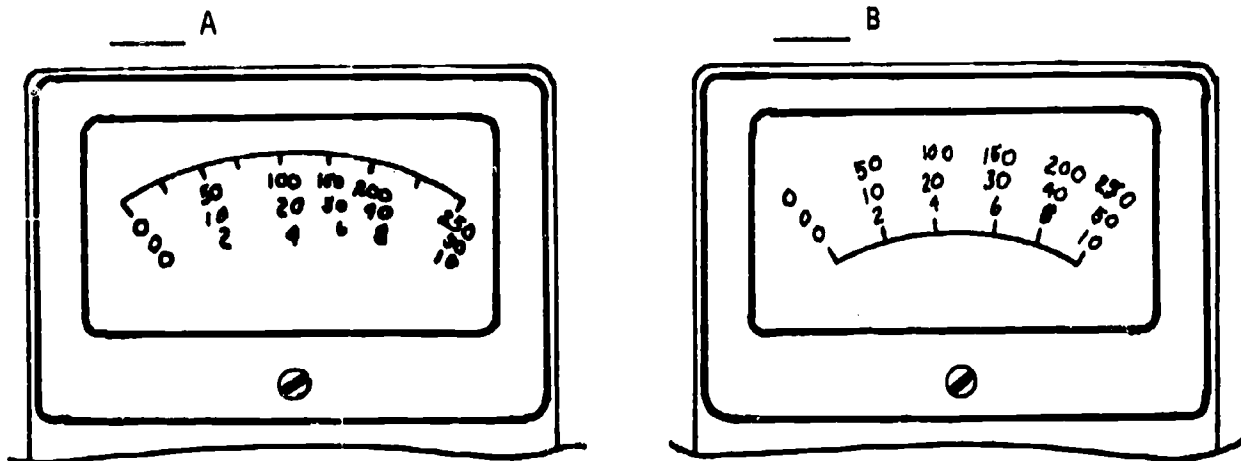

(B)

52. Check the statements that are true.

- a. Polarity does not have to be observed when measuring AC voltage.
 - b. The function switch is not used to measure AC voltages.
 - c. The black DC arc is used for measuring AC voltages.
 - d. The figures below the red AC arc are used for measuring DC voltages.
 - e. The figures below the red AC arc are used for measuring AC voltages.
-
-

(THIS IS A TEST FRAME. COMPARE YOUR ANSWERS WITH THE CORRECT ANSWERS GIVEN AT THE TOP OF THE NEXT PAGE.)

ANSWERS - TEST FRAME 52

- a. Polarity does not have to be observed when measuring AC voltage.
 - e. The figures below the red AC arc are used for measuring AC voltages.
-
-

IF ALL YOUR ANSWERS MATCH THE CORRECT ANSWERS, YOU MAY GO ON TO TEST FRAME 56. OTHERWISE, GO BACK TO FRAME 45 AND TAKE THE PROGRAMMED SEQUENCE BEFORE TAKING TEST FRAME 52 AGAIN.

53. The meter is interpreted the same way for AC as for DC except that the red AC scales are used.

Range switch on 2.5 v	- read the value directly on the red scale marked 2.5 vac only
on 1000 v	- multiply indicated voltage on the 0-10 AC scale by 100
on 10 v	- read voltage on 0-10 AC scale directly
on 50 v	- read voltage on 0-50 AC scale directly
on 250 v	- read voltage on 0-250 AC scale directly

Interpret the meter AC scale below by matching the indicated voltage to the range position.

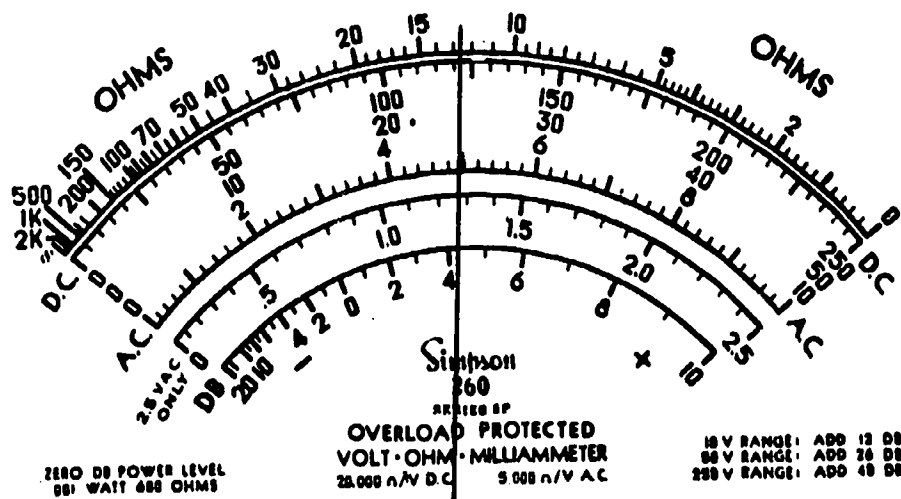

Range Switch Position	Voltage AC
1. 10 v	a. 500 volts AC
2. 50 v	b. 125 volts AC
3. 2.5 v	c. 25 volts AC
4. 250 v	d. 1.3 volts AC
5. 1000 v	e. 5 volts AC

(1. e; 2. c; 3. d; 4. b; 5. a)

54. Before proceeding with an actual AC voltage measurement, read the following safety precautions and keep them firmly in mind.

- DO NOT TOUCH THE METER OR TEST LEADS (EXPOSED METAL) WHILE POWER IS ON IN THE CIRCUIT BEING MEASURED.
- BE SURE _____ IS OFF WHEN CONNECTING AND DISCONNECTING TEST LEADS.

(POWER)

55. The voltage you will be measuring is at one point in your power supply. Measure only as instructed; otherwise you will be disregarding safety precautions and might encounter high voltages.

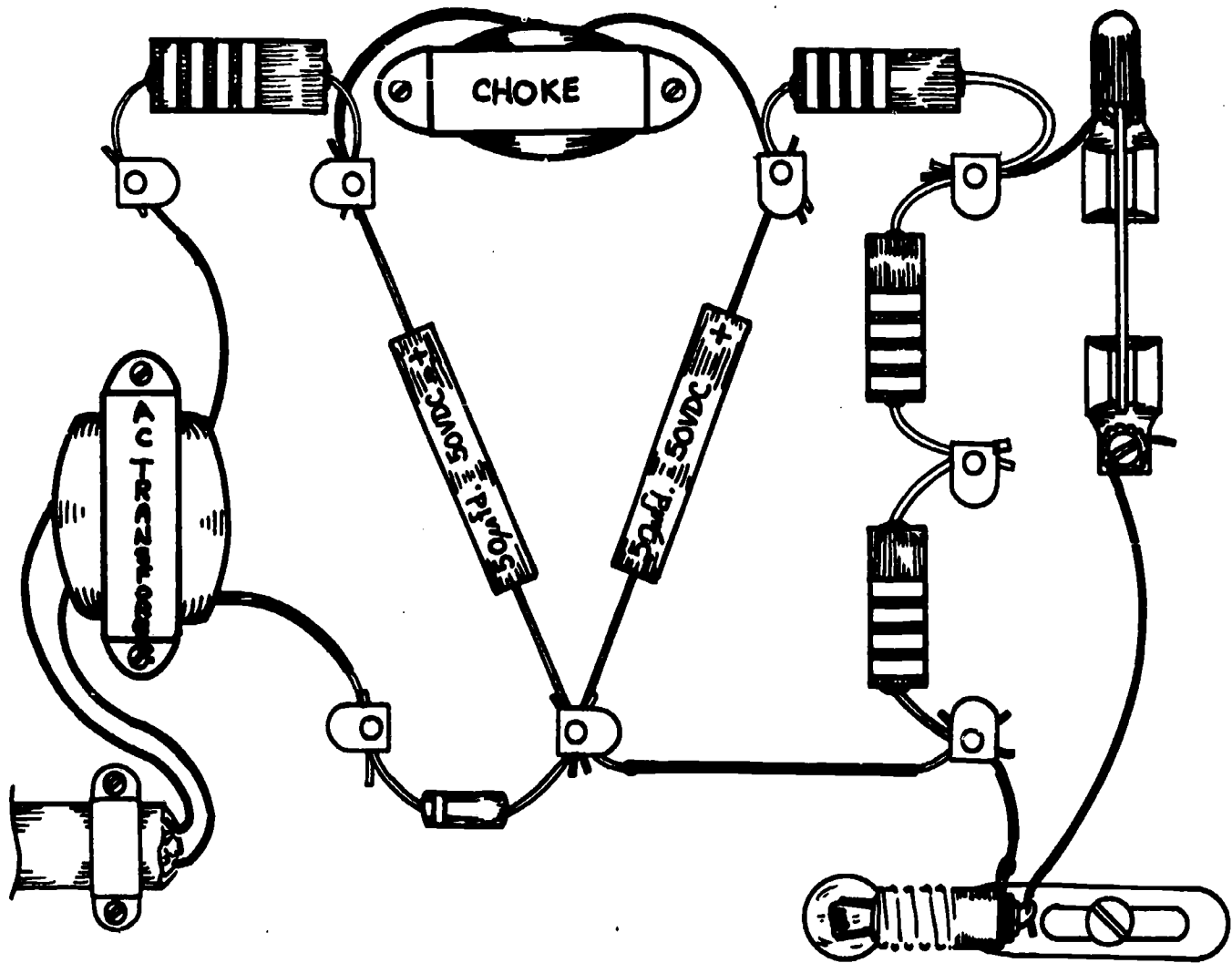

1. Be sure the switch in your power supply is open.
2. Set up the meter to read 0-1000 volts AC.
 - a. Set function switch to AC.
 - b. We will be reading a voltage between 20 v and 30 v, so place the range switch in the 50 v position.
 - c. Plug the black test lead into the common (-) jack and the red test lead into the (+) jack.
3. Since we are measuring AC voltage, polarity does not have to be observed. Connect leads across T1 and T8 (nowhere else).
4. Plug power supply into wall outlet and energize by closing the switch.
5. Record meter reading: _____ volts AC.
6. De-energize circuit and remove test leads.

(Step 5: voltage reading should be approximately 30 v AC)

56. Interpret the meter reading and record the indicated AC voltage for each range switch position.

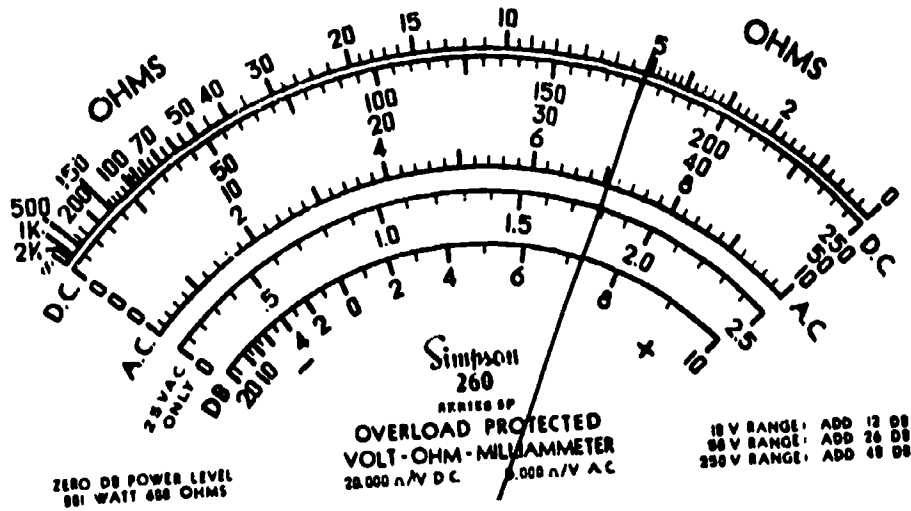

1. 10 v _____ volts AC
2. 50 v _____ volts AC
3. 2.5 v _____ volts AC
4. 250 v _____ volts AC
5. 1000 v _____ volts AC

(THIS IS A TEST FRAME. COMPARE YOUR ANSWERS WITH THE CORRECT ANSWERS GIVEN ON THE TOP OF THE NEXT PAGE.)

ANSWERS - TEST FRAME 56

1. 7.2 VAC
 2. 36 VAC
 3. 1.8 VAC
 4. 180 VAC
 5. 720 VAC
-
-

IF YOUR ANSWERS ARE INCORRECT, GO BACK TO FRAME 53 AND TAKE THE PROGRAMMED SEQUENCE.

IF YOUR ANSWERS ARE CORRECT, YOU MAY TAKE THE PROGRESS CHECK, OR YOU MAY STUDY ANY OF THE OTHER RESOURCES LISTED. IF YOU TAKE THE PROGRESS CHECK AND ANSWER ALL THE QUESTIONS CORRECTLY, YOU HAVE MASTERED THE MATERIAL AND ARE READY TO TAKE THE MODULE TEST. SEE YOUR INSTRUCTOR.

IF YOU DECIDE NOT TO TAKE THE PROGRESS CHECK AT THIS TIME, OR IF YOU MISSED ONE OR MORE QUESTIONS, STUDY ANY METHOD OF INSTRUCTION YOU WISH UNTIL YOU HAVE ANSWERED ALL THE PROGRESS CHECK QUESTIONS CORRECTLY. THEN SEE YOUR INSTRUCTOR AND ASK TO TAKE THE MODULE TEST.

SUMMARY
LESSON III

Using the Multimeter as a Voltmeter

You have learned to use the multimeter as an ohmmeter and as an ammeter; now let's discuss its use as a voltmeter.

Basically, all meters utilize current flow in making a measurement, for work is done in a circuit only when current flows. In other words, it is the current flow through the meter which causes the pointer to move. A voltmeter scale is calibrated so that it indicates the amount of voltage which causes current to flow through a multiplier resistor. The internal multiplier resistor determines the maximum voltage the meter can read and limits the meter current to a safe value. The range switch selects different meter ranges by selecting different multiplier resistors.

On the Simpson 260-5P, all DC voltages are read on the second scale from the top. Which of the three rows of numbers you read will depend on the range-switch setting. Some scales will require you to move the decimal point mentally to get the correct value.

The DC voltage ranges are 0 to 2.5 v, 0 to 10 v, 0 to 50 v, 0 to 250 v, and 0 to 1000 v. There is also a 0 to 5000 v scale which uses the 0 to 1000 v range switch setting with a special jack for the positive lead. The meter has corresponding AC voltage ranges which use the same numbers but are read on the red scale below the numbers. A separate 5000 v AC jack for the positive lead and a special scale for reading the 2.5 v AC range are the only differences from the DC functions.

To read voltages, you will use a method similar to the one used with the simple voltmeter. Make sure that the function switch (AC, -DC, +DC) is in the proper position and that the range switch is set at a larger value than the voltage you expect to measure before you touch your probes to the circuit. If you are not certain of the voltage, start with the highest scale (1000V) and reduce the range setting to get an easily read meter deflection. Do not reduce the range setting to a position that is below the voltage being measured.

The voltages you will be measuring here are all less than 30 volts, but later (in other schools or in the fleet) you will measure voltage in excess of 30 volts.

HIGH VOLTAGE MEASUREMENTS REQUIRE SPECIAL CARE TO PROTECT YOU FROM INJURY OR DEATH.

The special rule for measuring voltages in excess of 30 volts is:

Always de-energize the circuit before touching the meter, meter leads, or any part of the circuit.

The procedures to follow for making these readings are:

1. Turn off the circuit.
2. Connect the meter clip leads to the points where voltage is to be measured.
3. Set the meter function and scale as required. Check that connections are correct.
4. Keeping well away from the meter, leads, and circuit, energize the circuit and make the reading. If it is necessary to change any meter settings, turn off the circuit before you touch the meter.
5. Turn off the circuit and disconnect the meter.

If you are sure you understand how to use the multimeter safely as a voltmeter and you intend to take the progress check immediately following this summary, perform the experiments contained in the Narrative (pages 10-14). Keep both your safety, and the meter's safety in mind.

If you do not understand, first study either the narrative or the programmed instruction, or see your instructor.

AT THIS POINT, YOU MAY TAKE THE LESSON PROGRESS CHECK, OR YOU MAY STUDY THE LESSON NARRATIVE OR THE PROGRAMMED INSTRUCTION OR BOTH. IF YOU TAKE THE PROGRESS CHECK AND ANSWER ALL OF THE QUESTIONS CORRECTLY, YOU HAVE MASTERED THE MATERIAL AND ARE READY TO TAKE THE MODULE TEST. SEE YOUR INSTRUCTOR.

IF YOU DECIDE NOT TO TAKE THE PROGRESS CHECK AT THIS TIME, OR IF YOU MISSED ONE OR MORE QUESTIONS, STUDY ANY METHOD OF INSTRUCTION YOU WISH UNTIL YOU HAVE ANSWERED ALL THE PROGRESS CHECK QUESTIONS CORRECTLY. THEN SEE YOUR INSTRUCTOR AND ASK TO TAKE THE MODULE TEST.