

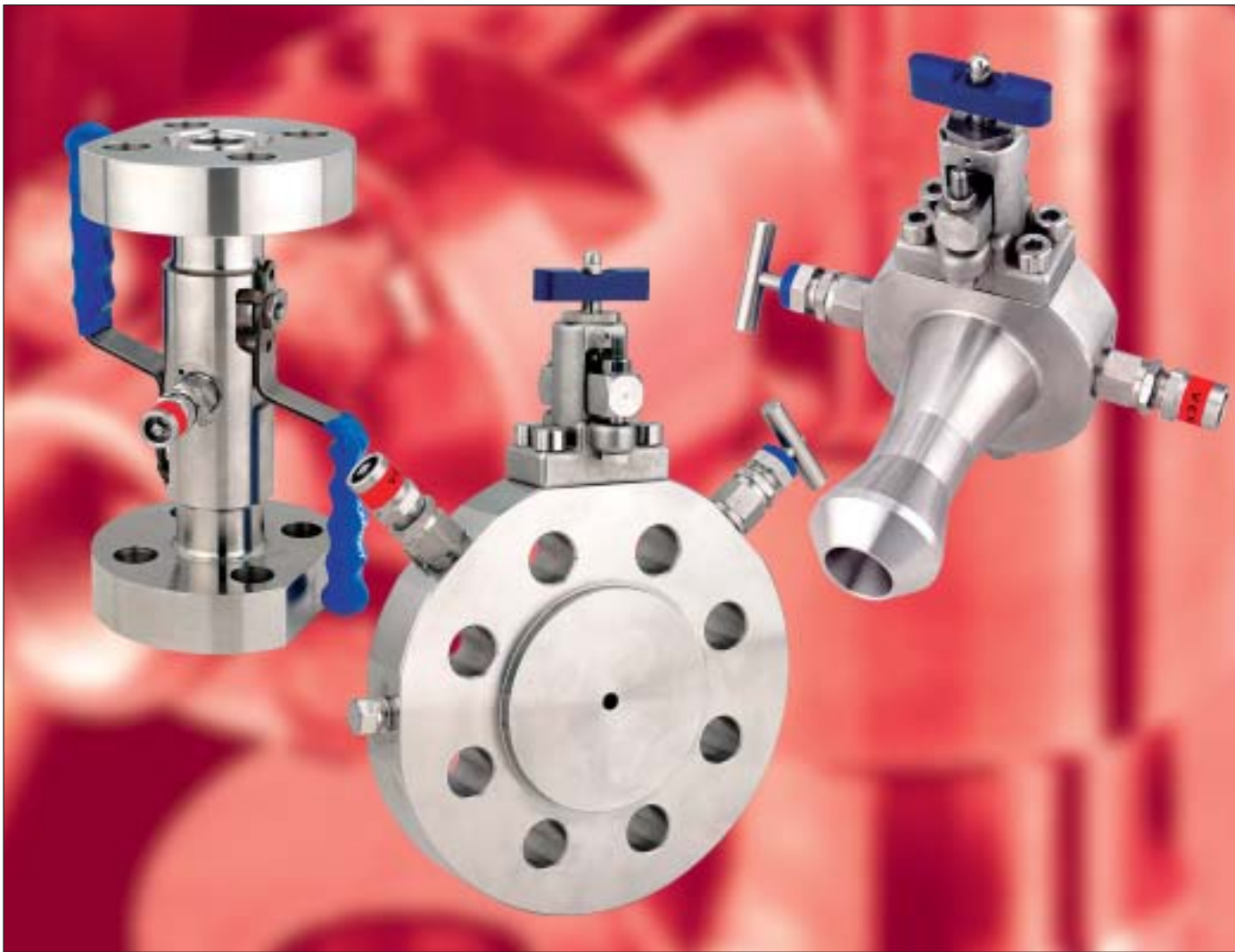









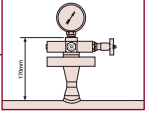

Double Block and Bleed Manifolds and Flanged Products

*Catalog 4190-FP
July 2001*

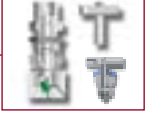

Flanged Products

Contents

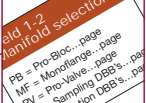
Page 3	Introduction	
Page 4/5	Application illustrations	
Page 6	Ball valve specification.	
Page 7	Outside screw and yoke (O.S & Y) valve specification.	
Page 8	Globe style needle valve specification.	
Page 9	Globe style needle valve with anti tamper bonnet. Miniature valve specification.	
Page 10/11	Monoflange double block and bleed manifolds.	
Page 12/13	Pro-bloc® double block and bleed manifolds.	
Page 14	Injection/Sampling double block and bleed valves.	
Page 15	Pro-valve double block and bleed valves.	
Page 16	Lapped joint tube connectors and kidney flanges	
Page 17	Flange to compression connectors	
Page 18/19	Part no's and ordering.	

Introduction

Parker Hannifin's response to the demand for reduction in leakage paths has been the combination of primary and secondary valves into one compact unit. The combining of piping and instrument valves into a single unit has benefitted various markets.

Benefits

- More compact design
- Reduced leakage paths
- Reduced vibration and pipework stresses
- Weight saving
- Reduced installation cost
- Choice of designs

Markets

- Offshore oil and gas platforms
- Onshore terminals
- Chemical, petro-chemical, refining
- Control panel manufacturers
- Process power industry
- LNG carriers



Parker Hannifin can offer the unique combination of double block and bleed valve systems together with integral fittings, both being designed and produced by one company. Selection of this combination results in the elimination of taper thread connections and the need for thread sealant.

For more information on leak path reductions and how to combine connections and valves into one unit, please contact us on manifolds@parker.com

Primary, secondary and vent valve applications and installations

Conventional installation

Typically this will feature a branch-welded flange, connected to a Primary ANSI class isolating valve of Ball, Gate, Globe or O.S.&Y. design. The outlet of the primary valve will be converted to instrument standards and will include a secondary instrument needle valve together with a bleed valve. A pressure gauge or transmitter will then be installed downstream of the instrument valves.

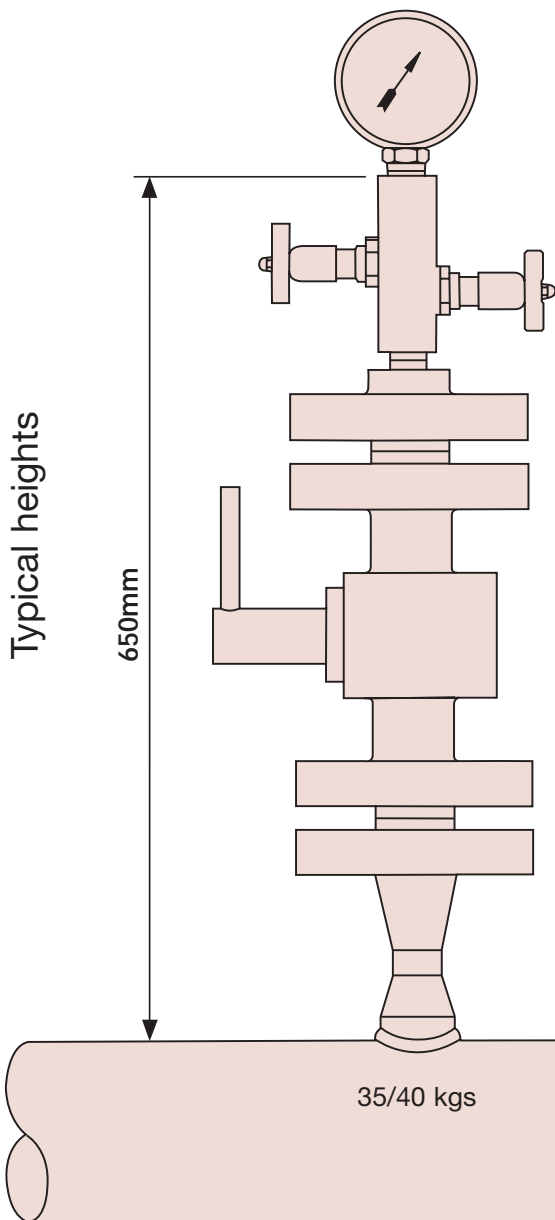

Parker Pro-Bloc®

Incorporates a body extending from a standard flange in a one-piece integral forged unit. Along the length of the extension it is possible to install and consolidate primary, secondary and bleed valves. At the end of the body extension a connection can be provided to suit any instrument, this connection could be a Parker A-LOK®, CPI™, pipe threaded NPT, BSPT, BSPP or pipe flange outlet. With Parker's Pro-Bloc® a choice of four valve designs are offered, Ball, O.S.&Y, Needle and Mini as a mixture or all of the same type. The Pro-Bloc® offers considerable space, weight and installation savings and improves safety factors through the reduction in connections.

See page 12/13 for details.

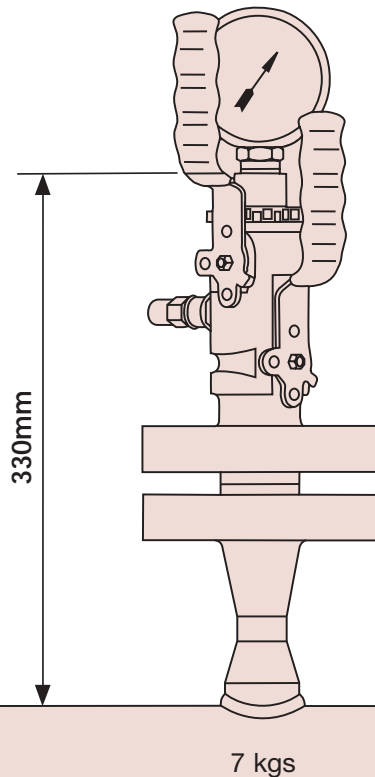

Typical

Solutions

Parker Hannifin offers the unique solution by incorporating primary and secondary valve systems into one complete block. In addition traditional instrument taper thread connections can be totally eliminated resulting in systems being free of thread sealant debris

Design codes

All Parker Hannifin Double block and bleed designs comply with the following codes.

ANSI/ASME B16.34 (Design/material)

ANSI/ASME B1.20.1 (Threads)

ANSI/ASME B16.5 (Dimensions)

API 607/BS6755 part 2 (Fire safety – subject to specification)

Parker Monoflange

This design is more compact than Pro-bloc® adding to further space and weight saving possibilities, primary, secondary and bleed valves are assembled on the periphery of the flange. The manifold body can incorporate both O.S.&Y. and instrument needle valves as a mixture or all of the same type. Monoflanges are available from forged or bar stock material. See page 10/11 for details.

Parker's New Pro-Valve

Adds a different dimension to the compact designs currently available; conventional Double Block and Bleed installations feature a pipe flange inlet bolted to a mating flange from the process line. The new Pro-Valve eliminates the need for these flanges having a weldable connection and valve body forged in the popular Weldolet® style. Standard O.S.&Y. and instrument valves can be assembled into the body giving the same functions of conventional double block and bleed manifolds. See page 15 for details.

Ball valve specification

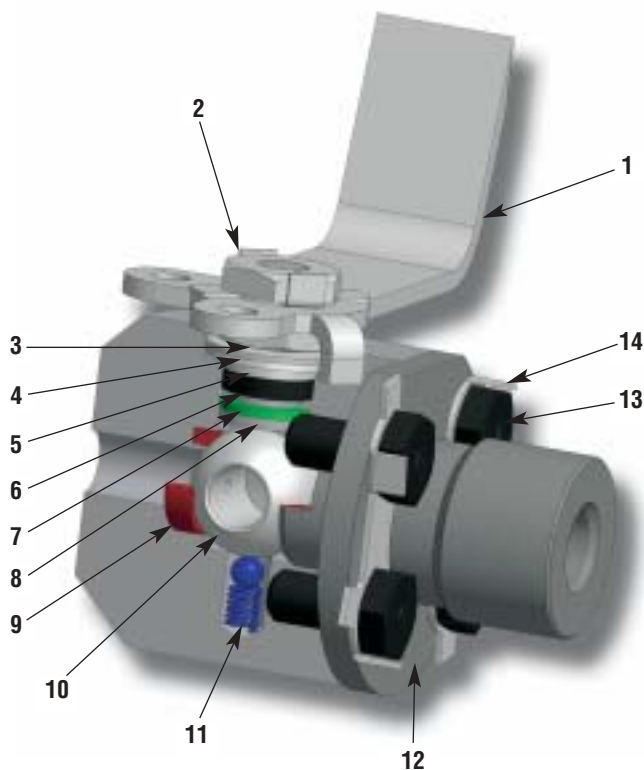

Features

- Stainless steel handle and positive machined stop.
- Full grip PVC handle sleeve.
- Vented ball for upstream relief and uni directional.
- Free floating ball design providing seat wear compensation.
- Available in 316L, Monel, Duplex, Super Duplex, Hasteloy, Inconel, Incoloy, 6Mo, Titanium, other materials on application.
- Stainless steel as standard.
- Optional handle locking available.
- Independent handle retaining locknut.
- Live stem seal packing.
- Vibration resistant gland nut.
- Anti blowout design.
- Low operating torque.
- Superior finished ball.
- Graphite stem disc for low torque operation.
- Anti static spring loaded ball standard.
- Colour coded and function identified handles.
- Ball seats PTFE or PEEK.
- Firesafe certified to API 607, BS 6755 Pt2.
- Fully encapsulated ball seats.
- Pressure rating up to 10,000 psig (690 bar).
- Temperature rating -57°C to +250°C (71°F to 482°F).
- Bore sizes available 3/8" (9.5mm), 1/2" (12.7mm), 3/4" (19.0mm).
- Optional: NACE compliance, heat code trace certification, oxygen clean

Pressure vs temperature

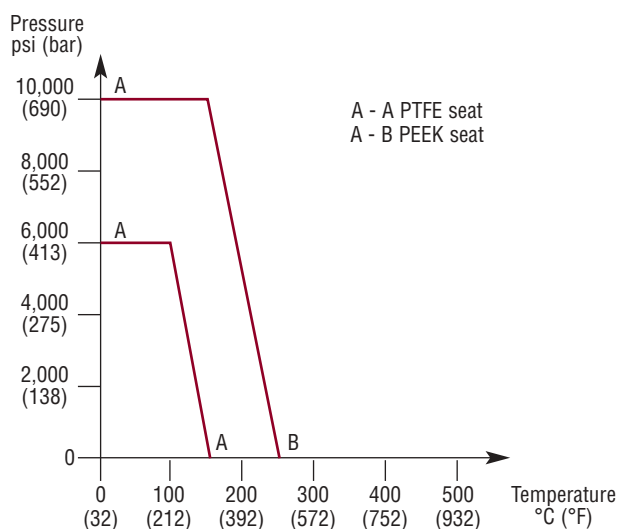

Part description

Item	Description
1	Handle and sleeve
2	Handle retaining nut
3	Gland nut
4	Live loading spring washers
5	Gland washer
6	Gland packing (Graphite std.)
7	Spindle disc
8	Spindle
9	Ball seat
10	Ball
11	Anti static spring and ball
12	Flanged end connector
13	Flange retaining bolts
14	Locking plate

Outside screw and yoke (O.S.&Y.) needle valve

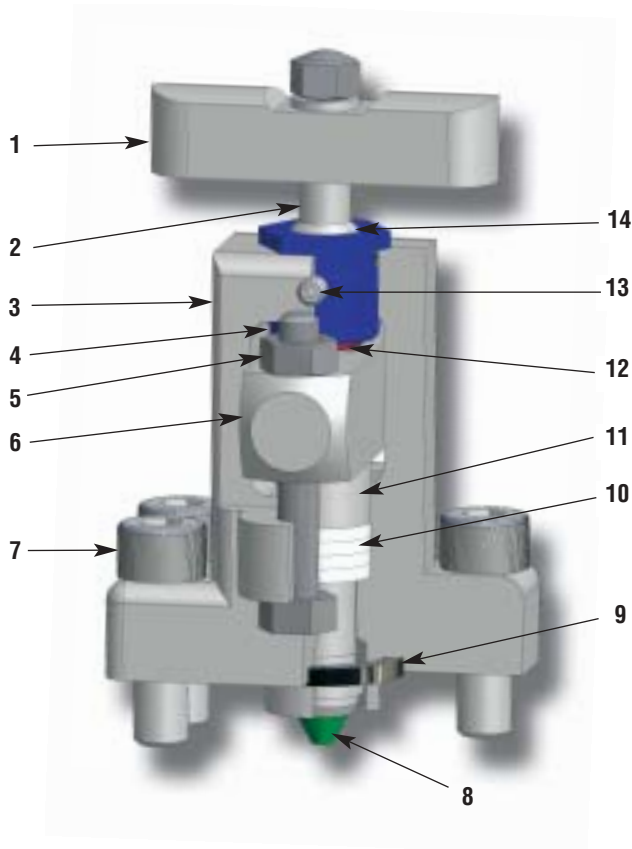

Features

- Externally adjustable gland.
- PTFE or Graphite packing for bubble tight sealing.
- Self centering crimped needle tip for bubble tight shut off and repeatability.
- Available in 316L, Monel, Duplex, Super Duplex, Hasteloy, Inconel, Incoloy, 6Mo, Titanium, other materials on application.
- Stainless steel as standard.
- Optional wetted parts in a variety of exotic materials.
- Firesafe certified to API 607 BS 6755 Pt 2.
- Pressure rating up to 10,000psi (690 bar).
- Temperature -54°C to 538°C (-65°F to 1000°F).
- Body to bonnet flange gasket for 100% atmospheric seal.
- Back stopped spindle for blow out prevention, and minimum atmospheric leakage.
- Rolled spindle operating threads.
- Independent spindle thread bush with maximum female thread interface.
- 'O' ring protected operating thread for prevention of ingress.
- Optional: NACE compliance, heat code trace certification, oxygen clean.

Pressure vs temperature

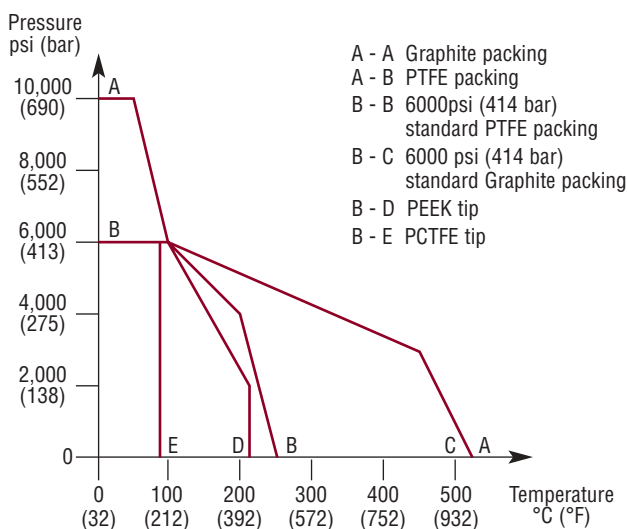

Part description

Item	Description
1	Handle assembly
2	Spindle
3	Yoke
4	Gland adjustment bolts
5	Gland adjustment nuts
6	Gland adjustment bar
7	Yoke retention bolts
8	Self centering spindle tip
9	Body to bonnet sealing gasket
10	Gland packing rings
11	Gland follower
12	Thread protection 'O' ring
13	Bush locking screw
14	Operating spindle bush

Globe style needle valve

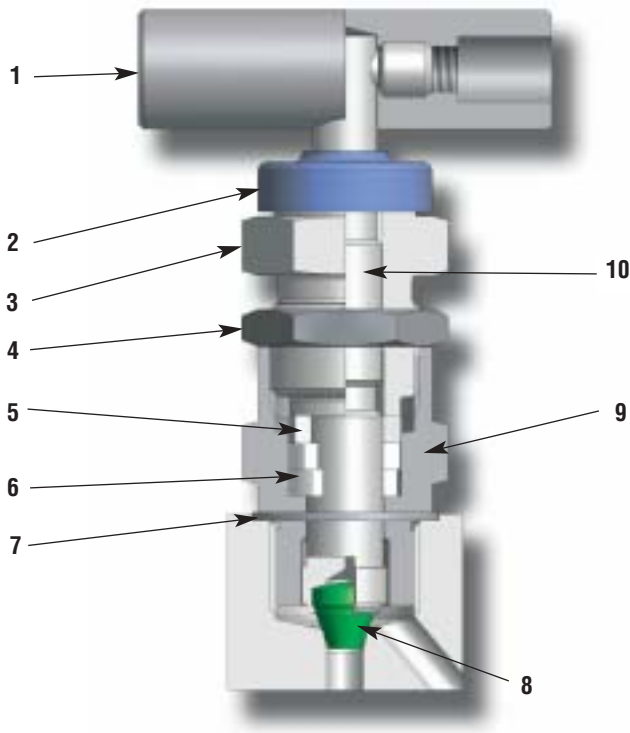

Features

- Rolled spindle operating threads for low torque operation.
- Gland packing in PTFE or Graphite for bubble tight sealing.
- Colour coded cap and function label for easy identification.
- Available in 316L, Monel, Duplex, Super Duplex, Hasteloy, Inconel, Incoloy, 6Mo, Titanium, other materials on application.
- T-bar operating handle for low torque function.
- Self centering crimped needle tip for bubble tight seat sealing.
- Close contact dust cap for operating thread protection.
- Back stopped spindle for blow out prevention and minimum atmospheric leakage.
- Adjustable gland with easy access.
- Gland lock nut for vibration protection.
- Pressure rating up to 10,000 psi (690 bar).
- Temperature rating -54°C to -538°C (-65°F to 1000°F)
- Optional bolted bonnet design available, firesafe certified.
- Optional: NACE compliance, heat code trace certification, oxygen clean.

Pressure vs temperature

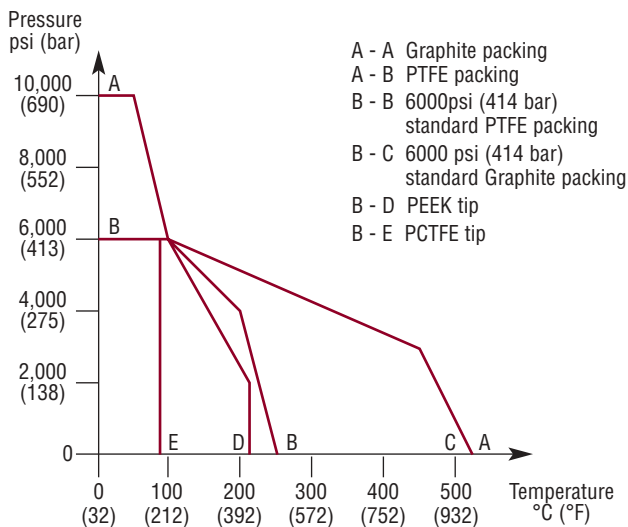

Part description

Item	Description
1	T bar handle assembly
2	Dust cap/function label
3	Gland adjuster
4	Gland locknut
5	Thrust bush
6	Gland packing (2)
7	Sealing washer
8	Self centering spindle tip
9	Bonnet stud
10	Spindle

Globe style needle valve with anti tamper bonnet



This style of valve is popularly used to prevent the accidental operation and release of fluid through the vent port to atmosphere.

For the valve to be functional the operator must obtain the separate key. Alternatively the key can be chained to the valve.

Pressure ratings and options are exactly the same as the standard T bar version.

Miniature valve bonnet

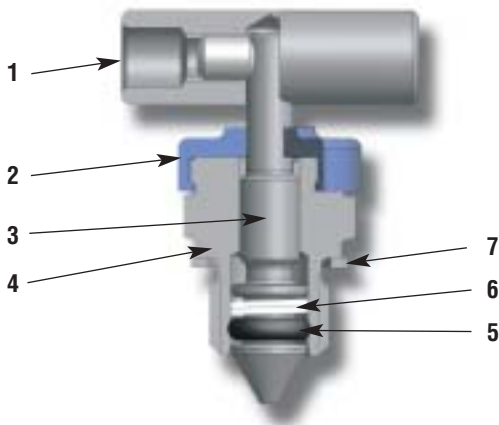

Pressure vs temperature

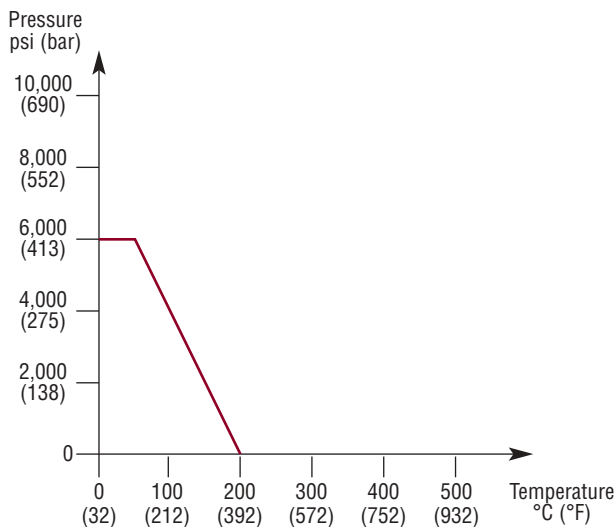

Features

- Compact design for size and weight savings.
- Pressure up to 6000 psi (414 bar).
- PTFE anti extrusion back up ring.
- Dynamic 'O' ring for bubble tight sealing.
- Back stopped spindle for blow out prevention and minimum atmospheric leakage.
- 316SS standard construction.
- Colour coded function label for ease of identification.
- Dust cap to prevent ingress of containments.
- Maximum temperature 204°C (400°F).
- Optional: NACE compliance, heat code trace certification, oxygen clean.

Part description

Item	Description
1	Handle
2	Dust cap
3	Spindle
4	Bonnet
5	'O' Ring
6	PTFE back up ring
7	Sealing washer

Monoflange (MF) double block and bleed manifolds

Purpose

Monoflange manifolds are designed to incorporate primary process valves (O.S.&Y.) together with standard isolation and vent needle valves in a one piece body to meet a variety of installation specifications. This compact, weight saving design is available to meet a large variety of customer requirements.



Flexible installation positioning options

Instrument outlets can be positioned to suit horizontal or vertically process pipelines.

Two outlets can be provided to suit any of the installations, the redundant outlet can be sealed with a blanking plug.

Additional outlet must be specified otherwise horizontal position only will be standard.

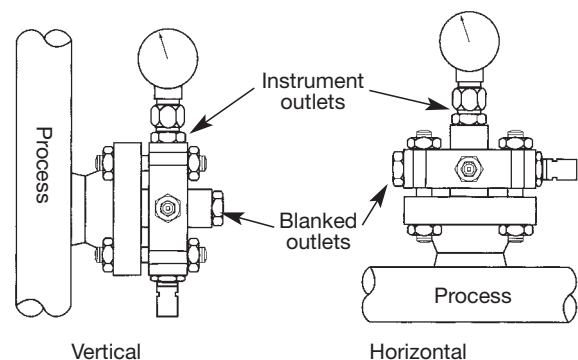

Flanged Products



Monoflange (MF) valve standard and optional positions

The standard double block and bleed arrangement requires a fire-safe primary isolate valve of O.S.&Y. globe pattern needle construction, bleed valve and secondary isolate of Instrument globe pattern needle construction. The standard industry sequence of valves is Block, Bleed, Block. A large number of variations of sequence, valve style and positions are available and are listed in the part number construction matrix.

Valve functional options

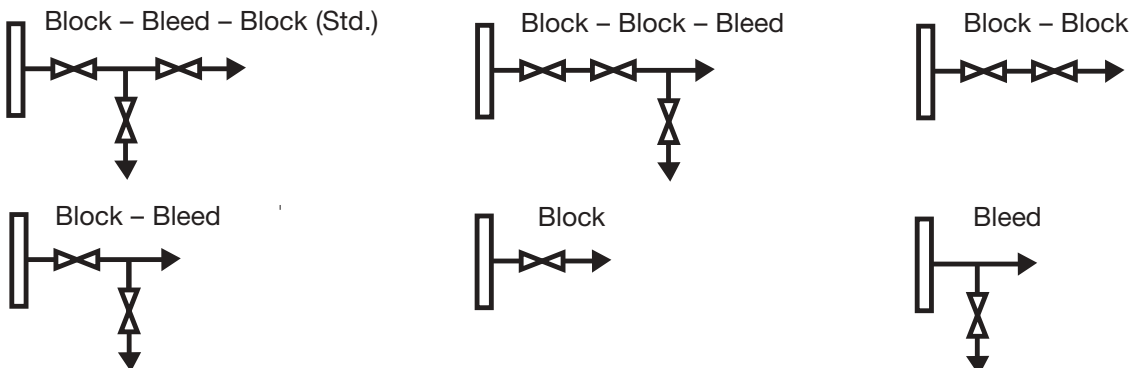

Specification

- 1/2 to 2" flanges (15 to 50NB).
- ANSI B16.5 150 to 2500lb flange class and 5000 - 10000lb API 6A.
- Instrument connections A-LOK®/CPI™, Pipe threads.
- RF smooth, RF rough and RTJ flange style faces.
- Firesafe certified to API 607, BS 6755 Pt 2.
- Forged construction flange standard.
- Bar stock optional.
- Available in 316L, Monel, Duplex, Super Duplex, Hasteloy, Inconel, Incoloy, Titanium. Other materials on application.
- Designed to meet ASME VIII DIV 1.

Features

- Outlets - A-LOK®/CPI™ 1/4" to 1" o.d. (3mm to 25mm o.d.), male and female threads, NPT, BSPT, BSPP and gauge sizes, ANSI flanged.
- Outside screw and yoke (O.S.&Y.) and Instrument needle valve available in any position.
- Heat code traceable material to EN10204.3.1.B.
- Bubble tight shut-off.
- Double vent and double outlet positions available.
- Universal mounting.
- Colour coded functional valves.
- Mini valves available.
- Optional anti-tamper instrument valves and lockable T bars available.
- NACE compliance available on request.
- DIN dimensional flanges available.

Pro-Bloc® (PB) double block and bleed manifolds

Purpose

This manifold range is designed to replace conventional multiple-valve instrument installations. By combining customer specified valves into a single manifold the number of leak paths is reduced and the mass of the system is lowered which reduces the stresses from loading and vibration. The manifold is machined from a one piece integral forging and features ball, O.S.&Y. and needle valves in combination or all of single design.

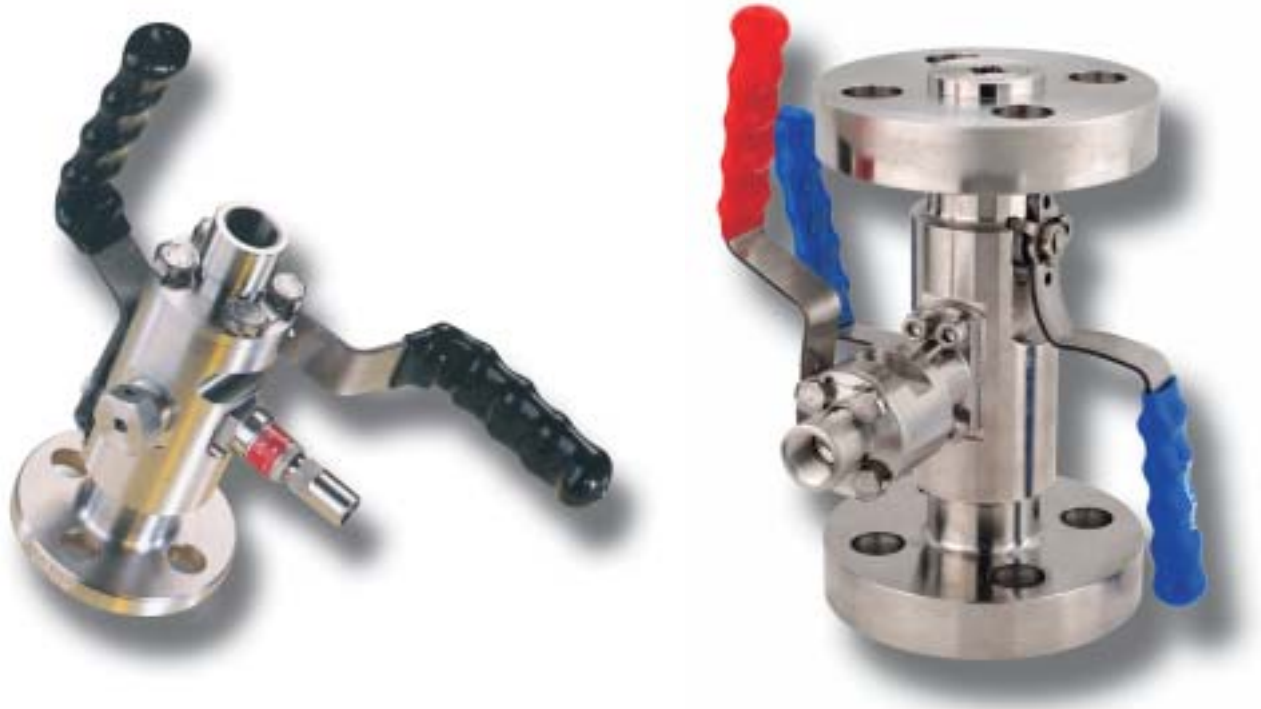

The standard double block and bleed arrangement requires a fire-safe primary isolate valve of Ball or O.S.&Y. globe pattern design. Bleed valve and secondary isolate can be the same as that which is selected for the primary isolate or a combination which can also include instrument style needle valves. Whilst standard specifications require the primary isolate to meet fire-safe approval standards any of the three types of valves Ball, O.S.&Y. and Needle can be offered to meet these approvals. The standard industry sequence of valves is Block, Bleed, Block or Block, Block, Bleed. A large number of variations of sequence, valve style and positions are available and are listed in the part number construction matrix.

To assist in the selection of the correct product, the following sequences and valve types represent 80% of the standard application demands.

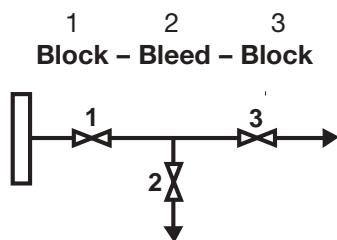

Valve 1 (primary) fire-safe ball or fire-safe O.S.&Y.
Valve 2 (bleed) anti-tamper needle valve.
Valve 3 (secondary) Ball, O.S.&Y. or needle

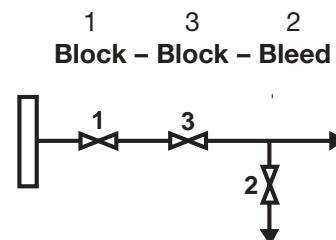

Valve 1 (primary) fire-safe ball or fire-safe O.S.&Y.
Valve 2 (bleed) anti-tamper needle valve.
Valve 3 (secondary) Ball, O.S.&Y. or needle

Flanged Products



Specification

- 1/2 to 2" flanges (15 to 50NB).
- ANSI B16.5 150 to 2500 flange class and 5000 - 10000 API 6A.
- Instrument connections A-LOK®/CPI™, Pipe threads.
- RF smooth, RF rough and RTJ flange style faces.
- Forged construction flange standard.
- Ball valve design to BS 5351.
- Firesafe certified to API 607, BS 6755 Pt 2.
- Available in 316L, Monel, Duplex, Super Duplex, Hasteloy, Inconel, Incoloy, 6Mo, Titanium, other materials on application.
- Designed to meet ASME VIII DIV 1.

Features

- Inlets/Outlets - Flanged, A-LOK®/CPI™ 1/4" to 1" o.d. (3mm to 25mm o.d.), male and female threads, NPT, BSPT, BSPP and gauge sizes.
- Ball, Outside screw and yoke (O.S.&Y.) and Instrument needle valve available in any position.
- Heat code traceable material to EN10204.3.1.B.
- Bubble tight shut-off.
- Colour coded functional valves.
- Mini valves available.
- Optional lockable Ball valves available.
- Lever stop integral in body.
- Optional anti-tamper instrument valves and lockable T bars available.
- NACE compliance available on request.
- Easy to follow customer part number construction matrix.
- Oxygen clean available.
- Optional upstream/downstream check valve.
- Large user friendly handles.
- Ball valve bore up to 19mm.

Injection (JD) double block and bleed valves

Purpose - injection probe

This design has been developed to facilitate the injection of chemicals and other media into the process stream. A single check valve is installed to prevent process fluid from reaching the inlet injection position. Injection nozzle orifice has a 0.125" (3mm) hole, the length can be manufactured to suit customer requirements and needs to be specified. The injection orifice can also be rotated. Injection valves can be provided in most of the styles and options offered for the DBB ranges.

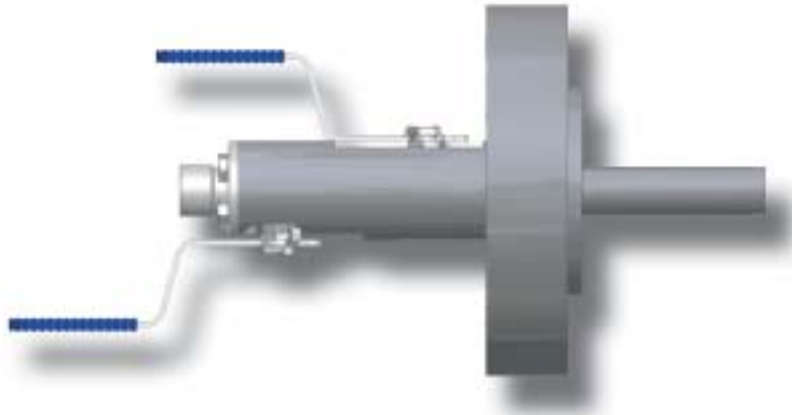

Sampling (SD) double block and bleed valves

Purpose - sampling probe

This design has been developed to remove a sample directly from the process stream at full system pressure. The customised sampling probe extends from the pipe flange connection for correct sample removal. Sampling valves can be provided without a probe and valves can be provided in most of the styles and options offered for the DBB ranges.



Flanged Products

Pro-Valve (PV) double block and bleed manifolds

Purpose

The Parker IPD Pro-Valve was designed to even further reduce the numerous leakage pathways created during conventional instrument manifold and gauge installation. Popular flanged double block and bleed arrangements are connected to a flange Weldolet® which itself needs welding to the process pipeline - the Pro-Valve eliminates the need for this flange connection. A one piece Weldolet® forging has been designed so that primary and secondary isolate valves together with bleed valve can be installed as a single unit. Reducing even further the number of leakage points.

Pro-Valve - the ultimate in leak path elimination



Specification

- Schedule pipe 40, 80, 160, XXS.
- To suit pipe diameters 3/4", 1-1.1/4", 1.1/2-6", 8-36".
- Instrument outlet connections A-LOK®/CPI™, pipe threads.
- Forged construction standard.
- Firesafe certified to API 607, BS 6755 Pt 2.
- Available in 316L, Monel, Duplex, Super Duplex, Hasteloy, Inconel, Incoloy, 6Mo, Titanium, other materials on application.

Features

- Outlets - A-LOK®/CPI™ 1/4" to 1" o.d. (3mm to 25mm o.d.), male and female threads, NPT, BSPT, BSPP and gauge sizes.
- Outside screw and yoke (O.S.&Y.) and Instrument needle valve available in any position.
- Heat code traceable material to EN10204.3.1.B.
- Valve functional options:- Double block and bleed, Single block and bleed, Isolate only.
- Bubble tight shut-off.
- Double vent and double outlet positions available.
- Colour coded functional valves.
- Mini valves available.
- Optional anti-tamper instrument valves and lockable T bars available.
- NACE compliance available on request.
- Easy to follow customer part number construction matrix.

Lapped joint tube adaptors (LJ)

Purpose

For applications involving small flanged process valves with simple conversion to instrument lines

Series LJ



Specifying

Refer to pages 18-19: for part number construction use fields: 1-2, 14, 15, 16, 17, 18, 19, 20. Ignore all other part no. fields.

Part no. example LJCASC-6A represents LJ adaptor in 316L barstock with inlet 1/2" pipe smooth spiral, 300lb flange, 3/8" A-LOK® outlet.

Specification

- 1/2" to 2" N.B. flanges (15 to 50DN).
- 150 to 2500lb flange class.
- Flange sealing:-
 - Raised face rough spiral finish.
 - Raised face smooth spiral finish.
- Standard or inverted A-LOK® arrangement 1/4" to 1" O.D. (3mm to 25mm O.D.).
- Standard or inverted CPI™ compression fitting 1/4" to 1" O.D. (3mm to 25mm O.D.).
- Standard stainless steel body (316L).
- Other materials on application.

Features

- Full heat code traceability to DIN 50049.3.1.B.
- Integrally machined body, no welding.
- Eliminates additional connections.
- P.T.F.E tape or liquid thread sealants not required.
- Appropriate lapped joint flanges available.
- Choice of smooth or rough spiral faces.
- NACE compliance available on request.

Kidney flanges to compression connectors (KF)

Purpose

Integral A-LOK® twin ferrule connection for simple, easy and safe connection from process measurement impulse line to instrument or manifold

Series KF



Specifying

Refer to pages 18-19: for part number. construction use fields: 1-2, 10, 14, 18-20 (outlet), 22 and 25 (if applicable) Ignore all other part no. fields.

Part no. example KFTD-4A represents Kidney flange in Monel with PTFE seal ring and 1/4" A-LOK® outlet.

Specification

- Rated to 6000psi.
- Standard to PTFE seal ring.
- Optional Graphite available.
- Standard stainless steel body (316L).
- Standard A-LOK® connection up to 1/2" or 12mm O.D. tube.
- Standard CPI™ connection up to 1/2" or 12mm O.D. tube.
- Other materials on application.

Features

- High tensile steel bolts standard.
- Full heat code traceability to DIN 50049.3.1.B.
- 1/2" NB Sch.40 to Sch XXS butt weld connections available.
- Offset threads available (specify in field 22).
- Integrally machined body, no welding.
- Eliminates additional connections.
- P.T.F.E tape or liquid thread sealants not required.
- NACE compliance available on request.

Flanged Products

Flange to compression connectors (FC)

Purpose

One piece integral connectors allow the user to switch from piping flange standards to instrument compression with minimum cost and added safety. This system eliminates the need for additional connections.

Series FC



Specification

- 1/2" to 2" N.B. flanges (15 to 50DN).
- 150 to 2500lb flange class.
- Flanges to ANSI B16.5.
- Standard or inverted A-LOK® compression fitting 1/4" to 1" O.D. (3mm to 25mm O.D.).
- Standard or inverted CPI™ compression fitting 1/4" to 1" O.D. (3mm to 25mm O.D.).
- Flange sealing:-
 - Raised face rough spiral finish.
 - Raised face smooth spiral finish.
 - Ring type joint.
- Standard stainless steel body (316L).

Features

- Full heat code traceability to DIN 50049.3.1.B.
- Integrally machined body, no welding.
- Eliminates additional connections.
- P.T.F.E tape or liquid thread sealants not required.
- Variety of materials available.
- NACE compliance available on request.

Specifying

Refer to pages 18-19: for part number construction use fields: 1-2, 14, 15, 16, 17, 18, 19, 20. Ignore all other part no. fields.

Part no. example FCCARDA12 represents flange connector in 316L barstock with inlet 1/2" pipe flange rough spiral raised face, 600lb flange, 12mm A-LOK® outlet.

Flanged Manifold Part Number Construction Guidelines

Please read these notes in conjunction with the part number matrix.

Whilst the use of flanged manifolds is a relatively simple principal the number of permutations of valves, connections, sizes, seals etc. makes a nomenclature construction necessary for accurate product specification.

By carefully following the guidelines below and completing the Part No. field you can ensure the correct selection of your requirements against which you can confidently process your enquiry and order.

If in doubt add a full product description ensuring that you have gone through all the Part No. fields that are listed and describe your requirements.

For your guidance: —

Field 1-2 Select the appropriate product.

Additional specifications will be required for SD i.e. length and position of the sample nozzle.

For JD injection nozzle details will be required.

Please state these details separately.

Field 3 Valve Sequences – all the sequences shown are possible with any of the manifolds selected. The most popular, and used by 80% of customers, is A – Block, Bleed, Block. Whichever selection is required insert the appropriate letter.

Field 4-9 Once the valve sequence (**Field 3**) has been decided, we need to know which type of valve will be used in which positions, we have coded the positions 1, 2 & 3. Any of the valves listed can be combined and fitted in any of the positions but you need to link these as shown in the example. If you need less than 3 valves for example you may choose **E** from **Field 3**, then you only need 1 valve, assume this is a Ball valve then in **Field 4-5** insert 1B and – in **Fields 6-9** e.g. **1B - - - -**

Note: it is not normal to fit Ball valves in Monoflange (MF)

Field 10 Is a straightforward choice between PTFE or Grafoil. If later in the part number construction you specify Firesafe (**Field 25**) then we will automatically fit Grafoil.

Fluorocarbon Rubber "O" ring packing is only available with the Mini head and will be automatically fitted.

If special gland packing materials are required give details separately, a part code will be issued.

Field 11-13 The choice of valve has been made in **Field 4-9** but we need to know the seating material/arrangement.

If different valves have been selected then the most appropriate seating selection should be made for each valve. If all valves are the same e.g. Ball and the seat material required is PTFE then only insert T in **Field 11** and – in **Field 12-13** e.g. **T - -**

If Mini bonnet is required this is standard only with metal to metal seat and no indicator is necessary for this, insert – in the appropriate field.

Field 14 Material selection is straightforward. Experience shows that specifications in the oil and gas industries will require St. St. in the forged condition. Lower cost product produced from Bar Stock is always available.

If other material is required insert **L** and specify separately. ALL NON-WETTED BONNET PARTS REGARDLESS OF THE SELECTED MATERIAL WILL BE SUPPLIED IN 316L ST. ST.

Flanged bodies supplied in Carbon Steel will always have St. St. valves.

St. St. grades 302 and 304 are NOT used in the construction of any of these products.

Field 15-17 NON-FLANGED INLET If non-flanged inlet is required then select from this list, if a fitting is required we will produce from the same material as specified in **Field 14**. Always complete the 3 **Fields** e.g. 1/2" A-LOK® insert **-8A** in **Fields 15-17**. For CPI™ change A to Z. For inverted A-LOK® change A to V. For inverted CPI™ change Z to X.

Field 15-17 PRO-VALVE If Pro-Valve is selected then we need the pipe schedule **Field 15** and **16**.

We also need the diameter of the process header pipe to which the Buttweld form will be welded (**Field 17**).

Field 15-17 FLANGED INLET Insert code for flange size (**Field 15**), face style (**Field 16**) and class (**Field 17**).

If flange class B or E is requested then the flange holes will be elongated to accommodate the range of class sizes shown.

If Grayloc Hub required **Field K** seal size should be stated separately.

Field 18-20 Specify the appropriate outlet using the same details listed for flanged/non-flanged inlets (**Fields 15-17**).

If 2 outlets are required for example 1/2" female, insert 8F in **Fields 18-19**, and **2** in **Field 20**. The position of these needs to be specified separately.

If flanged outlet is required then details must still be specified even if it is the same size as the inlet.

Field 21 Vent position/s need to be specified separately.

If flanged vent is required and it is the same size as inlet, insert **E** in **Field 21**.

F will indicate a different sized flange that will require a separate specification.

Field 22 If BSPP is specified we will unless otherwise instructed provide this with the "A" form washer seal face.

Field 23 Optional check valve we need to know the position in the PB, PV, SD or JD in which to install. Position A will be before primary isolate and B will be between the secondary and instrument.

Field 24 Standard ball valve bore is 9.5mm. Options up to 19mm.

We do not offer ball valves in excess of 19mm bore.

Field 25 If firesafe is designated, we will only supply the Primary isolate valve to meet the standard. If other valves are required to be fire-safe then these must be specified separately.

IMPORTANT

To avoid confusion please ensure when a field is not required a – is inserted into the particular field.

Flange bolts and gaskets are not provided.

Part No's and ordering

Quantity	Part No. field	1	2	3	4	5	6	7	8	9	10	11	12	13	14
	Customer completion														

Field 1-2 Manifold selection

MF = Monoflange...page 10/11
 PB = Pro-Bloc®...page 12/13
 SD = Sampling DBB's...page 14
 JD = Injection DBB's...page 14
 PV = Pro-Valve...page 15
 KF = Kidney Flanges...page 16
 LJ = Lapped Joints...page 16
 FC = Flange Connectors
 ...page 17

Field 14 Material

A = Carbon Steel ASTM A105/A696
 B = 316L St.St. ASTM A182 F316L Forging
 C = 316L St.St. ASTM A479 F316L Barstock
 D = Monel 400
 E = Duplex UNS 31803
 F = Super Duplex UNS 32760
 G = Hastelloy C-276
 H = Carbon Steel ASTM A350LFT Low temperature.
 J = Titanium
 K = 6Mo
 L = Incoloy 625
 M = Incoloy 825
 N = Other materials - please specify

Field 18-20 Non flanged outlet Positional details must be specified

Complete using details from non flanged inlets Fields 15-17 **A**

Field 18-20 Flanged outlets

Complete using details from flanged inlets Fields 15-17 **B**

Field 18-20 Pro-valve outlet

Complete using details from non-flanged inlets Fields 15-17 **A**

Field 3 Valve sequence

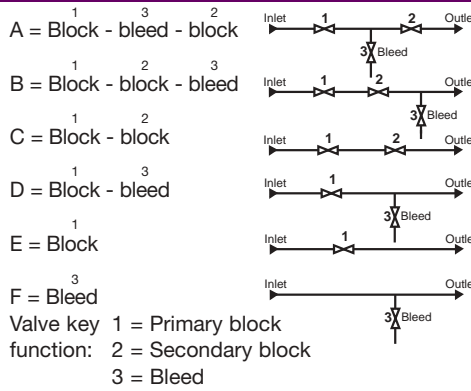

Field 4-9 Valve functions & type.

Valve key function:
 1 = Primary block
 2 = Secondary block
 3 = Bleed
 Combine the above in sequence with the valve type below e.g. 1B2B3N
 Type
 N = Instrument Needle (T bar)
 B = Ball
 Y = O.S.&Y (T bar)
 M = Mini bonnet (T bar)
 A = Lockable ball
 C = Lockable O.S.&Y.
 D = Lockable Inst. Needle
 E = Inst. Needle with anti-tamper

Field 15-17 Non flanged inlet

Field No		
15	16	17
-	8 = 1/2"	M = Male thread
-	8 = 1/2"	F = Female thread
-	8 = 1/2"	S = Socket weld
-	8 = 1/2"	B = Butt weld
-	8 = 1/2"	G = Swivel gauge adaptor
For 1/4" or 3/8" sizes of the above replace 8 with 4 (1/4) or 6 (3/8).		
-	4 = 1/4"	A = A-LOK® inch
-	6 = 3/8"	A = A-LOK® inch
-	8 = 1/2"	A = A-LOK® inch
Field No		
15, 16 and 17		
12A	3/4"	= A-LOK® inch
16A	1"	= A-LOK® inch
-A 3	3mm	A-LOK® metric
-A 6	6mm	A-LOK® metric
A 10	10mm	A-LOK® metric
A 12	12mm	A-LOK® metric
A 15	15mm	A-LOK® metric
A 16	16mm	A-LOK® metric
A 20	20mm	A-LOK® metric
A 25	25mm	A-LOK® metric

Field 15-17 Pro-valve

Field No	
15 and 16	17
Pipe Schedule	Pipe Header Size
PH = Sched. 160	M = 3/4" - 1.1/4"
PJ = Sched. XXS	N = 1.1/2" - 36"

Field 21 Flanged vent or threaded and plugged vent

A = 1 off 1/4" plugged vent
 B = 1 off 1/2" plugged vent
 C = 2 off 1/4" plugged vent
 D = 2 off 1/2" plugged vent
 E = Flange (same size as inlet)
 F = Flange different size to inlet (specify separately)

Field 22 Thread form

N = NPT
 R = BSPP
 K = BSPT
 F = Offset NPT
 for KF series only

Field 23 Options

Check valve preventing flow into process pipe.
 A = Upstream of Primary
 B = Downstream of secondary
 Check valve preventing flow into instrument/outlet
 C = Upstream of Primary
 D = Downstream of secondary

Field 24 Options

A = Std. 9.5
 B = 12.7mm
 C = 19mm

Flanged Products

15	16	17	18	19	20	21	22	23	24	25

Seal material		
Needle	Ball	O.S.&Y.
T	T	T
G	G	G
S	S	S

Carbon Rubber is used with Mini Bonnet

Field 11-13 Seats			
Seat	Field Number		
	11	12	13
	Ball	O.S.&Y	Needle
Metal/metal		H	H
Kel-f tip/seat		K	K
Peek tip/seat	P	P	P
PTFE seat	T		
Stellite tip		S	S
Stellite tip and seat		L	L
17/4 tip		F	F

Note: Mini bonnet only available in metal/metal seating.

Field 15-17 Flanged inlet B

Field No		
15	16	17
Flange inlet size	Flange face style	Flange class
A = 1/2" (DN15)	S = Raised face (smooth spiral)	A = 150
B = 3/4" (DN20)	R = Raised face (rough spiral)	B = 150/300/600
C = 1" (DN25)	T = Ring type joint	C = 300
D = 1.1/2" (DN40)		D = 600
E = 2" (DN50)		E = 900/1500
F = 3" (DN75)		F = 900
G = API 1-13/16"		G = 1500
H = API 2-1/16"		H = 2500
J = API 2-9/16"		J = 5000 API 6BX
K = Grayloc Hub		K = 10000 API 6BX

Ball valve bore
mm
n

Field 25 Options
N = NACE ①
D = Oxygen clean ②
F = Firesafe (primary block) ③
H = H.C.T. to EN10204.3.1.B ④
A = ① + ②
B = ① + ③
C = ① + ④
E = ① + ② + ③
G = ① + ② + ④
J = ① + ③ + ④
K = ① + ② + ③ + ④
L = ② + ③
M = ② + ④
N = ② + ③ + ④
P = ③ + ④

Other process products available include:-



CPI™ Tube Fittings, A-LOK® Tube Fittings, Instrumentation Pipe and ISO Conversion Fittings



Manifold Valves



Ball Valves, Rotary Plug Valves



Needle Valves, Metering Valves, Sample Cylinders and Accessories



TECHNOLOGY, APPLIED

Instrumentation Products Division Sales Offices

France - Paris

Tel: +33 14111 5390

Fax: +33 14111 0119

Germany - Frankfurt

Tel: +49 6134 204243

Fax: +49 6134 284227

Italy - Milan

Tel: +39 0245 1921

Fax: +39 0244 79340

Norway - Stavanger

Tel: +47 518 26 300

Fax: +47 518 26 301

Middle East - Abu-Dhabi

Tel: +971 26 788587

Fax: +971 26 793812

Finland - Vantaa

Tel: +358 9476 731

Fax: +358 9476 73200

Sweden - Flen

Tel: +46 157 43 4900

Fax: +46 157 43 4901



Parker Hannifin plc

Instrumentation Products Division

Riverside Road

Pottington Business Park

Barnstaple, Devon EX31 1NP

England

Tel: +44 (0)1271 313131

Fax: +44 (0)1271 373636

Email: ipd@parker.com

www.parker.com/ipd



Visit us on the web at www.parker.com/ipd