



**DRAFT**  
**Safety Manual for**  
**Construction, Operation &**  
**Maintenance of Distribution**  
**Network**



**Prepared for the Employees of**  
**Tamil Nadu Generation & Distribution Corporation Ltd.**



## **SAFETY POLICY**

TANGEDCO, involving in Generation & Distribution of Electricity in the State of Tamilnadu, accepts its moral responsibility in providing safe and secure working environment to all its employees in construction, operation and maintenance of electricity distribution system and its associated Sub Stations, including public as an integral part of its value system.

**“SAFETY FIRST - WORK NEXT”** is our motto which emphasizes that all work shall be taken up with utmost care giving top priority to safety. Safety will be inculcated in the mind of our employees so that Safe, Healthy and Accident free work place is created for themselves, their co-workers and to the General Public.

We believe that accidents are preventable through the continual improvement in the working environment and the active involvement of employees at all level. To make this happen, we will enhance the awareness, skill and competency level of our Field staff, Supervisors and Engineers with consistent & continual support and to make them feel responsible and accountable towards making TANGEDCO safe and accident free.

**Chairman-cum-Managing Director  
Tamil Nadu Generation & Distribution Corp. Ltd.**



# Content

<b>SL.NO.</b>	<b>NAME OF THE TOPIC</b>	<b>PAGE NO</b>
1	Preamble	1 - 2
2	Definition	3 - 4
3	General safety requirements	5 - 14
4	Safety – Roles & Responsibilities.	15 - 19
5	Electrical Personal Protective Equipments(PPE) and Tools	20 - 30
6	Safety in Construction Work	31 - 51
7	Safe Working in Sub Station	52 - 66
8	Safe working in Operation & Maintenance of HT/LT Lines/Cables and Equipments	67 – 75
9	Effective Earthing Practices to Ensure Safety	76 - 84
10	Safety in Consumer premises	85 – 88
11	Standard Distances and Clearances	89 – 101
12	Prevention of Fire & Fire fighting techniques	102 – 118
13	General First Aid	119 – 126
14	Accident – Reporting & Auditing	127 – 130
15	Permit to Work.	131 – 140
16	Important Case Studies	141 – 161
Annexure - I		162 – 163
Annexure - II		164
Annexure – III		165 – 172
Annexure - IV		173 - 174

## **Preamble :**

Tamil Nadu Electricity Board (TNEB) was formed on July 1, 1957 under section 54 of the Electricity (Supply) Act 1948 in the State of Tamil Nadu as a vertically integrated utility responsible for power generation, transmission and distribution. The electricity network has since been extended to all villages and towns throughout the State. As per the provisions under the section 131 of the Electricity Act, 2003 TNEB was restructured on 1.11.2010 into TNEB Limited; Tamil Nadu Generation and Distribution Corporation Limited (TANGEDCO); and Tamil Nadu Transmission Corporation Limited (TANTRANSCO).

As per Indian Electricity Rules 1956, TNEB published its Electrical Safety Manual for Generation, Transmission and Distribution in the year 1965, in order to emphasise Electrical safety in the regular day to day work for its employees. This manual along with its amendments existed for nearly six decades.

The Indian Government (Ministry of Power) has enacted, **“The Electricity Act 2003 (36 of 2003)”**, on 10.06.2003 repealing the pre existed, “Indian Electricity Act – 1910, Supply Act 1948 and Electricity Regulatory Commission Act 1998”.

In section 185, subsection (2) clause (c) of the Act, it is stated that, “The Indian Electricity Rules 1956 made under section 37 of the Indian Electricity Act 1910 (9 of 1910) as it stood before such repeal shall continue to be in force till the regulations under section 53 of this Act are made”

In exercise of the power conferred by clause (c) of section 73 read with subsection (2) of section 177 of the Act, the Central Electricity Authority New Delhi, made the regulations called “Central Electricity Authority (Measures relating to Safety and Electricity Supply) Regulations, 2010”. And “Central Electricity Authority (Safety Requirements for Construction, Operation and

Maintenance of Electrical Plants and Electric Lines) Regulations, 2011". The regulation so formed by the authority along with its amendments replaces the Indian Electricity Rules 1956 and shall apply to all electrical plants and electric lines already commissioned as well as those under construction.

In section 4 ( c ) & 5 of Central Electricity Authority (Safety Requirements for Construction, Operation and Maintenance of Electrical Plants and Electric Lines) Regulations - 2011, it has been directed to prepare a detailed safety manual covering topics detailed in Annexure I & Annexure II of the above regulation.

In section 16 ( 3 ) ( j ) of Tamil Nadu Electricity Distribution Code specified by Tamil Nadu Electricity Regulatory Commission ( TNERC ) it has been instructed to prepare a Safety Manual incorporating all operating procedures in addition to safety rules and safety precautions applicable to distribution system and the Consumer's system and circulate the same among all staff concerned and Consumers for strict adherence.

Hence, in order to comply with the directions issued by the Authority and the Commission, and to revise the six decades old Safety Manual to cover the topics specified in Annexure I & Annexure II of Central Electricity Authority (Safety Requirements for Construction, Operation and Maintenance of Electrical Plants and Electric Lines) Regulations - 2011, this Safety Manual has been prepared.

This Safety Manual deals with the General & Special safety requirements that needs to be followed while carrying out Construction, Operation & Maintenance of Distribution Network and its associated Sub Stations of TANGEDCO.

The voltage level covered under this manual is

Low Tension (LT) – Up to 250 V

Medium Voltage(MV) – exceeding 250 V up to 650 V

High Tension (HT) – above 650 V up to and inclusive of 33 KV Network

# Definitions

To clarify the intent and meaning of the wording used in this Safety Manual, the following definitions are given. All words / expressions used herein and not defined shall have the meanings assigned to them in the Indian Electricity Act – 2003 and Central Electricity Authority ( Measures relating to Safety and Electricity Supply) Regulations, 2010, Central Electricity Authority (Safety Requirements for Construction, Operation and Maintenance of Electrical Plants and Electric Lines) Regulations - 2011 and its amendments.

1. “accident” may be defined an unfortunate incident that happens unexpectedly and unintentionally, typically resulting in damage or injury.
2. “Act” means the Electricity Act 2003 (36 of 2003)
3. “Authority” means a body to be called the Central Electricity Authority to exercise such functions and perform such duties as are assigned to it under section 70 of Electricity Act 2003.
4. “Apparatus” means electrical apparatus and includes all machines, fittings, accessories and appliances in which conductors are used.
5. “Bare” means not covered with insulating materials.
6. “Circuit” means an arrangement of conductor or conductors for the purpose of conveying electricity and forming a system or a branch of a system.
7. “commission” mean Tamil Nadu Electricity Regulatory Commission
8. “conductor” means any wire, cable, bar, tube, rail or plate used for conducting electricity and so arranged as to be electrically connected to a system.
9. “danger” means danger to health or danger to life or any part of body from shock, burn or other injury to persons, or property, or from fire or explosion, arising out from working on generation, transmission, transformation, conversion, distribution or use of electricity.
10. “earthed” or “connected with earth” means connected with the general mass of earth in such manner as to ensure at all times an immediate discharge of electricity without danger.

11. "earthing system" means an electrical system in which all the conductors and appliances are earthed.
12. "Electrical shock" is an unwanted or unnecessary physiological response to electric current
13. "Fuse" is a short piece of element inserted in the circuit which melts when excess current flows through it and breaks the circuit.
14. "Insulators" are used to provide necessary insulation between line conductors and supports to prevent the leakage current from conductor to Earth.
15. "Isolators" are used to disconnect the part of the system for General Maintenance and repair.
16. "Lightning arrester" is a protective device which conducts only the high voltage surge on the power system to ground.
17. "live" means electrically charged.
18. "near miss" a narrowly avoided accident.
19. "occupier" means the owner or person in occupation of the premises where electricity is used or proposed to be used.
20. "poles" means the phase terminals of a switch.
21. PPE-Personal protective equipment such as hand gloves, Waist belt rope, Earth / Discharge rods, helmets etc. used for personal protection.
22. "Safety Gloves" are the protective material used by the workmen while working with Electrical equipment.
23. "span" means the horizontal distance between two adjacent supporting points of an overhead conductor.
24. "system" means an electrical system in which all the conductors and apparatus are electrically connected to a common source of electric supply.

## GENERAL SAFETY REQUIREMENTS

Electrical safety is a system of organizational measures and technical means to prevent harmful and dangerous effects on workers from electric current, electric arc, electromagnetic field and static electricity.

Electrically powered equipment can pose a significant hazard to workers, particularly when mishandled or not maintained. The major hazards associated with electricity are electrical shock, fire, arc flash, burns, death and damage to the properties

Electrical shock occurs when the body becomes part of the electric circuit, either when an individual comes in contact with both wires of an electrical circuit, one wire of an energized circuit and the ground, or a metallic part that has become energized by contact with an electrical conductor.

The severity and effects of an electrical shock depend on a number of factors, such as the pathway through the body, the amount of current, the length of time of the exposure, and whether the skin is wet or dry.

The effect of the shock may range from a slight tingle to severe burns to cardiac arrest. The chart below shows degree of injury to a human being caused by alternating current ( I ) of duration ( T ) passing from left hand to feet as defined in IEC publication 60479-1

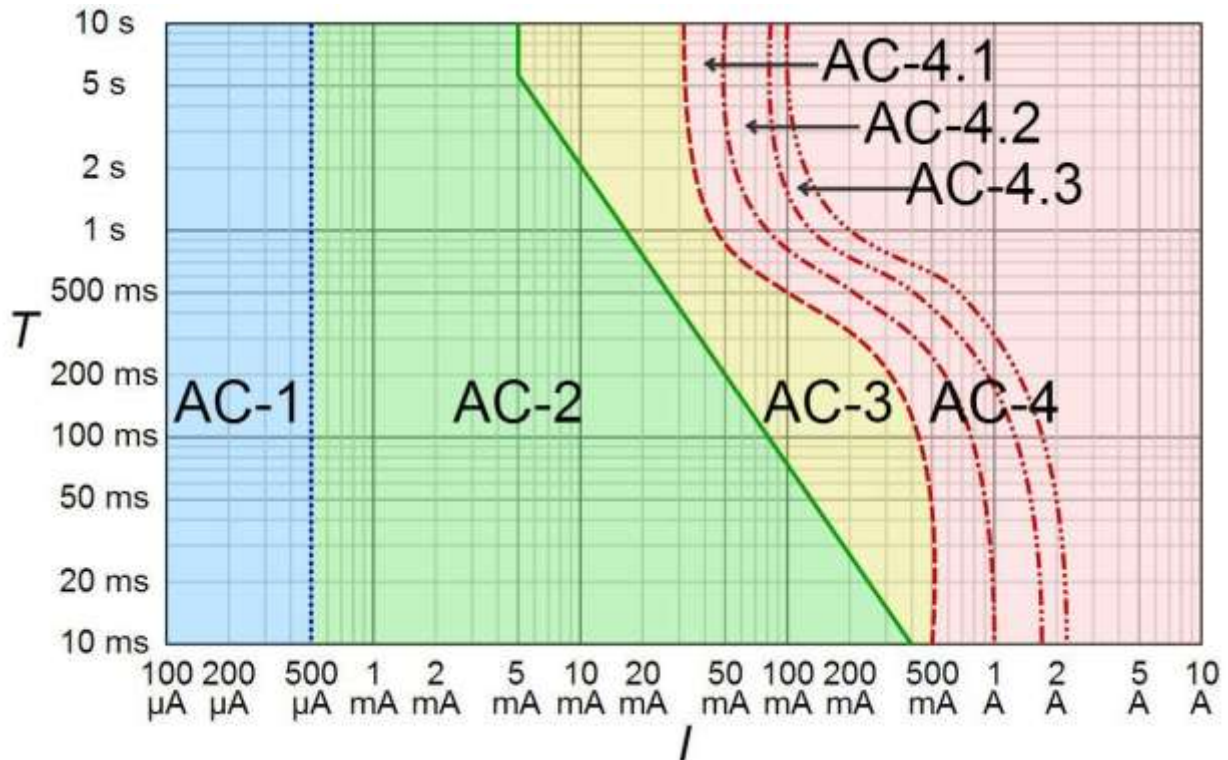

AC 1	imperceptible
AC 2	perceptible but no muscle reaction
AC 3	muscle contraction with reversible effects



AC 4	possible irreversible effects
AC 4 - 1	up to 5% probability of ventricular fibrillation
AC 4 - 2	5-50% probability of fibrillation
AC 4 - 3	over 50% probability of fibrillation

A hazardous arc flash can occur in any electrical device, regardless of voltage, in which the energy is high enough to sustain an arc. Potential places where this can happen include:

- Panel boards and switchboards
- Motor control centres
- Metal clad switch gear
- Transformers
- Motor starters and drive cabinets
- Fused disconnects
- Any place that can have equipment failure
- Short circuits
- Loose connections in current carrying path
- Improper handling of AB switches
- Aged conductors & Line materials

In an arc flash incident, an enormous amount of concentrated radiant energy explodes outward from electrical equipment. The explosion creates pressure waves that can damage a person's hearing, a high-intensity flash that can damage their eyesight and a superheated ball of gas that can severely burn a worker's body and melt metal.

An Electrical Accident is an undesirable, incidental, and unplanned event that occurs due to negligence of safety measures by an individual. Safe working mean, working in an Electrical system without causing any damage or injury to themselves; to their co workers; to general public; or to the equipments maintained by him. Safe working measures eliminates or minimises the hazards of electricity.

To an individual an electrical accident can cause temporary reversible ailment, permanent irreversible handicap or even loss of life. Accident can lead to financial loss for recovering from ailment and also an accident victim losses his confidence level of working.

To an organisation, an electrical accident can cause, loss of skilled workman, delay in completion of work, financial loss by payment of compensation, facing of judicial procedures etc.

## Reason for Accident.

An Electrical accident can happen because of, unsafe environment, unsafe act or natural calamity.

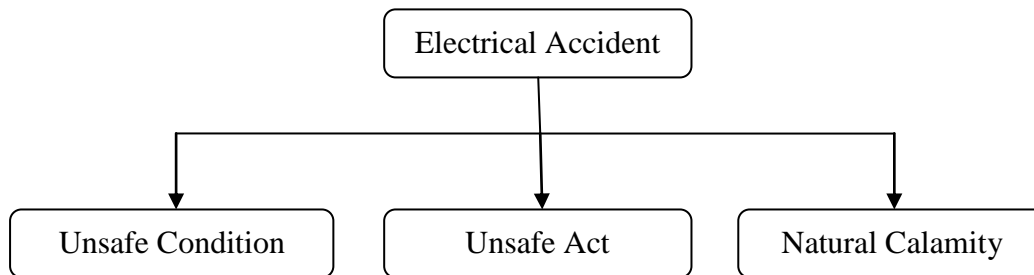

### Unsafe Condition :

Unsafe condition or work environment which causes accident includes the following.

- Working on corroded line poles or structure poles
- Working on poles without stay wire
- Working on lean poles.
- Lines / structures without standard ground clearances
- HT / LT Lines in a pole without standard clearances.
- Improper horizontal crossing of HT / LT line.
- Improper termination of cut points in LT line.
- Insertion / removal of a pole in an existing line without the arrangement of Temporary stay.
- HT/LT lines in a pole with LT supply from different HT supply and without a caution board
- LT line with separate street light supply from different transformer without a caution board.
- Return supply from improperly connected generator / inverter of consumer.
- Sag in conductor because of long span of pole.
- Line without strut / stay results in excess sag
- Non availability of guarding.
- Use of defective material such as poorly constructed scaffolding, broken ladder, torn gloves, old belt rope etc.
- Non standard design / construction practice of lines, structure etc.
- Improper earthing or non maintained earthing in structure, lines and switch yard.
- Control cable and power cable running together.
- Allowing a person to work at a height without the presence of any supervisor or co-worker.
- Improper illumination while working on a structure / outdoor / yard during night time.
- Non standard / heavy fuse provided in HG fuse or LT Feeder fuse.

## Unsafe Act :

Safety as a whole may be interpreted as the proper planning of work, proper usage of safety tools, following safety procedures and exercise of good judgement and intelligent supervision. Experience proves that majority of the accidents are preventable. Prevention of accident requires the whole hearted co-operation of all the employees of the organisation.

Accident do not just happens, it happens because of unsafe act of an employee or a group of employee carrying out a work. The following are the unsafe acts which may lead to an accident.

- Lack of knowledge on the existing incoming & outgoing supply, back feeding arrangements etc. All the employee working in an electrical system must be aware of the complete feeding arrangements and also must be aware of any changes in the feeding arrangements that has been carried out during his absence.
- Ignorance of safety procedures and negligence in usage of personnel protective equipments ( Hand gloves, Waist belt, Earth rod and Helmet).
- Over confidence in working. Working with confidence is very important in an electrical system but it must not be with overconfidence. Overconfidence will lead to work with negligence of safety concepts.
- Working with assumptions must be avoided. Any work must be started only after obtaining proper confirmation from the necessary authorities.
- “Failure to plan is planning to Failure” hence any job must be well planned and discussed with all the team members in order to gather all the required materials and safety devices in the work spot.
- Working following improper communication method like waving of hand, showing signs etc. A work has to be commenced only after proper communication and assuring the same through feedback.
- Working with urgency to complete a job.
- Working without properly isolating the work area from electricity, like working without opening AB switch, removing feeder fuses etc.
- Working without obtaining proper Line Clear (LC).
- Taking unsafe position or posture while lifting heavy material and failure to observe the surroundings while using a crane during construction / maintenance work.

- Distracting, teasing, horseplay, quarrelling or annoying in the work place.
- Usage of mobile phones during work time. Mobile usage may distract the concentration of a worker and hence it must be strictly avoided.
- Working with alcoholic intoxication must be strictly avoided.
- Working carelessly or without adequate training / knowledge in the procedure to work safely must be avoided.
- Throwing up or throwing down of hand tools while working in a height on lines or structure. All small tools must be raised or lowered by means of hand line and canvas bucket only. Men on the ground must wear helmet or stay clear of overhead work to prevent being stuck by falling objects.

### **Natural calamities**

Natural calamities are unpredictable and can cause damages to the public as well as properties. Natural calamities may be due to

- Heavy wind
- Heavy rain
- Flood
- Earthquakes

The above natural calamities may cause damage to the poles, conductor and all electrical equipments / installations.

### **Safe Working Procedure :**

In order to work safely in electrical system, the following procedures, popularly known as ABCDE of Safe Working shall be followed.

#### **A – Aware**

Before starting any work, the team which is going to carry out the work has to be aware of the following. It is necessary that all the individuals irrespective of cadre must be aware of it.

- ✓ Where to work.
- ✓ What is the nature of work
- ✓ Sources of Supply available at the work spot.
- ✓ Whether supply is under normal feeding or back feeding.
- ✓ Where to isolate
- ✓ Whether LC is required.
- ✓ Materials required for the work

- ✓ Time required for the work
- ✓ Brief description on the procedure to carryout the work safely and in an efficient manner

## **B – Break :**

We don't have a practice to work on live electrical equipments / circuits that could conveniently be de-energised. Hence breaking the supply to the work spot is an essential step to carryout safe working. Therefore it is necessary to

- ✓ Switch off the correct circuit on which the work has to be executed.
- ✓ If AB Switch has to be opened to break the supply, then proper gloves has to be worn and also it must be ensured that the Operating rod is earthed properly.
- ✓ If the work spot is away from the transformer structure then “Men at Work Do Not Close” board (In English & Tamil) has to be placed at the handle. In addition to that a lock may be provided at the handle to lock it in Open condition.
- ✓ If LC has to be obtained then it must be obtained by Foreman / Line Inspector after following the standard LC procedure defined in this manual.

## **C – Confirm :**

Any work has to be carried out only after proper confirmation and on receipt of permission from the concerned authority.

- ✓ If AB switch is opened to break the supply then it must be confirmed that all the three blades are completely opened and necessary clearance between the blade and contact is available.
- ✓ If LC is obtained then before commencing the work it must be ensured in the field that the supply has been interrupted only for their cause and not because of any faulty feeder trip / Load shedding / breakdown of any other equipments..
- ✓ Before commencement of work the field condition like proper clearances, any abnormal wire cuts etc must be observed and then only the work has to be started.

## **D – Discharge :**

Even though supply to a circuit has been interrupted, there will be stagnation of electric charge which will be sufficient to flash on an individual who comes into contact with it, hence it is necessary that after breaking a supply discharging has to be done safely.

- ✓ Discharging has to be done by using a standard discharge rod standing at ground level.
- ✓ Care must be taken to ensure that the discharge rod wire is atleast 0.75 m away from the body.
- ✓ The discharge rod shall be brought near to the circuit slowly and if any arcing or flash over is noticed then it shall be with drawn immediately.
- ✓ A report on such arcing / flash over shall be made to the person who issued the LC.
- ✓ Each & every one of the conductor shall be discharged as above.
- ✓ The leads used for discharging shall be tested for continuity before use and is of stranded flexible conductor instead of solid wire, preferably of copper.

## **E – Earthing :**

Earthing is a very important step which protects an individual in the event of any accidental charging of the circuit in which a work is carried on. But unfortunately it is noticed that many workers ignored to do earthing before commencement of work.

It must be clearly kept in mind that any work however small it may be, it has to be carried out only after proper earthing. The standard procedure of earthing is explained in chapter (11) of this manual, and this has to be strictly followed.

- ✓ Earthing shall be done on both the sides (incoming & out going) at the place of work.
- ✓ Short circuiting shall not be treated as a substitute for earthing and standard Earthing rods shall be used.
- ✓ The earthing and discharging shall be done by an authorized person only.
- ✓ The earthing kit consists of 3 No wooden rods with clamps on top of each, designed for securing and holding tightly with the line or droppers. From each of the above top clamps leads are brought down and bunched together. These are connected directly to an earth pipe.

- ✓ If there is no earth nearby, a temporary earth shall be provided by driving a metal conducting spike of depth atleast 3 feet.
- ✓ While removing the earthing, the earth rod shall first be removed from the spot and after all the earth rods are so removed, the connection to the earth pipe shall be removed finally.
- ✓ The earths shall be placed in such a manner that they will not be detached in advertently due to movements of men and other causes.
- ✓ In the case of lines meeting or crossing at any poles on which work is to be taken up, all the lines crossing or ending at this pole shall be earthed.
- ✓ Stay wires shall not to be used for the purpose of earthing.
- ✓ All conductors shall be treated as alive until they have been grounded properly.
- ✓ Earthing shall never be fixed or removed by bare hands.

## **General Instructions for Safety :**

### **Safety Manual :**

It each and every offices of Distribution and Sub Stations of TANGEDCO it must be ensured a copy of this Safety Manual is available (In English & Tamil). This must be made accessible to all the employees when needed. While conducting safety awareness programs the topics in this manual must be covered.

The Section Officer, Foreman & Line Inspector of a Distribution Office is responsible for implementation of Safety rules and procedures among the workers.

### **Smoking :**

Smoking must be strictly not allowed in the work premises especially when handling inflammable oils. Also smoking inside the battery room or carrying open fire torch inside the battery room must be strictly avoided.



### **Personal Conduct**

Drinking alcohol or consuming any type of intoxicants, while on duty is strictly prohibited. No employee shall while on duty be under the influence of such drink or drugs since it renders him incapable of discharging his duties properly and efficiently. If any employee found drunken during his duty hours then he shall be given punishment.

Employees shall be courteous and considerate towards public and towards each other. They should be disciplined particularly when engaged in work.

Employees shall not needlessly enter other area / places where they have no business unless permission to do so is first obtained.

Indulgence in jokes, mocking, betting, scuffling, flippant conversation and wrestling while on duty or off duty on Board's properties or in Board's vehicle is forbidden. Unnecessary talks shall be avoided and mind shall be focused on work.

### **Clothing :**

- Workers should not wear loose cloths they should wear clothing preferably uniforms suitable to the job being done.
- While working on live conductor do not roll up sleeves as dry cloth gives some protections against shock.
- Do not wear suspenders and arm bands with metal buckles or other metal parts, these might come in close proximity to live parts and may cause injury.
- Workers should not keeps any items like mobile phones, watches, valuable items etc in their pockets while working in heights as they may distract the concentration.

### **Lifting of Loads**

- No attempt shall be made to lift the loads beyond their capacity and employees should avoid twisting or excessive bending when lifting or setting down load.
- .Pushing should be resorted to when moving a load horizontally, rather than pulling.
- No one shall stand or pass under any suspended load being handled by a crane.
- Most lifting accidents are due to improper lifting method rather than lifting too heavy loads. When lifting heavy loads the back should be kept close to vertical and the lifting done with leg and arm muscles rather than with back muscle.
- Whenever and wherever possible accessories such as block tackles, jacks, bars etc shall be used instead of lifting by hand.
- It shall be checked whether all the required tools and tackles are in good working condition before taking up the work. Only proper tools shall be used for each job.



- Each tool must be visually inspected before and after use. Defective tools shall be rejected.

### **House keeping**

- The place of work, both within the building and around the work area in switch yard, should be kept neat and clean.
- Handling and usage of flammable liquids, oils, cleaning solvents should be carried out as per the prescribed manner so that they will not become the potential source of fire hazard.
- Pathways, stairways, fire escapes surrounding area near the distribution boards, control panels etc and all other passage ways shall be kept clear from all obstacles.
- Fused tube lights, bulbs and broken insulators must be safely disposed off without causing any injury.
- Each workman shall be responsible for leaving his work area clean and tidy.



### **Physical fitness**

Any employee who is unable to perform his duties due to illness or other disability shall promptly report his condition to his immediate supervisor.

Any employee who is mentally stressed and in disturbed manner due to any personnel problems, should inform it to their supervisors and refrain themselves from sensitive jobs.

## **SAFETY – ROLES & RESPONSIBILITIES**

Success of any plan / method depends on the way in which it is implemented or enforced, hence an enforcement mechanism to develop safe working habit in the minds of each and every employee must be chalked out and put into practice.

Though many instructions were given periodically to avoid accident, the number of accidents (departmental / non departmental) is in an alarming figure, therefore Roles and Responsibilities at each level must be clearly fixed and any deviation must be strictly handled

The roles & responsibilities at each level of distribution wing of TANGEDCO is described below.

### **Safety Committee :**

- At the corporate level a Safety Committee headed by The Chief Engineer / Planning must exist.
- The Safety Committee has to ensure effective implementation & monitoring of the steps taken to create safe working environment and to reduce the accidents / near miss incidents. Also to have close monitoring and analysis of the accidents, if occurred, and avoid recurrence of the same.
- The Committee must conduct a safety review meeting once in every six months along with the Regional Safety Officers and discuss regarding the important accidents that happened in their Region and to discuss the ways by which it can be avoided in the future.
- Necessary Safety Instructions and procedures as required from time to time has to be issued by the Committee.
- The Committee has to ensure the availability of the Safety Manual right from the section level.
- The Committee must conduct a periodic review on the content of the Safety Manual and it is responsible for the correction / updation of the manual.

### **Regional Level :**

Each and every Distribution Region of TANGEDCO must have an Electrical Safety Officer in the cadre of Assistant Executive Engineer / Electrical. The Safety Officer must be familiar with distribution safety aspects, provisions in Act, Regulation etc. His roles and responsibilities are as follows.

- Inspecting officer of all the apparatus of distribution network regarding safety.

- Any accident in his Region must be investigated by the Safety Officer and reports in the prescribed format must be prepared and submitted by him to concerned authorities.
- Ensuring the supply of quality PPEs (Earth rods, Rubber Gloves, Waist belt, Helmet & Uniform) to all the employees in his Region.
- Conducting safety awareness programs periodically in his region and motivating the staff towards accident free environment.
- Has to ensure that a copy of safety manual is available in all the section offices under his jurisdiction.
- Conducting surprise inspections in the Distribution circuits of section offices and associated sub stations to conduct safety audits. Any alarming unsafe conditions if noted must be reported to Superintending Engineer of Electricity Distribution Circle and correctives measures taken in this regards must be followed up.

### **Circle Level :**

Each and every distribution circle must have an Assistant Safety Officer in the cadre of Assistant Engineer / Electrical. The Assistant Safety Officer must be familiar with distribution safety aspects, provisions in Act, Regulation etc.

The Assistant Safety Officer (ASO) must be exclusively posted for safety related work and no other additional works must be clubbed or assigned to him. The Assistant Safety Officer will be reporting to Assistant Executive Engineer / Safety of that Region and under the Administrative Control of the concerned Superintending Engineer / EDC. His roles and responsibilities are as follows.

- Must Inspect all the apparatus of distribution network regarding safety within the jurisdiction of that circle.
- Must conduct surprise inspection in any work spot and ensure that all the workers are following safety measures while carrying out a job. If any lapse is noticed then necessary corrective instruction to be given and the concerned Foreman / Line Inspector must be informed about the violation and they must be instructed not to repeat such a mistake in future.
- While conducting surprise field inspection of a work spot, if any worker, Foreman / Line Inspector found to violate safety procedures then the ASO can stop the execution of any work which in his judgement is unsafe and may result in injury to any person and he shall also remove the employees or contract workers from the site, if they are found not using PPE or in unsafe practice or procedure.
- While conducting inspection if any unsafe condition like lean poles, damaged poles, damaged structure poles, overhead lines without proper ground clearance or with heavy sag, messy dangerous wiring, bare conductors, open pillar boxes etc

is observed then a notice in duplicate may be prepared and given to the concerned section office with a copy to Superintending Engineer / EDC. The same may be recorded in his register and rectification done in this regard may be followed up.

- The ASO must also inspect the sub stations pertaining to TANGEDO in his circle at periodical interval and ensure the following
  - ✓ proper house keeping
  - ✓ availability of usable fire extinguishers
  - ✓ proper methods followed in issuing Line Clear
  - ✓ availability of PPEs etc.
- Conducting safety awareness programs periodically in his circle to impart proper safety training and shall also create safety awareness among the employees.
- Any accident that has happened in a circle must be investigated by the ASO and report must be given to Safety Officer of his Region.

### **Division Level :**

- The Divisional Engineer / O&M has to ensure that safety is strictly followed without compromise while carrying out work in the field. Any unsafe act or unsafe condition must be seriously viewed by him and suitable corrective measures must be taken then and there.
- The Divisional Engineer must ensure that quality PPE are made available to all the employees of his division
- The Divisional Engineer must conduct safety awareness programs periodically in his division to impart proper safety training and shall also create safety awareness among the employees.
- The Divisional Engineer must see to that each and every employee of his division attends atleast ten hours of training session per year covering the following topics.
  - General safety awareness
  - First aid
  - Emergency procedures including shock treatment
  - Use of personnel protective equipments
  - Safety precautions while handling electro-mechanical equipments
  - Use of different types of fire fighting equipments
  - Responses in the event of emergencies including fire, flood, landslide, earthquake , etc
  - Site specific hazards and the precautions as well as response in respect of the same

### **Sub Division Level :**

- The Assistant Executive Engineer / O&M has to ensure that safety is strictly followed without compromise while carrying out work in the field. Any unsafe act or unsafe condition must be seriously viewed by him and suitable corrective measures must be taken then and there.
- The Assistant Executive Engineer / O&M is responsible for the safety aspects of all the TANGEDCO substations within his purview. PPE for sub stations and availability of charged fire extinguishers etc must be ensured by him.

### **Section Office Level :**

- The Assistant Engineer / O&M has to ensure that safety is strictly followed without compromise while carrying out work in the field. Any unsafe act or unsafe condition must be seriously viewed by him and suitable corrective measures must be taken then and there.
- Assistant Engineer / O&M is responsible for implementation of safety in his section
- In the normal working hours, any field work must be assigned only through the concerned Foreman / Lineman. This is to ensure that they are aware of the works that is going in the section and adequate safety measures are followed by them.
- Work allocation given must be clearly noted in a register with all details.
- Reasonable time must be given for a job to be completed.
- To the extent possible worker must not be permitted to attend multiple shifts in a day especially in field work.
- The Assistant Engineer / O&M must conduct safety awareness program every month without fail to impart proper safety training and shall also create safety awareness among the employees.
- A Safety Class register must be maintained and signature from all the employees who have attended must be obtained in the register. A group photograph in a normal mobile phone can be taken and a black and white / colour printout of the photograph has to be pasted in that register as proof for attendance.
- During this safety programme, all the employees must be directed to attend with their PPEs. The healthiness of PPEs available with the field staff shall be checked and action may be taken to replace the defective ones.

### **Responsibilities of Foreman / Line Inspector at Section Office :**

- The Foreman (Foreman, Foreman I Grade, Foreman Special Grade) and Line Inspector are responsible for implementation of safety in that section office and they must ensure that the workers follow safety instructions and procedures in each and every job they are taking up.
- They shall assign a work to sufficient number of qualified men.
- They must assign a job to a worker taking in to account of their physical and mental stability.
- They shall exercise or provide adequate supervision over the workmen at all times.
- They must ensure that the worker always carry safety equipments with them and use them in all the work that they are carrying out.
- They must ensure that safety procedures are followed while working.
- They must avail Line Clears (LC) if required for a job and ensure all safety precautions being followed while obtaining LC. The LC must be properly closed by them after completion of work.
- They shall follow up the work with the workmen, to ensure that they are approaching the correct location of work and the circuit is isolated.
- Any near miss while carrying out work must also be reported to the Assistant Engineer and possible steps must be taken to avoid it in future.

### **Lapse in Safety :**

- Any lapse in safety noticed by concerned officer must be viewed seriously.
- Action deemed fit as per standing instruction / Service Regulation has to be initiated against the erring individual without fail.
- Action against any employee who is intoxicated with alcohol during his duty hours must be taken without fail.

# ELECTRICAL PERSONAL PROTECTIVE EQUIPMENTS & TOOLS

Electrical Personal Protective Equipment (PPE) are equipment designed to protect workers from electrical hazards while working on electrical equipment and construction sites. Employees who work in construction / Operation & Maintenance of Sub stations, lines, power stations, machines and equipments etc must be provided with appropriate electrical PPE and be knowledgeable in the selection, use, limitations, inspection and maintenance of PPE.

Every employee must be ensured that he is provided with proper PPE and also he uses it while working to ensure his safety and the safety of co-workers. A register must be maintained in the Section offices for issue of PPE by the officer in charge for the work.

The following are the minimum requirement of safety devices & specific tools / Personnel Protective Equipments having ISI mark that has to be provided.

- Helmet
- Goggles and Eye Shields.
- Rubber Hand Gloves
- Safety Belt ropes
- Protective Clothing
- Safety Shoes
- Discharge Rod
- Earth Rod

## **Helmet :**

To effectively reduce the risks of head injury, an appropriate type of safety helmets should be provided. Helmet is required in the work places

- where there is a possibility that a worker may be struck on his head by a falling or flying object;
- where a worker may strike his head against a protruded object or may be struck by a swinging object.

The safety helmet selected should satisfy certain performance requirements including shock absorption, resistance to penetration; and be adjustable to fit and make comfortable to the user. Certainly, the safety helmet can never be effective unless it is properly worn for the purpose.



Helmet of good quality should be required for tasks than can cause any force or object falling to the head. When performing head protection safety checks, ensure that there are no dents or deformities on the shell and connections are tightened inside. Do not store in direct sunlight and always replace a hard hat if it was used for any kind of impact, even if damage is unnoticeable.

Safety helmets should satisfy certain performance/test requirements, including resistance to penetration, shock absorption, electrical insulation, resistance to flame and various working temperature, etc. Each design should have its own specifications to suit the working environment and the work to be done. A suitable safety helmet will mean one which is conforming to **Indian Standard 2925 : - Specification for Industrial Safety Helmets**

## **Face and Eye Protection**

PPE includes safety goggles and face shields and should be used for tasks that can cause loss of vision and an eye, burns, splashes, sprays of toxic liquids etc. Goggles or eye shields should be worn while performing the following operations:

- Welding and burning:
- Using grinders, jackhammers, pneumatic tools, chisels, shapers and drills;
- Painting and scraping
- Brushing or blowing machines for cleaning;
- Operating switches on load.
- Handling acids, strong alkalis in the battery room.





When conducting equipment safety checks, ensure that there are no cracks or deformities on the lenses, ensure the strap is in good working order and is firmly sealed to the cheek and forehead. A Safety goggles should conform to the **Indian Standard 5983 : - Specification for Eye Protectors.**

### **Hands Protection**

Rubber gloves that have been tested to atleast 10,000 volts should be worn when work is performed on, or within reach of, energized conductor and/or equipment. The rubber gloves should be available to all employees working in substation operations and maintenance and field staffs working on HT/LT lines, Distribution transformer etc.



**Gloves  
For Voltage Not Exceeding  
650 AC**



**Gauntlet  
For Voltage Exceeding  
650 AC**

The specification PPE includes safety gloves and should be used for tasks that can cause hand and skin burns, absorption of harmful substances, cuts, fractures or amputations. When inspecting hand protection equipment, ensure that they fit perfectly with no spaces and are free from cuts, burns and chemical residue. Always replace them if any sign of contamination was observed.

## **Inspection of Rubber Gloves**

Before rubber gloves are used, a visual inspection and an air test should be made. Inspection is required to be done daily prior to use and as many times during the day of use you feel necessary.

### **Visual Inspection**

When inspecting rubber gloves, stretch a small area at a time, as shown in Figure checking to see that no defects exist, such as:

- Embedded foreign material
- Deep scratches
- Pin holes or punctures
- Snags or cuts
- Unusual discoloration
- Burns



Look for signs of deterioration from age such as hardening and slight cracking. Also, if the glove has been exposed to petroleum products, it should be considered suspect because of the deterioration caused by exposure. Gloves that are found defective should be replaced. Never leave a damaged glove around for any other purpose; someone may think it is a good glove and not perform an inspection prior to using it.

### **Air Test**

After visually inspecting the glove, other defects may be observed by applying the air test as follows:

1. Hold the glove with thumbs and forefingers, as shown in Figure .



2. Twirl the glove around quickly, or roll down from the glove gauntlet, as shown in Figure below.

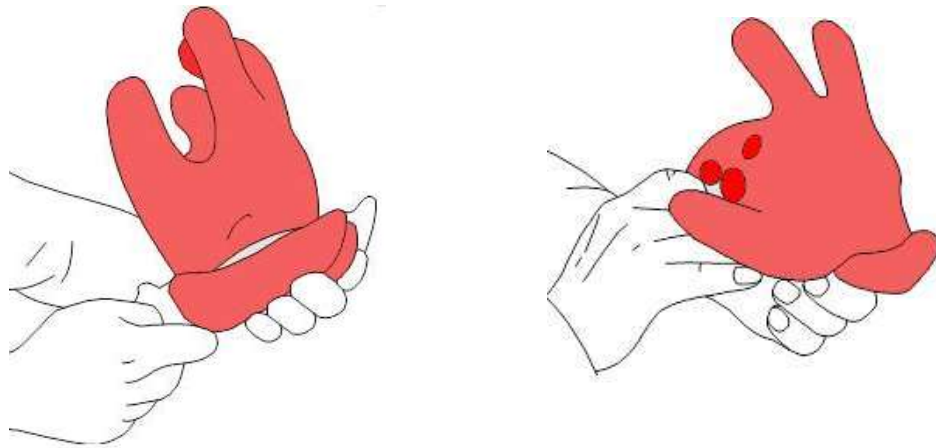

3. Trap the air by squeezing the gauntlet with one hand. Use the other hand to squeeze the palm, fingers, and thumb in, looking for weaknesses and defects, as shown in Figure above.
4. Hold the glove up to your face and ears to try and detect any escaping air.
5. If the glove does not pass this inspection, it should be destroyed and replaced.

#### **Maintenance of Gloves:**

- Gloves / Gauntlet has to tested for its insulation resistance, In an electrical laboratory at an interval not exceeding six months in accordance with **Indian Standard – 4770**.
- Rubber equipment shall not be folded or allowed to come in contact with sharp objects.
- Rubber equipment shall not be exposed to oil or grease or sun when not in use.
- Rubber equipment shall be kept clean. French chalk shall be used as preservative for storage of safety gloves.
- Rubber deteriorates under high temperatures. As such it is preferable to store rubber equipment in cooler places after drying when wet.
- Rubber equipment shall not be stored near batteries or acid stores and near live apparatus, i.e. where ionization or corona may be present, as this causes rapid deterioration of rubber.

#### **Safety Belt Ropes**

Safety Belts should invariably be used in all cases while working on overhead system, above two meters, like HT/LT lines, Structures, sub-station equipments etc. The belts may

be equipped with leather straps or pockets for carriage of tools. Chains and wire hooks shall not be used for this purpose.

The following procedure shall be observed for inspection and maintenance of Safety harness:

- No changes and alterations (including punching of extra holes) shall be done.
- Belts and straps shall not be dropped or thrown from an elevation.
- Belts and straps shall not be exposed to heat. These belts shall be kept out of range from blow torches, furnaces and other sources of heat or sharp objects.
- Belts and straps should not be allowed to come in contact with sharp objects, batteries and acids.
- Belts and straps shall be wiped with clean rag after work in rain and then allowed to dry at room temperature and periodically treated with castor oil to prevent its becoming hard.
- Employees using the safety belts shall be fully conversant with proper and correct method of wearing and removing of belt.
- Safety Belt should be checked for its wear and tear before and after each use.
- Safety Belt should not be used after its recommended use period as mentioned by the supplier.



Safety belt that is to be used while working in HT / LT Poles

Safety harness that is to be used working in heights

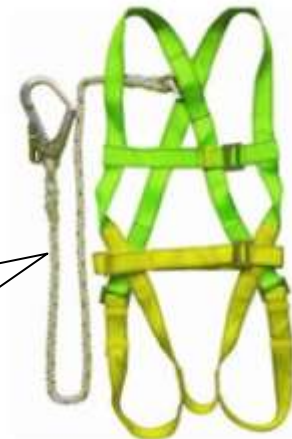

## Protective Clothing

An individual who is going to be working in a substation should dress accordingly. The wearing of synthetic fiber clothing should be avoided. These types of materials tend to melt when exposed to high temperatures and will actually increase the severity of a burn.

Cotton clothing is appropriate type of clothing. Employees who are working in public roads must wear reflective protective jackets



### Foot Protection

Safety boots should be used for tasks that can cause serious foot and leg injuries from falling or rolling objects, hot substances, electrical hazards and slippery surfaces. Use boots with slip-resistant soles that protect against compression and impact.

### Discharge Rod

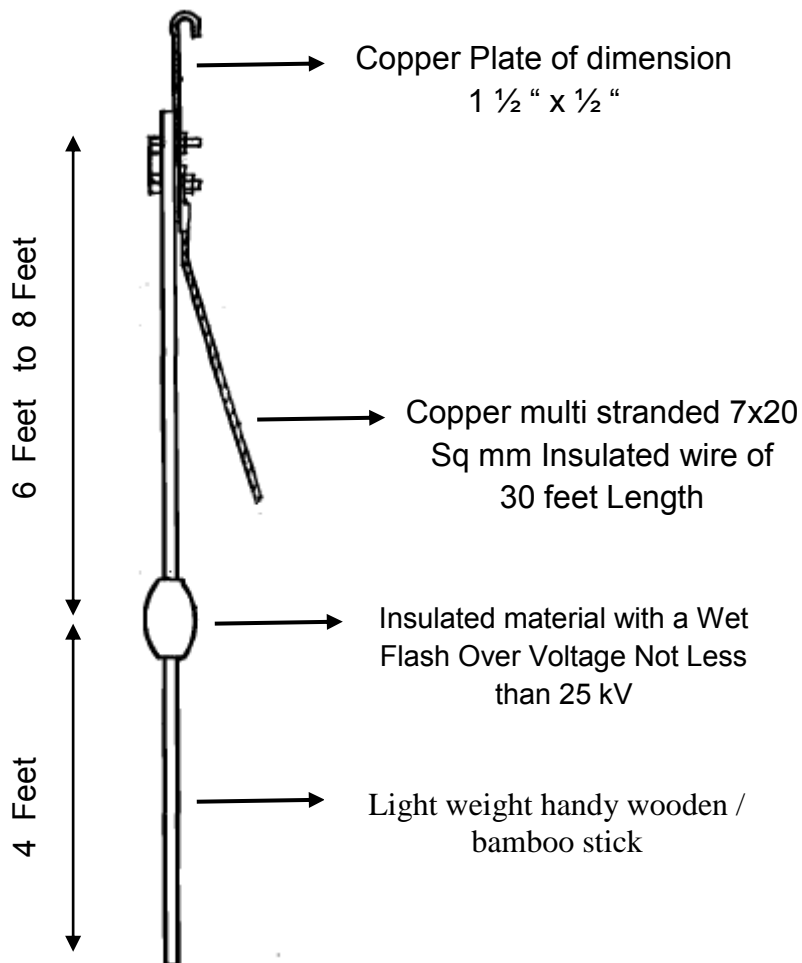

- The discharge rod shown above must be readily available in all Sub Stations and with the team working with HT lines.
- The discharge rod shall be used to discharge the stagnant electric charge in a deenergised line, before commencement of any work.

## Earth Rod

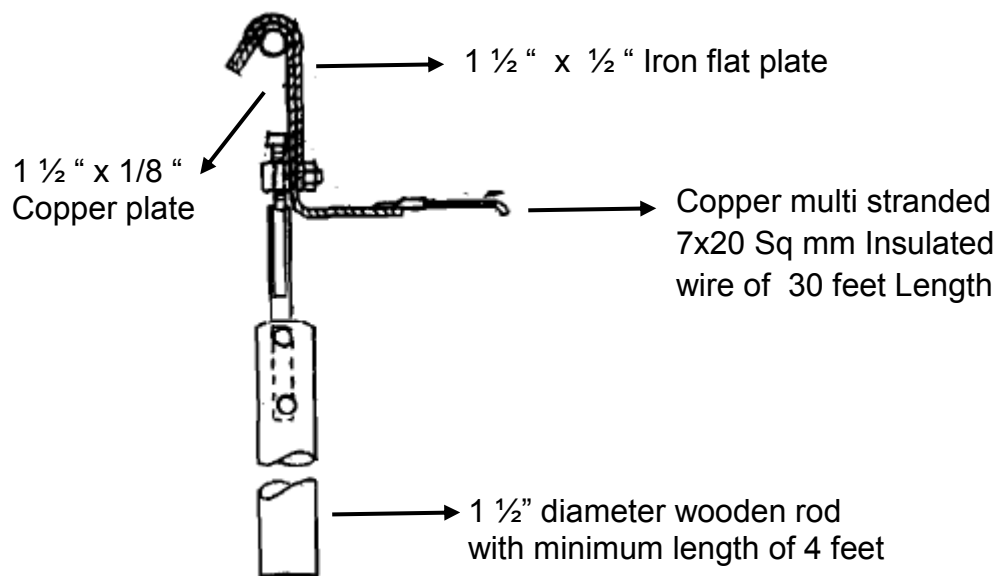

- The earth rod shown above is an important protective tool which must be properly used before commencement of any line work.
- The proper method of usage of Earth rod is detailed in chapter 11 of this manual.
- Each and every field worker must ensure that before proceeding to any field work he carries with him a set of three well maintained earth rods.
- The earth rod wires must not have any joints and the wire has to be handled properly while carrying and storing to prevent damage to the insulation of the wire.
- A physical examination of the wire has to be often conducted often to ensure that the insulation is in good condition.

## Ladders

- All portable ladders shall be equipped with non-slip bases and care shall be exercised in placing and blocking or lashing or having the ladder held by someone especially upon oily, metal or concrete surfaces.

- The bottom of the ladder shall not be kept away from the wall more than one fourth of the length of the ladder.

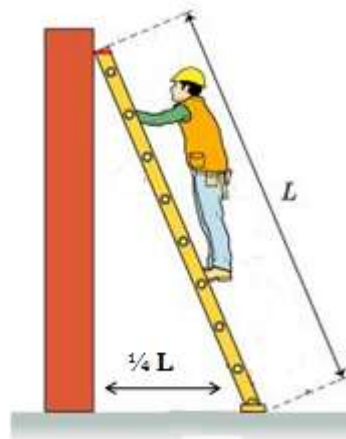

- Ladders should not be placed on an uneven surface or on any table, barrels etc. It must be placed on flat non slippery ground only.



- While going up or down a ladder, always face the ladder and use both hands. A three point contact with the ladder has to be made. Also it must be ensured that while climbing up / down the ladder no tools must be carried in hand / pockets.

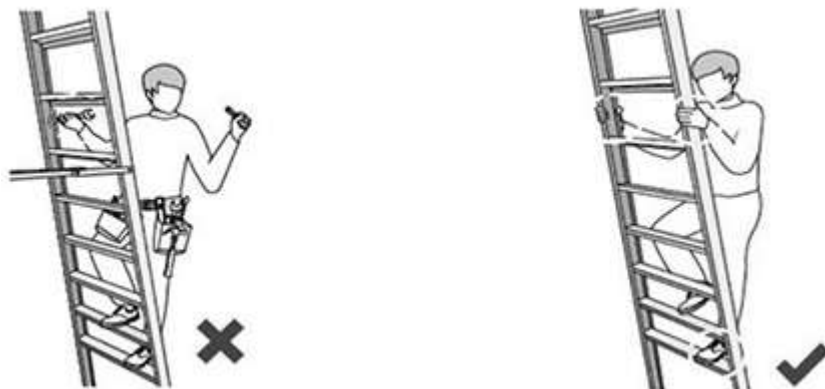

- Ladders shall not be placed in front of doors or windows opening towards the ladder, unless doors or windows are locked.

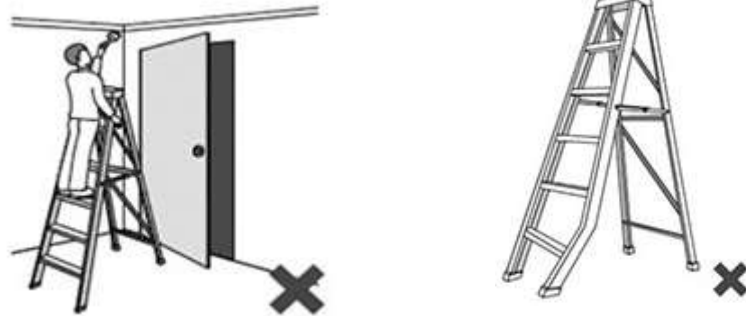

- Ladders, when fallen or struck, shall be carefully inspected for possible damage, ladders with weakened, broken or missing steps or otherwise defective, shall not be used.
- Wooden ladders for outdoor use shall be given a suitable coating of clear varnish or linseed oil or bituminous paint. Metallic paint shall not be used in wooden ladders.
- Portable ladders shall not be used in sub-station or switching station containing exposed high voltage conductor without the authority of authorized person. All portable ladders when used in a sub-station shall be locked to suitable anchorage when not in use. Portable ladders shall not be used in the vicinity of live parts.

## Hand Tools

- Employees shall use the right tools for each job and tools, which develop defects while in use, shall not be used until the defects have been rectified.
- Keep the tools in good condition with regular maintenance.
- Hammers with half broken or damaged handle must not be used. The handles must be replaced and maintained properly.
- Screw drivers should not be used as a chisel.
- When working on LT network or near live LT network long screw drivers without insulation or pliers with damaged insulation should not be used.
- Tools must be properly stored when not in use and not to be kept scattered all-around.
- Portable electric tools shall be equipped with 3-wire cord having the ground wire permanently connected to the tool frame and means for grounding the other end. Portable hand lamps shall be equipped with proper guards. The lamp holder shall not be in metallic contact with the handle and the guard.



- The extension cords shall not be dragged over sharp or rough surfaces or subjected to pressure by passing vehicles or material over them.
- Pliers, wrenches, etc., whether insulated or not, shall not be used without rubber gloves while working near live parts.
- Metal measuring taps and rules and tapes having metal threads woven in them shall not be used in the vicinity of live apparatus.
- Impact tools such as, chisels, punches, hammers and wedges with mushroomed heads shall not be used.
- Axes, shovels and similar tools shall not be used if handles are loose, cracked or splintered.
- Defective open and adjustable wrenches with spread jaws or pipe wrenches with dull teeth shall not be used.
- Pipe or other extensions shall not be used on wrench handles to increase the leverage unless the wrenches are specifically designed for such end extension.
- Only competent persons shall be allowed to handle blowtorches and fire pots.

# **SAFETY IN DISTRIBUTION CONSTRUCTION WORK**

This chapter deals with the general safety conditions that have to be followed while carrying out construction / erection activity of the following.

- 33/22/11 kV Substation and its associated equipments
- Distribution Transformer structure
- Overhead HT / LT Lines
- Underground HT / LT Cable

## **GENERAL REQUIREMENTS :**

Only good quality and materials as per BIS/ISS specifications, having more than adequate mechanical strength and the desired factor of safety for the supports and conductors as mentioned in the Safety Regulations, for construction of transmission lines and substations.

Using these practices would automatically avoid danger to the public and ensure Safety in the Construction.

- Regulation 12 of Central Electricity Authority (Measures relating to Safety and Electric Supply) Regulation 2010, General Safety requirements pertaining to construction, installation, protection, operation and maintenance of electric supply lines and apparatus:
  1. All electric supply lines and apparatus shall be of sufficient rating for power, insulation and estimated fault current and of sufficient mechanical strength, for the duty which they may be required to perform under the environmental conditions of installation and shall be constructed, installed, protected, worked and maintained in such a manner as to ensure safety of human being, animals and property.
  2. Save as otherwise provided in these regulations, the relevant code of practice of the Bureau of Indian Standards or National Electrical Code, if any, may be followed to carry out the purposes of this regulations and in the event of any inconsistency, the provision of these regulations shall prevail.
  3. The material and apparatus used shall conform to the relevant specification of the Bureau of Indian Standards or International Electro-Technical Commission where such specifications have already been laid down.
  4. All electrical equipment shall be installed *above* the Mean Sea level(MSL) as declared by Local Municipal Authorities and where such equipment is to be installed

in the basement, consumer shall ensure that the design of the basement should be such that there is no seepage or leakage or logging of water in the basement.

- OVER-HEAD EHV/EHT & HT/LT LINES, UNDERGROUND CABLES & SUB STATIONS (CEA REGULATIONS PROVISION):  
( Material and strength, Regulation 55 of CEA(measures relating to Safety and Electric Supply) Regulation,2010)
  - (i) All conductors of overhead lines other than those specified in regulation 68 shall *have* a breaking strength of not less than 350kg.
  - (ii) Where the voltage does not exceed 250 V and the span is of less than fifteen meters and is drawn through the owners or consumer premises, a conductor having an actual breaking strength of not less than 150 Kg may be used.
  
- Joints, (Regulation 56 of CEA(measures relating to Safety and Electric Supply) Regulation,2010
  - i. No conductor of an overhead Line shall have more than one joint in a span and joints between conductors of overhead lines shall be mechanically and electrically secure under the conditions of operation.
  - ii. The ultimate strength and the electrical conductivity of the joint shall be as per relevant Indian standards.
  
- Maximum stresses, factors of safety, Regulation 57 of CEA(measures relating to Safety and Electric Supply) Regulation,2010
  - i. The load and permissible stresses on the structural members, conductors and ground wire of self supporting steel lattice tower for overhead transmission lines shall be in accordance with specifications laid down, from time to time, by the Bureau of Indian Standards.
  - ii. Overhead lines not covered in sub-regulation(i) shall have the following minimum factors of safety, namely:
    - 1. For metal supports. 1.5
    - 2. For mechanically processed concrete supports. 2.0
    - 3. For hand moulded concrete supports. 2.5
    - 4. For wood supports. 3.0
  
- Conductors at different voltages on same supports" Regulation 62 of CEA (measures relating to Safety and Electric Supply) Regulation,2010

Where conductors forming parts of systems at different voltage levels are erected on the same support,the owner shall make adequate provision to guard against danger to linemen and others from the lower voltage system being charged above its normal

working voltage, by leakage or contact with the higher voltage system and the methods of construction and the applicable minimum clearances between the conductors of the two systems shall be as specified in regulation 69 for lines crossing each other.

Note :- Refer .Chapter -13 of this manual for standard clearances

- Routes -proximity to aerodromes, Regulation 66 of (EA (measures relating to Safety and Electric Supply) Regulation,2010

Over-headlines shall not be erected in the vicinity of aerodromes unless the Airport Authorities have approved in writing the route of the proposed lines as per relevant Indian Standards.

- Maximum intervals between supports, Regulation 67 of CEA (measures relating to Safety and Electric Supply) Regulation,2010

All conductors shall be attached to supports ,at intervals not exceeding the safe limits based on the ultimate tensile strength of the conductor and the factor of safety specified under regulations 57.

Provided that in the case of over-headlines carrying conductors of voltage not exceeding 650 V when erected in over, along or across any street the interval shall not without the consent in writing of the Electrical Inspector. exceed 65 meters.

- Condition to apply where telecommunication lines and 'Power lines are carried on same supports, Regulation 68 of CEA (measures relating to Safety and Electric Supply) Regulation,2010

i) Every overhead telecommunication line erected on supports carrying a power line shall consist of conductors each having a breaking strength of not less than 270 kg.

ii. Every telephone used on a telecommunication line erected on supports carrying a power line shall be suitably guarded against lightning and shall be provided by Cut-outs.

iii) Where a telecommunication line is erected on supports carrying a power line of voltage exceeding 650 V, arrangement shall be made to safeguard any person against injury resulting from contact, leakage or induction between such power and telecommunication lines.

- Lines crossing or approaching each other and lines crossing street and road, Regulation 69 of CEA (measures relating to Safety and Electric Supply) Regulation,2010

Where an over-head line crosses or is in proximity to any telecommunication line, the owner of either the over-head line or the telecommunication line, whoever lays his line later, shall arrange to provide protective devices or guarding arrangement and shall *observe* the following provisions, namely:

i. when it is intended to erect a telecommunication line or an over-head line which will cross or be in proximity to an over-head line or a telecommunication line, as the case may be, the person proposing to erect such line shall give one month notice of his intention so to do along with the relevant details of protection and drawings to the owner of the existing line.

ii. guarding shall be provided where lines of voltage not exceeding 33 kV cross a road or street.

iii. where an over-head line crosses or is in proximity to another overheads line, guarding arrangement shall be provided so as to guard against the possibility of their coming into contact with each other.

iv. where an over-head line crosses another over-head line, clearances shall be as under:

(Minimum clearance in meters between lines crossing each other).

Sl. No	Nominal System Voltage	11- 66 kV	110 - 132 kV	220 kV	400 kV	800 kV
1.	Low and Medium	2.44	3.05	4.58	5.49	7.94
2.	11-66 kV	2.44	3.05	4.58	5.49	7.94
3.	110-132 kV	3.05	3.05	4.58	5.49	7.94
4.	220 kV	4.58	4.58	4.58	5.49	7.94
5.	400 kV	5.49	5.49	5.49	5.49	7.94
6:	800 kV	7.94	7.94	7.94	7.94	7:94

provided that no guarding are required when line of voltage exceeding 33 kV crosses over another line of 250 V and above or a road or a tram subject to the condition that adequate clearances are provided between the lowest conductor of the line of voltage exceeding 33KV and the top most conductor of the over headline crossing

underneath the line of voltage exceeding 33KV and the clearances as stipulated in regulation 58 from the topmost surface of the road maintained.

**Precautions to be taken while making preparatory works for erection such as leveling etc.**

- Before taking up the work for preparation, It shall be ensured that the place selected is free from any UG cables, water pipe lines, Earthing pipes, Oil / Gas/ Chemical pipe lines.
- Rocky places may as far as possible be avoided.
- Under un avoidable circumstances, if any rocky area is selected and usage of explosives are warranted, suitable safety measures as prescribed below may be adhered to.

**EXPLOSIVES: Storage, Transportation, Handling & Use**

- All explosives shall be stored in dry condition in a waterproof permanent godown.
- The godowns shall be locked intact prohibiting entry of any un authorized person.
- A warning notice(with warning sign (**EXPLOSIVE- KEEP AWAY, DANGER**)) shall be displayed in a conspicuous place



- The Explosives shall be transported through a vehicle of sufficient cushion through springs such that it will not subject to jerk and friction and the speed of the vehicles shall not exceed 25 KMPH.
- Before drilling holes for filling the gap with explosives, it shall be ensured that no explosives are available in the existing holes and it shall also be ensured that all the explosives were exploded.
- After filling the explosives in the holes no drilling shall be done in the near by areas.
- A warning / caution shall be made to the public who are in access to the explosive area to stay away from such place to a safe distance.

- After explosion, the loosened soil / rocks shall be carefully removed away from there and persons engaged in the above work shall wear, protected shoes, helmets and life line rope etc.
- Detonators for exploding dynamite are of two kinds ..( hose ignited by fuse known as blasting cap; those fired by electric current are known as electric blasting Caps.
- Only person who are qualified by training and experience shall be permitted to handle, use or transport explosives.
- Dynamite and caps shall be stored in separate containers duly marked. While transporting dynamite and caps shall be placed in separate locked containers such containers will be kept as far apart as possible but not less than 3fts. (100cm.)
- All surplus explosive shall be returned to magazines as soon as possible following completion of a job.
- The area within 28th feet (9Mtrs) radius of Magazine shall be kept free of flammable debris and magazines floors shall be kept clear.
- Smoking and open flames are prohibited within 50 feet (15Mtrs) of any magazine or explosive.
- Trucks carrying explosives must not be left parked in congested areas, or subjected to major repairs.
- Smoking and open flames are strictly prohibited within 50 feet of explosives.
- Explosives, either in containers or otherwise shall not be thrown from trucks, slide along floors or handled roughly in any manner.
- Do not keep the explosives exposed to direct rays of the sun for a long time.
- Do not leave dynamite, lighting, explosives and caps unguarded.
- During approach and progress of a lightning storm, all handling and use of explosives shall he stopped and all authorized line staff shall seek a place of safety.
- Do not leave explosives empty cases or lining papers lying around where they are accessible to *livestock*, since animals may eat them and be poisoned.
- Deteriorated *explosives* should be destroyed by methods recommended by the manufacturer. They should neither be thrown into streams or bodies of water, nor buried in the ground.

## EXCAVATIONS

1. Proper and adequate timber shoring and bracing shall be provided to prevent sliding or slipping of loose or unstable earth, rock or other material or caving in of excavation.



2. Under cutting of banks of trenches and other excavations shall be avoided.
3. Excavated material shall be dumped away from the edge of the *excavated* trench to avoid the slipping of excavation material into the trench.



4. Excavation shall be properly fenced to protect men and animals from falling in.
5. Warning sign shall be placed near the excavation to warn the approaching traffic and men. At night, red danger light shall be displayed at a conspicuous point near the excavation.





6. The following additional safety measures to be adopted while working in a sloppy terrain

- All work shall be done under the supervision of an experienced person.
- Loose soil / rock shall be removed then are there frequently.
- No person shall be allowed to work on a height above the working person.
- The person working on such places shall use life line waist belt rope and safety helmet compulsorily.
- If the pits are above 6 feet depth and easily accessible, then a barricade of height 2 feet shall be provided close to it.
- The trenches dug on the public places / places of easy approach shall be barricaded with Fluorescent DANGER Tape.

### **SCAFFOLDING**

- Scaffolding shall be carried out with wood of no defect and no notches.
- All scaffoldings shall be provided with adequate supports at appropriate locations.
- Trestle scaffolds shall not be more than 3 tiers and its working platform shall not be more than 15 feet height.
- Care must be exercised during dismantling of scaffolding and no objects shall be thrown down.
- If the working height is more than 5 feet, then it shall be provided with a ladder or stair. This shall be provided for each tier.
- If the scaffolding is for a long duration, then stairs made of wood and hand rails on both sides shall also be provided.

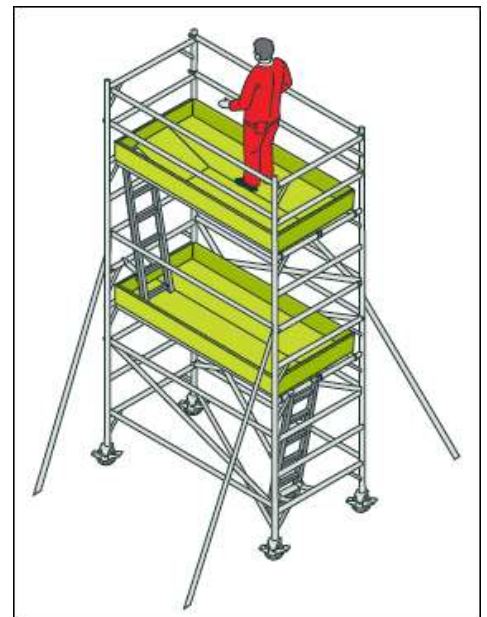

### **CONCRETING AND CEMENTING**

- If working at a height, the workers should use life lines or safety belts.

- Workers handling cement or concrete shall protect themselves by wearing rubber boots and rubber gloves as required.
- Proper guards and covers shall be provided on mixer gears, chains and rollers.

### **WELDING, BURNING, CUTTING (GENERAL)**

1. The primary hazards encountered during welding are Electric shock. Burns, radiant energy, toxic fumes, fire and explosions.

2. Avoid burns from electric arcs, gas welding flames, hot slag or touching welded parts before they become cool by the following precautions:

- Suitable goggles or welding helmets, safety welding gloves shall be worn for protection while welding. Barriers should be erected to protect other authorized line staff from rays of electric arcs or welding flames. Ultraviolet, infra-red and excessively bright visible light rays are injurious to eye.
- While doing welding works in structures / steel poles in line, it shall be ensured that no other persons are in physical contact with the structure / pole in which the welding works are to be carried out.



- Clean goggles should be worn while chipping the slag.
- Adequate ventilation shall be provided while welding in confined spaces or while brazing cutting or welding zinc, brass. Bronze, galvanized or lead coated material. Poisonous fumes may be generated during the welding process by metallic

oxides, coatings on the materials being cut or welded, or by the electrode or flux rod.

- While welding or cutting in elevated position, precautions should be taken to prevent sparks or hot metal falling on to people or inflammable materials.
  - Welding or cutting should not be attempted in dusty or gaseous areas where there is a danger of causing explosion.
  - Before welding or cutting a pipe, tank or container that has held flammable materials, drain it thoroughly out and fill the container with water or thoroughly wash the container with a caustic solution and spray sufficient carbon-tetrachloride into the container to fill it with non-explosive vapour.
3. Authorized line staff should avoid contact with the electrode or other live parts of electric welding equipments. Alternating currents (AC) are dangerous even at low voltage.
  4. In acetylene burning and welding, never allow oil or grease to come in contact with any cylinder, regulator, connection of gas welding equipment. Oil or grease in the presence of oxygen may cause a violent explosion.
  5. Never use matches to light a blow pipe. Use a friction lighter, stationary, pilot flame or other suitable source of ignition.
  6. All the welding cables shall be tested for insulation conditions periodically.

### **HANDLING AND STORING COMPRESSED GASES**

1. Cylinders containing acetylene. Oxygen, chlorine, hydrogen. Nitrogen, Carbon dioxide etc, should be stored upright in approved safe places where they cannot be knocked over and well separated from radiators, furnaces and combustible material.

2. Oxygen cylinders should be isolated from acetylene cylinders and gas filled cylinders separated from empty ones.

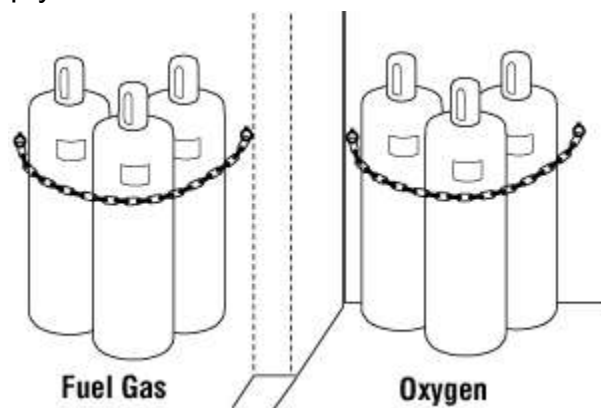

3. Gas cylinder should be protected from direct rays of the sun.

4. Empty cylinders should be plainly marked EMPTY and the valves closed.
5. Gases like Carbon dioxide, Chlorine have a tendency to settle down when released in air. They also diffuse very slowly. Therefore when working in manholes and basements, care must be taken to see that an accidental leak will not lead to suffocation. In such locations the gas cylinders should be placed away from the manhole openings or entrances to basements.

## **TRANSPORTATION**

### **GENERAL PRECAUTIONS**

1. Equipment should be kept in good operating condition and the vehicle should be driven in a safe manner so as to prevent injury to the authorised line staff and others.
2. Authorized line staff shall not operate a car or truck, unless he has the proper license in his possession.
3. Every driver of the car or truck shall be thoroughly familiar and comply with the State and city traffic laws covering the territory where he operates.
4. Confirm that the RTO Passing is done for the vehicle.
5. Labor carrier certificate (5 yearly) approved by RTO should be available..
6. Insurance shall be available and shall be in force
6. Test the brakes, clutch, horn and lights.
7. See that tyres are in good condition and properly inflated. The air pressure shall be maintained in such a way that it is neither excess nor low.
8. Check emergency equipments such as first aid kits, jacks and tools. Any equipment found missing or defective should be reported immediately.
9. Every driver shall report the vehicle's defect if any is detected.
10. Before filling the fuel tank, the motor should always be shut off. The hose nozzle should be kept in contact with the tank to avoid static sparks. Care shall be taken to avoid overflow / spilling of fuel from tank. While filling the petrol tank, smoking or using any open flame near the vehicle should be avoided.

## **DRIVING**

1. Most traffic accident can be prevented by faithful observation of three things.
  - a. 'Control speed', speeding is dangerous. A few minutes saved at the cost of an accident is no bargain.

- b. Avoid distractions. Give your undivided attentions to the job of driving. Keep your eyes on the road.
  - c. Drive defensively. Don't insist on your right of way. Try to anticipate the intention of other drivers and pedestrians. Their failure to observe traffic regulations does not justify your running into them.
2. Keep safe distance from the vehicle in front.
  3. Do not attempt to pass another vehicle going in the same direction unless you can plainly see far enough ahead to be sure you can pass safely. Proper horn signal should be given before passing.
  4. Do not drive to the right of the road Centre when approaching the crest of a hill, an intersection, rail road crossing or curve where full view of the roadway ahead is obstructed.

### **PARKING**

1. Park on the proper site on the street close to the curb or of the high way so as not to interfere with traffic.
2. When parking along a highway at night, parking lights shall be left ON but dimmed. If any work is to be done flares shall be set at opposite ends to warn other drivers.
3. When parking on a grade, place the vehicle in gear, set hand brake, turn wheels to curb or otherwise block the car so that it cannot accidentally roll.
4. To change a tyre or make other necessary repairs along the high way, pull over to the side of the road as far as possible.
5. Before leaving a parked vehicle, always remove the ignition key to prevent theft or unauthorized starting of the vehicle.
6. Leave or enter parked vehicle on the curb side wherever possible. Use extreme care if doors are on road side to see that no other vehicles are near.
7. Before starting a parked vehicle, observe front and rear to make sure that authorised line staff and objects are out of the way.

### **OPERATION OF TRUCKS AND TRAILERS.**

1. Before starting a truck, the man in charge of the party should carefully inspect the loading of material and see that wherever necessary, the material is secured safely and that all men are safely aboard.

2. Loadings of vehicles should not exceed their rated capacity and objects should not be permitted to be extended beyond the sides unless the necessary permit has been obtained from the Authorities.
3. The passengers carried in trucks should not exceed the legally permitted number

### **PROCEDURE IN TRAFFIC ACCIDENT**

1. Do not get involved in an argument as to who was responsible for an Accident, but Endeavour to get all facts in the case. Remember that accidents which may appear trivial often result in claims for authorized Line staff injury or property damage.
2. Do not lose your temper; try to be courteous and helpful.
3. Following instructions should be observed in the order given, if possible, when you are involved in a traffic accident;
  - a) STOP-Pullover to the curb or out of traffic, if possible. Never leave the scene of an accident without stopping to identify yourself and render such assistance as possible.
  - b) If the accident victim got severe injuries and no vehicle is available for shifting him to the nearest Hospital, dial 108 for emergency ambulance service. If 108 ambulance is also not available or getting late to arrive, then arrange for a private vehicle to shift him to the nearest hospital for first Aid within 10 minutes which is the golden hour to save the life of the victim.
  - c) Assist injured authorized line staff in so far as you are able, giving immediate attention to severe bleeding. Do not move seriously injured authorized line staff unless necessary for their protection against further injury. Send for doctor and ambulance, if necessary.
  - d) When requested, give your name, address company affiliation and show driver's license to the other party.
  - e) Secure name, address and license number of the other driver car license number and names and addresses of car owner and insurance company.
  - f) Record names and address of witnesses.
  - g) Unless some policeman is present at the scene of the accident, notify police having jurisdiction in the territory.
  - h) Sketch the location showing position of vehicles or pedestrians involved and any special conditions such as obstructions, parked cars, skid marks, show date, time of

day, weather and road conditions and any other information which you may consider useful.

- i) Notify your supervisor, and also submit written report with all useful information which you possess.

### **Precautions during rigging and hoisting by using cranes, derrick etc.**

- Man in charge of working party shall be responsible for loading within safe limit and by proper use of ropes, chains, cables, slings, jacks, skid and other hoisting and rigging apparatus. In no case shall such equipment be used until the supervisor has inspected on each occasion and assured that it is free from defects and safe for use.
- Before operating a crane, derrick, Chain pulley block and other hoisting equipment, the Operator should sound a warning and accept only one person's signal to start raising, lowering or swinging load. However, the operator shall stop immediately upon signal from any one.
- Employees shall familiarize themselves with the proper use of knots, ties and hitches and safe methods of hooking and slinging required in their work. Necessary training at periodical intervals and at induction level shall be provided.
- Particular care must be exercised to see that cables, chains and other hoisting equipments are not unduly stressed by improper use. All ropes, cables, chains, slings etc. shall be discarded when they are worn or have deteriorated to the point where their safe use may be questionable in the judgment of the supervisor / Safety Audit committee.
- Wire ropes or cable should have clips attached to cables; a sufficient number should be used.
- When applying U bolt clips to cables, a sufficient number should be used.
- Following precautions will preserve the strength and life of rope.
  - i) Do not drag rope on the ground unnecessarily as dirt chafes the fibres.
  - ii) Do not place kinked rope under stress.
  - iii) Do not tie knots where splices should be used.
  - iv) Do not allow ropes to become oil soaked, exposed to acid or corrosive substances.
  - v) Do not allow rope to remain exposed to weather any more than necessary.
  - vi) Carefully dry rope when it becomes wet.

## **TRANSPORTING AND STORING OF MATERIAL NEAR OVERHEAD LINES**

1. No rods, pipes or similar materials shall be taken below or in the vicinity of any bare overhead conductors or lines if they are likely to infringe the provisions for clearance under regulations 60 & 61 of CEA (Measures Relating to Safety and Electric Supply), Regulations 2010 unless such materials are transported under the direct supervision of a competent authorized line staff authorized in this behalf by the owner of such over-head conductors or lines.

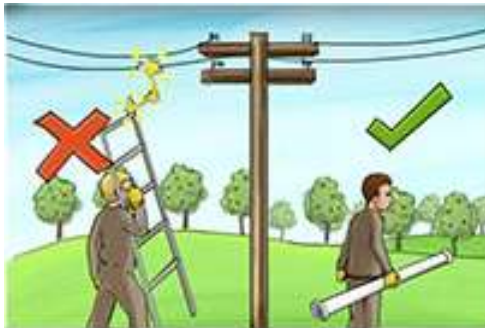

2. under no circumstances rods. pipes or other similar materials should be brought within the flash over distance of the bare live conductors or lines.

3. Loading and un loading of construction material underneath the live lines, by raising the dipper of the lorry shall strictly be avoided.

4. For loading and un loading of poles, equipments and other line materials, sufficient manpower / machinery shall be allotted to carry out the work.

### **Construction safety.**

#### **Transporting of materials.**

- 1) When the poles are being loaded no person must stand between the pole and the conveyance. Nobody shall stand or pass under a suspended load.





- 2) If the poles are to be transported on a flat type of trailer they shall be stacked neatly and fastened together tightly.
- 3) No person shall be allowed to travel on trailers loaded with poles.
- 4) Danger flags (red colour) shall be fixed at either end of the poles.
- 5) When unloading poles, no person shall stand on the unloading side.
- 6) During the course of transport of any equipment like transformers, etc, they shall rigidly be secured to the transport vehicle and packing material put on either side of the base of the equipment to prevent skidding. The loading shall be supervised by the competent authority.
- 7) No person shall be allowed to stand between the equipment and the sides of the transport vehicles.
- 8) While making turnings or going up or down inclines with loaded vehicles, very great care should be exercised in driving and over speeding should never be resorted to. The brakes of vehicles shall be specifically checked.
- 9) While transporting tall equipment, care should be bestowed for keeping the balance of the vehicle particularly at turnings.
- 10) When transporting particularly tall equipment, it should be ensured that there is sufficient clearance between overhanging branches of trees on roads and any telegraphic or other line and the top of the equipment (higher part of the equipment)

- 11) While transporting cable drums, it shall be ensured that the same shall be secured for its rigidity to prevent rolling down.

## **Erection work.**

- 1) Pole pits in sandy and collapsible soils should be shuttered and should not be dug much in advance of pole erection.
- 2) Warning 'DANGER' Boards should be exhibited on either side of the pits in inhabited areas.
- 3) Pits excavated on road sides in advance of pole erection shall be covered or suitably fenced before closing the works for the day, and before leaving the work spot.
- 4) During the erection of poles, the guy ropes shall be securely tied to temporary anchors like crow bars etc, driven to appropriate distance and the ropes are to be tightened to anchors, as the pole is being lifted into its position.
- 5) The slings lifting tackle etc, to be used in hoisting and erection of transformers and other equipment, shall be inspected and the officer in charge shall be thoroughly satisfied as to their mechanical strength in handling the weight.
- 6) While hoisting transformers on the D.P. structures, safety precautions by way of fixing additional clamps and bolts shall be taken and it shall be the responsibility of the person who is in charge of that work to ensure the same.
- 7) While working on the top of any structure the tools to the person working shall be tied through rope only and throwing of tools may lead to accidents, similarly after completion of work the tools shall be returned through a rope only.
- 8) While stringing conductors in any particular span which crosses another power line already in service, the following safety measures are to be taken
  - a) If the crossing is of two pole lines only, a line clear shall be obtained on the power line in service and then only the work shall be commenced.
  - b) If the line that is being strung goes under a tower line, adequate care & precautions shall be taken for anchoring the conductor that is being strung by passing a loaded rope over the conductor so that the conductor may not fly up, and reach the vicinity of the live conductors.
  - c) Similarly when a line to be dismantled, the loaded point (cut point shall be dismantled first by simultaneous provision of temporary stays in such a manner

that the pole shall not incline towards the other side due to the sudden removal of loaded portion.

- d) While dismantling the conductor from insulators, the conductors in the both extreme ends of the faces of the line support (say x arm) shall be removed, then only the conductors in the inner ends of the faces of the pole on the x arm shall be removed.
- e) While stringing the conductor it shall be through the drum only and not by pulling on road which may lead to the damage to the conductor.

### **General precautions**

- Whenever works are carryout by a contractor, the sole responsibility of safety of the working personnel working under him lies with the contractor. Agreements / documents shall contain the clauses fixing the above responsibility with the contractor appropriately.
- However the above works shall be supervised and intervened on shortcomings of safety.
- Whenever cables are laid it shall be properly jointed and well compounded.
- When cables are laid then appropriate depth on earth shall be maintained as per the table below.

<b>Voltage rating</b>	<b>Depth required ( minimum ) on road</b>	<b>Depth below railway track</b>	<b>Distance between Telephone cable</b>	<b>Depth below drainage</b>	<b>Min Dia of the pipe if the cable is laid through Pipe</b>
<b>LT</b>	<b>0.75 m</b>	<b>8 feet</b>	<b>1 feet</b>	<b>2 feet</b>	<b>10 CM</b>
<b>11KV</b>	<b>1.00 m</b>				<b>15 cm</b>
<b>33 KV</b>	<b>1.2 m</b>				<b>20 cm</b>
<b>110 KV</b>	<b>1.5 m</b>				

- When the DT structures are erected on Road side, then the operating pipe shall be kept erected away from the roadside.
- Care shall be exercised when DTs are erected near buildings, bridges or any infrastructure then it shall be ensured that no water flow due to rain water or overflow of water or passage of water shall come in contact with our structure or lines

- If it happens that due to increase in height of the road the clearances may become inadequate and hence it shall be given suitable height to meet the statutory clearances.
- When DTs are erected near the over bridges, then it shall be ensured that at no case the live parts are accessible from any part of the over bridge.
- No DT / Lines shall be erected inside any educational institution.

### **MANUAL HANDLING CARRYING , PILING etc OF MATERIAL AND EQUIPMENT**

- If possible, the materials in the work site must be carried from one place to another by ropes, jacks, rollers, wheel barrows and wheel carts.
- The workmen shall be trained in safe methods of handling. They shall avoid the following ;
  - ❖ Lifting with back.
  - ❖ Lifting too quickly and with a jerk.
  - ❖ Lifting while in an awkward position or with a poor footing.

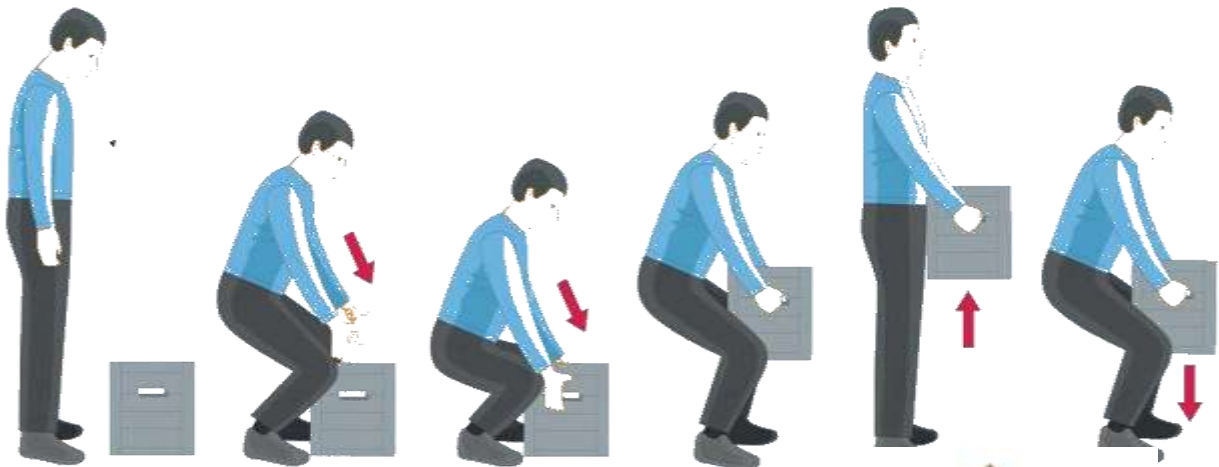

- ❖ Handling load which are too heavy or loads which obstructs vision.
- ❖ Handling loads with sharp edges or corrosive materials without the use of suitable protective clothing and equipment.
- ❖ Raising or lowering of heavy objects by two or more workmen shall be governed by a well understood code signals to ensure unity of action.
- ❖ Only light loads should be lifted with various sizes of poly propylene rope.
- ❖ These ropes should not be used over sharp metal edges.

## **MECHANICAL HANDLING OF MATERIAL AND EQUIPMENTS**

- Suitable hoisting apparatus should be used for hauling and carriage of loads above 500 Kgs.
- Slings for hoisting and other purpose may be made of chains, wire rope or fibre rope of sufficient strength to carry the loads.
- All slings should be provided with rings, shackles, links, hooks or I-Bolts of a proper size so that they could be safely suspended. All should have the same safe working load capacity.

## **HANDLING OF INSULATORS, CABLE DRUMS etc**

- The insulators should be packed in wooden crates and transported to the work site.
- Heavy objects and equipments should not be placed on the insulator crates.
- The insulator crate should be manually unloaded from the truck and carried to the work site.
- The conductor as well cable drums should be loaded and unloaded with the help of chain pulley block or mobile cranes.
- The conductor and the cable drums should be stored over wooden sleepers.
- Before the insulators are raised up, they should be inspected for any possible cracks or chippings. Only sound insulators should be installed.

## **STRINGING OF CONDUCTORS**

- The conductor or the cable drum should be supported on the drum support and the paying out of conductor/cable should be done by rotating the reels in a direction indicated by the supplier.
- The paying out of the conductor should be done carefully avoiding any kink formation, rubbing against stones and other hard surfaces.
- In stringing of the conductors across railway lines, scaffolding should be done on either side of the railway line to ensure that the conductors are not allowed to lay on the railway track at any time of the work.
- Every reasonable effort shall be made not to interfere with P&T Lines and public property.

### **PROVISION OF SAFETY CLAUSE IN THE CONTRACT:**

As per the provision in Clause No.7(1) of CEA (Safety requirement for Construction, Operation & Maintenance of electrical Plants and electric Lines) Regulation-2011, owner shall incorporate the safety provisions in the contract documents which are required to be complied by the contractor's employees during execution of the contract to facilitate safe working during execution of the work. As per the provision in Clause No.7 (2), Contractor or Sub-contractor is responsible for the Safety adherence of their workman at work place.

Foundation, brick

# **Safe Working in Sub-Station**

## **General Safety Instructions:-**

- All Substations must have a single line lay out with specific markings of Switches / isolators / Earth switches including earthing locations.
- All sub stations shall have approved Operating instructions specifically for that particular substation incorporating all Standard Operating Procedure including for emergency and disaster also.
- All the authorized personnel working in the Substation must be aware and conversant of the Standard Operating instructions and it shall be ensured by the concerned Engineer.
- All Substations shall have 2 key boards provided in an easily accessible and in the close vicinity of the authorized operating personnel. One is meant for housing keys which are normally in Service and the Other key board identical to this shall be meant for keeping the keys of the equipments / isolators / switches which are under Line clear / breakdown and it shall be with lock and key.
- A lay out of source / feeding points of the Substation shall be available including the location of switches / isolators / equipments in a conspicuous position.
- For fast and effective communication (in case of emergency), the following phone or / and mobile numbers shall be readily available and displayed in the Control room in a conspicuous position.
  1. Police station of concerned Area.
  2. Ambulance service.
  3. Govt. Hospitals (near to Sub station).
  4. Fire Station
  5. Electrical Inspector.
  6. Sub station in charge
  7. Security in charge
  8. EE / MRT & AEE / MRT concerned.

- Danger signs should be displayed to warn person, the presence of high voltage equipment as detailed below.
  - As per regulation 18 of CEA the owner of every installation of voltage exceeding 250 v shall affix permanently in a conspicuous position a danger notice
  - On all supports of overhead lines of voltage exceeding 650 v which can be easily climbed upon without the aid of ladder or special appliances.



- Gates in switchyard fences and doors to bus compartments and other enclosures containing live equipment including AB switches should be kept locked at all times except when authorized line staff are working inside.
- There must be a clearance of 5 feet, between the SS fence and the electrical equipment live point .The fence should be earthed at every 200 feet separately. Generally the fence earthing should not be linked with the SS Earthing. The iron gate in the SS fence shall also be earthed separately.
- Unauthorized person should not be allowed inside a hazardous operation area like a bus compartment, switchyard etc. unless such person is accompanied by a responsible authorized person who shall always be present while such person remains in the area. Any person deputed to clean the yard or parts of the plant in such areas must be given clear instructions and a responsible person must be present while the person is carrying out the work to ensure that the person does not endanger his/ her own safety.
- Access to enclosure within chambers, cubicles or cells containing live high and/or extra high voltage apparatus shall normally be provided with barriers and kept locked.



- No. person except an authorized person or a person acting under his immediate supervision shall have access to any enclosure, chamber, cubicle or cell in which a live conductor is exposed.
- Master key of the locks on all chambers, cubicles on switchgear shall be retained with the Authorized Person and the other keys with the operator on duty. Key Boxes fitted with locks shall be provided at suitable position for the retention of key.
- A key register shall be maintained wherein issue and receipt of all keys shall be entered and holders of such keys shall be personally responsible for its safe custody.

## **SAFE WORKING PROCEDURE**

### **Operations General Provisions:**

- All switching and other operations requiring engineering knowledge or skill shall be carried out by Authorized persons or competent persons acting under the immediate supervision of Authorized persons or competent persons.
- **The shift in charge shall not leave the SS premises in any case.**
- Except for agreed switching required in case emergency, no high voltage switching shall be carried out without the concurrence of the Competent Authority (System Operation/SLDC in case of Grid Sub-Station.)
- No high voltage earthing switch shall be operated or circuit main earth connection attached or removed except under the instructions of the Competent Authority (System Operation in case of Grid Substation).
- The following precautions shall be observed in relation to switching operations:
- High Voltage / Extra High Voltage apparatus shall be operated by using rubber gloves/gauntlets accompanied by another person for assistance for Operation and for emergency if any.
- When low or Medium Voltage fuses, which are not in series with a circuit breaker, are to be operated, the operator shall use rubber gloves, insulated platforms or PVC mats.
- When replacing a low voltage fuse, which is in series with the switch, the switch shall first be opened and confirmed.
- Where isolators are in series with circuit breakers the circuit breakers shall always be opened and confirmed that no current is flowing before opening isolators and

conversely when the circuit is being closed the circuit breaker shall be closed after closing the isolator.

- Any abnormality in the condition or operation of any switch shall be reported to the person in charge of switching operations immediately.
- Where there is interlock system to guard against irregular sequence of operation in switching, the failure of interlock shall not be taken as an excuse for incorrect operations.
- Following incidents and events shall be recorded promptly and accurately, in permanent ink on the Receiving Station/Sub-station. Operation Log Book and the Operator hourly Log sheet maintained for this purpose.
  1. All disturbances, interruptions to service or imposed restriction of load together with reasons thereof should be recorded as above.
  2. Particulars of defects observed or reported in the plant or apparatus taken out of services as a result of the same, operating errors etc.
  3. Particulars of major overhauls, repairs routine inspections.
  4. All instructions/orders relating to operations issued or received or relayed through the Receiving Station/Substation together with the identity of the parties concerned.
  5. All switching operations on High & Extra High Voltage switches, their timings and explanation of the reasons thereof.
  6. All clearance orders (i.e. Line clear-to-work, Sanction for test Station Guarantee, Self Protection tag etc.) received, issued or refused.
  7. Particulars relating to telephonic message in connection with operations on high and Extra High Voltage Switches.
  8. No entry on the log or register shall be erased under any circumstances. A wrong entry shall be cancelled by a single line drawn across it, so that it is not rendered illegible. The log sheet and the corrections thereon shall be signed and initiated by the Shift In charge.
  9. In case of telephonic instructions, the Shift-in-charge shall not take any action until he/she has recognized the person giving instructions and read back the message to confirm the accuracy of the same.

10. Before changing shift, the outgoing shift in-charge shall personally explain and record a summary of all conditions in vital matters requiring particular attention of the incoming shift in-charge. Incoming shift in-charge shall thoroughly understand the same before taking over shift.

11. The procedure for issue / receipt of Line Clear is detailed in Chapter 10 of this manual which has to be followed strictly.

### **Maintenance General Provisions:**

- Equipment wears out gradually and the efficiency may drop off almost imperceptibly day by day. These gradual changes in equipment performance can be determined only by systematic checking of the daily operation records and inspection/condition monitoring of electrical apparatus.
- All switch-gear shall be inspected and tested after every major overhaul or repairs at periodical intervals (at every shut down if possible) not exceeding one year, as follows:
  1. For cleaning of all parts and lubrication as far as possible in every shut down.
  2. Tightening of connections on wiring terminals, particularly those subjected to vibration;
  3. Checking condition of tripping, battery, fusible elements, indicator lamps, contacts and interlocks and effecting such replacements as may be necessary.
  4. Checking of relays, instruments and meters and effecting such readjustments as may be necessary.
  5. Entry holes for cable glands, dummy plates etc. shall be closed and sealed properly.
  6. All equipments and panels shall be vermin proof.
  7. The Maintenance Engineer shall prepare and maintain a suitable History Book of each item of apparatus under his charge. No person shall carry out any work including maintenance repairs or testing on or in the vicinity of any electrical apparatus unless;
- In the case of high and/or extra high voltage apparatus, the work is covered under a L/C to work or sanction-for-test or the emergency procedure and the safety requirements connected therewith have been complied.
- In the case of work on live apparatus on lines no employee shall work on or touch any exposed parts of any apparatus or live line except when using adequate and approved protective device.

- Rubber mats of adequate insulation strength should be provided on the places of operation near the Control Panels and the same should be kept neat and clean and it shall be moisture free.

### **Safety precautions for work place containing exposed live area**

- Before commencement of a construction or maintenance work in an energized Substation, L/C Permit shall be obtained from the authorised person and necessary precautions for safety of personnel shall be ensured.
- Adjustment, cleaning and painting of earthed metal enclosures and structures may be carried out from ground level by competent persons only, under a danger notice, provided specified clearances are maintained.
- Mobile cranes and derricks shall be effectively earthed when being moved or operated in close proximity with energized lines or equipment.
- No person will be allowed to enter the switchyard with umbrella or any conducting materials in vertical position.
- Isolating of electrical apparatus should include;
  1. Isolation from all points from which it is possible for the apparatus to become alive (e.g. voltage and auxiliary transformers, common neutral earthing equipment).
  2. Locking of circuit breakers, isolators, control handles and safety device wherever such arrangements exist, in respective position.
  3. Locking of all enclosures leading into live sections from the work area to avoid wrong opening of doors.
  4. The section made dead for working should be only that section required for execution of the work and it should be defined by use of barriers, screens & danger Tags, etc., so that the minimum specified clearance are maintained. The section should be bound by safety ribbon & flags during day and red lights during night along with manila rope to be fenced around the area covered for work. Red flags shall be provided for unsafe area during work in day time.
  5. While working on or near any exposed live parts, minimum clearances from the nearest exposed conductors to the place of work (e.g. ground level or working platform) should be maintained.

6. No material or tools should be carried on shoulders. Long material and tools should be carried in horizontal position and in a manner to maintain the applicable clearances. To



Following precautions should be observed in the **use of ladders and long objects in the work area inside the switchyard:**

1. Height of the ladders should be suitable for the work and not greater length than required for the work involved. These should be **transported horizontally** in the yard.
  2. Movement and erection should be subject to direct supervision of the authorized person.
  3. Portable ladders, when not in use, should be shrunk securely locked to a suitable anchorage.
  4. Portable ladders provided for giving access to fixed ladders, should be padlocked in position by an authorized person while work is being carried out on the structures.
- Number of accidents has taken place in switchyards which are partly commissioned and where extension works are under taken by Contractors. As the work site is in the close proximity of charged bays, therefore utmost care has to be exercised during erection of equipments and movements of materials, Tools & mobile crane etc. It is necessary to restrict entry & movement of contractor's men & materials in the charged areas of switchyard by barricading. Further, all erection works should be undertaken under strict supervision of Board engineers as well qualified Site Engineer from Contractor's side.
  - During Pre-commissioning checks on equipments in extension bays, Line Clear Permit should be taken prior to starting of work and engineer/staff should always be associated for such works. The Supervising engineer of BOARD (Construction or Maintenance) must avail Line Clear and should be present at the work site in these cases.

### **Work on remotely and/or automatically controlled equipment:**

- A Line clear-to-work shall be obtained for all work on Control Equipment and its wiring or Relays. Before work is carried out on remotely or automatically controlled equipment such as Circuit breakers, Isolators, Tap changing gear or Compressors, the automatic or remote control features shall first be rendered inoperative by selecting local / remote selector switch.

### **Work on equipment operated by or containing compressed air:**

- Line clear-to-work shall be obtained before start of the work.
- Work, other than operating adjustments, shall be carried out only under the following conditions:
- Operating adjustment on equipment operated by or containing compressed air, which require the normal air supply, may be carried out only when necessary and under the direct supervision of the authorized person.

### **Work in underground system:**

- No. person shall enter or be permitted to enter any underground chamber or other confined space in which dangerous fumes are likely to be present to such an extent as to involve risk of the person being overcome thereby unless
  - (a) It is provided with a manhole of adequate size or other effective means of access.
  - (b) A certificate in writing has been given by competent person based on a test carried out by himself, that the space is free from dangerous fumes and fit for person to enter, or
  - (c) The employee is wearing a suitable breathing apparatus and a belt securely attached to rope, the free end of which is held by a person standing outside the confined space.
  - (d) Open flames and smoking shall be avoided in under-ground chambers.
  - (e) Tools and materials shall be kept clear of the man-hole.

### **Work on transformer and oil storage tanks:**

1. Before an employee is permitted to enter any tank it shall first be adequately ventilated and if necessary, the process of ventilation shall be continued during the entire period of work.

2. When an employee enters a tank, another employee shall be directed to stay in the immediate vicinity to render any aid that may be required by the person working inside.
3. Transformers removed from service due to internal trouble are likely to contain poisonous and explosive gases in large quantities. These shall be properly ventilated before undertaking repair work.
4. Oil storage tanks shall, in addition to being ventilated, be properly purged and cleaned before any employee is allowed to enter the same.

### **Working on Transformer:**

- A Line Clear-to-work shall be obtained for all work on Transformers.
- For isolation purpose, both the primary and secondary voltage switches and isolators are opened and earth shall be done on work side. Similarly when isolating transformers, to which voltage transformers are connected, the voltage transformer shall be isolated and low voltage fuses withdrawn to prevent the possibility of transformer being made live through the synchronizing or voltmeter plug.
- The transformers shall be isolated from all common neutral earthing equipment from which it may become live. This does not require the disconnection of solidly earthed neutral or neutral equipment connected solely to the transformer on which work is to be done.
- Whenever transformer is replaced, the new transformer shall be checked carefully for voltage, polarity and phase sequence, before put into service.
- Transformers without conservators shall be treated as if the space above the oil level contains highly explosive gas and, therefore, the space shall be suitably ventilated before entering the tank, e.g., by keeping the manhole cover open for sufficiently long time or by circulating dry compressed air.
- Transformers which are provided with inert gas as a precaution against ignition of explosive gases in the space above the oil level shall not be entered until the tank has been ventilated with dry air or left open long enough to permit adequate natural ventilation.
- Open flames or inadequately protected portable lamps shall be kept away from the manhole and smoking shall not be permitted when working on or in the transformers.

- Persons working in transformers shall not carry any loose articles like key bunches, metal articles(Coins) in their pockets and persons working in or on the top of transformers shall not keep any loose tools around themselves, instead they must use Tool Holder.
- After the testing or Maintenance work done on the Transformer, it should be ensured that the tap position of transformer which is selected before the work carried out shall be same as per the other transformers operating in parallel.

### **Working on Circuit Breaker:**

A Line clear-to-work shall be obtained for all work on HT/EHT circuit breakers. For isolation purpose it shall be ensured that:

- a) Breaker is in open condition before opening respective isolators.
- b) Line and bus isolator have been checked open.
- c) There is no back-feed from potential transformers.
- d) Main fuses at the Control panel have been removed and DC voltage is disconnected from breaker mechanism.
- e) Tools and equipments are in safe working condition.
- f) When working on the mechanism with the breaker closed, block the trip latch so that it cannot be tripped accidentally.
- g) Be sure that auto-reclosure feature, if at all available, has been by- passed during maintenance work
- h) Isolators on both sides, control switches (or control fuses), relay trip blocking switches and compartment doors are open.
- i) After maintenance work is over, the breaker should be operated by relay operation as test check. This ensures safety of the system for future faults.
- j) Mechanical blocking, when necessary, to prevent unauthorized movement of the mechanism, installed.
- k) In case where there are no disconnecting switches between the transformer bushing and the circuit breaker, the transformers are isolated by removing the LV jumpers
- l) Circuit breakers, which have pneumatically operated mechanisms, shall not be blocked mechanically while the pressure remains in the breaker storage tank or tanks. Mechanical blocking may result in damage to the breaker.
- m) In multi bus / duplicate bus arrangements, supply from all the buses shall be isolated.



### **Additional precautions for work on Vacuum Circuit Breaker:**

- (a) Do not work on the interrupters or the mechanism unless the circuit breaker is in the “open” position and both the closing and opening springs are discharged and all electrical power is removed.
- (b) Do not allow anything to come in contact with the interlock roller on the right side of the mechanism.
- (c) Do not use contact separation that is less than the recommended open position breaker contact gap.
- (d) To measure the IR value of the internal circuit of breaker, the AC supply shall be disconnected and insulation Tester shall be used. . The measurement is made by connecting a 500 V insulation tester from the wire to Ground.
- (e) Do not attempt to remove or reinsert the vacuum interrupter in the interrupter support assembly.

### **Working on Switch Board Panels/Control Panels:**

- Line clear-to-work or sanction-for-test shall be obtained for all work on Switch Board Panel/Control Panel.
- The panel to be worked upon shall be differentiated from others by wrapping safety ribbon. Where the work is to be carried out both on the front and the backside, the red ribbon shall be wrapped on both side of the panel.
- The switchboard panel shall be discharged and before handling any metal part or equipment check shall be made to ensure that the same is dead.

### **Working on Bus Bars:**

- Line Clear-to-work shall be obtained for all work on H.T/E.H.T. Bus Bars.
- In isolating the point of work from supply, care shall be taken to disconnect right points in case of sectionalized ring and mesh schemes of Bus Bars.
- Isolators/Switches closing on the section Bus Bars on which work is to be carried out shall be locked in open position and the closing mechanism rendered inoperative.

### **Working on Instrument Transformers:**

- Line clear-to-work shall be obtained for all work on instrument transformers.

- The metal case of all instrument transformers shall be earthed. In handling instrument Transformers, the secondary of a current transformer shall not be opened while it is live.
- Before any work is carried out on an instrument or other device in a current transformer secondary circuit, the device shall be bridged (shorted) with jumpers, so that the circuit cannot be opened at the device. The circuit shall never be opened at meter connections until it has been bridged elsewhere.
- Potential transformer secondary shall never be short-circuited.
- Low voltage windings of potential transformers shall always have one side permanently and effectively earthed.
- The spare core terminals of secondary of CT shall not be kept open while working on these types of transformers or during replacement.

### **Working on Lightning Arresters:**

No work shall be done on a lightning arrester along with the earth wire unless it is disconnected from the live circuit and earthed at both the line and Earth terminals.

- Tanks of electrolyte or shields of oxide film lightening arresters must never be touched while arresters are energized.
- H.V. and E.H.V. lightening arresters where accessible, shall be provided with suitable fences against possible contact while the arresters are live. The gate of the fencing shall be kept locked and the keys under safe custody with the operator on duty.
- A Danger board shall be provided on the gate & on the fence.
- The flow of leakage current in the surge monitor shall be watched and recorded in every shift.

### **Working on Capacitors:**

- Line clear-to-work shall be obtained for all work on capacitors.
- For isolation of capacitors first open all cut outs or disconnecting device of the capacitors, then wait for at least 5 minutes for the internal resistor to reduce the voltage.
- Next short circuit and earth all terminals of the capacitors. The short circuited earthing jumper shall be left attached on the capacitors while work is being done.
- In short circuiting and earthing any capacitor or bank of capacitor no resistance or reactance shall be placed on any internal discharging circuit, but all individual capacitor terminals are to be connected to earth using the special leads where these are provided.

- Special precautions shall be taken when working on capacitors and their associated equipment when connected to transmission lines, e.g. coupling capacitors, capacitor potential devices, capacitors for power factor correction.
- In case of star connected bank of capacitors, neutral point shall be earthed before taking the work in hand.
- The H.V and E.H.V cables shall be treated as stored capacitor and after making cable circuit dead wait for at least 5 minutes before connecting to earth.
- The terminals of spare capacitor / capacitors that are kept idle shall be shorted with wire.

### **Safety precautions for working on Storage Batteries.**

- Only the authorized people who are familiarized with battery installation, charging and maintenance procedures should be permitted access to the battery area.
- Battery rooms should be well ventilated and should be provided with exhaust fans enough to ensure that pockets of trapped hydrogen gases do not occur particularly of the ceiling.
- Smoking, open flames or the use of tools or any other devices that are liable to cause sparks, should be avoided in storage Battery rooms, since in the operation of a battery, hydrogen gas is formed which may be explosive, if ignited.
- When mixing electrolyte, ***always add acid to water and not water to acid.*** Pour slowly and stir constantly to avoid excessive heat.
- While handling Sulphuric acid electrolyte, always use goggles and acid/alkali proof apron and gloves. Avoid spilling electrolyte. If electrolyte comes in contact with the skin, rinse with water immediately.
- To reduce the shock hazard due to short-circuit, insulate the handles of all tools used for tightening connector bolts. Also, remove the jewellery that could produce short-circuit.
- Un-insulated/unprotected tools, lamps are prohibited, Silk, Fur clothing creates static electricity, hence prohibited.
- Electric storage battery jars and cells, unless composed of glass, hard rubber or the insulating material, should be mounted on insulation supports.
- All battery connection shall be kept clean and tight so that sparking is avoided because of loose/corrode connections.
- The paint used on the Battery room walls should be fire retardant epoxy paint.
- While removing/replacing defective cells, the terminals of the adjacent batteries of the defective cell must not be shorted prior to opening to avoid short circuit.
- Battery voltage shall be measured by switching OFF the Battery charger.
- **A point of caution** - D.C. failure may occur during the intermediate period (if station supply fails). So to carry out the operation, adequate precaution is to be

taken either to divert the load to stand by set (if available) or may be done during the Grid shut down period.

### **Working on Cables:**

- Line clear-to-work shall be obtained before start of the work.
- For isolation of cables, open at least one set of disconnecting switches or remove fuses in every source through which the cable can be made alive including leads to the cable of potential transformers. Then discharge the cable to earth.
- Before digging out the point of cable fault, the authorised person shall determine the particulars of all cables in the vicinity of faulty cable.
- All cables in the vicinity of the fault point shall be exposed and identified to establish the identity of the faulty cable.
- Before a high or extra high voltage cable is cut, the Authorized Persons shall made definite checks to identify the cable and to ensure, that the cable has been made dead and earthed. He shall then spike the cable in an approved manner at the point where the cut is to be made.
- Before any high voltage joint or chamber is to be opened in circumstances where it is not desirable to spike the cable entering the joint or chamber, the Authorized Person shall satisfy from cable route record and if necessary by approved tests, that the joint or chamber is associated with the particular cable which has been made dead and on which it is safe to work.
- After completion of work, the cable shall be properly tagged and its position entered in appropriate drawing.
- Employees shall not step on live cables even though they are insulated and enclosed in a dead sheath. Tools and material shall not be rested over the sheath of the cable.

### **Isolator and Earth Switch Operation**

- The isolators should not be operated (open or close) on charged line / transformer.
- After opening the isolator, make sure that there is no pole stuck and all three poles of the isolators have been opened.
- After closing the isolator, make sure that all three poles of the isolators have been closed properly.
- The isolator should be locked with pad lock and key after opening and should be closed when Line clear is returned properly.
- When L/C is given for work on line, the Earthing switch is closed after opening the isolator and both should be locked in that position till return of L/C properly.
- In case of AB switches, it should be checked that all the three poles open or close simultaneously.

## **Painting and other work on Towers**

The following additional precautions shall be observed in case of towers carrying live conductors;

- No employee shall climb above the anti-climbing device unless under observation by another competent workman.
- No tools above **80 cms.** in length shall be taken up the tower;
- As far as practicable, the work shall be carried out from within the body of the tower.
- No employee shall work in a manner that his access way or arms or any tool extend beyond the clearance limitations fixed.

## **Working with Power Line Carrier Communication (PLCC) equipment**

- Adequate precautions shall be observed in connection with the work of carrier equipment;
- Carrier line shall not be worked on while the conductor is energized and unearthed.
- Coupling capacitor stacks shall not be worked on while the conductor is energized or unearthed. After the capacitor has been disconnected from the line conductor the top connection shall be discharged by temporary earth with an earth discharge rod.
- No contact shall be made with the carrier lead in conductor, except when using rubber gloves, or with lead in conductor, solidly earthed through the earthing switch in the event of safety gaps are breaking down the earth switch shall be closed before any contact is made with the carrier lead-in-conductor line tuning connections.
- Carrier lead-in-conductor shall not be disconnected from the line tuning unit unless the lead-in-conductor is definitely earthed at the coupling capacitor with the earthing switch which is provided. Operating rod shall be used for operation of the earth switch.
- When working on the transmitter or power amplifier unit, extreme care should be taken due to dangerous voltage which exists in each of these units. More than one workman, preferably one authorized officer should be present when working on this equipment.
- Fire extinguishers and First Aid apparatus / Kit shall be provided and maintained in all sub stations as detailed in Ch.14 & 15 respectively.

# **Safe working in in Operation & Maintenance of HT, LT Lines**

## **Cables and Equipments**

This unit deals with the safe working in O&M of HT, LT Lines Cables and equipments.viz, 33, 22, & 11 KV feeders emanating from Sub stations, Distribution Transformers , its associated equipments , LT feeders & Service lines.

Works in the above may be classified in to

- a) Planned work for maintenance / extension / improvement.
- b) Un precedent work like, breakdown / fault or failure rectification / replacement work that may arise due to natural calamities.

Before taking up any work, the following systematic approach shall be adhered to.

- The appropriate circuit to be switched OFF either by availing Line clear or BLINK.
- If availing blink it must be careful that, BLINK is for only Opening of the Switches and not for working.
- Proper communication shall be made between the receiver of Blink and the Operator at the Shift at Substation so as to understand the correct feeder, location, nature of work etc.
- After availing LC or Blink, the working personnel should ensure that the supply is switched OFF as per their requirement.
- It shall also be confirmed that there is no possibility of supply through any other source to this point viz, Generators, inverters, back feeding etc.
- After opening the appropriate switches by using PPEs, the switch shall be Locked and tagged out.
- Though now there may not be a provision for Locking at the AB switch handles at Field, necessary arrangements for fool proof locking shall be made within a time frame at Field for all the switches in the Distribution network by the Officers concerned.(DP, AB Switches of DT etc)
- It is a mandatory to provide Locks with double keys to each workman in the field those who are authorized to carry out Maintenance, fuse off call etc. One key to be with the

authorised workmen and another with the Section Officer / Supervisor.(Foreman / Line Inspector)

- The workmen shall compulsorily lock the Switches that have been opened by the Lock provided to him and the key shall be kept in safe custody with him.
- A Danger board in Post Office red Stating that “ MEN ON LINE , DO NOT OPERATE” shall be provided on the switch location.



- Climbing in the structure shall not be made through the Operating pipe.
- The HG / LT fuses shall be removed before starting the work.
- Even for renewal of fuses Earth rods shall be provided at appropriate locations.
- The equipment / Lines shall be discharged and then effectively earthed at necessary locations at work spot irrespective of Earthing provided at remote locations(at the Substation end or at the Switch Location)
- If the scheduled work is of long duration, and if necessary, depending on the site conditions the jumpers at the nearest location shall be removed. This is in addition to the Earthing and not substitutes for earthing.
- If the work is being carried out on one circuit of a double circuit, then it may be ensured that adequate clearances are available.
- Further minor works such as replacement of Pin insulator / Pin binding may be carried out in one circuit of double circuit.
- The above works shall be carryout in the supervision of a person not lower than the rank of a Line Inspector.
- Other works if any to be carried out in a circuit of Double circuit only if both the circuits are switched “OFF”
- If it is necessary to work on a HT line of HT / LT line with HT on Top and LT on bottom, then the LT Line shall be switched OFF.

- If the work is to be taken on LT line with HT in service, then
  1. An Earth screen must be available between HT & LT Lines OR
  2. There shall be no supply in the HT Line. OR
  3. If the section officer satisfies himself it is safe to work on LT line, the work may be carried out on his supervision.

### **Working on Live Lines**

An authorized person may work on any live line / equipment with voltage not exceeding 250 v under the following conditions

1. He shall use Safety waist belt rope.
2. He shall use rubber Gloves / Gauntlets
3. The other parts of the body except protected by Gloves / Gauntlets shall not be inserted / touch any of the live parts.
4. If the work is to be carried out during night times then it shall be with assistance and with the use of torch light.
5. Before starting of the work on line, it shall be ascertained from the ground the condition of the equipment overhead and also the nature & quantum of precautionary works.
6. Checking of his insulating materials with him also to be done.

### **Working in DT Structures**

- Before starting the work on structures it shall be ensured that the structure is safe for climbing and whether the bottom portion of the structure / poles are free from deterioration.
- All the PPEs required shall be made available.
- All the procedures and precautions and method of work execution and safe working places are kept in mind.
- All the tools shall be tied to a rope or tape so that it will not slip and fall down on others working / standing below the structure.



- If more than one person are to work on the same structure / pole, then the first person should climb and fix his position in a convenient working location. Then only the second person shall climb.
- Similarly while getting down; one person who climbed lastly shall get down. After reaching the ground only the other person shall get down.
- After climbing the structure / pole, waist belt rope shall be firmly tied to the cross arm or pole with proper knots and the knots shall be made in such a manner that the knots will not loosen by any action.
- The working person shall not make the knot with any insulator/ Conductors / Guys/ street light fittings. And they shall not rest themselves on any of these.
- Only minimum required tools may be carried along with him and if required other tools may be lifted through a bag attached to a hand line only.
- While dismantling of poles and its associated equipments, the new pole shall be tied with the old pole through stay wire and then the associated conductor and line materials may be shifted to the new pole. This may be done according to the site conditions.
- While dismantling conductors it shall be ensured that no conductor from strained location shall be dismantled first. While doing so it may also be ensured that the pole must have adequate strength to with stand the strain due to dismantling.
- If it happens that the conductors or materials are likely to fall on road side, then the road shall be blocked from traffic away for at least 10 feet.

## **TEMPORARY EARTHING**

- Temporary earths are those applied at the actual location of the work, during repair, maintenance or construction of installations, for the protection of workmen and installations.
- Earthing devices shall be of approved types, comprising properly designed clamps attached to insulated sticks of sufficient lengths to enable the clamps to be securely clamped to the conductors being earthed without an employee's hand approaching closer than the minimum safe working distances, each such line clamp is to be connected by a flexible copper earthing lead or of equivalent copper section of

aluminum cable to an adequate earth clamp or other device for attaching to permanent a connection or to a temporary earthing spike.

- The earthing should be connected to clean rust free nut bolts of equipment / installation / Earthing Electrode.
- When work is being carried out on a DT structure, then Earths shall be connected to the Earth electrode of the Structure and not any where else.
- Before doing any work on deadlines / installations or equipment where there is a possibility of their becoming energized from any source, such line / installation or equipment should be temporarily earthed between the location of work and all possible sources of energy.
- When Earthing lines / installations or equipment the connection to the Earth shall be made first and that to the circuit or equipment last. In removing Earth, first remove the connection to the circuit or apparatus and then remove the Earth connection.
- Approved discharge rods should be used in making Earth connection to the circuit / installation or apparatus.
- Where two or more crews are working independently on same line / installation or equipment, each crew shall properly protect him/her by placing their own temporary Earth at both sides of the work spot.
- When it is necessary to disrupt a line, bus bar or loop or to repair a damaged conductor or damaged loop, earths shall be placed on both sides of the work. When removing earthing leads, they shall be disconnected from the line conductor first and the earth system last.
- All works on dead circuit shall be done in between two sets of temporary earths done by the authorized person only.
- Temporary Earths shall never be attached or removed with bare hands. Rubber gloves shall always be used.
- The person making temporary earths on structures/equipment / line shall maintain his position below the level of conductor to be earthed in order to keep the body away from any arc that may occur when the earthing device is applied.
- No temporary earth shall be removed from the equipment while the work is in progress. Only authorized person has to remove the temporary earth.

- Employees shall not touch any conductor from which protective earths have been removed.
- Earthing of one conductor does not render other conductors safe for work. All phases shall be earthed even if work is to be carried out only on one phase.
- Temporary earth connections should not be connected to neutral wire, guy/stay wire or any other metal part of the structure except the place intended for it.
- The meaning of temporary earth is that it is done for the purpose of carrying out the specific work by creating a safety zone for the protection of working personnel from electric shock.
- The temporary earthing connection to the lines should be as close to the point of work as possible.

### **Removing the Temporary Earth connections**

- On completion of work, removal of the earthing and short-circuiting devices shall be carried out in the reverse order to that adopted for placing them, that is, the end of the earthing device attached to the conductors of the earthed mains / installations or apparatus shall be removed first and the other end connected to earth shall be removed last. The conductor shall not be touched after the earthing device has been removed from it.

### **Temporary Earthing: General precautions**

- The workman shall use rubber gloves and keep his body at least 60 cm. away from the earthing wire.
- In case where earthing is done through the station ground wire existing on the tower, it shall be examined to ensure that there is no cut or break on it.
- When steel tower or structure is used for earthing the lines, prior to connecting conductors there too, one leg of the tower/structure shall be earthed with approved earthing device.
- Earthing leads shall not be applied in any cell or compartment in which there is any exposed live conductor.
- For work on transformers, earths must be placed on each terminal or each winding.

- Before working on capacitors or underground cables, they shall be disconnected from the source of energy, discharged after delay of 5 minutes and then earthed. (to avoid residual Charge being discharged)
- Where a neon lamp, potential light voltmeter phasing sticks, or other device is employed for testing of live circuit, the device shall be tested before and after use to ascertain that the device is in working order.
- While working with overhead transmission lines, earths shall be placed on both sides of the tower on which work is being done as far as possible.
- While applying earths to overhead transmission lines place the earth wire on the lowest conductor first.
- When removing earthing leads, they shall be disconnected from the phases first and the earth system last.
- The receiving stations/Sub-station operator shall keep a record of the time of application and of removal of the temporary earths provided in the feeders / lines emanating from the sub-station in log book .

**Additional precautions to be taken on lines for protection against lightning:**

- During construction of H.T. line, after the conductor has been pulled in place and sagged, one or more earths shall be placed on the tower nearest to the point of temporary dead end or the point of snub and allowed to remain until conductor has been pulled in and sagged. New earths shall be put on or the old earth moved forwards as the sagging is completed. Always keep an earth connection between men working and the completely strung conductors.
- If during work on electric line, an electrical storm should approach so close that there appears a likelihood of a direct lightning stroke to the line, the employees concerned shall descend from the towers and shall keep clear of them until the danger has passed.

## **General safety precautions during work on any equipment or Line:**

- When any apparatus is not known to be adequately earthed, it shall be treated alive.
- Short circuiting of a circuit by a strap alone is not a safeguard until the short circuiting strap is properly earthed.
- Even though lines or other electrical equipment may have been isolated, they may be rendered dangerous due to induced voltage from neighboring circuits and therefore, they shall not be touched until the regular earthing procedure has been carried out.
- Never assume a circuit has been made dead, isolated and earthed on structures or towers with more than one circuit upon which work is being carried out, that any other circuit on the same structure or tower must necessarily be dead also.
- No earthing switch on high or extra high voltage apparatus shall be operated or temporary earth connections to such apparatus detached or removed except under the instruction of the authorized persons.
- While shifting the ladder in the switchyard special care shall be taken and the same should be shifted horizontally to avoid any contact with the live part.
- As far as possible all poles shall be provided with step cross arms at appropriate height for working conveniently
- Earth discharge rods should be of adequate current and voltage withstanding capacity as per the requirement of the system and it should be of an approved one.
- The point of connection of earth discharge rod should be tightly fixed with the solid earthing ground and it shall not be a loose one.

## **Special important works on the aspect of safety**

- Before taking up the maintenance work on Distribution Transformer Structure, it shall be ensured that the yard is kept neat and tidy as to whether there is any weed growth / water logging to avoid accidental earthing of the body of the operating personnel.
- The Distribution Transformer yard shall be spread with stone crusher jelly with a layer of 10 mm thick to minimise the appearance of Step and touch potentials which is safe to the operating personnel.
- The DT structure shall be fenced and locked to restrict access to un authorized persons and dumping of garbage waste.

- In any case the neutral of one Distribution transformer shall not be extended to any other network(This may occur in case of street lights)
- Generally in LT network Two feeder junction shall be avoided. If it is un avoidable then, the pole on which the two feeders are terminated shall be painted in “POST OFFICE RED” in addition to providing a Board of caution “DANGER-TWO FEEDER JUNCTION” with Skull & Bone. For additional safety a dummy span may also be provided.



- In no case and in no location Bolts & nuts are used for the support of LT neutral conductor. Only Aluminium / GI knobs shall be used for the support of Neutral conductor to avoid snapping of neutral.
- Only strap sets shall be used at shackle points.
- Utmost care shall be taken while topping up of oil in the Distribution Transformer as to whether the container of Oil is free from combustibile particles.(like petrol, Diesel, kerosene etc)
- While a person is working on the Distribution Transformer structure, no person shall stand under the proximity of falling objects so that no tools or equipments shall fall on the person causing injury.
- While working on Structures / Lines appropriate PPEs shall be properly used.
- As far as possible the person shall not have sharp objects in his pockets while working.
- Using of Mobile phone while working is strictly prohibited.
- Before the operation of the Ring main units (RMUs) it must be ensured that the SF6 Gas pressure inside the chamber is adequate. This can be ensured by seeing the pressure gauge of the RMU.
- In no case the pillar box shall be in open condition and also it shall be ensured that the pillar boxes are erected with sufficient height above the flood level reached so far.

## EFFECTIVE EARTHING PRACTICES TO ENSURE SAFETY

- Prime Objective of earthing is to provide a Zero potential surface in and around and under the area where the electrical equipment is installed or erected.
- To achieve this objective the non-current carrying parts of the electrical equipment is connected to the general mass of the earth which prevents the appearance of dangerous voltage on the enclosures and helps to provide safety to working Personnel and public.
- Further the following arising dangerous potentials shall be kept within limits and within safe values. This could be achieved only by a good earthing system.

### TOUCH POTENTIAL:

If a man touches the metal part of equipment during fault, the maximum potential difference that will exist between hand and foot is called TOUCH POTENTIAL.

### STEP POTENTIAL:

The maximum potential difference between legs of a man when standing on the ground the pace being 1 meter is called STEP POTENTIAL.

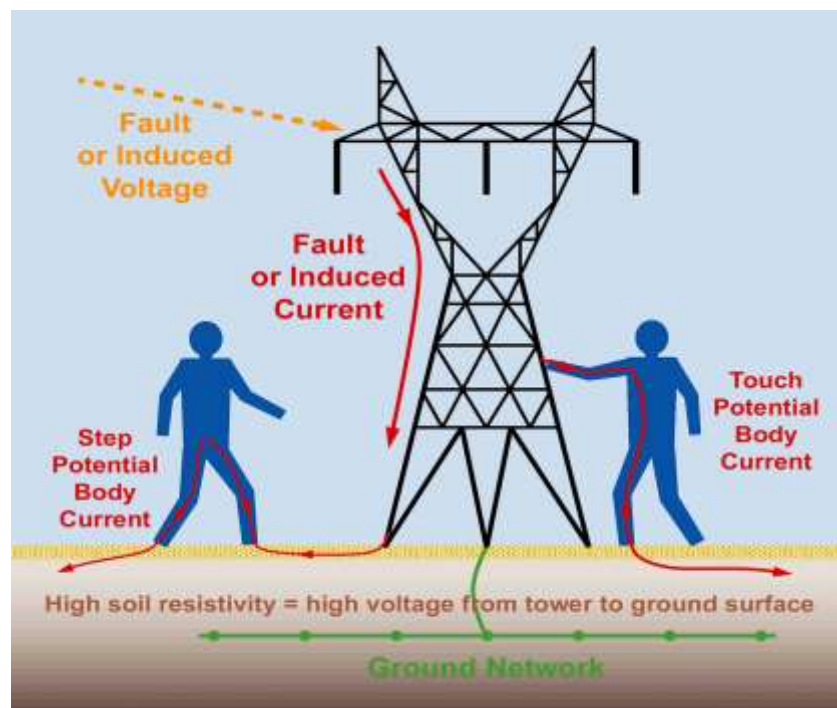

## **TRANSFER POTENTIAL:**

This is the maximum potential difference between the equipment other than electrical equipment, like water line, fencing etc. to the ground not connected directly to the equipment or earthing system.

To keep / reduce the above potentials a layer of 10 mm thick gravel / crushed stone will be spread around the equipment which reduces the touch and step potentials to a low value by virtue of its high resistivity and non-continuous path.

## **Purpose of Earthing**

1. Reducing insulation level of electrical equipment
2. Ensuring safe operation of Power System
3. Ensuring personnel safety
4. Eliminating electrostatic Accidents
5. Detecting Ground faults
6. Equiv. potential Bonding
7. Reducing Electromagnetic Interference
8. Reducing Step Potential, Touch Potential and Transfer Potential

- **All earthing systems shall, -**

- a. consist of equiv. potential bonding conductors capable of carrying the prospective earth fault current and a group of pipes, rods and plate electrodes for dissipating the current to the general mass of earth without exceeding the allowable temperature limits as per relevant Indian Standards in order to maintain all non-current carrying metal works reasonably at earth potential and to avoid dangerous contact potentials being developed on such metal works;
- b. limit earth resistance sufficiently low to permit adequate fault current for the operation of protective devices in time and to reduce neutral shifting;
- c. be mechanically strong, withstand corrosion and retain electrical continuity during the life of the installation and all earthing systems shall be tested to ensure efficient earthing, before the electric supply lines or apparatus are energised.



- All earthing systems belonging to the supplier shall in addition, be tested for resistance on dry day during the dry season not less than once every two years.(However we shall test for the same once in a year
- A record of every earth test made and the result thereof shall be kept by the supplier for a period of not less than two years after the day of testing and shall be available to the Electrical Inspector when required.
- The following conditions shall apply to the connection with earth of systems at voltage normally exceeding 125 V but not exceeding 650V namely: -
  1. neutral conductor of a 3-phase, 4-wire system shall be earthed by not less than two separate and distinct connections with a minimum of two different earth electrodes or such large number as may be necessary to bring the earth resistance to a satisfactory value both at the generating station and at the sub-station.
  2. the earth electrodes so provided, shall be inter- connected to reduce earth resistance.
  3. neutral conductor shall also be earthed at one or more points along the distribution system or service line .
- In the case of a system comprising electric supply lines having concentric cables, the external conductor of such cables, shall be earthed by two separate and distinct connections with earth.
- The connection with earth may include a link by means of which the connection may be temporarily interrupted for the purpose of testing or for locating fault.
- no person shall make connection with earth by the aid of, nor shall he keep it in contact with, any water mains not belonging to him except with the consent of the owner thereof and of the Electrical Inspector.

- Alternating current systems which are connected with earth as aforesaid shall be electrically interconnected: Provided that each connection with earth is bonded to the metal sheathing and metallic armoring, if any, of the electric supply lines concerned.
- The frame of every generator, stationary motor, portable motor, and the metallic parts, not intended as conductors, of all transformers and any other apparatus used for regulating or controlling electricity, and all electricity consuming apparatus, of voltage exceeding 250 V but not exceeding 650 V shall be earthed by the owner by two separate and distinct connections with earth.
- Neutral point of every generator and transformer shall be earthed by connecting it to the earthing system by not less than two separate and distinct connections.
- All metal casing or metallic coverings containing or protecting any electric supply line or apparatus shall be connected with earth and shall be so joined and connected across all junction boxes and other openings as to make good mechanical and electrical connection throughout their whole length:
- All Earth connections shall be visible for inspection
- Each Earth System shall be so devised that the testing of individual Earth Electrode is possible.
- The following are to be earthed effectively
  1. All metal parts including body of the equipments.
  2. Lightning arresters
  3. Neutral( Multiple Earthing)
  4. AB Switch handle
- In special locations, Railway and Telegraph line crossing, Special Structures etc., Pipe / Rod Earthing should be done.
- At all other locations coil Earthing may be adopted.

### **Earthing of Poles:**

- All metallic supports shall be permanently and effectively earthed.
- Metal cross arms and insulators points on poles shall be bonded together and normally earthed at every pole for 33KV / 22KV / 11KV Lines and at every fifth pole for lines below 500V.
- The support on each side of road crossing, Railway crossing or River crossing shall be earthed.

- All steel poles on which switches, transformers , fuses etc., are mounted shall be earthed.
- All poles above 650V irrespective of inhabited areas shall be earthed. For poles below 650V, Guarding with continuous earth wire shall be provided invariably connected to earth at 3 equiv. distant points in 1 KM.
- Whenever the electric lines pass close to a well or a permanently moist place, an earth should be provided in the well or the marshy place and connected to the electric line pole.

### **Earthing of Distribution Transformers:**

Pipe Earthing or Rod earthing shall preferably be provided for the distribution Sub-Stations as below.

- For earthing three earth pits in triangular formation at a distance of six meter from each other are to be provided.
- Earth pit should be digged for 45 cm x 45 cm size and 5 ft. depth.
- 3 Nos. of 40 mm dia and 2.9 mm thickness and 3 mts. (10 ft) length of earth pipe should be used for earthing.
- For better earth connection, one G I clamp should be welded to the earth pipe.
- One direct connection through G.I wire, from the high voltage surge arresters and another direct and separate connections from the low voltage surge arresters ( if low voltage surge arresters are provided.) to the earth pit No. 1 as shown in the figure below.
- Two separate distinct connections through G I wire should be made from the transformer neutral bushing to the earth pit No. 2.
- Two separate distinct connections through GI wire from the following parts of the structure should be made to the earth pit No. 3 as shown in figure below.
  - ❖ Metal part of the disc and stay.
  - ❖ Top channel.
  - ❖ AB switch frame, metal part of the insulator, side Arms.
  - ❖ HG fuses frame and metal part of the insulator.
  - ❖ LT cross arm, metal part of the insulator, open type fuse frame.
  - ❖ AB switch guide and operating pipe ( At the top and bottom )
  - ❖ Transformer body.
  - ❖ Belting angle.
  - ❖ Seating channel
- The inter connection of Earth Electrodes shall be made except the one to which LAS earth is connected.

- Neither the earth connections nor interconnections shall have joints in the conductors.
- The connections shall be of firm and there should be no loose connections.
- No MS material shall be allowed in joints (bolts, nuts and washers) to avoid earth resistance becoming high.
- The earth connections from the lightning arresters shall be connected to the earth electrode which is having low individual earth resistance as per norms.
- If required to improve the Earth resistance, additional earth Pit may be provided as 4<sup>th</sup> one.

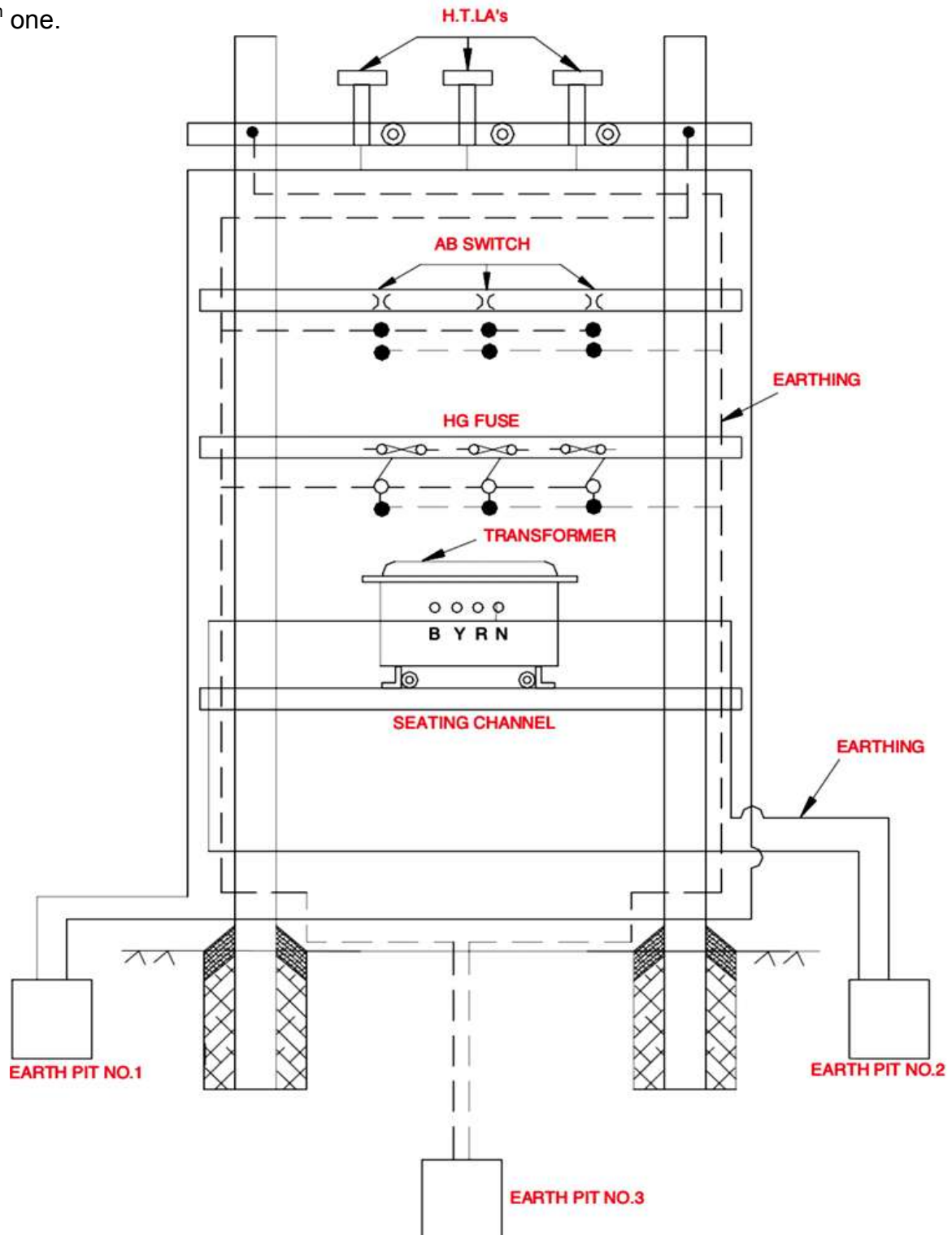

### **Recommended Combined Values for Earth Resistance.**

a.	for Major Sub Station	1 Ohm
b.	for Minor Sub Station	2 Ohm
c.	Power House	0.5 Ohm
d.	Distribution Transformer	5 Ohm

### **REQUIREMENT OF GOOD EARTHING**

- Good earth should have low resistance
- It should stabilize circuit potential with respect to ground and limit overall potential rise.
- It should protect men material from injury or damage due to over voltage.
- It should provide low impedance path to fault currents to ensure prompt and consistent operation of protective relays, Surge arrester etc.,
- It should keep maximum potential gradient along the surface of the sub-station within safe limits during ground fault.

### **Procedure for Providing Temporary Earthing**

#### **1) DT Structure**

- The earth rods used shall confirm to the specifications as mentioned in Chapter.6 of this manual.
- The AB switch shall be opened by using Hand Gloves and confirmed that the AB switch blades are fully opened.
- Before providing earthing, the ends of the earth rods shall be tightened firmly to the Earth pipe.
- Then the person who is making earthing shall climb through the pole and rest safely with wooden stick tied with rope and use waist belt rope and stand at a safe distance.

- He shall collect the earth rod from the ground and bring one of the earth rod to close proximity of the conductor after AB switch (arcing distance) and ensure that no arcing takes place.
- After providing Earthing the works may be carried out safely as specified.
- After completion of works, the Earth rods may be removed first with Gloves on hand and then connections removed at Earth pipe.

## 2) On HT / LT Lines:

- Before starting the work necessary Line clear shall be obtained and it shall confirmed that there is no supply.
- Before providing earthing, the ends of the earth rods shall be tightened firmly to the pole earth
- If pole earth is not available, a metal spike may be driven to a depth of at least 3 feet and watering may also be done to get effective earthing. Then the leads of the earth wire shall be connected firmly to this spike
- Then the person shall climb the pole , stay in a comfortable position in the wooden stick tied with rope below the cross arm and with waist belt, approach the other end of one earth rod to all the phases within the arcing distance and if no arcing is found, then the earth rods shall be put to the line in all the three phases.
- After providing Earthing the works may be carried out safely as specified.
- After completion of works, the Earth rods may be removed first with Gloves on hand and then connections removed from the Earth.

## 3) PILLAR BOX

- To attend a fault in a pillar box or in a cable emanating from the pillar box, the incoming LT supply to the pillar box must be disconnected by removing the fuses in the feeder cable using proper hand gloves.
- Before taking up the work in a cable emanating from a pillar box, it must be ensured the cable is temporarily earthed.
- For temporary earthing, a set of three crocodile clips of sufficient current carrying capacity connected with wires of adequate capacity shall be used.



- Any one phase shall be connected to earth of the pillar box using the first set of crocodile clip and then the three bus bars are interconnected with the remaining 2 sets of crocodile clips.
- After completion of the work the crocodile clips on the bus bar shall be removed first and earthing shall be removed last and then the supply restored.
- During the entire process hand gloves shall be used.

## Safety in Consumer's Premises

Safety for Consumers is of Prime importance, since they are the end users. Therefore care has to be exercised in effecting Service Connections and no safety regulation is compromised. The following which are in line with CEA regulations are to be adopted scrupulously.

- It shall be ensured that the Horizontal, vertical and other required clearances as stipulated in Chapter (13) are adequately met. If the clearances are inadequate, the consumer may be advised as per Annexure – 2, to get the lines deviated by proper application and on payment of appropriate charges wherever feasible.
- Each switch board shall have a clear space of not less than 1 metre in width in front of the Switch board.
- Where bare conductors are used in a building the owner of such conductor shall a) ensure that they are in accessible, b) Provide in readily accessible position, switches for rendering them dead whenever necessary and c) take such other safety measures as necessary.
- No flammable / dust / waste shall be dumped under the meter / switch board. It shall be easily accessible in case of emergency.
- Each Service connection shall be provided with aerial cut-out fuse in the tapping point of the pole / box, such that in case of any overload / faults the supply to the premises will be cut off.
- Supply shall not be effected to a Premises unless it is reasonably satisfied that the installation will not at the time of making the Connection cause a leakage from that installation or apparatus of a magnitude detrimental to safety which shall be checked by measuring the insulation resistance values
- All equipments shall have the IR Value as stipulated in the relevant IS.

Voltage level	Minimum IR value required (not less than)
Not exceeding 650 Volts (For single phase & Three Phase)	1(One) Mega Ohm *
exceeding 650 Volts but not exceeding 33000 Volts (For HT)	5 (Five) Mega Ohm **



\* The insulation resistance measured on application of 500V Dc between each live conductor and Earth for a period of 1 minute.(Under de-energised condition)

\*\* The insulation resistance measured on application of 2.5 KV DC between each live conductor and earth for a period of 1 minute.(Under de-energised condition)

- Appropriate insulation testers(Megger) shall be made available in all the Offices from where Service connections are effected.
- The Value of the IR value shall be recorded in the test report and by which the measurement is made (Make, SI.No.of the instrument) shall also be recorded in the Test report.
- The General terms such as “Satisfactory” or “OK” shall be avoided and values shall be recorded.
- At an interval of not exceeding 5 years every service shall be tested and the defects noticed shall be communicated to the consumer in writing.
- Upon inspection if the IR value is found so low, as to prevent safe use of electricity, the service may be disconnected after issue of 48 hrs notice to the consumer of disconnecting supply and shall not re commence supply until it is satisfied that the cause of leakage has been removed.
- The Consumer shall be provided with an earthed terminal on his premises, for his use in an accessible position near the point of supply. (Explanation: Since our neutral is effectively earthed at Transformer location, the neutral can be considered as Earthed terminal.
- For the installations of voltage exceeding 250V, the consumer shall in addition to the aforementioned earthing arrangement, provide his own earthing system with an independent electrode.(Explanation: For Three phase services, an additional Earth shall be made by the Consumer by an independent Earth electrode. The Earth Electrode resistance shall be recorded on the Test report separately.
- It shall be ensured that at no point, the neutral of the supplier shall be earthed by the consumer, but the consumer can earth their own equipments for protection.
- Any work within the Consumers premises including additions, alterations, repairs and adjustments to the existing except such replacement of Lamps, fans, switches, domestic appliances of Voltage not exceeding 250 V shall be

carried out by an Electrical Contractor licensed in this behalf by the state Govt. and by a person holding a permit issued or recognized by the Govt.

- New services / additional services / reconnection of services after a period of 6 months shall be tested and a RTR shall be obtained. Testing of Services and IR values shall be as above.

### **Protection against Earth Leakage**

- Regulation 42 mandates the provision of Earth leakage protective device as follows.
- “The supply of Electricity to every installation other than voltage not exceeding 250V, below 2 KW and those installations of voltage not exceeding 250V, which do not attract the provisions of Section 54(Supply to X-ray installations), of the act shall be controlled by an earth leakage protective device whose maximum earth leakage threshold for tripping should not exceed 30 mA for domestic connection and 100mA for all other installations so as to disconnect the supply instantly on the occurrence of earth fault or leakage current”.
- Explanation:- For single phase Service connection, the consumer shall be insisted to provide mandatorily a Earth leakage protective device of rating not exceeding 30mA(trip) for Earth fault or leakage protection.  
For Other installations the Earth leakage protective device is of the rating not exceeding 100mA (trip)  
Further for 3 Phase service connections also the above regulation is applicable but with a connected load of below 2 KW. The details shall be recorded in the Test report and it shall be the responsibility of the person who is effecting service connection.
- If solar net metering is installed at consumer’s premises, a separate earth pit to be maintained to prevent accident other than the above said earthing arrangement. The same shall be applicable to Generator set also and 4 pole isolation arrangement (TPN) must be provided.

### **Safety precautions in domestic installations**

- The wiring shall be done with Copper wires / cables of adequate size and good insulation resistance.

- Do not touch an electric switch / appliance when hands are wet.
- Be alert while replacing fuses / inserting plugs
- Proper fuse wires only shall be used
- Do not replace fuse unless cause for blowing out is detected
- Do not hang wet clothes on electrical fittings / conductors
- Use 3 pin plugs and ensure that earth connection is proper

## STANDARD DISTANCES AND CLEARANCES

- This chapter deals with the standard clearances and spacing to be adopted in various electrical installations
- The relevant regulations of CEA on Safety Measures are reproduced here for strict adherence.
- Any amendments in the regulations will hold good for this chapter also.

### Regulation 58. Clearance above ground of the lowest conductor of overhead lines.-

No conductor of an overhead line, including service lines, erected cross a street shall at any part thereof be at a height of less than-

SI No.	Level of voltage	Distance in Meters
i)	for lines of voltage not exceeding 650 Volts	5.8
ii)	for lines of voltage exceeding 650Volts but not exceeding 33kV	6.1

No conductor of an overhead line,including service lines, erected along any street shall at any part thereof be at a height less than-

SI No.	Level of voltage	Distance in Meters
i)	for lines of voltage not exceeding 650 Volts	5.5
ii)	for lines of voltage exceeding 650 Volts but not exceeding 33kV	5.8

No conductor of an overhead line including service lines, erected elsewhere than along or across any street shall be at height less than–

SI No.	Level of voltage	Distance in Meters
i)	for lines of voltage up to and including 11000 volts, if bare	4.6
ii)	for lines of voltage up to and including 11000 volts, if insulated	4.0
iii)	for lines of voltage exceeding11000 volts, but not exceeding 33000 volts	5.2

1. For lines of voltage exceeding 33 kV the clearance above ground shall not be less than 5.2 meters plus 0.3 meter for every 33,000 Volts or part there of by which the voltage of the line exceeds 33,000 Volts; Provided that the minimum clearance along or across any street shall not be less than 6.1metres.
2. For High Voltage Direct Current (HVDC) lines, the clearance above ground shall not be less than:-

Sl.No.	DC Voltage(kV)	Ground Clearance(mtrs.)
1	100kV	6.1
2	200kV	7.3
3	300kV	8.5
4	400kV	9.4
5	500kV	10.6
6	600kV	11.8
7	800kV	13.9

3. Ground clearances shall be as specified in schedule below.

**Regulation 60: Clearance from buildings of lines of voltage and service lines not exceeding 650 Volts.-**

1) An overhead line shall not cross over an existing building as far as possible and no building shall be constructed under an existing overhead line.

2) Where an overhead line of voltage not exceeding 650 V passes above or adjacent to or terminates on any building, the following minimum clearances from any accessible point, on the basis of maximum sag, shall be observed, namely:-

i) for any flat roof, open balcony, verandah roof and lean-to-roof-

1. when the line passes above the building a vertical clearance of 2.5 metres from the highest point,and
2. when the line passes adjacent to the building a horizontal clearance of 1.2 metres from the nearest point, and

ii) for pitched roof-

- a. when the line passes above the -building a vertical clearance of 2.5 metres immediately under the line, and
- b. when the line passes adjacent to the building a horizontal clearance of 1.2metres.

- 3) Any conductor so situated as to have a clearance less than that specified above shall be adequately insulated and shall be attached at suitable intervals to a bare earthed bearer wire having a breaking strength of not less than 350kg.
- 4) The horizontal clearance shall be measured when the line is at a maximum deflection from the vertical due to wind pressure.
- 5) Vertical and horizontal clearances shall be as specified in schedule-X.

Explanation: - For the purpose of this regulation, the expression"building" shall be deemed to include any structure, whether permanent or temporary.

**Regulation 61: Clearances from buildings of lines of voltage exceeding 650V.-**

1) An overhead line shall not cross over an existing building as far as possible and no building shall be constructed under an existing overhead line.

2) Where an overhead line of voltage, exceeding 650 V passes above or adjacent to any building or part of a building it shall have on the basis of maximum sag a vertical clearance above the highest part of the building immediately under such line, of not less than-

SI No.	Level of voltage	Distance in Meters
i)	for lines of voltages exceeding 650 Volts up to and including 33,000 Volts	3.7
ii)	for lines of voltages exceeding 33 kV	3.7 meters Plus 0.30 meters for every additional 33KV or part thereof

3) The horizontal clearance between the nearest conductor and any part of such building shall, on the basis of maximum deflection due to wind pressure, be not less than-

SI No.	Level of voltage	Distance in Meters
i)	for lines of voltages exceeding 650 Volts up to and including 11,000 Volts	1.2
ii)	for lines of voltages exceeding 11000 Volts and up to and including 33,000 Volts	2.0
iii)	for lines of voltages exceeding 33 KV	2.0 meters Plus 0.30 meters for every additional 33KV or part thereof

4) For High Voltage Direct Current (HVDC) systems, vertical clearance and horizontal clearance, on the basis of maximum deflection due to wind pressure, from buildings shall be maintained as below:

SI.No	DC Voltage(kV)	Vertical Clearance (mtrs.)	Horizontal Clearance (mtrs.)
1.	100kV	4.6	2.9
2.	200kV	5.8	4.1
3.	300kV	7.0	5.3
4.	400kV	7.9	6.2
5.	500kV	9.1	7.4
6.	600kV	10.3	8.6
7.	800 KV	12.4	10.7

5). Vertical and horizontal clearances shall be as specified in schedule below

Explanation: - For the purpose of this regulation the expression "building" shall be deemed to include any structure, whether permanent or temporary.

- Whenever applications are received from consumers requesting Service connections to their premises irrespective of Tariff, it shall be ensured that the above Horizontal / vertical clearances are met out.
- If such cases arise on inadequate clearances, the applicant may be issued with a

notice to get the adequate clearance by making arrangements for deviation of existing lines / poles / installations from the supplier on payment of the estimated cost

- Even after issue of notice to the applicant to pay the amount for deviation of the above, and the applicant does not come forward for deviation of the above, the applicant may be issued with a notice asking him to indemnify the supplier from any losses thereto due to the prevailing unsafe condition and make them clear that the supplier will not be held responsible for any untoward incident happens. OR The supply may be refused until the adequacy of clearance is met out

#### **Regulation 62 : Conductors at different voltages on same supports.-**

Where conductors forming parts of systems at different voltages are erected on the same supports, the owner shall make adequate provision to guard against danger to linemen and others, from the lower voltage system being charged above its normal working voltage, by leakage from or contact with the higher voltage system and the methods of construction and the applicable minimum clearances between the conductors of the two systems shall be as specified in regulation 69 for lines crossing each other.

#### **Regulation 63 : Erection or alteration of buildings, structures, flood banks and elevation of roads.-**

- 1) If at any time subsequent to the erection of an overhead line, whether covered with insulating material or not, any person proposes to erect a new building or Structure or flood bank or to raise any road level or to carry out any other type of work whether permanent or temporary or to make in or upon any building, or structure or flood bank or road, any, permanent or temporary addition or alteration, he and the contractor whom he employs to carry out the erection, addition or alteration, shall give intimation in writing of his intention to do so, to the supplier or owner and to the Electrical Inspector and shall furnish therewith a scale drawing showing the proposed building, structure, flood bank, road or any addition or alteration and scaffolding thereof required during the construction.
- 2) On receipt of such intimation, the supplier or owner shall examine,-
  - a) Whether the line or Underground Cable under reference was laid in accordance with the provisions of these regulations and any other law for the time being in force
  - b) whether it is technically feasible;
  - c) whether it meets the requirement of Right of Way (ROW);
  - d) whether such person was liable to pay the cost of alternation of the



overhead line and if so, send a notice without undue delay, to such person togetherwith an estimate of the cost of the expenditure likely to be incurred to so alter the overhead line and require him to deposit, within thirty days of the receiptof the" notice, with the supplier or owner, the amount of the estimated cost.

- 3) If such person disputes the cost of alteration of the overheadlineestimated by the supplier or owner or even the responsibility to pay such cost, the dispute may be referred to the Electrical Inspector who shall after hearing both parties decide upon the issue in accordance with sub regulation (4).
- 4) The Electrical Inspector shall estimate the cost of alteration of overhead line on the following basis, namely:-
  - i. the cost of material used on the alteration after crediting the depreciated" cost of the material which shall be available from the existingline or UG Cable.
  - ii. the wages of labour employed in affecting the alteration;
  - iii. supervision charges and charges incurred by the supplier or owner in complying with the provisions of section 67 of the Act, in respect of such alterations.
- 5) Any addition or alteration to the building or structure shall be allowed only after the deposit of such estimated cost to the supplier or owner.
- 6) No work upon such building, structure, flood bank, road and addition or alteration thereto shall be commenced or continued until the Electrical Inspector has certified that the provisions of regulation 58, 60 and 61 should not be contravened either during or after the aforesaid construction: Provided, that the Electrical Inspector may, if he is satisfied that the overhead line or UG Cable has been so guarded as to secure the protection of persons or property from injury, certify that the work may be executed prior to the alteration of the overhead line or UG cable or in the case of temporary addition or alteration, without alteration of the overhead line or OG Cable.
- 7) The supplier or owner shall, on receipt of such deposit, alter the overhead line or UG Cable in such a way that it does not contravene the provisions regulation 58, 60,61& 76 either during or after such construction within two months from the date ofsuch deposit or within such longer period as the Electrical Inspector maypermit for reasons to be recorded in writing.

#### **Regulation 64 : Transporting and storing of material near overhead lines.-**

- 1) No rods, pipes or similar materials shall be taken below, or in the vicinity of, any bare overhead conductors or lines if these contravene the provisions of regulations 60 and 61 unless such materials are transported under the direct supervision of a person designated in this behalf by the owner of such overhead conductors or lines.
- 2) No rods, pipes or other similar materials shall be brought within the flash over distance of bare live conductors or lines.
- 3) No material or earth work or Agricultural produce shall be dumped or stored, no trees grown below or in the vicinity of, bare overhead conductors, or lines to contravene the provision of regulations 60 and 61.
- 4) No flammable material shall be stored under the electric supply line.
- 5) No fire shall be allowed above underground cables.
- 6) Firing of any material below electric lines shall be prohibited.

#### **Regulation 65. General clearances.-**

- 1) For the purpose of computing the vertical clearance of an overhead line, the maximum sag of any conductor shall be calculated on the basis of the maximum sag in still air and the maximum temperature as specified under regulations 57 and computing any horizontal clearance of an overhead line the maximum deflection of any conductor shall be calculated on the basis of the wind pressure specified under regulations 57.
- 2) No blasting for any purpose shall be done within 300 metres from the boundary of a sub-station or from the electric supply lines of voltage exceeding 650 V or tower structure thereof without the written permission of the owner of such sub-station or electric supply lines or tower structures and in case of mining lease hold area, without the written permission of the Inspector of Mines.
- 3) No cutting of soil within ten meters from the tower structure of 132 kV and above voltage level shall be permitted without the written permission of the owner of tower structure.
- 4) No person shall construct brick kiln or other polluting units near the installations or transmission lines of 220 kV and above within a distance of 500 metres.

#### **Regulation 66 : Routes proximity to aerodromes.-**

Overhead lines shall not be erected in the vicinity of aerodromes unless the Airport Authorities have approved in writing the route of the proposed lines as-per relevant Indian Standards.

### **Regulation 67 : Maximum interval between supports .-**

All conductors shall be attached to supports at intervals not exceeding the safe limits based on the ultimate tensile strength of the conductor and the factor of safety specified under regulations 57

Provided that in the case of overhead lines carrying conductors of voltage not exceeding 650 V when erected in, over, along or across any street, the interval shall not, without the consent in writing of the Electrical Inspector, exceed 65 metres.

### **Regulation 68. Conditions to apply where telecommunication lines and power lines are carried on same supports.**

- (1) Every overhead telecommunication line erected on supports carrying a power line shall consist of conductors each having a breaking strength of not less than 270kg.
- (2) Every telephone used on a telecommunication line erected on supports carrying a power line shall be suitably guarded against lightning and shall be protected by cut-outs.
- (3) Where a telecommunication line is erected on supports carrying a power line of voltage exceeding 650 V, arrangement shall be made to safeguard any person against injury resulting from contact, leakage or induction between such power and telecommunication lines.

### **Regulation 69 : Lines crossing or approaching each other and lines crossing street and road.-**

Where an overhead line crosses or is in proximity to any telecommunication line, the owner of either the overhead line or the telecommunication line, whoever lays his line later, shall arrange to provide for protective devices or guarding arrangement and shall observe the following provisions, namely:-

- (i) when it is intended to erect a telecommunication line or an overhead line which will cross or be in proximity to an overhead line or a telecommunication line, as the case may be, the person proposing to erect such line shall give one month's notice of his' intention so to do along with the relevant details of protection and drawings to the owner of the existing line;
- (ii) guarding shall be provided where lines of voltage not exceeding 33 kV cross a road or street;
- (iii) where an overhead line crosses or is in proximity to another overhead line, guarding arrangements shall be provided so to guard against the

possibility of their coming into contact with each other;

- (iv) where an overhead line crosses another overhead line, clearances shall be as under:-

(Minimum clearances in metres between lines crossing each other)

Sl. No	Nominal System Voltage	11- 66 kV	110-132 kV	220kV	400kV	800kV
1.	Low and Medium	2.44	3.05	4.58	5.49	7.94
2.	11-66kV	2.44	3.05	4.58	5.49	7.94
3.	110-132kV	3.05	3.05	4.58	5.49	7.94
4.	220kV	4.58	4.58	4.58	5.49	7.94
5.	400kV	5.49	5.49	5.49	5.49	7.94
6:	800kV	7.94	7.94	7.94	7.94	7.94

Provided that no guarding are required when line of voltage exceeding 33 kV crosses over another line of 250 V and above voltage or a road or a tram subject to the condition that adequate clearances are provided between the lowest conductor of the line of voltage exceeding 33 kV and the top most conductor of the overhead line crossing underneath the line of voltage exceeding 33 kV and the clearances as stipulated in regulation 58 from the top most surface of the road maintained;

- (v) where an overhead direct current (DC) line crosses another overheadline, clearances shall be as under:-

(Minimum clearances in metres between AC and DC lines crossing each other)

Sl. No.	System Voltage AC/DC	100 kV DC	200 kV DC	300 kV DC	400 kV DC	500 kV DC	600 kV DC
1.	Low and medium AC	3.05	4.71	5.32	6.04	6.79	7.54
2.	11-66 AC	3.05	4.71	5.32	6.04	6.79	7.54
3.	110-132 kV AC	3.05	4.71	5.32	6.04	6.79	7.54
4.	220 kV AC	4.58	4.71	5.32	6.04	6.79	7.54

Sl. No.	System Voltage AC/DC	100 kV DC	200 kV DC	300 kV DC	400 kV DC	500 kV DC	600 kV DC
5.	200 kVDC	4.71	4.71	5.32	6.04	6.79	7.54
6.	300 kVAC	5.32	5.32	5.32	6.04	6.79	7.54
7.	400 kVAC	5.49	5.49	5.49	6.04	6.79	7.54
8.	400 kVDC	6.04	6.04	6.04	6.04	6.79	7.54
9.	500 kVDC	6.79	6.79	6.79	6.79	6.79	7.54
10.	600 kVDC	7.54	7.54	7.54	7.54	7.54	7.54
11.	800 kVDC	7.94	7.94	7.94	7.94	7.94	7.94

- (vi) a person erecting or proposing to erect a line which may cross or be in proximity with an existing line, shall provide arrangements on his own line or require the owner of the other overhead line to provide guarding arrangements as referred to in clause (iii) and (iv);
- (vii) in all cases referred to in this regulation the expenses of providing the guarding arrangements or protective devices shall be borne by the person whose line was last erected;
- (viii) where two lines cross, the crossing shall be made as nearly at right angles as the nature of the case admits and as near the support of the line as practicable, and the support of the lower line shall not be erected below the upper line;
- (ix) the guarding arrangements shall ordinarily be carried out by the owner of the supports on which it is made and he shall be responsible for its efficient maintenance.

**Regulation 70. Guarding. –**

- 1) Where guarding is required under these regulations the following shall be observed, namely:-
  - (i) every guard-wire shall be connected with earth at each point at which its electrical continuity is broken;
  - (ii) every guard-wire shall have an actual breaking strength of not less than 635 kg and if made of iron or steel, shall be galvanised;
  - (iii) every guard-wire or cross-connected systems of guard-wires shall have sufficient current-carrying capacity to ensure them rendering dead, without risk of fusing of the guard-wire or wires, till the contact of any live wire has been removed.

### **Regulation 71. Service lines from overhead lines.–**

No service-line of tapping shall be taken off an overhead line except at a point of support: Provided that the number of tapping per conductor shall not be more than four in case of connections at voltage not exceeding 650V.

### **Regulation 72. Earthing.-**

- (1) All metal supports and all reinforced and pre-stressed cement concrete supports of overhead lines and metallic fittings attached thereto, shall be either permanently and efficiently earthed by providing a continuous earth wire and securely fastening to each pole and connecting with earth ordinarily at three points in every km. with the spacing between the points being as nearly equidistant as possible or each support and the metallic fitting attached thereto shall be efficiently earthed.
- (2) Metallic bearer wire used for supporting insulated wire of overhead servicelines of voltage not exceeding 650 V shall be efficiently earthed or insulated.
- (3) Each stay-wire shall be similarly earthed unless insulator has been placed in it at a height not less than 3.0 metres from the ground.

### **Regulation 73. Safety and protective devices.-**

- (1) Every overhead line which is not being suspended from a dead bearer wire, not being covered with insulating material and not being a trolley-wire, is erected over any part of a street or other public place or in any factory or mine or on any consumer's premises shall be protected with earth guarding for rendering the line electrically harmless in case it breaks
- (2) An Electrical Inspector may, by notice in writing, require the owner of any such overhead line, wherever it may be erected, to protect it in the manner specified in sub-regulation (1).
- (3) The owner of every overhead line of voltage exceeding 650 V shall make adequate arrangements as per relevant Indian Standards to prevent undesignated persons from ascending any of the supports of such overhead lines which can be easily climbed upon without the help of a ladder or special appliances.

Explanation,- For the purpose of this regulation, rails, reinforced cement concrete poles and pre-stressed cement concrete poles without steps, tubular poles, wooden supports without steps, I-Sections and channels' shall be deemed as supports which cannot be easily climbed upon.

#### **Regulation 74. Protection against lightning.-**

- (1)The owner of every overhead line, sub-station or generating station which is exposed to lightning shall adopt efficient means for diverting to earth any electrical surges due to lightning which may result into injuries.
- (2)The earthing lead for any lightning arrestor shall not pass through any iron or steel pipe, but shall be taken as directly as possible from the lightning arrestor "without touching any metal part to a separate-vertical ground electrode or junction of the earth mat already provided for the sub-station of voltage exceeding 650 V subject to the avoidance of bends wherever practicable.

#### **Regulation 75.Unused overhead lines.–**

Where an overhead line ceases to be used as an electric supply line:

- i. the owner shall maintain it in a safe mechanical condition in accordance with regulation 57 or remove it.
- ii. The Electrical Inspector shall, by a notice in writing served on the owner, require him to maintain it in a safe mechanical condition or to remove it within thirty days of the receipt of the notice.

#### **Regulation 76. Laying of cables.–**

- 1) No underground power cable of voltage exceeding 33 kV shall be laid without a minimum under ground depth of 1.2 meters.
- 2) No underground telecommunication cable shall be laid without a minimum separation distance of 0.6 meters to the underground power cable of voltage exceeding 33kV.

#### **Regulation 77. Protection against electromagnetic interference.–**

The owner of every overhead power line of voltage level 11 kV or higher shall submit proposal for obtaining Power Telecommunication Co-ordination Committee clearance to ensure safety of the personnel and telecom equipment.

## Schedule

**Ground, Vertical and Horizontal clearances**  
[See sub-regulation (6) of regulation 58, sub-regulation (5) of regulation (60) and sub-regulation (5) of regulation 61]

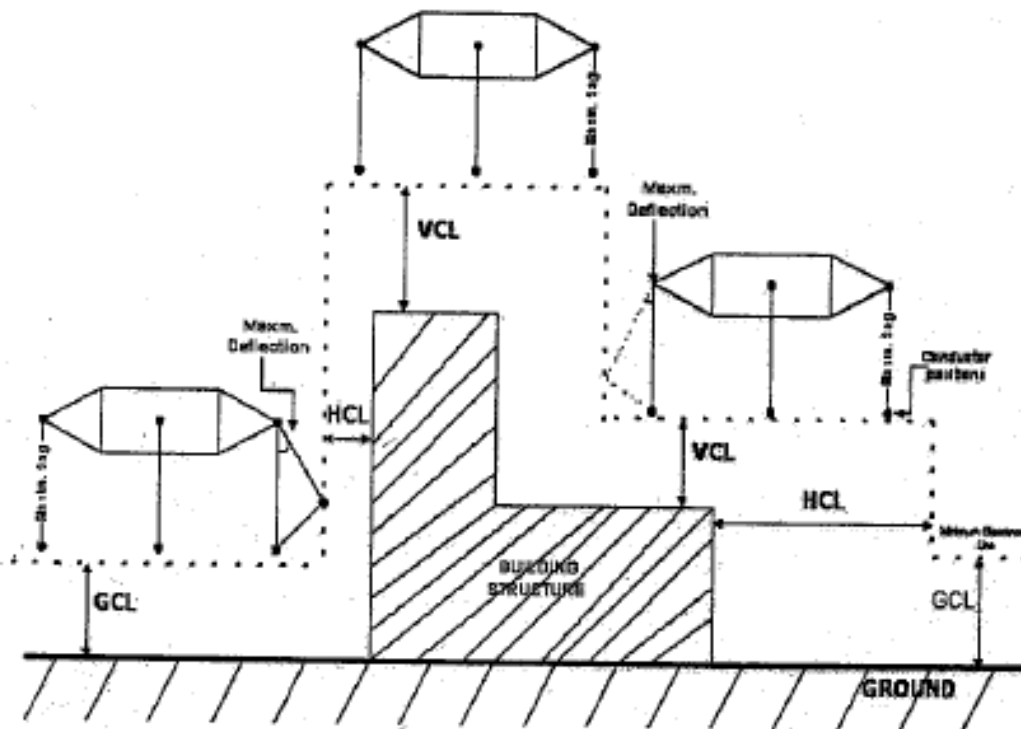

**GCL: Clearances as per Regulation 59**  
**VCL: Clearances as per Regulation 60 & 61**  
**HCL: Clearances as per Regulation 60 & 61**



# Prevention of Fire & Fire Fighting Techniques

Fire is the visible effect of the process of Combustion, releasing heat, light and various reaction products. In general the combustion or fire is a process involving rapid oxidation at elevated temperature accompanied by the evolution of heated gaseous products of combustion.

The discovery of fire, or, more precisely, the controlled use of fire, was one of the mankind's first great innovation which has made a breakthrough in his evolution. Controlled usage of fire / heat is essential in everyday livelihood of humans and many industries, at the same time if the fire becomes uncontrollable it leads to devastation of the life and property of him.

## Fire Basics :

A fire naturally occurs when fuel, heat and oxygen are present and combined in the right mixture, meaning that fire is actually an event rather than a thing. A Fire Triangle demonstrates the interdependence of these ingredients in creating and sustaining a fire.

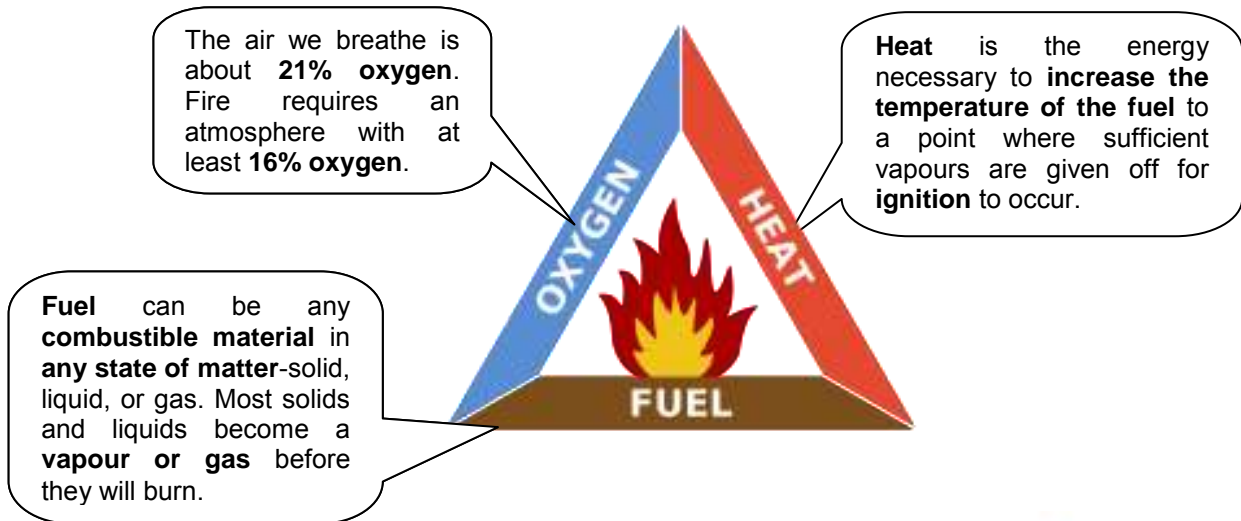

The combustion process can be more accurately represented by adding a fourth element in the above Fire Triangle called the 'chemical chain reaction'. This is the chemical process where fuel reacts rapidly with a source of oxygen to create fire i.e. burning.

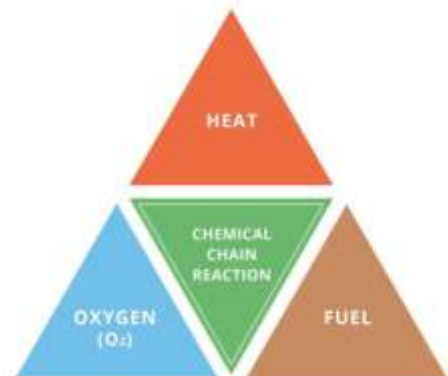

## Stages of Fire :

There are 4 stages of a fire, These stages are *incipient*, *growth*, *fully developed*, and *decay*. The following is a brief overview of each stage.

**Incipient** – This first stage begins when heat, oxygen and a fuel source combine and have a chemical reaction resulting in fire. This is also known as “ignition” and is usually represented by a very small fire which often (and hopefully) goes out on its own, before the following stages are reached. Recognizing a fire in this stage provides your best chance at suppression or escape.

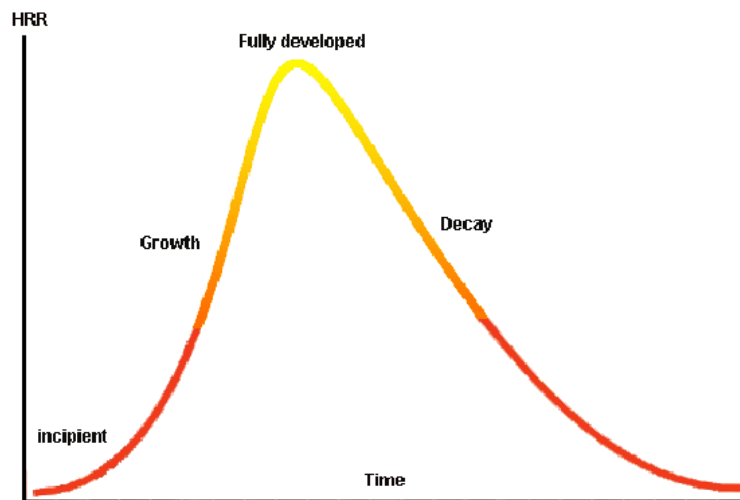

**Growth** – The *growth stage* is where the structures fire load and oxygen are used as fuel for the fire. There are numerous factors affecting the growth stage including where the fire started, what combustibles are near it, ceiling height and the potential for “thermal layering”. It is during this shortest of the 4 stages when a deadly “flashover” can occur; potentially trapping, injuring or killing fire fighters.

**Fully Developed** – When the growth stage has reached its max and all combustible materials have been ignited, a fire is considered *fully developed*. This is the hottest phase of a fire and the most dangerous for anybody trapped within.

**Decay** – Usually the longest stage of a fire, the *decay stage* is characterized a significant decrease in oxygen or fuel, putting an end to the fire. Two common dangers during this stage are first – the existence of non-flaming combustibles, which can potentially start a new fire if not fully extinguished. Second, there is the danger of a back draft when oxygen is reintroduced to a volatile, confined space.

## **Classification of Fire :**

All fires can be separated into 5 different categories, depending on the type of fuel that is burning. Categorising fires in this way makes it easier to choose the most appropriate method of fighting the fire.

### **Class A – Ordinary combustible fires**

These are probably the most common type of fire. They occur when materials become heated to their ignition temperature and will continue to burn as long as there is heat, oxygen and fuel to burn. Materials involved in these types of fires include paper, wood, textiles, rubber, some plastics and other organic carbon based compounds.

Class A fires are probably the easiest to extinguish as spraying them with water will cool the fire, removing the heat supply which is essential for the fire to burn. Water based or foam fire extinguishers are most appropriate for putting out ordinary combustible fires.

### **Class B – Flammable liquids**

Flammable liquids are those that have an ignition temperature of less than 100°C. These liquids also have a low flashpoint, which means that they burn easily. The flashpoint is the temperature at which a substance gives off enough vapour to be ignited. These liquids can however burn at any temperature if a source of ignition, such as a spark or naked flame is supplied.

Examples of liquids that are flammable include petrol, kerosene, alcohol, solvents and paints. Fires involving these give off a lot of heat and tend to spread very quickly. They also produce thick, black toxic smoke, which can make these fires difficult to fight.

The best approach for extinguishing a Class B fire is to use a foam fire extinguisher to smother the flames, as using water causes the fuel to scatter therefore spreading out the fire.

### **Class C – Flammable gases**

Flammable gases such as butane, propane and petroleum gases have the potential to create an explosion, if triggered by a single spark. For this reason flammable gases have to be stored securely in sealed containers. The LEL (lower

explosive limit) states the lowest concentration of flammable gas that will burn in air. This is usually around 5%, which shows just how big the danger is of potential explosions.

Fires involving flammable gases are one of the most dangerous types of fire to fight. Before attempting to put the fire out, you should make sure that the gas supply is isolated first. Most fire extinguishers are ineffective on Class C fires, the only type being suitable for use being dry power extinguishers.

### **Class D – Metal fires**

Certain metals and powdered metals can burn if ignited, although it requires a lot of heat to ignite most metals, as they are good conductors and transfer heat away quickly to their surroundings. Powdered metals and metal shavings are easier to ignite than solid lumps of metal, so pose a higher fire risk.

Alkali metals such as potassium, magnesium, aluminium and sodium can burn when in contact with air and water. Therefore putting water or foam onto metal fires will increase the intensity of the flames and result in potentially explosive reactions that will send pieces of burning metal in all directions.

In many cases with industrial fires where there are large amounts of burning metal, the safest approach is usually to let the fire burn itself out. As Class D fires tend to produce a lot of ash, this builds up and eventually starves the fire's Oxygen supply. If a metal fire is spotted early on, specialist type D powder fire extinguishers can be effective, although it should be ensured that they are the specific dry powder type, suitable for use on metal fires.

### **Electrical Fires**

Short circuits, overloaded switchboards, faulty equipment and damaged wiring can all cause electrical fires. Electrical fires are not strictly a fire class of their own, as electricity is a source of ignition as opposed to a fuel. They are still important to mention however as they have their own special fire safety requirements.

Before dealing with an electrical fire, the supply of electricity must be isolated as quickly as possible. **As water and foam has the power to conduct electricity, even once the electricity source has been cut off, you should not attempt to put out the**

**fire by putting water on the flames or by using foam and water based extinguishers. Carbon dioxide and dry powder fire extinguishers are the only types of fire extinguishers recommended for safely tackling electrical fires.**

### **Class F – Cooking oil fires**

Fires involving cooking oil and fats are common both in homes, businesses and professional kitchens. They pose a very difficult challenge to extinguish, due to the high temperatures involved. Simply trying to cool the fire with water will not work; in fact using water on a burning pan is likely to cause a rapid spreading out of the flames, making the fire worse and potentially injuring anyone in its vicinity.

For this reason special fire extinguishers have been developed to address Class F fires. Wet chemical extinguishers contain a formula which cools the fire and then emulsifies to seal the surface and prevent re-ignition.

### **Extinction of the fire**

A fire can be controlled and put out by disrupting the elements that form the Fire Tetrahedron for which we need to do one or more of these four things:

1. **Remove fuel sources.** This can be a preventative measure i.e. making sure potential fire hazards are stored safely or if a fire has started you can use water to disperse the fuel sources and to cool them.
2. **Cool the burning materials with water.**
3. **Exclude oxygen.** For example, with a fire blanket to prevent oxygen from reaching the process.
4. **Break the chemical reaction.** It is the chain reaction that keeps a fire going.

### **Different types of fire extinguishers :**

**There are different types of fire extinguishers for fighting various classes of fire.**

In the instance of a fire emergency, the last thing you want to be doing is reading the side of an extinguisher trying to figure out if you can use it to fight the flames. Being able to immediately distinguish them apart could make a lifesaving difference.

Fires come in many forms, so you need to familiarise yourself with how to properly and swiftly extinguish whichever type of fire you face.

Each type of fire extinguisher is ergonomically designed for the safe and effective discharge of its contents. They each contain different materials that make them suitable for fighting certain types of fires. The correct one must be used for the right class, otherwise they may prove ineffective or in fact aggravate the fire.

**Note :** None of the extinguisher mentioned below are suitable to deal with a large fire as all these are essentially first-aid fire-fighting appliances, however, these are very valuable, if used promptly and efficiently in the early stages of fire.

There are five main types of fire extinguishers:

1. Water
2. Powder
3. Foam
4. CO2
5. Wet chemical

Each type is easily identifiable by their names, colours, and sometimes their hoses; it's easier than you think to identify them from one another. Let's take a look at each type of fire extinguisher, their uses, and their risks.

## 1. Water

### Water extinguisher

These types of fire extinguishers will be solid red and will have the word 'water' printed across them. they dispense water at a high pressure to extinguish flames.

Water extinguishers are **only suitable for class A fires**, which means they can fight fires that involve wood, cloth, paper, plastics, coal, and other similar materials.

**Warning:** do not use on burning fat and oil fires and electrical appliances!



## Water spray extinguisher

These types of fire extinguishers will be solid red and have 'aqua spray' printed across them in white text. They are more effective at fighting fires than the traditional water ones because they spray water over a wider surface area and at a higher pressure.

Like its traditional counterpart, they **are only suitable for class A fires**.

**Warning:** do not use on burning fat and oil fires and electrical appliances.

Both water and water spray extinguishers can sometimes contain chemical additives that improve their effectiveness by up to 300%. The chemicals remove the water's natural surface tension so that it soaks into burning materials more effectively when used.

## 2. Powder

### ABC Powder Extinguisher (Dry Chemical Powder)

These types of extinguishers will say 'powder' in white text over a blue rectangle, and underneath the rectangle will be written 'ABC powder'.

As their name suggests, these are **designed to combat class A, B, and C fires** – those involving solids, liquids, and gases. The powder acts as a thermal blast that cools the flames so burning cannot continue. Due to their non-conductive nature, they are **also suitable for fighting electrical fires**. However, they do not effectively penetrate the spaces in equipment easily, so the fire could still re-ignite.

**Warning:** do not use on domestic chip or fat pan fires (class F).

**The downside to ABC powder extinguishers is that they pose a danger of inhalation** when used in close spaces. They also leave residue behind that is difficult to clean up and causes damage to soft furnishings, carpets, and computers.



### 3. Foam

These types of extinguishers are identifiable by the word 'foam' printed within a cream rectangle on their bodies. Foam extinguishers are primarily water based and contain a foaming agent, which has rapid flame knock-down and a blanketing effect – it smothers the flames and seals vapours so that re-ignition cannot occur. **They are suitable for fighting class A and B fires.**



When used against class A fires, the user can simply point and spray. However, when used against class B fires – those with flammable liquids – they should not be sprayed directly into the liquid. This could cause the fire to be pushed and spread to surrounding areas. The best method of application is to spray the foam nearby so that it can build up and flow across it.

**Warning:** these should not be used on any other fire classes, especially chip or fat pan fires. Most foam extinguishers will have had dielectrical tests performed on them, so foam is less hazardous than water if it is accidentally sprayed on live electrical equipment. However, they should still not be used to fight electric fires.

### 4. Carbon Dioxide (CO<sub>2</sub>)

These types of extinguishers can be identified by the text 'CO<sub>2</sub>' printed in white on a black rectangle. They also have a distinct type of horn like hose unlike other extinguishers.



Carbon dioxide extinguishers are **used for combating class B and electrical fires** – they suffocate the fire by displacing oxygen in the air. Because they do not leave any substances behind, unlike other extinguishers, they **are particularly useful for offices and workshops where electrical fires may occur** as they minimise damage done to equipment. . Also bear in mind that while carbon dioxide is effective at smothering fires, once the gas has floated away, the fire may re-ignite if the source has not been removed.



## 5. Wet Chemical

These types of fire extinguishers are identifiable by the words 'wet chemical' printed across a canary yellow rectangle. It also has an extended applicator.

Wet chemical extinguishers are **designed for combating fires that involve class F fires**. They are effective because they are capable of dissipating fires that are of an extremely high temperature – namely, cooking oils and fats.

### Other types of Fire Extinguishers

**Wheeled fire extinguishers** are also available, which have a greater capacity, volume, flow rate, range, and discharge time (not to mention the added convenience of not having to carry around a heavy canister in an emergency).



### What to do in the event of a Fire :

There are four essential steps which has to be followed in the event of discovery of fire, which is famously known by the acronym **R.A.C.E.**



1. **Rescue** anyone in the immediate danger area if you can safely do so.
2. **Activate** the nearest fire alarm pull station to activate the building fire alarm system. The fire alarm will sound throughout the building and notify others of the need

to evacuate. As soon as a person discovers a fire, he shall immediately intimate the control room or the shift-in-charge if the fire is in the Sub-station, or to the Assistant Executive Engineer / Executive Engineer O&M if the fire is in any O&M areas, as the case may be, giving exact information regarding the location, type and event of fire. The Operator / Shift-in-charge in the control room or the concerned engineers, after receiving the message of fire hazard shall inform immediately his immediate superior officer and the nearest available local fire brigade giving the exact information regarding the location type and extent of fire.

3. **Confine the fire** by closing doors (do not lock) to the fire scene and securing potentially dangerous substances and/or equipment.

4. **Extinguish / Evacuate** - If the fire is in the incipient stage then with the aid of available first aid fire extinguishers proceed to extinguish or control the fire with proper extinguisher until help arrives.

In case of fire involving electrical apparatus, the first step is to ensure the circuit is dead. Where it is not possible to switch off the current, the fire must be tackled in a way, which will not involve danger to the person, i.e by the use of non-conducting extinguishing materials i.e Carbon di oxide, Dry Chemical Powder, dry sand etc. Water should not be used on fires involving electrical equipments.

When extinguishing a fire known to have been started through an electrical fault, the current must, in any event, shall be switched off to avoid ignition.

If it is sensed that staying in the premises will pose danger then evacuate the building by the nearest or alternate exit if possible. Do not use elevators during an evacuation! Those who are unable to evacuate the building on their own should go to a stairwell landing and wait for evacuation assistance.

### **Procedure for Operation of Fire Extinguishers :**

In the event of a fire before proceeding with the decision of handling the fire with available fire extinguisher the following points must be ensured.

- Is the fire small enough and contained enough that you can put it out safely?
- Is a fire extinguisher available and within easy reach?
- Is the fire extinguisher of the proper type to put out the kind of fire you want to extinguish?
- Is the extinguisher fully charged and large enough to put out the fire?
- Have you been trained to properly use a fire extinguisher?

- Can you be certain that you won't be putting yourself or others at risk if you use the fire extinguisher to fight the fire?

Once the **type of fire is known** and selected an **appropriate fire extinguisher**, the next step is to use the extinguisher to put the fire out.

There's a simple, 4-step method which can be followed to use a fire extinguisher properly. The fire extinguisher steps method is known as PASS, and each letter in the word PASS (P, A, S, and S) stands for the first word of each step. The PASS method works for many common fire extinguishers.



## Pull :

Every fire extinguisher has a pin inserted into the handle that prevents the fire extinguisher from being discharged by accident. Grab the ring and pull the pin out from the side of the handle.

Now that the extinguisher is ready to discharge, hold the device so the nozzle is pointed away from you.



## Aim :

Move to the proper distance. Many fire extinguishers have a range of between 8 and 12 feet (2.4 to 3.7 m). Before discharging the extinguisher, move toward or away from the fire so you're standing 6 to 8 feet (1.8 to 2.4 m) (1.8 to 2.4 m) away. You can move closer once you start dousing the fire and the flames die down.

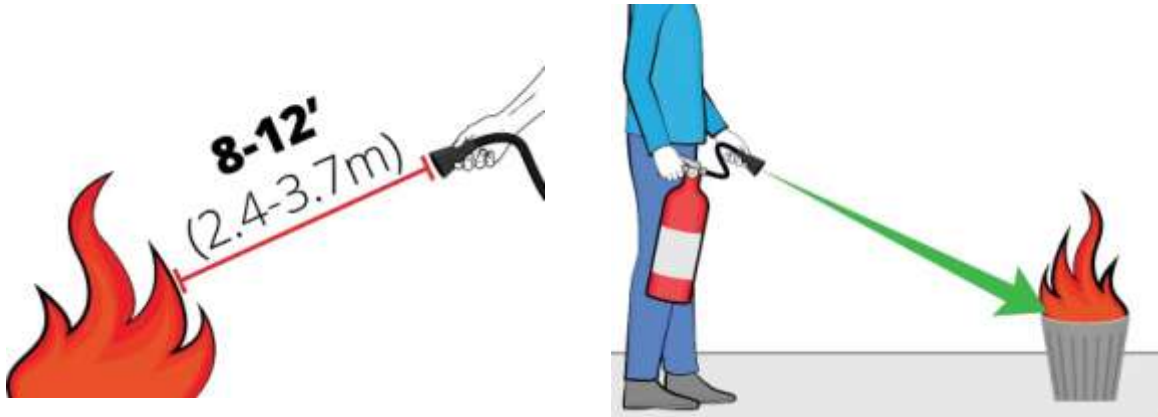

Aim the hose at the base of the fire. Hold the lower handle lever (the carrying handle) with one hand and grab the hose or nozzle with the other hand. Point the hose directly at the base of the fire, because you have to put out the fuel that's burning.

- Do not aim the hose at the flames. This isn't the fuel source, and you won't get much progress.
- With carbon dioxide extinguishers, keep your hands away from the plastic discharge horn, which gets extremely cold.

## Squeeze :

To release the extinguishing agent, squeeze the two levers together with one hand while you aim the hose at the base of the fire with the other. Apply slow and even pressure when you squeeze the levers. To stop discharging the extinguisher, release the levers.



## Sweep :

Sweep the hose from side to side. To extinguish all the fuel, slowly sweep the hose back and forth over the base of the fire as you discharge the extinguisher. Move closer to the fire as the flames die down. Continue discharging until the fire goes out. This includes any glowing embers, which can reignite.



Back away and repeat if the flames flare up. Watch the fire closely to ensure the flames don't flare up again. Back away slightly if they do. Aim the hose again, squeeze the lever, and sweep the hose across the base of the fire again to extinguish it. Never turn your back on a fire. You always want to be vigilant about where the fire is and what it's doing.



**Leave immediately if you're unable to extinguish the fire.** The average extinguisher will have enough agent inside to go for about 10 to 15 seconds. Back away and leave immediately if the fire isn't out when the extinguisher is fully discharged or if you don't have any other standby extinguishers.

**Evacuate a room that's filled with smoke.** Never try to fight a fire on your own if the room is full of smoke. Smoke inhalation can lead to unconsciousness, and you'll be stuck in the room with the fire. If there is lots of smoke in the room, cover your mouth and get down on the ground. Stay low to avoid the smoke and crawl out of the room to safety.

## Recommended Quantities of First Aid Fire Extinguishers :

The number and size of fire extinguishers required for any premises is determined taking into consideration the severity of incipient fire, characteristic of different materials in the building, the rapidity with which a fire may spread etc. Accordingly the number of fire extinguishers that has to be provided in the different buildings / areas of TANGEDCO is specified below.

Sl No	Type of First Aid Fire Fighting Equipment	Norm for Provision
<b>For 110 kV Sub - Station</b>		
a.	Foam type fire extinguishers (Trolley mounted) 45 litres capacity	1 No for a bank of 3 transformers
b.	Dry Chemical powder fire extinguishers (Trolley mounted) 22.5 kg	2 Nos. for a bank of 3 transformers
c.	Dry Chemical powder fire extinguishers (Trolley mounted) 10 kg	1 No for each Circuit Breaker limited to a maximum of 3 Nos. irrespective of voltage, class, category, type etc
d.	Dry Chemical Powder (Stored Pressure) fire extinguishers - 5 kg	2 Nos. for the Control room
e.	Dry Chemical Powder (Stored Pressure) fire extinguishers - 5 kg	2 Nos. for Carrier room located separately from control room
f.	Mechanical Foam Type (Stored Pressure) fire extinguishers – 9 litres	6 Nos. for the switchyard
g.	Fire Buckets – 10 litres – Sand	2 x 4 Nos. for the switchyard
h.	Fire Buckets – 10 litres – Water	4 Nos. for battery rooms with 110/220 v batteries.
i.	Half drums filled with sand	2 Nos. for yard.
<b>66 kV and 33 KV Sub- Stations, Indoor Sub-stations (33/11KV)</b>		
a.	Dry Chemical powder fire extinguishers (Trolley mounted) 22.5 kg	2 Nos. for a bank of 3 transformers
b.	Dry Chemical powder fire extinguishers (Trolley mounted) 10 kg	1 No for each Circuit Breaker limited to a maximum of 3 Nos irrespective of voltage,

SI No	Type of First Aid Fire Fighting Equipment	Norm for Provision
		class, category, type etc
c.	Dry Chemical Powder (Stored Pressure) fire extinguishers - 5 kg	1 No for the Control room
d.	Dry Chemical Powder (Stored Pressure) fire extinguishers - 5 kg	2 Nos. for the yard
e.	Mechanical Foam Type (Stored Pressure) fire extinguishers – 9 litres	4 Nos. for the yard
f.	Fire Buckets – 10 litres – Sand	4 Nos. for the yard
g.	Fire Buckets – 10 litres – Water	4 Nos. for battery rooms separately located.
h..	Half drums filled with sand	2 Nos. for yard.
<b>Capacitor Bank</b>		
a.	Dry Chemical powder fire extinguishers (Trolley mounted) 10 kg	1 No for each Bank of 1 MVAR or less.
<b>Indoor Sub-stations (11KV/433 V)</b>		
a.	Dry Chemical Powder (Stored Pressure) fire extinguishers - 5 kg	3 Nos. for the Control room and Transformer
b.	Fire Buckets – 10 litres – Sand	4 Nos.
<b>Offices</b>		
a.	Water Type (Stored Pressure) fire extinguishers - 9 Litres	1 for every 1000 sq. ft. area with a minimum of 2 Nos.
<b>MRT Laboratory ( Main Testing centre )</b>		
a.	CO <sub>2</sub> fire extinguishers 4.5 Kg	3 Nos
<b>MRT Laboratory ( Regional Testing centre )</b>		
a.	CO <sub>2</sub> fire extinguishers - 4.5 Kg	1 No
<b>Special Maintenance</b>		
a.	Mechanical Foam Type (Stored Pressure) fire extinguishers – 9 litres	3 Nos.

Sl No	Type of First Aid Fire Fighting Equipment	Norm for Provision
<b>Central Stores – Indoor Area</b>		
a.	Dry Chemical Powder (Stored Pressure) fire extinguishers - 5 kg	2 Nos.
b.	CO <sub>2</sub> fire extinguishers - 4.5 Kg	1 No
<b>Central Stores – Outdoor Area</b>		
a.	Water Type (Stored Pressure) fire extinguishers - 9 Litres	3 Nos.
b.	Fire Buckets – 10 litres – Sand	4 Nos.
c.	Half drums filled with sand	4 Nos.
d.	If Transformers in stock  Mechanical Foam Type (Stored Pressure) fire extinguishers – 9 litres	3 Nos.
<b>Sub Stores – Indoor Area</b>		
a.	Dry Chemical Powder (Stored Pressure) fire extinguishers - 5 kg	2 Nos.
b.	CO <sub>2</sub> fire extinguishers - 4.5 Kg	1 No
<b>Sub Stores – Outdoor Area</b>		
a.	Fire Buckets – 10 litres – Sand	3 Nos.
b.	Half drums filled with sand	2 Nos.

### **Selection of Location for Fire Extinguisher :**

When selecting locations for fire extinguishers, due consideration should be given to the nature of risk to be covered. The extinguisher should be placed in conspicuous positions and shall be readily accessible for immediate use in all parts of the occupancy.

Generally, fire extinguishers should be placed as near as possible to exits or stair lands without hindering the escape routes. It should be placed in such a way that these shall readily be seen by persons following the natural impulse to get out of danger.



The extinguishers should be available for immediate use at all times. It should be sited in such a way that the user may not have to travel more than 15 m from the site of the fire to reach the extinguishers. Similar position on each floor are advisable.

When installed in a building, the extinguisher should not be placed in a position where it is likely gain heat from the surrounding equipment, process or direct Sun rays.

### **Inspection & Maintenance of Fire Extinguisher :**

Periodic inspection of fire extinguishers shall include a check of at least the following items.

- Location in designated place.
- No obstruction to access or visibility
- Operating instruction and nameplate legible and facing outward.
- Safety seals and tamper indicators not broken or missing.
- Fullness determined by weighing or lifting.
- Examination of obvious physical damage, corrosion, leakage or clogged nozzle.
- Pressure gauge reading or indicator in the operable range or position and
- Condition of tyre, wheels, carriage, hose and nozzle checked (for wheeled units)

The fire extinguishers must be maintained periodically as specified in the **Indian Standard IS 2190 (2010) : Selection, Installation and Maintenance of First-Aid Fire Extinguishers – Code of Practise**. Also all the fire extinguishers must be procured, maintained and operated as specified in the Indian Standards stated below.

- IS 6234:2003 – Portable fire extinguishers, water type (Stored Pressure) – Specification (First revision).
- IS 15397 : 2003 – Portable fire extinguisher mechanical foam type (Stored Pressure) – Specification.
- IS 13849, 4308 – Portable fire extinguisher Dry Chemical Powder type (Stored Pressure) – Specification.
- IS 10658 – Specification for higher capacity Dry Chemical Powder type fire extinguisher (Trolley mounted).
- IS 2878 – Portable fire extinguisher CO<sub>2</sub> – Specification.

# First Aid

First aid is simple medical treatment given as soon as possible to a person who is injured or who suddenly becomes ill. This is usually effected by a lay person and performed within a limited skill range. First aid is normally performed until the injury or illness is satisfactorily dealt with or until the next level of care, such as a paramedic or doctor, arrives. First aid may help the person to survive till the doctor comes and saves his/her life.

The key guiding principles and purpose of first aid which govern all the actions undertaken by a first aider is.

- Prevent further injury
- Preserve life
- Promote recovery

In order to provide safe and effective assistance at the scene of an emergency working in a logical and planned manner is essential. Depending on the situation it may be needed to send for emergency help before going near the scene.

In the event of an accident the initial steps which has to be taken are

- Turn off the source of electricity, if possible. If not, move the source away from you and the person, using a dry, non conducting object made of cardboard, plastic or wood.
- Keep the affected person lying down in a comfortable position, his head in level with his body. This will prevent him against fainting.
- Severe Haemorrhage ( Blood Loss) must receive immediate attention, no matter what other injuries are present.
- If the Breathing is ceased, immediate measures must be taken to restore it. The victim should be in a position to breath freely. Breathing supply Oxygen which is essential for life. Oxygen is circulated throughout the body by Blood. If Oxygen does not get in to the brain for more than about Three Minutes, brain tissues begins to die. Hence breathing must be restored immediately.
- When the Victim has fractured bone, no attempts must be made to move him until the bone has been made immovable.
- Never give water or liquid to an unconscious patient.

Once the incident is under our control then need to think about handling of the casualty. The steps involved in handling of the casualty is famously known by the acronym **DRABC**.



**D – Danger.** Your priority when you are trying to help someone in a situation should always be to remain safe and avoid causing any injury to yourself or others. Look and listen for signs of potential risks before you start to treat the unconscious person. If the area isn't safe, move away from the danger and call 108 or 101 (Fire Service).



**R – Response.** You now need to assess how responsive the casualty is and if they are conscious. The first step in this stage is to loudly ask a simple question, such as “Hello, can you hear me?” If they answer clearly, then they are alert and you can move straight on to the last stage of the action (Circulation).

If they don't respond verbally, try asking another question in a loud voice close to their ear, such as “Can you open your eyes?” If there isn't any movement of the eyelids, then give them a firm pinch on both shoulders. If the casualty isn't alert, this generally indicates that the person needs immediate medical attention, so an ambulance should be called.

If the casualty is unresponsive to your voice, or a firm pat or a pinch on the shoulder, then they are unconscious. If there are other people present, tell one of them to ring for an ambulance. If there isn't anyone to help you, shout for assistance as loud as you can.

**A – Airway.** In order for the casualty to breathe, they need to have a clear airway. If they are unconscious, the tongue can become floppy and fall to the back of the throat, blocking the airway.

The airway can be opened by placing two fingers under their chin and your other hand on their forehead. You then gently tilt the head back and lift the chin. While the casualty's head is in this tilted position, their tongue will be away from the back of their throat. The head will need to be held in this position, so keep your hands on the forehead and the chin, or enlist a bystander to help.



Also it has to be checked for the presence of any foreign substance in the mouth which may obstruct the airway. If any foreign substance is present then it has to be removed by tilting the head sideways

**B- Breathing.** Once the airway is clear you need to establish if your casualty is breathing normally. The easiest way to check this is to lower your head to the level of their face and look down their body, from their head to their feet.



In this position you will be able to see if their chest is rising and falling, while listening for breathing and seeing if you can feel the movement of their breath on your cheek. You should hold this position for not more than ten seconds.

If your casualty is unconscious, but breathing normally, you can move on to the final step – circulation. If the casualty is unconscious and not breathing you should immediately start cardiopulmonary resuscitation (CPR). It's important to only move on to the next stage when you are sure that the casualty is breathing normally. No time should be wasted in starting CPR.

**C- Circulation.** Once you have checked that the casualty's airway is clear and they are breathing normally we have ensure the circulation of the blood by checking the pulse. In case of emergencies to check for the hear beat, Carotid Pulse has to checked. This pulse can be felt by placing the finger tips gently on the voice box and sliding them down into the

hollow between the voice box and the adjoining muscle. The normal pulse rate per minute on an average is 72. Count the pulse rate for 10 seconds, if it is other than 12 to 14, it may be abnormal.



Once circulation is confirmed then we need to look for signs of major blood loss. If there is any external bleeding, apply pressure to the area and if the bleeding is from a limb, raise the affected arm or leg above the level of the heart.

Injuries or conditions that result in severe bleeding, internally or externally, can be life threatening because of the risk of shock. It's possible that the casualty may have internal bleeding, so the casualty should be monitored for signs of shock.

If the unconscious person is breathing normally and is showing no signs of severe bleeding or shock, then all you need to do is keep their airway open by placing them in the recovery position.

## **The Recovery Position**

A person who is unconscious is at risk from dying because of a blocked airway. In most cases turning the casualty into the recovery position can prevent this. Before turning the casualty into the recovery position, remember to carry out the appropriate steps in DRABC. The steps involved in bringing the victim into recovery position is.

### **Step - 1**

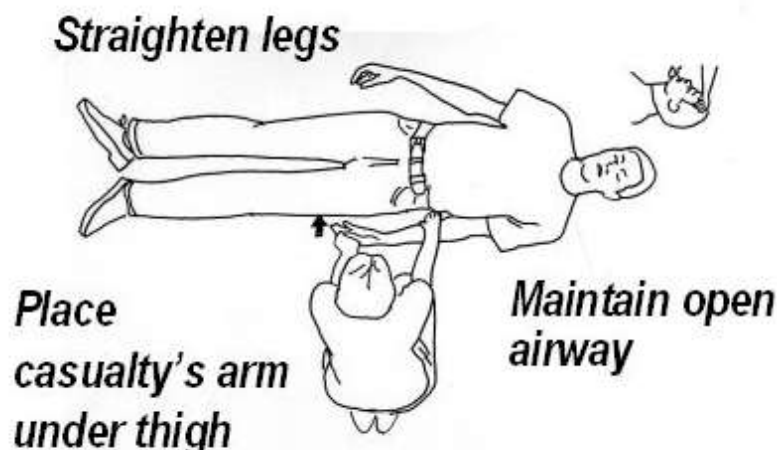

**Step – 2**

***Pull far leg  
towards you***

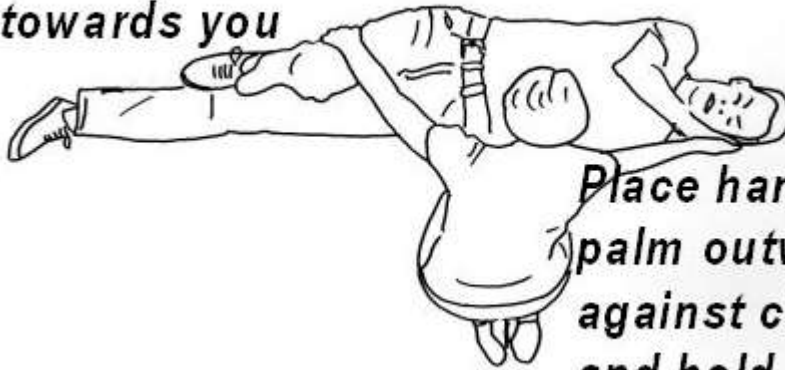

***Place hand -  
palm outwards  
against cheek,  
and hold it there***

**Step – 3**

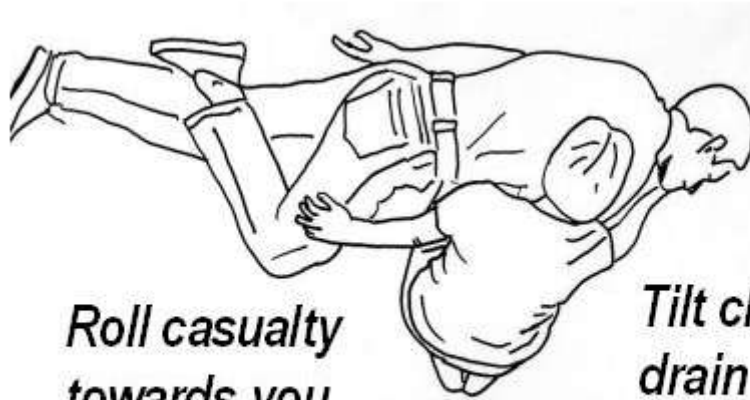

***Roll casualty  
towards you***

***Tilt chin to  
drain  
mouth***

**Step – 3**

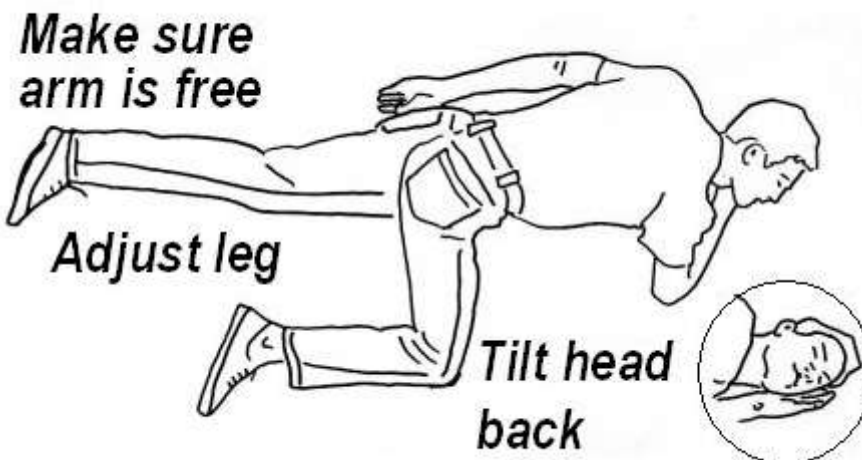

***Make sure  
arm is free***

***Adjust leg***

***Tilt head  
back***

## **FIRST AID FOR ELECTRIC SHOCK :**

An electric shock occurs when a person comes into contact with an electrical energy source. Electrical energy flows through a portion of the body causing a shock.

The danger from an electrical shock depends on the type of current, how high the voltage is, how the current travelled through the body, the person's overall health and how quickly the person is treated.

An electrical shock may cause burns, or it may leave no visible mark on the skin. In either case, an electrical current passing through the body can cause internal damage, cardiac arrest or other injury. Under certain circumstances, even a small amount of electricity can be fatal.

A person who has suffered an electric shock may have very little external evidence of injury or may have obvious severe burns. Burns are usually most severe at the points of contact with the electrical source and the ground. The hands, heels, and head are common points of contact.

In addition to burns, other injuries are possible if the person has been thrown clear of the electrical source by forceful muscular contraction. Consideration should be given to the possibility of a spinal injury. The person may have internal injuries especially if he or she is experiencing shortness of breath, chest pain, or abdominal pain. Pain in a hand or foot or a deformity of a part of the body may indicate a possible broken bone resulting from the electric shock causing violent muscle contraction.

Affected individuals should be examined for entry and exit marks to help determine the extent of the electric shock. Some individuals may suffer a cardiac arrest after electric shock (they may not have a pulse or be breathing).

If an individual is unconscious, not breathing and with no pulse after an electric shock it may be a Cardiac Arrest, immediately start with Cardio Pulmonary Resuscitation (CPR). The procedure for CPR is stated below.

## Cardiopulmonary resuscitation (CPR)

Cardiopulmonary resuscitation (CPR) consists of the use of chest compressions and artificial ventilation to maintain circulatory flow and oxygenation during cardiac arrest

In October 2010 the procedure / guidelines for performing CPR has been revised within an objective to make it easier for rescuer and health care providers alike to learn, remember and perform better CPR. New CPR guidelines advises to go for Chest Compressions immediately, instead of opening the victim's airway and breathing into their mouth first. The sequence in Revised CPR is

### **STEP – 1 : Begin Chest Compressions**

If the victim is not breathing, place the heel of your hand in the middle of his chest. Put your other hand on top of the first with your fingers interlaced. Compress the chest at least 2 inches (4 – 5 Cm). Allow the chest to completely recoil before the next compression, relaxing the pressure on the chest between compressions allow the heart to refill and pump more blood. Compress the chest at a rate of at least 100 pushes per minute. Perform 30 compression at this rate.



### Proper Techniques for Chest Compressions.



**If you are not trained in CPR, continue to do chest compressions until help arrives or the victim wakes up. Its normal to feel pops and snaps when you first begin chest compression – DON'T STOP !! you're not going to make the victim worse.**



**STEP - 2 : Open the Airway.**

After 30 compressions, open the victim's airway using the head-tilt, chin-lift method. Pinch the victim's nose and make a seal over the victim's mouth with yours. (use a cpr mask if available).



**STEP - 3 : Begin rescue breaths.**

Give the victim a breath, just enough to make the chest rise, Let the chest fall, then repeat the rescue breath once more.. If the chest doesn't rise on the first breath, reposition the head and try again. Whether it works on the second try or not, go to step 4.

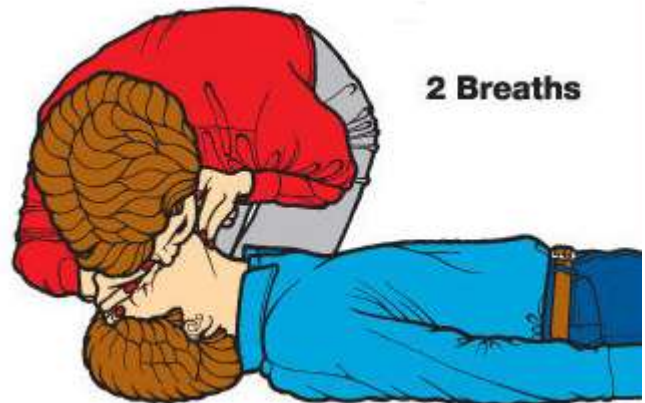

**STEP - 4 : Repeat Chest Compressions.**

Repeat chest compressions. Do 30 more chest compressions just like you did the first time.

**STEP - 5 : Repeat Rescue breaths.**

Repeat rescue breaths. Give more breaths just like you did in step 3 (unless you're skipping the rescue breaths). Repeat steps 4 and 5 for about two minutes ( about 5 cycles of 30 compressions and 2 rescue breaths). This can be continued till medical help arrives or the victim wakes up.

# Accident Reporting and Auditing

## Why Reporting Necessary ?

- We ought to try our best to learn from the experience of others, rather than to learn the hard way and we must pass on to the generation a record of what we have learnt.
- Critical review and recommended measures to avoid recurrence of such accidents could be possible only on reporting of accidents.
- From the point of elimination, causes (un safe conditions and unsafe actions) could be analyzed so as to issue circulars to promote safety consciousness and awareness among field staff of our Organization.
- In short reporting is basically needed to minimize the accident rate by way of deep study as to inculcate safety mind among the staff.
- To reduce the compensation loss towards accidents (met by the organization)

## Investigating the Accident Spot :

- All fatal accidents departmental and non - departmental other than due to bonafide cases of suicide, Inquisitive climbing etc, should be investigated by Executive Engineers concerned.
- Bonafide cases of suicide of inquisitive climbing fatal accident and all serious non - fatal accidents to both departmental and non - departmental persons should be personally Investigate by AEEs concerned.
- Non - fatal accidents of minor nature may be investigated by the section officer concerned.
- All human fatal accidents to departmental and non- departmental persons should be personally investigated by concerned Superintending Engineers of the circle.
- All accidents of electrical nature should be investigated by the Electrical Inspector concerned.
- All departmental and non - departmental accidents in connection with TANGEDCO in the region area should be investigated by the Safety Engineer.

- If departmental electrical accident occurred the investigation officer at the accident spot should acquire the Line Clear book used in the site.
- Exhibits to be examined and taken as evidence by the investigating officer.
- A neat sketch showing the site of accident with all details, if electrical accidents electrical layout of the site should also be furnished.

#### Reporting :

- The accidents as and when occurred shall be intimated to SE/Chairman's office by the territorial EE's concerned immediately after inspection of site by fax / e-mail / Telegram / SMS and ensure the same has been received.
- The preliminary report shall be submitted on the same day of occurrence of the accidents and in any case within 24 hrs of such occurrence by the EEs and an interim report from SEs within 2 days.
- The detailed report shall be submitted within 7 days from the date of occurrence of the accident by the SE / EDC concerned
- The Chief Engineers shall critically review the accidents and furnish their reports upon receipt of detailed report from SEs / EDC
- Copies of all the reports shall be sent to SE / Chairman's Office. CE / Personnel, CE / Planning & RC, SE / RE&I(D), Director Distribution.
- CEs must instruct the SEs / EDCs and EEs to send the accident reports within the stipulated time.
- Action taken on staff responsible, DPs to be initiated and punishment given should be reported to CE/ Personnel on action taken within two months.

#### **Details to be accompanied with report :**

- Victims doing just prior to the accident and at the moment of accident.
- Manner in which accident occurred.
- The nature of injury suffered
- Action taken by the witnesses, co - workers or supervisory staff (first aid, medical facilities extended and arranged steps to remove the cause of accident).

## **Enclosures should be accompanied with the report :**

- Statement of persons who met non - fatal accident.
- F.I.R. or social work register acknowledgement from police official
- Post - mortem or medical certificate from the concerned medical authority.
- Statement of persons assisting the person killed or injured / Supervisory staff statements.
- Neat Layout showing the accident spot.
- Witness Statement.

**( All the forms Related to Accident Reporting is in Annexure – III of this manual )**

## **SAFETY AUDIT**

- The Prime purpose of safety Audit is to curb out any possibility of an Accident.
- The safety Audit involves finding out the possible reasons and preventive measures for an accident.
- It involves verification of works carried out in the field / SS as to whether the safety measures are adhered properly by the workmen and properly exercised by the concerned supervisors.
- For effective safety Audit, a committee comprising of the following members from the Distribution Circle shall be formed by the Superintending Engineer.
  1. An Executive Engineer from the Circle.
  2. An Assistant Executive Engineer
  3. An Assistant Engineer/ Junior Engineer I Gr.
  4. A special Gr. Foreman / Foreman I Grade.
- If A Safety officer of Assistant Executive Engineer / Assistant Engineer is posted to the Circle, then they may be nominated instead of Sl.No (2) or (3).
- The above committee will be for a period of 12 months and after 12 months the members may be nominated afresh in the same cadre as above
- The above committee shall inspect the work locations randomly and surprisingly in any section of the Circle

- The Committee shall investigate the work with respect to safety aspects viz, Whether allocation has been made on the job allocation register, LCP availed or blink obtained / switch opened / earthing done / PPEs used or not.
- The facts and shortcomings if any shall be recorded in the format in triplicate and serve one copy of the same to the Supervisor or workmen under whose supervision the work is being carried out.
- The 2<sup>nd</sup> copy will be submitted to the Superintending Engineer concerned within 5 working days from the Audit
- Depending on the degree of severity of the non- compliance of safety procedures necessary action may be taken on the erring supervisor and / or workmen as deemed fit.
- The committee shall inspect at least 12 locations in a year.
- If the same deficiency is found repeated for another time the punishment shall be high.
- If during the time of inspection the working team is adhering Safety rules / regulations in an excellent manner, then appreciation may also be done.
- Concerned Superintending Engineer shall take appropriate action to disseminate the information on the formation of Safety Audit Committee to the down level with the reward / punishment system.
- The activities of the Safety audit committee shall be reviewed periodically by the Superintending Engineer Concerned.

**( Form Related to Safety Audit is in Annexure – IV of this manual )**

## LINE CLEAR PERMIT

- Line clear are permits issued for working on lines or equipments which are in service but disconnected from supply for carrying out any work. They should be in the form prescribed for this purpose.
- Every Line clear permit shall be issued by a person authorized by the competent authority . And also every line clear permit shall be issued to a person authorized in this regard.
- Every working party (team) should have a separate line clear from the authorized person entitled to issue.
- Under no circumstance work must be done by one team taking approval from another party who has received line clear.
- More than one Line clear can be issued on the same line or equipment for different person.
- Generally not more than one line clear shall be issued to a single person at one time. Only after return of the previous line clear availed by him / her the next line clear should be issued to the same person. However under unavoidable circumstances when a second Line clear is required it may be issued to the same person subject to the condition that the safety of the working personnel is ensured properly and the entire responsibility lies with the receiver of the Line clear.
- Even though the line or equipment is defect and out of service or line breakdown, a separate line clear shall be obtained by the person who is going to rectify and he should be authorized in this regard.
- The person authorized to issue LC shall carryout the Operations first viz, tripping of breaker, opening of isolator, providing of earth etc, and then write the LC to issue it and this should not be done in the reverse..
- The person who has availed line clear shall not go anywhere except the work spot, and it is his responsibility to caution the entire person who has engaged in the work.

### **Special cases :**

- When an authorized person who has taken a Line clear for the work on a line or equipment is to leave the place of work, due to emergency he should arrange another authorized person to take another line clear for the very same work and there after return this line clear and then only leave the spot. The reason for return of LC shall be specifically mentioned.
- No column in the LC shall be left blank.
- In case if the original line clear permit is misplaced due to extreme circumstances the person who received the line clear shall report the same in writing to the issuing authority and give an undertaking to the effect that the line / equipment is free and safe for energisation. This shall not be entertained often and such incidents shall be allowed as a special case after getting concurrence from the competent authority only.

### **SELF LINE CLEAR**

- Where the person to work is the same as the person to isolate the line or equipment, then he shall issue and receive a self line clear in writing and follow the same procedure while returning.
- The Officers in charge shall verify randomly whether Self LC has been availed in the above circumstances.
- In LT Distribution network also the person who is going to work on the network shall mandatorily follow the self LC without fail.

### **LINE CLEAR BOOKS**

- Line clear permit books shall be treated as important records.
- A separate file shall be maintained for the returned & cancelled Line clear permits.
- Duplicate copies shall be taken with carbon paper only.
- If any leaf of the LC book is found torn out, that should be accompanied with a statement with dated initials of the person responsible for maintenance of such records.

## **OBTAINING LINE CLEAR OVER PHONE**

- During certain occasions it may not be possible for an authorized person to avail line clear in person. On such circumstances Line clear may be issued over phone.
- In such cases the messages shall be repeated by the person who received the line clear message and shall be confirmed by the sender of the message to ensure that book are quite clear. The fact that the message was repeated and confirmed shall be recorded in the LCP Books by the sender & receiver respectively. Both the sender & receiver shall be authorized persons and they should be able to recognize each other's voice for issue & receipt of Line clear permit. The Phone No. from which the person is speaking should be recorded.
- If the receiver is not an identifiable person then the issuer may ask for an authorization from the Officer concerned for identification and also for his phone No.

## **AUTHORIZED PERSONS**

- Any work in the TANGEDCO which involves handling of live Electrical equipments, lines etc, shall be taken up only when the person attempting the work / entrusted to carry out the work has the authorization in this regard either by virtue of holding the post or by specific authorization. The level of authorization based on designation is tabulated below.

<b>Sl.No</b>	<b>Designation</b>	<b>Network on which authorized to avail Line clear permit</b>	<b>Remarks(Requirement of specific authorization if any)</b>
1	Officers at the level of Assistant Engineer / Junior Engineer & above	at all levels of voltages (EHV / HV / MV / LV)	They can avail LCP by virtue of their designation, subject to their area of jurisdiction
2	Junior Engineer Gr-II	on HV system only (up to and including 33 KV only inside the Substation	by virtue of their designation. They may avail LCP on EHV system only on specific



SI.No	Designation	Network on which authorized to avail Line clear permit	Remarks(Requirement of specific authorization if any)
		premises)	authorization from the competent authority.
3	Spl.Gr Foreman/ Foreman/ Line Inspector	on HV system only	by virtue of their designation subject to their jurisdiction only
4	Wireman	on 22KV,11KV, MV & LV system.	For availing LCP on HV system of 33 KV special authorization to be obtained based on his level of competency limited to specific case
5	Field Assistant	For operation of HV system only.(Opening & Closing of AB switches only). LCP can be availed on MV / LV system only	By virtue of his / her designation.

- All Level of the above Authorized person should be conversant with safety precautions / procedures / Regulations pertaining to their area of Jurisdiction.
- The competent Authority may cancel the authorization in case if the above requirements are not complied with.
- The revocation may be made after satisfactory compliance is ensured by the Authority concerned.
- A list of authorized persons to carry out the specified work shall be clearly exhibited in each section wise and also available at the sub station from which their authorized area is supplied with electricity.

**The following works are to be carried out only by the Authorized persons.**

- 1) Issue / receipt of line clear on lines / equipments.
- 2) Discharging / Earthing of equipments / lines.
- 3) Operation of AB switches & Isolators when they are in service and with supply.
- 4) Providing / renewal of HG fuses in the HT side of Distribution Transformer.
- 5) Carrying out the following type of works in the lines / equipments of which the voltage does not exceed 650V.
  - a) Replacing street lights.
  - b) Renewal of fuses on poles / LT side of distribution transformer.
- 6) Testing of consumer's installation and giving service connection on LT side.
- 7) Connecting / repairing of Electrical motors, time switches etc on LT side.
- 8) Operation, maintenance, testing & supervision of works on Electrical lines / equipments.

**Note: Line clear must be issued by the person on whose control the lines / equipments are available.**

- Suppose a line is declared as Break down, the line may feed 2 or more sections. In such an occasion, the opening of the sectionalizing switches towards the next section will be done by the authorized person of First section and closing of the switch should be done by authorized person of the 2<sup>nd</sup> section only. The opening & closing of the sectionalizing switches shall be with the concurrence of the section officer concerned in normal cases, and the opening & closing shall be informed to the concerned section officer after having done so, in case of emergencies like Break downs.

**Special Authorization**

Where ever persons of lower rank have to perform the duties not authorized to him, special authorization may be given by the Executive Engineer of the Division, on the basis of proper recommendation by the concerned officer based on his / her competency level.

Before consideration for special authorization, the following should be taken in to account.

- 1) The reason for giving special authorization should be justifiable.

- 2) The person for whom the special authorization is to be given should have adequate knowledge to carry out the work and should have sufficient experience.
- 3) The special authorization should be for a particular person and not for the post. Further it is valid for a particular period only after which it has to be revalidated.
- 4) The special authorization should indicate the area of work distinctly.
- 5) The person should be well acquainted with the feeding arrangements in that area.
- 6) In accordance with the CEA regulations, it should be ensured by the authorizing officers that all the authorized persons are acquainted with and competent to apply the instructions regarding treatment of Electric shock and all the methods of Artificial respiration system.

**Procedure for issue of line clear :**

- 1) Line clear should be issued by authorized person to the authorized person only to receive it.
- 2) Line Clear must be issued only upon receipt of prescribed Line clear application in complete shape. ( **Format of application specified in Annexure – 1** )
- 3) Before issue of line clear:
  - a. Specific approval from the competent authority to carry out normal scheduled works should be obtained
  - b. For emergency nature, the same shall be informed to the competent authority.
  - c. Even though prior approval for scheduled work is available, the LC shall be issued only based on the condition prevailing on the particular day of work.
  - d. The equipment or line shall be isolated from the supply and it should be ensured that there is no back feeding on the equipment / line.
  - e. The person issuing the line clear shall personally see that the isolator or AB switch blades are opened fully. They shall be locked in the open position or in “OFF” position.
  - f. After personally confirming the switch is in OFF condition, and after putting the key in the line clear board for safe custody, then every one of the conductors or the respective equipment shall be tested for voltage or charge by a discharge rod. The discharge wires shall be kept at least 0.75 meters away from the person doing the work of discharge.

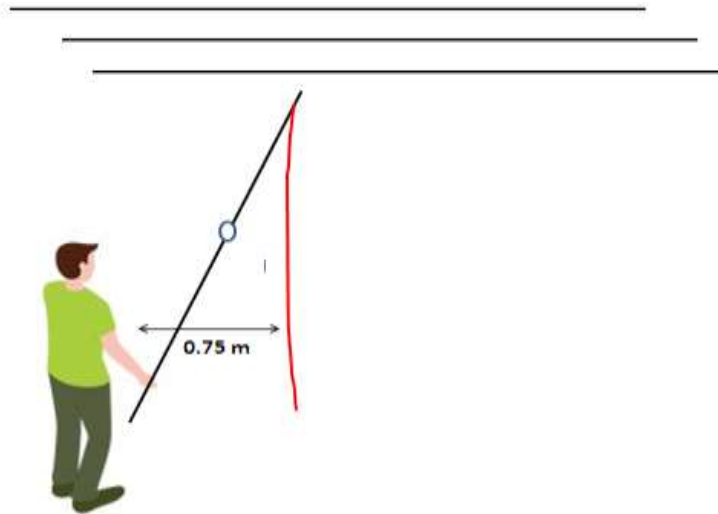

- g. Then all the conductors be shorted together and adequately earthed on the outgoing side of the switch / isolator. Using of Rubber gloves or gauntlets shall be mandatory for discharging and earthing.
- h. While issuing LC on Lines, generally earthing is made on Line side and the earthing leads are connected to the earths available inside the Substation premises which will be connected to Earth mats. But to avoid appearance of dangerous voltage due to Transfer potential, the receiver of the LC must be advised to provide earths compulsorily at the work spot and it shall be clearly mentioned in the LC.
- i. Caution board as “Men on line” “Do not switch on” to be placed on the isolator.



- j. All operation in connection with the issue of line clear should be done by the person issuing LC or under his immediate presence on the site and as per his / her directions only.

- k. After the above operation are carried out. The line clear form shall be filled up correctly without corrections. And no column in the form shall be left blank. Corrections / over writing should be attested with dated initials and No of corrections / over writings should be indicated specifically. The issuer shall sign in the LC with date & time and also the receiver shall sign in the LC with date & time in the appropriate place.

**Procedure to be followed for Receiving of Line clear :**

- 1) Any person requiring a line clear on any line or equipment shall apply in writing to the competent authority, specifying clearly the portion of line / equipment, where supply to be cut off and nature of work to be carried out.
- 2) He shall follow the operations carried out by the official issuing LC and ensure that isolation, discharging, earthing etc, are properly carried out. Then only he shall sign in the permit form except LC over phone.
- 3) At the work spot, he shall test the line or the equipment on which he has received the LC permit, with discharge rod and then earthing shall be done on either side of the work spot. This is mandatory.
- 4) If the work on a line/ equipment involves the possibility of the line / equipment coming in to contact with the other line / equipment, or crossing the line a separate line clear must be taken on those lines / equipments from the person who is competent to issue line clear on those line / equipments.
- 5) The person who has availed the line clear shall record on the line clear form, the No of persons who are attending the work. Then only he should begin the work.

To start with the work, the following are to be observed.

- 1) Identification of permitted areas.
- 2) Identification of danger zones.
- 3) Test for back feeding.

**Identification of permitted area:**

Caution boards like MEN ON LINE; DO NOT SWITCH ON, UNDER BD, UNDER LC, etc, to be placed on the breakers / switches to identify the permitted area.

### **Identification of danger zones:**

When the adjacent equipment to the permitted zone is live, then a rope around the live equipment shall be belted with at least 1 manila rope and on which a red flag with cotton shall be tied to identify the danger zone.

The ladders to be used shall be fixed on the equipment where LC has been issued, so as to avoid unnecessary confusion.

### **Return of line clear .**

The following are to be observed on return of line clear .

- 1) The authorized person who received the LC only shall return it.
- 2) He shall personally see the line, equipment etc are free from men, materials and any earthing devices or shorting devices etc. Further it shall be ensured that the works carried out are completely satisfactory to the point of normal operating condition and it will not affect or alter the routine system. If at all any change is made then it shall be informed to the concerned.
- 3) All the men working shall be informed by the person who has availed the LCP that the line clear permit is being returned and they must be made to understand that working in the above line / equipment will no longer be admitted and not safe for work.
- 4) The equipment / line shall not be charged until all the line clear permits are duly cancelled.

**The following rules shall be adhered to when a line clear is returned before charging the line / equipment.**

- 1) The returned LC shall be examined and ensured that all the necessary certificates are furnished for the entire satisfaction of the operating person.
- 2) "Caution Boards" shall be removed from the equipment / switch controlling the lines.
- 3) It should be ensured that there is no other LC is pending to be returned on the particular / line.
- 4) It shall be examined at the supply point for men material & earth, and that may be removed and then only the line shall be energized.
- 5) It shall be checked for

- 1) The condition before the issue of LC.
  - 2) Equal voltage on the equipment / line
  - 3) Unusual noise.
- 6) The fact shall be informed to the person who has availed the LC.
- 7) After the line / equipment is energized and normal operating condition is restored, then only the members who worked on the LC shall leave the place.

## **RECEIPT OF BLINK**

- BLINK is intended for carrying out Switching Operations only and not a permit to work
- The receiver of the BLINK shall be authorized by the section Officer concerned.
- The section Officer either by a written message or by phone request for a BLINK on a particular feeder
- If it is by phone an OTP may be sent to the Section officer by the Operator and the OTP shall be communicated by the Section Officer to the Operator so that the blink will be issued
- In case the Blink is authorized to some staff in that Section then the OTP may be sent to that staff on request by the Section Officer.
- On receipt of the OTP the staff authorized may contact the Operator of the SS and telling the OTP received to the operator and request for a blink.
- The receiver shall clearly communicate the exact feeder on which the blink is required and duration of the blink. At any case the blink shall not exceed 15 minutes.
- After switching operation is over, the receiver of the blink will contact the Operator to normalize the feeder,
- Again to check the identity, the operator shall send OTP to the number from where the blink is obtained.
- After receipt of OTP the receiver of the blink can inform the OTP to the operator and then only the feeder will be normalized.
- At no case the operator shall not energise the feeder unless there is a communication is received from the receiver of the blink.

## Accidents – Case Studies

### NEAR MISS ACCIDENTS

Description	Unsafe action	Unsafe condition	Suggestions to avoid such accidents
<p>One Line inspector , contacted a sub station operator over his Mobile phone and requested a blink on the Town feeder of the substation in order to rectify a glow in the AB switch of a DT which is located after the DP (sectionalizing switch), for which a blink is necessary and sufficient to open the DP (AB switch). The Operator at the substation in turn accepted his request and told the LI , that the breaker is under trouble in opening.(ie) whenever the breaker is opened, it automatically closes after some time say 5 to 10 minutes and the spl.mtce team is coming to rectify the defect. Hence the operator told him that he will trip the feeder, open the bus side &amp; Line side isolators and will call back. After some time The LI reaches the work spot where he planned to open the DP, waiting for the call from the operator. After the receipt of call from Operator about the Blink, with Gloves on Hands, Shoes on legs opened the AB switch, but due to the availability of supply on the line, the insulators flashed over with heavy sound, jumpers cut with heavy arc. After recovering from the situation, he rushed to the SS, and quarrelled with the operator that the mistake is on the part of the Operator. But the Operator said, that he was at duty right from morning to till such time and nobody has contacted for a blink and he has not given any blink to anybody. At that time, a call from nearby SS received by the Operator and the other SS operator told that, the LI, received a blink before 2 hrs and he has not confirmed the opening of AB switch. Then only</p>	<p>The action of the LI without ascertaining the work is unsafe.</p>		<ol style="list-style-type: none"> <li>1) The BLINK shall be issued only on specific authorization from the competent authority.</li> <li>2) The person who is requesting BLINK shall be asked to specify the location of work etc, for confirmation by the Operator.</li> <li>3) The Feeder name shall accompany the name of the town instead of mere “Town feeder” or “Industrial feeder” or “Waterworks” feeder.</li> <li>4) The Latest updated Section wise staff list shall be available at the Substation feeding that Section areas.</li> </ol>



Description	Unsafe action	Unsafe condition	Suggestions to avoid such accidents
<p>everybody including the LI has realized that the BLINK was wrongly requested by the LI at that SS instead of this SS. On detailed enquiry the LI told that he has dialled the number of the SS which was stored already in the old thought, since the LI was working there upto last 2 months and he came on transfer to this section recently 2 months back.</p>			
<p>One wireman has to set right the jumper loose connection at a pin point location on the 2nd pole of the DT. For that the wireman Opened the DT and confirmed that all the blades have opened. Then he climbed on that particular pole and commenced the work. That DT was located in a remote rural location in an open area. By the time Cows and bullocks wandering there came nearby the DT and accidentally one bullock's horn was locked in the AB switch's hole where the operating pipe to be inserted. In an attempt to remove the horn from the hole the bullock turned its head here and there and thereby energizing and de energizing the DT repeatedly. the wireman saw the bullock from the pole and he got down from the pole in a hurry. Fortunately nothing happened to the individual as he ascertained the situation before hand</p>	<ol style="list-style-type: none"> <li>1) The wireman has not locked and tagged out the switch</li> <li>2) No fuses has been removed</li> <li>3) No earthing has been provided</li> </ol>	<ol style="list-style-type: none"> <li>1) The hole in the AB switch became large due to operation with crowbars</li> <li>2) No fencing was available and hence easy access to animals</li> </ol>	<ol style="list-style-type: none"> <li>1) Fencing to DT shall be made to avoid other's access</li> <li>2) Whenever Switches are opened it shall be locked and tagged out</li> <li>3) Any work shall be carried out by proper earthing only.</li> </ol>

Description	Unsafe action	Unsafe condition	Suggestions to avoid such accidents
<b><u>Departmental Accidents</u></b>			
<p>One staff has under taken a work of replacing a failed DT. He has isolated the HT/LT supply to the DT. In order to provide earthing at location prior to the work spot, He has climbed the pole (HT/LT) at which Two feeders are meeting (Two feeders' junction).The previous span has not been made dummy. Without making the prior span dummy, he tried to have a grip for his hand at the LT three Phase cross arm and got electrocuted. Immediately he fell down and died on the way to hospital.</p>	<p>1)He has not ensured the non- availability of supply in the location where he is about to provide earth.</p> <p>2) He has not used the safety waist-belt rope.</p>	<p>The location is a LT 2 feeder junction, where one span on one side has not been made dummy.</p>	<p>1) All the two-feeder junctions should have one dummy span on previous span.</p> <p>2) If he has used the safety waist-belt rope, the accident may not end in fatal.</p> <p>3) Before providing earth rods on the line if the rods are touched with the line with earthed end, then the availability of supply will be ensured.</p> <p>4) Taking self-LC should be made as a mandatory practice.</p> <p>5) "DANGER" BOARD and "TWO FEEDER JUNCTION" caution Board should be displayed, to make alert the workman before taking up the work.</p> <p>6) The poles having 2 feeder junction may be painted in RED.</p>
<p>A wireman was residing at a Staff Quarters. On "Pongal" Festival day one 11KV feeder declared Break-down. The feeder was feeding the loads at the staff quarters. As there is</p>	<p>1) He has not confirmed his action and there is no synchronization between</p>	<p>1) The D.P. which he opened had no name board for the</p>	<p>1)All the D.P (Sectionalizing Switches) may be provided with "Name Board" of the</p>

Description	Unsafe action	Unsafe condition	Suggestions to avoid such accidents
<p>no supply, he contacted the Sub-Station and confirmed the feeder is under Break-down. On proceeding to the next step, (i.e.) opening the D.P (Sectionalizing), he had opened the DP, but of the other feeder which is healthy one and not at all related to the feeder which is under Break-down. He got electrocuted and his life becomes fatal.</p>	<p>his thought and action. 2) Over confidence of the individual.</p>	<p>identification of the feeder. 2) He has operated the handle from inside the paddy field (Wet area).</p>	<p>feeder to which it is feeding. And also a "DANGER BOARD" should be placed to avoid confusion. 2) If should be ensured all the necessary safety measures are taken before commencement of any work (belt rope, rubber gloves in good condition, discharge rod etc).</p>
<p>An efficient Foreman, the recipient of the II nd prize for the "Best Performer" in the distribution circle met with an accident. He had under taken a work an attending break down in a 11KV feeder in the odd hours, (around 2.00 AM) he is alone and no supporting person to him. He has rushed to the location of a D.P. Switch, where it needs to be closed for restoration of supply. He left his moped TVS 50 in running condition with head light 'ON' to provide illumination to the location. He made an attempt to close the AB switch of the D.P. Unfortunately he was electrocuted and thrown away, due to the contact of AB switch flexible copper jumper on 'B' phase with tandem pipe of AB switch. The neighbour of the area came there and he rushed away to the hospital .But in vain he died on the way to the Hospital.</p>	<p>1) On the AB switch , the flexible copper on the 'B' phase knife was cut open and made in touch with the tandem pipe of the 'AB switch' hence causing unsafe condition. 2) Poor lighting in that area. 3) Poor earthing or (unearthed).</p>	<p>1) He has not thoroughly examined the entire DP for any abnormality before making an attempt to close the AB switch. 2) He has not accompanied by any one supporting person for assistance such as providing lighting or torch etc. 3) He has not used any safety appliances like. (Gloves)</p>	<p>1) If the structure metal parts are earthed in an effective manner, then the feeder will not hold with such a faulting zone. (Copper flexible cut) 2) As for as possible the sectionalizing D.P, may be provide in an area with sufficient illumination (near street light location or any service installation). 3) In extreme case, at least one person should accompany so as to provide Assistance like giving illumination with torch light etc. 4) Priority should be given on the maintenance of AB switches of the</p>

Description	Unsafe action	Unsafe condition	Suggestions to avoid such accidents
			<p>Sectionalizing area and should be ensured for correct closing &amp; easy opening.</p> <p>5) Whenever the flexible jumpers are cut it shall not in any case made good with binding by conductors, but be rectified by lugs intended for it.</p>
<p>A wireman, had received information about the non availability of electricity in a Distribution Transformer, at about 10.00PM in the night, which is feeding essential services like, Govt. Hospital, Transport Corporation, Fire station, Telegraph office etc. He had reached the spot and found the HG fuses blown out He has opened the AB switch and climbed on the DT, without noticing the non- opening of blades in two phases attempted to renew the HG fuses, got electrocuted and positioned on the seating channel in dead condition.</p>	<p>1) The closing &amp; opening of AB switch was improper.</p>	<p>1) The wireman has not ensured the complete opening of all the three blades in the AB switch.</p> <p>2) He has not discharged / earthed the work spot.</p> <p>3) He has not used the Belt-Waist-Rope.</p> <p>4) No self LC was taken by him.</p>	<p>1) At all times it should be ensured whether all the blades of the AB switch are opened fully and there is no abnormality in the structure.</p> <p>2) Before commencing any work the spot should be discharged &amp; earthed.</p> <p>3) Necessary safety appliances, like, gloves, waist belt rope etc. Should be used irrespective of whether it is minor / major work.</p> <p>4) Taking self LC should be made as a practice and habitual.</p> <p>5) No hurry should be there while attending such sort of works.</p>

Description	Unsafe action	Unsafe condition	Suggestions to avoid such accidents
<p>A wireman of distribution section had been accompanied with the Foreman and LI of the section on the task of attending a Breakdown on 22KV feeder. After replacing a defective pin insulator in a DT, they have preceded further to energize the feeder. The D.P is situated in an elevated place, and the wireman had taken up the task of closing the AB switch with gloves in hands and chapels in the foot. The LI was standing at a location away from the DP at about 5 feet which is wet and water logged, and he is without any footwear. When the wireman closed the AB switch of the DP, the outgoing jumper on Y phase cut and fell down on the AB switch frame, causing flashover of the insulators. During this time the fault current while passing through the AB switch frame to earth also passed through the bare foot of the LI and he gone to the unconscious stage and at a later time he died at hospital. The wireman who closed the AB switch was also admitted to the hospital and he became normal only after three days of treatment in the hospital.</p>	<p>The LI was standing in a location where water logged and also without any footwear.</p>	<p>1) The sectionalizing DP switch is situated in as elevated place, and around that place there is water logging area like paddy field.</p>	<p>The sectionalizing switches may be erected in a place where there is no water logging like paddy field, tank, water catchments area. Further it should be easily accessible: underneath the structure should be spread with jelly so as to minimize the step potential, and effective earthing should be ensured. Further during charging or opening no one should stand under the lines.</p>
<p>In a distribution section a fuse of call at an Agriculture SC was registered at about 5PM on a day. The same was noticed by the area wireman of that section. On the next day morning about 6.30AM the wireman went to the Agl. SC where he was about to attend the fuse of call, on his two wheeler, switched off a distribution transformer, nearer to the Agl.SC which is not at all related to this SC, climbed on the LT pole and sit on the cross arm. When he attempted to set right the connecting wire, he was electrocuted and his body was lying on the LT lines itself. On shouting by Wireman, the service owner and others have switched off the supply to the Agl.SC by opening the respective transformer.</p>	<p>1) The Agl.SC was fed by a transformer which is away from the SC instead of a DT which is nearer to it. Due to this every one may come to an opinion that the DT is feeding this Agl.SC.</p>	<p>1) The wireman has not well versed with the feeding arrangement on the distribution.  2) He has not ensured the non availability of supply, where he is going to work.  3) He has not discharged / earthed the portion where he is going to work.  4) He has not availed</p>	<p>1) Availing self LC should be made mandatory and it should be brought habitual.  2) As far as possible the SC may be connected on a DT which is nearer to avoid possible un wanted prediction. Or the DT from which the line is fed may be marked in paint in the pole it self.  3) Safety appliances like gloves, discharge rods, should be used</p>

Description	Unsafe action	Unsafe condition	Suggestions to avoid such accidents
		self LC.	Scrupulously. 4) Before doing any work, the feeding arrangements should be clearly studied and ensuring of non-availability of supply is essential.
<p>It was proposed to energize a new distribution transformer. The works were carried out by construction &amp; Improvement wing. The Foreman of the Distribution section was already on leave. Further the Line Inspector could not be contacted since he had been engaged in another work outside. A Helper when returned to office after attending some work had been asked to accompany the AEE &amp; AE for the work of energisation of a New DT, by Departmental Jeep. When they got down, the AEE &amp; AE have gone to ensure whether the HT Jumpers were put in a proper manner. Another Foreman of construction wing was also there on the spot and instructed the Helper to connect a bulb on the LT bus of the new transformer which is going to be energized, so as to ascertain the supply through the burning of the bulb. But the construction staff had already energized the LT Bus through Back feeding from the nearest DT in order to give supply to the existing Agl. SC. temporarily until the feeding arrangements are altered. This has not been informed to the O&amp;M staff by the construction wing. The Helper while made an attempt to drop a bulb in the LT Bus got electrocuted and he was laid on the bus itself in dead condition.</p>	<p>The LT Bus was already energized through back feeding without information to the concerned O&amp;M staff.</p>	<p>Though it is a new DT to be erected, the safety practice of discharging &amp; earthing has not been done by the Helper.</p>	<p>1) If a work is carried out by construction wing, the back feeding arrangement should be carried out only with the knowledge of the O&amp;M staff, that too in writing. 2) Discharging &amp; earthing should be made mandatory &amp; habitual.</p>
<p>One Helper was working in an 110KV grid SS in shift duty. Previous night he was in night shift and in the morning also he continued the shift to avail compensation leave so as to</p>	<p>No unsafe condition is observed.</p>	<p>Thiru. Govindan has carried out the work with tiredness, due to</p>	<p>Staff should not be permitted to continue the work / duty without</p>

Description	Unsafe action	Unsafe condition	Suggestions to avoid such accidents
<p>enable him to leave for his native. He has not taken any food in the morning. The Technical Assistant on the shift duty climbed the structure and was examining the spot of the glow in the switch end clamp after availing Proper LC. The Helper also followed the Technical Assistant and climbed the structure. After reaching the top of the bottom structure, He tried to tie him with the use of belt rope, he slipped and fell down on the ground met with the fatal accident. And there were no external causes to this accident</p>		<p>continuous shift and no food intake.</p>	<p>refreshment or food</p>
<p>A wireman was at his work in disconnecting the services which are default to pay the CC charges. He opened the AB switch of the DT and then went to the tail end of the DT where disconnection has to be made. On an attempt to make a disconnection at the pole, he was electrocuted and fell down and his life end in fatal. On a detailed enquiry it was informed that the AB switch was closed by some unknown person.</p>	<p>There is no lock and key arrangement at the AB switch</p>	<p>1) The Wireman has not earthed the work spot even it is a small work. 2) He might have placed a board "MEN ON LINE: DO NOT SWITCH ON".</p>	<p>1) Provision of Ariel fuses. 2) Lock &amp; key arrangements or an escort for the AB switch. 3) Earthing at work spot may be made as a habitual practice.</p>
<p>A staff was doing the load bifurcation works (Connecting up the new loads). He has climbed on a pole, where there is HT line on the top &amp; LT line on the bottom. Having opened the DT feeding the LT loads and with supply on the HT, (Top) Though he is aware of having HT supply in the top portion, he made contact with the HT line without knowing him, due to concentration on work. He fell down and life ends in fatal</p>	<p>1) There is no LC permit has been availed on the HT feeder. Live on top of the pole. 2) No departmental staff is available to supervise the labor. 3) The clearance between HT &amp; LT is inadequate.</p>	<p>1) He has not used the belt-rope. 2 He has taken no cautious action to do the work care fully, since he is fully aware of the availability of the HT supply.</p>	<p>1) As far as possible the services should not be emanated from the HT &amp; LT poles. 2) There should be a clear identification of HT &amp; LT. 3) Necessary guarding arrangement should be made so as to avoid accidents. 4) Sufficient clearance should be given between HT &amp; LT. 5) In this case, LT line</p>

Description	Unsafe action	Unsafe condition	Suggestions to avoid such accidents
			works might have been completed when the HT line was under LC.
<p>A wireman has attempted to renew the HG fuses in a DT. He had already been in the night duty at Fuse of Call center at the office. On return to his residence, he was informed that the area has no supply where the DT is located. Normally whenever a complaint is received, any two persons will go for the spot to rectify, considering the safety and nature of work. He is attending the work of renewing the HG fuses which were already blown out. During this course of time, the HT jumper in fixed contact of R phase has cut and made in contact with the blade of Y phase AB switch, and supply is available in the HG fuses stool also. The attempt without safety appliances resulted in fatal end of him</p>	<p>HT R phase jumper in fixed portion made in contact with the Y phase blade causing unsafe condition.</p>	<p>1) He has not watched condition, above the AB switch. 2) He has not used the safety appliances belt-rope, earth rode etc.</p>	<p>1) Whenever giving jumper connection it should be ensured that, in case of any cut in the jumper, it should not make contact with any of the parts. 2) Even in the removal of HG fuses it should be done with proper safety precautions and also with safety appliances. (Earth rods, discharge rods, and belt-rope). 3) As for as possible, these sort of works should be attended by at least two persons.</p>
<p>In a 110/22 KV Substation, the Buchholz relay in the Power Transformer acted, and there is no supply in the area fed by the SS. In order to restore supply, a team from spl.mtce was deputed. Gas or Air collection was noticed. Instead of collecting the gas from the cock of the relay, a person of the team made an attempt to go for naked flame test by lighting a match stick (which is very dangerous and not in practice, but this is being followed in many places) and due to the flammable gas present in the Buchholz relay the Power transformer got fired and end in fatal of 2 lives.</p>	<p>The attempt of naked flame test by the staff</p>		<p>1) Non-standard practices shall be curtailed. Gas Collection shall be made first and shall be tested in a separate location free from hazards. 2) Necessary Gas collection equipment shall be available at Spl.mtce and it shall be ensured by the circle level officer.</p>



Description	Unsafe action	Unsafe condition	Suggestions to avoid such accidents
			3) Necessary monetary powers shall be enhanced for easy procurement. 4) Necessary chemicals like silver nitrate solution shall be made available.
<p>An efficient foreman of a distribution section has entrusted the work of dismantling of 10 spans of LT 3 phase 4 wire line, between 2 nos. distribution transformers to 4 contract labours.</p> <p>The description of the work:</p> <p>1) 10 spans of line (3 phase LT wire) are to be dismantled due to energisation of a new distribution transformer.</p> <p>2) Providing one permanent stay where the dismantling process ends. To enable to carry on with the above works both The Distribution Transformers were switched "OFF", in the presence of the Foreman and hence there is no supply in the LT lines which are to be dismantled. There was a crossing of 11 KV HT line above the LT lines between poles No. 5 &amp; 6 (span no 5) and there was no guarding at the HT line. The clearance between the HT &amp; LT line is only 2 feet. The HT line was not switched off. The Foreman went to the Sub-station for availing LC. 2 Contract labours have dismantled the lines up to pole no 4 and then they climbed on pole 5 &amp; 6 respectively. There was no work on pole No. 7 to 10 and the conductors remain unchanged. One TCL who is on pole no 5 had released the 2 phases on one side of the pole on the cross arm. On the other side another TCL was doing the same work on pole no 6. As soon as the first person released 2 conductors from pole no 5, the conductor raised up and touched the HT line above the LT line where the work was under progress. Both were electrocuted. Both of them have used the waist- belt – rope &amp; foot step wood. Thiru Ramasamy had recovered from the shock but Thiru Mahesh</p>	<p>1) They have not discussed about the work to be carried out.</p> <p>2) While doing such sort of dismantling / renewal of conductors, the work on the LT cut point should be carried out at the final stage. This has not been followed.</p> <p>3) When dismantling conductors, initially the conductors on the extreme ends of the cross arm should be released first, then the immediate conductor to the pole. This was also not followed.</p> <p>4) While releasing of conductors the already released conductors may be tied up with one end of "1/2" Manila rope and the other end tied to a support so that on releasing from the cut point the conductor will not rise up and touch</p>	<p>1) No competent departmental persons to supervise the work.</p> <p>2) No line clear was taken on the HT feeder</p> <p>3) No guarding for the HT line and the clearance between the HT &amp; LT line was low.</p>	<p>1) Contract labor should not be allowed to work without proper supervision.</p> <p>2) When there is a crossing with HT line &amp; other live lines the supply on the other lines are also to be switched off and a line clear to be availed.</p> <p>3) Necessary guarding / clearance to be provided on crossings.</p> <p>4) Dismantling of line should be done systematically as discuss in item 2, 3, 4 of the above Para.</p> <p>5) Necessary temporary stays should be provided where it is necessary.</p> <p>6) When such type of works is carried out, another person may be deputed for check &amp; cross check.</p>

Description	Unsafe action	Unsafe condition	Suggestions to avoid such accidents
died at site.	the HT line.		
<p>On a particular day it was programmed to paint colour for the poles on HT line. But due to non availability of line clear permit on that 11 KV feeder, a contract labour was allowed to paint the poles on the LT lines after switching "OFF" the Transformer. In the meantime the section officer &amp; the Foreman have left the spot to avail LC on the HT feeder where it was originally programmed to paint. The contract labour continued to paint the poles on LT lines. He has painted all the LT poles pertaining to be transformer and also painted the next LT Pole which was made dummy. The next pole to the dummy span is having LT supply fed from another Transformer. Without noticing the above, the contract labour climbed on the pole, got electrocuted and died.</p>	<p>1) Without proper earthing Thiru Rajan has climbed on the pole for painting. 2) No waist – belt – rope has been used by the painter. 0.</p>	<p>1) There is no supervision at all. 2) Thiru Rajan was not informed of the availability of supply in the LT Pole. 3) Self LC not availed. 4) No earthing made at work spot.</p>	<p>1) Responsible supervisory persons should be made available for such work. 2) Taking of self LC should be made mandatory. 3) Earthing &amp; discharging should be done properly. 4) Safe zone &amp; unsafe zone should be indicated by flags at work spot. 5) Insisting of using safety devices as belt rope etc.</p>
<b><u>Non Departmental Accidents</u></b>			
<p>A farmer with 3 Acres of land has cultivated Sugar cane in his field. On one day he allowed water to stagnate inside the sugarcane field and made an "Electric fencing" around the field to prevent the "FOX" from destroying the field. When he came out of his field, he himself electrocuted, due to came in touch with the Live fencing.</p>	<p>Live Wire fencing is dangerous since nobody can easily find out that there is a fencing .</p>	<p>Laying Electric fencing itself is an unsafe action and is punishable under IPC section 336 and as per section 139 of "THE ELECTRICITY ACT-2003"</p>	<p>Public should be made aware of the Evils of the Live wire fencing. Wide propaganda will ease the situation.</p>
<p>A non-departmental person had been asked to attend a defect of non-burning of lights in a domestic service by the</p>	<p>1) HT / LT line both are in a single pole of in</p>	<p>1)As he is an unauthorized person he</p>	<p>1) Public should be informed not to engage un-</p>

Description	Unsafe action	Unsafe condition	Suggestions to avoid such accidents
<p>owner of the Service. He ascertained that the fault is with the over head LT line, and switched OFF the AB switch of the Transformer pertaining to the LT line. The pole is also having a HT line on the Top of the LT 3 phase 5 wire line. The clearance between HT and LT line was about 1.0 meter and no guarding was provided. During the course of work, He stood up in the LT 3 phase cross arm and made contact with the HT line above through his Head, got electrocuted and died at the spot itself</p>	<p>adequate height.(24'). 2) No caution Board for HT / LT crossing has not been placed. 3) No Guarding had been provided.</p>	<p>should not have attempted to carry out this work. 2)He has taken no precautionary measures.</p>	<p>authorised persons for such Works. 2) Whenever HT / LT lines are run 30 feet poles should be used to have adequate clearances. 3) A Caution Board should be displayed for HT / LT lines on same supports. 4) Proper Guarding arrangements should be made.</p>
<p>A farmer had been to his sugarcane field for watering from the electric pump set in the early hours. Due to falling of a branch from the morning tree on the three phase 4 wire line leading to the above pump set, one phase wire snapped down on the ground inside the sugarcane field. Due to come in contact with the snapped wire. he was electrocuted with injuries and char marks on left leg, chest, forehead and right arm. Even after treatment, he was not able to recover and died after two days. During this incident the fuses on the LT side have not blown out.</p>	<p>1)Thiru. Damodharan, without knowing the snapping of the conductor has entered the field for watering. It was ascertained that the sugarcane waste after cutting were burned by the farmers under the electric line, which may also a reason for losing the mechanical strength, such that a branch of Morning tree will cause snapping of conductor.</p>	<p>1) The conductor might have snapped due to low clearance as the line was passing through sugar cane crops. 2) The snapped conductor was hanging inside the field without giving a close loop to the circuit, such that the fuse was not blown.</p>	
<p>A Lady aged about 35 years, was going to the River to take a bath. There was one LT 3 phase 4 wire lines across the river leading to an Agricultural Service through a coconut farm situated before the crossing of the river without any Guarding on the crossing portion. Due to heavy wind on the pervious</p>	<p>1)Touching of the snapped wire by the victim unnecessarily.</p>	<p>1)Snapping of Live wire on the ground. 2)LT line crossing the river without any guarding.</p>	<p>1)The LT line crossing might have been avoided as it will pose to so many operational inconveniences to the operating personnel</p>

Description	Unsafe action	Unsafe condition	Suggestions to avoid such accidents
<p>day the branches of some coconut trees fell on the 3 phase 4 wire line and thus caused the snapping of one of the conductors and the snapped portion fell inside the River area. She on her way to River found the snapped wire and touched with her right hand. She was electrocuted with char marks on her right hand, died on the spot.</p>			<p>also. For e.g. in a case of attending any work on the line or service connection on the other side of the River the operating personnel has to switch off the Transformer which is placed on this side. This will be a time consuming operation and unsafe also. Instead the line may be fed from some other Distribution Transformer which warrants no river crossing.</p> <p>3)If the crossing is unavoidable, necessary and suitable guarding and earthing device arrangement should be made so as to disconnect the supply in case of such occurrences.</p> <p>4)Public also should be informed and awareness may be created that they should not touch the fallen wires if they found. Further the contact phone Nos. of the nearest Electricity Board Office should be displayed in prominent places such as Distribution Transformer structures, some poles, etc. so that public can easily</p>

Description	Unsafe action	Unsafe condition	Suggestions to avoid such accidents
			inform such abnormalities to the concerned officials. Further the public may be educated not to let any person to touch the fallen wires until the Electricity Board officials / staff reaches the spot.
<p>A business man has constructed a new house underneath the 11 KV line emanating from the nearby 33 KV substation, even after the warning notice issued by the concerned Section Officer for the in adequate clearance. On one day his son aged about 14 years was playing in the roof of the newly built house. As the clearance between the 11 KV line and the roof was inadequate, the boy incidentally got in touch with the line and received heavy shock, hence shouted. On hearing his shout, a neighbour rushed through the stairs to save the boy from the crisis, but he also accidentally got in touch with the HT line and electrocuted. Both were brought down with the help of a ladder and hospitalized. The neighbour, expired at the Hospital and the boy was not able to walk due to internal system malfunction.</p>	<p>1)The boy had been to upstairs for play and touched the line accidentally.  2)The neighbour also acted emotionally, but without intelligence.  3)The neighbour had not acted safely to protect the boy.</p>	<p>1)The Vertical clearance between the 11 KV line and the roof was inadequate.  2)Having known about the inadequate clearance, the owner has not closed the way to the Up stairs.</p>	<p>1) Statutory and safe clearances should be followed scrupulously followed so as to avoid accidents and loss of lives.  2) Public should be informed of such incidents.  3) Such accident prone areas are to be identified and precautionary measures to be taken.</p>
<p>On one particular night there was heavy wind and rain due to which so many trees have fallen down. In this particular case a thorny tree have broken and fell down on the LT 3 phase 4 wire line leading to an Industrial service connection. Due to the weight of the tree acting upon the line, the stay wire was pulled out from the position, the pole at the service end leaned and broken away with supply. The wires were hanging inside the tall maize crops.</p> <p>The next day morning a girl passed through that way touched the live hanging wire through her left arm, shocked again fell down on the entire wire electrocuted with char marks on her body. During that time the LT fuses of the concerned Distribution Transformer were blown out. There</p>		<p>Due to falling of thorny tree on the LT 3 phase 4 wire lines, the span fell down with supply and created an unsafe condition.</p>	<p>1) Necessary tree cutting should be done periodically in the close proximity.  2) If necessary such places may be provided with guarding.  3) Stay plates shall be insisted mandatorily.</p>

Description	Unsafe action	Unsafe condition	Suggestions to avoid such accidents
was a pitting on the ground for about half a foot.			
A Consumer had purchased an old building and he had a plan to demolish the old building. He has started the work of construction of a new building. Adjacent to the building there is one 11KV Line and a 3 phase 4w LT Line in a single RSJ Pole. For construction purpose they have constructed a wooden grill with a clearance of about only 1 foot to the HT (11KV) line, and carrying out the construction works. One construction worker working on that area came in to contact with the 11kv line, electrocuted fell down and died at hospital after 2 hours.	Though the person is aware of the availability of the live line passing nearby, he has proceeded with the construction work.	1) The clearance between the wooden grill and the 11kv line was too low as against the clearance specified in CEA regulations. 2) No precautionary measures have been taken.	1) Enforcement of CEA regulations on safety clearances 2) Issue of warning notice to such persons. 3) Wide publicity about such happenings to create awareness among public.
A Villager aged about 16 years old in a drizzling evening touched the GI wire fencing got electrocuted. There was GI wire fencing with the wooden support on which a 40 watts tube light was fitted and the supply to the tube light was extended by using a number of bit wires jointed together with installation and also due to the drizzling there was a leakage on the fencing. At that time, he had touched the fencing, was electrocuted, and fell down. The neighbour has contacted the Electricity Board to switch off the supply. The foreman on duty and the wireman rushed to the spot after disconnecting the supply by opening the concerned Distribution Transformer. But before that, Thiru Jayakumar was taken to the hospital by his father and at hospital it was informed that Thiru Jayakumar expired before 2 hours	1) During the drizzling time, he made an attempt with the GI wire fencing.	1) Leakage on the wiring through the GI fencing due to non standard wiring.	1) Enforcement of CEA regulations on safety pertaining to provision of Earth leakage protective device. 2) While extending supply to other places the wiring should be as per norms with ISI marked materials. 3) Public awareness should be created not to use non standard materials, non standard wiring, so many joints etc.
In one village, the president of the village Panchayat had entrusted the work of repairing of street light and bring them in to burning condition to 3 persons and they were not having no previous experience in doing such works. When, the 3 persons are about to start the works, The villagers told them to contact the EB office to switch off the supply for safety. But those persons have not put their words in ears. They reluctantly started the work, without any	1) Even though the villagers have told to switch off supply, he reluctantly attempted the work. (I know all attitude) 2) He has not used any of the safety appliances such as safety waist belt rope,	1) There was supply in the line at which the person is about to work.	1) The work of changing the street lights due to be done under the supervision of departmental person only. 2) The supply should be switched off by contacting the local EB authorities programmed well in

Description	Unsafe action	Unsafe condition	Suggestions to avoid such accidents
<p>safety appliances such as safety waist belt rope, Rubber gloves, Step wood for attending works. One person had climbed at one location, changed the street light successfully. Then the climbed on the second pole and attempted to remove the existing fitting, but he fell down due to electric shock. Before arranging a vehicle for transport to hospital, he died at the spot.</p>	<p>Rubber gloves etc.</p>		<p>advance so as to avoid dislocation of other works and to minimize the interruption time also. 3)Public also should be made aware of the consequences of such action.</p>
<p>There was a project on watering the rural areas under execution. For that a lot of pipes are to be buried after digging suitable long pits. The authorities of the project have engaged two Nos. cranes for excavation of pipe route and for insertion of pipes. The excavated pit dimensions are 8 feet depth and 6 feet width for a distance of more than 10 kms, and the pipes to be inserted are 1000 x 900 x 5000 mm.</p> <p>One location of pipe lying was near the 11 KV HT line. The crane operator and the contractors have decided to execute the works without the presence of the concerned departmental authorities, by whom these works were executed. They have not made any requests or arrangements to switch off supply during their work.</p> <p>During the process the crane accidentally made in contact with the 11 KV line, under which the excavation process was going on. One person aged 40, was holding the chair of which one end was tied with the pipe on the ground and another end to the crane arm which was in contact with the 11 KV line. So immediately he was electrocuted and died at the spot.</p>	<p>1) Without switching off the supply they have attempted to proceed. 2) There is no supervision at all. 3) They have not informed about the work to the concerned EB officials.</p>	<p>1) Working under a live line is unsafe.</p>	<p>1) The concerned authorities may be informed about the availability of supply and they should be insisted to execute the work only in the presence of a competent person to supervise it. 2) Apart from crane operator one person should be engaged by the contractor to watch the movement of the crane and for the safety in all respects.</p>
<p>On a particular day the live conductor from Y phase of a 11 KV feeder mainline snapped due to bursting of one 11 KV pin insulator. A squirrel shorted the line to earth and hence the bursting of Insulator. One side of the conductor so snapped fell down at a hard rocky place and another end on the grown Tapioca vegetation. At that time One lady and five others</p>	<p>1) The first person had touched the snapped conductor. 2) On seeing the first person got fired, the second person due to</p>	<p>1)Unearthed snapped live conductor caused the unsafe condition.</p>	<p>1) Public may be educated how to act whenever such incidents occur, through slides in cinema theaters, local cable TVs and posters.</p>

Description	Unsafe action	Unsafe condition	Suggestions to avoid such accidents
<p>were going on that way where the snapped end of the 11 KV line hanging. One of the lady among 5 who was going first got touch with the hanging line and her body got fired and also the standing crops in the farm field. Immediately the second person rushed to lift the first person under fire. But the lady pulled the second person, from touching the person who is under fire. She persuaded others also not to get in touch with the snapped wire, in the mean time, the owner of the farm rushed to the spot, assuming that the fire in due to his enemies and attempted to go inside the field. That lady stopped him also from not entering into his field. The owner of the field went to the substation on his 2 wheeler and informed them about the incident. The supply was disconnected by the SS operator. The lady who touched the line died with burn injuries and body in a charred condition. The timely wise action of the lady is appreciable and she saved 5 lives.</p>	<p>nervousness and in a thought to save her life but without realizing the situation attempted to touch the burning woman. 3)The owner of the land where the incident occurred also made an attempted to step in to the field without knowing what was happened. This is also an unsafe action.</p>		<p>2) Even if it is warranted, then the person who is under crisis may be touched through a well-insulated medium like, rubber, wood, cloth, gunny bags etc, but with utmost care. 3) During the time of winds, the SS operators may be asked to use the crack switch for equality of loads, there by snapping in the mainline that too near to the SS may be detected.</p>
<p>A hard ware mart is situated on a roadside and they are dealing with trading of Iron rods, pipes etc. They have stocked the materials in the upstairs. There was one 22 KV Line on the side of the shop. On a day a servant aged 40 years, working in the hard ware mart was asked to bring a pipe of 10 feet length of from the stock room for sales. He has taken the 10 feet pipe and attempted to bring down through stairs. On such time accidentally the pipe had touched the HT Line and got electrocuted, his body was hanging on the parapet wall in a burnt condition and Iron pipe pasted with his body.</p>	<p>While bringing down the pipe he has not taken any cautions steps so as to avoid touching of pipe on HT Line</p>	<p>In adequate clearance between the building and the HT Line</p>	<p>1) Enforcement of CEA regulations on clearances 2) There sort of accidents should be brought to the knowledge of the public to create a sense of awareness.</p>
<p>There was harvesting in the paddy field of a village. After harvesting was over, the "hay" was dumped on a lorry to a height more than that of normal. The lorry started and was going through a street. On the en route there was one LT Line crossing the street. The driver of the lorry asked a person to lift the LT Line by using a stick from the "hay" dumped on the lorry. He also came to the back portion of the</p>	<p>1)The person's attempt to lift the LT Line. 2) The reluctant action of the driver even though the 2 persons asked to stop the lorry.</p>	<p>1) Dumping of hay to over height. 2) LT Line crossing without guarding with low clearance.</p>	<p>1) Enforcement of CEA regulations regarding clearances on streets. 2) Wide publicity should be made to create awareness among people not to overload on vehicles and</p>



Description	Unsafe action	Unsafe condition	Suggestions to avoid such accidents
<p>lorry. Another 2 persons are watching whether the line is touching the “hay dump”, from either side of the road. When the clearance between the LT Line and the “hay dump” became too low, the 2 persons standing on the road shouted to stop the lorry. But the driver was very reluctant and he moved the lorry. In the mean time the man who was on the top of the lorry was not able to lift the LT line, but contacted the LT Line, due to movement of the lorry and electrocuted. He was thrown away from the lorry with burn injuries and died at the spot itself.</p>			<p>also not to travel on the loaded articles of the vehicles.</p>
<p>During on rainy season one phase conductor of a 4 wire line snapped and fell on the thatched roof of a house. At that time no body was inside. During night, the resident of the house came and saw the snapped wire. In order to enter in to the house, that person tried to lift the snapped live wire with his left hand, got electrocuted and died at the spot. It is understand that the snapping is due to giving service connection directly from the line without making any “PA” jumpers. During rainy season the service connection wires jointed on the line directly gave to arcing locally. If there was a “PA” jumper, this would not have occurred</p>	<p>The action of the person touching the snapped conductor with bare hands</p>	<p>1)Service connection wires were not given through jumpers and there is every possibility of snapping of conduct due to local arcing.</p>	<p>1) Whenever service connection is given, then it should be given only through jumpers. 2) Public should be educated not to touch any wire fallen and they should inform to the EB office.</p>
<p>A person was having a hut service in his village. He was engaged in construction of a “Pandal” in front of his hut. On digging a pit with a “crow bar”, he raised the crow bar to a height above his head. The service connection wire leading to his service was in a damaged condition (insulation peeled out) and with low sag and almost hanging. Due to the above, the crow bar touched the damaged service wire he electrocuted and died on the spot.</p>	<p>Working under any line is unsafe.</p>	<p>) The service connection wire was damaged. 2) The vertical clearance of service wire was too low.</p>	<p>1) The service wires should be replaced by healthy ones at periodical intervals. 2) The low sag to be set right.(GI bearer wires shall be insisted and reel insulators shall be used. 3) Public should be informed to not work under any line.</p>

Description	Unsafe action	Unsafe condition	Suggestions to avoid such accidents
<p>A Consumer was having a small fishery in his land near by the sea shore. For that fishery, he was having an electric service connection in side a small thatched shed which was poorly illuminated. The switches are also nearby the service connection point near the meter. To switch "ON" the pump motor for watering the fish farm, he went inside the shed. During the time, it was raining, and he was wet as he came through the rain. When he touched the switch of the motor he was electrocuted, due to wet condition on the floor, (as it is in the seashore) and body. He fell down on falling down, he shouted and his friend touched him on an attempt to save him. He was also thrown away .He died and his friend recovered with small injuries on his hand.</p>	<p>1)His attempt to switch "ON" the motor in wet condition without any insulation on the foot. (Neither foot wear nor rubber mat 2) The attempt of his friend to save him from the crisis without any precautionary action.</p>	<p>As the weather is rainy, and he is also wet due to rain. The service connection point became unsafe. (As the area is on the sea shore)</p>	<p>1) Provision of Earth Leakage Circuit Breakers. (ELCB). 2) Provision of rubber mat or plastic or wooden insulated portion under the switch board place. 3) Awareness among public not to operate electric without insulation on the foot.</p>
<p>A farmer aged 55 years was walking for his paddy field in the early hours say about 5.00 AM. On the way there was a snapped conductor from the 3 phase 4 wire ACSR line, leading to an agriculture service. When he tried to cross the snapped wire, accidentally he got in touch with the live wire and electrocuted. The snapping of conductor was due to broken LT rusted strap set on that cut point of the LT line. The Insulator was also damaged and the line was hanging at a distance of 2 feet from the ground due to the grip with the jumper. Hence not grounded.</p>	<p>His attempt to cross the live wire which was hanging.</p>	<p>Conductor snapping due to failure of rusted LT strap sets of 2 mm thickness and broken insulator.</p>	<p>1) During Line maintenance the rusted LT strap sets may be replaced by good ones that too with 3 mm thickness. 2) Avoiding of GI wires in place of LT strap sets due to non availability of strap sets at that time. 3) Consumer Education not to touch the live snapped wire.</p>
<p>This case is just like the previous case, but the conductor snapping is due to the failure of GI wire used in place of LT strap sets. This also caused a fatal accident to another person.</p>		<p>Non provision of Strap sets for Shackle insulators</p>	<p>1) Due to non-availability of LT strap sets the practice of using GI wires is increasing. Hence it should be insisted not to use GI wires instead of LT strap sets. 2) In circle level, the small, but basic materials like strap sets, kept available at all time, for replacement of</p>

Description	Unsafe action	Unsafe condition	Suggestions to avoid such accidents
			<p>rusted GT LT straps and to replace the GI wires already used. Our standards should not be compromised at any time due to want of / non availability of required materials.</p>
<p>There was a work of tree cutting on a 3 phase 5 wire line, which goes through a street. The respective Distribution Transformer was switched “OFF” properly &amp; earth rods were provided. Then only, the tree cutting works were carried out. After completion of the tree cutting works, and after confirming that there are no tree branches on the line, the concerned wireman has informed the residents of the street that he is going to switch “ON” the Distribution transformer, Do not proceed with the tree cutting work, and then he charged the Distribution Transformer.</p> <p>One villager found that one branch of already cut down tree was touching with the above line. He tried to remove the branch but the branch twisted the “R” phase of the line &amp; the street light line, made puncture of the street light wire that wire got in touch with the steel tubular pole. The tubular pole was very near to a pond where one lady aged about 40 years taking bath. Due to the touching of R phase line---- street light wire – steel tubular pole – pond, the lady was electrocuted, with loss of life.</p>	<p>The action of the villager in attempting to remove the cut down branch of the tree which was touching line after energisation of the line.</p>	<p>The cut down branches of the trees have not been isolated</p>	<p>Whenever such sort of works is carried out, the cut down branches of the tree are to be cleared away from the reach of the live line.</p>
<p>One municipal tipper lorry collected the wastes from the streets and disposed in the compost well in a remote area. One such occasion was so happened that the lorry while down loading the waste by use of hydraulic lever of the tipper, the waste banana tree rose up with the 11 KV HT line. At that time a scavenger of that municipality, touching the tipper portion was electrocuted and died. The driver of the vehicle also was affected by burn injuries and he escaped as he jumped away from the lorry.</p>	<p>Without watching the movement of the tipper the driver has operated the hydraulic lever is unsafe action. The action of touching of the moving tipper by the scavenger is also an unsafe action.</p>	<p>Depositing waste under the HT line created the unsafe condition.</p>	<p>1) Concerned Municipal authorities may be cautioned not to dispose the waste under live lines by use of such tippers, crane etc. 2) On receipt of request from the concerned authorities for whom work to</p>

Description	Unsafe action	Unsafe condition	Suggestions to avoid such accidents
			be carried out near the live lines, necessary arrangements may be made to "Switch off" the supply until the completion of work.
<p>A housewife aged 48 washed the clothes and hangs the above wet clothes to day in a steel wire which was tied up to a GI pipe. The electric connection pipe was also tied with a steel wire to this pipe. On a rainy day, due to wind, the service connection pipe was broken and was a leakage on service pipe----- steel wire----- GI pipe----- support of GI wire for cloth hanging purposes. When the lady made touch with the GI wire she was electrocuted and her life ended in fatal.</p>	<p>Her attempt to touch with wet medium to GI wire is unsafe action.</p>	<p>Leakage on the Service connection pipe---GI wire---GI pipe due to wet condition</p>	<ol style="list-style-type: none"> <li>1) Providing ELCB in services and effective earthing of services.</li> <li>2) Providing quality GI pipe for service connection.</li> <li>3) Not to connect anything with the SC pipe directly or indirectly.</li> <li>4) Awareness among public should be created not to tie drying wires with any Electrical equipments / supports.</li> </ol>
<p>There was a public hand pump in a village for pumping water from a bore well installed at middle and underneath the electric line of HT / LT spans of about 40 meters. HT line is on the top and below it. There was an LT single phase 2 wire line. Near by the line there was a coconut tree. Due to growth of the tree branches, one of the branches got in touch with the LT phase &amp; neutral, hence the conductor snapped and fallen down on the metal part of the hand pump. A girl aged 15 years when touched the hand pump got electrocuted and life ends in fatal.</p>	<p>The action of the girl making contact with the hand pump.</p>	<ol style="list-style-type: none"> <li>1) Snapped conductor fallen down on the metal part of the hand pump, and supply available on the hand pump.</li> <li>2) The branches of the coconut tree touching the live line.</li> </ol>	<p>Tree cutting should be made at periodical intervals.</p>

## Annexure - I

### FORM FOR APPLICATION OF LINE CLEAR PERMIT

LC Application No.	Date
1 Name	
2 Designation	
3 Employee No.	
4 Mobile No.	
5 Section	
6 Equipment / Feeder / Line Section on which LC is required	
7 Mention the Exact location where the work is to be carried out	
8 Date and Time of LC required	
9 Approximate duration of LC required	
10 Nature of work	
11 How many persons to be engaged in the work	
12 Any other feeder / Line crossing that location	
13 Signature	
14 Recommendation of the Officer with Name & Designation	

## OFFICE USE

(To be printed on back side of the LC application)

1	LCP No. / Date	
2	Time	
3	Random No / OTP	
4	LC issued by(Name & Designation)	
5	LCP returned / Time / Date	
6	LCP cancelled by(Name & Designation)	
7	Feeder / Equipment Normalised at Time / Date	
8	Observations after normalization if any	
9	Remarks if any	
10	Signature, Name, Designation of the Operator on duty with date	

Line clear permit shall be issued to the authorized person only, on receipt of an application in the above prescribed format.

In case of any emergency LC, where the application form may be filled in and the signature of the recommending Officer could not be obtained, then in such cases a random No. / OTP may be sent to the mobile of the Officer who is authorizing the applicant. Then the OTP has to be forwarded to the applicant. On production of Random No / OTP to the SS Operator, the LC may be obtained. The same shall be recorded on the Log book.

The application for LCP shall be recorded in the Office and kept in safe custody. The same shall be reviewed by the Officer in charge then and there before the next day.

**Annexure – II**

**Letter to Consumer to provide adequate clearance**

**TANGEDCO Ltd**

From

The Competent authority,

TANGEDCO

To

The applicant with address

Sir,

Sub:- Elec- inadequate clearance as per CEA regulation-request for action for making sufficient clearance

Ref:- your application dated (if applicable)

The building / premises under Door No. (Complete address) has been inspected by the undersigned on----- . During such inspection the following are noticed.

- The Vertical / Horizontal clearance between the HT / LT line as per CEA regulations shall be-----metres.
- But the actual clearance is----- metres(Please Quote the regulation No & statutory clearance)

Hence you are requested to comply with the safe clearance by making an application in the Office of the undersigned for making necessary deviation of the Lines to a safe clearance limit and you shall require to pay the amount on receipt of communication from the undersigned.

(Upon satisfactory clearances are met, then only your application for service connection will be considered) (if applicable)

Please note that If by the inadequate statutory clearance, (un safe condition)as said above, any untoward incident happens, TANGEDCO will not be responsible for such happenings and you will be solely responsible for such occurrences if any.

Sd/-date

Authorised Officer/ TANGEDCO

Copy to

**Annexure – III**  
**Accident Reporting Forms**

**PRELIMINARY REPORT**  
**FORM A**  
**FORM FOR REPORTING ELECTRICAL ACCIDENTS**

1. Date and time of accident.
2. Place of accident (Village/Town, Tensil/Thana. District and State).
3. System and voltage of supply (Whether Extra High Voltage (EHV)/High Voltage (HV) / Low Voltage (LV) Line, sub-station/generation Station/consumer's Installations/service lines/other installations).
4. Designation of the Officer-in-charge of the generating company/Licensee in whose jurisdiction the accident occurred.
5. Name of the owner/user of energy in whose premises the accident occurred.
6. Details of victim (s)

**(a) Human**

Sl.No	Name	Father's Name	Sex of Victim	Full Postal Address	Approximate Age	Fatal/ Non Fatal
1	2	3	4	5	6	7

**(b) Animal**

Sl.No	Description of Animal(s)	Number (s)	Name (s) of Owner(s)	Address (a) of owner (s)	Fatal Non-Fatal
1	2	3	4	5	6

**7. In case the victim(s) is / are employee(s) of supplier:-**

(a) designation of such person (s)

(b) brief description of the job undertaken, if any:



(c) Whether such person / persons was / were allowed to work on the job.

**8. In case the victim (s) is / are employee (s) of a licensed contractor:-**

(a) did the victim (s) possess any electric workmen's permit (s), Supervisor's certificated of competency?

If yes, give number and date of issue and the name of issuing authority:

(b) Name and designation of the person who assigned the duties of the victim (s).

9. In case of accident in the system of the generating company/licensee, was the permit to work (PTW) taken?

10. (a) Describe fully the nature and extent of injuries, e.g., fatal/disablement (Permanent or temporary) of any portion of the body or burns or other injuries.

(b) In case of fatal accident, was the postmortem performed?

11. Detailed causes leading to the accident.

(To be given in a separate sheet annexed to this form)

12. Action taken regarding first aid, medical attendance etc., immediately after the occurrence of the accident (give details).

13. Whether the District Magistrate and Police Station concerned have been informed of the accident (if so, give details).

14. Steps taken to preserve the evidence in connection with the accident to extent possible.

15. Name and designation (s) of the person (s) assisting, supervising the person (s) killed or injured.

16. What safety equipments were given to or used by the person (s) who met with this accident (e.g. rubber gloves, rubber mats, safety belts and ladders etc)

17. Whether isolating switches and other sectionalizing devices were employed to deaden the sections for working on the same? Whether working section was earthed at the site of work?

18. Whether the work on the live lines was undertaken by authorized person(s)? If so, the name and the designation of such person(s) may be given.

19. Whether artificial resuscitation treatment was given to the person (s) who met with the electric accident? If yes, how long was It continued before its abandonment?

20. Names and designations of persons present at, and witnessed, the accident.

21. Any other information / remarks

Signature

Name

Designation

Person reporting

Place:

Time:

Date:

**FORM FOR REPORTING OF ACCIDENT  
 DETAILED REPORT  
 INVESTIGATION REPORT - PART - A - TECHNICAL**

**I. Brief Particulars of Accident Investigated**

- 1. Date of Accident :
- 2. Place of Accident :
- 3. Classification Departmental/Non - Departmental/  
 Fatal/ Non - Fatal/Electrical/Mechanical :
- 4. Name of the Injured :
- 5. Sex and Age :
- 6. Date of Investigation :
- 7. Name Designation and Address of the Party  
 who reported the accident :
- 8. Residence of the causality :
- 9. Name and designation of the Investigation officer :

**II) Details of Investigation made**

- a. Name of witnesses examined Statements of  
 witness recorded (copies to be enclosed) :
- b. whether statements obtained :
  - Of the injured, if non - fatal :
  - Of the foreman / LT Supervisor :
  - Of the Manager / or employed if the injured  
 met with the accident in a factor :
  - Of the Medical Officer who attended the  
 injured Police Report. :
- c) Exhibits examined and sites inspected by the  
 Investigating Officer :
- d) A neat sketch showing the site of accident:

**III) Descriptive Report of the Accident :**

IV) Analysis of the accident and findings of the investigation officer :

a. Non - Departmental (Electrical)

Whether mental Unbalance or attempt Suicide :

b. Departmental (Electrical)

Whether due to Unsage act or failure to use safety equipment LC precautions etc., Use of Safety

Appliance :

1. Whether belt rope used:
2. Whether rubber gloves / gauntlets used:
3. Whether LC availed:
4. Whether lines/equipments discharged/and earthed:

c. Departmental (Mechanical) falls generally under the following:

Falls from pole, during climbing or during work.

Handling of Materials.

Note: The Investigating officer will try to find the root cause of the accident and make recommendations on the preventive measures to be taken to prevent recurrence. The responsibility for the occurrence of the accident and action taken against the erring staff.

## Investigation Report Part - B - Administrative

### Additional particulars for compensation claims.

#### a. Non - Departmental

1. Name of injured :
2. Full Address :
3. Occupation :
4. Approximate Annual Income :
5. Nature of Injury : Fatal or Non - Fatal:  
If Non - Fatal - Nature and extent of disability for  
which compensation claims is preferred :
6. Name and full address and relationship to the  
injured of the claimants :
7. If the compensation claim is in respect of any  
Property, details of property and their value :

#### b) Departmental :

1. Name of injured :
2. Designation :
3. Service roll / check No :
4. Section: Sub-Division: Division:
5. Whether accident occurred out of or in the course of  
employment :
6. Date from which he is in service :
- 7.a) Particulars of pay for one year immediately  
Proceedings the date of accident for fixing  
compensation amount :
- b) Whether wages were allowed for the date of  
accident :
8. Date of accident:  
If fatal date of death :  
If Non- fatal :

- Date from which he was disabled :
  - Date of admission to the Hospital :
  - Date of discharge from the Hospital :
  - Date of fitness certificate :
  - Date of rejoining duty :
  - Name and Designation of Medical Officer :
9. In case of Permanent disability :
- Nature of Injury :
  - Part affected :
  - Percentage loss of earning capacity :
  - Date of issue of medical certificate :
  - Name and Designation of Medical Officer :
10. In case of fatal accident:
- Name and full address of heir/s :
11. Whether the accident was due to negligence of the workmen. If so action taken against the workmen may be briefly stated. :

Signature of Investigation Officer,

N.B. Part 'B' report may be sent separately.

## INVESTIGATION REPORT FOR FATAL ACCIDENT TO HUMAN BEINGS

1.	Name of the circle	
2.	Name of the Division and sub division	
3.	Name of the section	
4.	Location of Accident	
5.	Date and Time of Accident	
6.	Name of Person (S)	
7.	Whether Departmental or Non-departmental person (S) if departmental person please specify the designation	
8.	Nature of Accident whether Mechanical / Electrical / Line.	
9.	If Electrical please specify voltage class of the Equipments / Line	
10.	Details such as whether the accident has occurred due to defective installation of consumer in the consumer premises	
11.	Whether the Board is responsible to pay compensation and date	
12.	Whether Police complaint was lodged and crime No. & date	
13.	Brief details of accident	
14.	Cause for the accident	
15.	Date of inspection of accident spot by the Superintending Engineer	
16.	Suggestions of the Superintending Engineer for averting similar accidents	
17.	Details of preventive / punitive action Suggested / taken to prevent recurrence	

**SUPERINTENDING ENGINEER**

## Annexure – IV

### Safety / Audit

#### FIELD JOB AUDIT Report

Report No:

Date:

Location: \_\_\_\_\_

Month/Year: \_\_\_\_\_

1. Name of Supervisor on site \_\_\_\_\_

2. Nature of Job:

3. LCP No.: \_\_\_\_\_ Date: \_\_\_\_\_ Time: \_\_\_\_\_

4. Name & Designation of work men

1.

2.

3.

4.

5.

5. Any unsafe conditions noticed:

Sl. No	Unsafe condition	Remarks
1	No message in job allocation	
2	No proper LCP obtained	
3	No proper Supervision at Site	
4	Not using safety equipment like helmet / hand gloves / fuse puller / safety shoes/ Belt rope	
5	Using improper tools	
6	Shortage of tools	
7	No danger board on switchgear control	



8	No Safety zone is created	
9	Equipment / Line not properly / not earthed	
10	Bad site conditions	
11	Condition of PPEs	

Additional remarks if any:

Signature of Committee members