

Drafting: Orthographic and Isometric Drawings

Description

Students will learn to develop and interpret plumbing drawings typically found in construction. There are two parts to this lesson:

- Part 1: Orthographic drawings
- Part 2: Isometric drawings

Lesson Outcomes

The student will be able to:

- Create orthographic drawings of objects, including a piping system
- Create isometric drawings of objects, including a piping system

Assumptions

The teacher has a basic understanding of drafting. This document seeks to teach the student about practices used in the plumbing trade. It is assumed the teacher has a basic understanding of the development of orthographic projections and isometric drawings.

Terminology

Fitting: an object used to connect one or more pieces of piping material to another.

Isometric: a method of representing three-dimensional objects on a flat surface by means of a drawing that shows three planes of the object.

Orthographic: a method for representing a three-dimensional object by means of several views from various planes.

Estimated Time

1–3 hours

Recommended Number of Students

Individual activity

Facilities

Classroom activity



Tools

- Pencil, ruler, eraser
- Tee square (Figure 1)
- 30/60/90 triangle



Figure 1—A tee square is used to align drafting drawings to a square surface (such as a table).

Materials

- Unlined paper
- Isometric paper (Figure 2)

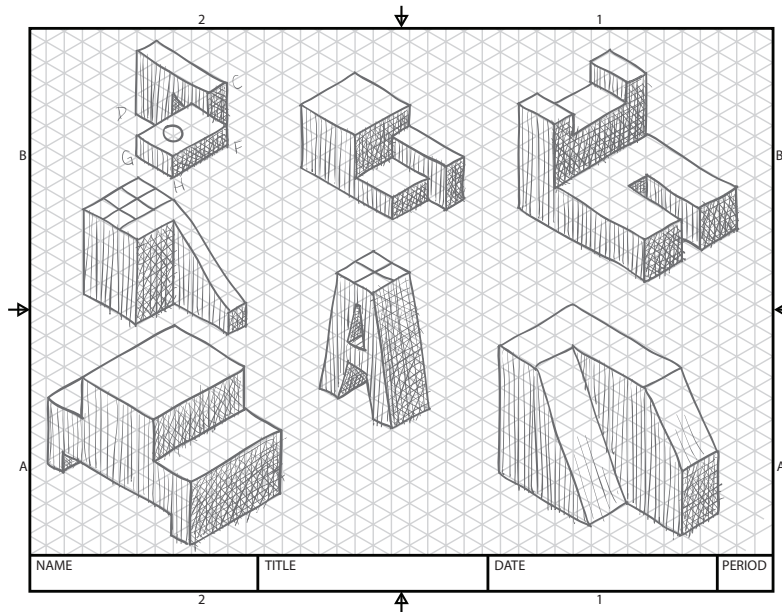

Figure 2—Isometric paper is helpful for novice students to design isometric drawings.

Resources

Brief overview of freehand isometrics

http://www.youtube.com/watch?v=KN7281MUp_U

Fun video showing the development of an isometric drawing of a Rubik's cube

<http://www.youtube.com/watch?v=BPDpsaX-Usw>

Activity Background

Communication between architects, homeowners, tradespeople, and inspectors plays an important role in the development of any project. While this could take place through extended conversations, the most efficient way to ensure success is through the use of drawings and diagrams. A plumber should be competent in creating and interpreting drawings. Time and materials can be wasted if a project is not planned well.

Part 1: Orthographic Drawings

Orthographic drawings are projections from a single angle. Most objects can be fully represented showing a front view, side view, and top (or plan) view.

The biggest limitation of orthographic drawings is they represent a single perspective that may not show details hidden from view. For this reason, several views may have to be shown to indicate all details. Most commonly, front views and top views are shown.

-

Activity 1: Create Orthographic Projections

Have students create an orthographic representation of an object. Large, box-like objects without a lot of detail tend to be good starting points.

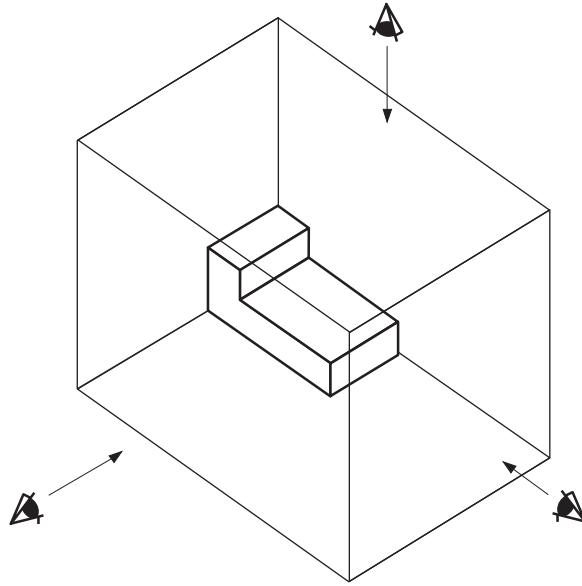

Figure 3—Imagine an object floating inside a glass box.

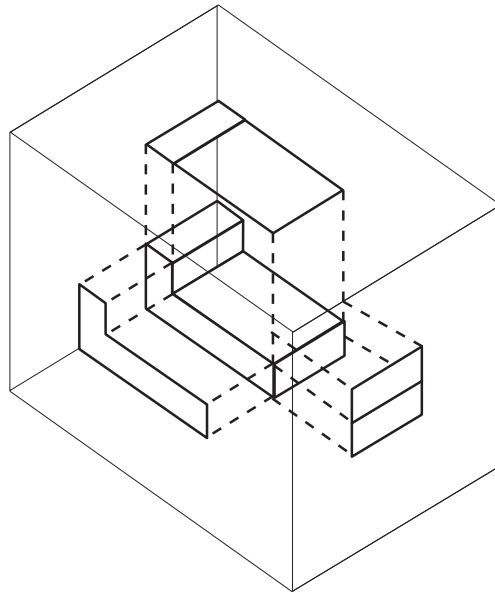

Figure 4—Each side of the glass box shows only one plane of the object, and all lines are straight and parallel.

Labeling views is a helpful method for students to make the connection between an object and its orthographic projection (Figures 5 and 6).

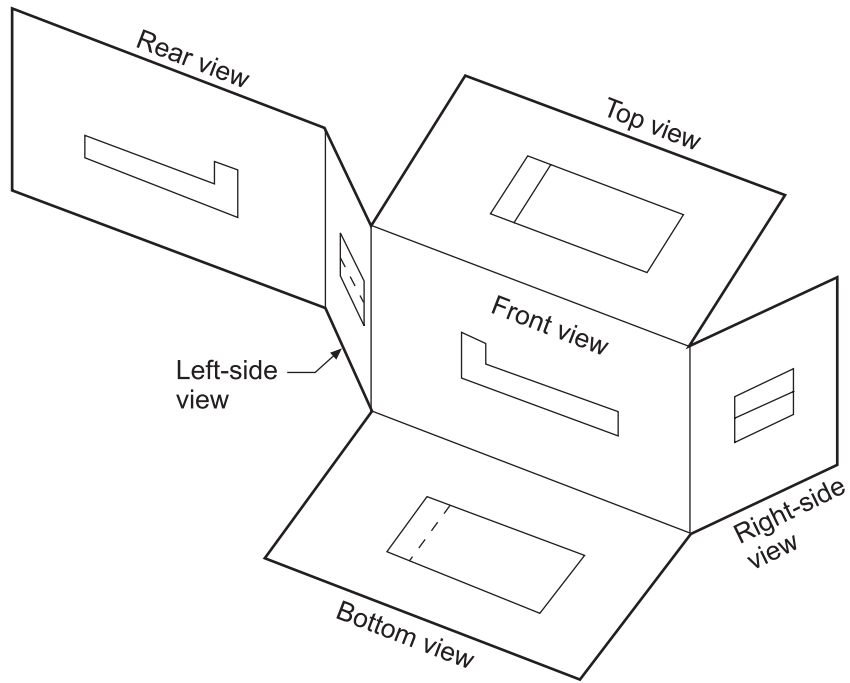

Figure 5—Views in an orthographic drawing

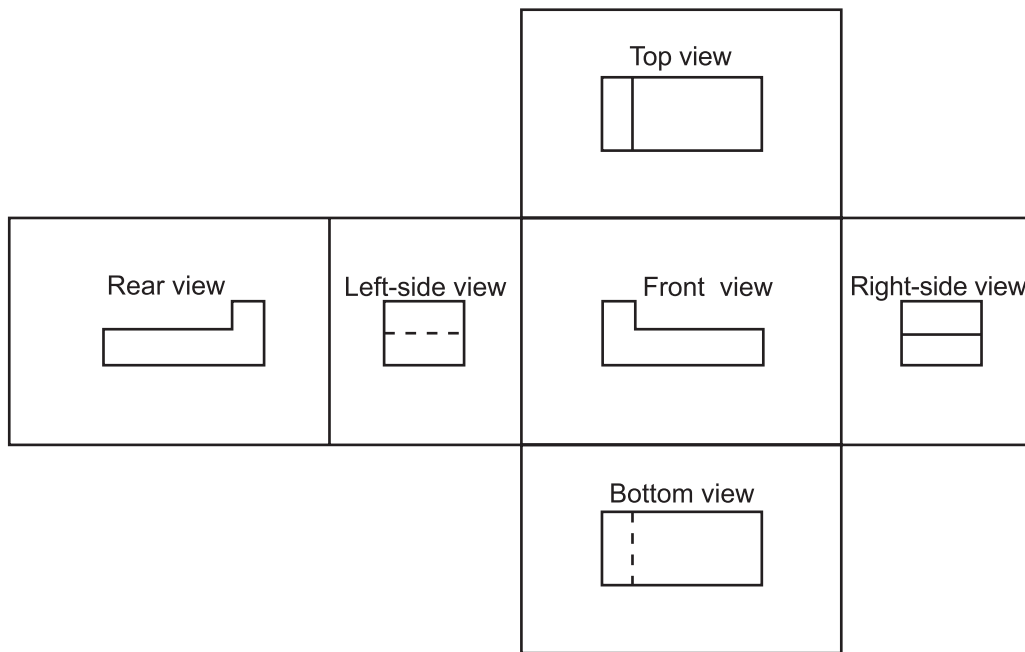

Figure 6—Drawing with the glass box flattened out

Activity 2: Create Plumbing Orthographic Projections

The teacher should create a piping system large enough so that it can be displayed at the front of the class and students can draw an orthographic of the object. As the plumbing orthographic samples below display, the object could be drawn from different perspectives.

Piping systems are regularly represented by orthographic projections. Blueprints of a large project are typically top (or plan) views. This activity is designed for students to draw orthographic projections of an actual piping system. The challenge of creating piping orthographics is that symbols must be used to represent 90° elbows or tees pointing toward or away from the viewer. Figure 7 identifies the possible orthographic projection views that could be used to represent an elbow fitting.

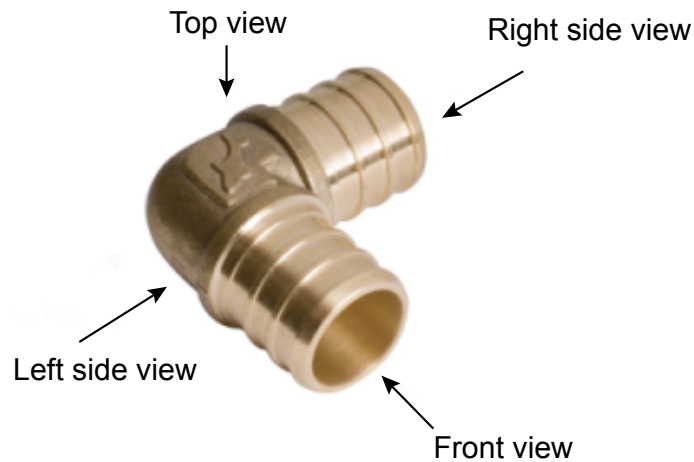

Figure 7—Elbow fitting with possible orthographic projection views labelled

For the fitting shown in Figure 7, the orthographic projection for the indicated views would be shown as in Figure 8.

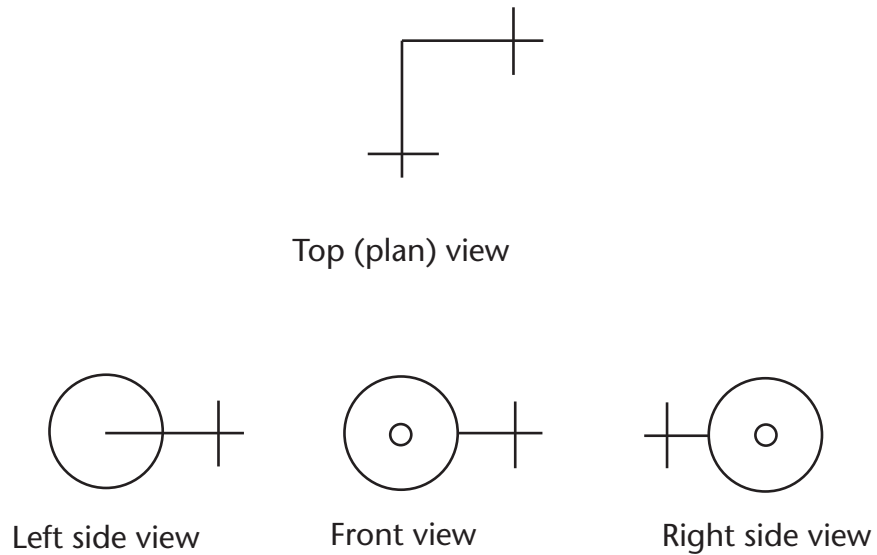

Figure 8—Orthographic projections for the elbow fitting in Figure 7.

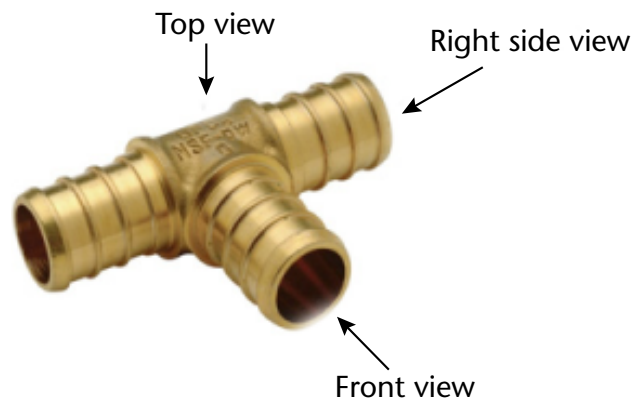

Figure 9—Tee fitting with possible orthographic projection views labelled

For the fitting shown Figure 9, the orthographic projection for the indicated views would be shown as in Figure 10.

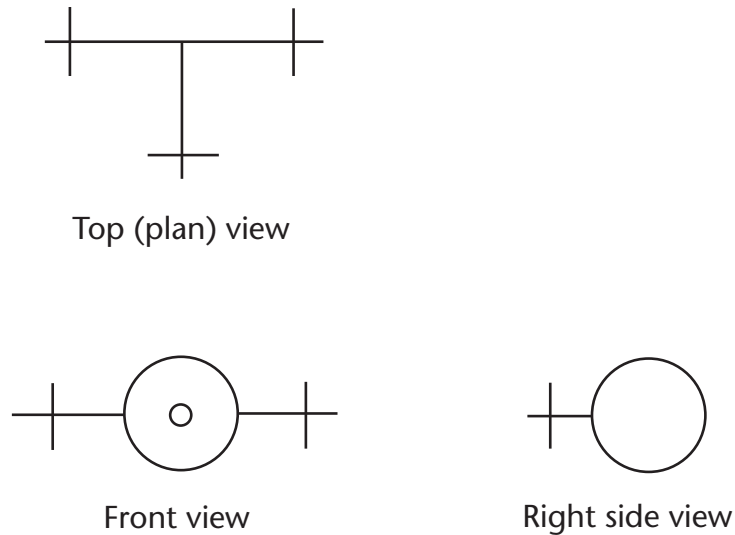

Figure 10—Orthographic projections for tee fitting in Figure 9

Figure 10 identifies the possible orthographic projection views that could be used to represent the tee fitting being referenced.

Notes

- A fitting shown pointing “outward” from the page is shown with a dot. This represents the inside of the fitting.
- A fitting shown pointing “inward” into the page is indicated with a solid line halfway through the fitting. This represents the back of a fitting.
- As the sample plumbing orthographic illustrates, the biggest drawback of orthographic projections is that fittings are often hidden from view. In other words, the fittings closest to the viewer are clearly indicated, but the details of piping “in behind” are not shown.
- The hashmarks indicate the connection to another pipe or fitting.

Figures 12–14 show samples of an orthographic projection that could be created after viewing the arrangement of piping in Figure 11. Students could be directed to draw each of the three views.



Figure 11—Tube structure for orthographic drawing activity

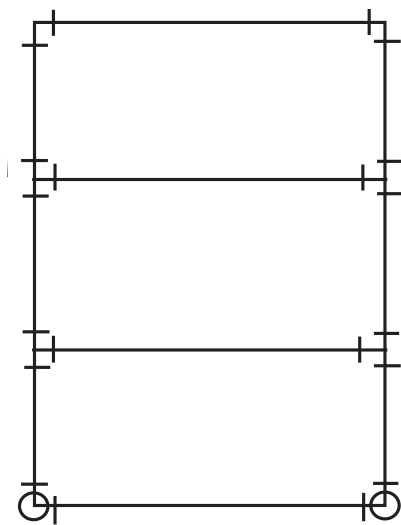

Figure 12—Front view

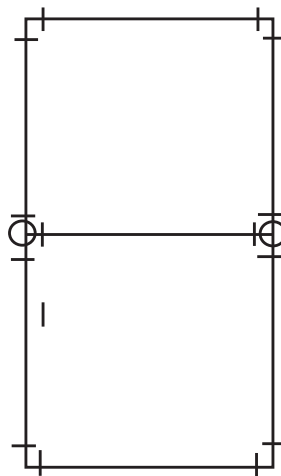

Figure 13—Plan view

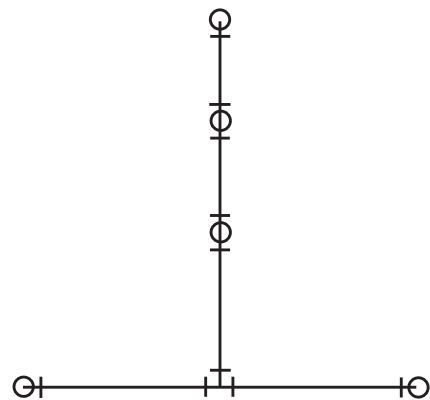

Figure 14—Right view

Part 2: Isometric Drawings

Isometric drawings are most commonly used by tradespeople to communicate a large amount of information in a single drawing. Because isometric drawings show three sides of an object, they make it easy to visualize how a finished project may look or to better understand how the pieces will fit together. As demonstrated in the development of orthographic drawings, much more detail can be conveyed in a single isometric drawing than in a series of three orthographic drawings.

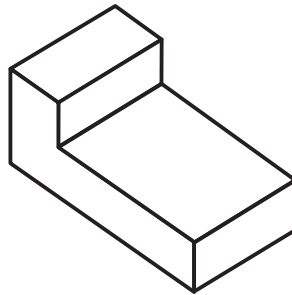

Figure 15—Isometrics show a three-dimensional object from three perspectives in a single drawing.

An isometric drawing can be identified by several factors:

- Vertical planes or edges are still drawn vertically.
- Left and right planes are drawn at an angle of 30° above horizontal.
- No horizontal lines are found on isometrics.

The strength of using isometrics in the plumbing trade is that all fittings can be shown on a single drawing, whereas an orthographic may have fittings hidden from view. This can create confusion and uncertainty in the mind of the tradesperson. It is common practice for a tradesperson to examine blueprint drawings (orthographic plan views) and create isometric sketches to clarify areas of uncertainty. This can be used to discuss issues with inspectors, supervisors, architects, or homeowners. The ability to visualize and plan a project before actually using materials is a valuable skill.

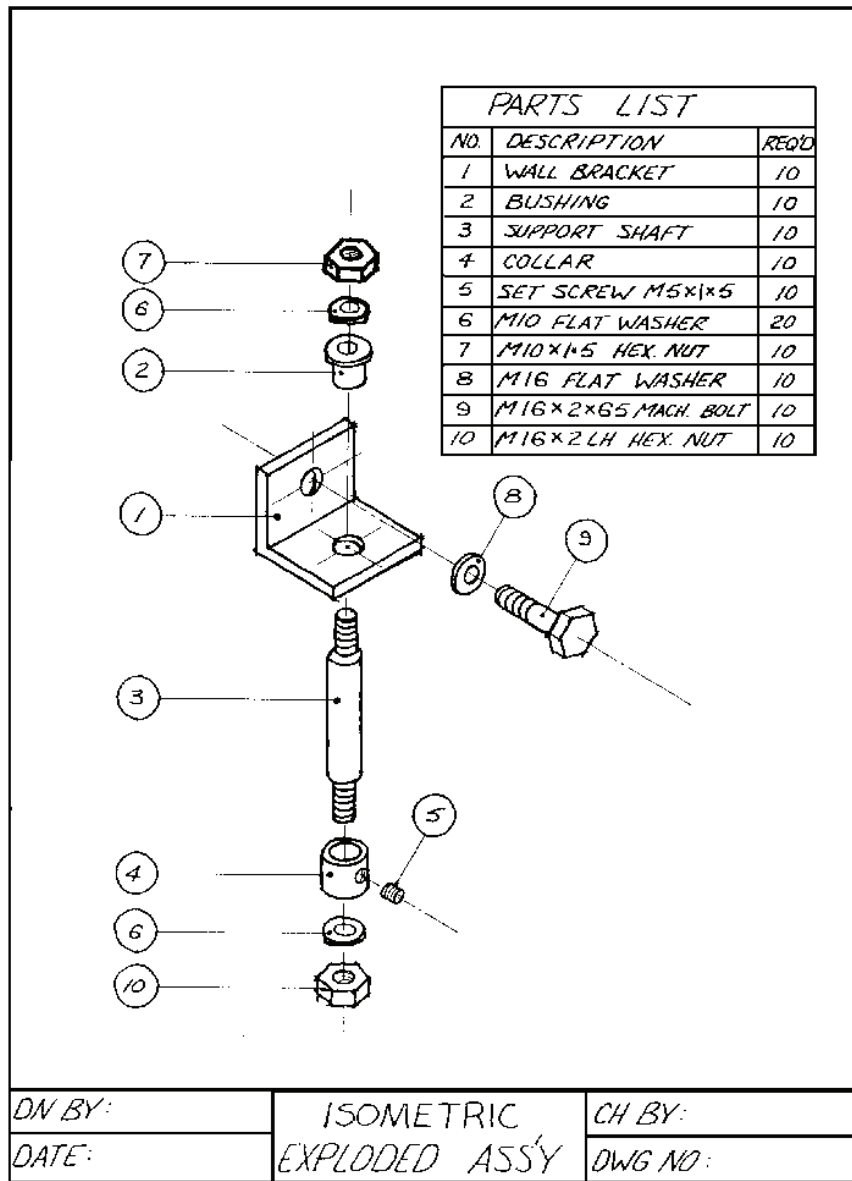

Figure 16—Assembly drawings are typically drawn in isometric form, as they can convey how parts are to be connected.

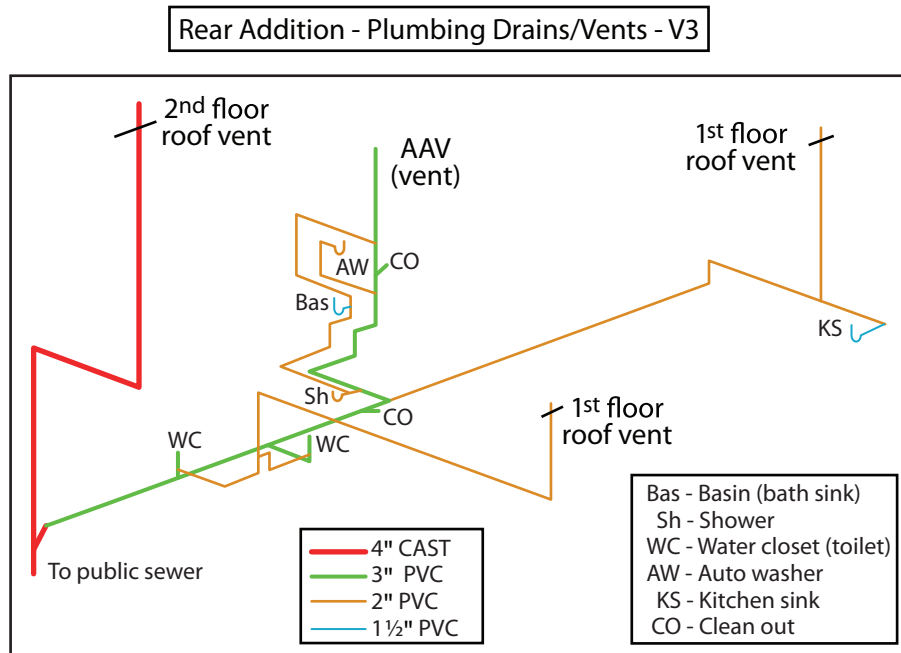

Figure 17—Isometric drawings allow a tradesperson to accurately determine how systems will be integrated and what supplies will be necessary for construction.

Activity 3: Create Isometric Drawings

Have students sketch an object using correct isometric standards. Large rectangular objects such as a television or computer are typically best for beginners. Labelling the sides of the object with a sticky note may assist novices to differentiate between the different planes. Isometric paper (includes vertical axes as well as 30° axes already laid out) is an excellent way to begin. As students begin to understand the parallel manner of the various planes, a tee square and $30/60/90$ triangle on unlined paper can be used.

Teacher Notes

- Isometric paper can be used as a tool to support the novice. It serves as a physical reminder of the 30° planes used to create depth on the flat drawing surface.
- Depending on the age and ability of the students, sketching isometrics freehand (without a straightedge) may be an objective toward which students should be working. Isometrics are commonly sketched on job sites to quickly communicate information. As students gain confidence and expertise, this skill should be developed.
- Teachers should encourage students to incorporate isometric sketching into other activities. The design of virtually any product begins with a sketch showing how the product will eventually look. The ability to communicate an idea to others without extensive conversations is an excellent means of brainstorming.

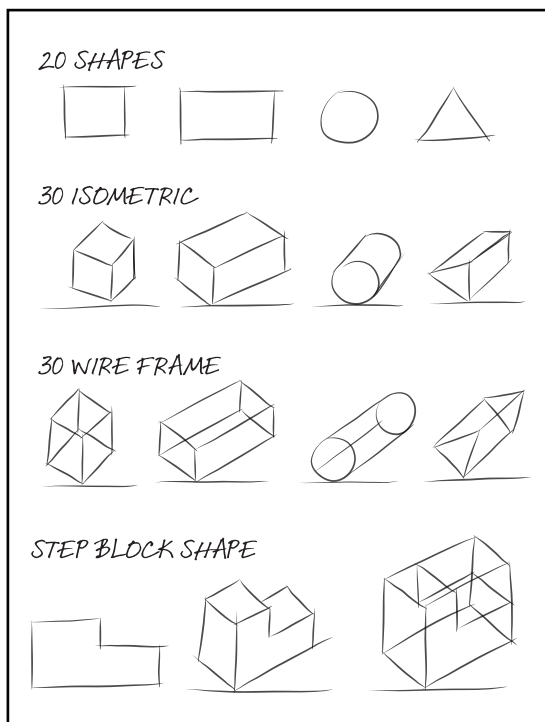

Figure 18—Basic shapes and simple ideas can be shown more realistically through the development of isometric sketches.

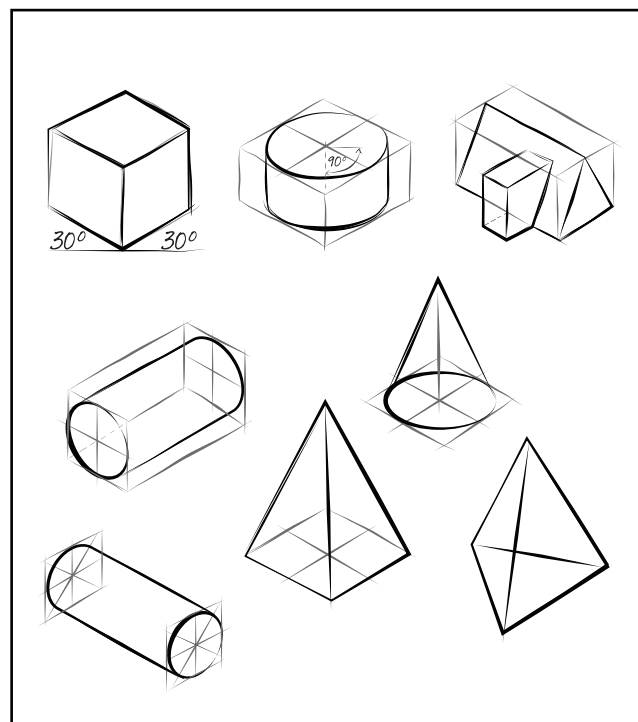

Figure 19—More complex shapes can be created by creating wire frames or boxes to which detail is added.

Activity 4: Create Piping Isometric Drawings

Have students create an isometric drawing based on an existing system of pipe. See below for sample pictures and drawings that could be created. As students gain skill, more complex systems could be shown and drawn.

Teacher Notes

- The shoulders of the fittings are drawn parallel to the opposing outlet.
- In terms of classroom management, it is likely easiest to show pictures of small systems on a projector rather than guiding students to draw isometrics in a lock-step format.

Below are sample piping arrangements and the isometrics that would represent them.

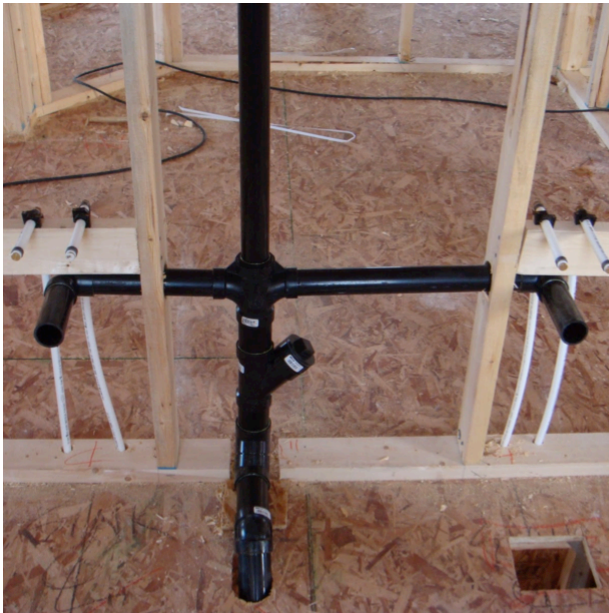

Figure 20—ABS piping installation

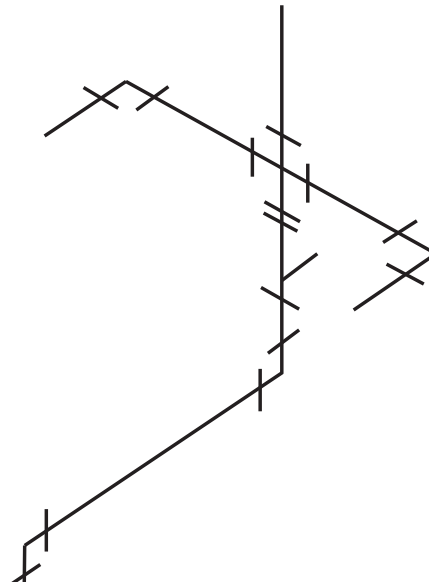

Figure 21—Isometric drawing of ABS piping installation



Figure 22—Lamp constructed from piping and bottles

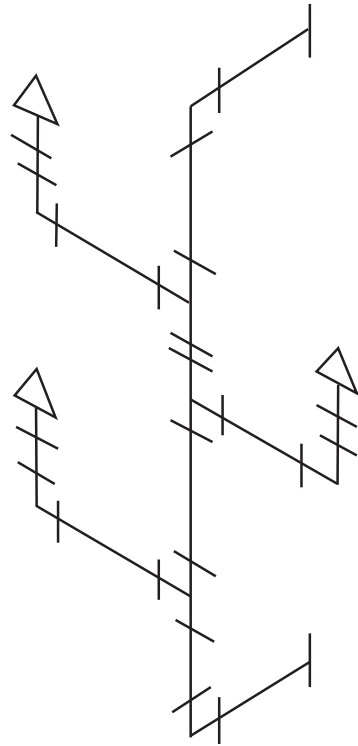

Figure 23—Isometric drawing of piping and bottle lamp. An open-headed arrow is used to represent a light bulb.



Figure 24—Drainage and water lines

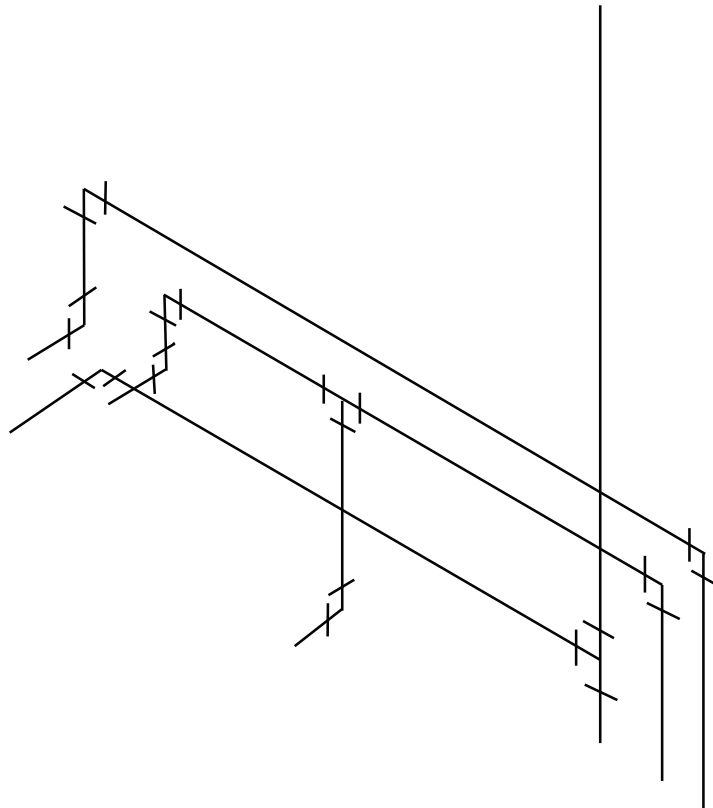

Figure 25—Isometric drawing of drainage and water lines

Evaluation Guidelines

Overall neatness:

- Lines are concisely drawn.
- Lettering is done to a high quality (all uppercase).
- Guidelines are fully erased to avoid confusion.

Drawing conforms to orthographic standards:

- Accuracy of drawing to actual object
- Alignment of views (top view above front view, for example)
- Correct use of symbols (fittings pointed away from or toward viewer)

Drawing conforms to isometric standards:

- Correct use of symbols (i.e., shoulders on fittings)
- Conformity to 30° planes
- Accuracy of drawing to actual project