



BOSCH

Invented for life

Driven by
originals

Bosch Classic

Quality spare parts by Bosch
for classic cars
Part of your life. Part of you.

BOSCH



Bosch Classic

Range of spare parts for classic vehicles

Mercedes-Benz 320 combination coupé version, 1937-1938

Tradition and passion for anything related to cars are the bedrock of Bosch Classic.

~~As a pioneer in the field of automotive engineering and a leading supplier of the automotive industry worldwide,~~ Bosch and its technical support allow maintaining classic vehicles.

From A to Z and alternator to wiper blade

Bosch features a wide range of spare parts for classic and modern-era classic cars. Some older components are still on stock, some are still produced and for some there are substitutes. In addition and in the context of reengineering projects, some parts are also reproduced maintaining their historical design, but equipping them with modern technologies. In this way, future reparability and spare parts supply are ensured.

This brochure will provide you with a brief overview of the range of Bosch products for classic and modern-era classic cars.

Component remanufacturing

At Bosch Classic, spare parts supply for classic vehicles is also ensured by means of remanufacturing. For this purpose, owners of historic vehicles can fully rely on a comprehensive range of Bosch eXchange parts and selected products provided by the 1:1 REMAN service. When it comes to keeping classic and modern-era classic cars running and on the roads, the topic of electronic components is of constantly increasing relevance. By means of remanufacturing and repair of electronic components and control units, Bosch Electronic Service thus also contributes to long-term spare parts supply.



”Our products have always been our best advertisement.“

Robert Bosch’s statement shows his high demand on product quality and his strong customer-orientation. A promise, Bosch still lives up to today.

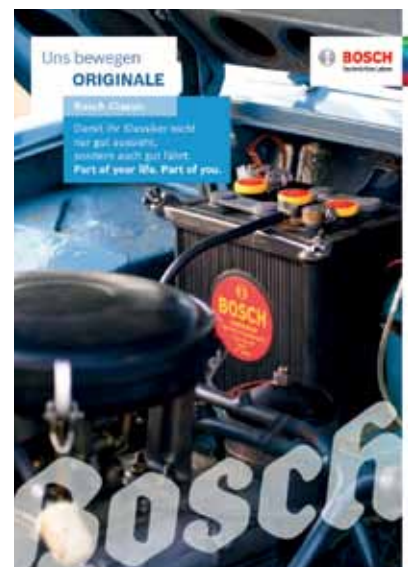

Bosch advertisement for batteries from 1938–2020

Ignition systems: From the magneto ignition to battery ignition systems

Tradition of progress: the ignition posed one of the biggest technical problems in the early days of automotive engineering. Robert Bosch had the solution at hand in 1897 – he managed to adapt a magneto ignition to a vehicle engine. Ever since, Bosch stand for progressive ideas and exemplary technology, especially in the area of ignition systems for Otto engines.

High voltage and spark plug

In 1902, Bosch filed a patent for the high voltage magneto ignition including the spark plug. The voltage was conducted to the spark plug via cable connections. The spark plug itself was actually nothing more than an auxiliary product, which Bosch had to produce in order to offer a complete system. However, it became one of the largest successes in Bosch's product range.

Cheaper with battery ignition

In 1930, a magneto ignition for a medium-sized vehicle cost about 200 Reichsmark, which then used

to be twice a Bosch worker's monthly wage and one tenth of a small-sized vehicle. Therefore, Bosch decided as of 1920 to further develop the battery ignition. For starters, mainly battery ignition systems for small- and medium-sized vehicles were supplied, consisting of ignition coil, ignition distributor and spark plugs with cables.

Ignition coils, ignition modules, ignition lines and spark plugs – the complete ignition system provided by Bosch

Today, Bosch offers its partners worldwide a complete program of all ignition components – also for classic cars.

At the Prince Henry Tour 1908, Bosch was represented with a refreshment station. Robert Bosch himself welcomed the arriving drivers. And whoever had a Bosch magneto ignition, was given a refreshment.



Ignition coils

Transformer stations for ignition systems

Bosch's product range includes different types of ignition coils for different applications. They operate with or without initial voltage boost in contact-controlled and contactless ignition systems.



Asphalt ignition coils

As fit as ever: the asphalt ignition coil has been produced in Bosch quality for several decades. This type of ignition coil is installed in many classic vehicles and owes its name to the fact that isolation and mechanical fixing of the inside windings are realized by means of asphalt.

- ▶ **Thanks to their large power reserves,** asphalt ignition coils guarantee a high running performance and a great starting behavior.
- ▶ **Even in case of extreme cold starts,** asphalt ignition coils are ignition-proof.
- ▶ **The replacement** of asphalt ignition coils is very easy.



i Multiple spark and compact ignition coils – future young classics

Many young classics are equipped with modern follow-up generations like multiple spark or compact ignition coils. They complete the Bosch Classic product range for future classics.

Ignition distributors

It's the small things that make a difference

Often it's the small spare parts that are hard to come by. Bosch offers a complete program for ignition components. It includes wear parts like ignition distributor caps, rotors, contacts, capacitors, some of them as reproductions.



Ignition distribution cap

There is high voltage under the ignition distribution cap. Up to 30 000 volt is applied to the parts under voltage. The distributor rotor located under the cap, the ignition energy of the coil is transferred to the spark plug via the ignition cables.



Impulse generator

The contact-less impulse generators replace the mechanical ignition contacts in the distributor. An external switch boards picks up the signal by the impulse generator and activates the ignition coil.

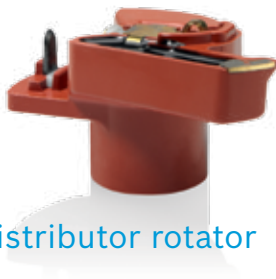

Ignition distributor rotator

Like the distributor caps, also distributor rotors must be immune to creepage currents. They are therefore made of the same material. Distributor rotors are used with or without limitation to the engine speed.



Ignition capacitors

Ignition capacitors prevent the ignition contacts to burn prematurely by averting an undesired electric arc on the ignition contact.



Ignition contact set

Ignition contacts – also called breaker contact – are subject to extraordinarily high stress. They have often gone through more than 100 million cycles of operation before being replaced.



Ft 1 v 4 high-temperature contact grease

Highly adhesive contact grease

The heat-resistant and particularly adhesive Ft1 v 4 high-temperature bearing grease is used to lubricate ignition contacts of ignition distributors. To increase the service life of ignition contacts, numerous vehicle manufacturers recommend using bearing grease.



Ignition cable sets and spark plugs

The perfect selection for a perfect ignition

Bosch quality fits: the broad range of ignition cables and spark plugs by Bosch are attuned to the different vehicles.



Ignition cable set

Bosch ignition cables are very robust and resistant against heat, cold and liquids. The connecting plugs are corrosion-resistant and thus offer reliable electrical contact.

Silicone is used for the outside insulation. This contributes to excellent radio interference suppression and a long service life.



Spark plugs

Bosch spark plugs impress with their extremely high quality, reliability and performance.

Bosch Super 4 spark plugs are an alternative recommendation for older passenger vehicle models. Their air/surface-gap spark technology make them especially resistant against sooting.

i Spark plug connector
Ignition coil connector
Ignition distributor connector

Bosch offers spark plug connectors in different offsets and wrench sizes for young classics and vintage cars. Also ignition coil connectors and ignition distributor connectors are part of the program.



i Find alternative solutions for historical spark plugs by way of type designation

The type designation for spark plugs was facilitated at the end of the 1970s. A comparison between the old and the current type designations can be found under:

www.bosch-classic.com



Batteries

Charge, install, start.

Vehicle batteries store electricity and discharge it when needed. While driving, the battery is charged by the generator; at a stop, the battery supplies electrical consumers such as the starter and radio with energy.



Starter battery, classic

Whereas batteries in the 1960ies used to be made primarily of hard rubber, plastic (PS) is used today. Batteries with plastic casings minimize gas penetration and prevent the formation of corrosion on poles and bridges. They are less likely to break and can be recycled almost completely. The backfire protection included in the seal plugs provides additional safety. Classic batteries are

delivered in dry and precharged condition. After charging the battery with battery acid, which has to be ordered separately, it can be used shortly. Due to the original design, Bosch batteries for classic vehicles are optical highlights, however, they also offer a longer service life and a higher starting performance by way of the state-of-the-art technology inside the battery casing.

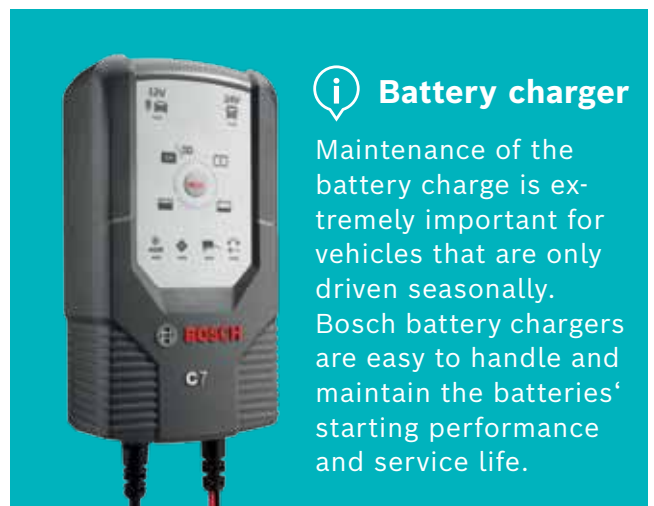
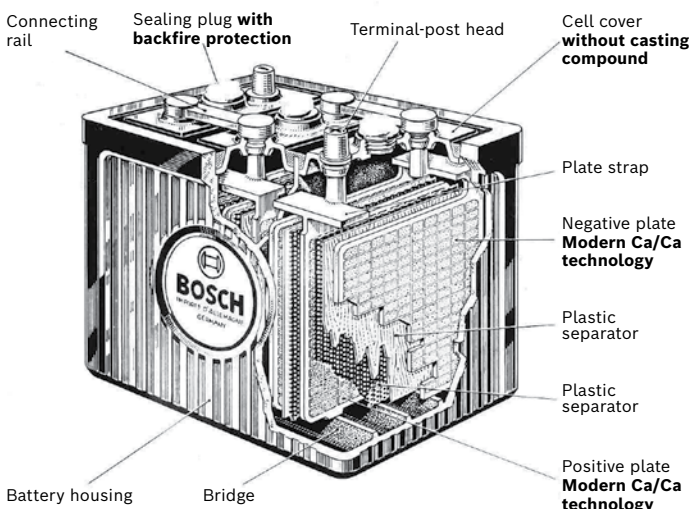

Starters and alternators

A strong start and reliable supply

Bosch has over 100 years of experience in the development and manufacture of starters and alternators. Know-how that pays off – for vehicle owners and workshops.



**Bosch
Classic
solution**

Starters

Bosch starters stand for strong performance, a long service life, first-class quality, and reliability. The product portfolio includes a broad range of innovative starters – robust and sophisticated solutions for gasoline and diesel engines that practically fulfill the requirements of all classical vehicles and that offer the highest starting reliability, even under extreme conditions.

Alternators

The higher the efficiency factor, the more effective the alternator and the lower the fuel requirement to produce the electrical energy. Furthermore, Bosch alternators are extremely reliable and have a long service life. They provide high performance and are produced and tested under the same conditions as original parts.

**Bosch
Classic
solution**

DC generator governor



The generator governor is responsible for voltage control and current limiting to protect the alternator.

Starters and alternators Bosch eXchange classics

When remanufacturing starters and alternators, state-of-the-art production technology is used to replace all wear parts and critical components. The high quality standards and functional tests in certified plants guarantee the high quality. Therefore, Bosch awards the same warranty as for new products.

Iconic thanks to Jetronic: Renault 5 Turbo 2



Photo: Andy Morgan

History of the Jetronic

The launch of the electronically controlled Jetronic took place first in the USA, where new exhaust gas standards became a requirement of the important Californian market. In general, however, there was still plenty of doubt regarding the system's sustainability. In order to be able to also supply mechanically controlled injection systems, Bosch developed the mechanical equivalent K-Jetronic parallel to the electronic

successor L-Jetronic. Both of them were launched onto the market in the early 1970ies.

Tighter emission laws worldwide ensured that the electronic fuel injection finally prevailed. The Jetronic thus provided impetus to the success of electronic systems and attached great importance to electronics in today's cars.

Market launch of Bosch gasoline injection systems

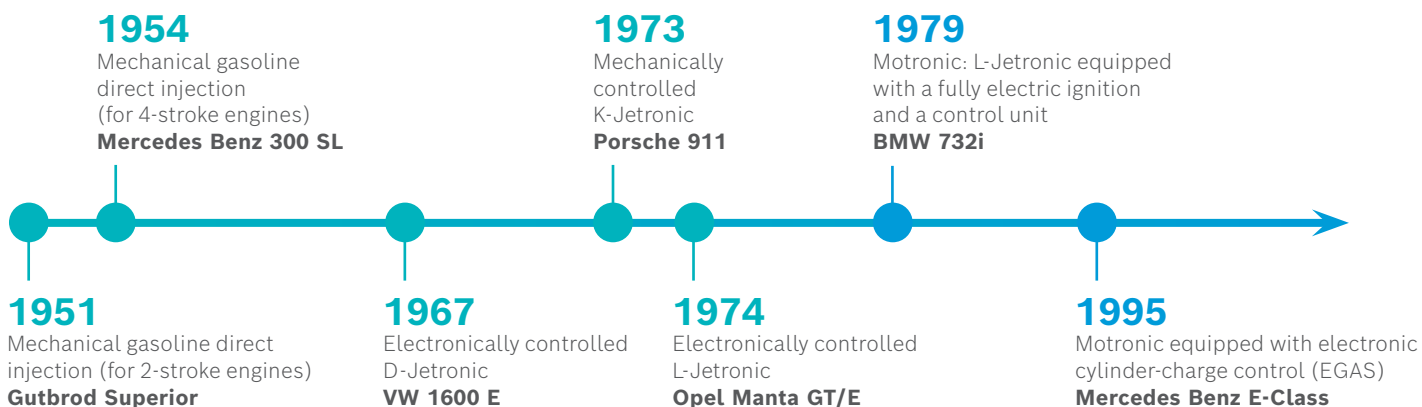

Fuel supply

Everything runs smoothly with Bosch

Convincing quality and reliability: pump modules as complete solution or fuel pumps – Bosch systems for the fuel supply of classic vehicles offer performance and safety on the level of new vehicles.



Side channel pump

Gasoline injection systems by Bosch were already used in 1954 in the legendary Mercedes Benz 300 SL. The used side channel pump is the first fuel pump made by Bosch. It conveys the fuel to the in-line fuel injection pump.

The production of the side-channel pump has remained the same since it was first introduced.



Electric fuel pumps

In 1966, Bosch developed the first electric fuel pump from a roller cell pump for fuel oil burners, which is used to this day in historic injection fuel systems.

Another milestone was the introduction of the peripheral pump (flow pump) in 1985, which gradually replaced the roller cell pump.



i Fuel tank and safe pressure regulator

After the engine has been switched off, the fuel tank maintains the pressure in the fuel system for some time to facilitate the re-start of the engine that is still warm. The electro-hydraulic safe pressure regulator of KE-Jetronic allows the implementation of warm-up control, overrun fuel cut-off and speed limit.

Fuel metering

Fuel – precisely distributed

Classic vehicles will take you on a journey through the history of fuel injection:

as a forerunner for gasoline systems, Bosch is the only one to offer a complete product range from individual components to complete injection systems.

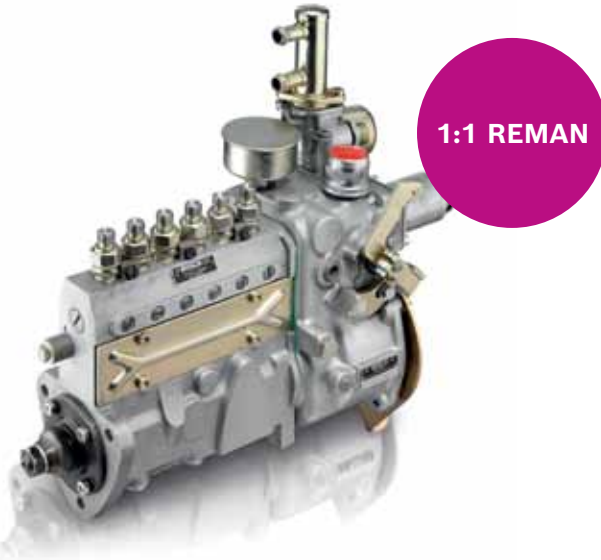

Mechanical fuel injection

Already in the 1950s, the mechanical fuel injection, compared with Otto engines, increased performance and reduced fuel consumption. Until today, the individual components are repaired by Bosch.



Fuel distributors

The fuel distributor is the central element of the K- and KE-Jetronic by Bosch. It is mainly controlled by the airflow meter and responsible for the fuel metering of the individual fuel injectors. The core of the injection system is repaired in specialized Bosch workshops.



Mechanical and electric fuel injectors

Fuel injectors are essential components for injecting gasoline. They are responsible for dosed injection, fuel distribution, forming the injection process and sealing against the combustion chamber.



Warm-up compensators



The K-Jetronic warm-up regulator ensures a good cold-start behavior and controls functions such as the acceleration and full-load enrichment.

Sensors

A vehicles' sense organs

Sensors measure, feel, smell and count. Sensor signals are essential for many measurement and control functions as well as for safety and comfort reasons.



1:1 REMAN

Pressure sensor

The pressure in the intake manifold of the engine fluctuates and is measured by the intake manifold pressure sensor (pressure sensor). Using this information along with signals from other sensors, the control unit of the D-Jetronic calculates the optimum amount of fuel for each load and supplies this fuel to the fuel injectors.



Flow Meter

Air and fuel must be added to the engine in a precisely defined ratio. To do so, air flow meters measure the actual air flow and forward the measured values to the engine's measurement and control technology.

 **Lambda sensor/gas sensor**



The oxygen sensor has helped reducing motor vehicle emissions since 1976.



 **Repair kit
impulse generator
D-Jetronic**

Within the ignition distributor, the impulse generator measures the engine speed. Combining it with other values measured by additional sensors, the D-Jetronic control unit determines the proper injection timing and the amount of fuel to be injected.

Bosch and the diesel engine

Start of the diesel pump development

1922 marked the official beginning of the development of the diesel injection equipment. Bosch also benefitted from its experiences with lubrication pumps, which were being used for engine lubrication in vehicles and stationary engines.

From in-line fuel injection pumps to distributor fuel injection pumps

By 1950, Bosch had produced one million in-line fuel injection pumps and the success continued. However, the large in-line fuel injection pumps were hardly suitable for small engines in low-priced small-sized vehicles. Therefore, Bosch switched to distributor fuel injection pumps in 1962.

With the development of the Golf Diesel, Volkswagen geared to small, efficient diesel vehicles, bringing size and low price of distributor fuel injection pumps into play again. The launch of the Golf Diesel in 1976 downright triggered a sales boom for diesel models in the compact class.

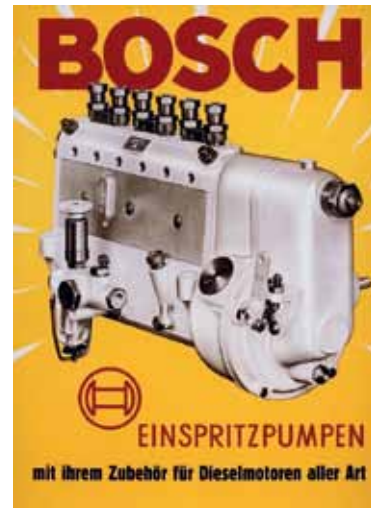

Advertisement for diesel injection pumps and accessories in 1949

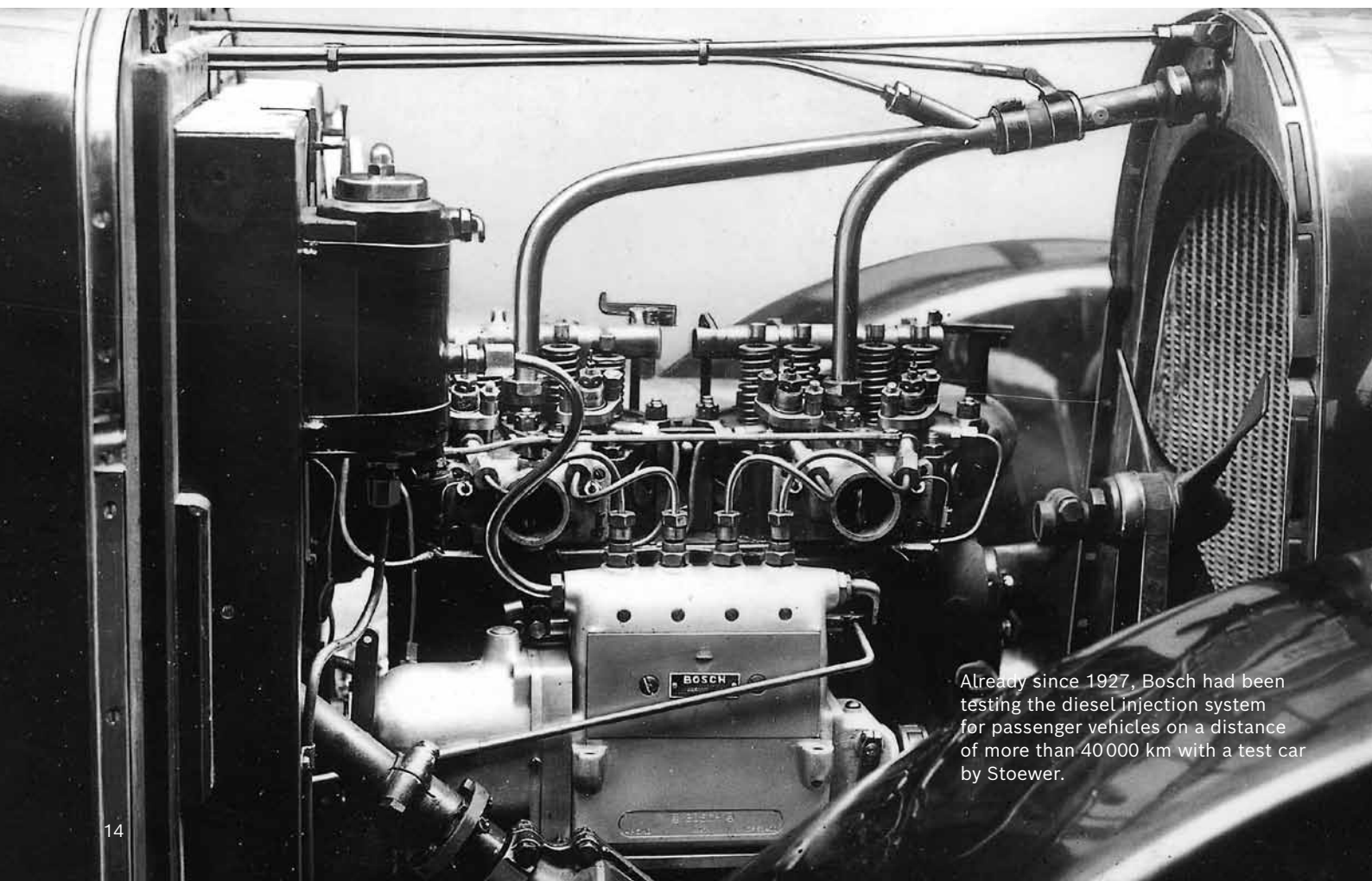

Already since 1927, Bosch had been testing the diesel injection system for passenger vehicles on a distance of more than 40 000 km with a test car by Stoewer.

Diesel injection Everything for the compression-ignition engine

No other name is more closely connected with the **development and capacity of diesel systems** than Bosch. Each individual component contains Bosch's entire diesel know-how.



Diesel in-line fuel injection pumps and regulators

Because the in-line fuel injection pump is lubricated via the engine oil circuit, it can also manage fuel of lower quality. Long-term reliability and a long service life are guaranteed if the vehicle is serviced regularly and Bosch spare parts are installed correctly. Pumps and regulators were constantly improved. Important milestones for today's pumps were the Electronic Diesel Control (1987) and the control-sleeve in-line fuel injection pump (1993).



Distributor fuel injection pump

Small, fast-running diesel engines in classic cars require an injection fuel system with high efficiency, fast injection sequences, low weight and a small mounting volume. The distributor fuel injection pumps fulfill this requirement.

Since 1962, Bosch has produced more than 45 million distributor fuel injection pumps. Their types and the structure of the entire system are correspondingly diverse.



Nozzle holder assembly and diesel fuel injection nozzle

Fuel injection nozzles are used to precisely nebulize the fuel and to distribute in such way that the combustion procedure runs perfectly. The nozzle holder serves to affix the injection nozzle in the cylinder and connect with the fuel line.



BOSCH

Diesel Center



BOSCH

Diesel Service

The Bosch Diesel Center und Bosch Diesel Service have an excellent reputation as competence centers for all aspects regarding repair and maintenance of diesel fuel injection systems. They are the contact for authorized workshops, fleet operators, business customers and private vehicle owners.

Glow plug systems

New classics and vintage cars with diesel engines

Bosch is today's worldwide production leader of glow plugs and glow plug system technology. Bosch offers glow plugs for almost all classical passenger cars, trucks and agricultural vehicles with diesel engines.



Glow plugs by Bosch

Glow plugs guarantee comfortable starts, a stable cold run and thus lower emissions. They should be checked for functionality by an expert on a regular basis as they are wear parts. If the glow plug has to be replaced, Bosch offers the right solution for each vehicle type – depending on the system, made of metal or ceramics and with the appropriate heating element diameter.

Bosch glow plugs have replaced the historic coil glow plug almost altogether. They combine operating voltage, maximum glow temperature and duration of afterglow. Their resistance against chemical, mechanical and thermal stress is high, just like their service life.



Glow time control device

Glow systems in young classics are usually equipped with glow time control devices. Their functionalities go beyond the mere starting process and affect the vehicle's consumption and emissions by way of active electronic control.

Glow plug starter switch



Bosch supplies different types of glow plug starter switches for diesel vehicles. They are equipped with a safety lock and installed so that do not twist.

Electronic Control Units

Computer for gasoline and diesel engines

Electronic engine controls enable precise central management of all functions relevant for engine operation regarding constant driving characteristics and emission values throughout the entire service life.



Electronic engine controls

While driving, the control unit permanently monitors and diagnoses all components that affect the safety of the system and the emission behavior. Thus, the engine control in the fuel and diesel system is the core of the linked individual components that attunes them and makes for optimal drivability.



Ignition distributor

The pictured control unit for the high-voltage capacitor ignition (HKZ) was developed for high-revving and powerful reciprocating and rotary piston engines. It stands out due to its virtual insensitivity against electrical shunts like dirty spark plugs.



Bosch control units

Overview of systems

- ▶ D-Jetronic
- ▶ K-Jetronic with Lambda control
- ▶ KE-Jetronic
- ▶ L-Jetronic
- ▶ Motronic
- ▶ Antilock braking system ABS
- ▶ Transmission control unit

Control unit repair with all-round service



www.bosch-repair-service.com
Find out more on page 33

Wipers and cleaning systems

For a better view

A better view in the long term – with windshield wipers by Bosch. They can be installed quickly and guarantee less wind and wiping noises, making them the perfect fit for every weather – and thanks to the broad product range, also for almost every vehicle.



Window cleaning

Bosch windshield wipers are being put to use wherever special resistance against climatic conditions is required. Robust metal holder system and multiple corrosion protection make them very tough and durable.

Thanks to their intelligent adapter system, Bosch windshield wipers are installed easily and quickly on classic cars.

Window cleaning products

- ▶ Wiper arm
- ▶ Wiper blade and blade rubber
- ▶ Wiper motor
- ▶ Electrical water pump
- ▶ Wiper interval switch
- ▶ Relay for wiper motors and wiper interval functionalities

Wiper motor



Perfectly adapted to the wiper system for efficient, reliable window cleaning.

Wiper interval switch



Retrofitting comfort: Switch with adjustable wipe interval in 6, 12 and 24 Volts.

Filters

The world of filtration for classics

Bodyguard for the engine: Filters have an important protective function for both gasoline and diesel injection systems. The Bosch filters produced with high technical effort reliably protect engine components against dirt particles and abrasion.



Fuel filter

Smallest particles on the injection system may lead to wear and early failure. Bosch fuel filters filter impurities, thus guaranteeing optimal functionality and a long service life.

Air filter

Bosch air filter reliably clean the suction air from particles. This protects the engine components from early wear and support an optimal engine power.

Oil filters

Bosch oil filters keep soot and metal abrasion on the inside, thus preventing them from circulating in the engine's oil cycle – for maximum service life.

Cabin filters

Bosch cabin filters clean the air from pollen, fine dust and hazardous, malodourous gases and guarantee an easygoing driving experience in every season.



Supertone horns and lighting

Pioneer for safety equipment

Light, sight and the possibility to make yourself seen are prerequisites for safe and relaxed driving – also in classic cars. Bosch offers a wide variety of vehicle lamps for different requirements and acoustic alarm for almost every vehicle.



Supertone horns

Horns make it possible for the driver to warn other drivers, particularly in hazardous situations. Bosch horns are manufactured using a historical design which includes slotted screws and a chrome-plated cover, i.e. the visuals hardly differ from the original horns from the 1950s and 60s.



Bulbs for classic cars

In both, modern and vintage cars – Bosch vehicle lamps are of high quality and are awarded top ratings by drivers on a regular basis. Depending on the vehicle's age, either double filament or halogen lamps can be used for the head lamps.

Test vehicle with different light and signal systems (1954)

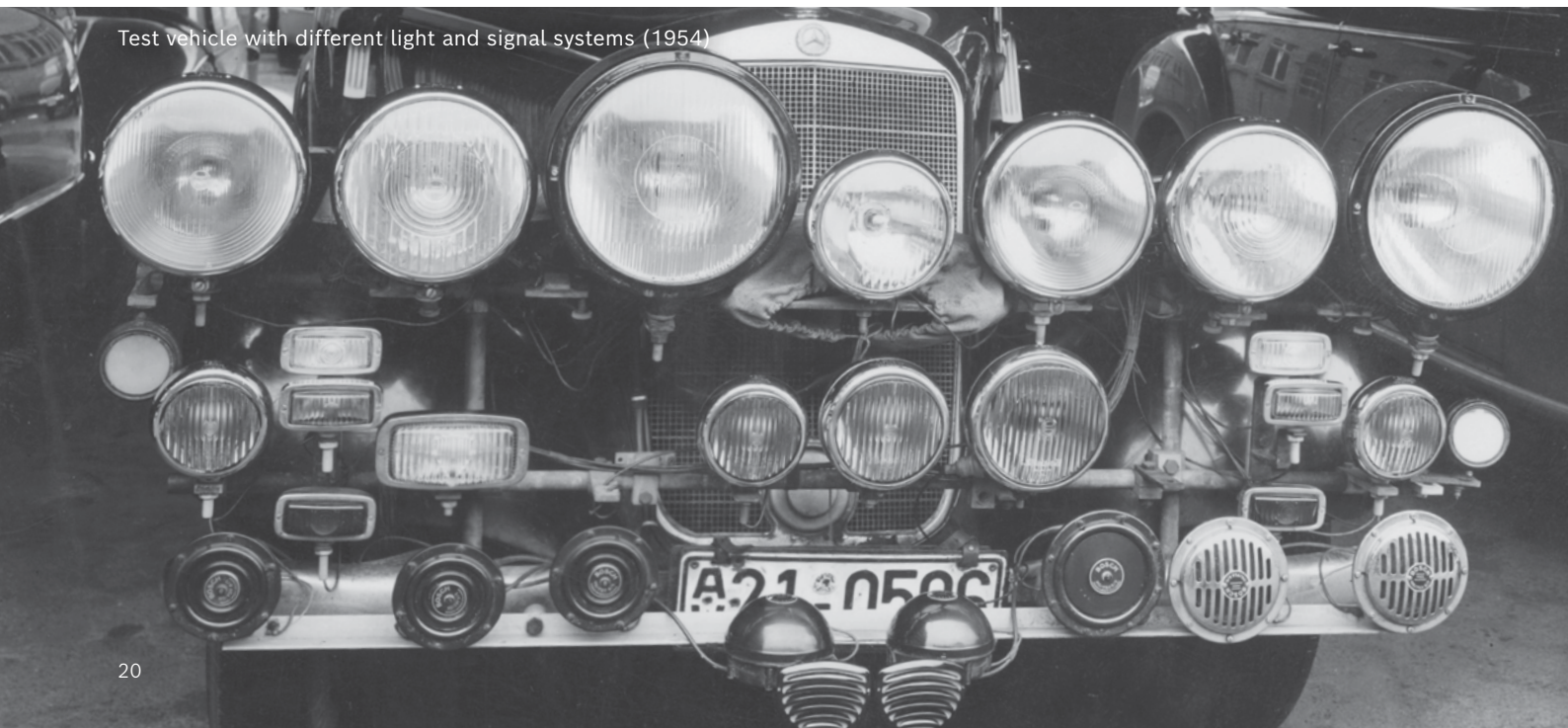

Headlights and lenses

Made with the original tools

Headlights and lenses are particularly important for classic fans. Because the originals are often very worn and can no longer be obtained. The new edition of Bosch headlights – made with the original tools – therefore help to maintain the car value.



Headlights and lenses

Headlights are always subject to environmental influences and thus heavy strains. Stone chips can cause corrosion on frames and result in broken lenses – not to mention foggy headlights. Due to the high demand, Bosch Classic relaunched historic Bosch headlights produced on genuine tools. The first headlights available will be black and chrome Porsche 911 headlights – with histo-



rically correct Bosch lettering – for models built between 1968 and 1982. Afterwards, the range will be expanded adding headlights for additional vehicle types.

In addition, the Bosch Classic range also includes lenses for the headlights of numerous other vehicles.



Foot/rotary switches

Foot and rotary switches for high and low beam switch without interruption and snap in at the selected position. They feature a corrosion-resistant surface.



Switches

User-friendly operation in classic cars

Bosch switches offer exemplary quality and a long service life. A host of designs are available for a wide range of purposes: From pressure switches for reliable starting to retrofittable wiper interval switches to improve vision while driving in the rain.



Switches

Switches enable easy and comfortable operation of technical systems in classic cars. Ignition, driving light or blinker – there is a matching switch for every function. As the leading company in the area of vehicle electrics and electronics, Bosch offers a wide variety of vehicle switches for modern classic and vintage cars.

Switches for classic vehicles

- ▶ Blinker switch
- ▶ Brake light switch
- ▶ Push switch
- ▶ Glow plug starter switch
- ▶ Light switch
- ▶ Oil pressure switch
- ▶ Warning switch
- ▶ Wiper interval switch
- ▶ Ignition starter switch

Blinker unit and relay

The right interval, correctly connected



Blinker unit

Blinker units come in different shapes and switches, however, they all serve one purpose: to indicate the driving direction by means of bulbs inside the blinker units. The functional control is performed with optical and acoustic feedback. Blinker units by Bosch have been designed to still function reliably after many cycles of operation.



Relays

Relays for classic cars are being out to use for the most different purposes, e.g. to switch between high beam and low beam lights. Bosch relays do not need a lot of space and have a high switching capacity. They are very reliable and have to be replaced no earlier than after about 250 000 cycles.

A glimpse into the cockpit of the Fendt carrier plate F225GT (1961-1965): heater plug control, push key, turn-switch for light, pull switch and glow plug starter switch – everything made by Bosch.

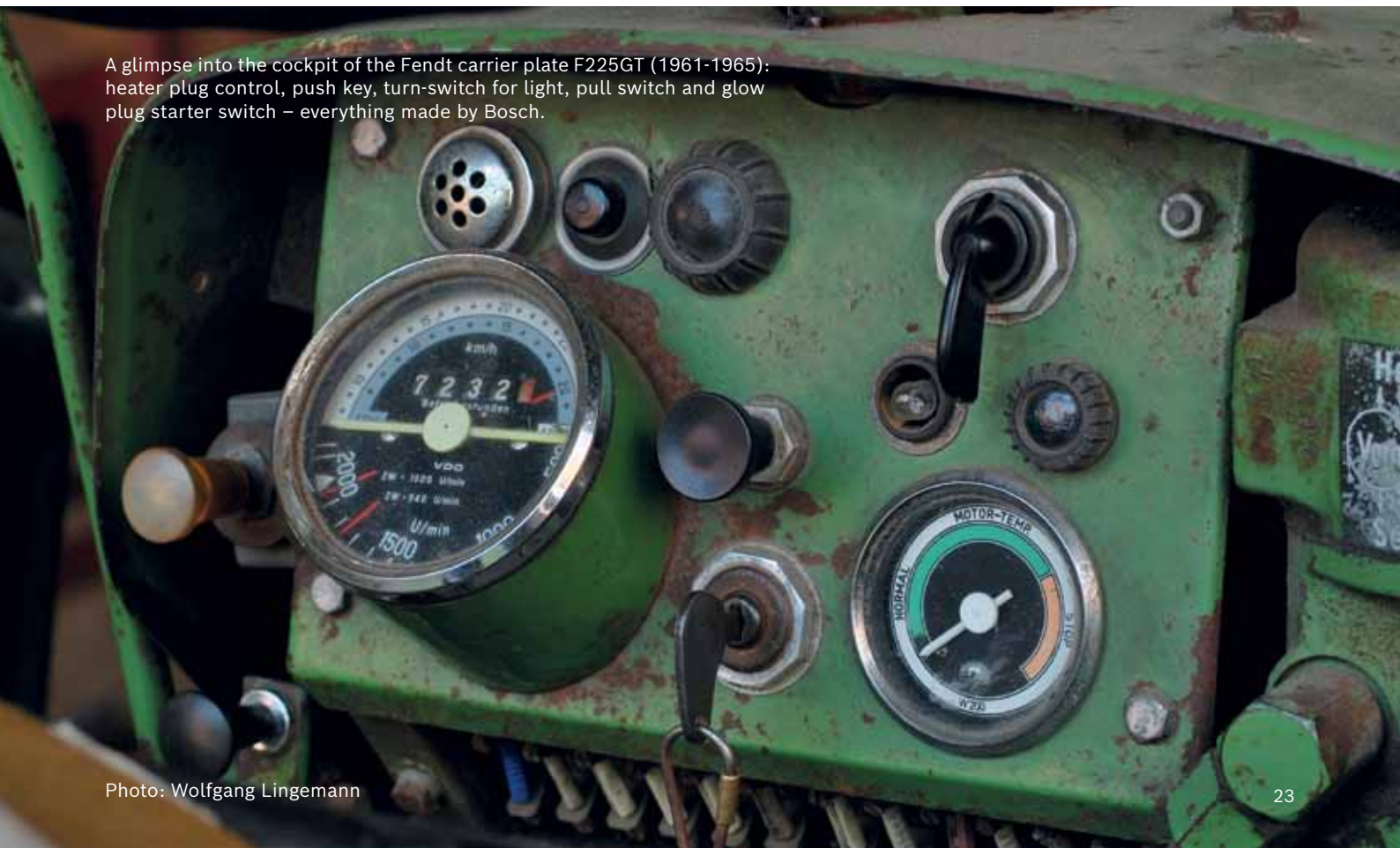

Engines

Vehicle safety made by comfort

Sunroof, seat adjuster or window lifter – Bosch offers the perfect solution for diverse requirements and for almost all vehicle types. Therefore, Bosch supplies electric engines for many classic cars.



Glass rinse motors

Together with the wiper blades, glass rinse engines provide for a clear view in all weathers. The small water pressure pumps convey the wiper fluid from the respective container via the nozzles onto the windshield.



Sliding sunroof motors

Bosch sliding sunroof drives and intelligent operating concepts enhance comfort and allow the driver to concentrate fully on traffic conditions.



Window lifter motors

Window lifters increase comfort and safety for the driver. Bosch drives are equipped with self-locking gears, which avoids forceful opening of the glass.

 **Rocker switch**



Historically suitable for cars by BMW – the rocker switch that controls the individual window lifter motors.

Engine fan

With a good feeling and concentration on tour

Maximum concentration and a quick reaction are only possible if the driver feels comfortable in his car. This is way electric AC and heating systems make for the desired comfort.



Engine fan for cooling

Together with the electric water pump, the engine fan, which is controlled via a thermal switch, protects the engine from over-heating, also in stationary position.



Engine fan for heating

Bosch supplies the central element for vehicle heating: the fan. Fan wheels, casings and fan controls can be perfectly combined in the vehicles, thanks to their modular structure.



Electric water pumps

Electric water pumps circulate the water in the cooling circuit and, together with the cooling fan, protect the engine from locally over-heating.



Electric engine coil – precision delivers performance

Brake actuation

Come to a stop safely

Small effort – large effect: Bosch actuating devices guarantee a reliable braking force transmission due to the use of high-quality materials. They are subject to strict quality controls and form a coordinated system for all actuating components.



Brake master cylinder

Brake master cylinders must be and stay tight. Bosch brake master cylinders impress with their high quality and long service life. They are made of cast iron or aluminum. The high quality standard is ensured by strict controls and complex production processes. Optimized cylinder surfaces minimize abrasion of the pressure collars and help Bosch brake master cylinders to work reliably for a long time.



Wheel brake cylinder

Wheel brake cylinders by Bosch are made of cast iron or aluminum. These high-quality materials, together with narrow tolerances ensure a long service life and optimal functionality and tightness.

Brake system products

- ▶ Brake master cylinder
- ▶ Wheel brake cylinder
- ▶ Brake booster
- ▶ Repair kit
- ▶ Brake light switch

Brake cable and brake hose

Bosch transmission parts, such as brake cables and hoses fulfill all applicable standards and guarantee safety by means of a consistent transmission behavior.



Brake fluid ENV4



Compared with conventional DOT standards, ENV4 has a significantly lower viscosity and a higher wet boiling point. Like this, the brake system is able to operate at full capacity.

Vehicle safety systems

Master critical driving maneuvers

Electronic vehicle safety systems intervene to avoid accidents or minimize damage. With ABS, ASR and ESP®, Bosch is one of the forerunners regarding active driving safety. Originally conceived to be special equipment for luxury class cars, electronic driving safety systems are nowadays used in many modern classic cars.



Hydraulic modulator with ABS/ASR control unit

The antilock braking systems ABS detects that one or more wheels tend to lock and reduces the braking pressure. This enables the driver to avoid an obstacle and brake safely and quickly or bring the vehicle to a stop, even in case of a full braking. The traction control system TCS detects spinning wheels, reduces the engine power as a result and brakes individual wheels, if necessary.

Products for vehicle safety systems

- ▶ Hydraulic modulator, ABS/ASR
- ▶ Acceleration sensor, ABS
- ▶ Control unit, ABS/ASR
- ▶ Double piston accumulator ASR
- ▶ Wheel speed sensor
- ▶ Electronic engine control unit (EMS)
- ▶ Sensor for accelerator pedal position



Brake discs and pads

Braking without compromise

Thanks to high-quality materials, Bosch disc brakes are also reliable when it comes to extreme stress. Thus when fully braking, the brake power corresponds to a multiple of the engine power. Only high quality can endure these thermal and mechanical stresses.



Brake discs

As a premium manufacturer, Bosch has its own research, development and production facilities. Brake discs with a high temperature conductivity, fitting accuracy, and mechanical and thermal stability are produced there while adhering to extremely strict quality requirements.

Brake pads

Bosch develops individual brake pads, depending on the vehicle model, and always selects the pad mixture that ultimately results in a brake pad with perfect characteristics.



Brake calipers

Brake calipers by Bosch convert the hydraulic pressure, reliably dose the contact force and thus provide an optimal brake action. They are available for many classic cars.

Products for disk brake systems

- ▶ Repair kit brake caliper
- ▶ Warning contact lining wear
- ▶ Parts kit
- ▶ Accessory kit
- ▶ Sensor for accelerator pedal position

Brake light switch



Pneumatic, hydraulic or operated with oil pressure – Bosch supplies suitable brake light switches for classics.

Repair kits for brake calipers



Perfectly attuned repair kits for brake calipers guarantee safe functioning of the brakes following repair or service.

Drum brakes

Brake action for high demands

Bosch drum brakes are classics – especially for smaller-sized passenger vehicles – brake components are perfectly attuned – for high abrasion resistance, fitting accuracy, a long service life and maximum reliability.



Brake drums

Brake drums must be replaced when the thickness has dropped below the minimum value or cracks appear. Bosch has the perfect spare parts for the respective vehicle type. The materials are high-quality and all components have been attuned perfectly – for a long service life and high fitting accuracy.



Drum brake shoes and kits

Tested safety: drum brake shoes by Bosch are also reliable under extreme conditions. This is of special importance as drum brake shoes belong to those parts of a brake system that are exposed to the most stress. Abrasion, high temperature fluctuations and natural aging process constantly wear on the drum brake shoes. This is Bosch also offers drum brake kits for classic cars.



Wheel speed sensor



Passive, inductive sensor (inductive sensor) or active sensor with own electronic evaluation unit controls the antilock braking system.

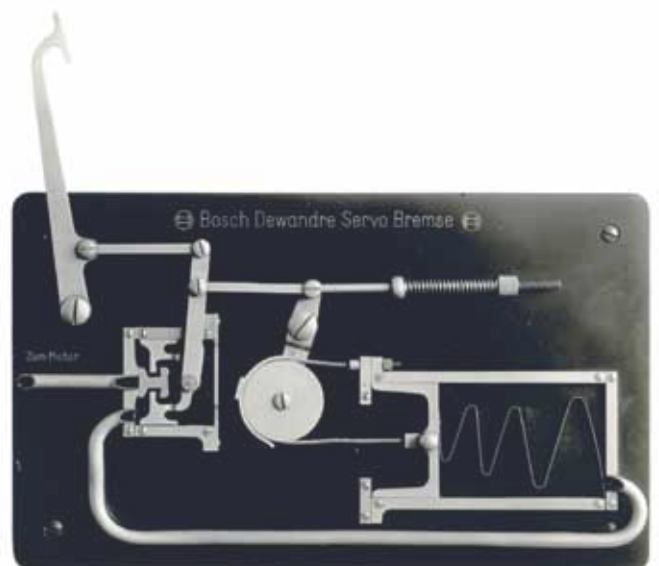

1927: The Bosch Dewandre power brake for trucks is launched – one year later also for passenger vehicles. Safe braking is now easier.

Wiring harness and service parts

Little helpers, big “rescuers”

Especially in classic cars, electric connections are subject to high wear over time. Bosch offers an extensive accessory program which is entirely state-of-the-art regarding functionality and safety.



Cable connectors, shrinking hose kits and vehicle cables

Secure connections and specified insulations on the electrical system of classic cars is an absolute necessity as this not only supports the driving safety but also maintains the value of the car. Therefore, Bosch has compiled a broad range of universally usable high-performance cable connectors, shrinking hose kits and vehicle cables.

Fuses and fuse boxes

Standard automotive fuses are the circuit protection standard for domestic and foreign passenger vehicles and trucks. They are easy to identify and to replace and can be specified for numerous applications in the low-voltage area.

Plugs and sockets

Bosch offers a broad range of plugs and sockets for the electric connection of drawing vehicle and trailer. Among other things, required disabling contacts for the rear fog lamps of drawing vehicles and installation equipment are included.



More than 1000 different types of drive belts for passenger cars



Bosch supplies high-quality drive belts, tensioner elements, idler and tensioner pulleys for classic vehicles that cope with the high strains they are subject to.

Bosch diagnostics

Test equipment and ESI[tronic] software

The team for modern and classic vehicles when it comes to the safe diagnosis of malfunctions.

Test equipment and ESI[tronic] software help to find errors and repair components.



Pressure loss tester, multimeter and timing light

The pressure loss tester is used to adjust the tester by means of high-pressure test hoses, a top dead center detector or a test nozzle. The battery-powered digital multimeter is used for voltage, current and resistance measurement with continuity test. The timing light equipped with a xenon flash lamp is designed for measurement and exact testing of the basic set-up of ignition distributors, ignition timing angle, centrifugal timing and vacuum-operated timing.

Measurement technology for professional system analysis and fault diagnosis

FSA 740 can be used to perform vehicle system analyses on numerous modern-era classic cars. The scope of delivery includes an electronic measurement module with oscilloscope and a sensor unit with signal generator. A fluid pressure kit and an emission analyzer are available for retrofitting purposes.

The device includes a neatly arranged menu structure with individual test steps and connection instructions. More than 50 preset components tests and vehicle-specific data are already included.



Bosch eXchange

High quality remanufacturing for classic cars

Bosch eXchange stands for 100% quality at a low price. The extensive and intelligent replacement program is the all-round solution for a timely and efficient repair of your vehicle – also for classic cars.

Cost and benefit – a strong argument for every vehicle owner

Although for most owners of modern classic or vintage cars, the “sentimental value of their car” is worth more than the economic value – everyone has to keep an eye on their financials. Bosch eXchange is the extensive replacement program for vehicle components. This allows for a timely and efficient repair also of classic vehicles, including the same guarantee as for new parts. Bosch applies the same high quality standards to remanufactured parts as it does to newly manufactured products. The dedicated and experienced



engineering team constantly focuses on fulfilling the strictest standards. After disassembly, the components are cleaned in line with environmental legislation. Every component and part then passes an intensive testing process. They undergo a visual, dimensional and electrical test. A 2-year guarantee is given to remanufactured parts the same as for new parts.

1:1 REMAN

Individual restoration service

With 1:1 REMAN service, Bosch Classic restores selected products.

The difference to Bosch eXchange is that the product delivered by the customer is restored and send back to the customer.

Special expertise for the value-preserving restoration of classic car parts

Testing and restoring is performed using original tools and testing techniques in Bosch plants. In the process, all wear parts are replaced. The product is tested and adjusted acc. to Bosch plant regulations. By restoring the product you sent, the originality of the vehicle is maintained. The restored part is subject to the same guarantee as a new part.



To be processed only via www.bosch-classic.com

Bosch Electronic Service

Reconditioning of electronic components

Bosch also offers automobile workshops an exchange and repair service for electronic vehicle components. Specialists who have collected their know-how by repairing thousands of electronic vehicle components, will carry out the repair.

Repair of faulty electronic components

Following a comprehensive diagnosis and determination of the respective defect, the workshop uses the service portal to identify the component by way of the Bosch number or device number. After the repair order has been placed, the defective part will be picked up from the workshop.

After the component has been delivered, our Bosch Electronic Service professionals carry out the repair. Usually, the repaired electronic component is on the way back to the workshop within 48 hours.

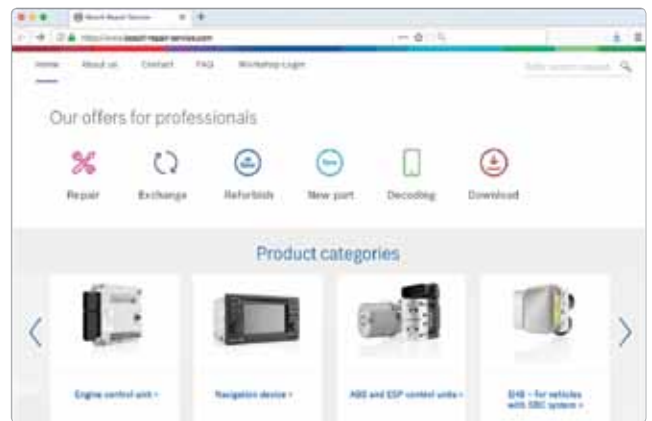

www.bosch-repair-service.com

Bosch Classic Service

New glamour for your classic

Bosch Classic Car Services offers services tailored to classics and supplements the product line of Bosch Classics. Every company in our network is qualified to offer customized service and repair for modern classics and vintage cars.

Brings classics back into shape

Bosch Classic Services is qualified to offer customized service and repair, and is consistent with the special requirements for equipment and expertise. Bosch Classic Services offers a variety of services in the areas of automotive electrics, engine management, injection, brakes, magneto ignition, carburetor repair and vehicle restoration.



Partner for your classic vehicle **Bosch Classic Service**

Technical training

You live and learn

To keep practical knowledge alive in relation to the maintenance and repairing of modern classic and vintage cars, Bosch Classic has created a range of technical training courses.

Theory and practice

Technology enthusiasts who own modern classic and vintage cars can attend technical training courses on classic Bosch systems. In addition to the intensive theoretical background, technical knowledge is communicated with hands-on examples on the vehicle.



Register at www.bosch-classic.com

Bosch technical literature

Technology, clearly explained

Then as now, Bosch conveys first-hand special knowledge. Information by Bosch on vehicle technology are available as book series *Bosch Fachinformation Automobil*, as reference work *Kraftfahrtechnisches Taschenbuch* and as wall charts (in German).

Knowledge pool for professionals and fans

Background knowledge should be practically applicable. Therefore, Bosch specialist books offer first-hand expertise and are ideal for self-study or for reference work in the workshop. Completely tailored to the need for practical background knowledge, the car specialist finds detailed information, which help understanding historical and modern vehicles. At the same time, the information is structured in such way that readers who are new to the topic will also become familiar.

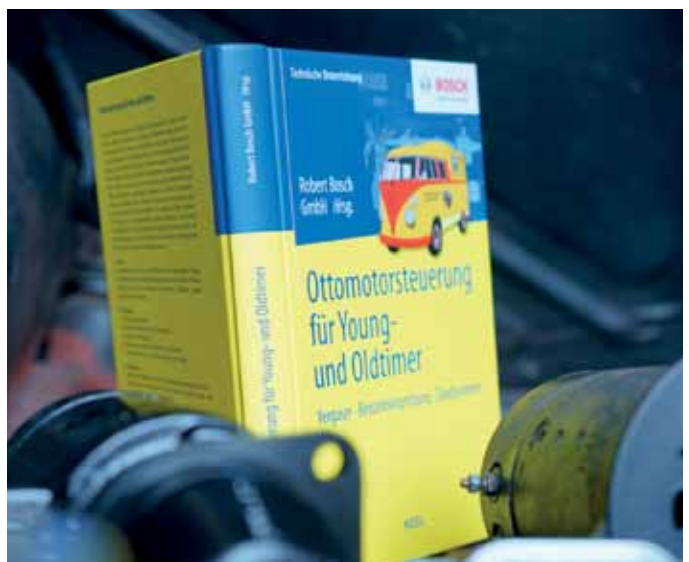

Gasoline engine control systems for vintage and modern classic cars

Your questions

Answered by Bosch Classic

Any questions? To reach the Bosch Classic hotline, call **+49 721-942-1660** (Monday to Friday, 8 am to 5 pm) or send an e-mail to **classic@bosch.com**. Please keep any required data about your classic or modern-era classic car on hand.



There are different channels available to order spare parts for classic vehicles.

Your order

Bosch Classic takes care



How to order spare parts



Private buyers place their orders with their local Bosch Service center.

You may also have a Bosch Classic Service center install the part in your vehicle, if you do not want to do so yourself.



As a workshop, please order at your wholesaler.

Directly contact Bosch Classic only regarding special processes like the restoration service 1:1 REMAN.



Wholesalers order products directly from Bosch Automotive Aftermarket.

There is no special sales channel for classic products.

Every future needs a past

Our vision guides us. It tells us what motivates us and where we want to go.

The guiding principle **Every future needs a past** cites and connects technological innovation, social competence and the tradition of the Bosch brand. We live our corporate values of responsibility, sustainability and reliability and fill them with fascinating content.

We are a passionate and agile team that develops outstanding products and services for today's and tomorrow's drivers of modern classic and vintage cars. We connect and accompany our customers and everyone who shares our passion for classic vehicles into the future.

We bring fascination and the creative inventive talent by Bosch to life – a fact that is conveyed perfectly by the guiding principle of Bosch Classic.

Part of your life. Part of you.

Find current information on www.facebook.com/bosch.classic or in our newsletter

www.bosch-classic.com

**What drives you,
drives us**



Robert Bosch GmbH
Automotive Aftermarket
AA-TR/ATR

Auf der Breit 4
76227 Karlsruhe
Germany
www.bosch-classic.com



BOSCH
Invented for life

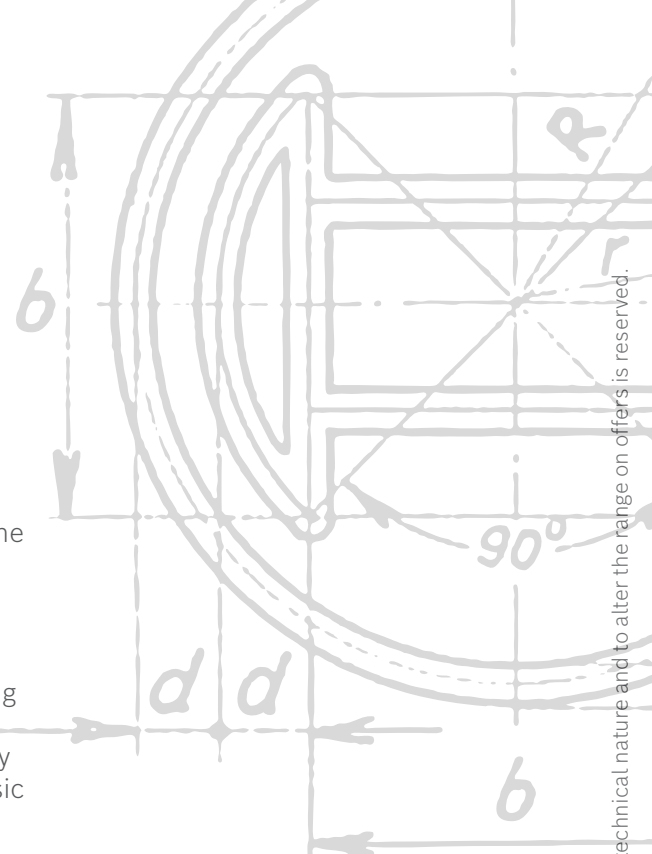

Bosch