

DUAL LITE

Dual-Lite
User Manual



TRX Series



HUBBELL LIGHTING, INC.

MANUFACTURER SUPPORT

For information or repair service in the United States, call 800-543-2378. A complete range of startup services, repair services, preventive maintenance plans and service contracts are available.

Please have the following information available:

Tag Number: _____

Site ID: _____

Part Numbers: _____

Serial Numbers: _____

Rating: _____

Date Purchased: _____

Date Installed: _____

Location: _____

TABLE OF CONTENTS

MANUFACTURER SUPPORT	2
IMPORTANT SAFETY INSTRUCTIONS	1
GLOSSARY OF SYMBOLS	3
1.0 INSTALLATION	4
1.1 External Inspections	4
1.2 Internal Inspections	4
1.2.1 Storing for Delayed Installation	5
1.3 Preliminary Checks	5
1.3.1 Identification	5
1.4 UPS Location	5
1.4.1 Positioning the UPS	5
1.4.2 Environmental Considerations	5
1.4.3 Special Considerations for 1+N Systems	6
1.5 Considerations in Moving the TRX	6
1.6 Mechanical Considerations	6
1.6.1 Clearances	7
1.6.2 Floor Installation	7
1.6.3 Cable Entry	7
1.6.4 Optional Cabinets	8
2.0 ELECTRICAL CONNECTIONS	9
2.1 Power Cabling	9
2.1.1 Cable Rating	9
2.1.2 UPS Input Configuration	10
2.1.3 Cabling Guidelines	10
2.1.4 Cable Connections	11
2.1.5 Safety Ground	12
2.1.6 Protective Devices	12
2.1.7 Cabling Procedure	13
2.2 Control Cables	14
2.2.1 Monitor Board Features	14
2.3 Dry Contacts	15
2.3.1 Input Dry Contacts	15
2.3.2 Maintenance Bypass Cabinet Interface	16
2.3.3 BCB Box Interface	16
2.3.4 Output Dry Contacts	17
2.3.5 EPO Input—Optional	17
3.0 BATTERY INSTALLATION	19
3.1 Introduction	19
3.2 Safety	19
3.3 UPS Batteries	19

3.4	External Battery Cabinet Installation	20
3.4.1	Matching Battery Cabinets	20
3.4.2	Connecting the Batteries	20
3.4.3	Installation Considerations	22
3.4.4	Connecting the Battery Cabinet to the UPS	24
3.5	Non-Standard Batteries	24
4.0	MAINTENANCE BYPASS CABINET	25
4.1	Bypass Switch	25
4.2	Normal (UPS) Mode	25
4.3	Bypass Mode	26
4.4	Maintenance Mode	26
4.5	Locating the Cabinet	26
4.6	Cable Installation	26
4.6.1	Wiring Preparation	26
4.6.2	Power Cable Installation	27
4.6.3	Input/Output Wiring	27
4.7	Bolting Cabinets Together	29
5.0	OPTION INSTALLATIONS	30
5.1	Load Bus Synchronization	30
5.1.1	Performance Requirements	30
5.1.2	DBS Cable and Settings	30
5.2	Configuring Parallel System Operation	31
5.2.1	General	31
5.2.2	Features of Parallel System	32
5.2.3	Operating Principles	33
5.2.4	Operation Modes Summary	33
5.3	Installing Parallel System	33
5.3.1	Conditions for Parallel System	33
5.3.2	Cabinet Installation	33
5.3.3	Preliminary Checks	33
5.3.4	Protective Devices	33
5.3.5	Power Cables	34
5.3.6	Parallel Control Cables	34
5.3.7	Emergency Power Off (EPO)	36
5.4	Battery Circuit Breaker Box	36
5.5	Battery Start	38
5.6	Remote Alarm Monitor	38
5.7	Analog Input Interface	38
5.8	Power Output	38
5.9	IntelliSlot Communication	38
5.10	OC Web Card—SNMP/HTTP Network Interface Card	39
5.10.1	Configuring Baud Rates	40
5.11	Relay Card	42
5.12	MultiPort 4 Card	43

6.0	INSTALLATION DRAWINGS	44
7.0	OPERATION	58
7.1	General Description	58
7.2	Bypass Supplies	58
7.3	Operating Modes	58
8.0	OPERATOR CONTROL AND DISPLAY PANEL	60
8.1	Operator Control Panel	60
8.1.1	Display Panel Layout	60
8.2	Mimic Display Indicators	61
8.3	Control Buttons	62
8.4	Alarm Buzzer	62
8.5	LCD Overview	63
8.6	Navigation Keys	64
8.7	UPS System Information	64
8.8	LCD Menus and Data Items	65
8.9	Language Selection	66
8.10	Current Date and Time	66
8.11	UPS Status Messages	69
8.12	Types of LCD Screens	70
8.12.1	Opening Display	70
8.12.2	Default Screen	70
8.12.3	UPS Help Screen	71
8.12.4	Screen Saver Window	71
8.13	Pop-Up Windows	72
8.13.1	From Bypass to Inverter Mode With Power Interruption	72
8.13.2	From Inverter to Bypass Mode With Interruption	72
8.13.3	System Self-Test	72
8.13.4	Battery Capacity Test Confirmation	72
8.13.5	Battery Self-Test Aborted, Condition Not Met	72
8.13.6	Battery Refresh Charge Aborted, Condition Not Met	72
9.0	OPERATING INSTRUCTIONS	73
9.1	TRX Operating Modes	73
9.1.1	Power Switches	74
9.2	UPS Start Up	75
9.2.1	Start-Up Procedure	75
9.2.2	Verify Switching Between Operation Modes	76
9.3	Switching the UPS from Normal to Maintenance Bypass	77
9.4	Powering Down the UPS	77
9.5	Powering Down the UPS and Maintaining Power to Load	78
9.6	Emergency Shutdown With EPO	79
9.7	Auto Restart	79
9.8	Reset After Shutdown for Emergency Stop (EPO Action) or Other Conditions	79

9.9	Battery Protection	80
9.9.1	Battery Undervoltage Pre-Warning	80
9.9.2	Battery End-of-Discharge (EOD) Protection.	80
9.9.3	Battery Fuse-Blow Warning	80
9.10	Isolating and Integrating One Module in a Multi-Module System	80
9.11	Inserting One Module into a Multi-Module System.	81
9.12	Shutting Down a Multi-Module System Without System Bypass Switch	82
9.13	Shutting Down a Multi-Module System With System Bypass Switch	82
9.14	Commissioning a Parallel System.	83
9.15	Maintenance Bypass Cabinet Operating Procedures.	83
9.15.1	Start Up and Initialization	83
9.15.2	Shutting Down the UPS.	83
9.15.3	Transferring System from UPS to Maintenance Bypass Operation	83
9.15.4	Transfer the System from Maintenance Bypass to UPS Operation	83
9.15.5	Transfer the System from UPS Operation to Maintenance Bypass	83
9.16	Parallel System Start Up.	85
9.17	Replacing Dust Filters	85
10.0	UPS SPECIFICATIONS.	86
10.1	Conformity and Standards.	86
10.2	UPS Environmental	86
10.3	UPS Mechanical Characteristics	86
10.4	UPS Electrical Characteristics	87
10.4.1	Battery Manufacturers and Models	88
10.4.2	Input Rectifier.	88
10.4.3	DC Intermediate Circuit	88
10.4.4	Inverter Output	89
10.4.5	Bypass Input.	89
11.0	SPECIFICATIONS AND TECHNICAL DATA.	90
11.1	Lug Size and Torque Requirements	90
11.2	Cable Lengths: Floor to Connection Point Inside UPS	96
APPENDIX A - UPS STATUS MESSAGES		97

FIGURES

Figure 1	Cabinet arrangement	8
Figure 2	Single module block diagram—dual input configuration	10
Figure 3	Input busbars	11
Figure 4	Battery fuses and connections	11
Figure 5	Ground and neutral busbar connections	12
Figure 6	Monitor board U2	14
Figure 7	Auxiliary terminal block detail (Monitoring Board)	15
Figure 8	Input dry contacts	15
Figure 9	Jumper connection for BCB interface	16
Figure 10	Output dry contacts and EPO wiring for firmware before M170.	17
Figure 11	EPO wiring for firmware M200 or later	18
Figure 12	Battery cabinet—details.	20

Figure 13	Narrow battery cabinet, 27 in. (690mm) - rear view	21
Figure 14	Wide battery cabinet, 57 in. (1488mm) - front view	21
Figure 15	Internal cable wiring from battery cabinet to TRX.	23
Figure 16	Battery tray and supports	23
Figure 17	Single UPS with external Maintenance Bypass Cabinet—typical configuration	25
Figure 18	Maintenance Bypass Cabinet—access plate removed	26
Figure 19	Maintenance Bypass Cabinet wiring access panel	27
Figure 20	Maintenance bypass control wire location.	28
Figure 21	Load Bus Synchronization cable connection	30
Figure 22	1+N system block diagram	32
Figure 23	Connecting '1+N' system parallel control cables.	34
Figure 24	Auxiliary dry contact cables for output breaker in multi-module system	35
Figure 25	Dry contacts, multiple UPS modules with distribution panel	35
Figure 26	Connecting EPO push button.	36
Figure 27	Battery circuit breaker box connections	37
Figure 28	OC Web card display.	41
Figure 29	MultiPort 4 card pin assignment	43
Figure 30	Dimensional view- front and left side views	44
Figure 31	Dimensions continued—top and bottom views	45
Figure 32	Main components—typical unit	45
Figure 33	Cable connections	46
Figure 34	Location of internal batteries	47
Figure 35	Battery connections	48
Figure 36	Battery cabinet interconnection.	49
Figure 37	Maintenance Bypass interconnection	50
Figure 38	TRX 1+1 parallel cabinet interconnections	51
Figure 39	Lineup detail—SlimLine distribution cabinet to TRX	52
Figure 40	Lineup detail—1+N Type A connection to TRX	53
Figure 41	Lineup detail—1+N Type B1 connection to TRX	54
Figure 42	Lineup detail—1+N Type C connection to TRX	55
Figure 43	Suggested placement—single TRX with auxiliary cabinets.	56
Figure 44	Suggested placement, multiple TRX units with auxiliary cabinets.	57
Figure 45	Single module block diagram (dual input configuration)	58
Figure 46	Overview of control panel	60
Figure 47	Detailed view of control panel	60
Figure 48	Mimic display indicators location.	61
Figure 49	Location of control buttons	62
Figure 50	Alarm buzzer location.	62
Figure 51	Sections of the LCD.	63
Figure 52	Menu tree	65
Figure 53	Current status and history log records	69
Figure 54	Opening display.	70
Figure 55	Default screen	70
Figure 56	Help screen	71
Figure 57	Screen saver window.	71
Figure 58	Power switches - 10kVA TRX.	74
Figure 59	Typical configuration for single UPS with external maintenance bypass cabinet	78
Figure 60	Single UPS with external Maintenance Bypass Cabinet—typical configuration	84
Figure 61	Dust filter replacement.	85

TABLES

Table 1	Input dry contacts at X3	15
Table 2	Maintenance bypass cabinet interface	16
Table 3	BCB box interface	16
Table 4	Output dry contact relays	17
Table 5	EPO input contact relays	17
Table 6	EPO input contact relays	18
Table 7	Available battery circuit breaker boxes	36
Table 8	TRX communication options	39
Table 9	Relay Card pin configuration	42
Table 10	Relay card jumper configuration	42
Table 11	Dual-Lite-supplied interconnect wiring	49
Table 12	Dual-Lite-supplied interconnect wiring for Maintenance Bypass Cabinet	50
Table 13	Dual-Lite-supplied interconnect wiring	51
Table 14	Dual-Lite-supplied interconnect wiring—SlimLine distribution cabinet to TRX	52
Table 15	Interconnect wiring—1+N Type A connection to TRX	53
Table 16	Interconnect wiring—1+N Type B1 connection to TRX	54
Table 17	Interconnect wiring—1+N Type C connection to TRX	55
Table 18	Mimic display status indicators	61
Table 19	Control buttons	62
Table 20	Icons for navigation keys	64
Table 21	Description of items in UPS system window	64
Table 22	Descriptions of UPS menus and data window items	67
Table 23	UPS operating modes	73
Table 24	Rotary switch configuration	74
Table 25	Environmental characteristics	86
Table 26	Mechanical characteristics	86
Table 27	UPS terminal	87
Table 28	Approved batteries	88
Table 29	Rectifier input power	88
Table 30	DC intermediate circuit	88
Table 31	Inverter output	89
Table 32	Bypass input	89
Table 33	Torque specifications	90
Table 34	Battery torque rating	90
Table 35	Maintenance bypass cabinet electrical data (single input)	91
Table 36	Maintenance bypass cabinet electrical data (dual input)	92
Table 37	Multi-module bypass cabinet electrical data	93
Table 38	Maintenance bypass cabinet lug sizes	94
Table 39	Battery cabinet physical characteristics	95
Table 40	Maintenance Bypass Cabinet weights	95
Table 41	Maintenance bypass cabinet dimensions	95
Table 42	Multi-module paralleling cabinet dimensions	95
Table 43	Distance to connection points on the TRX UPS	96
Table 44	UPS status messages	97

IMPORTANT SAFETY INSTRUCTIONS

SAVE THESE INSTRUCTIONS

This manual contains important instructions that should be followed during installation of your Dual-Lite Trident® TRX UPS and batteries.

Read this manual thoroughly, paying special attention to the sections that apply to your installation, before working with the UPS. **Retain this manual for use by installing personnel.**



WARNING

Exercise extreme care when handling UPS cabinets to avoid equipment damage or injury to personnel. The UPS module weight ranges from 850 to 1400 lb. (386 to 635kg).

Determine unit weight and locate center of gravity symbols  before handling the UPS. Test lift and balance the cabinet before transporting. Never tilt equipment more than 15 degrees from vertical.

Battery manufacturers supply details of the necessary precautions to be observed when working on, or in the vicinity of, a large bank of battery cells. These precautions should be followed implicitly at all times.

Follow all battery safety precautions when installing, charging or servicing batteries. In addition to the hazard of electric shock, gas produced by batteries can be explosive and sulfuric acid can cause severe burns. When connected, the nominal battery voltage is 288VDC and is potentially lethal.

In case of fire involving electrical equipment, use only carbon dioxide fire extinguishers or those approved for use in fighting electrical fires.

Extreme caution is required when performing maintenance.

Be constantly aware that the UPS system contains high DC as well as AC voltages.

Check for voltage with both AC and DC voltmeters prior to making contact.



WARNING

As with other types of high power equipment, dangerous voltages are present within the UPS and battery enclosure. The risk of contact with these voltages is minimized as the live component parts are housed behind a hinged, lockable door. Further internal safety screens make the equipment protected to IP20 standards.

No risk exists to any personnel when operating the equipment in the normal manner, following the recommended operating procedures.

All equipment maintenance and servicing procedures involve internal access and should be carried out only by trained personnel.



WARNING

High ground leakage current: Ground connection is essential before connecting the input supply.

This equipment must be grounded in accordance with local electrical codes.

Maximum load must not exceed that shown on the UPS rating label.



WARNING

This product contains chemicals known to the state of California to cause cancer, birth defects and/or other reproductive harm. Thoroughly wash hands after installing, handling, cleaning or otherwise touching this product.



CAUTION

This equipment is fitted with RFI suppression filters.

Ground leakage current exceeds 3.5 mA and is less than 1000 mA.

Transient and steady-state ground leakage currents, which may occur when starting the equipment, should be taken into account when selecting instantaneous residual current circuit breakers (RCCBs) or residual current devices (RCDs).

RCCBs must be selected sensitive to DC unidirectional pulses (Class A) and insensitive to transient current pulses.

Note also that the ground leakage currents of the load will be carried by this RCCB or RCD.



WARNING

Under typical operation and with all UPS doors closed, only normal safety precautions are necessary. The area around the UPS system should be kept free of puddles of water, excess moisture and debris.

Special safety precautions are required for procedures involving handling, installation and maintenance of the UPS system and the battery. Observe all safety precautions in this manual before handling or installing the UPS system. Observe all precautions in the Operation and Maintenance Manual, before as well as during performance of all maintenance procedures. Observe all battery safety precautions before working on or near the battery.

This equipment contains several circuits that are energized with high voltage. Only test equipment designed for troubleshooting should be used. This is particularly true for oscilloscopes. Always check with an AC and DC voltmeter to ensure safety before making contact or using tools. Even when the power is turned Off, dangerously high electric charges may exist within the UPS.

All power and control wiring should be installed by a qualified electrician. All power and control wiring must comply with the NEC and applicable local codes.

ONLY qualified service personnel should perform maintenance on the UPS system.

When performing maintenance with any part of the equipment under power, service personnel and test equipment should be standing on rubber mats. The service personnel should wear insulating shoes for isolation from direct contact with the floor (earth ground).

Never work alone, even if all power is removed from the equipment. A second person should be standing by to assist and summon help in case an accident should occur.



CAUTION

This unit complies with the limits for a Class A digital device, pursuant to Part 15 Subpart J of the FCC rules. These limits provide reasonable protection against harmful interference in a commercial environment. This unit generates, uses and radiates radio frequency energy and, if not installed and used in accordance with this instruction manual, may cause harmful interference to radio communications. This unit is not designed for use in a residential area. Operation of this unit in a residential area may cause harmful interference that the user must correct at his own expense.

Battery Cabinet Precautions

The following warning applies to all battery cabinets supplied with UPS systems. Additional warnings and cautions applicable to battery cabinets may be found in **3.0 - Battery Installation**.



WARNING











Internal battery strapping must be verified by manufacturer prior to moving a battery cabinet (after initial installation).

- Battery cabinets contain non-spillable batteries.
- Keep units upright.
- Do not stack.
- Do not tilt.

Failure to heed this warning could result in smoke, fire or electric hazard.

Call 1-800-543-2378 before moving battery cabinets (after initial installation).

GLOSSARY OF SYMBOLS

	Risk of electrical shock
	Indicates caution followed by important instructions
	AC input
	AC output
	Requests the user to consult the manual
	Indicates the unit contains a valve-regulated lead acid battery
	Recycle
	DC voltage
	Equipment grounding conductor
	Bonded to ground
	AC voltage

1.0 INSTALLATION

Dual-Lite's Trident TRX™ Uninterruptible Power Supply system provides continuous, high-quality AC power to your business-critical equipment, such as telecommunications and data processing equipment. The TRX supplies power that is free of the disturbances and variations in voltage and frequency common to utility power, which is subject to brownouts, blackouts, surges and sags.

The TRX utilizes the latest in high-frequency, double-conversion pulse width modulation (PWM) technology and fully digital controls to enhance its reliability and increase the ease of use.

This section describes the TRX's environmental requirements and mechanical considerations that must be taken into account when planning the positioning and cabling of the UPS equipment.

Because every site is unique, this section presents a guide to general procedures and practices that should be observed by the installing engineer, rather than step-by-step installation instructions.



WARNING

Do not apply electrical power to the UPS equipment before the arrival of the commissioning engineer.



WARNING

The UPS equipment should be installed by a qualified engineer in accordance with the information contained in this section.



WARNING

Special care should be taken when working with the batteries associated with this equipment. When connected together, the nominal battery voltage is 288VDC and is potentially lethal.

- Eye protection should be worn to prevent injury from accidental electrical arcs.
- Remove rings, watches and all metal objects.
- Only use tools with insulated handles.
- Wear rubber gloves.

If a battery leaks electrolyte or is otherwise physically damaged, it must be replaced, stored in a container resistant to sulfuric acid and disposed of in accordance with local regulations.

If electrolyte comes into contact with skin, the affected area should be washed immediately with large amounts of water.



NOTE

The TRX UPS can be used in TN utility system.

1.1 External Inspections

1. While the UPS system is still on the truck, inspect the equipment and shipping container(s) for any signs of damage or mishandling. Do not attempt to install the system if damage is apparent. If any damage is noted, file a damage claim with the shipping agency within 24 hours and contact Technical Services at 1-800-543-2378 to inform them of the damage claim and the condition of the equipment.
2. Compare the contents of the shipment with the bill of lading. Report any missing items to the carrier and your local sales representative immediately.

1.2 Internal Inspections

1. Remove any packaging material, then visually examine the UPS and battery equipment for transit damage, both internally and externally. Report any such damage to the shipper and to the manufacturer immediately.
2. Check the nameplate inside the cabinet door to verify that the model number and rating correspond to the ones specified. Record the model number and serial number in the front of this installation manual. This information is necessary should service be required.
3. Check for loose connections or unsecured components in the cabinet.
4. Check for shipping damage to internal components.

1.2.1 Storing for Delayed Installation

If the equipment will not be installed immediately, it must be stored indoors where the humidity is no higher than 90% and the temperature is no higher than 104°F (40°C). The storage area must protect the TRX from excessive moisture (see **10.2 - UPS Environmental**).



CAUTION

If the UPS must remain disconnected from power for more than six (6) months, the battery must be recharged before use. To charge the batteries, the unit must be connected to utility power and started up—the charger operates only while the TRX is operating.



CAUTION

When batteries are installed in the UPS or are cabinet-mounted adjacent to the UPS unit, the battery—not the UPS—dictates the designed maximum ambient temperature.

1.3 Preliminary Checks

1.3.1 Identification

The equipment supplied has an identification tag on the back of the main door listing the type and size of the UPS.

1.4 UPS Location

1.4.1 Positioning the UPS

Choose a location for the UPS that offers:

- Easy connection to inputs, outputs and auxiliary equipment
- Enough space to service the UPS
- Air circulation sufficient to expel heat produced by UPS
- Protection against moisture and excessive humidity
- Protection against dust and other particulate matter
- Compliance with fire prevention regulations and practices
- Operating environment temperature of 74-80°F (23-27°C) for maximum battery efficiency

1.4.2 Environmental Considerations

Before installing the TRX, verify that the UPS room satisfies the environmental conditions stipulated in **10.2 - UPS Environmental**, paying particular attention to the ambient temperature and air exchange system.

The UPS unit should be installed in a cool, dry, clean-air environment with adequate ventilation to keep the ambient temperature within the specified operating range 32°F to 104°F (0°C to 40°C).

For optimal UPS and battery system performance and service life, maintain the operating temperature within the range of 74-80°F, (23-27°C).

The TRX UPS cooled by internal fans. Cooling air enters the unit through the front of the unit and is exhausted out the top. To permit proper air flow and prevent overheating, do NOT block or cover the ventilation openings or blow air down onto the unit. Ventilation clearance above the unit must be a minimum of 24 in. (610mm).

See **Table 26** for details on heat dissipation.

Battery Location

Temperature is a major factor in determining battery life and capacity. Battery manufacturers recommend an operating temperature of 77°F (25°C). Ambient temperatures warmer than this reduce battery life; temperatures below this reduces battery capacity. In a typical installation, battery temperature should be maintained between 74°F and 80°F (23-27°C). Batteries should be placed where there are no main heat sources or air inlets to prevent portions of batteries from being either much warmer or much cooler than other parts of the batteries.

1.4.3 Special Considerations for 1+N Systems

1. Consider the grounding configuration of your system before finalizing module placement. For optimal ground performance, the TRX modules should be close together.
2. For optimal load-sharing performance, the UPS output cables should be approximately the same length, plus or minus 20 percent.
3. Position modules in such a way as to minimize the length of power cables and control wiring between UPS modules and the paralleling cabinet.

1.5 Considerations in Moving the TRX

Ensure that the UPS weight is within the designated surface weight loading (lb./ft² or kg/cm²) of any handling equipment. See **Table 26** for weights of various units.

To move the UPS and optional battery cabinets:

- The TRX may be rolled on its casters when moving the unit a short distance. For longer distances, move the UPS with a forklift or similar equipment to ease the relocation and to reduce vibration.

The optional battery cabinets should be moved with a forklift or similar equipment.



WARNING

Ensure that any equipment that will be used to move the TRX has sufficient lifting capacity. The TRX weight ranges from 850 to 1400 lb. (386 to 635kg). See **Table 26** for details. The UPS presents a tipping hazard. Do not tilt the TRX further than 15 degrees from vertical.

The UPS is fitted with casters—take care to prevent movement when unbolting the equipment from its shipping pallet. Ensure adequate personnel and lifting equipment are available when taking the TRX off its shipping pallet. Do not tilt the unit more than 15 degrees from center.



WARNING

The casters are strong enough for movement across even surfaces only. Casters may fail if they are subjected to shock loading, such as being dropped or rolled over holes in the floor or obstructions. Such failure may cause the unit to tip over, injuring personnel and damaging the equipment.

Care must be taken when maneuvering units fitted with batteries. Keep such moves to a minimum. For further information, see **Battery Cabinet Precautions on page 2**.

Final Position

When the equipment has been finally positioned, ensure that the adjustable stops are set so that the UPS will remain stationary and stable (see **6.0 - Installation Drawings**).

1.6 Mechanical Considerations

The TRX is constructed with a steel frame and removable panels. Top and side panels are secured to the chassis by screws. The doors may be opened for access to power connections bars, auxiliary terminals blocks and power switches.

The UPS comes with an operator control panel, which provides basic operational status and alarm information. The cabinet houses both the power components and the internal batteries. Cooling is provided by internal fans. The unit sits on four casters. Adjustable stops are provided to prevent the UPS from moving once it has been moved to its final position.

1.6.1 Clearances

There are no ventilation grilles on the sides or rear of the UPS. The sides must be accessible during installation. After installation, the unit may be placed with the rear against a wall and optional cabinets on either side.

To enable routine tightening of power terminations within the UPS, make sure there is sufficient clearance in front of the TRX to permit free passage of personnel with the door fully opened.

Leave a minimum of 2 ft. (610mm) between the top of the UPS and the ceiling to permit adequate air circulation above the unit. Dual-Lite recommends against using air conditioning or other systems that blow air onto the top of the unit.

1.6.2 Floor Installation

The diagrams in **6.0 - Installation Drawings** show the location of holes in the base plate for bolting the equipment to the floor. An optional anchoring kit is available. For information, see your local sales representative.

If the equipment is to be placed on a raised floor, it should be mounted on a pedestal that will support the equipment point loading. Refer to the bottom view in **Figure 30** to design this pedestal.

1.6.3 Cable Entry

Cables can enter the TRX from the top or bottom. Cable entry is made possible by removing a metal plate attached to the UPS.

These plates are designed to allow the personnel to punch holes for fitting and securing the conduit. Once the conduit holes are punched, these plates should be reattached to the UPS.

Connecting cables to the TRX may require that the UPS be accessible from the left side to allow personnel to complete the connections and make necessary adjustments. After installation is complete, the TRX may be serviced from the front.



NOTE

When installing the UPS, the customer must provide a disconnect with overcurrent protection at the output of the UPS.

10-30kVA UPS

The 10-30kVA TRX consists of a single cabinet housing the UPS components and the internal battery string.

Optional battery cabinets are available to provide extended run time. Each cabinet houses additional strings of batteries that operate in parallel with the TRX's internal batteries. The cabinets are designed to be bolted to the right side of the UPS (see **Figure 1**). Refer to **3.4 - External Battery Cabinet Installation** for details.

Optional maintenance bypass/transformer cabinets (MBC-T) are available. These cabinets house the components necessary to:

- Provide an external wrap-around maintenance bypass switch for servicing the UPS
- Provide voltage transformation for site or application requirements
- Provide a means for neutral isolation and allow installations for site without a neutral conductor

MBC-T cabinets are designed to be bolted to the left side of the UPS (see **Figure 1**). Refer to **4.5 - Locating the Cabinet**, for further details.

System Composition

A UPS system can comprise a number of equipment cabinets, depending on the individual system design requirements—e.g., UPS cabinet and External Bypass cabinet. In general, all cabinets used will be the same height and are designed to be positioned side-by-side to form an aesthetically appealing equipment suite.

1.6.4 Optional Cabinets

If your TRX installation includes a Maintenance Bypass Cabinet, the TRX must be positioned to allow the Maintenance Bypass Cabinet to be bolted to **left** side of the TRX (see **Figure 1**). Cables from the Maintenance Bypass Cabinet must be brought through the bottom side of the TRX for connection.

The Maintenance Bypass Cabinet must be cabled and bolted to the TRX **before** the UPS and bypass cabinet are moved into their final position. Connect the input wiring to the Maintenance Bypass Cabinet **ONLY** after the units are connected and positioned.

Battery cabinets may be bolted to either side of the TRX, unless used in configurations that include a Maintenance Bypass Cabinet. If used with a Maintenance Bypass Cabinet, battery cabinets must be installed on the right side of the UPS; see **Figure 1** below.

Figure 1 Cabinet arrangement

ALL UNITS VIEWED FROM ABOVE

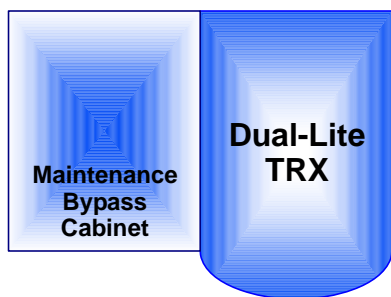

TRX connected only to MBC
(MBC must be on left side of the TRX)

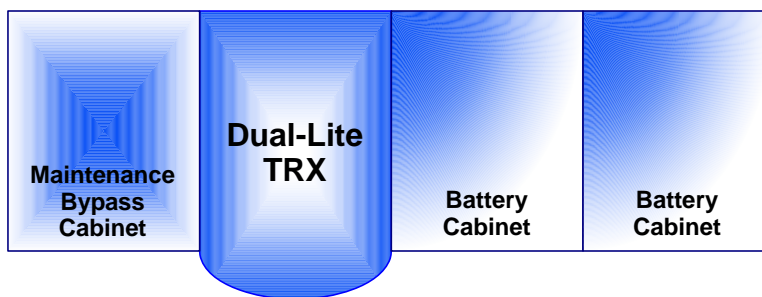

TRX connected to Maintenance Bypass Cabinet and Battery Cabinets
(MBC must be on left side of the TRX)
(Battery Cabinets must be on the right side of the TRX in this configuration)

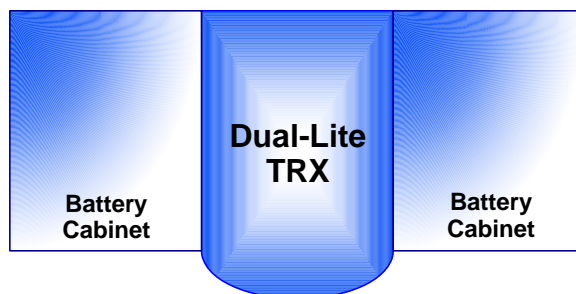

TRX connected to Battery Cabinets
(Battery Cabinets may be on either side of the TRX)

2.0 ELECTRICAL CONNECTIONS

The UPS requires both power and control cabling once it has been mechanically installed. All control cables must run separate from power cables in metal conduits or metal ducts that are electrically bonded to the metalwork of the cabinets to which they are connected.



WARNING

Before connecting input power to the TRX, ensure that you are aware of the location and operation of the overcurrent protection devices that connect the UPS input/bypass supply to the power distribution panel.

De-energize and lockout or tagout all incoming high- and low-voltage power circuits before installing cables or making any electrical connections.

2.1 Power Cabling

2.1.1 Cable Rating

The main factors affecting the choice and size of cable are voltage, current (also taking into account overcurrent), room temperature and conditions of installation of the cable.

The power cables of the system must be sized with respect to the following description:

- **UPS input cables** - The UPS input cables must be sized for the maximum input current, including the maximum battery recharge current, given in **Table 27**, with respect to the unit rating and the input AC voltage.
- **UPS bypass and output cables** - The bypass and output cables must be sized for the nominal output current, given in **Table 27**, with respect to the unit rating and the output AC voltage.
- **Battery cables** - Each UPS unit has its own internal batteries factory-wired. If connecting an external battery cabinet, the battery cables must be sized for the battery discharge current at the end-of-discharge voltage, as given in **Table 27**, with respect to the unit rating.



NOTE

Table 27 gives nominal currents for determining the size of UPS power cables. Other important factors to consider include cable route length and coordination with protective devices.

The power cables can be sized to suit the UPS unit rating according to **Table 27**.

Lug Size and Torque Requirements

Refer to **Table 33** for lug size and torque requirements.

2.1.2 UPS Input Configuration

Figure 2 illustrates the TRX in a split bypass (dual-input) configuration. In this configuration the Static Bypass and the Maintenance Bypass lines are supplied from a separate feed from the Main input. Both sources must be protected externally with properly sized protective devices. By default, the unit ships with internal links installed between the Bypass input and Main input (single-input configuration). To wire the unit as a dual input UPS, remove the links and wire the bypass to the input bus bars, then wire the Main input directly to CB1 (see **Figure 3**).

Figure 2 Single module block diagram—dual input configuration

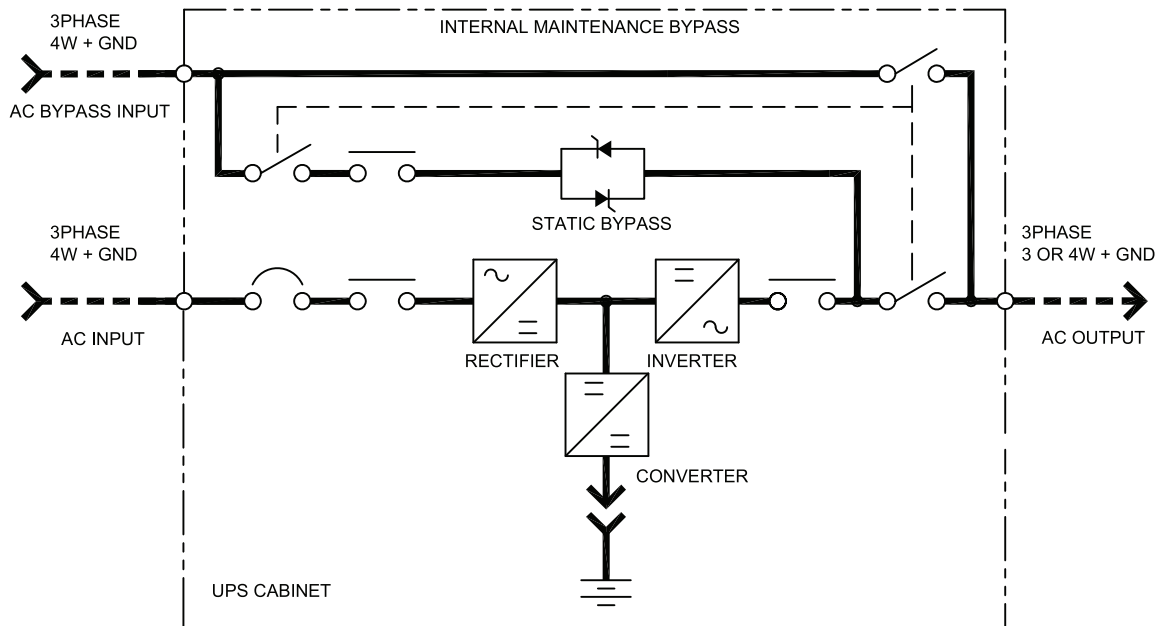

2.1.3 Cabling Guidelines

The following are guidelines only and are superseded by local regulations and codes of practice where applicable. Use wiring rated at 75°C or greater.

1. Take special care when determining the size of the neutral cable, as current circulating on the neutral cable may be greater than nominal current in the case of non-linear loads. Refer to the values in **10.4 - UPS Electrical Characteristics**.
2. The ground conductor should be sized according to such factors as the fault rating, cable lengths and type of protection. The ground cable connecting the UPS to the main ground system must follow the most direct route possible. Control wiring and power wiring must be run in separate conduit. Output and input cables must be run in separate conduit.
3. Consider using paralleled smaller cables for heavy currents—this can ease installation.
4. When sizing battery cables, a maximum voltage drop of 4VDC is permissible at the current ratings in **Table 27**. For terminal connection sizing, see **Table 27**.
5. In most installations, especially parallel multi-module systems, the load equipment is connected to a distribution network of individually protected busbars fed by the UPS output, rather than connected directly to the UPS itself. When this is the case, the UPS output cables can be rated to suit the individual distribution network demands rather than being fully load-rated.



NOTE

If more load is added to the distribution panel, the unit's cabling must be resized.

6. When laying power cables, do not form coils; this will help avoid increasing formation of electromagnetic interference.



NOTE

Left-side access may be required when making power connections. Cable connections should be made before a cabinet is attached to the left side of the TRX or before the UPS is placed where another obstruction, such as a wall, is against the TRX's the left side.

2.1.4 Cable Connections

The rectifier input, bypass and output are easily accessible from the left side of the unit for installation. All require lug type terminations. They are connected to busbars on the left side of the TRX and below the switch, as shown in **Figure 3**. These busbars are accessible when the left side panel is removed. Busbars to connect external batteries are accessible from the front of the UPS.



NOTE

External battery connection access requires removal of a protective panel on the lower front of the UPS to the left of the bottom two battery shelves.

Figure 3 Input busbars

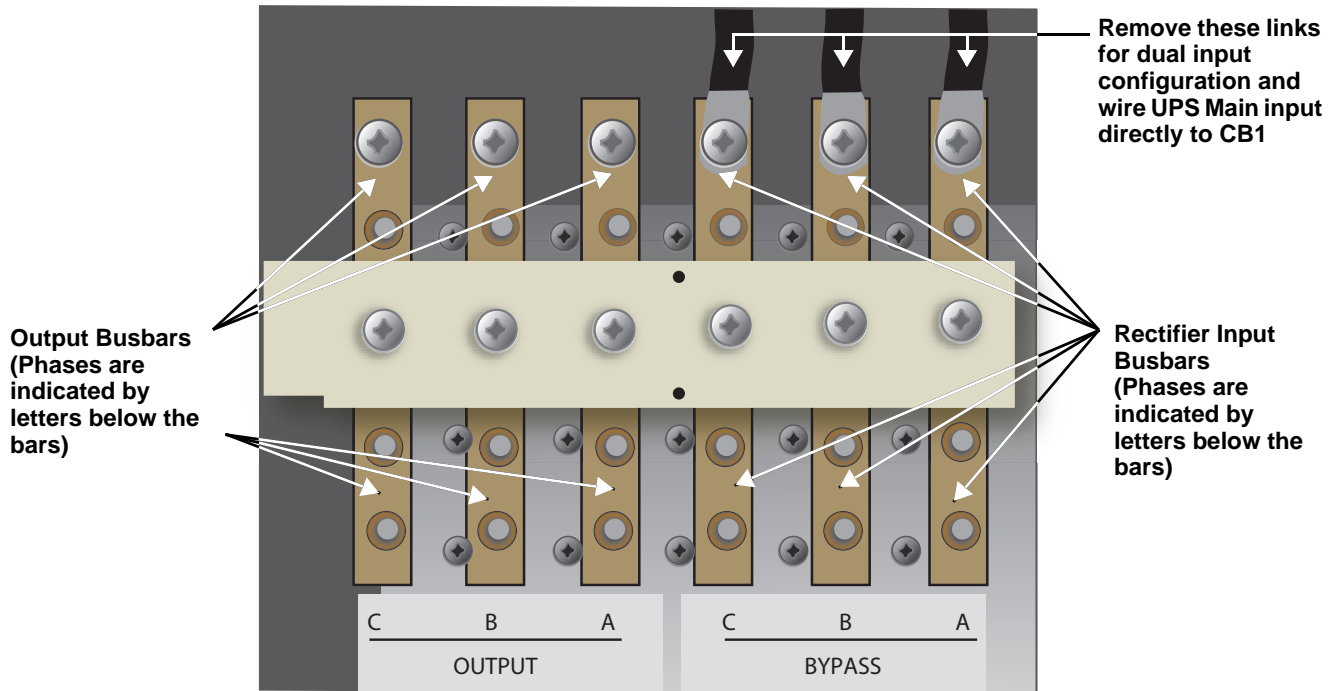

The internal batteries are connected with Anderson connectors inside the battery compartment. The batteries are connected to fuses to protect the TRX and connected equipment (see **Figure 4**).

Figure 4 Battery fuses and connections

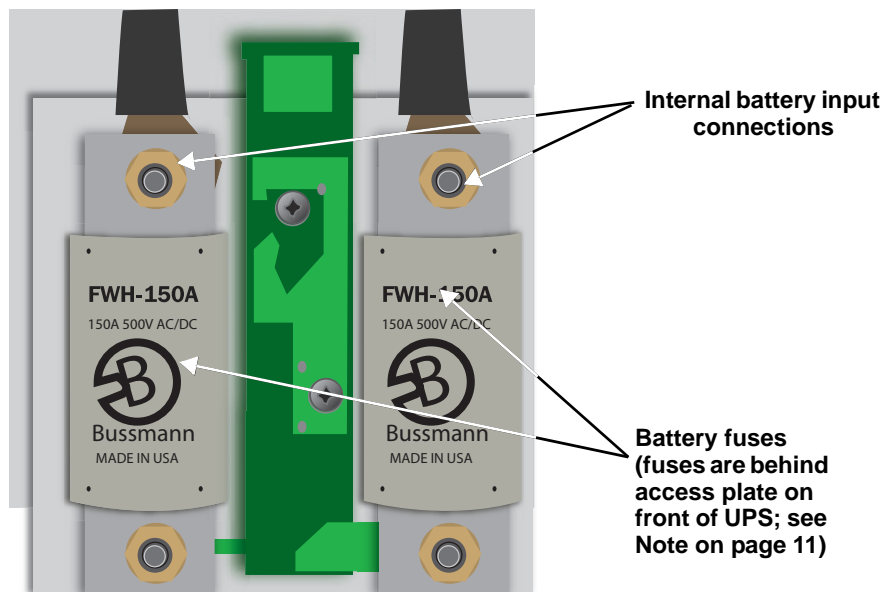

2.1.5 Safety Ground

The safety ground busbar is located below the neutral input and output busbars as shown in **Figure 5** below. The safety ground cable must be connected to the ground busbar and bonded to each cabinet in the system.

All cabinets and cable conduit should be grounded in accordance with local regulations.



WARNING

Failure to follow proper grounding procedures can result in electric shock hazard to personnel or the risk of fire, should a ground fault occur.



NOTE

Proper grounding significantly reduces problems in systems caused by electromagnetic interference.



NOTE

The ground and neutral busbars are easily accessible when the left protective cover plate is removed. Cable connections should be made before a cabinet is attached to the left side of the TRX or before the UPS is placed where another obstruction, such as a wall, is against the TRX's the left side.

Figure 5 Ground and neutral busbar connections

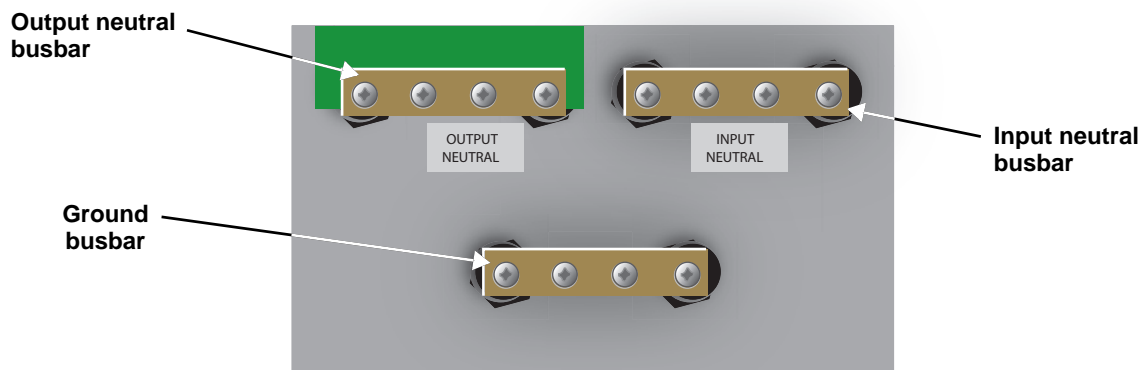

2.1.6 Protective Devices

For safety, it is necessary to install circuit breakers in the input AC supply and external battery battery cabinets, external to the UPS system. Given that every installation has its own characteristics, this section provides guidelines for qualified installation engineers with knowledge of operating practices, regulatory standards and the equipment to be installed.

UPS Rectifier and Bypass Input Supply

- **Protection from excessive overcurrents and short circuits in power supply input**

External overcurrent protection for the AC output circuit is to be provided. See **10.4 - UPS Electrical Characteristics** and **Table 29** for overload capacity.

High-speed fuses and SCRs are used for internal battery circuit overcurrent protection. When an external battery supply is used, overcurrent protection for the battery circuit is to be provided by the customer.

- **Dual Input**

When wiring the UPS with dual inputs, the Rectifier input and the Bypass input must be protected separately. Size the breakers according to the input currents shown in **Table 27**.

System Output

When using an external distribution panel for load distribution, the output neutral and input neutral must be separated at the input to the UPS.

2.1.7 Cabling Procedure



CAUTION

The operations described in this section must be performed by authorized electricians or qualified technical personnel. If you have any difficulties, contact your local sales representative or Technical Services.



NOTE

Hydraulic pressure pliers, combinative tools and piston ring pliers should be used to connect AC wiring.

Once the equipment has been positioned and secured for operation, and the battery and ground collars have been connected (see **2.1.4 - Cable Connections**), connect the power cables as described below. (Study the reference drawing in **6.0 - Installation Drawings**.)

1. Verify that all incoming high and low voltage power circuits are de-energized and locked out or tagged out before installing cables or making any electrical connections.
2. Remove the left side panel to gain easier access to the connections busbars.
3. Connect the safety ground and any easier bonding ground bus cables to the copper ground busbar located on the bottom of the equipment below the power connections. All cabinets in the UPS system must be connected to the user's ground connection.



NOTE

The grounding and neutral bonding arrangement must comply with the National Electrical Code and all applicable local codes.

4. Identify and make power connections with incoming cables according to **Steps 5** through **11**.

Common Input Connections

5. For common bypass and rectifier inputs, connect the AC input supply cables between the power distribution panel and the UPS input busbars (A-B-C terminals) and tighten the connections to 44 lb-in. (5 N-m) using the M6 bolt provided.
6. The input neutral cable must be connected to the input neutral busbar (N). See **Figure 5**.

Dual Input Connections

7. For bypass connect the AC input supply cables between the power distribution panel and the UPS input busbars (A-B-C terminals) and tighten the connections to 44 lb-in. (5 N-m) using the M6 bolt provided.
8. For Rectifier Input connect AC input supply cables between the power distribution panel and the UPS input circuit breaker (A-B-C terminals)
9. The bypass and rectifier input neutral cables must be connected to the input neutral busbar (N). See **Figure 5**.



NOTE

*Both the rectifier and bypass feeds **MUST** come from the same utility source, except if the UPS system includes either a configuration F or P external maintenance bypass cabinet.*

Output System Connections—Ensure Correct Phase Rotation

10. Connect the system output cables between the UPS output busbars (A-B-C N terminals) and the critical load and tighten the connections to 44 lb-in. (5 N-m) (M6 bolt).



WARNING

If the load equipment will not be ready to accept power on the arrival of the commissioning engineer, then ensure that the system output cables are safely isolated.

Internal UPS Battery Connections

The UPS internal batteries will be connected at the factory, EXCEPT the Anderson connections between the shelves and to the fuses.



WARNING

The DC bus is live when this internal battery connection is made. This connection is to be performed ONLY by Technical Services at startup.

Observe the battery cable polarity. Be sure that the battery connector is made with the correct polarity.

11. Refit all protective covers removed for cable installation

2.2 Control Cables

2.2.1 Monitor Board Features

Based on your site's specific needs, the UPS may require auxiliary connections to manage the battery system (external battery circuit breaker, battery temperature sensor), communicate with a personal computer or provide alarm signaling to external devices or for Remote Emergency Power Off (REPO). The monitor board, arranged for this purpose, is located on the rear of the operator access door. The main features are:

- Input and Output dry contacts signal (one pair of contacts of relay)
- Emergency Power Off control (EPO)
- Environmental parameter input interface
- User communication (for data setting and user background monitor)
- IntelliSlot[®] interface
- Modem interface
- Temperature detect interface

Figure 6 shows the relationship and connection between the monitoring (U2) board and other boards in the UPS.

Figure 6 Monitor board U2

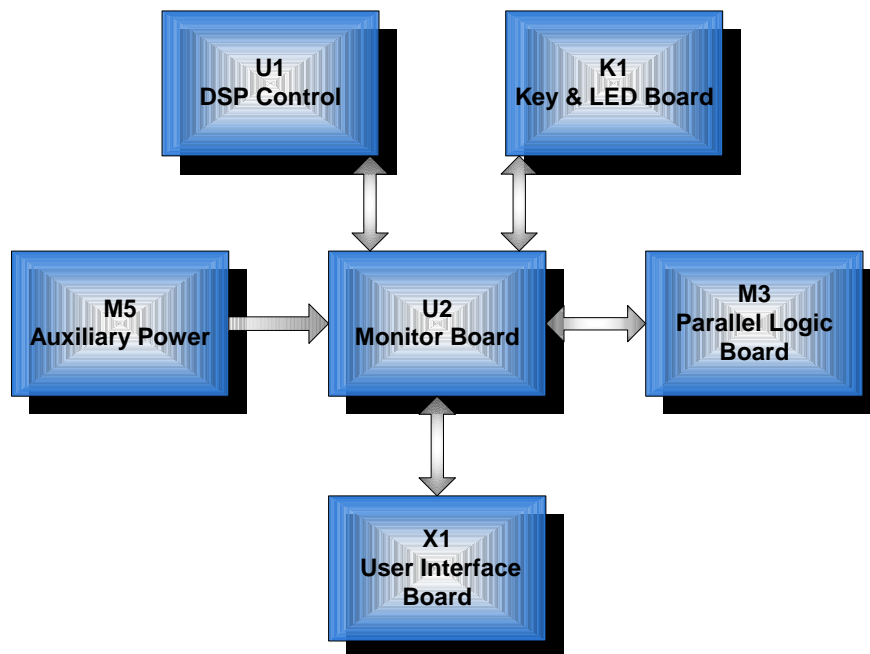
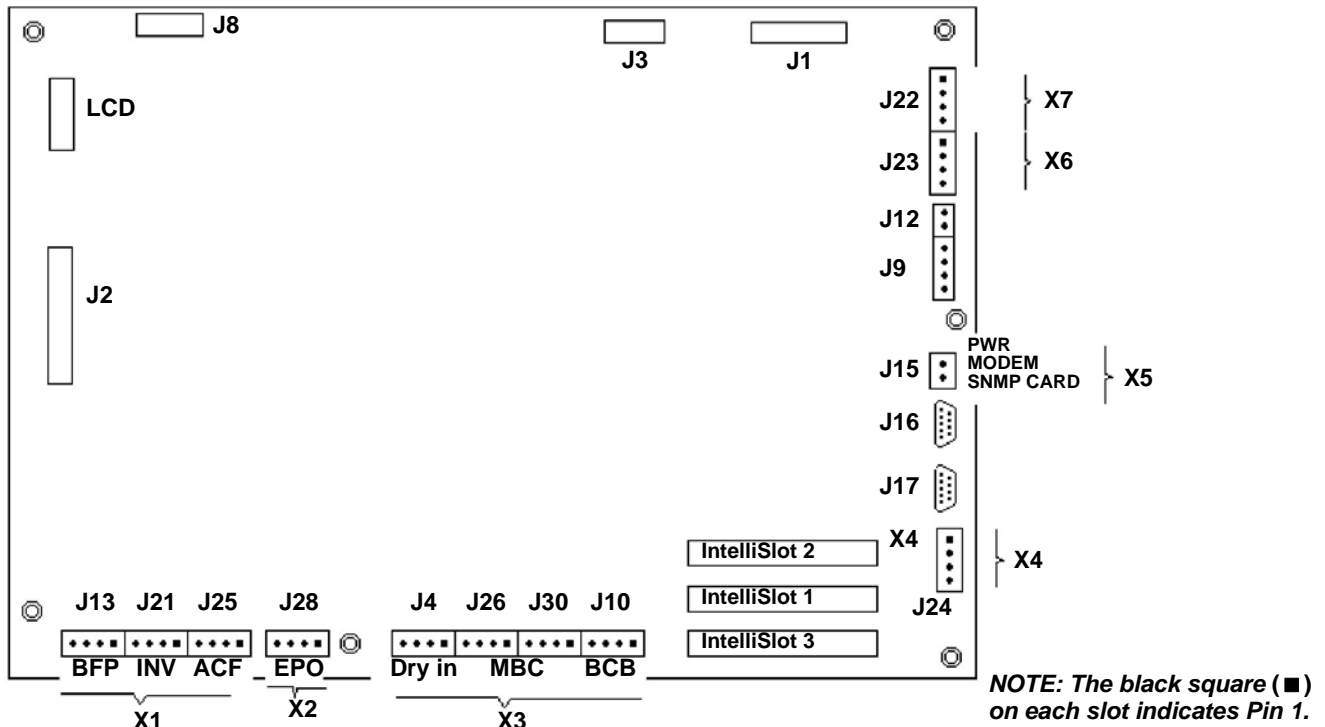

Figure 7 Auxiliary terminal block detail (Monitoring Board)



2.3 Dry Contacts

The UPS provides input dry contacts and output dry contacts.

2.3.1 Input Dry Contacts

There are several input dry contacts at the X3 slot.

Figure 8 Input dry contacts

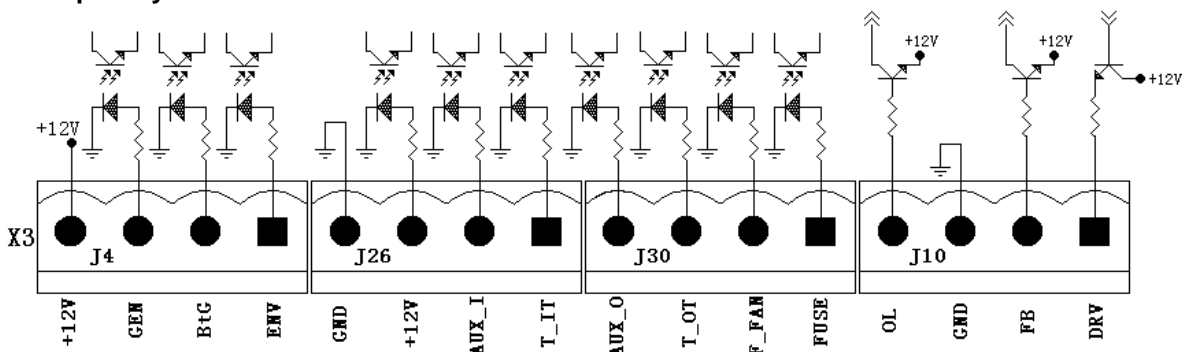

NOTE: The black square (■) on each slot indicates Pin 1.

Table 1 Input dry contacts at X3

Position	Name	Description
J4.1	ENV ³	Battery Room Alarm (N.C.)
J4.2	BtG	Battery Ground Fault Detection (N.C.)
J4.3	GEN ^{1,2}	Generator Join Detection (N.O.)
J4.4	+12V	+12V Power

1 - Must be configured by configuration software before becoming active.

2 - When activated, the charger current can be limited, via software, to a percentage of the full charger current (0-100%).

3 - Activating this feature turns the battery charger off.

2.3.2 Maintenance Bypass Cabinet Interface

J26 and J30 are the MBC interface.

Table 2 Maintenance bypass cabinet interface

Position	Name	Description
J26.1	T_IT ¹	Input transformer over temperature (N.C.)
J26.2	AUX_I	Reserved
J26.3	+12V	+12V Power
J26.4	GND	Power Ground
J30.1	FUSE	Reserved
J30.2	F_FAN	Fan Fail Alarm (N.C.)
J30.3	T_OT ¹	Output Transformer Overtemperature (N.C.)
J30.4	AUX_O	Reserved

1 - Must be configured by software before becoming active



NOTE

All auxiliary cables of terminal must be double-insulated. Wire should be 20-16AWG stranded for maximum runs between 82 and 197 feet (25-60m), respectively.

2.3.3 BCB Box Interface

J10 is the BCB box interface.

Table 3 BCB box interface

Position	Name	Description
J10.1	DRV	BCB Driver Signal - Reserved
J10.2	FB	BCB Contact State
J10.3	GND	Power Ground
J10.4	OL	BCB On-Line - Input - This pin will become active when BCB interface is connected. (N.O.)



NOTE

All auxiliary cables of terminal must be double-insulated. Wire should be 20-16AWG stranded for maximum runs between 82 and 197 feet (25-60m), respectively.



NOTE

If BCB interface is connected, a jumper needs to be added between Pin 3 and Pin 4.

Figure 9 Jumper connection for BCB interface

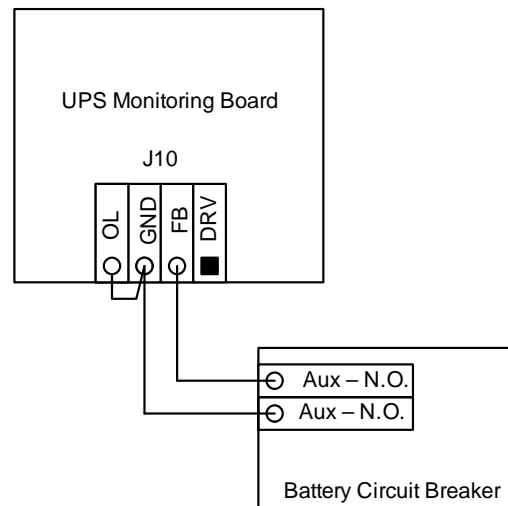

2.3.4 Output Dry Contacts

There are three output dry contact relays at the X1 slot (see **Figure 10** and **Table 4**).

Figure 10 Output dry contacts and EPO wiring for firmware before M170

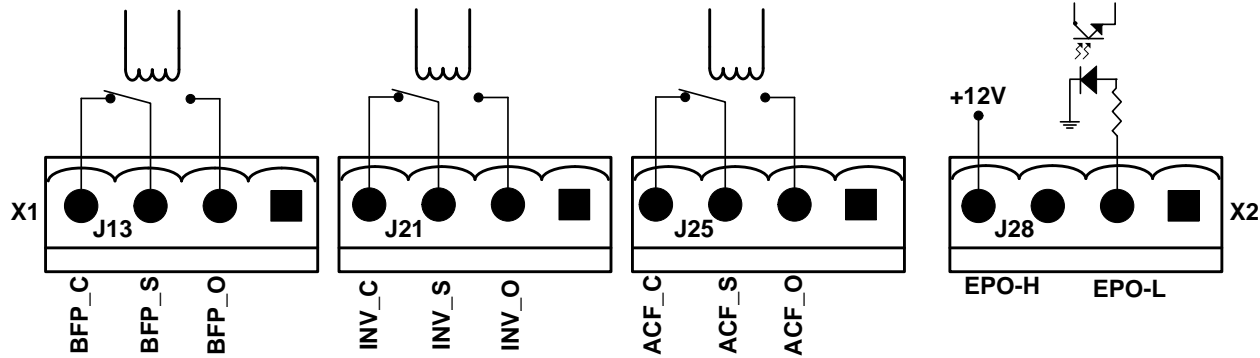

Table 4 Output dry contact relays

Position	Name	Description
J13.2	BFP_O	Bypass feedback protection relay. Normally open. Closed when bypass SCR is shorted.
J13.3	BFP_S	Bypass feedback protection relay center
J13.4	BFP_C	Bypass feedback protection relay. Normally closed. Open when bypass SCR is shorted.
J21.2	INV_O	Inverter mode relay. Normally open. Closed when UPS is in inverter mode.
J21.3	INV_S	Inverter mode relay center
J21.4	INV_C	Inverter mode relay. Normally closed. Open when UPS is in inverter mode.
J25.2	ACF_O	Main input fault relay. Normally open. Closed when main input is in fault.
J25.3	ACF_S	Main input fault relay center
J25.4	ACF_C	Main input fault relay. Normally closed. Open when main input is in fault.



NOTE

All auxiliary cables of terminal must be double-insulated. Wire should be 20-16AWG stranded for maximum runs between 82 and 197 feet (25-60m), respectively.

2.3.5 EPO Input—Optional

Firmware Before M200

The UPS has an Emergency Power Off (EPO) function that operates by a button on the control panel or by a remote contact provided by the user. The EPO button is under a hinged, clear plastic shield.

The X2 slot, shown in **Figure 10**, is the remote EPO input interface. It is active when shorted from EPO-L to EPO-H.

If an external Emergency Stop facility is required, it is connected terminals EPO-L to EPO-H of the auxiliary terminal block (X2). It also is connected to the Normally Open remote stop switch between these two terminals using shielded cable (see **Figure 10** and **Table 5**). If this function is not used, terminals EPO-L to EPO-H must be opened.

Table 5 EPO input contact relays

Position	Name	Description
J28.2	EPO_L	Emergency Power Off Low
J28.4	EPO_H	Emergency Power Off High



NOTE

The Emergency Stop action within the UPS shuts down the rectifier, inverter and static bypass. It does not internally disconnect the input power supply.

To disconnect ALL power to the UPS, open the upstream feeder breaker(s) when the remote EPO is activated.

Firmware M200 or Later

The UPS has an Emergency Power Off (EPO) function operated by a button on the control panel or by a remote contact provided by the user. The EPO button is under a hinged, clear plastic shield.

The X2 slot, shown in **Figure 11**, is the remote EPO input interface. The EPO has a NO/NC contact point becomes active when shorting terminals X2: 3 and 4 or open terminal connection X2: 2 and 1.

If an external Emergency Stop facility is required, it is connected terminals X2: 1&2 or X2: 3 and 4 of the auxiliary terminal block (X2). It also is connected to the Normally Open or Normally Closed remote stop switch between these two terminals using shielded cable (see **Figure 11** and **Table 6**). If this function is not used, terminals X2: 3 and 4 must be opened and X2: 1 and 2 must be closed.

Figure 11 EPO wiring for firmware M200 or later

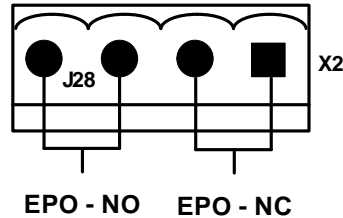

Table 6 EPO input contact relays

Position	Name	Description
J28.1	EPO_NC	EPO Activated when opened to J28.2
J28.2	EPO_NC	EPO Activated when opened to J28.1
J28.3	EPO_NO	EPO Activated when shorted to J28.4
J28.4	EPO_NO	EPO Activated when shorted to J28.3



NOTE

The Emergency Stop action within the UPS shuts down the rectifier, inverter and static bypass. It does not internally disconnect the input power supply. To disconnect ALL power to the UPS, open the upstream feeder breaker(s) when the remote EPO is activated.



NOTE

Normally Closed EPO – X2: 1,2, these terminals are supplied factory-linked on the monitor board and must remain installed if using NC contacts.



NOTE

All auxiliary cables of terminal must be double-insulated. Wire should be 20-16AWG stranded for maximum runs between 82 and 197 feet (25-60m), respectively.

3.0 BATTERY INSTALLATION

3.1 Introduction

Dual-Lite recommends that the batteries in external cabinets match the internal batteries in the TRX in manufacturer and type.

If using multiple sets of batteries connected in parallel to provide the required battery backup run times, fit each set with an isolating device to permit working on one of the battery sets while leaving the others in service and providing backup protection.

When replacing batteries, replace with the same manufacturer and type, or equivalent. See your sales representative for a list of approved batteries.

**NOTE**

The TRX, as shipped, has 24 12-volt batteries installed internally in each unit.

3.2 Safety

Special care should be taken when working with the batteries associated with the TRX system equipment. When all batteries are connected together, the battery terminal voltage may exceed 324V and is **POTENTIALLY LETHAL**.

**WARNING**

The TRX's internal batteries are connected and energized even if the UPS is turned Off. To minimize the risk of injury, a qualified service person should disconnect internal batteries before any maintenance is performed on the unit.

The center of the battery is connected to the neutral of the UPS and is grounded.

A battery can present a risk of electrical shock and high short circuit current. The following precautions should be observed when working on batteries:

- Remove watches, rings and other metal objects.
- Use tools with insulated handles.
- Wear rubber gloves and boots.
- Do not lay tools or metal parts on top of batteries.
- Disconnect charging source prior to connecting or disconnecting battery terminals.

3.3 UPS Batteries

The TRX's internal batteries are fully charged before the unit is shipped. During storage and transportation, some charge is lost. All batteries should be recharged before use. The battery charger works only when the TRX is connected to input power and turned On.

**NOTE**

Full safety instructions concerning the use and maintenance of UPS batteries are provided in the appropriate battery manufacturer's manuals, available on the manufacturer's Web site.

The battery safety information contained in this section relates to key considerations that must be taken into account during the installation design process and might affect the design outcome, depending on your installation.

3.4 External Battery Cabinet Installation

3.4.1 Matching Battery Cabinets

Two sizes of optional battery cabinets are available. Refer to **Figures 13** and **14**. The same model battery cabinet may be installed in parallel in multiple cabinet strings for additional capacity. Battery run time depends on the cabinet model, the number of cabinets and the load on the UPS.

Handling—The battery cabinet has casters to facilitate movement over short distances. The bottoms of the battery cabinets are reinforced to permit movement by forklift over longer distances.

Inspection—Remove all panels and visually inspect the batteries, bus connections, and cabinet for any damage. Exercise caution; voltage is present within the battery cabinet even before installation. If there are signs of damage, do not proceed. Call Technical Services at 1-800-542-2378.

Storage—The batteries can be stored for up to six months without appreciable deterioration. If planning to store a battery cabinet for longer than six months or at temperatures higher than 77°F (25°C), contact Technical Services for recommended precautions.

The following notes, in conjunction with the diagrams (**Figure 13** through **12**), illustrate the broad principles to be followed when fitting and connecting the majority of battery cabinet installations.



CAUTION

Any battery system should be installed by qualified personnel.

When installing an external battery cabinet that is NOT a Dual-Lite TRX battery cabinet, the customer must provide overcurrent protection. See **Table 27** for sizing of protection devices.



NOTE

*When using an external battery supply that is not provided with the UPS, please make reference to the battery manufacturer's installation manual for battery installation and maintenance instructions, available on the manufacturer's Web site. When replacing batteries, Dual-Lite recommends that the batteries in external cabinets be the same type used internally in the TRX. See **Table 28** for a list of batteries that are approved for use with this product.*

3.4.2 Connecting the Batteries

If the TRX battery cabinets are installed on a raised floor, the battery power cables and circuit breaker control cables may be routed to the UPS cabinet via the floor of the cabinet (bottom entry).

If the TRX battery cabinets are installed adjacent to one another on a solid floor, these cables may be passed between the cabinets through lifting slots in the lower sides of the cabinets.

Intertray connections must be made before the battery cabinet may be used.

Figure 12 Battery cabinet—details

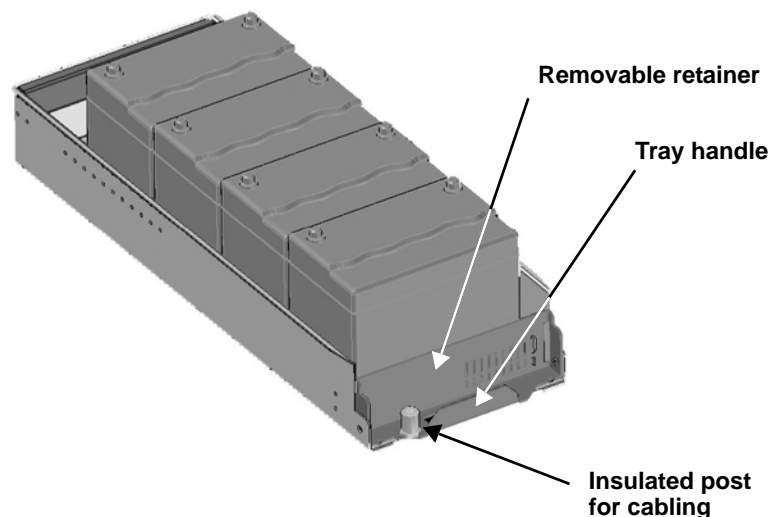

Figure 13 Narrow battery cabinet, 27 in. (690mm) - rear view

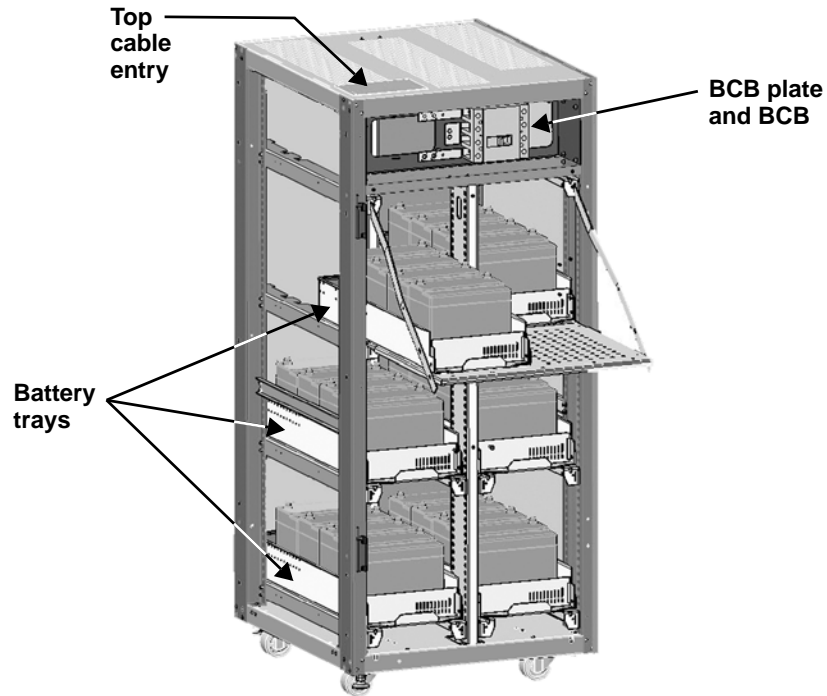
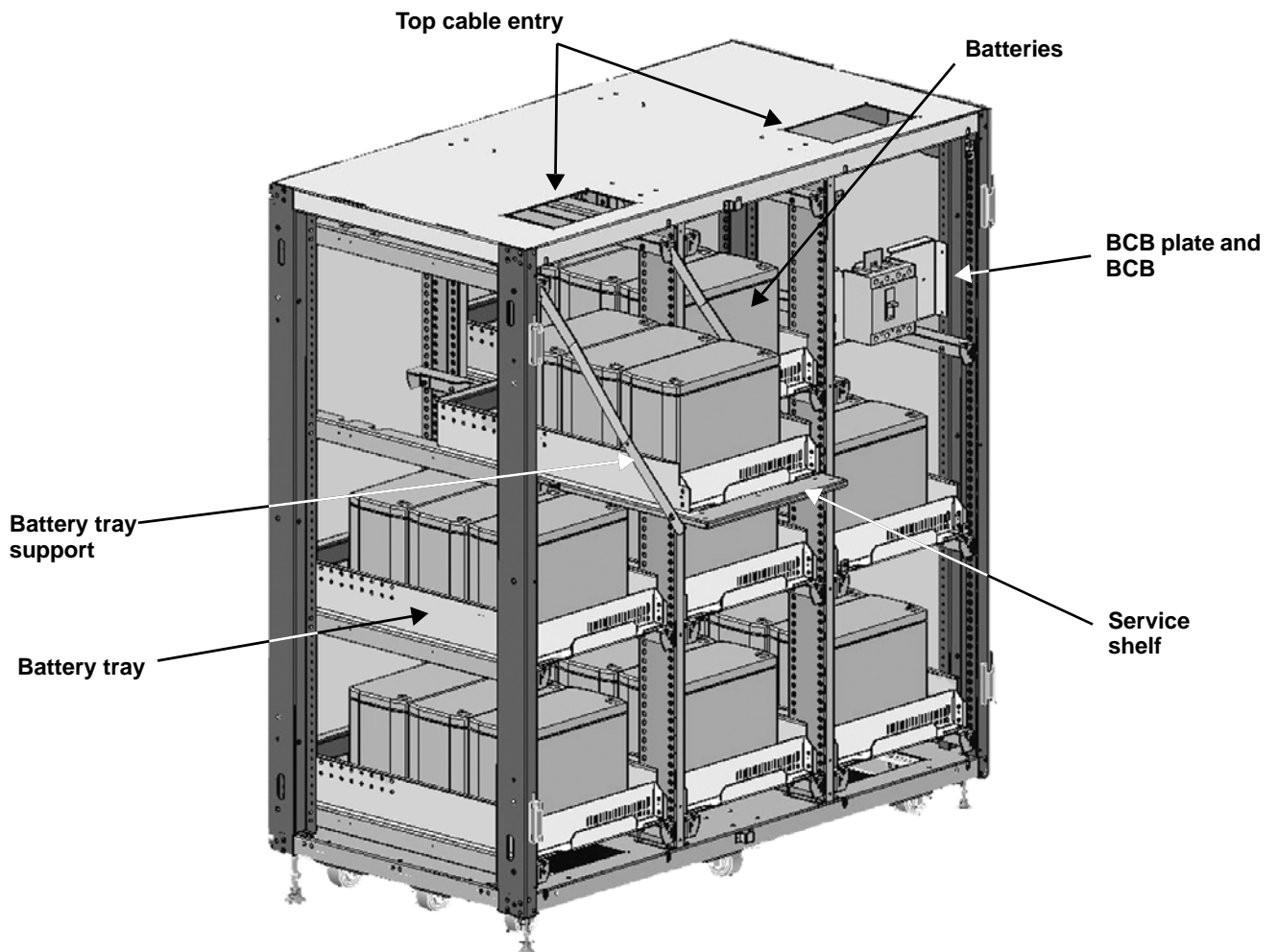

Figure 14 Wide battery cabinet, 57 in. (1488mm) - front view



3.4.3 Installation Considerations

Position—Dual-Lite battery cabinets come in versions specific to either the left or right side of the UPS. Control wires and power cables are cut to different lengths for the different versions. If the system includes a matching maintenance bypass cabinet (MBC), the MBC should be mounted to the left of the UPS (nearest the busbars) and the battery cabinet(s) should be installed to the right of the UPS. Otherwise, left-side placement of the battery cabinet is preferable.

The battery cabinet(s) are designed to be located conveniently next to each UPS module, and are also available in stand-alone configurations with painted side panels. The front access design eliminates side and rear service clearance requirements. Refer to **Table 39** for battery cabinet dimensions and weights.

Bolt-On Cabinets—Matching battery cabinets are designed to bolt onto the side of the UPS module cabinet. Use bolts that ship with each unit to connect cabinet frames at posts, two places in the front and two places in the rear.

Service Clearance—Allow front access to the battery cabinet at all times for maintenance and servicing. Electrical codes require that the battery cabinet be installed with no less than 3 feet (1m) of clearance at the front of the cabinet when operating. Side and rear panels do not require service clearance.

Cables—Cables may be run between the cabinets through cutouts in the top of the cabinet, eliminating the need for external conduit runs. Route cables before moving cabinets into final position for bolting together. No top or bottom entry cables are required, except for remotely located cabinets which require conduits. Refer to **Figure 15**.

Software—To allow the UPS to accurately display the battery run time, the number of battery cabinets must be noted when performing initial startup and setup using the configuration software. This is to be performed by the Technical Services customer engineer when commissioning the unit.

Casters and Adjustable Stops—The adjustable stops are not designed to bear the full weight of the cabinet. Lower the stops until they are finger-tight in contact with the floor. Then tighten a small amount with a wrench (less than two turns) to give a good friction fit. When mounting the battery cabinet on seismic stands, ensure that the casters are bearing the weight of the cabinet.

Battery Support Tray—Be sure to connect the battery tray support to the front of the cabinet before sliding a battery tray out for connection or service. Without the support, the battery tray may fall out of the cabinet. See **Figure 16** for details.

Figure 15 Internal cable wiring from battery cabinet to TRX

Power cables from output power switch

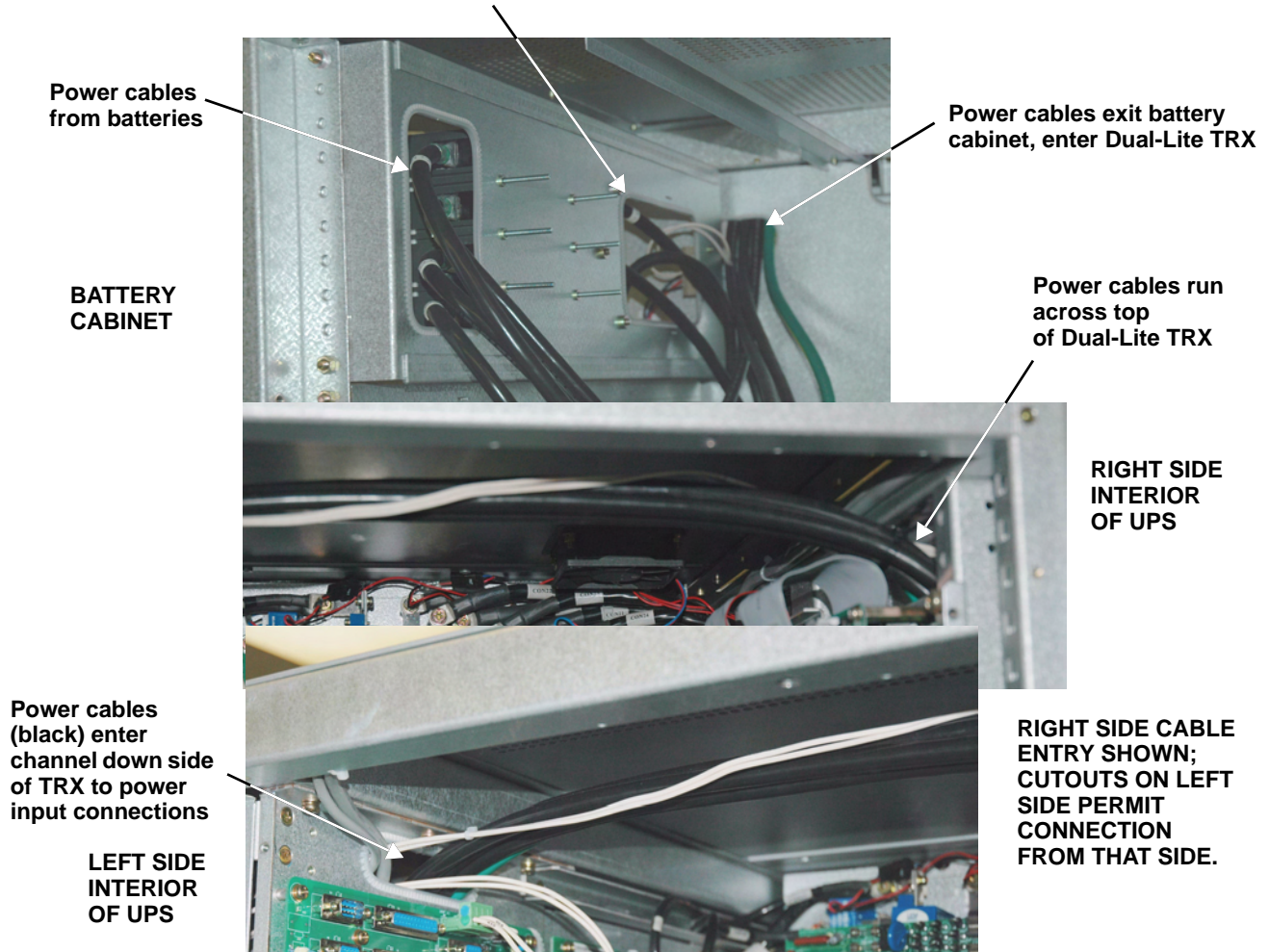
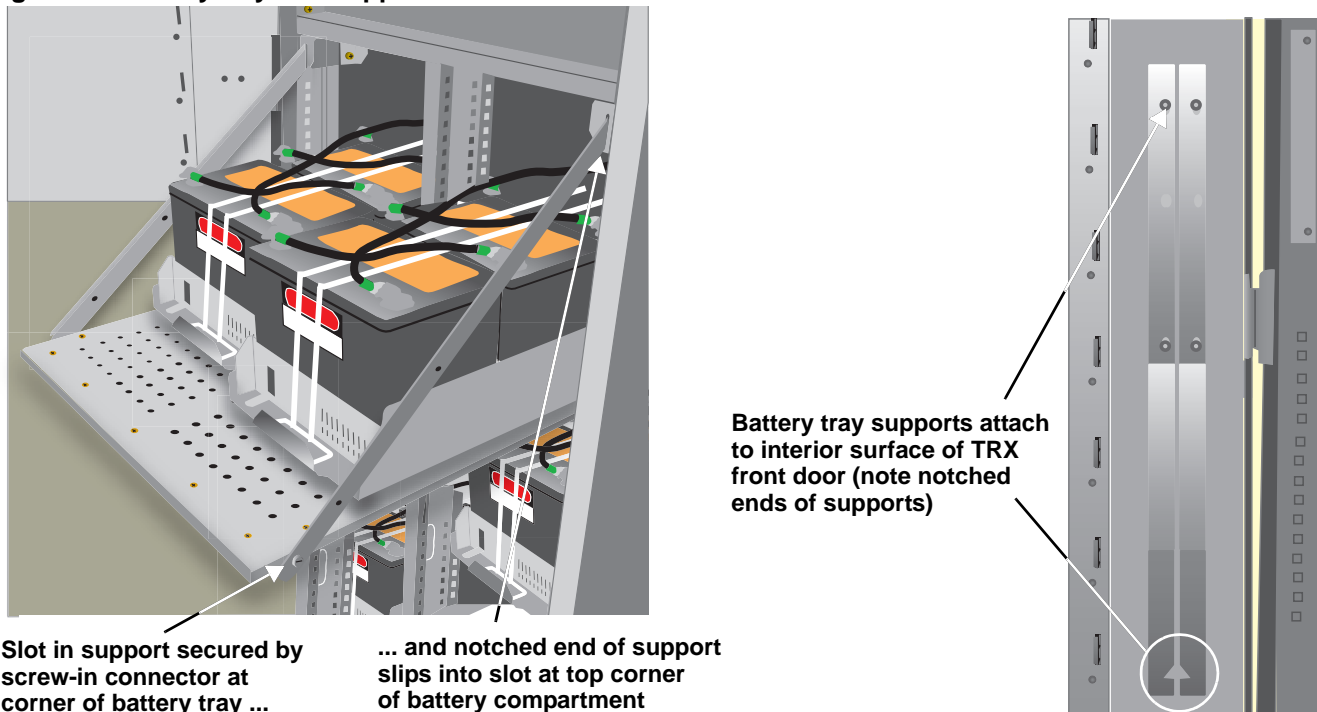

Figure 16 Battery tray and supports



3.4.4 Connecting the Battery Cabinet to the UPS

After the battery cabinet equipment has been positioned and secured for operation and the batteries have been connected, connect the power cables as described below. (See **Figure 36**.)

1. Verify that all incoming high and low voltage power circuits are de-energized and locked out or tagged out before installing cables or making any electrical connections.
2. Remove the UPS left side panel to gain access to the equipment ground busbar.
3. Remove the external battery terminal block plate on the lower left side of the UPS behind the front door.
4. Remove the battery cabinet front panel to gain access to the connection bars.
5. Connect the safety ground and any necessary bonding ground cables to the copper ground busbar. (example: UPS located on the bottom of the equipment below the power connections).

All cabinets in the UPS system must be connected to the user's ground connection.



NOTE

The grounding and neutral bonding arrangement must be in accordance with the National Electrical Code and all applicable local codes.

6. Connect the system battery cables from the UPS battery terminals (+ N -) to battery cabinet BCB (+ N -) as shown in **Figure 36**. Be sure that the battery connections are made with the right polarity, and tighten the connections to 44 lb-in. (5 N-m) (M6 Bolt). Do not close the battery circuit breaker before the equipment has been commissioned.
7. Connect supplied auxiliary control cable to pins J10.2 and J10.3 on the U2 monitoring board (see **2.3 - Dry Contacts**). Add a jumper wire between J10.3 and J10.4.

3.5 Non-Standard Batteries

When batteries other than a matching battery cabinet are used, a remote battery disconnect switch with overcurrent protection is required per the National Electrical Code. Contact your local Dual-Lite sales representative about this option.

Install battery racks, cabinets and batteries in accordance with the manufacturer's instructions.

Verify that the battery area has adequate ventilation and battery operating temperature complies with the manufacturer's specifications and with all applicable national and local codes.

If you have any questions concerning batteries, battery racks or accessories, contact Technical Services at 1-800-543-2378.

4.0 MAINTENANCE BYPASS CABINET

The Maintenance Bypass Cabinet is designed to operate in UPS mode, bypass mode and maintenance mode. The mode is selected using the Bypass Switch.

Figure 17 Single UPS with external Maintenance Bypass Cabinet—typical configuration

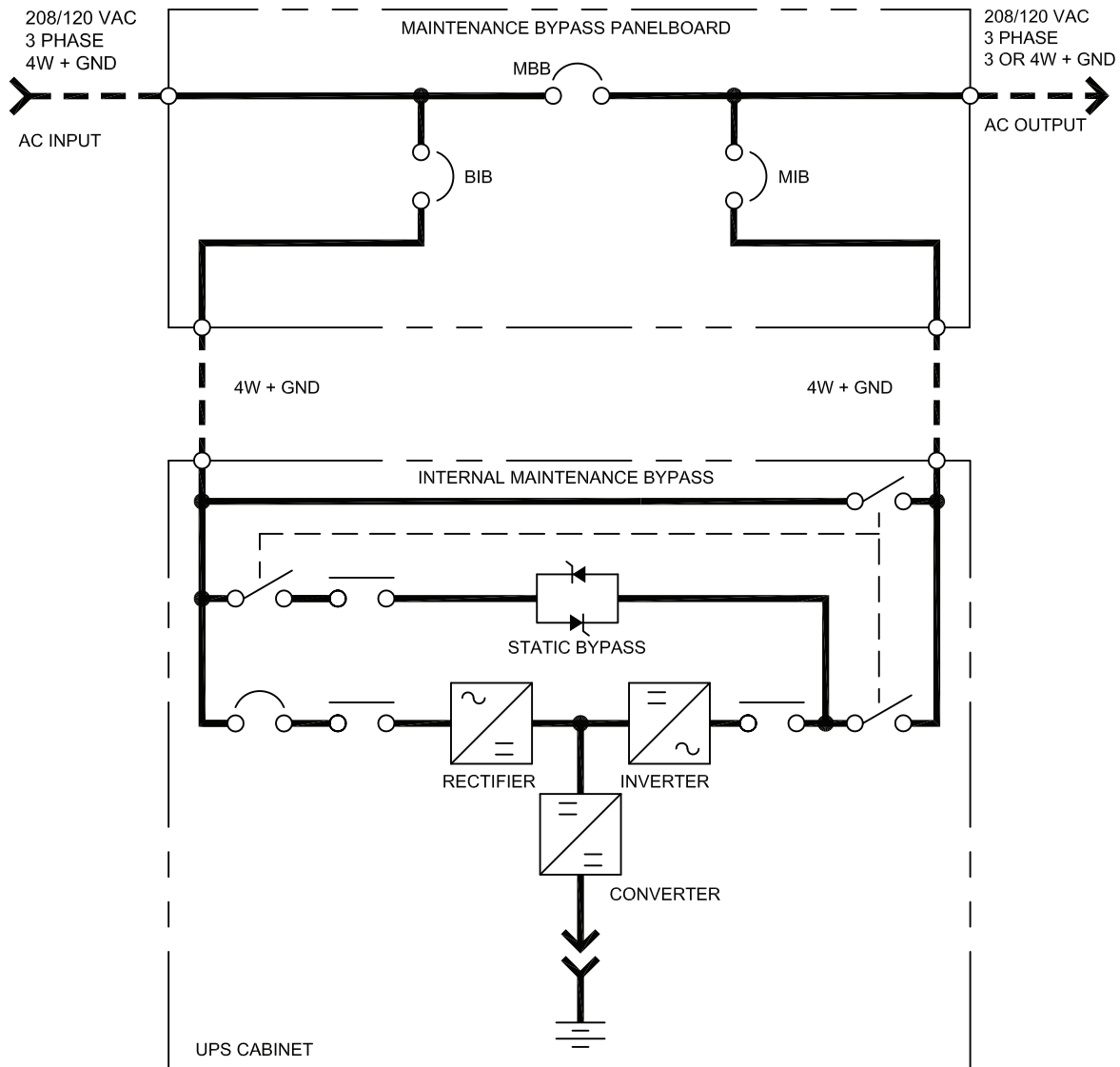

4.1 Bypass Switch

The Bypass Switch allows easy and rapid transfer of connected loads between the UPS and Bypass source.

4.2 Normal (UPS) Mode

While the Maintenance Bypass Cabinet rotary switch is in the NORMAL position, the UPS is supplying the connected load with continuous, high-quality AC power. In this mode of operation, the load is protected by the UPS.

4.3 Bypass Mode

When the Maintenance Bypass Cabinet is in the Bypass mode, it provides an alternate path for power to the connected equipment. Should the UPS need to be taken out of service for limited maintenance or repair, manual activation of the bypass will cause an immediate transfer of the equipment from the UPS inverter to the bypass source. In this mode, power will still be supplied to the UPS; however, the load is NOT protected by the UPS.

4.4 Maintenance Mode

When the maintenance bypass cabinet is in the Maintenance mode, it provides an alternate path for power to the connected equipment. Should the UPS need to be taken out of service for limited maintenance or repair. In this mode of operation, no power is supplied to the UPS and the load is NOT protected by the UPS.

4.5 Locating the Cabinet

This Maintenance Bypass Cabinet may be mounted to the left of the UPS or installed as a stand-alone unit. In either case, ensure that the unit is in a well-ventilated area and that there is clearance for access to the switches and cable connections as required by national and local codes.

4.6 Cable Installation

4.6.1 Wiring Preparation

Be sure that the unit is not connected to any AC utility power source or UPS before installing any wiring to this unit. This Maintenance Bypass Cabinet should be installed by a qualified / certified electrician.



WARNING

Please read this section thoroughly before attempting to install wiring to this unit.

Removing the Cover Plates

Plates cover the input and output terminals on the front of the Maintenance Bypass Cabinet (see **Figure 18**). Remove these and keep the screws and plates for reinstallation.

Figure 18 Maintenance Bypass Cabinet—access plate removed

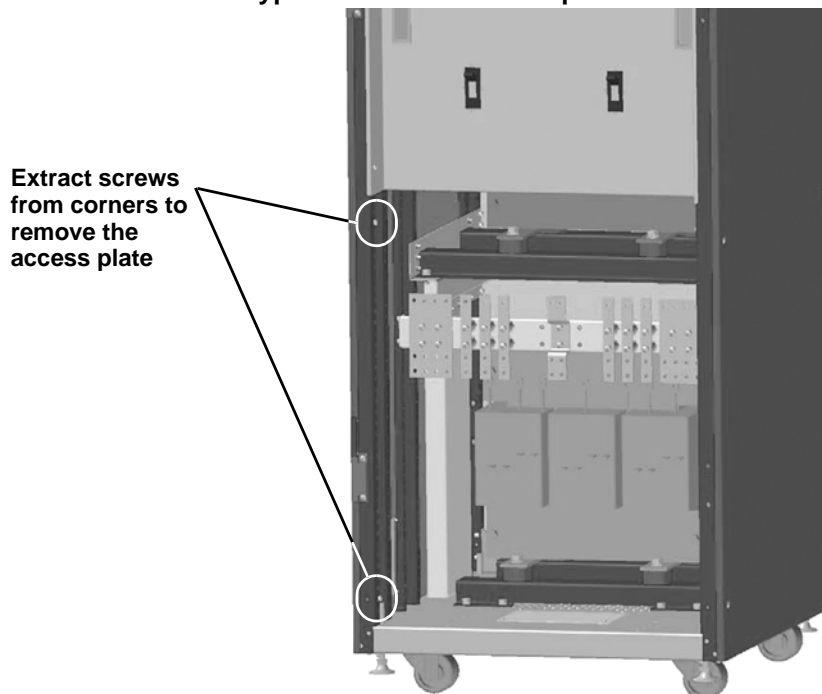

4.6.2 Power Cable Installation

Refer to **Tables 35, 36** and **38** when selecting cables.



NOTE

Transient and steady state earth leakage currents may occur when starting the equipment. This should be taken into account when selecting ground current detection devices because these will carry the earth leakage currents of both the UPS equipment and the load.

4.6.3 Input/Output Wiring

Follow the steps below to connect the input wiring:



NOTE

Input wiring must be installed using conduit if cabinet is not mounted to the immediate left of the UPS.

1. Locate the input wiring access (top or bottom access), remove the conduit landing plate and punch the appropriate size hole for the size conduit being used. Pull the three/four input wires through it, allowing some slack for installation. For cabinets that are located to the immediate left of the UPS, the access plate is on the lower right of the cabinet. Remove the access plate and verify that the edge guarding is installed and intact. See **Figure 19**.

Figure 19 Maintenance Bypass Cabinet wiring access panel

Wiring access is on lower right side of Maintenance Bypass Cabinet

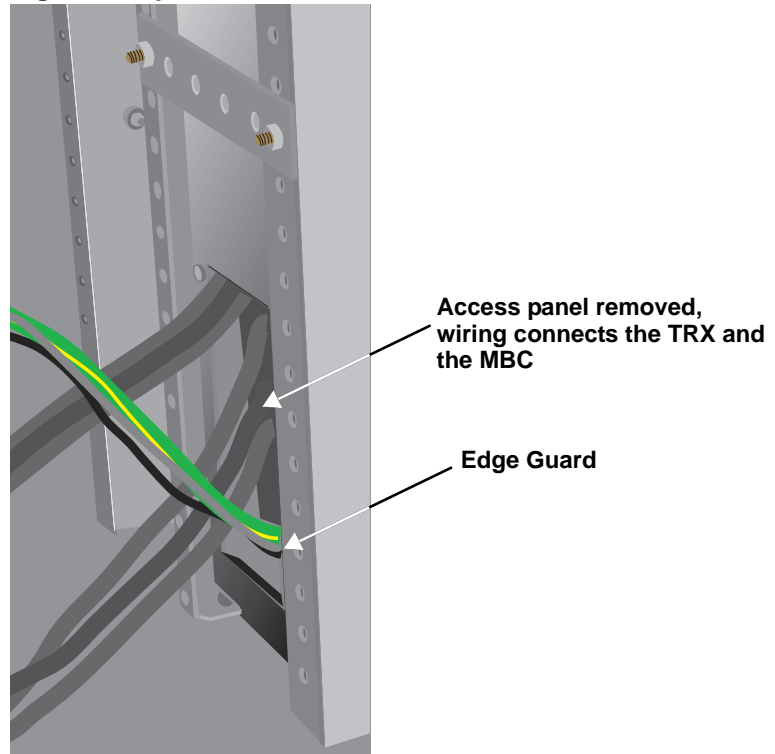

2. Secure the conduit to the access plate of the Maintenance Bypass Cabinet.
3. Input power cables connect to the system input circuit breaker. Refer to **Figure 37 - Maintenance Bypass interconnection**
4. Connect the ground (earth) wire to the earth busbar and tighten it to 44 lb-in. (5 N-m) (M6 bolt).
5. Locate UPS input and output cables and access panel to UPS on lower right side. See **Figure 19**.



NOTE

If the maintenance bypass cabinet is not to be bolted to the UPS, use either top or bottom access plate.

6. Connect the system ground cable between the Maintenance Bypass Cabinet and UPS and tighten the connections to 44 lb-in. (5 N-m) (M6 bolt).

7. Connect the system input cables between the Maintenance Bypass Cabinet 'UPS Input' Busbars (A-B-C N terminals) and UPS input busbars (A-B-C N terminals) and tighten the connections to 44 lb-in. (5 N-m) (M6 bolt).
8. Connect the system output cables between the Maintenance Bypass Cabinet 'UPS Output' Busbars (A-B-C N terminals) and UPS output busbars (A-B-C N terminals) and tighten the connections to 44 lb-in. (5 N-m) (M6 bolt).
9. Connect supplied control wire to X3 on the Parallel (M3) board (see **Figure 20**).



WARNING

The control wire must be installed to ensure proper operation of the system and fully protect the load when switching between bypass cabinet and UPS.

Figure 20 Maintenance bypass control wire location

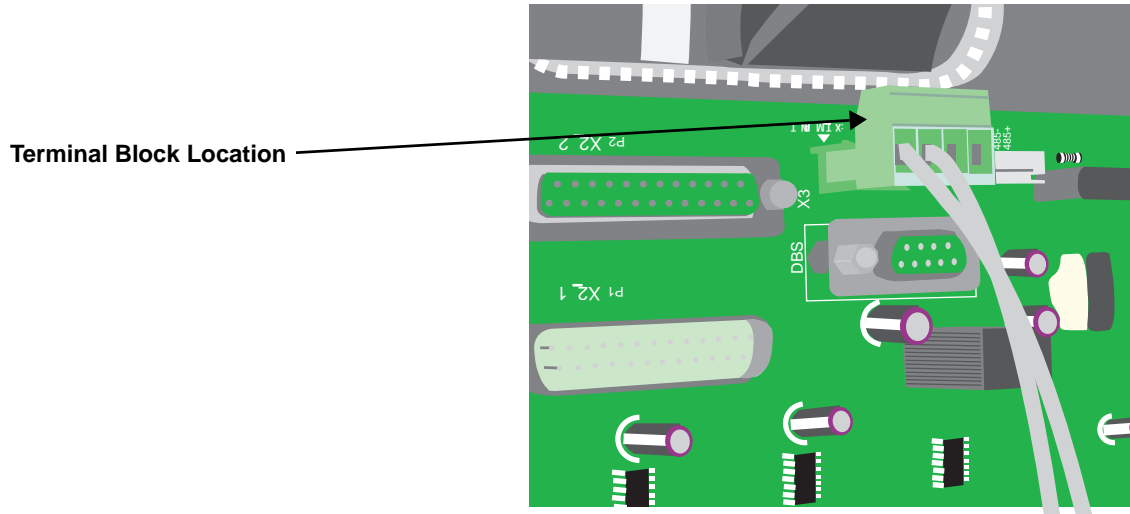

NOTE

For startup procedure, refer to **9.0 - Operating Instructions**.

4.7 Bolting Cabinets Together



NOTE

UPS wiring must be completed before the cabinets are bolted together.

1. Line up cabinets so that mounting holes are aligned.

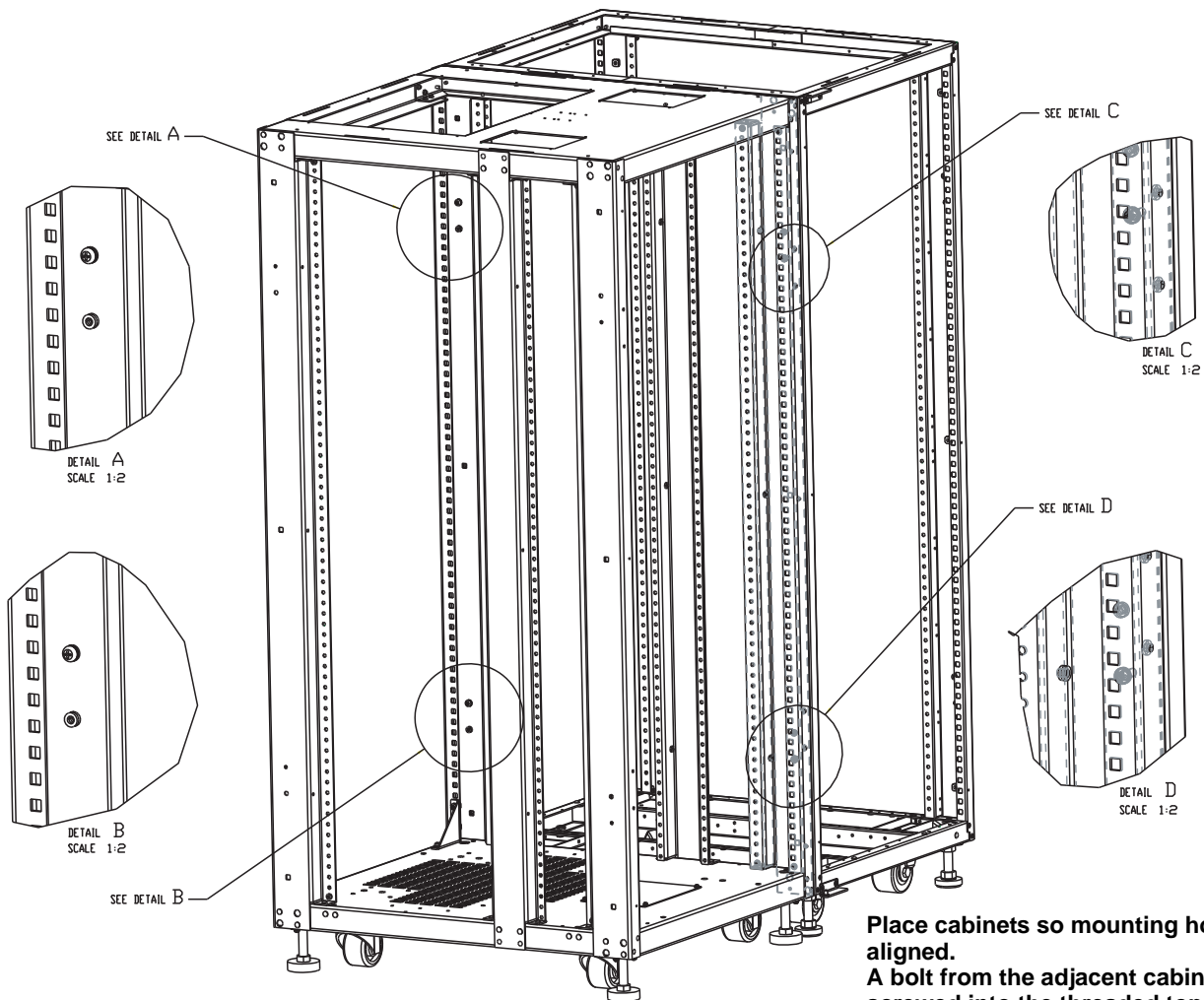

Place cabinets so mounting holes are aligned.
A bolt from the adjacent cabinet may be screwed into the threaded top hole, or a bolt may be inserted through the lower hole and screwed into the threaded hole in the adjacent cabinet.

2. Using supplied hardware, bolt the cabinets together. The bolts may be inserted from either the UPS side or from the MBS side, whichever is more convenient.

5.0 OPTION INSTALLATIONS

5.1 Load Bus Synchronization

The Load Bus Synchronizer (LBS) keeps the output of two independent UPS systems or parallel UPS systems in synchronization even when the systems are operating in different modes and even when either or both systems are operating on batteries. When the LBS is used, one UPS system is designated as master, the other as slave.

The LBS option is typically used with dual-corded equipment or with either the Dual-Lite Smart-Switch or Static Transfer Switch (STS) for single-corded equipment.

5.1.1 Performance Requirements

The DBS operates under the following conditions:

- Both master and slave are on inverter (either system may be on inverter through the rectifier or on inverter through the batteries)
- Master on inverter, and slave on bypass
- Master on bypass, and slave on inverter
- Master and slave on bypass IF the bypass source is the same for both systems

5.1.2 DBS Cable and Settings

For TRX-to-TRX dual bus configuration, only one optional LBS cable is required, the built-in LBS will operate normally without extra LBS control box or interface box. The LBS port is X4 on the parallel board (M3). The parallel board is on the interior of the TRX, above and left of the power electronics; see **Figure 32**.

An optional, 9-pin LBS cable is used to connect two UPS systems through each system's DB9 port on its parallel board. For two parallel systems, the LBS cable can be mounted between any two units belonging to different parallel systems. For information about the LBS kit or to order the optional equipment, see your local sales representative.

The LBS cable is connected as illustrated in **Figure 21**.

Figure 21 Load Bus Synchronization cable connection

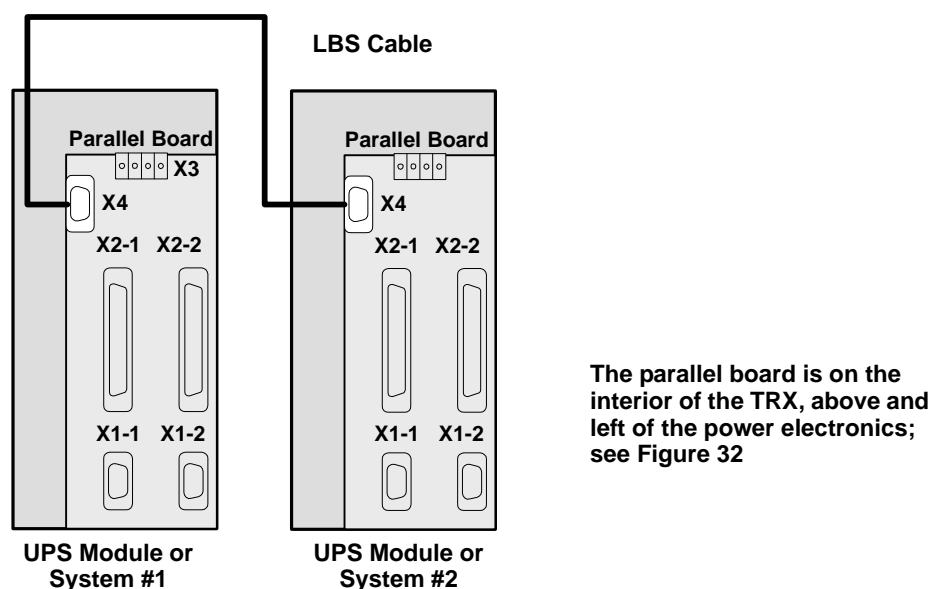

The LBS function is activated with configuration software; when the LBS takes effect, the graphic LCD will display "LBS active."

5.2 Configuring Parallel System Operation

5.2.1 General

The TRX uses intelligent and reliable decentralized technology to achieve parallel operation of two or more modules of the same rating.

The 1+N system is used to:

- Increase the reliability of the system to ensure adequate power supply to the critical load connected.
- Increase serviceability and allow the execution of maintenance operations and reparations without affecting the ordinary operating conditions of the system (depending on the redundancy level).

5.2.2 Features of Parallel System

- The hardware and firmware for parallel UPS module operation is standard in the TRX, and the configuration can be set up by changing the settings in configuration software.
- It is easy to install the parallel cables in a ring, providing high reliability and redundancy. And the intelligent paralleling logic provides the user with maximum flexibility. For example, shutting down or starting up the UPS modules in the parallel system can be done in any sequence. If an overload transfer occurs, the whole system can recover automatically from bypass mode after the overload is cleared.
- The total load of the parallel system can be queried from each module's liquid crystal display screen.

Figure 22 1+N system block diagram

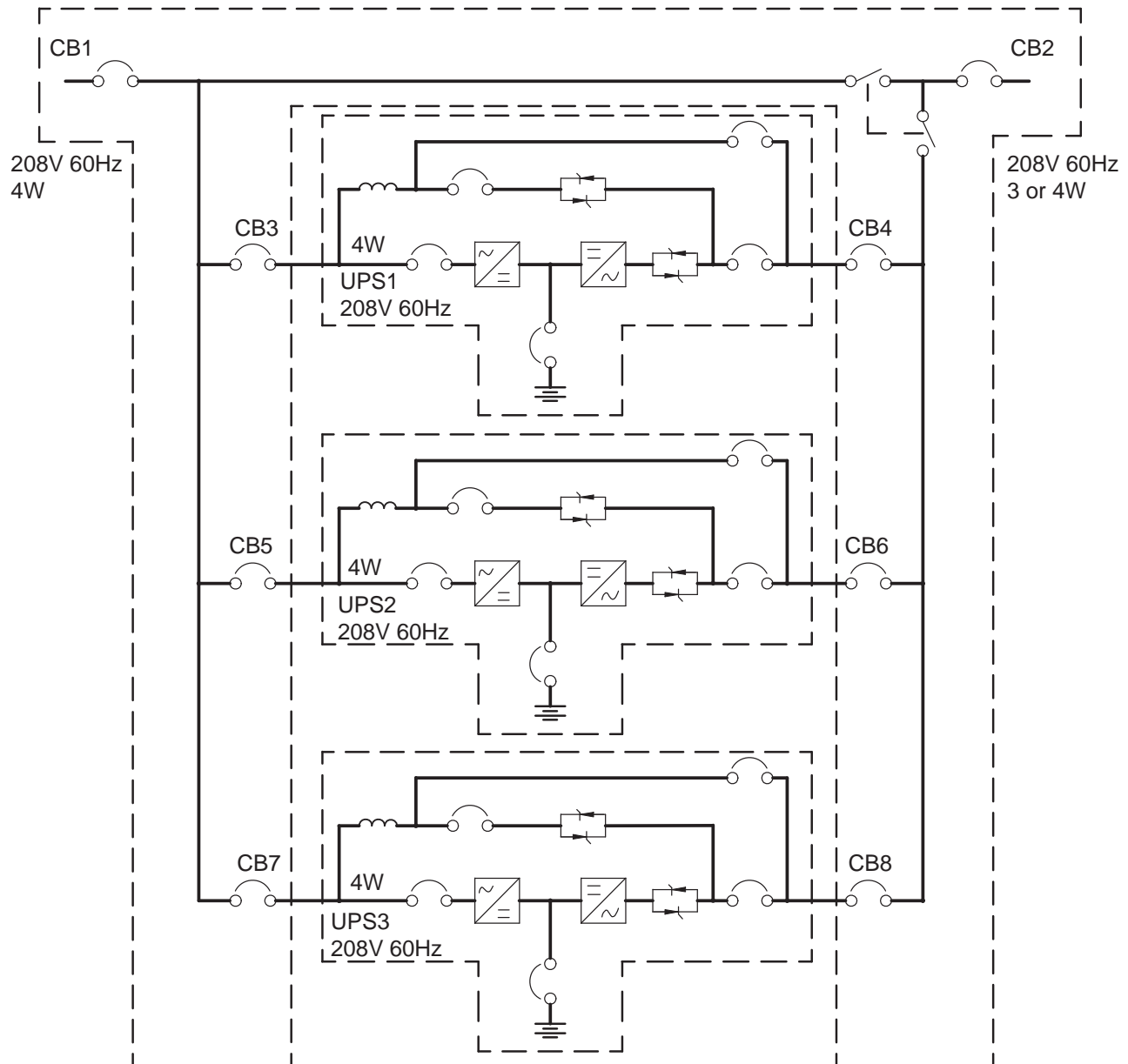

NOTES:

1. Install in accordance with national and local electrical codes.
2. The equipment ground connection must be connected to the system ground wire.
3. UPS AC input and AC output cables must be run in separate conduits.
4. Control wiring and power wiring must be run in separate conduits.
5. See Electrical Data Specification Sheet U3818101 for individual configurations.

5.2.3 Operating Principles

Redundancy Paralleling

The 1+N parallel redundant system can noticeably improve system reliability. In normal condition, none of the UPS modules work at full load. That means that even if the load is increased, the system will not transfer to bypass. And when a UPS module shuts down due to any failure, the remaining UPS modules can still power and protect the load. When redundancy is lost due to module failure or load increase, the parallel system will trigger an alarm.

5.2.4 Operation Modes Summary

The parallel system also has operation modes such as normal, battery, bypass and maintenance bypass. All UPS modules in the 1+N parallel system operate in coordination.

- **Normal Mode Operation**

The load is powered by the inverters of all the UPS modules in the system. If the frequency of bypass is within the synchronous range, the inverter will be synchronized with the bypass. Otherwise, the system will operate at nominal frequency.

- **Battery Mode Operation**

The batteries of all UPS modules power the load through their inverters. The system operates at nominal frequency.

- **Bypass Mode Operation**

The condition to transfer to bypass mode is essentially the same as that of single-module system. The bypass of all the UPS modules powers the load.

- **Maintenance Bypass Mode Operation**

The sequence to transfer to maintenance bypass mode is the same as for transferring a single-module system. The maintenance bypass switches should be switched on as synchronously as possible. Thus the system can be repaired without interrupting the power supply to critical load.

5.3 Installing Parallel System

The basic installation procedure of parallel system is the same as that of single-module system. The following sections introduce only the installation procedures specific to the parallel system.

5.3.1 Conditions for Parallel System

- Each UPS module should have the same rating, the same firmware and hardware version.
- Each UPS module must have the same bypass source.
- The outputs of all UPS modules are connected altogether.
- The main inputs can be from different sources, but the phase rotation sequence of main inputs, bypass inputs and outputs must be correct and the same.
- The parallel logic cable and load sharing cable must be connected in a ring correctly (see **Figure 23**).

5.3.2 Cabinet Installation

Parallel system composed of two or more UPS modules using parallel cabinet

The UPS modules that will form the 1+N system should be placed side-by-side. Each battery cabinet is placed next to its corresponding UPS module.

The parallel cabinet should be placed in the middle of the system.

5.3.3 Preliminary Checks

Each UPS module should have the same rating, the same firmware and the same hardware version. Refer to the instructions in **5.3.1 - Conditions for Parallel System**.

5.3.4 Protective Devices

For each UPS, refer to **Table 27**. For each system, refer to **Table 37**.

5.3.5 Power Cables

Wiring of power cables is similar to that of single-module system (See **2.1 - Power Cabling**). The bypass sources of all modules should be the same, and the outputs should be connected altogether correctly.

Power cables will be supplied by customer. Power cables to the UPS's of the 1+N paralleling cabinet must be routed through either the top or bottom entry access of the UPS.

For systems using a parallel cabinet, see **Figures 38** and **40** through **42** for power cable terminations.



NOTE

The length and specifications of power cables including the bypass input cables and UPS output cables should be the same, thus the load can be shared evenly in bypass mode.

5.3.6 Parallel Control Cables

Parallel System Control Cables

Make the connections listed below on the parallel logic board (M3) inside the TRX. (See **Figure 32** for the location of the parallel logic board):

Shielded and double-insulated control cables available in lengths of up to 100 feet (30m) must be interconnected in a ring configuration between UPS modules as shown below. The ring configuration ensures high reliability of the control (refer to **Figure 23**).

See **Figure 25** for dry contacts control cable wiring diagram.

Figure 23 Connecting '1+N' system parallel control cables

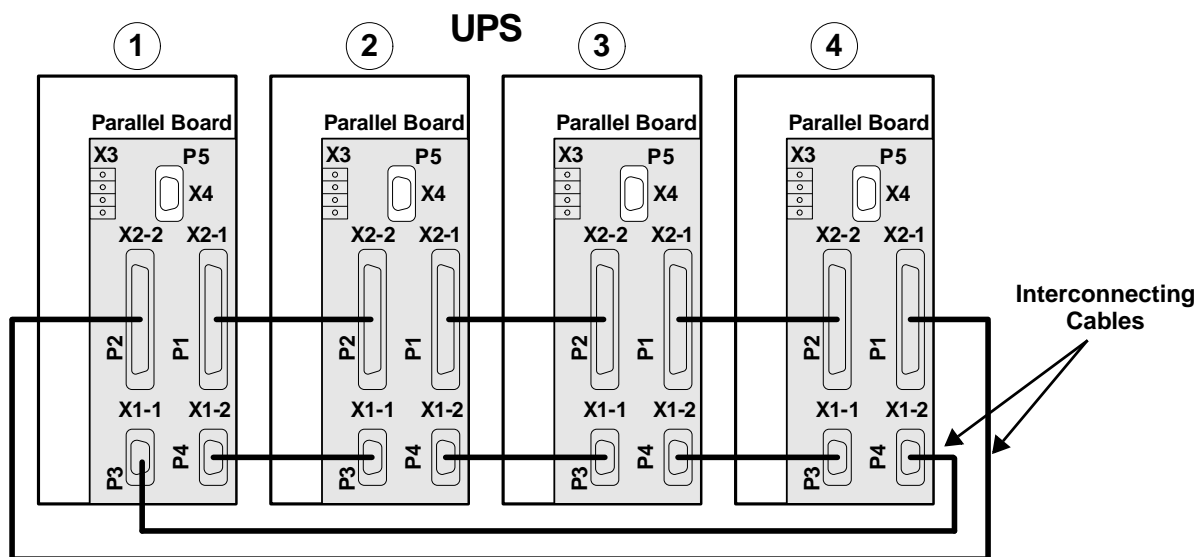

Auxiliary Dry Contact Cables

The external output breaker of each UPS must have Normally Open auxiliary contacts. These contacts must be wired to connector X3 on the Parallel Logic Board (M3). See **Figure 24**.

Figure 24 Auxiliary dry contact cables for output breaker in multi-module system

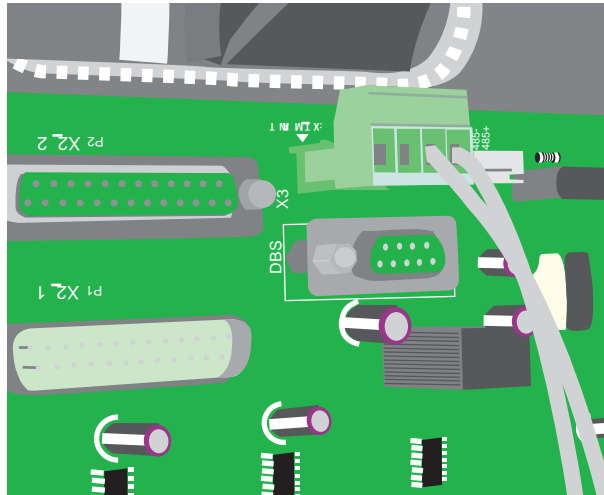

CAUTION

The auxiliary control wire must be installed to ensure proper operation of the system.



NOTE

For startup procedure, refer to **9.0 - Operating Instructions**.

Figure 25 Dry contacts, multiple UPS modules with distribution panel

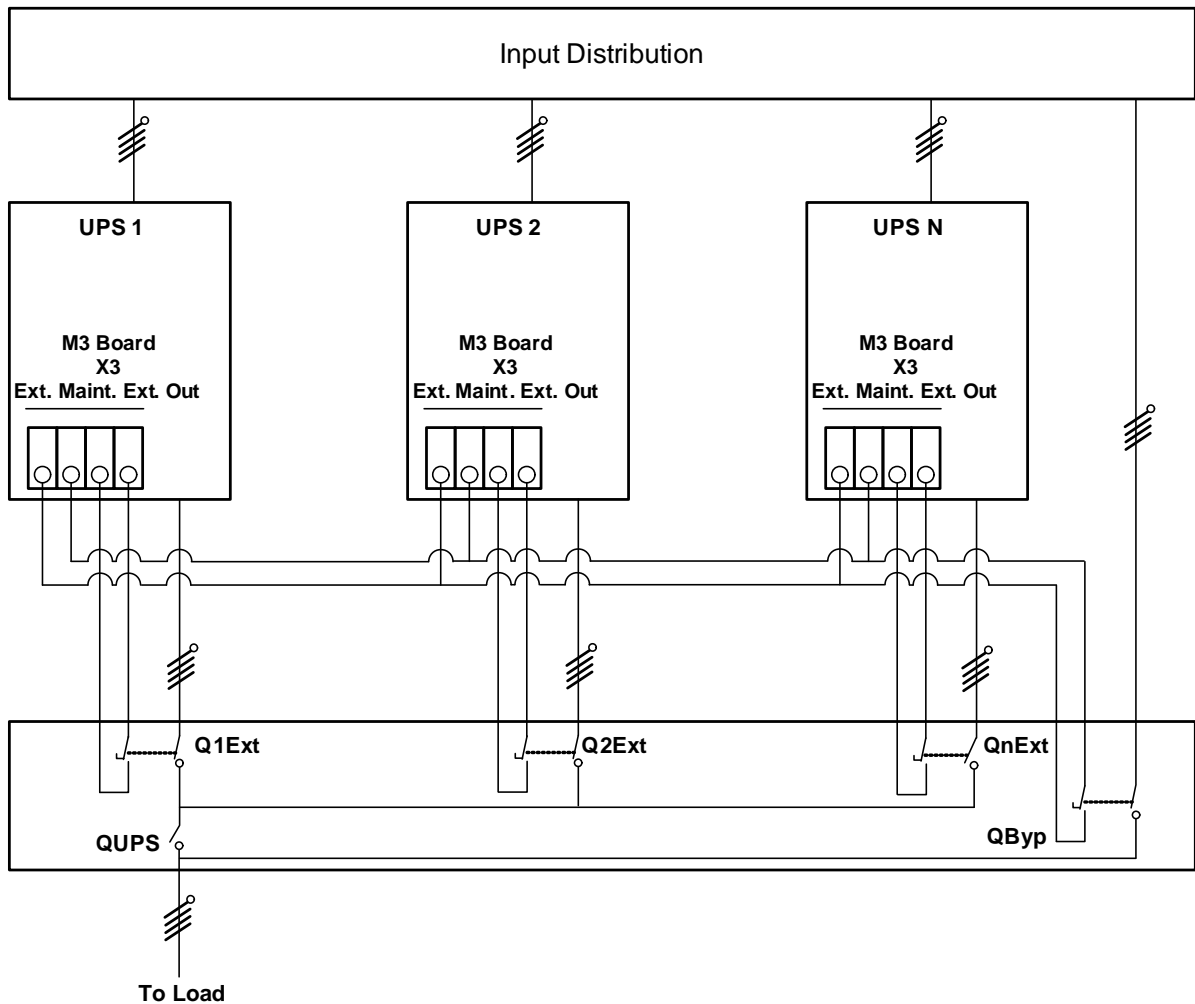

5.3.7 Emergency Power Off (EPO)

The external emergency stop facility is identical to that described for the single-unit installation—that an individual emergency stop button is provided for each unit.

Figure 26 Connecting EPO push button

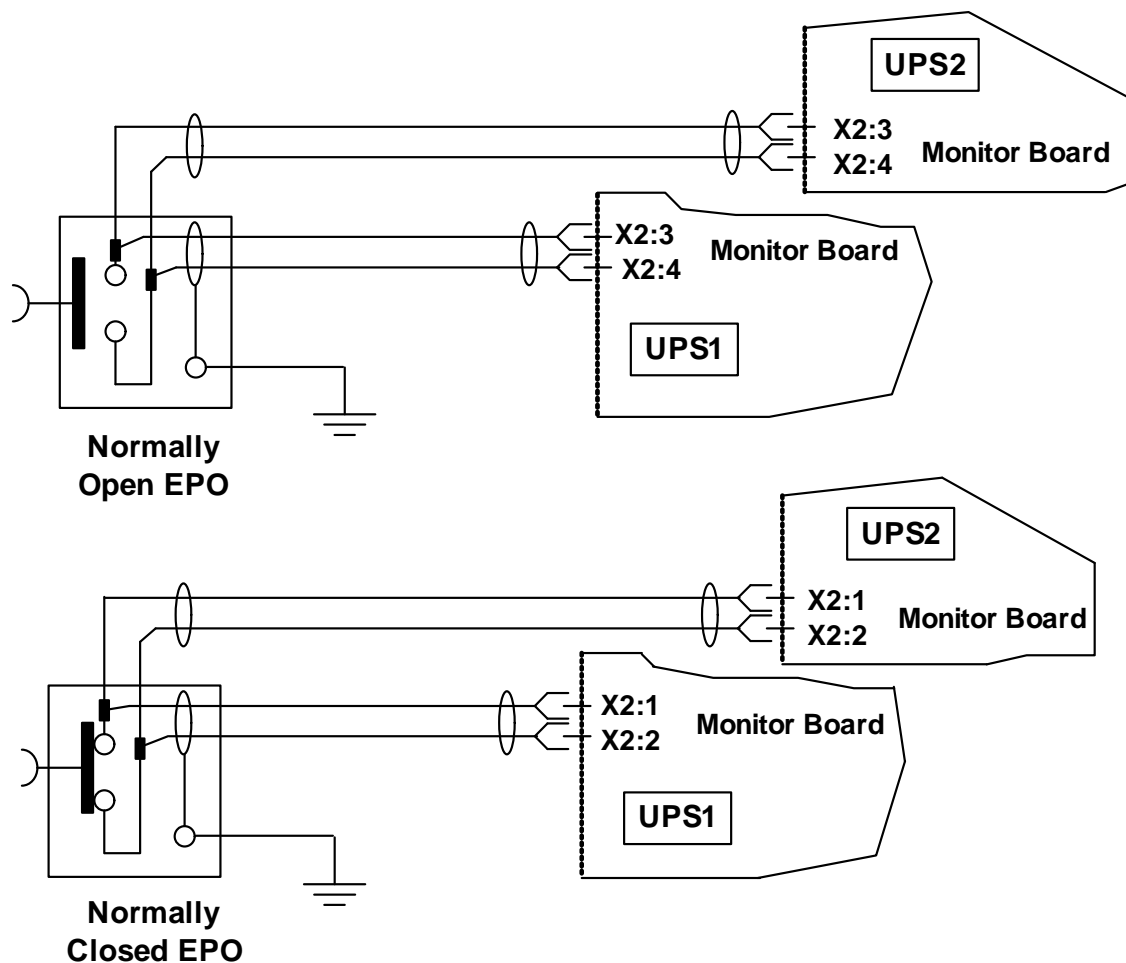

5.4 Battery Circuit Breaker Box

The box contains the same battery isolating circuit breaker as mounted in the battery cabinet.

Two battery circuit breaker boxes are available for use in installations where the battery is not installed in the battery cabinet, in which case the appropriate battery box is fitted as close as possible to the battery and connected to the UPS equipment as illustrated in **Figure 27**.

The battery circuit breaker box, is required to protect the battery from overcurrents. It also provides electrical isolation between the UPS and the battery, permitting technical service personnel to reduce the risks involved in maintenance work to a minimum.

A separate safety earth must be connected between the UPS unit and circuit breaker box.

Two boxes are available depending on the UPS power rating.

Table 7 Available battery circuit breaker boxes

UPS	Dimensions (in) H-W-D	Circuit Breaker
10-15 kVA	32.25x20.25x8.3	70A
20-30 kVA	32.25x20.25x8.3	125A

The circuit breaker has the following features:

- Short-circuit protection.
- Protection against battery cabinet and ups connection errors (polarity reversal +/-).

Figure 27 Battery circuit breaker box connections

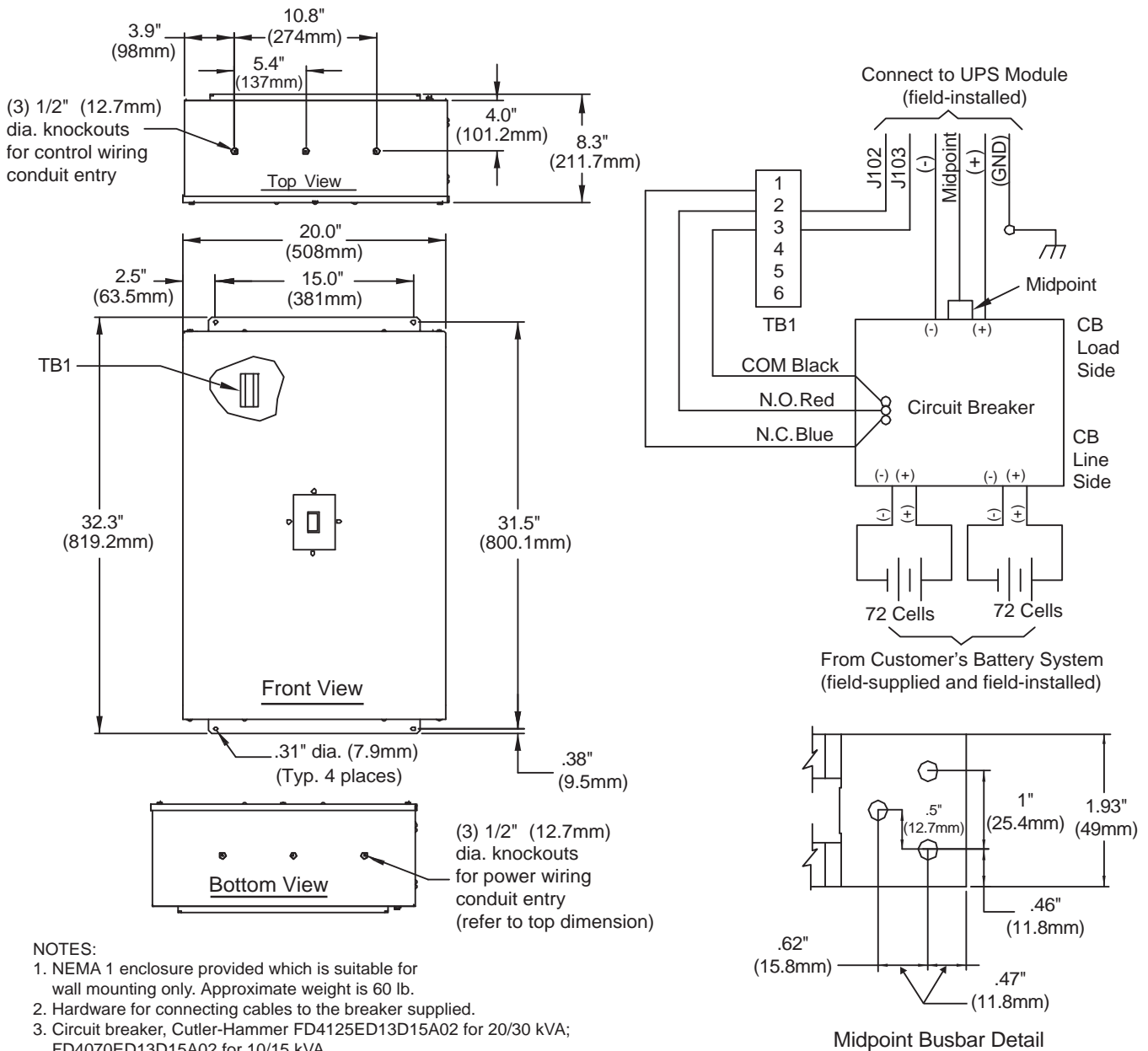

NOTES:

1. NEMA 1 enclosure provided which is suitable for wall mounting only. Approximate weight is 60 lb.
2. Hardware for connecting cables to the breaker supplied.
3. Circuit breaker, Cutler-Hammer FD4125ED13D15A02 for 20/30 kVA; FD4070ED13D15A02 for 10/15 kVA
4. Color: IBM off-white.
5. Mount enclosure and pull all cables into enclosure before installing dry contacts.
6. Low voltage wiring needs to enter from the top of the enclosure, in separate conduit from power cables.
7. Line side power connections to lugs: (1) # 6AWG per connection for 10 to 15 kVA. (1) # 2AWG per connection for 20-30 kVA to lugs; load side power connections to busbars; see detail.
8. Power cables must be sized to limit voltage drop from battery system to UPS to be a maximum 4 VDC.

DPN U3813078 Rev. N



NOTE

1. The signal cables in this figure must be shielded and double-insulated.
2. Connect the Pes (Protection Earth) of the UPS cabinet and BCB box to the same point.

5.5 Battery Start

With this option, the TRX UPS can be started with power supplied only by the batteries (at charged condition). This type of start, in the absence of utility power, allows independent utilization of battery power and provides for higher availability in some circumstances.



CAUTION

Before attempting to start the UPS without utility power present, ensure that the batteries are fully charged—over 2.1V per cell—and will supply adequate run time to the load.

5.6 Remote Alarm Monitor

Status and alarm conditions are available on an optional remote alarm monitor (RAM) panel which is driven by voltfree alarm status contacts (from an optional relay alarm board).

5.7 Analog Input Interface

At the X6 slot, there are two analog signal channels. Input range is from 0 to +5V, and the precision is 2 percent. “ENV-T” is used for environment temperature detecting.

5.8 Power Output

The X5 slot can provide power for a modem or an external SNMP card. Available voltage is from 9V to 12V. The maximum current is 500mA.

5.9 IntelliSlot Communication

The TRX has three IntelliSlot ports to allow field-installation of optional communication cards. IntelliSlot cards communicate via the manufacturer’s proprietary ESP2 protocol to cards that translate the information into such protocols as SNMP, IGMnet, Modbus or Jbus. Other cards provide dry contact signals for external signaling of operating status.

The IntelliSlot communication ports may be installed or removed while the TRX is operating.

5.10 OC Web Card—SNMP/HTTP Network Interface Card

This network interface card provides all real-time data and status information as SNMPv1 traps for connection to a 10/100-baseT Ethernet connection. The same card also will transmit the same status information and all measured parameters for display via a Web browser.

Table 8 TRX communication options

Physical description of port	Labeled ID Name of Port	On the UPS LCD screen, under Settings, controlled by:	Monitoring Devices supported	Baud rate	Comments
Top IntelliSlot	Intellislot 1 (On Monitor Board)	Comm 1	Multiport 4	any	
			Relaycard-int	any	
			OCWEB-LB	2400	Not simultaneous with MultiLink in RS232-1
			Modbus/Jbus	2400	
Middle IntelliSlot	Intellislot 2 (On Monitor Board)	Comm 2	Multiport 4	any	
			Relaycard-int	any	
			OCWEB-LB	2400	Not simultaneous with MultiLink in RS232-2
			Modbus/Jbus	2400	
Bottom IntelliSlot	Intellislot 3 (On Monitor Board)	Comm 3	Multiport 4	any	
			Relaycard-int	any	
			OCWEB-LB	2400	
			Modbus/Jbus	2400	
Top DB9 port	RS232-1	Comm 1	MultiLink Serial	9600	Not simultaneous with Web card in top IntelliSlot.
Bottom DB9 port	RS232-2	Comm 2	Service Software (Reserved)	9600	Not simultaneous with Web card in middle IntelliSlot.

5.10.1 Configuring Baud Rates

The default baud rate for IntelliSlots is 9600. To communicate with the OCWEB-LB, Modbus/Jbus, or the MultiLink cards, the baud rate must be set to 2400.

To change the baud rate (refer to **Table 8**):

1. Use the Navigation keys directly below the LCD to highlight the Settings Screen.
2. Press F1 to move the highlight into the Data & Settings area of the LCD.
3. Use the Navigation keys to scroll down to highlight the current baud rate across from the appropriate Comm Channel.



NOTE

The Comm channel settings are not immediately visible because of window-size constraints. Scroll down to view them on the screen.

4. Press the Enter (F4) key to select the Comm Channel to change.
5. Navigate to underline the desired baud rate (2400).
6. Press the Enter (F4) key to lock in the new baud rate.

Figure 28 OC Web card display

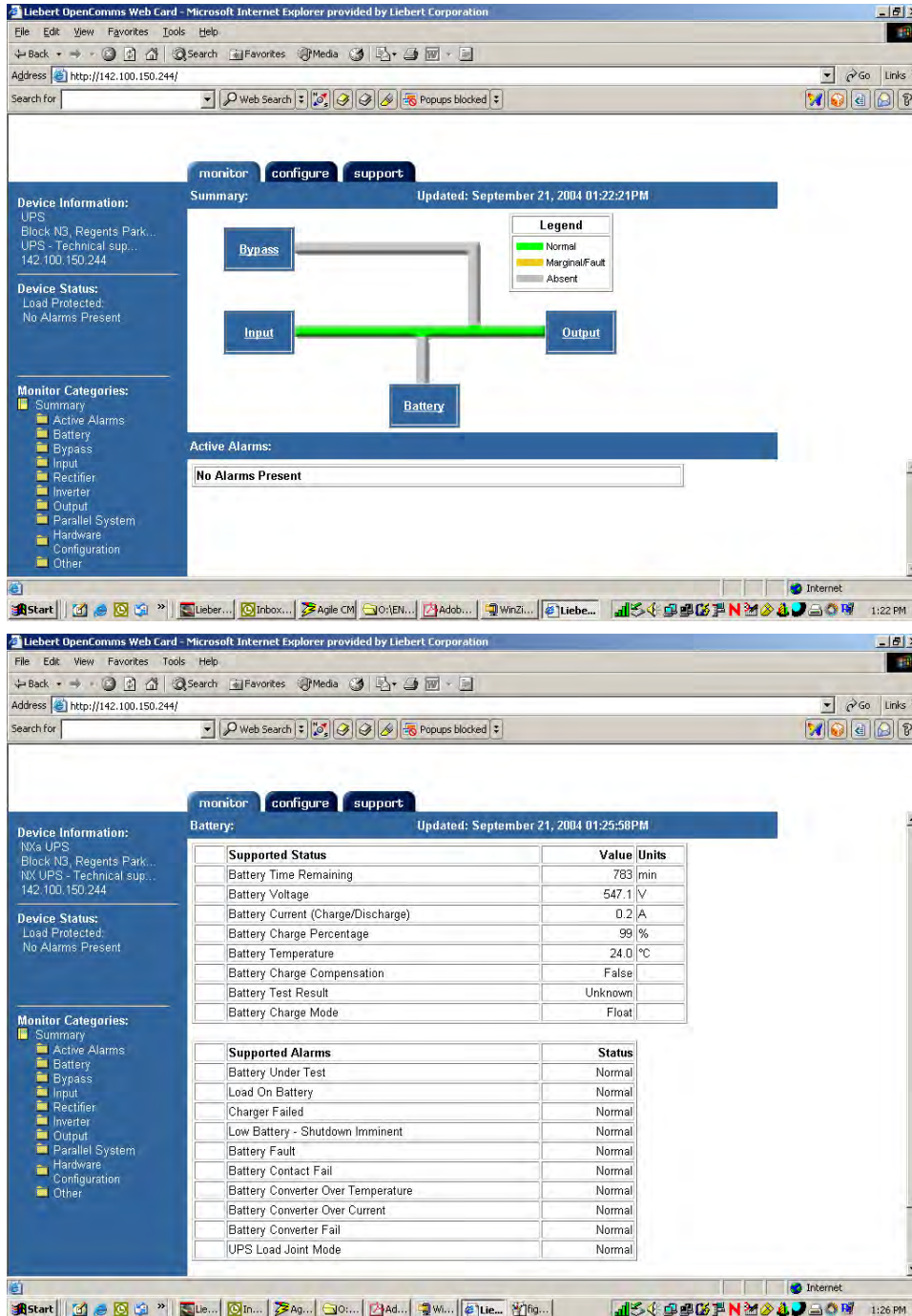

5.11 Relay Card

The relay card provides voltage-free contact closures for remote monitoring of alarm conditions.

Delivering **On Battery, On Bypass, Low Battery, Summary Alarm, UPS Fault** and **On UPS** signals, the easy-to-install card integrates with AS/400 computers (additional cable required) and other relay contact monitoring systems.

The relay card is rated for 24 VAC/DC at 1A. and supported in any of the three IntelliSlot bays on the TRX.

Table 9 Relay Card pin configuration

Pin	Function	Operation
1	UPS Fault	Closed if no UPS failure
2-3	Not Used	
4	UPS Fault	Closed if UPS fails
5	Summary Alarm**	Closed if SUMMARY ALARM** occurs
6	Summary Alarm**	Closed if no alarm conditions are present
7	Any Mode Shutdown return	Not supported – use External EPO terminal
8	Not Used	
9	Common - Low Battery	
10	Low Battery	Closed if battery is OK
11	Low Battery	Closed if LOW BATTERY point occurs.
12-13	Not Used	
14	UPS Any Mode Shutdown	Not supported – use External EPO terminal
15	On UPS	Closed if ON UPS (inverter) power
16	On Battery	Closed if ON BATTERY power (Utility failure)
17	Common - UPS Fault, Summary Alarm, On UPS, On Battery, On Bypass	
18	On Battery	Closed if not ON Battery power (Utility OK)
19±23	Not Used	
24	On Bypass	Closed if ON BYPASS
25	Not Used	

**A Summary Alarm occurs when any of the following conditions exist:

1. Utility power is out of the acceptable range (voltage and/or frequency).
2. UPS is in BYPASS MODE (load not on Inverter power).
3. UPS Battery is LOW.
4. UPS fault has occurred.

Table 10 Relay card jumper configuration

Number	Connection	Description
JP01	Pin 9 to Pin 17	Allows all relay COMMONS to be tied together.
ANY JP02	Pin 7 to Pin 17	REMOVE - (Interconnects all relay COMMONS and the (not supported) MODE SHUTDOWN Return

5.12 MultiPort 4 Card

The MultiPort 4 card provides four sets of voltage-free contact closures for remote monitoring of alarm conditions UPS operation On Battery and battery low condition. A typical application is to allow a maximum of four computer systems to simultaneously monitor the status (e.g., utility power failure-low battery) of a single UPS.

This card is supported in any of the three IntelliSlot bays on the TRX.

Figure 29 MultiPort 4 card pin assignment

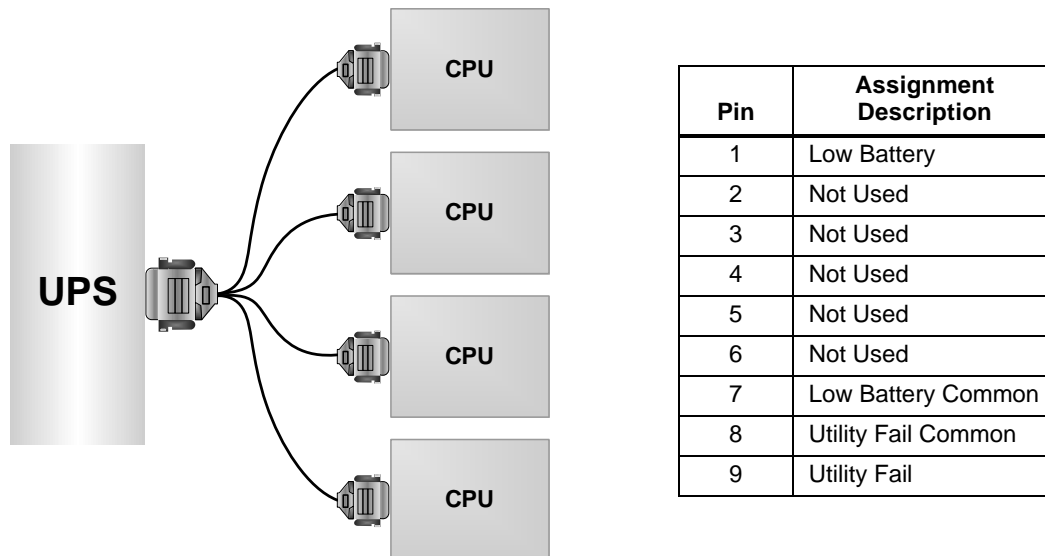

6.0 INSTALLATION DRAWINGS

The diagrams in this section illustrate the key mechanical and electrical characteristics of the TRX UPS System cabinets.

Figure 30 Dimensional view- front and left side views

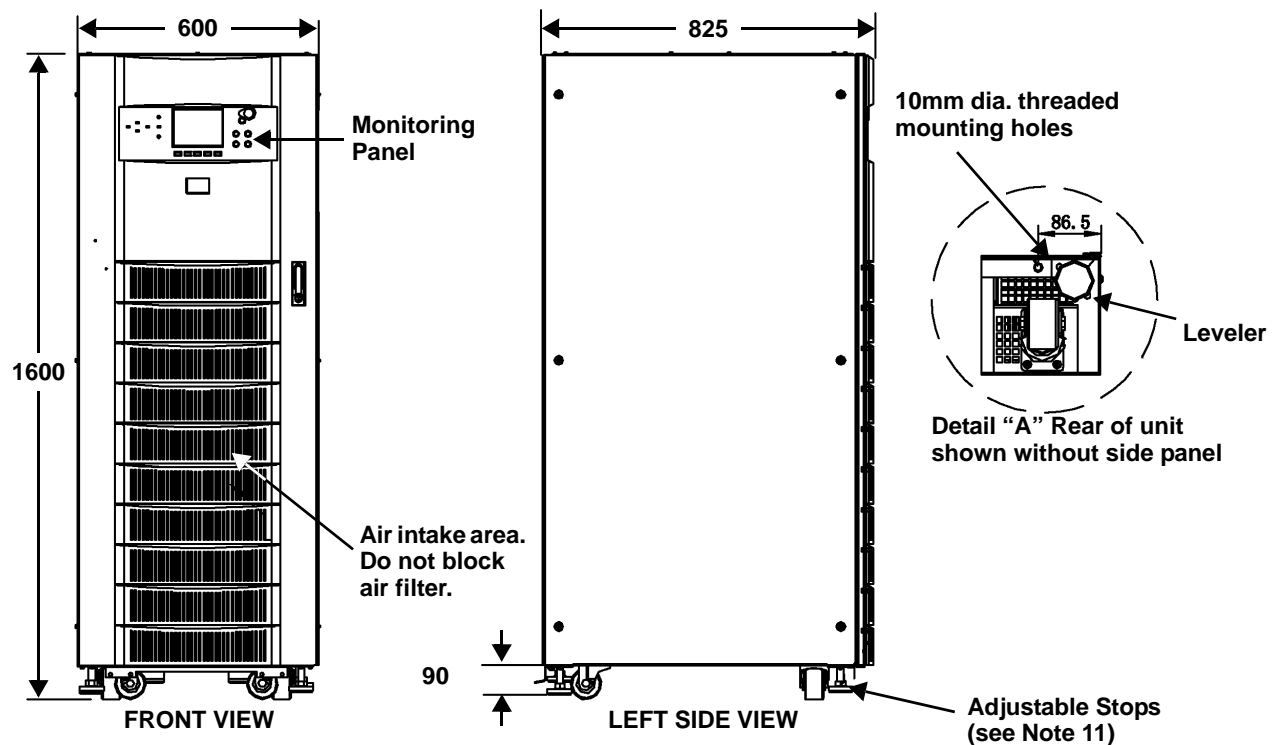

1. All dimensions are in millimeters.
2. A minimum of 24 inches clearance above the unit is required for air exhaust.
3. Installation and service access required. Left-side access recommended for maximum ease of installation.
4. Keep cabinet within 15 degrees of vertical while handling.
5. Top and bottom cable entry available through removal access plates. Remove punch to suit conduit size and replace.
6. Unit bottom is structurally adequate for forklift handling.
7. Open door to replace air filter, washable type, size 354x314.
8. Threaded mounting holes used for seismic anchoring or floor stand. **Note:** If a floor stand is used, the weight of the unit must be supported under all casters.
9. Each mounting location is supported by two 10 GA. (.135") galvanized steel. The threaded 12mm insert is approximately 3/4" deep. Mounting bolts must be threaded into unit.
10. Includes side panel. Refer to Detail A for dimension to frame with side panel removed. Side panels are removed between adjacent units that are bolted together.
11. Adjustable stops are not designed to carry the full weight of the cabinet. Finger-tighten stop against the floor, then tighten with a wrench less than two turns for friction against the floor.

Figure 31 Dimensions continued—top and bottom views

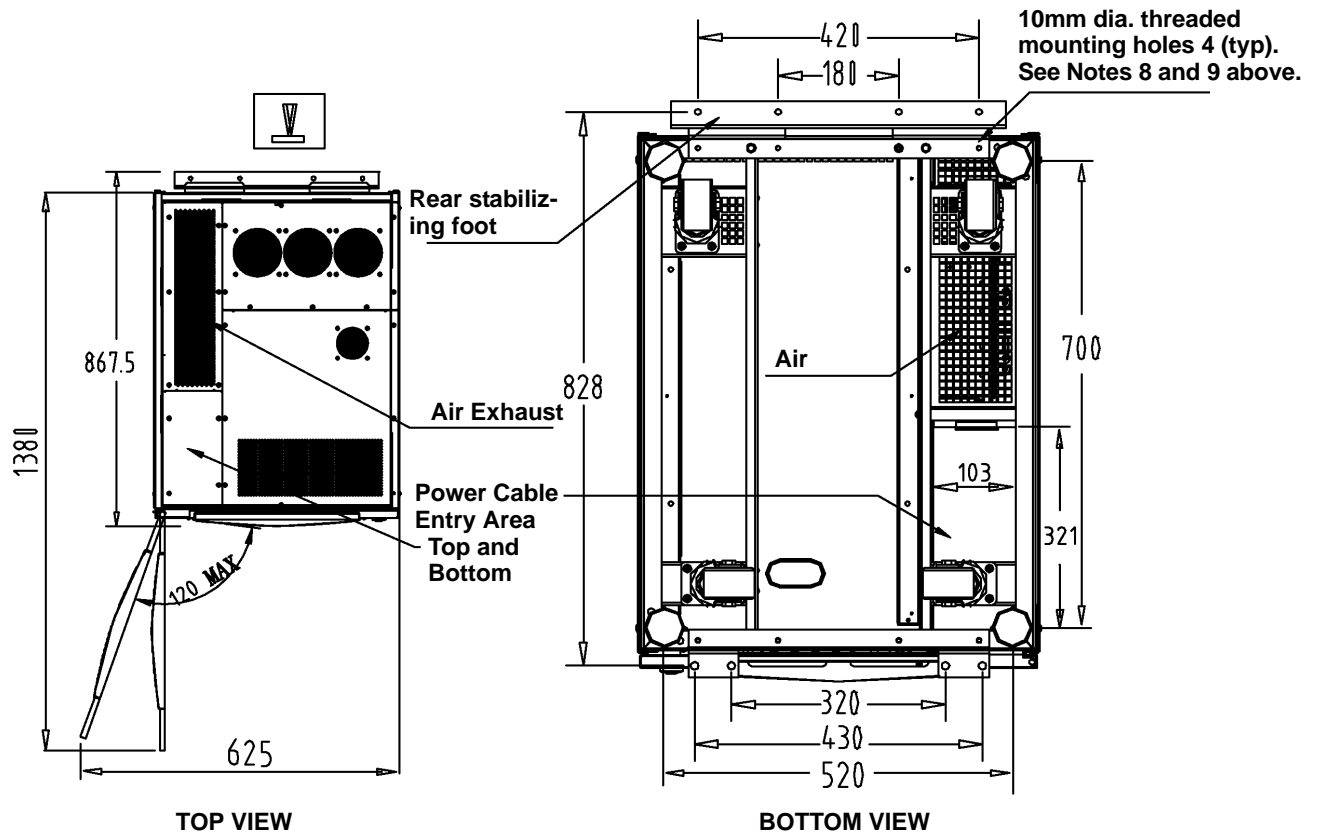
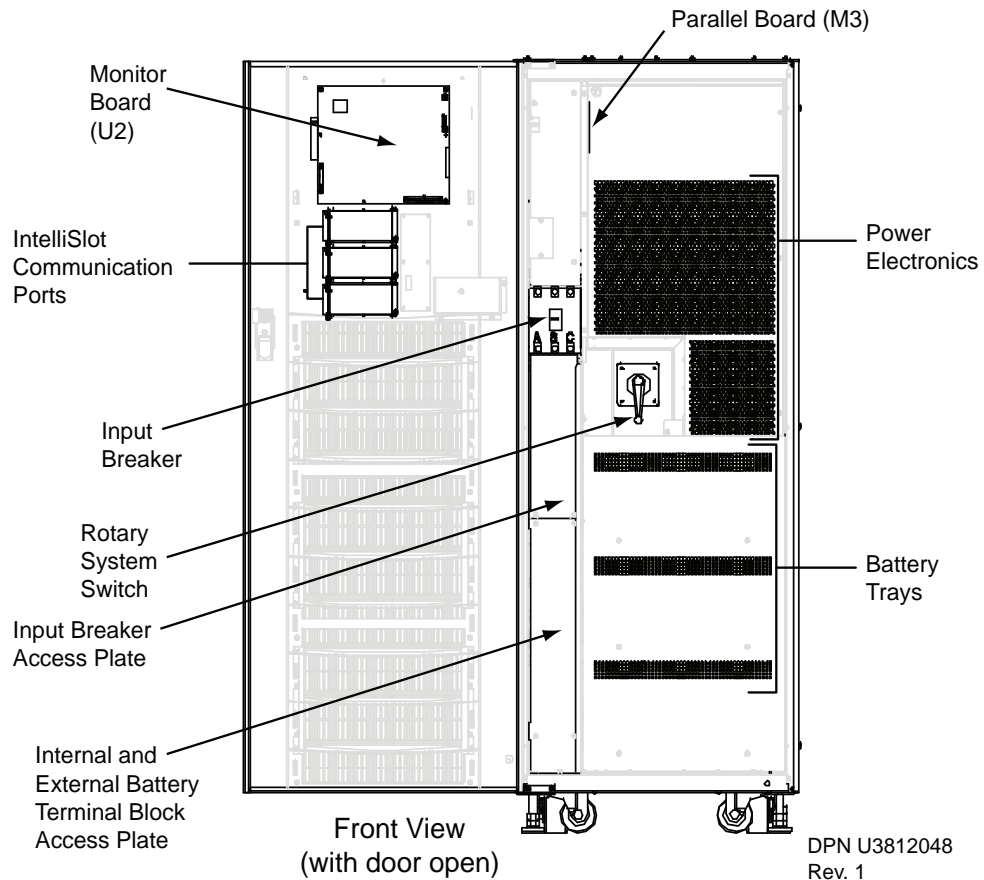
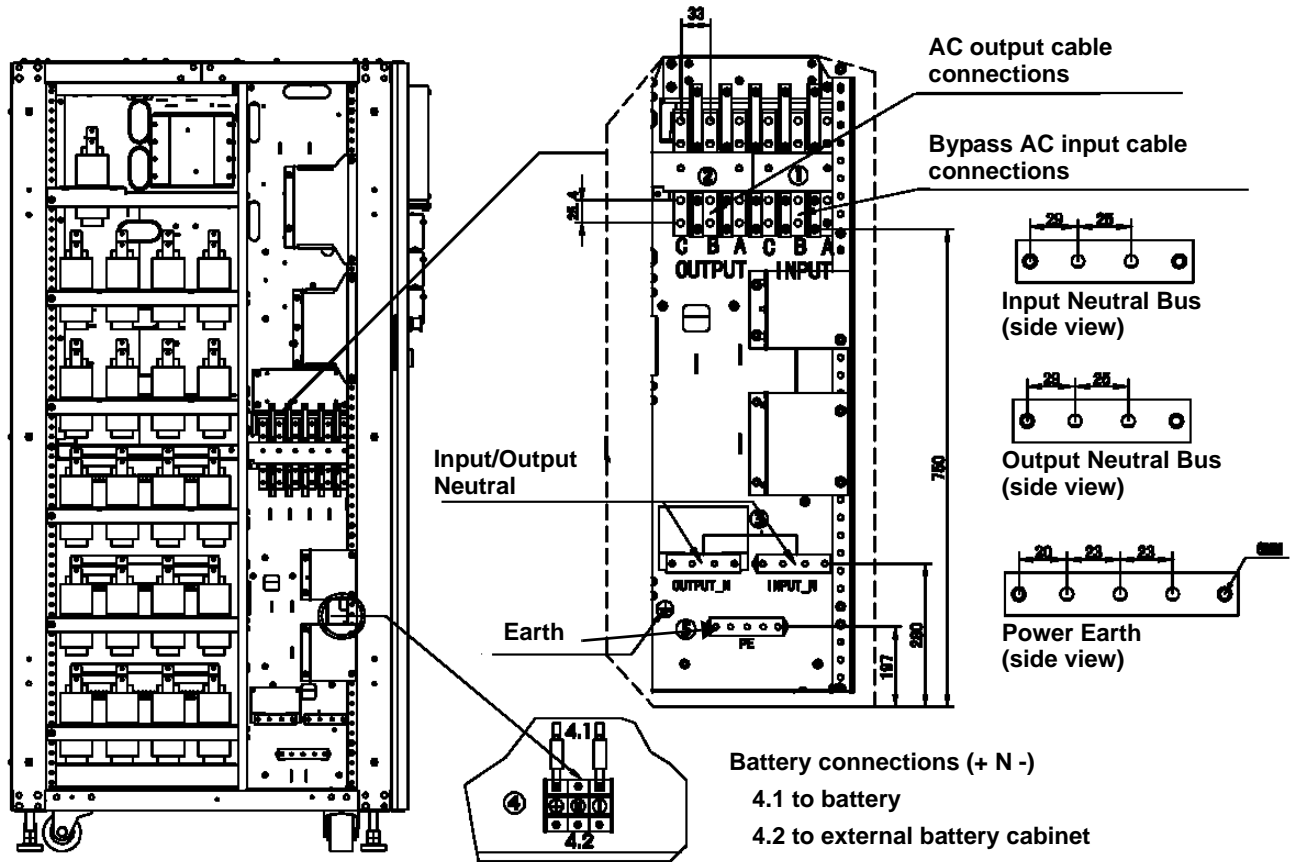

Figure 32 Main components—typical unit



DPN U3812048
Rev. 1

Figure 33 Cable connections



NOTES

1. All dimensions are millimeters.
2. Top and bottom cable entry available through removable access plates. Remove, punch to accommodate conduit size and replace.
3. Control wiring and power wiring must be run in separate conduit. Output and input cables must be run in separate conduit.
4. Aluminum and copper-clad aluminum cables are not recommended.
5. All wiring is to be in accordance with national and local electrical codes.

Figure 34 Location of internal batteries

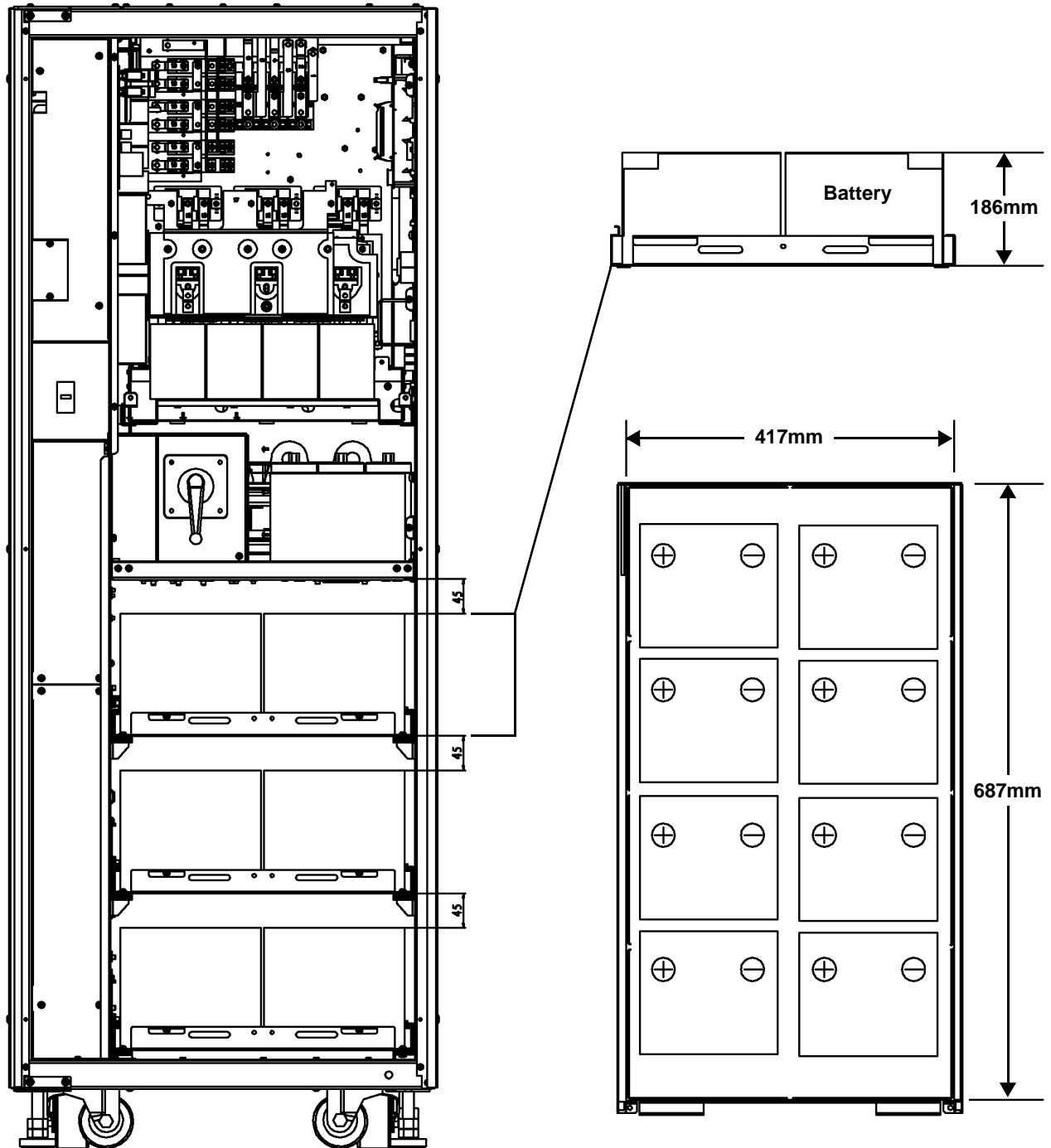

Figure 35 Battery connections

DYNASTY BATTERY

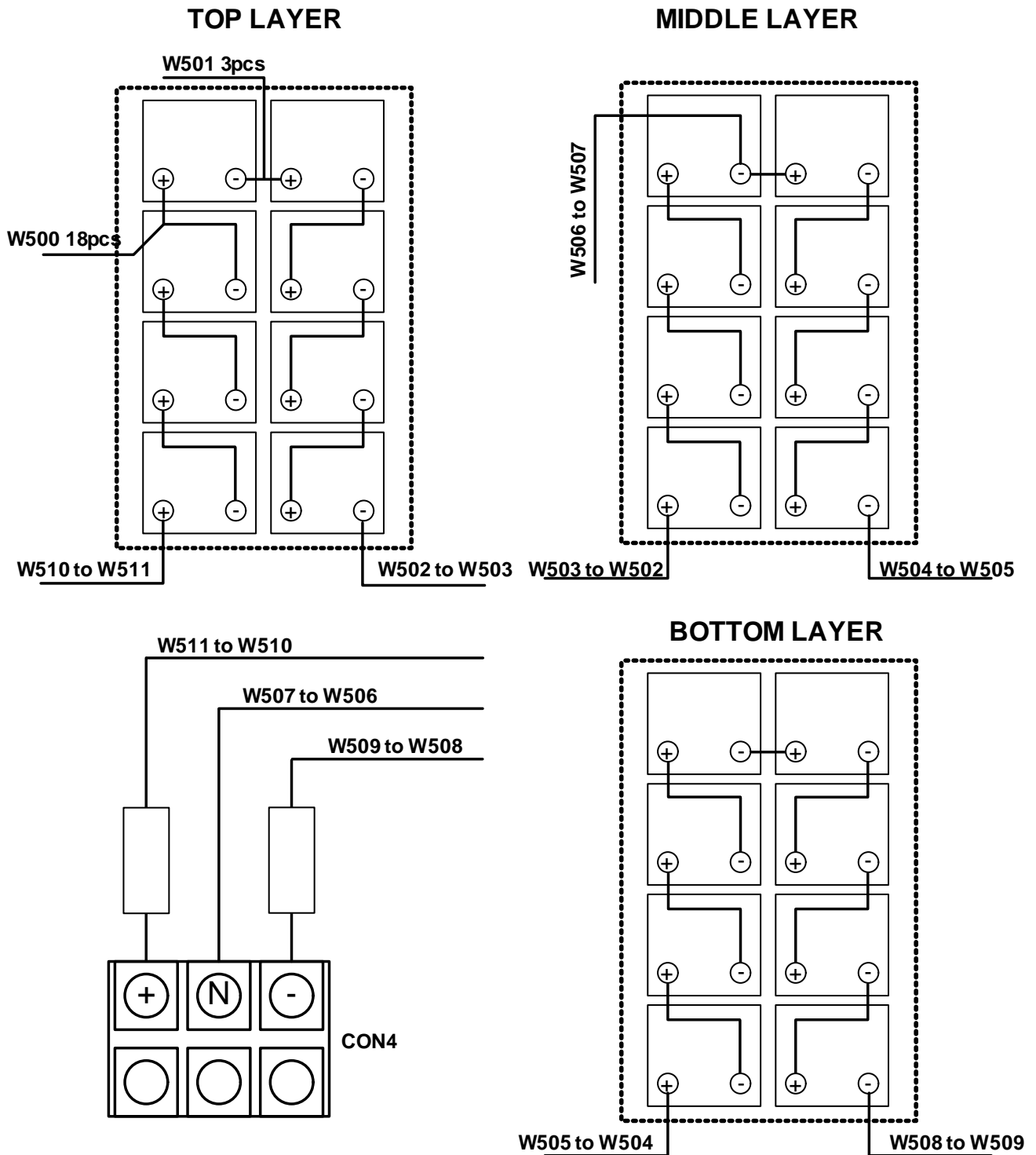
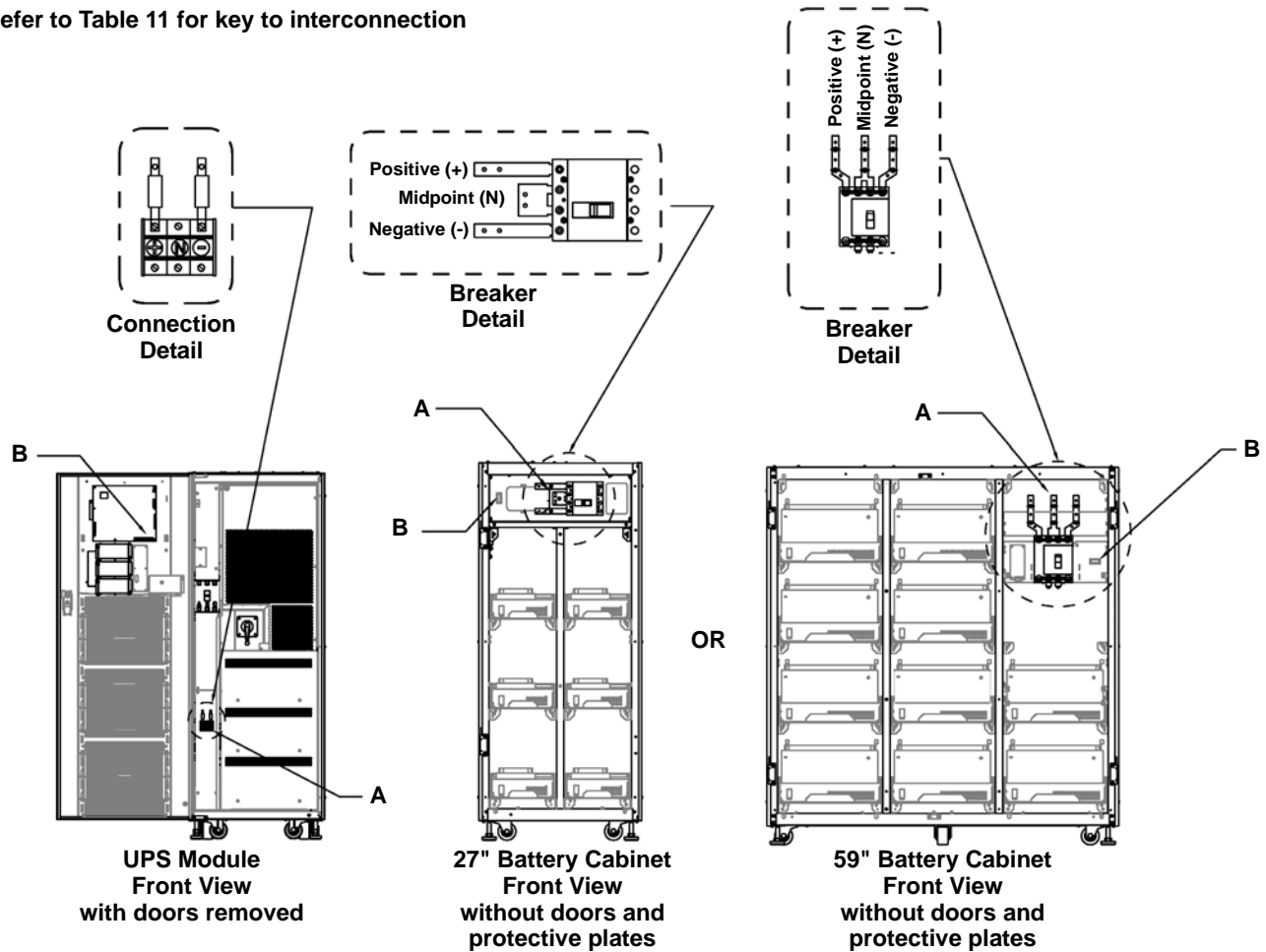

Figure 36 Battery cabinet interconnection

Refer to Table 11 for key to interconnection



NOTES:

1. All Dual-Lite-supplied cable must be repositioned prior to and while the cabinets are being placed in their final installed location.
2. All interconnection hardware supplied by Dual-Lite.
3. All interconnection cables supplied by Dual-Lite when bolted together.
4. Interconnection cables field-supplied when battery cabinets are stand-alone.
5. Refer to the individual drawing of each piece of equipment for additional details.

Table 11 Dual-Lite-supplied interconnect wiring

Run	From	To	Conductors
A	UPS battery terminal block	External 27" or 59" battery cabinet	Positive, midpoint, negative
B	Battery cabinet terminal block	UPS monitor board	Battery breaker aux contacts

Figure 37 Maintenance Bypass interconnection

Refer to Table 12 for key to interconnection

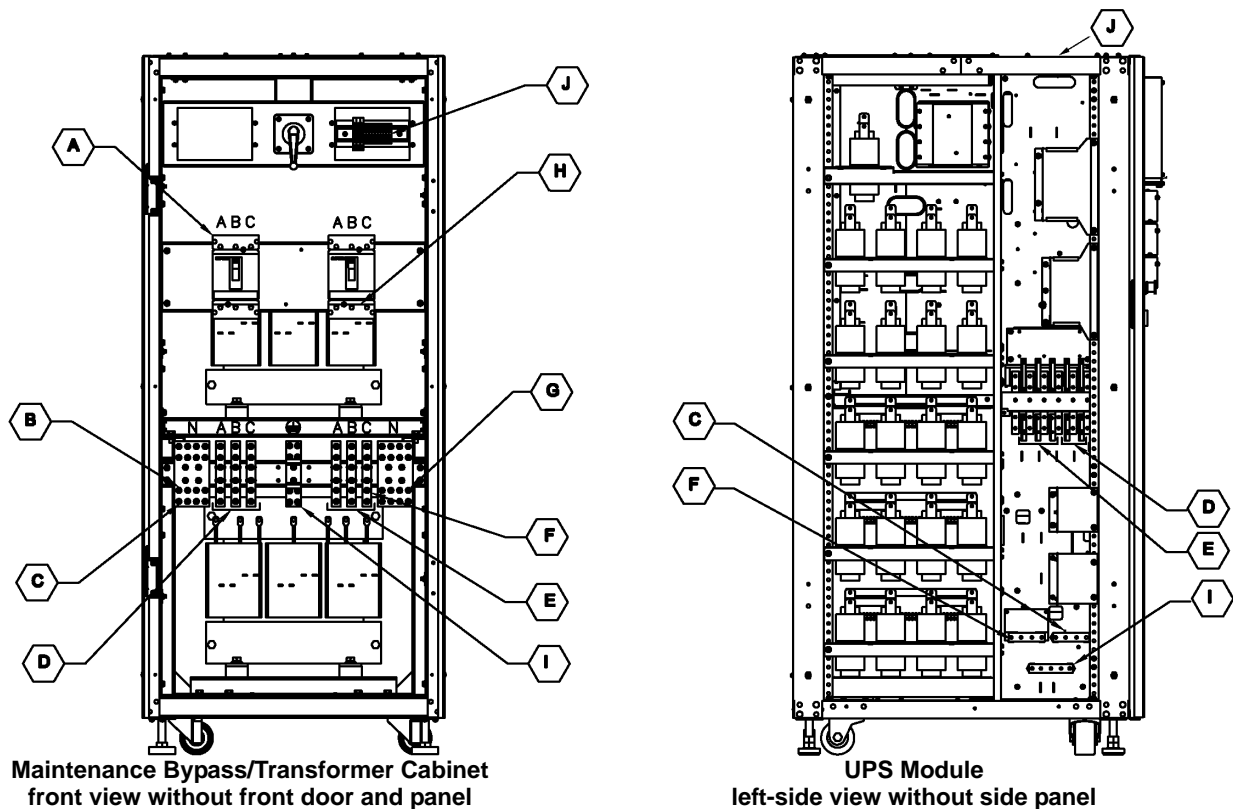

NOTES

1. All Dual-Lite-supplied cable must be repositioned prior to and while the cabinets are being placed in their final installed location.
2. All interconnection hardware supplied by Dual-Lite.
3. AC connections must be made to the UPS module before attaching maintenance bypass/transformer cabinet to UPS module.
4. Utility AC source neutral not required for maintenance bypass/transformer cabinet types D, E, M, N.
5. All cabling will be field-supplied when maintenance bypass/transformer cabinet is configured as stand-alone cabinet.
6. Maintenance bypass/transformer cabinets must attach to the left side only.
7. Refer to the individual drawing of each piece of equipment for additional details.

Table 12 Dual-Lite-supplied interconnect wiring for Maintenance Bypass Cabinet

Run	From	To	Conductors
A	Utility AC source	Maintenance	Ph A, B, C bypass/ transformer cabinet
B	Utility AC source	Maintenance	Neutral bypass/ transformer cabinet
C	Maintenance	UPS module AC input	Neutral - UPS Input
D	Maintenance	UPS module AC input	Ph A, B, C - UPS Input
E	UPS module AC output	Maintenance	Ph A, B, C - UPS Output
F	UPS module AC output	Maintenance	Neutral - UPS Output
G	Maintenance	Load AC connection	Neutral bypass cabinet
H	Maintenance	Load AC connection	Ph A, B, C bypass cabinet
I	Utility AC source	All ground connections	Ground
J	Monitoring terminal block	UPS Parallel Logic Board (M3)	Bypass contacts

Figure 38 TRX 1+1 parallel cabinet interconnections

1+1 Parallel Cabinet
(Front View Without Front Door and Panel)

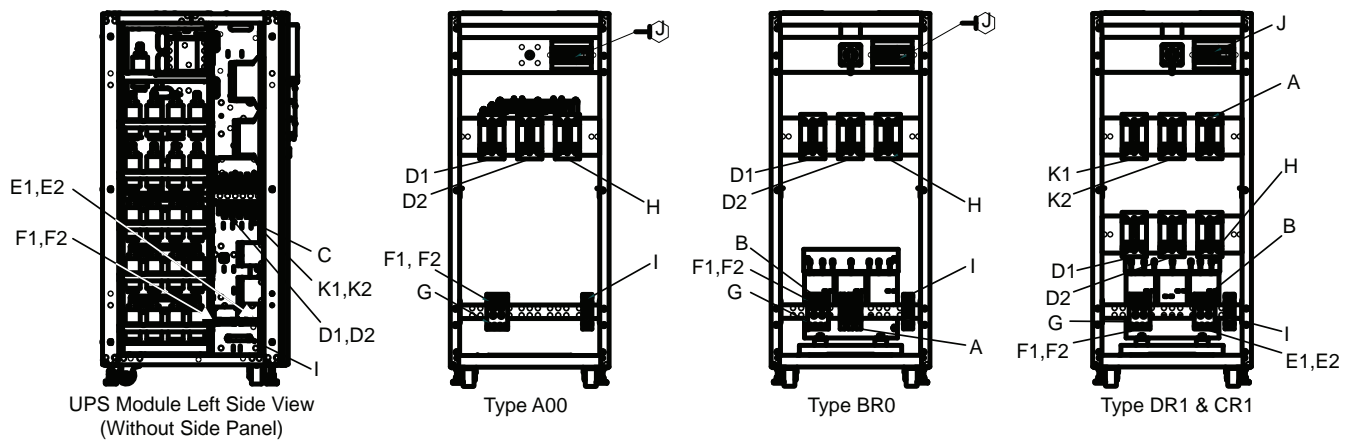

NOTES:

1. All Dual-Lite-supplied cable will need to be repositioned prior to and while setting the cabinets in their installed location.
2. All interconnection cable and hardware supplied by others.
3. AC connections must be made to the UPS modules before attaching paralleling cabinet to UPS modules.
4. Utility AC source neutral not required for maintenance bypass/transformer cabinet type CR1.
5. Paralleling cabinets must be between both UPS modules.
6. Refer to the individual drawing of each piece of equipment for additional details

Table 13 Dual-Lite-supplied interconnect wiring

Run	From	To	Conductors	Cabinet Type
A	Utility AC Source	Paralleling Cabinet	PH A, B, C - Bypass	BR0, CR1, DR1
B	Utility AC Source	Paralleling Cabinet	Neutral - Bypass	BR0, CR1, DR1
C	Utility AC Source	UPS Module AC Input	PH A,B,C - UPS	A00, BR0
D1	UPS #1 Module AC Output	Paralleling Cabinet	PH A, B, C - UPS	A00, BR0, CR1, DR1
D2	UPS #2 Module AC Output	Paralleling Cabinet	PH A, B, C - UPS	A00, BR0, CR1, DR1
E	Utility AC Source	UPS #1 Module AC Input	Neutral - UPS Input	A00, BR0, CR1, DR1
E2	Utility AC Source	UPS #1 Module AC Input	Neutral - UPS Input	A00, BR0, CR1, DR1
F1	Paralleling Cabinet	UPS #1 Module AC Output	Neutral - UPS Output	A00, BR0, CR1, DR1
F2	Paralleling Cabinet	UPS #1 Module AC Output	Neutral - UPS Output	A00, BR0, CR1, DR1
G	Paralleling Cabinet	Load AC Connection	Neutral - Load	A00, BR0, CR1, DR1
H	Paralleling Cabinet	Load AC Connection	PH A, B, C - Load	A00, BR0, CR1, DR1
I	Utility AC Source	All Ground Connections	Ground	A00, BR0, CR1, DR1
J	Monitoring Terminal Block	UPS Parallel Logic Board (M3)	Auxiliary Contacts	A00, BR0, CR1, DR1
K1	UPS #1 Module AC Input	Paralleling Cabinet	PH A, B, C - UPS	CR1, DR1
K2	UPS #1 Module AC INPUT	Paralleling Cabinet	PH A, B, C - UPS	CR1, DR1

Figure 39 Lineup detail—SlimLine distribution cabinet to TRX

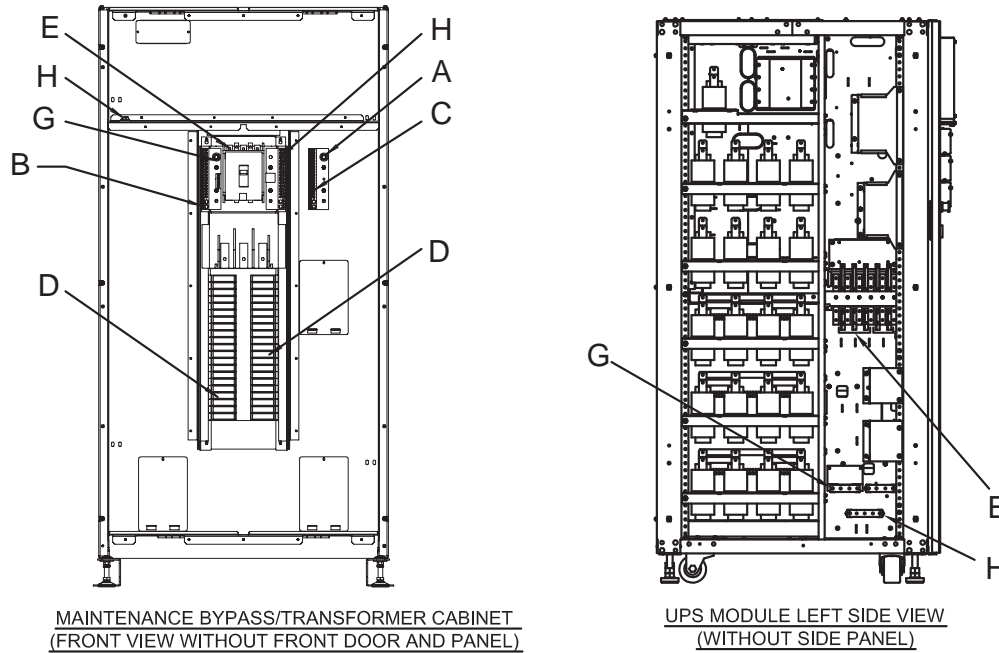

NOTES:

1. All Dual-Lite-supplied cable will need to be repositioned prior to and while setting the cabinets in their installed location.
2. All interconnection cables and hardware supplied by Dual-Lite.
3. AC connections must be made to the UPS module before attaching.
4. See **Figure 43** for placement of distribution cabinet.
5. Refer to the individual drawing of each piece of equipment for additional details.

Table 14 Dual-Lite-supplied interconnect wiring—SlimLine distribution cabinet to TRX

Run	From	To	Conductors
A	Distribution Cabinet	Load AC Connection	Isolated Ground
B	Distribution Cabinet	Load AC Connection	Neutral Distribution Cabinet
C	Distribution Cabinet	Load AC Connection	Ground Distribution Cabinet
D	Distribution Cabinet	Load AC Connection	PH A,B,C
E	UPS Module AC Output	Distribution Cabinet	PH A, B, C
G	UPS Module AC Output	Distribution Cabinet	Neutral
H	UPS Module AC Output	All Ground Connections	Ground

Figure 40 Lineup detail—1+N Type A connection to TRX

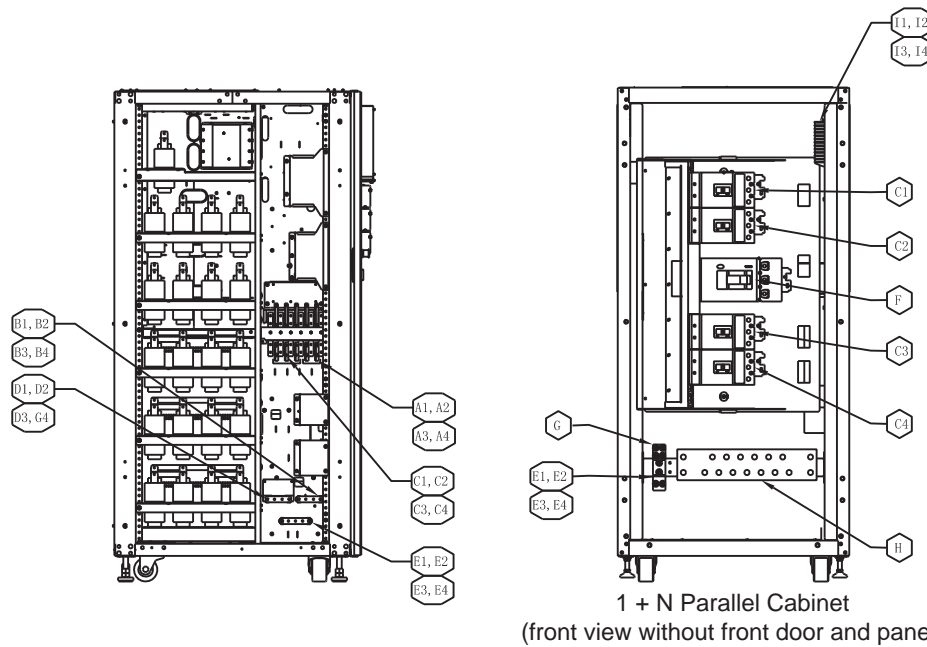

1. All Dual-Lite-supplied cable must be repositioned prior to and while setting the cabinets in their installed location.
2. All interconnection cables and hardware supplied by others.
3. AC connections must be made to the UPS modules before attaching paralleling cabinet to UPS modules
4. The interconnecting output cables between the paralleling cabinet and the UPSs must be the same size and the same length.
5. The location of the system output neutral busbar (connection K) and the ground busbar (connections H, I and J) are shown for a left-access style. For right-access version, these busbars are at opposite locations
6. Refer to the individual drawing of each piece of equipment for additional details.

Table 15 Interconnect wiring—1+N Type A connection to TRX

RUN	FROM	TO	CONDUCTORS
A1-A4	Utility AC Source	UPS #1-UPS #4 Module AC Input	Ph A, B, C - UPS Input
B1-B4	Utility AC Source	UPS #1-UPS #4 Module AC Input	Neutral - UPS Input
C1-C4	UPS #1-UPS #4 Module AC Output	Paralleling Cabinet	Ph A, B, C- UPS Output
D1-D4	UPS #1-UPS #4 Module AC Output	Paralleling Cabinet	Neutral - UPS Output
E1-E4	Paralleling Cabinet	UPS #1-UPS #4 Module AC Ground	Ground-UPS
F	Paralleling Cabinet	Load AC Connection	Ph A, B, C - Load
G	Paralleling Cabinet	Load AC Connection	Ground-Load
H	Paralleling Cabinet	Load AC Connection	Neutral-Load
I1-I4	Paralleling Cabinet	UPS #1-UPS #4 Module Parallel Logic Board (M3)	Output Breaker Aux Contact

Figure 41 Lineup detail—1+N Type B1 connection to TRX

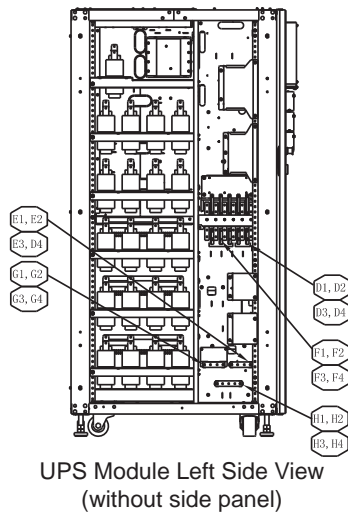
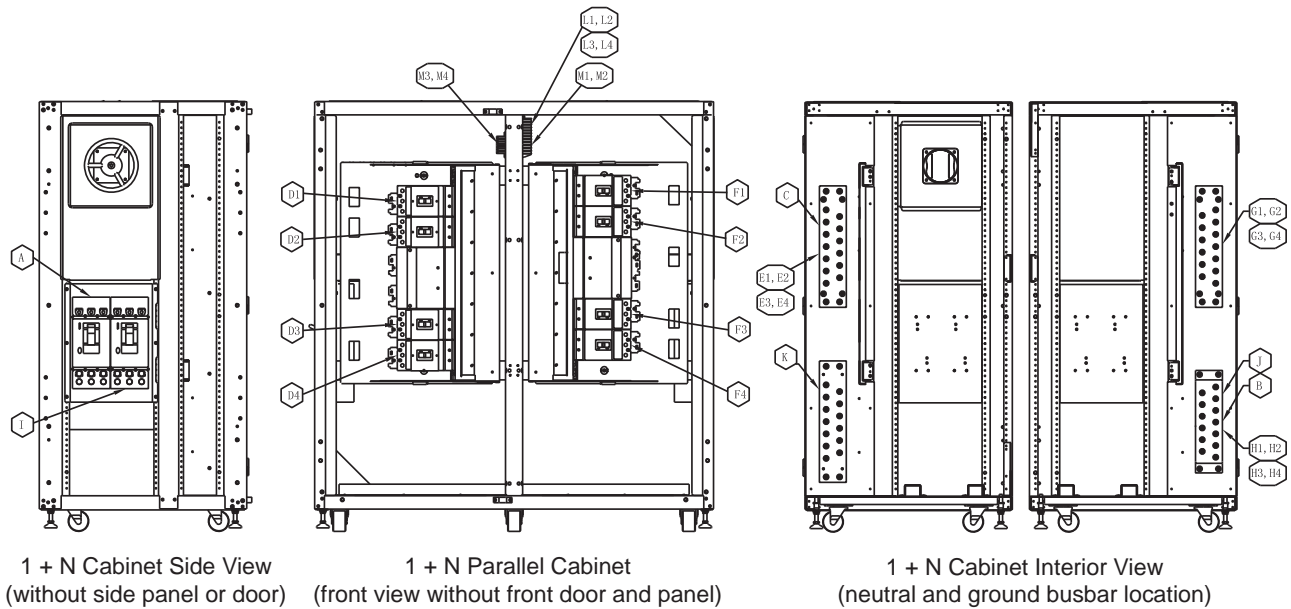

1. All Dual-Lite-supplied cable must be repositioned prior to and while setting the cabinets in their installed location.
2. All interconnection cables and hardware supplied by others.
3. AC connections must be made to the UPS modules before attaching paralleling cabinet to UPS modules.
4. The interconnecting input cables between the paralleling cabinet and the UPSs must be the same size and the same length.
5. The interconnecting output cables between the paralleling cabinet and the UPSs must be the same size and the same length.
6. The location of the system output neutral busbar (connection K) and the ground busbar (connections H, I and J) are shown for a left-access style. For right-access version, these busbars are at opposite locations.
7. Refer to the individual drawing of each piece of equipment for additional details.

Table 16 Interconnect wiring—1+N Type B1 connection to TRX

Run	From	To	Conductors
A	Utility AC Source	Paralleling Cabinet	Ph A, B, C - System Input
B	Utility AC Source	Paralleling Cabinet	Ground - System Input
C	Utility AC Source	Paralleling Cabinet	Neutral -system Input
D1-D4	Paralleling Cabinet	UPS #1-UPS #4 Module AC Input	Ph A, B, C - UPS Input
E1-E4	Paralleling Cabinet	UPS #1-UPS #4 Module AC Input	Neutral - UPS Input
F1-F4	UPS #1-UPS #4 Module AC Output	Paralleling Cabinet	Ph A, B, C - UPS Output
G1-G4	UPS #1-UPS #4 Module AC Output	Paralleling Cabinet	Neutral - UPS Output
H1-H4	Paralleling Cabinet	UPS #1-UPS #4 Module AC Ground	Ground-UPS
I	Paralleling Cabinet	Load AC Connection	Ph A, B, C - Load
J	Paralleling Cabinet	Load AC Connection	Ground-load
K	Paralleling Cabinet	Load AC Connection	Neutral-Load
L1-L4	Paralleling Cabinet	UPS #1-UPS #4 Module UPS Parallel Logic Board (M3)	Output Breaker Aux Contact
M1-M4	Paralleling Cabinet	UPS #1-UPS #4 Module UPS Parallel Logic Board (M3)	Rotary Switch Aux Contact

Figure 42 Lineup detail—1+N Type C connection to TRX

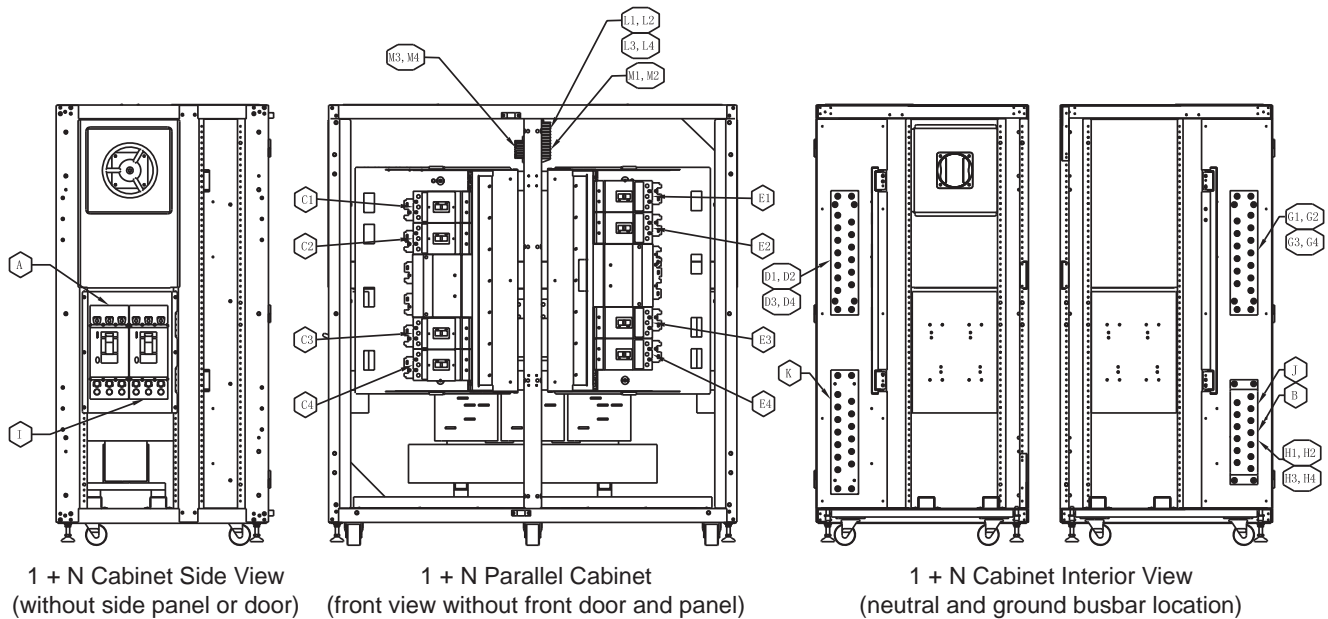

1. All Dual-Lite-supplied cable must be repositioned prior to and while setting the cabinets in their installed location.
2. All interconnection cables and hardware supplied by others.
3. AC connections must be made to the UPS modules before attaching paralleling cabinet to UPS modules.
4. Utility AC source neutral not required for maintenance bypass/transformer cabinet Type C.
5. The interconnecting input cables between the paralleling cabinet and the UPSs must be the same size and the same length.
6. The interconnecting output cables between the paralleling cabinet and the UPSs must be the same size and the same length.
7. The location of the system output neutral busbar (connection K) and the ground busbar (connections H, I and J) are shown for a left-access style. For right-access version, these busbars are at opposite locations.
8. Refer to the individual drawing of each piece of equipment for additional details.

Table 17 Interconnect wiring—1+N Type C connection to TRX

Run	From	To	Conductors
A	Utility AC Source	Paralleling Cabinet	Ph A, B, C-system Input
B	Utility AC Source	Paralleling Cabinet	Ground - System Input
C1-C4	Paralleling Cabinet	UPS #1-UPS #4 Module AC Input	Ph A,B, C - UPS Input
D1-d4	Paralleling Cabinet	UPS #1-UPS #4 Module AC Input	Neutral - UPS Input
E1-E4	UPS #1-UPS #4 Module AC Output	Paralleling Cabinet	Ph A, B, C - UPS Output
G1-G4	UPS #1-UPS #4 Module AC Output	Paralleling Cabinet	Neutral - UPS Output
H1-H4	Paralleling Cabinet	UPS #1-UPS #4 Module AC Ground	Ground - UPS
I	Paralleling Cabinet	Load AC Connection	Ph A,B, C - Load
J	Paralleling Cabinet	Load AC Connection	Ground - Load
K	Paralleling Cabinet	Load AC Connection	Neutral - Load
L1-I4	Paralleling Cabinet	UPS #1-UPS #4 Module UPS Parallel Logic Board (M3)	Output Breaker Aux Contact
M1-M4	Paralleling Cabinet	UPS #1-UPS #4 Module UPS Parallel Logic Board (M3)	Rotary Switch Aux Contact

Figure 43 Suggested placement—single TRX with auxiliary cabinets

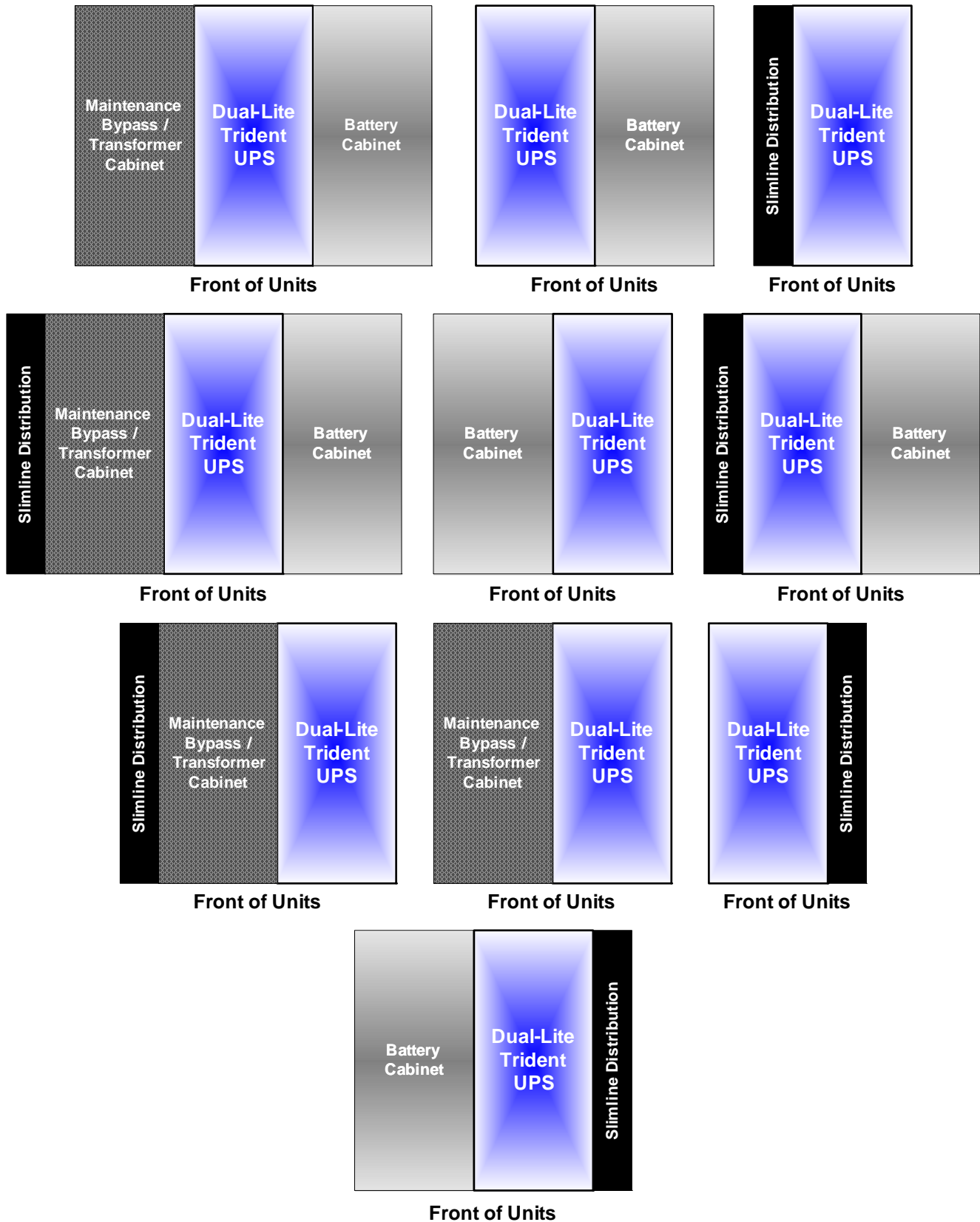
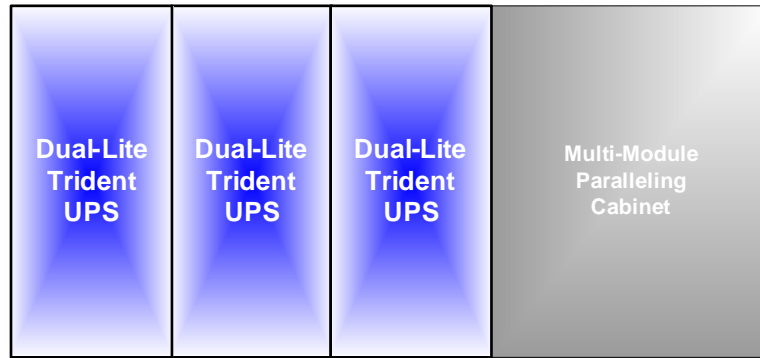
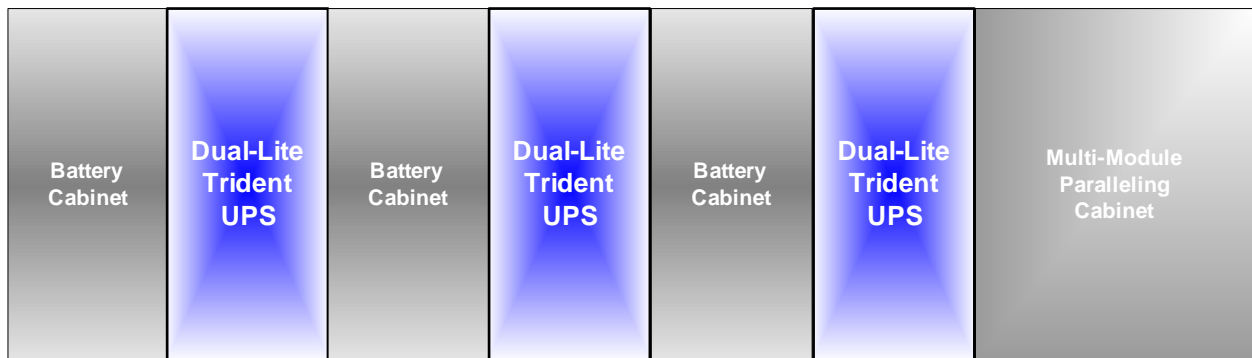

Figure 44 Suggested placement, multiple TRX units with auxiliary cabinets



Front of Units



Front of Units

7.0 OPERATION

7.1 General Description

The standard TRX consists of the UPS and internal batteries in a compact, single cabinet.

As shown in **Figure 45**, the AC utility source is input at CB1 and the rectifier converts the AC utility into DC power. The inverter converts that DC power from the utility—or DC power from the batteries—into AC power for the load. The batteries power the load through the inverter in the event of a power failure. The utility source can also power the load through the static bypass.

If maintenance or repair of the UPS is necessary, the load can be switched without interruption in service to the maintenance bypass.

Figure 45 Single module block diagram (dual input configuration)

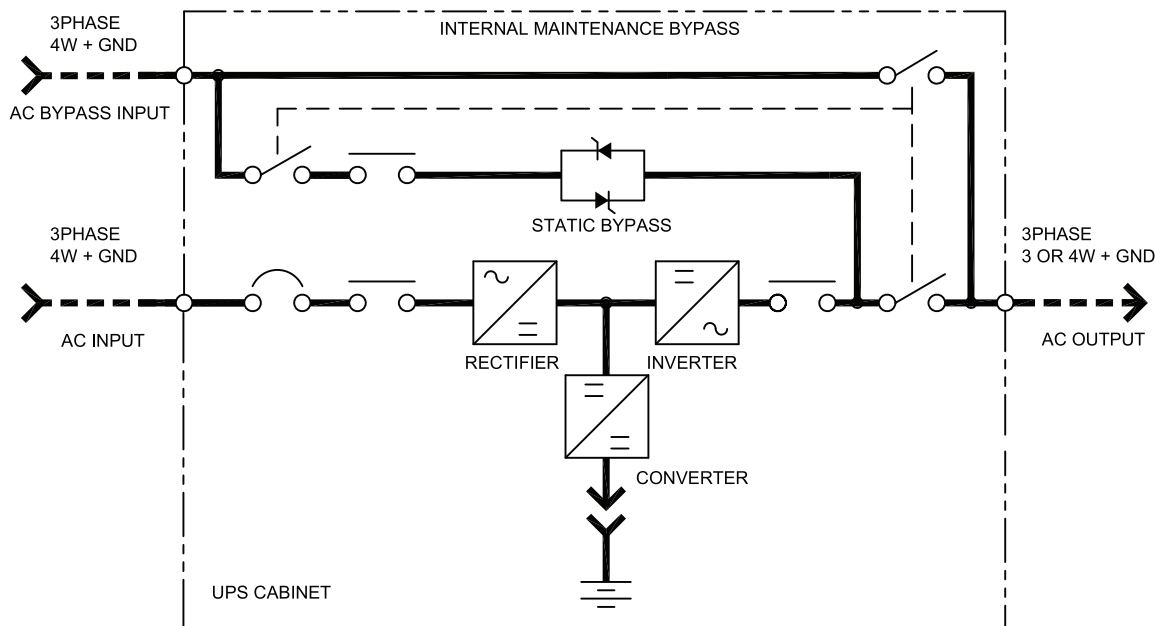

7.2 Bypass Supplies

The circuit block labeled “Static Switch” and “Contactor” in **Figure 45** contains an electronically controlled switching circuit that enables the critical load to be connected to either the inverter output or to a bypass power source via the static bypass line. During normal system operation the load is connected to the inverter and the inverter contactor is closed; but in the event of a UPS overload or inverter failure, the load is automatically transferred to the static bypass line.

To provide a clean (no-break) load transfer between the inverter output and static bypass line, the static switch activates, connecting the load to bypass. To achieve this, the inverter output and bypass supply must be fully synchronized during normal operating conditions. This is achieved through the inverter control electronics, which make the inverter frequency track that of the static bypass supply, provided that the bypass remains within an acceptable frequency window.

A manually controlled, maintenance bypass supply is incorporated into the UPS design. It enables the critical load to be powered from the utility (bypass) supply while the UPS is shut down for routine maintenance.



NOTE

When the UPS is operating in bypass mode or on maintenance bypass, the connected equipment is not protected from power failures or surges and sags.

7.3 Operating Modes

The UPS is designed to operate as an on-line, double-conversion, reverse-transfer system in the following modes:

Normal Mode

Operating in normal mode, the TRX's rectifier derives power from a utility AC source and supplies regulated DC power to the inverter, which regenerates precise AC power to supply the connected equipment. The rectifier also uses the utility source power to charge the batteries.

Battery Mode

When utility AC power fails, the TRX protects the critical load by instantaneously channeling battery power to the inverter which continues supporting the critical load without interruption. When utility power returns and is within acceptable limits, the TRX automatically shifts back to Normal mode, with the rectifier powering the critical load.

Bypass Mode

When the TRX is in bypass mode, the load is directly supported by utility power and is without battery backup protection.

The TRX's static transfer switch will shift the load from the inverter to bypass mode without an interruption in AC power if the inverter is synchronous with the bypass and any of the following occurs:

- inverter fails
- inverter overload capacity is exceeded
- inverter is manually turned off by user



NOTE

If the inverter is asynchronous with the bypass, the static switch will transfer the load from the inverter to the bypass WITH interruption in AC power to the critical load. This interruption will be less than 15ms (in 50Hz), or less than 13.33ms (in 60Hz). This interruption time may be altered by modifying the Output transfer interrupt time setting.

Maintenance Mode

For maintenance or repair, the TRX may be operated in maintenance mode. To place the TRX in maintenance mode, the load must be transferred to bypass and the inverter must be turned off. When those conditions are met, the rotary switch may be turned to MAINT and the UPS may be shut down, permitting disconnecting the batteries for maintenance.



CAUTION

The internal maintenance bypass must not be used when the UPS system is in 1+N parallel.



WARNING

The UPS input and output must be protected with external overcurrent protection devices. In maintenance mode, the input and output busbars remain energized.

Parallel Redundancy Mode (System Expansion)

For higher capacity, higher reliability or both, the outputs of up to four UPS modules can be programmed for directly paralleling while a built-in parallel controller in each UPS ensures automatic load sharing.

Frequency Converter Mode

The Dual-Lite TRX can be programmed into frequency converter mode for either 50Hz or 60Hz stable output frequency. The input frequency may vary from 40Hz to 70Hz. In this mode, the static bypass operation is disabled and the battery becomes optional, depending on any requirement to operate in battery mode (stored energy mode).

8.0 OPERATOR CONTROL AND DISPLAY PANEL

8.1 Operator Control Panel

The control panel and LCD on the front of the Dual-Lite TRX lets the operator:

- turn the UPS on or off
- transfer into the various operating modes
- silence alarms
- check the status of the UPS and its batteries, including all measured parameters, events and alarms

The main areas of the control panel are shown below in **Figure 46** and detailed in **Figure 47**.

- **Mimic Display** - view the status of the TRX in single-line diagram format—indicators show status by changing color when ON, flashing or OFF
- **Liquid Crystal Display (LCD) and Navigation keys** - view status and operational data from the TRX in tabular format
- **Control buttons** - turn the TRX on or off, silence alarms

Figure 46 Overview of control panel

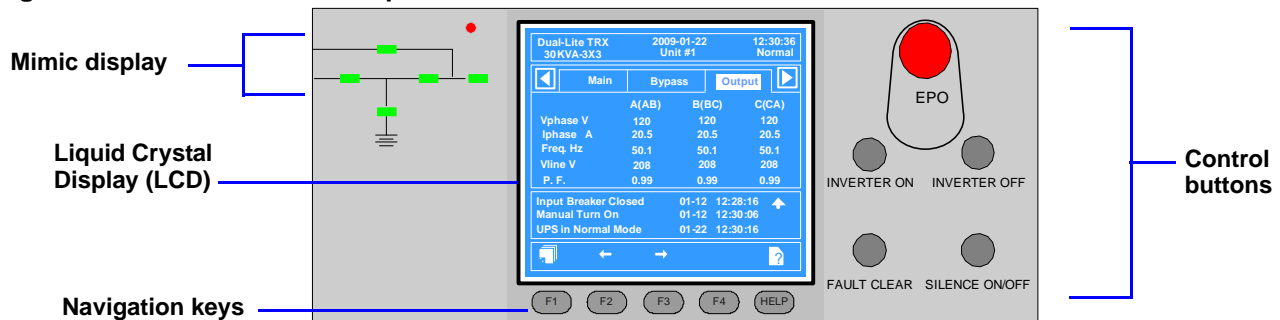

8.1.1 Display Panel Layout

Figure 47 shows the control panel in greater detail, identifying individual items that are described in the rest of this section.

Figure 47 Detailed view of control panel

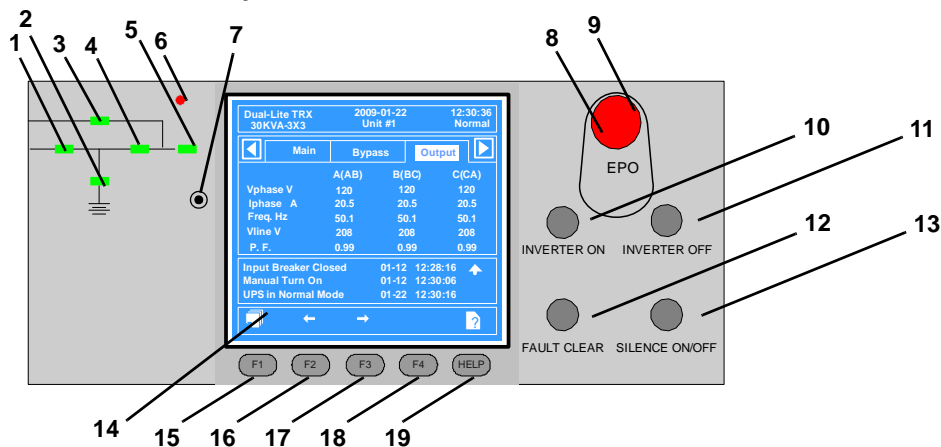

Mimic indicators	Control buttons	Navigation keys
1. Rectifier indicator	8. Button cover	15. F1
2. Battery indicator	9. EPO button	16. F2
3. Bypass indicator	10. INVERTER ON button	17. F3
4. Inverter indicator	11. INVERTER OFF button	18. F4
5. Load indicator	12. FAULT CLEAR button	19. Help
6. Status indicator	13. SILENCE ON/OFF button	
7. Buzzer	14. LCD	

8.2 Mimic Display Indicators

The Mimic display on the front panel consists of six indicators arranged in a single-line diagram depicting the various paths of UPS power, as shown in **Figure 48**.

Figure 48 Mimic display indicators location

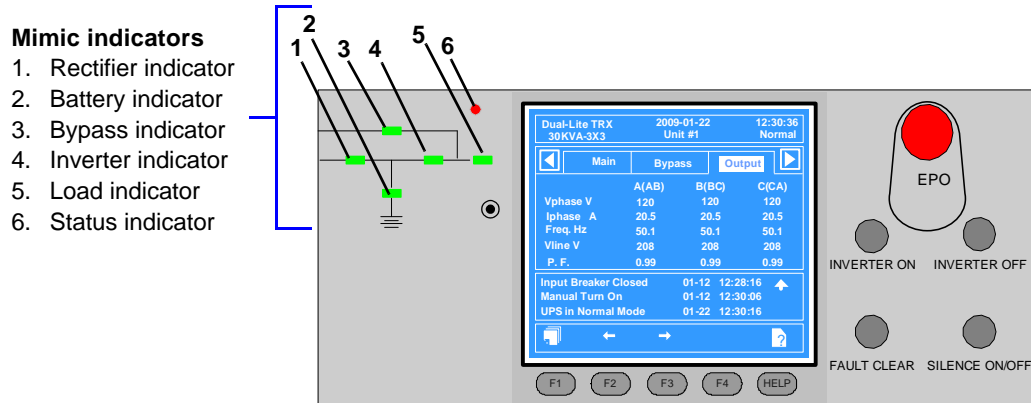

The current operational status of the Dual-Lite TRX is indicated by the color of the indicators—green, amber or red—and whether they are ON (solid), flashing or OFF. **Table 18** provides a guide to interpreting the various states of the indicators.

Table 18 Mimic display status indicators

Indicator (see Figure 48)	Green	Flashing Green / Amber	Red	Off
1. Rectifier	Load on rectifier	Flashing Green: Utility normal, but rectifier not operating	Rectifier fault	Rectifier is normal, but utility is abnormal
2. Battery	Battery powering the load	Flashing Green: Battery pre-warning (low battery)	Battery or battery converter abnormal*	Battery and converter are normal, and battery is not discharging
3. Bypass	Load on Bypass power	—	Bypass out of normal range	Bypass Normal
4. Inverter	Inverter powering the load normally	Flashing Green: Inverter on standby	Inverter fault	Inverter normal, but off
5. Load	UPS output on	—	UPS output overloaded	UPS no output power
6. Status	No alarms—UPS working normally	Amber: UPS has a general alarm	UPS has a serious alarm	—

* Battery or battery converter abnormal events include these event messages (see **Table 44** in **Appendix A**): No Battery, Battery Replaced, Battery Reverse, Batt. Conv. Over. Curr., Batt. Converter Fault, Batt. Converter Overtemp.

8.3 Control Buttons

The **Control Buttons** on the front panel may be used to shut down the UPS completely, turn the inverter on or off, restart the UPS after a fault and silence the alarm, as shown in **Figure 49**. The function of each button is described in **Table 19**.



NOTE

To activate a button properly, press and hold until you hear a short beep—about two seconds.

Figure 49 Location of control buttons

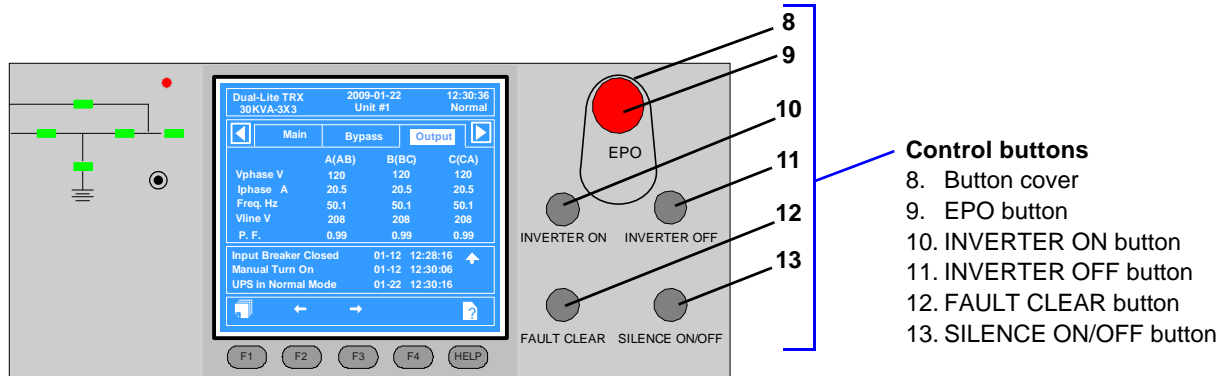

Table 19 Control buttons

Button (see Figure 49)	Function
EPO	Completely shuts down the UPS, including the static switch. CAUTION: Use caution before pressing the Emergency Power Off (EPO) button. This button completely shuts down the unit and the critical load.
INVERTER ON	Press this button to start the inverter and transfer from static bypass to inverter. NOTE: If the inverter is not ready, this will not activate the UPS.
INVERTER OFF	Press this button to shut down the inverter during operation. The load will be transferred to static bypass.
FAULT CLEAR	After the UPS shuts down due to a fault and the alarm condition has been resolved, press this button to clear the fault and restart the UPS.
SILENCE ON/OFF	Press this button once to silence the alarm buzzer when an alarm is active. Any new fault will sound the buzzer again. If the alarm buzzer is not beeping, press this button to test the alarm sound.

8.4 Alarm Buzzer

The alarm buzzer produces three types of sounds:

- **Single beep** - when any Control button is pressed
- **Single beep repeating every two seconds** - the system has a general alarm
- **Continuous** - the system has a serious fault

If the alarm buzzer makes no sound, the system may be operating properly or the alarm may have been silenced manually.

Figure 50 Alarm buzzer location

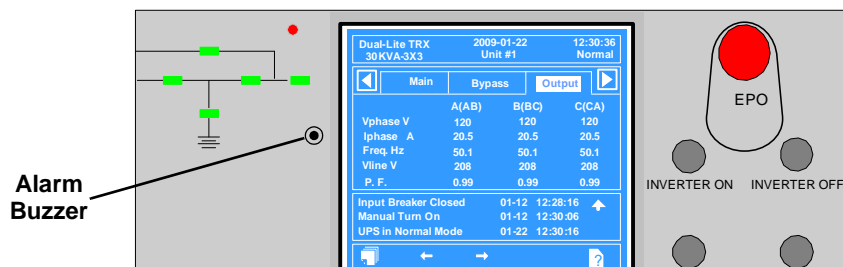

8.5 LCD Overview

The LCD on the front panel has five main sections, as shown in **Figure 51**. Press the F1 key below the LCD to scroll through these sections.

- **UPS system information** - view UPS name and model, date and time, overall status (see **Table 21**).
- **LCD Menu** - choose a category of data items to appear below the menus (see **Table 22**).
- **Data and settings** - view data items for the selected menu (see **Table 22**).
- **Current status messages** - check the most recent UPS event and alarm messages (see **Table 44** in **Appendix A**).
- **Navigation key icons** - look at the icon above each navigation key to determine how the key operates when pressed (see **8.6 - Navigation Keys**).

The LCD displays alarm information in real time. After appearing in the current status section of the LCD, status messages are stored in the history log—512 records can be stored and retrieved.

Figure 51 Sections of the LCD

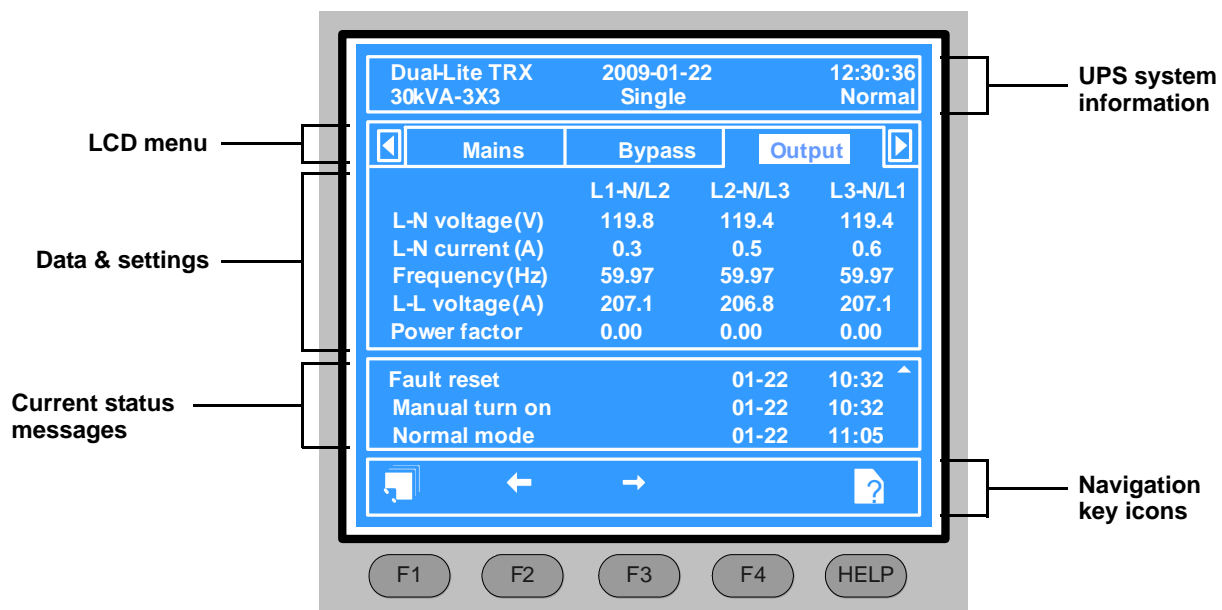







8.6 Navigation Keys

The navigation keys on the front panel—F1 through F4 and Help—are used to access the LCD to view the current status and other information about the TRX.

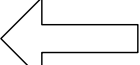
Navigation key icons on the LCD appear above each key to indicate its operation (see **Table 20**). The keys are “soft keys” that can change functions according to the icon.

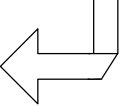
- Use **F1** either to move to a different portion of the LCD (shift icon) or to escape to a previous view (ESC icon).
- Use **F2** and **F3** as cursor keys to move left and right or up and down, depending on the icons displayed above the keys.
- Use **F4** as an Enter key to confirm a choice.
- Use **HELP** to access help information on the LCD.

Table 20 Icons for navigation keys

Key	F1	F2	F3	F4	HELP
Functions Available	 Shift	 Left	 Right	 Enter	 Help
	ESC Exit	 Up	 Down		

8.7 UPS System Information

The UPS system information displayed at the top of the LCD is detailed in **Table 21**.

Table 21 Description of items in UPS system window

No.	Item Type	Explanation
1	Dual-Lite TRX	UPS name
2	2002-10-12	Current date
3	12:30:36	Current time
4	030kVA-3x3	030 means UPS model is 30kVA; 3x3 means 3 by 3 system (three phase input and output)
5	Unit #1	#1 of 6 Paralleled changed to “Unit #1”
	Single	UPS is configured as a single-unit system running in Normal mode
6	Normal	UPS in normal operation, inverter powering load, no warnings
	Warning	UPS has a general alarm
	Fault	UPS has a serious fault

8.8 LCD Menus and Data Items

The LCD menus provide access to the following categories of information and settings for the UPS. Selecting a menu changes the information displayed in the UPS data items portion of the LCD. The menu choices are listed below and described in detail in **Table 22**.

- **Mains** - view utility power input data: voltage, current, frequency and power factor
- **TX Input** - view input transformer voltages
- **Bypass** - view bypass data: voltage and frequency
- **Output** - view output data: voltage, current, frequency and power factor
- **Load** - view load data: load percent, output current, output power and crest factor (CF)
- **System** - view system data
- **Battery** - view battery characteristics—voltage, current, temperature, remaining time and capacity—and messages when the battery is boost/float charging or disconnected
- **Records** - access the history log—displays all records in the log (newest records added at end)
- **Language** - select a language for LCD text (choices appear in the native language)
- **Settings** - configure UPS settings: adjust the display contrast, choose a format for date display, set the date and time, set up the UPS for modem communications (baud rate, address, mode and phone numbers to dial for alarm notifications) and change the password
- **Command** - start or stop a battery maintenance test, battery capacity test or system test
- **Version** - view firmware versions for the inverter, rectifier and software display board and the model information for the UPS

Figure 52 shows a menu tree of the options available from the LCD menus.

Figure 52 Menu tree

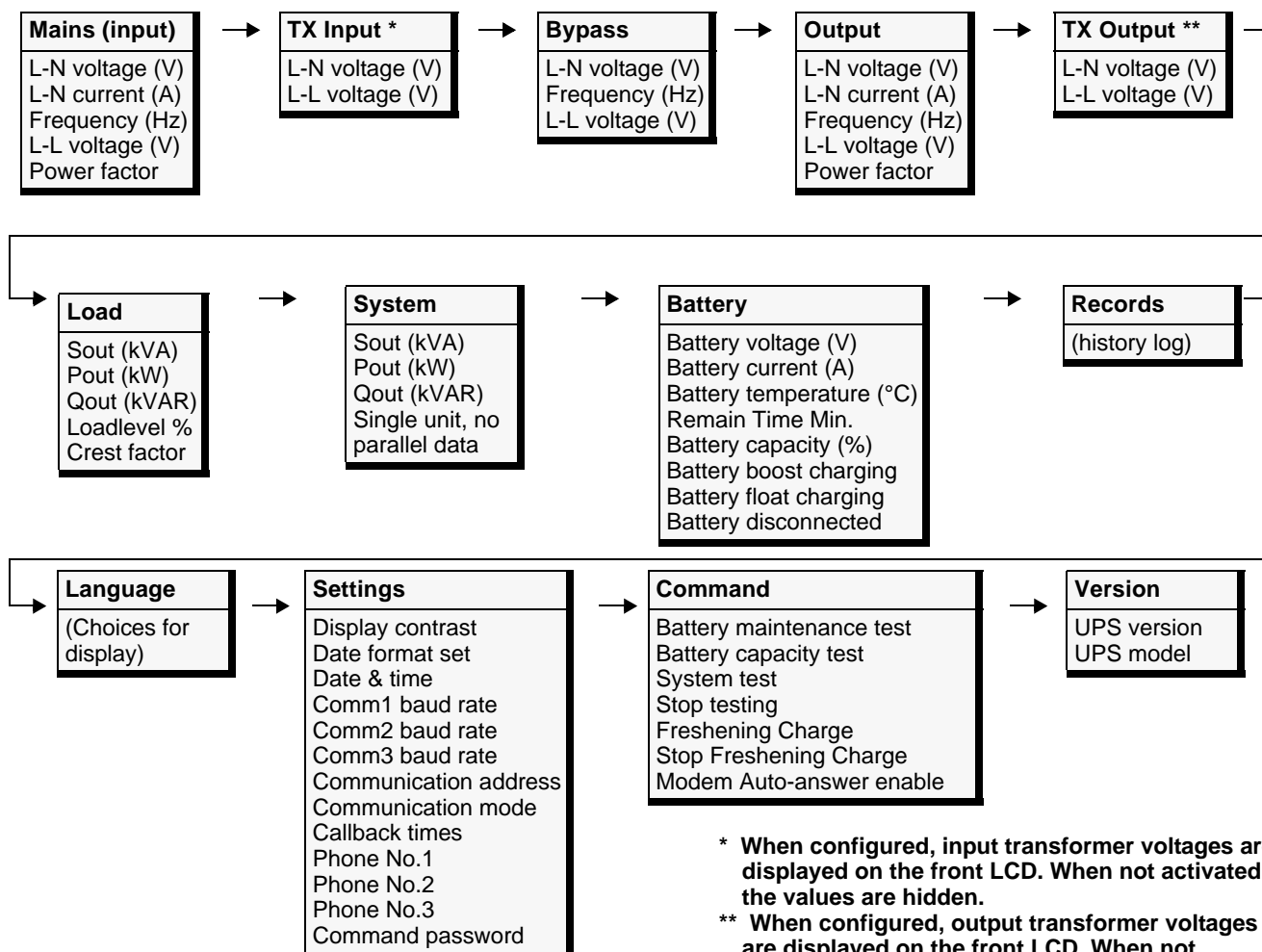

* When configured, input transformer voltages are displayed on the front LCD. When not activated, the values are hidden.

** When configured, output transformer voltages are displayed on the front LCD. When not activated, the values are hidden.

8.9 Language Selection

The LCD menus and data display are available in 12 languages (Chinese, Dutch, English, French, German, Italian, Japanese, Polish, Portuguese, Russian, Spanish and Swedish). To select a different language:

- From the main menu, press the **F1** (shift) key to move the cursor to the menu at the top of the screen.
- Press **F2** and **F3** (left and right arrows) as needed to select the **Language** menu.
- Press **F1** (shift) to move the cursor to the data and settings area of the LCD.
- Use **F2** and **F3** (up and down) to select the required language.
- Press the **F4** (enter) key to accept the language selection.
- Return to the main menu by repeatedly pressing **F1** (ESC) as needed; all text on the LCD will now be displayed in the selected language.

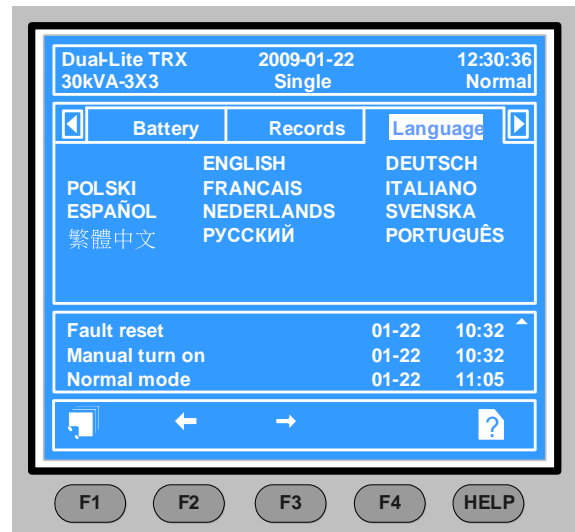

8.10 Current Date and Time

To change the system date and time:

- From the main menu, press the **F1** (shift) key to move the cursor to the menu at the top of the screen.
- Press **F2** and **F3** (left and right arrows) as needed to select the **Settings** menu.
- Press **F1** (shift) to move the cursor to the data and settings area of the LCD.
- Use **F2** and **F3** (up and down) to select the **Date & Time** option, then press **F4** (enter).
- Position the cursor on the row in which the date and time are displayed, then press **F4** (enter).
- Using the **F2** and **F3** (up and down) keys, enter the current time and date information.
- Press **F4** (enter) to save the settings, then press **F1** (ESC) to return to the main menu.



Table 22 Descriptions of UPS menus and data window items

Menu Type	Item Type	Explanation
Mains (input)	L-N voltage (V)	Phase voltage
	L-N current (A)	Phase current
	Frequency (Hz)	Input frequency
	L-L voltage (v)	Line-line voltage
	Power factor	Power factor
TX Input	L-N voltage (V)	Phase voltage
	L-L voltage (V)	Line-line voltage
Bypass	L-N voltage (V)	Phase voltage
	Frequency (Hz)	Bypass frequency
	L-L voltage (A)	Line-line voltage
Output	L-N voltage (V)	Phase voltage
	L-N current (A)	Phase current
	Frequency (Hz)	Output frequency
	L-L voltage (V)	Line-line voltage
	Power factor	Power factor
TX Output	L-N voltage (V)	Phase voltage
	L-L voltage (V)	Line-line voltage
Load	Sout (kVA)	Sout: Apparent power
	Pout (kW)	Pout: Active power
	Qout (kVAR)	Qout: Reactive power
	Loadlevel %	The percent of the UPS rating load
	Crest factor	Output current Crest Factor
System	Sout (kVA)	Sout: Apparent power
	Pout (kW)	Pout: Active power
	Qout (kVAR)	Qout: Reactive power
	Single unit, no parallel data	When configured as a single unit, UPS has only native load, no system load.
Battery	Battery voltage (V)	Battery bus voltage
	Battery current (A)	Battery bus current
	Battery temperature (°C)	Internal battery temperature °C
	Remain Time Min.	Battery run time remaining
	Battery boost charging	Battery is boost charging
	Battery float charging	Battery is float charging
	Battery disconnected	Battery is not connected
Records	(history log)	Displays all records in the history log
Language	(choices for text displayed)	User may select any of 12 languages for LCD text.

Table 22 Descriptions of UPS menus and data window items (continued)

Menu Type	Item Type	Explanation
Settings	Display contrast	Adjust the LCD display contrast
	Date format set	Choose the format for date display: M/D/Y, D/M/Y, M/D/Y, Y/M/D
	Date & time	Set the date and time
	Comm1 baud rate	Communication baud rate setting for IntelliSlot 1
	Comm2 baud rate	Communication baud rate setting for IntelliSlot 2
	Comm3 baud rate	Communication baud rate setting for IntelliSlot 3
	Communication address	This setting is applicable to RS485 communication mode
	Communication mode	Communication Mode Setting
	Callback times	When IntelliSlot 1 Communication mode is Modem, this parameter sets the number of times a number is redialed to send an alarm notification.
	Phone No.1	When IntelliSlot 1 Communication mode is Modem, this is the first phone number to be dialed (to send an alarm notification).
	Phone No.2	When IntelliSlot 1 Communication mode is Modem, this is the second phone number to be dialed (to send an alarm notification).
	Phone No.3	When IntelliSlot 1 Communication mode is Modem, this is the third phone number to be dialed (to send an alarm notification).
	Command password	User can modify the command password.
Command (start/stop battery & system tests)	Battery maintenance test	This test performs a partial discharge of the battery to obtain a rough estimate of the battery capacity. Load must be between 20% and 80%.
	Battery capacity test	This test performs a full discharge of the battery to obtain a precise measure of the battery capacity. Load must be between 20% and 80%.
	System test	This is a self-test of the UPS. When the user activates this function, a pop-up window appears about 5 seconds later to show the results.
	Stop testing	Manually stops a battery maintenance test, battery capacity test or system test.
	Freshening Charge	Allows a temporary Equalize charge for the batteries. This charge is configurable for 1 to 36 hours.
	Stop Freshening Charge	Manually stops a Freshening Charge
	Modem Auto-answer enable	Manually enable the modem's auto-answer function.
Version	UPS version	Provides UPS firmware version numbers for the inverter, rectifier and software display board.
	UPS model	Provides UPS model information—for example, 208V-60Hz.

8.11 UPS Status Messages

The TRX displays status changes as they occur in the **current status window of the LCD**, then stores that data in the **history log**, as shown in **Figure 53**.

- **Current Status Window:** The status messages are displayed chronologically and include the date and time of the events. Three status messages are visible in the window at a time. To see other messages, use the navigation keys to scroll up or down the list. A status message remains in the current status area of the LCD until the status changes, when it is moved to the history log.
- **History Log:** When a record moves to the history log, the time the status changed is recorded. The history log can hold up to 512 records. History log records may be viewed by accessing the Records menu.

Figure 53 Current status and history log records

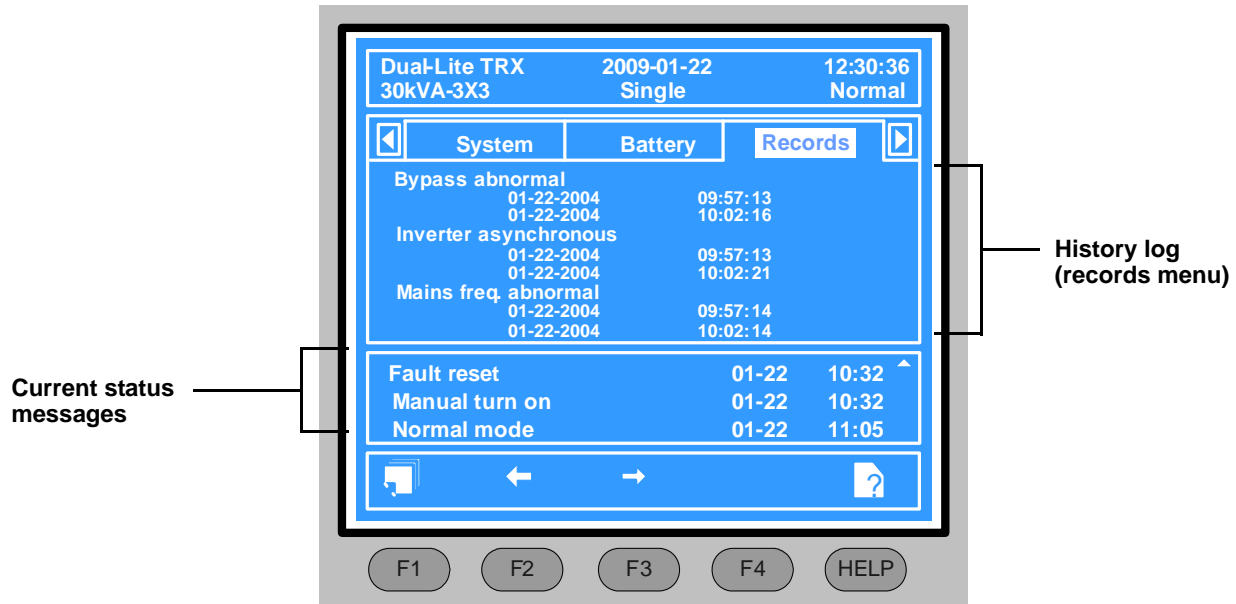

See **Table 44** in **Appendix A** for a complete list of status messages, along with a description and any recommended actions.

8.12 Types of LCD Screens

This section provides a quick guide to the main types of LCD screens.

8.12.1 Opening Display

As the UPS begins powering up, the opening display appears, as shown in **Figure 54**.

Figure 54 Opening display

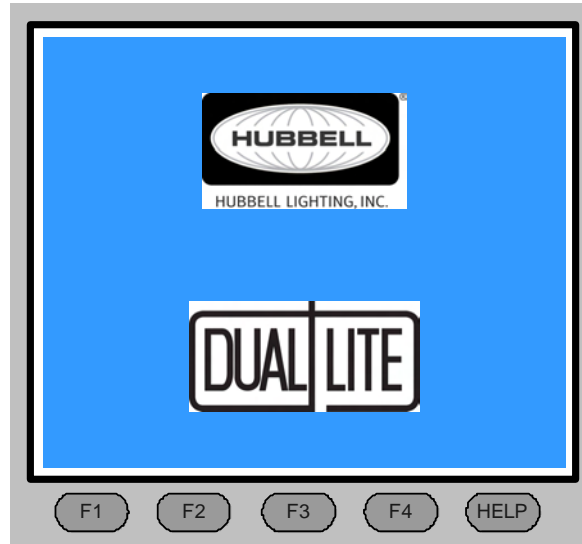

8.12.2 Default Screen

After the UPS has powered up and completed a self-test, the output screen appears, as shown in **Figure 55**. This window is the default screen.

Figure 55 Default screen

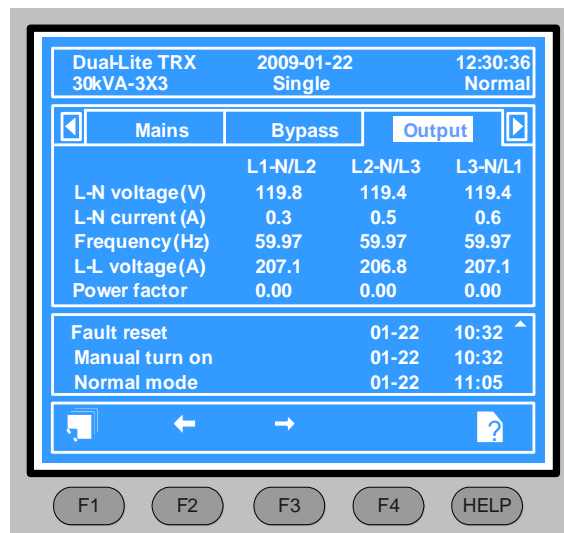

8.12.3 UPS Help Screen

Press the HELP key below the LCD to display the Help window shown in **Figure 56**. (Press the HELP key again to exit the Help window.)

Figure 56 Help screen

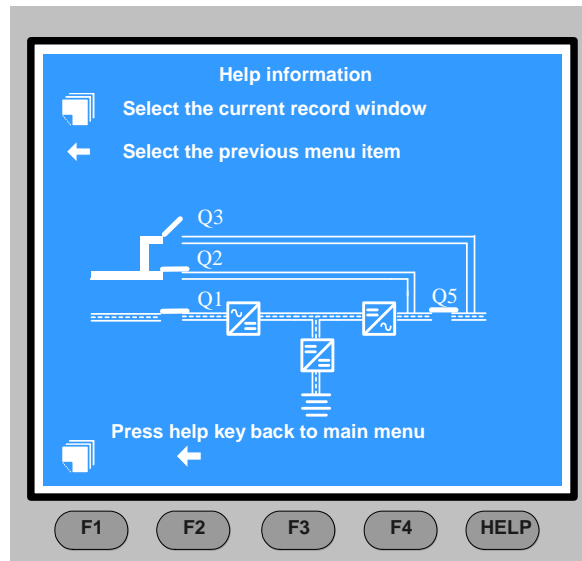

8.12.4 Screen Saver Window

If there has been no interaction with the TRX's LCD for 2 minutes, the screen saver window appears. It remains on the LCD for 2 minutes, then the screen will go dark. The LCD will become active again when any key is pressed.

Figure 57 Screen saver window

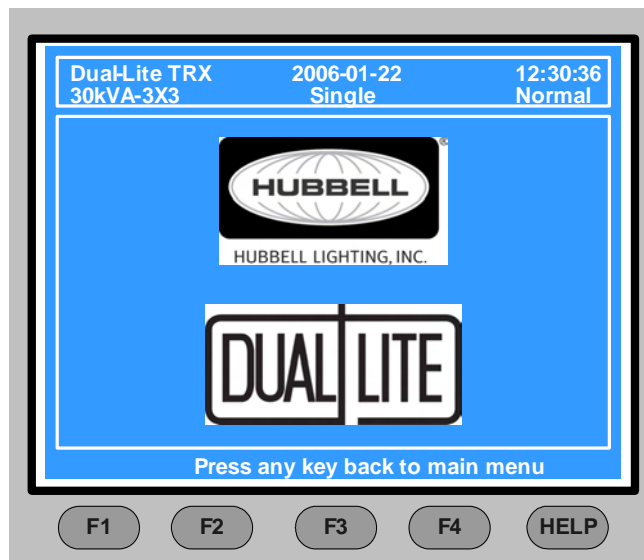

8.13 Pop-Up Windows

Pop-up prompt windows appear when the user must confirm a choice or perform an operation. This section describes the pop-up windows.

8.13.1 From Bypass to Inverter Mode With Power Interruption

If the bypass voltage or frequency exceeds the synchronized range and utility voltage or frequency is normal, the inverter cannot be in synchronization with the bypass, and the output can only transfer to inverter after an interruption of about 15ms when the user presses the INVERTER ON button. Before transferring, the system will let the user confirm whether the interruption can be accepted, as shown at right. If the bypass voltage returns to normal before the user makes confirmation, the UPS will transfer to inverter mode automatically. At the same time, the prompt window will close.

Transfer with Interrupt,
please confirm or cancel

8.13.2 From Inverter to Bypass Mode With Interruption

If the bypass voltage or frequency exceeds the synchronized range and the UPS is in inverter mode, the system must let the user to confirm and accept the power interruption danger before pressing the INVERTER OFF button to shut down the output of the inverter. The user can also cancel the shutdown operation, as shown at right. If the bypass voltage returns to normal before the user makes the confirmation, the UPS will transfer to bypass operation mode automatically, and at the same time the prompt window will disappear soon.

This operation leads to
output shutdown
Confirm or cancel

8.13.3 System Self-Test

When a system self-test is completed, a pop-up window reports the results of the test, as shown at right.

- Press the **F4** (Enter) key and the pop-up window closes.

System Self-Test finished,
Everything is OK

8.13.4 Battery Capacity Test Confirmation

When a battery capacity test is started from the Command menu, the battery will be discharged to low-battery warning level. The TRX asks for confirmation before the test is started, as shown at right.

- To confirm the choice and begin the battery capacity test, press the **F4** (Enter) key and the pop-up window disappears.
- To cancel the test, press the **F1** (ESC) key. The pop-up window disappears.

Battery will be depleted,
Confirm or cancel



NOTE

For a battery capacity test to function properly, the load must be between 20% and 100%.

8.13.5 Battery Self-Test Aborted, Condition Not Met

When a battery capacity test is started from the Command menu and the battery self-test condition is inadequate, the TRX will not perform a battery test. User should check whether the battery state is boost charging and whether the load level is greater than 20 percent.

- Press the **F4** (Enter) key and the pop-up window closes.

Battery Self-Test aborted,
Conditions not met

8.13.6 Battery Refresh Charge Aborted, Condition Not Met

When a battery refreshing charge is started from the Command menu and battery refreshing condition fails to meet requirements, the TRX will not perform a battery refreshing charge. User should check if boost charging condition is not enough, such as (No battery, charger failed, etc.).

- Press the **F4** (Enter) key and the pop-up window closes.

Battery Refresh Charge
aborted,
Conditions not met

9.0 OPERATING INSTRUCTIONS

9.1 TRX Operating Modes

The TRX can operate in any of four modes, as shown in **Table 23**. This section provides instructions on switching between modes, resetting the UPS, switching the inverter On and Off and performing other operations.

Table 23 UPS operating modes

Operating Mode	Rotary Switch Position	Description
Normal Operation	NORMAL	The UPS is powering the load.
On Maintenance Bypass	MAINT	The UPS is shut down but the load is connected to utility power via the Maintenance Bypass Supply line. NOTE: The load is not protected against disturbances in AC input power in this mode.
On Test	TEST	No load power is supplied by the UPS. The load is connected to utility power via the Maintenance Bypass Supply line. NOTE: The load is not protected against disturbances in AC input power in this mode.
On Static Bypass	BYPASS or NORMAL	The load power is supplied through the static bypass line. This may be considered as a temporary mode during load transfers between inverter and maintenance bypass or supply under abnormal operating conditions.



NOTE

1. The user controls and indicators mentioned in these procedures are identified in **8.0 - Operator Control and Display Panel**.
2. The audible alarm may sound at various points during these procedures. It can be canceled at any time by pressing the **SILENCE ON/OFF** push button.



NOTE

This unit refers to some modes and conditions that are set or adjusted using proprietary service software. To take advantage of all the available features for the TRX, the unit must be commissioned by a factory-trained service engineer.

9.1.1 Power Switches

The UPS can be isolated by means of power switches, mounted inside the cabinet and accessible after opening the front door.

The location of the UPS power switches is shown in **Figure 58**.

Figure 58 Power switches - 10kVA TRX



The UPS unit power switches are CB1 and SW1.

- **CB1 - Input Isolator.** Connects the utility supply to the UPS input.
- **SW1 - Rotary switch.** Has four positions—NORMAL, BYPASS, TEST and MAINT—that correspond to different positions of the SW1-A/B/C/D.

The positions of the rotary switch (SW1) are:

- **SW1-A - Output Isolator.** Connects the output of the UPS to the load.
- **SW1-B - Neutral Isolator.** Connects neutral to the UPS.
- **SW1-C - Bypass Isolator.** Connects the UPS with the bypass supply.
- **SW1-D - Maintenance Bypass Isolator.** Permits supply of the load directly by the bypass line for maintenance of the UPS unit.

The functions of the rotary switch are shown in **Table 24**.

Table 24 Rotary switch configuration

Rotary switch position	OUTPUT (SW1-A)	BYPASS (SW1-C)	MAINT (SW1-D)	NEUTRAL (SW1-B)
NORMAL	✓	✓		✓
BYPASS	✓	✓		✓
TEST		✓	✓	✓
MAINT			✓	



NOTE

Do NOT turn the rotary switch too fast. Allow the rotary switch to stay in each position at least three seconds before turning it to the next position.

9.2 UPS Start Up

The TRX must be fully installed and commissioned before start up, and external power isolators must be closed. Once those general conditions are met, the UPS may be started.

9.2.1 Start-Up Procedure

To start the UPS from a fully powered-down condition:

1. Open the UPS door to gain access to the main power switches.

WARNING

During this procedure the output terminals will become live.

If any load equipment is connected to the UPS output terminals, please check with the load user and ascertain whether it is safe to apply power to the load. If the load is not ready to receive power, then ensure that it is safely isolated from the UPS output terminals.

CAUTION

Do not operate the rotary switch too fast. Always wait at least three seconds when rotating the switch from one position to another.

2. Turn the rotary switch to TEST.
3. Close CB1.

The bypass contactor (M2) closes automatically and the LCD begins to show start-up screens.

The Rectifier indicator flashes green while the rectifier is starting up. It stops flashing and becomes solid green about 30 seconds after the rectifier enters the normal operation state.

After initialization, the bypass static switch closes. Because output switch SW1-A is still open, the UPS channels power through Maintenance Bypass Supply line (SW1-D). The bypass indicator extinguishes, provided that the bypass is normal.

The opening display is shown in the figure at right.

The UPS Mimic display indicators will be:

Indicator	State
Rectifier indicator	Off
Battery indicator	Off
Bypass indicator	Off
Inverter indicator	Off
Load indicator	Off
Status indicator	Off

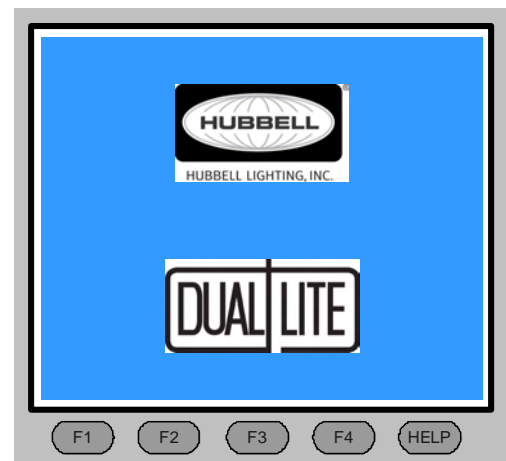

WARNING

Do NOT turn the rotary switch until the rectifier indicator stops flashing green.

4. Turn the rotary switch to BYPASS.
The maintenance switch SW1-D opens and output switch SW1-A closes. The UPS powers from static bypass instead of from maintenance bypass. The bypass and load indicators turn on. The design of the rotary switch ensures uninterrupted output.

Indicator	State
Rectifier indicator	Green
Battery indicator	Off
Bypass indicator	Green
Inverter indicator	Off
Load indicator	Green
Status indicator	Amber

5. Turn the rotary switch to NORMAL, then press the INVERTER ON control button for 2 seconds. The inverter will start and the inverter indicator will flash green. After the inverter is ready, the UPS transfers from bypass to inverter, the bypass indicator turns off and the inverter and load indicators turn on.

The UPS is operating normally. The UPS Mimic display indicators will:

Indicator	State
Rectifier indicator	Green
Battery indicator	Off
Bypass indicator	Off
Inverter indicator	Green
Output indicator	Green
Status indicator	Green

9.2.2 Verify Switching Between Operation Modes

Switch from Normal Mode to Battery Mode

- Open CB1 to enter battery mode. This breaks the utility connection to the TRX. To return to normal mode, close CB1 after a few seconds. The rectifier will restart automatically after 10 seconds and resume feeding power to the inverter.

Switch from Normal Mode to Bypass Mode

- Press INVERTER OFF button to switch to bypass mode.



NOTE

In bypass mode, the load is being powered by the utility and is not receiving conditioned power through the inverter.

Switch from Bypass Mode to Normal Mode

- Turn the rotary switch to NORMAL.
- In bypass mode, press the INVERTER ON button. When the inverter is ready, the UPS will switch to normal mode.

9.3 Switching the UPS from Normal to Maintenance Bypass

Follow the procedure below to transfer the load from the inverter output to the Maintenance Bypass line of the UPS.



CAUTION

Before performing this operation, read the messages on the LCD to be sure that bypass supply is regular and the inverter is synchronous with it. If those conditions are not present, there is a risk of a short interruption in powering the load.

This procedure assumes that UPS is operating normally.

1. Press the INVERTER OFF button on the right side of the operator control panel for longer than 2 seconds.

The Inverter indicator will turn off and the status indicator (6) will turn amber and an audible alarm will sound. The load will transfer to static bypass and the inverter will shut off.



NOTE

Pressing the Alarm Silence Switch cancels the audible alarm, but leaves the warning message displayed until the appropriate condition is rectified.

2. Open the UPS door to gain access to the main power switches, SW1 and CB1.
3. Turn the rotary switch to BYPASS position. The UPS Bypass Static Switch still supply power to load.
4. Turn the rotary switch to TEST. The load is now on maintenance bypass.
5. Turn the rotary switch to MAINT.
6. Open rectifier switch CB1. All operator indicators and messages will turn off as the utility driven internal power supplies decay. The unit will power down, but the load will continue to be supplied by the manual Maintenance bypass.



WARNING

Wait 5 minutes for the internal DC busbar capacitors to discharge before attempting to remove the internal protective barriers.



WARNING

Even with the UPS in maintenance bypass and “Off,” portions of the unit are still energized. Service is to be performed by qualified personnel only.



CAUTION

The load equipment is not protected from normal supply aberrations when operating in the maintenance bypass mode.

9.4 Powering Down the UPS

To power down the UPS completely, follow the procedures in **9.3 - Switching the UPS from Normal to Maintenance Bypass**.

To completely isolate the UPS from the AC supplies, the main external power input isolator (both isolators, where separate supplies are provided for rectifier and bypass) should be opened (see **Figure 59**).



WARNING

To prevent injury to personnel, lockout or tagout the service supplies.

9.5 Powering Down the UPS and Maintaining Power to Load



NOTE

An external Maintenance Bypass Cabinet must be installed before attempting to perform the following procedure.

If the UPS needs to be shut down completely while maintaining power to the load, follow these steps:

1. Perform **Steps 1 through 5 in 9.3 - Switching the UPS from Normal to Maintenance Bypass.**

2. Close the external maintenance bypass rotary switch to Maint position.

On the primary input distribution panel, which is often located distant from the UPS area, a label should be posted advising service personnel that the UPS circuit is under maintenance.



WARNING

Wait 5 minutes for the internal DC busbar capacitors to discharge.

The UPS is now completely powered down.



NOTE

The Maintenance Bypass Power switch may be operated at any time while the UPS is powered down to connect the load to the maintenance bypass supply if required.

The procedure can be performed only after the installation has been completed (which includes the maintenance bypass cabinet), after the system has been placed in operation by authorized personnel. See the reference drawing of **Figure 59** for more information.

Figure 59 Typical configuration for single UPS with external maintenance bypass cabinet

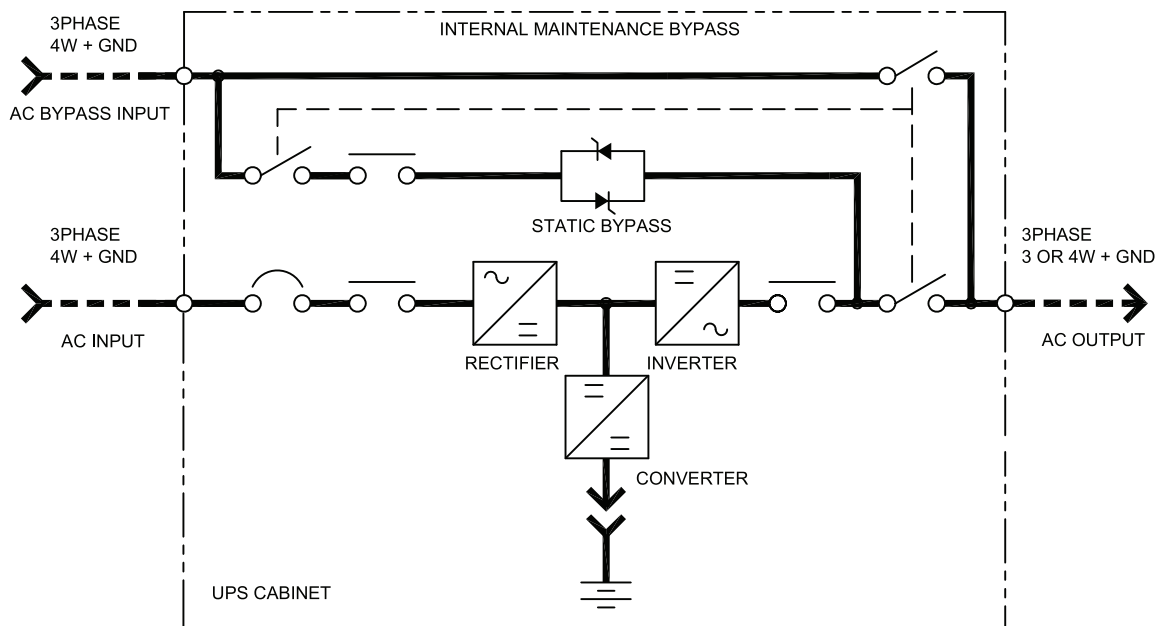

9.6 Emergency Shutdown With EPO

This circuit has been designed to switch off the UPS in emergency conditions (i.e., fire, flood, etc.). The system will turn off the rectifier, inverter and stop powering the load immediately (including the inverter and bypass), and the battery stops charging or discharging.

If the input utility is present, the UPS's controls will remain active; however, the output will be turned off. To remove all power from the UPS, the external feeder breaker should be opened.

9.7 Auto Restart

When the main and bypass sources fail, the UPS draws power from the battery system to supply the load until the batteries are depleted. When the UPS reaches its end of discharge (EOD) threshold, it will shut down.

The UPS will automatically restart and enable output power:

- after utility power is restored
- if “Auto Recovery after EOD Enabling” is enabled
- after the “Auto Recovery after EOD Delay Time” expires (the default delay is 10 minutes)

During the auto recovery delay, the TRX will be charging its batteries to provide a safety margin for equipment shutdown if input power fails again.

If the “Auto Recovery after EOD Enabling” feature is disabled, the user must restart the system manually.

9.8 Reset After Shutdown for Emergency Stop (EPO Action) or Other Conditions

Once all appropriate measures have been taken to correct the problem indicated by the alarm message appearing on the operator control panel display, carry out this procedure to restore the UPS to regular operation following an EPO action or for the following reasons: Inverter Overtemperature, Cut-off Overload, Battery Overvoltage, excessive switching (BYP: XFER COUNT BLOCK), etc.

When the user confirms that the fault is cleared:

1. Press the FAULT CLEAR button to let the system exit the emergency off state.



NOTE:

A UPS manufactured before March 2006 may first require a full power down, i.e., manual opening of the input breakers, for the “Fault Clear” to take effect.



NOTE

The rectifier will start again, the battery contactor will close and the bypass will begin to power the load. The Rectifier indicator (1) flashes while the rectifier is starting up. When the rectifier enters the normal operation state (about 30 seconds), the rectifier indicator turns green.

2. Press the INVERTER ON button (10) on the right side of the operator control panel for longer than 2 seconds.



NOTE

The rectifier will be turned on automatically when the overtemperature fault disappears at 5 minutes after the disappearance of overtemperature signals.

After the EPO button is pressed, if the input utility is removed, the UPS will shut down completely. When input utility is returned, if the rotary switch (SW1) is in either Bypass or in Normal position, the UPS will start up on Bypass. There will be power at the output terminals of the UPS.



WARNING

If the rotary switch is in the Maint. position and input utility is present, there will be power at the output terminals of the UPS.

9.9 Battery Protection

9.9.1 Battery Undervoltage Pre-Warning

Before the end of discharge, the TRX displays a battery undervoltage pre-warning. After this pre-warning, the battery has the capacity for 5 minutes discharging with full load (default time). The TRX can be user-configured to display this warning from 3 to 60 minutes before end-of-discharge.

9.9.2 Battery End-of-Discharge (EOD) Protection

If the battery voltage is lower than the end-of-discharge voltage, the battery converter will be shut down.

9.9.3 Battery Fuse-Blow Warning

Battery current protection is provided by the battery fuses FU7 and FU8. If a battery fuse blows, the TRX displays the battery fuse-blow warning and the battery converter will be shut down.



NOTE

All equipment servicing procedures must be carried out only by trained personnel.

9.10 Isolating and Integrating One Module in a Multi-Module System

1. Turn Off inverter
2. Open External Output CB1
The UPS enters Isolation Status automatically, parallel signaling and communication becomes masked, and output becomes inhibited.
3. Power Off unit for maintenance.
4. Power On unit with External Output CB1 open.
5. Unit enters Test Mode by configuration software setting.
6. Diagnosis or testing.
7. The UPS exits Test Mode by configuration software setting.
Output becomes inhibited because of Isolation Status.
8. Return all switches to the Normal position, including External Output Circuit Breaker 1.
9. Close External Output Circuit Breaker 1.
The UPS exits Isolation Status automatically, parallel signaling and communication recovers, output becomes enabled but interlocking works now.
10. Turn On inverter and join the parallel system.



WARNING

Hazardous Battery Voltage

No operator serviceable parts are located behind covers that require a tool for their removal.

Only qualified service personnel are authorised to remove such covers.

The UPS battery and connecting terminals remains energized at hazardous voltage levels at all times. The battery is located behind protective covers that require a tool for their removal: inside the UPS cabinet, inside a free-standing battery cabinet or on open racks inside a dedicated battery room that may be locked.

9.11 Inserting One Module into a Multi-Module System

This procedure outlines how to integrate a UPS module that has been previously isolated from other modules of a group of paralleled UPS modules. It is assumed that the installation is complete, the system has been commissioned by authorized personnel and the external power isolators are closed.

WARNING

Mains voltage will be applied to UPS output terminals.

No operator serviceable parts are located behind covers that require a tool for their removal.

Only qualified service personnel are authorised to remove such covers.

1. Open the UPS door to gain access to the main power switches.
2. Rotate the switch to Test position. The LCD becomes active.
3. Close Input breaker CB1
The Rectifier indicator flashes on the UPS mimic panel during the startup of the rectifier and becomes steady green once the rectifier reaches normal operation state after about 30s.
4. Close external battery circuit breaker QF1 (where an external battery is used). This breaker is inside the battery cabinet (if used) or is otherwise adjacent to the battery racks.
5. After the UPS detects the batteries, the red battery indicator extinguishes when the battery charger starts operation.
6. Rotate switch to Bypass position
7. Turn the rotary switch to NORMAL, then press the INVERTER ON control button for 2 seconds.
The inverter will start up and the inverter indicator flashes while it synchronizes to the load voltage and frequency. After the inverter is ready, the UPS connects to the load, the inverter indicator becomes steady green and the output indicator turns green.
8. Check that no “Warning” message is displayed in the top right corner of the LCD Monitor and that the indicators have the status shown below.

# LED	LED Function	Status
1	Rectifier indicator	Green
2	Battery indicator	Off
3	Bypass indicator	Off
4	Inverter indicator	Green
5	Output indicator	Green
6	Alarm indicator	Off

The UPS is now operating in NORMAL mode.

9.12 Shutting Down a Multi-Module System Without System Bypass Switch



NOTE

Before beginning this procedure, shut down the connected load to prevent the possibility of damage. This procedure will shut off power to the load.

1. Open the UPS door to gain access to the main power switches, SW1 and CB1 of a UPS in the system.
2. Turn the rotary switch to BYPASS position. Rotating any UPS Rotary Switch (SW1) to the Bypass position will force all UPS modules to Static Bypass
3. Repeat **Steps 1** and **2** for the rest of the units in the system.



NOTE

If this operation will be performed on multiple units, the procedures should be performed on each unit with as little delay as possible.

4. Turn the rotary switch of each unit in the system to TEST. The load is now on maintenance bypass.
5. Turn the rotary switch of each unit in the system to MAINT.



NOTE

The following step will shut off power to the connected load.

6. Open system output breaker. The load will now be disconnected.
7. Open rectifier switch CB1. All operator indicators and messages will turn off as the utility-driven internal power supplies decay.
8. To isolate a module:
 - a. For systems that have UPS input breakers in paralleling cabinet, open the UPS input breaker for the unit you want to isolate.
 - b. For systems that do not have UPS input breakers in paralleling cabinet, the utility source to the UPS will need to be opened.

9.13 Shutting Down a Multi-Module System With System Bypass Switch

1. In the Bypass Cabinet, rotate the system bypass switch to the Bypass position. This will force the UPS's in the system to Static Bypass.
2. Open the UPS door to gain access to the main power switches, SW1 and CB1 of a UPS in the system.
3. Turn the UPS SW1 to BYPASS position for each module in the system
4. Repeat **Steps 2** and **3** for the rest of the units in the system.
5. Turn the rotary switch of each unit in the system to TEST.
6. Turn the rotary switch of each unit in the system to MAINT.
7. Open rectifier switch CB1. All operator indicators and messages will turn off as the utility driven internal power supplies decay.
8. To isolate the UPS(s) from the bypass cabinet, open the module input and output isolation breaker(s).

9.14 Commissioning a Parallel System



CAUTION

The operations described in this section must be performed by authorized electricians or qualified technical personnel. If you have any difficulty, do not hesitate to contact Technical Services at 1-800-543-2378.

Check the input and output wiring of each UPS module. Ensure that the phase rotation sequence of the main inputs and the bypass inputs and outputs of each UPS module are the same. Ensure the parallel cables are connected firmly.

It is assumed that the installation is complete, the system has been commissioned by authorized personnel and the external power isolators are closed. **Before start up, disconnect the load.**

9.15 Maintenance Bypass Cabinet Operating Procedures

9.15.1 Start Up and Initialization

Follow these steps to start the UPS while connected to the Maintenance Bypass.

1. Set Maintenance Bypass switch to the Normal position on Maintenance Bypass Cabinet.
2. Close the system input circuit breaker.
3. Start the UPS as instructed in **9.2 - UPS Start Up**.
4. Close system output circuit breaker.

9.15.2 Shutting Down the UPS

Use the following procedure to power down the system.

1. Turn the TRX off by following the procedures in **9.4 - Powering Down the UPS**.
2. Open system output circuit breaker.
3. Open system input circuit breaker.

9.15.3 Transferring System from UPS to Maintenance Bypass Operation

1. Turn the bypass switch (SW) to the bypass position on the Maintenance Bypass Cabinet. The UPS will switch to bypass mode.
The connected equipment is now powered from the bypass source and is NOT protected.
2. To isolate the UPS from the system, rotate the bypass switch to the maintenance position.

9.15.4 Transfer the System from Maintenance Bypass to UPS Operation

1. Turn the bypass switch (SW) to the Normal position on the Maintenance Bypass Cabinet. The UPS will go to bypass mode.
2. Press the "Inverter On" button on the UPS and allow the UPS to go to normal mode.
3. The connected equipment is now powered and protected by the UPS.

9.15.5 Transfer the System from UPS Operation to Maintenance Bypass

If the UPS needs to be shut down completely while maintaining power to the load, follow these steps:

1. Perform **Steps 1 through 5 in 9.3 - Switching the UPS from Normal to Maintenance Bypass**.
2. Rotate Maintenance Bypass Switch to Maintenance position.
3. Post a label on the primary input distribution panel, which often is installed outside the UPS area, advising personnel that the UPS circuit is under maintenance.

The UPS is now completely powered down.



WARNING

Wait 5 minutes for the internal DC busbar capacitors to discharge.



NOTE

The Maintenance Bypass power switch may be operated at any time while the UPS is powered down to connect the load to the maintenance bypass supply.

The procedure can be performed only after the installation has been completed (which includes the maintenance bypass cabinet), after the system has been placed in operation by authorized personnel and after the external power switches have been closed. See **Figure 60** for more information.

Figure 60 Single UPS with external Maintenance Bypass Cabinet—typical configuration

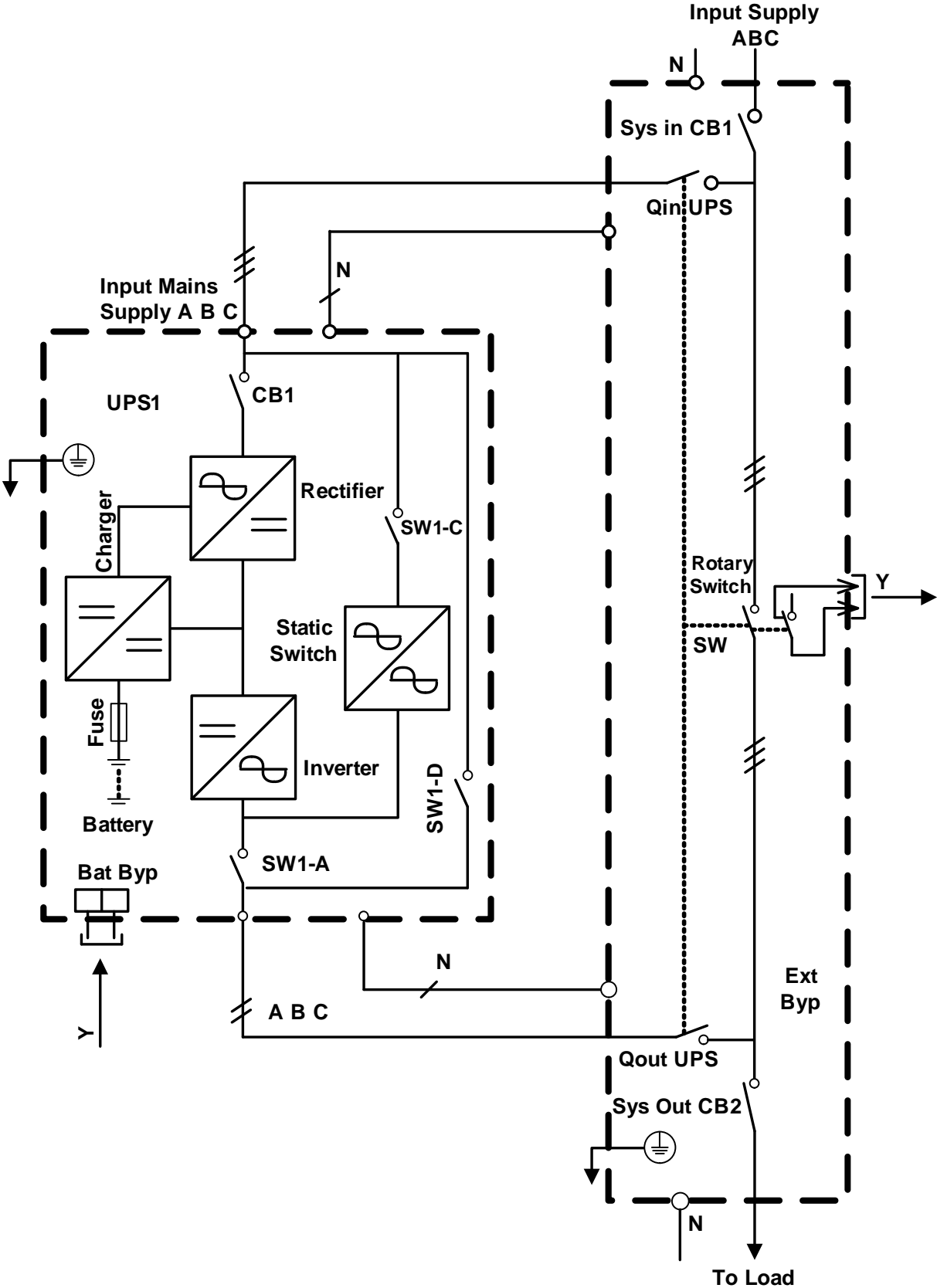

9.16 Parallel System Start Up

1. Start each UPS normally as described in **9.2 - UPS Start Up**
2. Turn on the inverter of each UPS module one at a time.
3. Apply the load after the last UPS module transfers to inverter. The total load can be determined through the LCD of either UPS.
4. Verify the load rate of each UPS module. If the load rates are roughly the same, then the parallel system may be assumed to be operating normally.



NOTE

If one module cannot transfer to inverter mode long after its inverter is on, its output connection may not be good or its output phase rotation may not be coincident with other modules. At this time, the LCD for the UPS module will display “inverter asynchronous” and the inverter indicator will flash continuously. If either UPS module makes abnormal noise after it transfers to inverter, its parallel cables may be incorrectly connected.

9.17 Replacing Dust Filters

1. Open the UPS door.
2. The dust filters are behind the door. For each filter, there is a bracket on either side holding the dust filter in place, as shown in **Figure 61**.
3. Remove one bracket and loosen the other. The second bracket need not be removed.
4. Remove the old filter and replace with the new filter
5. Reinstall the bracket that was removed and tighten the other bracket.

Figure 61 Dust filter replacement

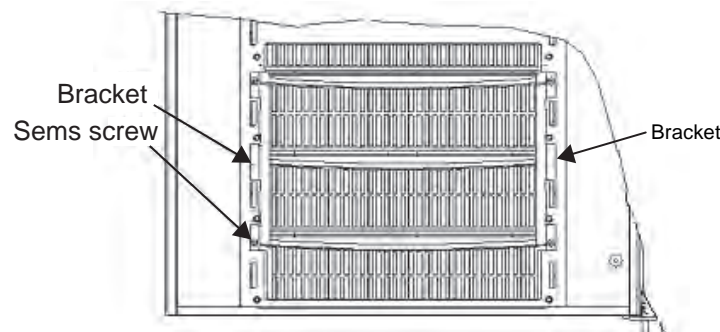

10.0 UPS SPECIFICATIONS

These specifications describe requirements for the Dual-Lite TRX UPS.

10.1 Conformity and Standards

The UPS has been designed to conform to the following standards:

- IEEEC1000-4-5
- ASME
- CSA 22.2, No. 107.1
- FCC Part 15, Class A
- ISO 9001
- National Electrical Code (NFPA-70)
- NEMA PE-1
- OSHA
- UL Standard 1778

The UPS system has UL and c-UL approval.

10.2 UPS Environmental

The UPS is designed to operate under the following environmental conditions without damage or degradation in electrical operating characteristics:

Table 25 Environmental characteristics

Rated Power	10-30kVA
Operating Temperature, UPS	32°F to 104°F (0°C to 40°C)
Optimal Operating Temperature, Battery	68°F to 86°F (20°C to 30°C)
Relative Humidity	0 to 95%, non-condensing
Acoustical Noise, dBA at 39 in. (1m)	54
Altitude of Operation	≤1000m per IEC 62040/3
Storage-Transport Temperature, UPS	-4°F to 158°F (-20°C to 70°C)
Storage-Transport Temperature, Battery	-4°F to 86°F (-20°C to 30°C)

10.3 UPS Mechanical Characteristics

Table 26 Mechanical characteristics

Parameter	10kVA	15kVA	20kVA	30kVA
Width, in. (mm)	24 (600)			
Depth, in. (mm)	32.5 (825)			
Height, in. (mm)	63 (1600)			
Weight Without Inner Batteries, lb. (kg)	450 (205)	450 (205)	550 (250)	550 (250)
UPS12-100 weight	954 (433)	954 (433)	1054 (478)	1054 (478)
UPS12-140 weight	1098 (498)	1098 (498)	1198 (543)	1198 (543)
Heat Dissipation, BTU/H (kWH)	2800 (0.82)	4200 (1.23)	5500 (1.61)	8300 (2.43)
Airflow, CFM (m ³ /h)	384 (652)	558 (948)	522 (886)	834 (1417)
Cable Entry	Bottom or top			
Color	PMS 877			
Protection Grade (with open/closed front doors)	IP 20			

10.4 UPS Electrical Characteristics

Table 27 UPS terminal

Input (for single-input unit)

Unit Rating	Nominal Input Current	Maximum Input Current	OCP Current	OCP Device Rating	Bolt Size	Maximum Recommended Lug	
						Lug T&B One Hole 54000	Lug T&B One Hole REDDY
10	28	35	42	45	6M (1/4")	54105	62204
15	42	53	63	70	6M (1/4")	54106	62204
20	56	70	84	90	6M (1/4")	54107	62204
30	83	104	125	125	6M (1/4")	54152	62205

Rectifier input (for dual input unit only)

Unit Rating	Nominal Input Current	Maximum Input Current	OCP Current	OCP Device Rating	Bolt Size	Maximum Recommended Lug	
						Lug T&B One Hole 54000	Lug T&B One Hole REDDY
10	25	31	37	40	6M (1/4")	54130	62204
15	37	47	57	60	6M (1/4")	54106	62204
20	50	63	76	80	6M (1/4")	54107	62204
30	75	94	113	125	6M (1/4")	54152	62205

Bypass input (for dual input units)

Unit Rating	Nominal Input Current	OCP Current	OCP Device Rating	Bolt Size	Maximum Recommended Lug	
					Lug T&B One Hole 54000	Lug T&B One Hole REDDY
10	28	35	35	6M (1/4")	54105	62204
15	42	53	60	6M (1/4")	54106	62204
20	56	70	70	6M (1/4")	54107	62204
30	83	104	110	6M (1/4")	54152	62205

Output

Unit Rating	Nominal Output Current	OCP Current	OCP Device Rating	Bolt Size	Maximum Recommended Lug	
					Lug T&B One Hole 54000	Lug T&B One Hole REDDY
10	28	35	35	6M (1/4")	54130	62204
15	42	53	60	6M (1/4")	54106	62204
20	56	70	70	6M (1/4")	54106	62204
30	84	105	110	6M (1/4")	54108	62205

Battery

Unit Rating	Battery Current	OCP Current	OCP Device Rating	Bolt Size	Maximum Recommended Lug	
					Lug T&B One Hole 54000	Lug T&B One Hole REDDY
10/15	55	55	70	6M (1/4")	54106	62204
20/30	110	110	125	8M (5/16")	54153	62212

- Nominal (Nom) current is based on full rated output load.
- Maximum (Max) current (125% of nominal) is short duration for battery recharge conditions.
- UPS input and bypass cables must be run in separate conduit from output cables.
- Nominal battery voltage is shown at 2.0 volts/cell per NEC 480-2.
- OCPD = Overcurrent Protection Device. Recommended AC input and AC output overcurrent protection represents 125% of nominal full load current (continuous) per NEC 215.
- Minimum-sized grounding conductors to be per NEC 250-122. Parity-sized ground conductors are recommended. Neutral conductors to be sized for full capacity per NEC 310-15 (b)(4). References are per NEC 2005.
- Wiring requirements:
 - AC Input: 3-phase, 4-wire, plus ground output.
 - AC Output: 3-phase, 3- or 4-wire, plus ground
- All wiring is to be in accordance with national and local electric codes.

10.4.1 Battery Manufacturers and Models

Either of two manufacturers' batteries will be installed in the TRX 10-30 kVA 208V as shipped. Below are the battery makers and the models they supply.

Table 28 Approved batteries

Battery Manufacturer	Models Supplied		
Energys Yuasa	NPX-80FR	NPX-100FR	NPX-150FR
C&D Dynasty	UPS12-100MR	UPS12-140MR	-

10.4.2 Input Rectifier

Table 29 Rectifier input power

Rated Power	10kVA	15kVA	20kVA	30kVA
Rated Voltage, VAC	120/208			
Supply	3-phase, 4-wire plus ground			
Input Voltage Tolerance, VAC (without derating)	166-239			
Frequency, Hz	50 / 60			
Input Frequency Tolerance %	±10			
Power Factor	≤ 0.99 at full load ≤ 0.95 at 50% load			
Harmonic Current	Less than 4% at full rated UPS output load			
Input Current, ¹ Nominal, A	28	42	56	83
Output Current, Nominal, A	28	42	56	83

Notes:

- Overload capacity of input current:
 - 100% I_{max} <I<125% I_{max}: 10 min.
 - 125% I_{max} <I<150% I_{max}: 1 min.
 - I>150%: Limits input current immediately

10.4.3 DC Intermediate Circuit

Table 30 DC intermediate circuit

Rated Power	10kVA	15kVA	20kVA	30kVA
Recommended number of lead-acid batteries	Number of batteries is 24 jars (12V per jar), or 144 cells (2V per cell) for VRLA. The unit is shipped with a nominal voltage of 288VDC.			
Recommended float charge voltage	2.27VDC*			
Recommended boost charge voltage	2.3VDC*			
Recommended end of discharge voltage	1.65-1.8 VDC			
Maximum recharge battery current, A	7.5	7.5	15	15
Maximum boost charge duration, min.*	1440			
Boost-float threshold current, A*	0.1 C default			
Temperature voltage compensation, mV/°C*	3			
Ripple voltage superimposed %	≤ 1			

* Set by configuration software and based on usage of VLRA batteries.

10.4.4 Inverter Output

Table 31 Inverter output

Rated Power	10kVA	15kVA	20kVA	30kVA
Rated voltage, VAC	120/208			
Supply	3-phase, 4-wire plus ground			
Frequency, Hz	50 / 60			
Rated Power, kW	8	12	16	24
Three -phase transient overload, min. load	10 minutes - 105-125% load			
	1 minute - 126-150% load			
Voltage Regulation %	±1.0% three-phase RMS average for a balanced three-phase load ±2.0% three-phase RMS average for a 100% unbalanced load			
Frequency Regulation %	Nominal frequency regulation is ±0.05% in single-module mode, and±/- 0.25% in parallel mode.			
Maximum rate of change of frequency, Hz/sec	For single mode, the slew rate is adjustable from 0.1Hz/s to 3Hz/s			
Current rating of neutral cable, A	1.5 x input current			

10.4.5 Bypass Input

Table 32 Bypass input

Rated Power	10kVA	15kVA	20kVA	30kVA
Rated voltage, VAC	120/208			
Supply	Three-phase, 4-wire plus ground			
Rated Current, A				
208VAC	28	42	56	83
Bypass voltage tolerance %	Upper limit: +10%, +15% or +20% Lower limit: -10%, -20%, -30% or -40%		Upper limit default: +15% Lower limit default: -20%	
Frequency, Hz	50 / 60			
Input frequency tolerance %	± 10 or ± 20%; default ±10%			
Current rating of neutral cable, A	1.5 x input current			
Bypass overload capacity (all ratings)			Time Load Long-term operation: <135% load 10 minutes: 135% - 170% load 100milliseconds: 1000% full UPS rated output current	

11.0 SPECIFICATIONS AND TECHNICAL DATA

11.1 Lug Size and Torque Requirements

Use commercially available solderless lugs for the wire size required for your application. Refer to **Table 33**. Connect wire to the lug using tools and procedures specified by the lug manufacturer.

Table 33 Torque specifications

Nut and Bolt Combinations				
Bolt Shaft Size	Grade 2 Standard		Electrical Connections with Belleville Washers	
	Lb-in	N-m	Lb-in	N-m
1/4	53	6.0	46	5.2
5/16	107	12	60	6.8
3/8	192	22	95	11
1/2	428	22	256	29

Circuit Breakers With Compression Lugs (For Power Wiring)		
Wire Size or Range	Lb-in	N-m
#6 - #4	100	11
#3 - #1	125	14
1/0 - 2/0	150	17
3/0 - 200 MCM	200	23
250 - 400 MCM	250	28
500 - 700 MCM	300	34

Circuit Breakers With Compression Lugs (For Power Wiring)		
Current Rating	Lb-in	N-m
400 - 1200 Amps	300.00	34.00

Terminal Block Compression Lugs (For Control Wiring)		
AWG Wire Size or Range	Lb-in	N-m
#22 -#14	3.5 to 5.3	0.4 to 0.6

NOTE: Use the values in this table unless the equipment is labeled with a different torque value.

Table 34 Battery torque rating

Battery	Initial Torque in-lb (N-m)	Annual Torque in-lb (N-m)
UPS12-100MR	40 (4.5)	32 (3.48)
UPS12-140MR	40 (4.5)	32 (3.48)
UPS12-200MR	40 (4.5)	32 (3.48)
UPS12-270MR	40 (4.5)	32 (3.48)
UPS12-310MR	65 (7.4)	52 (5.88)
UPS12-370MR	65 (7.4)	52 (5.88)
UPS12-475MR	110 (12.4)	110 (12.4)

Table 35 Maintenance bypass cabinet electrical data (single input)

kVA	Type	Maintenance Bypass I/P Voltage (VAC)	Bypass Cabinet Max Input Current	Cabinet Input OCP CB Size (A)	O/P Voltage (VAC)	Nominal O/P Current Rating (A)	Output OCP CB Size (A)
30	A, J	208	104	125	208	83	125
30	B, K	480	47	60	208	83	125
30	B, K	600	37	50	208	83	125
30	B, K	220	101	125	208	83	125
30	C, L	480	48	60	480	36	50
30	C, L	600	38	50	600	29	40
30	C, L	220	105	125	220	79	100
30	D, M	480	47	60	208	83	125
30	D, M	600	38	50	208	83	125
30	D, M	208	108	150	208	83	125
30	D, M	220	103	125	208	83	125
30	D, M	240	93	125	208	83	125
30	E, N	480	48	60	480	36	50
30	E, N	600	39	50	600	29	40
30	E, N	220	106	125	220	79	100
20	A, J	208	69	90	208	56	70
20	B, K	480	31	40	208	56	70
20	B, K	600	25	30	208	56	70
20	B, K	220	68	90	208	56	70
20	C, L	480	32	40	480	24	30
20	C, L	600	26	40	600	19	30
20	C, L	220	70	90	220	52	70
20	D, M	480	31	40	208	56	70
20	D, M	600	25	40	208	56	70
20	D, M	208	72	90	208	56	70
20	D, M	220	68	90	208	56	70
20	D, M	240	62	80	208	56	70
20	E, N	480	32	40	480	24	30
20	E, N	600	26	40	600	19	30
20	E, N	220	70	90	220	52	70
15	A, J	208	52	70	208	42	60
15	B, K	480	23	30	208	42	60
15	B, K	600	19	30	208	42	60
15	B, K	220	51	70	208	42	60
15	C, L	480	24	30	480	18	30
15	C, L	600	19	30	600	14	20
15	C, L	220	52	70	220	39	50
15	D, M	480	23	30	208	42	60
15	D, M	600	19	30	208	42	60
15	D, M	208	54	70	208	42	60
15	D, M	220	51	70	208	42	60
15	D, M	240	47	60	208	42	60
15	E, N	480	24	30	480	18	30
15	E, N	600	19	30	600	14	20
15	E, N	220	53	70	220	39	50

Table 35 Maintenance bypass cabinet electrical data (single input) (continued)

kVA	Type	Maintenance Bypass I/P Voltage (VAC)	Bypass Cabinet Max Input Current	Cabinet Input OCP CB Size (A)	O/P Voltage (VAC)	Nominal O/P Current Rating (A)	Output OCP CB Size (A)
10	A, J	208	35	50	208	28	40
10	B, K	480	16	20	208	28	40
10	B, K	600	12	15	208	28	40
10	B, K	220	34	50	208	28	40
10	C, L	480	16	20	480	12	15
10	C, L	600	13	20	600	10	15
10	C, L	220	35	50	220	26	40
10	D, M	480	16	20	208	28	40
10	D, M	600	13	15	208	28	40
10	D, M	208	36	50	208	28	40
10	D, M	220	34	50	208	28	40
10	D, M	240	32	40	208	28	40
10	E, N	480	16	20	480	12	15
10	E, N	600	13	20	600	10	15
10	E, N	220	35	50	220	26	40

Table 36 Maintenance bypass cabinet electrical data (dual input)

kVA	Type	System I/P Voltage (VAC)	Rectifier Max Input Current	Rectifier Input OCP CB Size (A)	Bypass Max Input Current	Bypass Input OCP CB Size (A)	O/P Voltage (VAC)	Nominal O/P Current Rating (A)	Output OCP CB Size (A)
30	F, P	480	42	50	47	50	208	83	125
30	F, P	600	33	40	37	40	208	83	125
30	F, P	208	95	125	107	125	208	83	125
30	F, P	220	90	125	101	125	208	83	125
30	F, P	240	83	100	93	100	208	83	125
20	F, P	480	28	40	31	40	208	55	70
20	F, P	600	22	30	25	30	208	56	70
20	F, P	208	64	80	71.5	80	208	56	70
20	F, P	220	61	80	68	70	208	56	70
20	F, P	240	56	70	62	70	208	56	70
15	F, P	480	21	30	24	30	208	42	60
15	F, P	600	17	30	19	20	208	42	60
15	F, P	208	49	60	54	60	208	42	60
15	F, P	220	46	60	51	60	208	42	60
15	F, P	240	42	60	47	50	208	42	60
10	F, P	480	14	20	16	20	208	28	40
10	F, P	600	12	15	13	15	208	28	40
10	F, P	208	33	40	36	40	208	28	40
10	F, P	220	31	40	34	40	208	28	40
10	F, P	240	29	40	32	40	208	28	40

Table 37 Multi-module bypass cabinet electrical data

System Size	Type	kVA	System I/P Voltage (VAC)	System Max Input Current	System Input OCP CB Size (A)	O/P Voltage (VAC)	Nominal O/P Current Rating (A)	Output OCP CB Size (A)
1+1	A00, BR0	30	208	104	125	208	83	125
		20	208	70	90	208	56	70
		15	208	53	70	208	42	60
		10	208	35	45	208	28	40
	CR1	30	208	107	150A	208	83	125
	CR1, DR1	30	220	101	150A	208	83	125
	CR1, DR1	30	480	46	70A	208	83	125
	CR1, DR1	30	600	37	60A	208	83	125
	CR1	20	208	71	100A	208	56	70
	CR1, DR1	20	220	68	100A	208	56	70
	CR1, DR1	20	480	31	50A	208	56	70
	CR1, DR1	20	600	25	40A	208	56	70
	CR1	15	208	54	80A	208	42	60
	CR1, DR1	15	220	51	80A	208	42	60
	CR1, DR1	15	480	23	40A	208	42	60
	CR1, DR1	15	600	19	30A	208	42	60
	CR1	10	208	36	60A	208	28	40
	CR1, DR1	10	220	34	50A	208	28	40
CR1, DR1	10	480	16	30A	208	28	40	
CR1, DR1	10	600	12	20A	208	28	40	
2+1	E00	30	208	104	125	208	167	225
		20	208	70	90	208	111	150
	GR1	20	208	146	200	208	111	150
		20	220	138	200	208	111	150
		20	480	63	100	208	111	150
		20	600	51	70	208	111	150
		30	208	219	300	208	167	225
		30	220	207	300	208	167	225
		30	480	95	125	208	167	225
		30	600	76	100	208	167	225
	TR0	30	208	210	300	208	167	225
		20	208	140	200	208	111	150
3+1	J00	30	208	104	125	208	250	400
		20	208	70	90	208	167	225
	LR1	20	208	219	300	208	167	225
		20	220	207	300	208	167	225
		20	480	95	125	208	167	225
		20	600	76	100	208	167	225
		30	208	329	500	208	250	400
		30	220	311	400	208	250	400
		30	480	142	200	208	250	400
		30	600	114	150	208	250	400
	UR0	30	208	315	400	208	250	400
20		208	210	300	208	167	225	

Table 38 Maintenance bypass cabinet lug sizes

Input

Unit Rating	Nominal System Input Voltage	Bolt Size	Maximum Recommended Lug	
			Lug T&B One Hole 54000	Lug T&B One Hole REDDY
30	600	6M (1/4")	54105	62204
30	480	6M (1/4")	54106	62204
30	240	6M (1/4")	54152	62205
30	220	6M (1/4")	54152	62205
30	208	6M (1/4")	54152	62205
20	600	6M (1/4")	NA	62204
20	480	6M (1/4")	54130	62204
20	240	6M (1/4")	54107	62204
20	220	6M (1/4")	54107	62204
20	208	6M (1/4")	54107	62204
15	600	6M (1/4")	NA	62204
15	480	6M (1/4")	NA	62204
15	240	6M (1/4")	54106	62204
15	220	6M (1/4")	54106	62204
15	208	6M (1/4")	54106	62204
10	600	6M (1/4")	NA	62204
10	480	6M (1/4")	NA	62204
10	240	6M (1/4")	54130	62204
10	220	6M (1/4")	54130	62204
10	208	6M (1/4")	54130	62204

Output

Unit Rating	Nominal System Output Voltage	Bolt Size	Maximum Recommended Lug	
			Lug T&B One Hole 54000	Lug T&B One Hole REDDY
30	600	6M (1/4")	54130	62204
30	480	6M (1/4")	54106	62204
30	240	6M (1/4")	54108	62205
30	220	6M (1/4")	54108	62205
30	208	6M (1/4")	54108	62205
20	600	6M (1/4")	NA	62204
20	480	6M (1/4")	54130	62204
20	240	6M (1/4")	54106	62204
20	220	6M (1/4")	54106	62204
20	208	6M (1/4")	54106	62204
15	600	6M (1/4")	NA	62204
15	480	6M (1/4")	NA	62204
15	240	6M (1/4")	54106	62204
15	220	6M (1/4")	54106	62204
15	208	6M (1/4")	54106	62204
10	600	6M (1/4")	NA	62204
10	480	6M (1/4")	NA	62204
10	240	6M (1/4")	54130	62204
10	220	6M (1/4")	54130	62204
10	208	6M (1/4")	54130	62204

Table 39 Battery cabinet physical characteristics

Battery Cabinet Type	Dimensions WxDxH in. (mm)	Net Weight Without Batteries, lb. (kg)
Short Narrow	27.2x31.4x63 (690x825x1600)	551 (250)
Short Wide	58.5x31.4x63 (1488x825x1600)	889 (400)

Table 40 Maintenance Bypass Cabinet weights

UPS Rating	Maintenance Bypass Cabinet Style, lb. (kg)											
	A	B	C	D	E	F	J	K	L	M	N	P
10kVA	408 (185)	545 (247)	675 (306)	602 (273)	732 (332)	630 (286)	403 (183)	540 (245)	670 (304)	597 (271)	728 (330)	630 (286)
15kVA	408 (185)	567 (257)	728 (330)	659 (299)	822 (373)	680 (308)	403 (183)	562 (255)	723 (328)	655 (297)	818 (371)	680 (308)
20kVA	408 (185)	646 (293)	842 (382)	739 (335)	935 (424)	750 (340)	403 (183)	642 (291)	838 (380)	734 (333)	930 (422)	750 (340)
30kVA	408 (185)	694 (315)	893 (405)	807 (366)	1027 (466)	840 (381)	403 (183)	690 (313)	888 (403)	802 (364)	1023 (464)	840 (381)

Table 41 Maintenance bypass cabinet dimensions

Unit	Width	Depth	Height
inch	27.2	31.4	63
mm	690	825	1600

Table 42 Multi-module paralleling cabinet dimensions

1+1 Cabinet Type	Width	Depth	Height
1+N Narrow	27.2	31.4	63
Types A00, BR0, CR1, DR1	690	825	1600
1+N Cabinet Type	Width	Depth	Height
1+N Narrow	27.2	31.4	63
Types A00, E00, J00	690	825	1600
1+N Wide	58.5	31.4	63
All other types	1488	825	1600

11.2 Cable Lengths: Floor to Connection Point Inside UPS

To help calculate the total cable length required, refer to **Table 43** for the distance from the floor to selected connection points inside the TRX. Determine the cable length required to reach the TRX, then add the appropriate length from the table and adequate slack for repair and maintenance.

Table 43 Distance to connection points on the TRX UPS

Connection Point on UPS	Distance	
	From Floor in. (mm)	From Top of Unit in. (mm)
Bypass AC input supply	30 (750)	30 (750)
UPS output AC	30 (750)	30 (750)
Neutral busbars—Input and Output	11 (280)	55 (1397)
Battery power	16 (400)	58 (1474)
Auxiliary cables: Monitor board (U2)	60 (1500)	20 (508)
Communications	55 (1400)	25 (635)
Ground	8 (197)	56 (14227)
Parallel Board	70 (1780)	20 (508)

Use wiring rated at 75°C or greater.

APPENDIX A - UPS STATUS MESSAGES

Table 44 shows all event messages as they appear in the current status area of the LCD or the history log, along with a description and recommended actions, if any. For further information on the current status area and the history log, see **2.11 - UPS Status Messages**.

Table 44 UPS status messages

Event Message	Description / Suggested Action (if any)
Inverter Comm. Fail	The RS485 communication between internal monitor and inverter fails. Contact the manufacturer at 800-543-2378 for assistance.
Rectifier Comm. Fail	The RS485 communication between internal monitor and rectifier fails. Contact the manufacturer at 800-543-2378 for assistance.
Parallel Comm. Fail	The CAN communication between different UPSs within a parallel system fails. <ol style="list-style-type: none"> 1. Check if there are some UPSes not powered on in the parallel system. If so, power on these UPSs and check if the alarm disappears. 2. Press Fault Clear push button. 3. If alarm does not clear, contact the manufacturer at 800-543-2378
Battery Overtemp.	The Battery temperature is over limit. Check the battery temperature and ventilation
Ambient Overtemp.	The Ambient temperature is over limit. Check the ventilation of UPS room.
Battery Fault	Battery is bad. (Reserved) Contact the manufacturer at 800-543-2378 for assistance.
Replace Battery	Battery should be replaced. Contact the manufacturer at 800-543-2378 for assistance.
Battery Low Pre-warning	Before the end of discharging, battery under-voltage pre-warning should occur. After this pre-warning, battery should have the capacity for 3 minutes discharging with full load. The time is user configured from 3 to 60 minutes. Shut down the load in time
Battery End of Discharge	Inverter turned off due to low battery voltage. Check the utility failure and try to recover it.
Mains Volt. Abnormal	Mains Voltage exceeds the upper or lower limit and results in rectifier shutdown. Check the input line-to-neutral voltage amplitude of rectifier.
Mains Undervoltage	Mains Voltage is undervoltage (120v~176v) with derated load. Check the input line-to-line voltage amplitude of rectifier.
Mains Freq. Abnormal	Mains frequency is out of limit range and results in rectifier shutdown. Check the rectifier's input voltage frequency
Battery Fuse Fail	Battery Fuse is open. Contact the manufacturer at 800-543-2378 for assistance.
Rectifier Fault	Rectifier Fault; Contact the manufacturer at 800-543-2378 for assistance.
Input Inductor Overtemp.	The temperature of rectifier inductor is too high to keep the rectifier running. Check the ambient temperature and ventilation; contact the manufacturer at 800-543-2378 for assistance.
Rectifier Overtemp.	The temperature of heat sink is too high to keep the rectifier running. The UPS can recover automatically. Check the environment and ventilation.
Charger Fault	The Charger is fault. Contact the manufacturer at 800-543-2378 for assistance.
Input Fuse Fail	Input fuse is open. Contact the manufacturer at 800-543-2378 for assistance.
Control Power 1 Fail	Control Power 1 has failed or has been lost. Contact the manufacturer at 800-543-2378 for assistance.
Mains Phase Reversed	Input phase sequence is inverse. Contact the manufacturer at 800-543-2378 for assistance.
Rectifier Overcurrent	The current of Rectifier is over limit. Contact the manufacturer at 800-543-2378 for assistance.
Soft Start Fail	Rectifier could not start due to low DC bus voltage. Contact the manufacturer at 800-543-2378 for assistance.

Table 44 UPS status messages (continued)

Event Message	Description / Suggested Action (if any)
Bypass Unable to Trace	<p>This alarm is triggered by an inverter software routine when the amplitude or frequency of bypass voltage is beyond the normal range. The amplitude threshold is fixed for positive and negative 10% rating. This alarm automatically resets once the bypass voltage goes normal.</p> <ol style="list-style-type: none"> 1. First verify that the bypass voltage and frequency displayed on the panel is within the selected range. Note here the rated voltage and frequency are specified by "Output voltage level" and "Output frequency level" respectively. 2. If the displayed voltage is believed to be abnormal, then verify the bypass voltage and frequency presented to the UPS. Check the external supply if it is found to be faulty. Contact the manufacturer at 800-543-2378 for assistance.
Bypass Abnormal	<p>This alarm is triggered by an inverter software routine when the amplitude or frequency of bypass voltage exceeds the limit. This alarm automatically resets once the bypass voltage goes normal. First check if there are some relevant alarms such as "Bypass disconnect open", "Bypass phase reverse" and "Mains neutral lost". If they appear, solve them first.</p> <ol style="list-style-type: none"> 1. Then verify that the bypass voltage and frequency displayed on the panel is within the bypass limit. Note here the rated voltage and frequency are specified by "Output voltage level" and "Output frequency level" respectively. 2. If the displayed voltage is believed to be abnormal, then verify the bypass voltage and frequency presented to the UPS. Check the external bypass supply if it is found to be faulty. If the utility is likely to trigger this alarm frequently, the bypass limit can be changed a little larger through the configuration software according to the customer's agreement. Contact the manufacturer at 800-543-2378 for assistance.
Inverter Asynchronous	<p>This alarm is triggered by an inverter software routine when the inverter and bypass waveforms are misaligned by more than 6 degrees in phase. This alarm resets automatically once the condition is no longer true.</p> <ol style="list-style-type: none"> 1. First check if the alarm "Bypass unable to trace" or "Bypass abnormal" occurs. If so, solve it first. 2. Verify the waveform of the bypass voltage. If it is too distorted, ask the customer to verify and seek any possible measurements. Contact the manufacturer at 800-543-2378 for assistance.
Inverter Fault	<p>This alarm indicates a fault condition exists within the inverter. Contact the manufacturer at 800-543-2378 for assistance.</p>
Inv. Inductor Overtemp.	<p>The temperature of the output filter inductor is too high to keep inverter running. This alarm is triggered by the signal from a thermostat mounted in the output filter inductor. The UPS would recover automatically after a 5 minute delay from the disappearance of the overtemperature signal. If the overtemperature condition is true then check for and verify:</p> <ol style="list-style-type: none"> 1. high ambient air temperature. 2. blocked cooling airway. 3. any fan failure. 4. prolonged inverter overload. Contact the manufacturer at 800-543-2378 for assistance.
Inverter Overtemp.	<p>The temperature of the inverter heat sink is too high to keep inverter running. This alarm is triggered by the signal from a temperature monitoring thermostat on the inverter bridge heat sink. The UPS will recover automatically after a 5 minute delay from the disappearance of the overtemperature signal. If the overtemperature condition is true, then check for and verify:</p> <ol style="list-style-type: none"> 1. high ambient air temperature. 2. blocked cooling airway. 3. any fan failure. 4. prolonged inverter overload. Contact the manufacturer at 800-543-2378 for assistance.
Fan Fault	<p>At least one of the cooling fans fails. Contact the manufacturer at 800-543-2378 for assistance.</p>
Inverter STS Fail	<p>At least one of the static switches of inverter side is open or short circuit. This fault is locked until power off. Contact the manufacturer at 800-543-2378 for assistance.</p>
Bypass STS Fail	<p>At least one of the static switches of bypass side is open or short circuit. This fault is locked until power off. Contact the manufacturer at 800-543-2378 for assistance.</p>

Table 44 UPS status messages (continued)

Event Message	Description / Suggested Action (if any)
Inverter Contactor Fail	The Inverter contactor has failed. This alarm is triggered when the feedback signal and the state of the contactor is not identical for a specified time. Contact the manufacturer at 800-543-2378 for assistance.
Output Fuse Fail	At least one of the output fuses is open. Contact the manufacturer at 800-543-2378 for assistance.
Control Power 2 Fail	Control Power 2 is abnormal or lost. Contact the manufacturer at 800-543-2378 for assistance.
Unit Overload	The UPS is confirmed to be overload when the load arises above 105% nominal rating. The alarm automatically resets once the overload condition is removed. 1. Confirm that the alarm is true by checking the load percent indicated on the LCD panel to determine which phase is being overloaded. 2. If the alarm is true, measure the actual output current to verify that the indications are valid. Disconnect unnecessary load and ensure the safety. In a parallel system, a severe load sharing error can also leads to the alarm. Contact the manufacturer at 800-543-2378 for assistance.
System Overload	The UPS parallel system is confirmed to overload when the total load arises above 105% nominal rating for the set basic number of UPSs. The alarm automatically resets once the overload condition is removed. 1. Confirm that the alarm is true by checking the system load percent indicated on the LCD panel to determine which phase is being overloaded. 2. If the alarm is true, measure the actual output current to verify that the indications are valid. Disconnect unnecessary load and ensure the safety. In a parallel system, a severe load sharing error can also leads to the alarm.
Unit Overload Timeout	The UPS is confirmed to overload and the overload times out. Note 1: the highest loaded phase will indicate overload timing-out first. Note 2: When the timer is active then alarm "unit overload" should also be active as the load is above nominal. Note 3: When the timer has expired, the inverter Static Switch is opened and the load transferred to bypass. The inverter shutdown and will restart after 10 seconds. Note 4: If the load decreases lower than 95% after 5 minutes, the system will transfer back to inverter mode. Confirm that the alarm is genuine by checking the load percent indicated on the LCD. If an overload is indicated then check the load, and investigate any additional load connected prior to the alarm (if applicable).
Inverter Overcurrent	The current of inverter IGBT is over limit. If the fault will not reset, contact the manufacturer at 800-543-2378 for assistance.
Bypass Phase Reversed	The phase sequence direction of bypass voltage is reversed. Normally, the phase of phase B lags 120 degrees behind phase A, and the phase of phase C lags 120 degrees behind phase B. Verify that the phase rotation of the bypass supply presented to the UPS is correct, and rectify it if it is found to be in error. Contact the manufacturer at 800-543-2378 for assistance.
Load Impact Transfer	A transfer to bypass occurred due to a large step load. The UPS should recover automatically. Turn on connected equipment in sequential order to reduce the step loading of the inverter.
Transfer Timeout	The load is on bypass power due to excessive number of transfers that occurred within the last hour. The UPS will recover automatically and will transfer the load back to inverter power within an hour.
Load Sharing Fault	UPS working within a parallel system are not sharing load current correctly. Contact the manufacturer at 800-543-2378 for assistance.
DC Bus Abnormal	Shut off inverter due to abnormal DC bus voltage. Contact the manufacturer at 800-543-2378 for assistance.
System Transfer	The whole paralleled UPS system transferred to bypass at the same time. This message will appear on the UPS which passive transfer to bypass.
Parallel Board Fault	Parallel board is not working correctly. Contact the manufacturer at 800-543-2378 for assistance.
DC Bus Overvoltage	Rectifier, inverter and battery converter were shutdown because DC bus voltage is too high. Check whether there is a fault in rectifier side. If no, then check whether overload occurs. Restart the inverter after resetting the fault. If fault does not clear, contact the manufacturer at 800-543-2378 for assistance.

Table 44 UPS status messages (continued)

Event Message	Description / Suggested Action (if any)
Parallel Connect Fault	The parallel cables are not connected correctly in a parallel system. 1. Reset the fault by pressing the "fault clear" button, then restart the inverter by pressing the "inverter on" button. 2. If the UPS does not resume normal operation, contact the manufacturer at 800-543-2378 for assistance.
Bypass Overcurrent	Bypass current is over limit above 135% rating. The UPS just alarms and does nothing. Refer to your installation documentation or contact the manufacturer at 800-543-2378 for assistance.
LBS Active	The LBS setting is active. The UPS is acting as an LBS master or slave in a dual bus configuration.
Battery ground fault	Battery ground fault from dry contact signal. Contact the manufacturer at 800-543-2378 for assistance.
Inverter turned On manually	Manual Turn On via front panel
Inverter turned Off manually	Manual Turn Off via front panel
EPO	Emergency Power Off
Transfer Confirm	Interrupted Transfer Confirm
Transfer Cancel	Interrupted Transfer is cancel
Unit Off Confirm	Unit Turned Off Confirm
System Off Confirm	Parallel System Turned Off Confirm
Fault Reset	Fault Rest
Alarm Silence	Alarm Silence
Turn On Fail	Turn On Fail
Alarm Reset	Audible Alarm Reset
Bypass Mode	UPS in Bypass Mode
Normal Mode	UPS in Normal Mode
Battery Mode	UPS in Battery Mode
Joint Mode	UPS in Inverter Mode
UPS Shutdown	UPS Shutdown, output power-down
Output Disabled	UPS Output Disabled
Generator Connected	Generator is connected and a signal is sent to UPS
Input Disconnect Open	Input Disconnect Open
Input Disconnect Closed	Input Disconnect Closed
Maint. Disconnect Open	Maintenance Disconnect Open
Maint. Disconnect Closed	Maintenance Disconnect Closed
Reserved	
Rotary Sw. Test Pos.	Rotary switch is in test position.
Rotary Sw. Normal Pos.	Rotary switch is in normal position.
Rotary Sw. Bypass Pos.	Rotary switch is in bypass position.
Rotary Sw. Maint. Pos.	Rotary switch is in maintenance position.
Bypass Disconnect Open	Bypass Disconnect Open
Bypass Disconnect Closed	Bypass Disconnect Closed
Output Disconnect Open	Output Disconnect Open
Output Disconnect Closed	Output Disconnect Closed
Battery Contactor Open	Battery Contactor Open
Battery Contactor Close	Battery Contactor Close
Battery Reverse	Connect the battery again and check the wiring of batteries
No Battery	Check the battery and the wiring of batteries

Table 44 UPS status messages (continued)

Event Message	Description / Suggested Action (if any)
Auto start	After UPS was shutdown at EOD, inverter auto starts when utility restore.
BCB closed	BCB closed from dry contact signal.
BCB open	BCB open from dry contact signal.
Battery Float Charging	Battery is float charging
Battery Boost Charging	Battery is boost charging
Battery Discharging	Battery is discharging
Battery Period Testing	Battery is period self-testing.
Batt. Capacity Testing	Battery is capacity self-testing.
Batt. Maint. Testing	Battery is maintenance self-testing.
UPS System Testing	UPS System is testing
Inverter in Setting	Inverter is in parameter setting
Rectifier in Setting	Rectifier is in parameter setting
Balancer Fault	Internal VDC (+) and VDC (-) offset by over 50V exceeding the inverter DC offset compensation capacity. Inverter shuts down. Load transfers to bypass.
Balancer Over Current	Internal Inverter DC offset balancing IGBT current rating exceeded 300%. Inverter shuts down. Load transfers to bypass.
Batt. Contactor Fail	Battery contactor or circuit breaker not responding to control signals.
Batt. Converter Fault	Battery converter output voltage beyond limits or battery fuse failed. Battery converter shuts down. Battery backup not available.
Batt. Conv. Over. Curr.	Battery converter overloaded. Battery converter shuts down. Battery backup not available.
Batt. Converter Overtemp.	Overheating of battery converter heatsinks. Battery converter shuts down. Battery backup not available.
Operation Invalid	This record is registered following an incorrect operation.
Byb. Abnormal Shutdown	Both bypass and inverter voltages unavailable. Load interruption.
Setting Save Error	History records not saved. (Reserved)
Mains Neutral Lost	AC Input mains reference neutral not detected.
Balancer overtemp.	Inverter voltage offset control choke overheated. Inverter shuts down. Load transfers to bypass.
Protocol version clash	Firmware incompatibility between monitor board and digital signal processor board.
MBP-T cabinet Fan Fault	Maintenance bypass cabinet fans fault.
Ext Input TX Overtemp	External input isolation transformer overtemperature
Ext Output TX Overtemp	External output isolation transformer overtemperature
Battery Room Alarm	Environment in Battery Room Needs Attention
Rec Flash Update	Rectifier firmware is being updated
Inv Flash Update	Inverter firmware is being updated
Monitor Flash Update	Monitor firmware is being updated
Input contactor fault	Input contactor fault
Contactor P.S. 1 fault	Contactor Power Supply board 1 Fault
Contactor P.S. 2 fault	Contactor Power Supply board 2 Fault
LBS abnormal	LBS is abnormal
DSP firmware error	The inverter firmware does not match the rectifier firmware.



While every precaution has been taken to ensure the accuracy and completeness of this literature, the manufacturer assumes no responsibility and disclaims all liability for damages resulting from use of this information or for any errors or omissions.

All rights reserved. Specifications subject to change without notice.
© Dual-Lite, Trident, the Dual-Lite logo and the Trident logo are registered trademarks of Hubbell Lighting, Inc.
© MultiLink and IntelliSlot are registered trademarks of Liebert Corp.
All names referred to are trademarks or registered trademarks of their respective owners.

93020448 10/08



HUBBELL LIGHTING, INC.