



Dual-Lite[®] TRX[™] Transformer Cabinet
User Manual—10-30kVA, 50/60Hz



Hubbell Lighting, Inc.

TABLE OF CONTENTS

IMPORTANT SAFETY INSTRUCTIONS	1
SAVE THESE INSTRUCTIONS	1
GLOSSARY OF SYMBOLS	5
1.0 DUAL-LITE TRX TRANSFORMER CABINET	6
1.1 Locating the Cabinet	6
1.2 Cable Installation	7
1.2.1 Wiring Preparation	7
1.2.2 Power Cable Installation	7
1.2.3 Input/Output Wiring	7
1.3 Bolting Cabinets Together	9
1.3.1 Floor Installation	10
1.3.2 Cable Entry	10
1.3.3 Optional Cabinets	10
2.0 INSTALLATION DRAWINGS	12
3.0 SPECIFICATIONS	17

FIGURES

Figure 1	Single input UPS with external Dual-Lite TRX transformer cabinet —Typical configuration . . .	6
Figure 2	Schematic - Dual-Lite TRX transformer cabinet to maintenance bypass cabinet	8
Figure 3	Bolting Dual-Lite TRX to a Dual-Lite transformer cabinet	9
Figure 4	Cabinet arrangement	10
Figure 5	Clearances—Front, side and rear	11
Figure 6	Dual-Lite TRX transformer cabinet main components	12
Figure 7	Busbars—Dual-Lite TRX transformer cabinet	12
Figure 8	Lineup arrangement, Dual-Lite TRX with Dual-Lite TRX transformer cabinet, 10-40kVA . . .	13
Figure 9	Lineup arrangement, Dual-Lite TRX with Dual-Lite TRX transformer cabinet, 60-100kVA . . .	13
Figure 10	Outline drawing, Dual-Lite TRX transformer cabinet for Dual-Lite TRX, 10-30kVA	14
Figure 11	Dual-Lite TRX transformer cabinet transformer location	15
Figure 12	Bend radius - Top feed power connections, 10-30kVA system	16

TABLES

Table 1	Wiring for Dual-Lite TRX transformer cabinet to Dual-Lite TRX	8
Table 2	Hardware torque values	16
Table 3	Physical standards and parameters	17
Table 4	Dual-Lite TRX transformer cabinet, 10-30kVA, mechanical characteristics	17
Table 5	Dual-Lite TRX transformer cabinet heat dissipation, both transformers, full load	17
Table 6	Recommended lug sizes (compression type) M10, 3/8" bolt	18
Table 7	Busbar torque for power wiring	18
Table 8	Terminal block torque with compression lugs for control wiring	18
Table 9	Electrical data—Dual-Lite TRX transformer cabinet, 480VAC input, 208VAC output, main input, with 480V:208V transformer	18
Table 10	Dual-Lite TRX transformer cabinet inrush multiplier	19
Table 11	Electrical data—Dual-Lite TRX transformer cabinet 208VAC input, 480VAC output, system output, with 208V:480V transformer	19

IMPORTANT SAFETY INSTRUCTIONS

SAVE THESE INSTRUCTIONS

This manual contains important instructions that should be followed during installation of the Dual-Lite TRX transformer cabinet.

Read this manual thoroughly, paying special attention to the sections that apply to your installation, before working with the UPS. **Retain this manual for use by installing personnel.**

A properly trained and qualified electrical contractor should oversee the installation of the equipment.

The Dual-Lite TRX transformer cabinet cannot be put into operation until it is commissioned by the manufacturer or authorized engineer. Otherwise, human safety may be endangered and damage to the UPS will not be covered by the warranty.

The Dual-Lite TRX transformer cabinet is designed for commercial and industrial uses and cannot be used as life support equipment.



WARNING

Risk of moving heavy equipment and electric shock. Can cause equipment damage, injury and death.

Exercise extreme care when handling UPS cabinets to avoid equipment damage or injury to personnel. The Dual-Lite TRX transformer cabinet's weight ranges from 785 to 1969 lb. (356 to 893kg).

Determine the unit's weight and locate the center of gravity symbols before handling the Dual-Lite TRX transformer cabinet.  Test lift and balance the cabinet before transporting it. Never tilt equipment more than 15 degrees from vertical.

In case of fire involving electrical equipment, use only carbon dioxide fire extinguishers or those approved for use in fighting electrical fires.

Extreme caution is required when performing maintenance.

Be constantly aware that the UPS system contains high DC as well as AC voltages.

Check for voltage with both AC and DC voltmeters prior to making contact.



AVERTISSEMENT

Risque lors du déplacement de l'équipement lourd et de décharge électrique pouvant entraîner des dommages matériels, des blessures et même la mort.

Faites preuve d'une extrême prudence lors de la manutention des armoires ASC afin d'éviter de les endommager ou de blesser le personnel. Les armoires Dual-Lite TRX transformer cabinet pèsent de 785 à 1969 lb (de 356 à 893 kg).

Déterminez le poids de l'unité et trouvez les symboles de centre de gravité avant de déplacer l'armoire Dual-Lite TRX transformer cabinet. Faites des essais de levage et d'équilibre avant de transporter l'armoire. N'inclinez jamais l'équipement à plus de 15 degrés à la verticale.

En cas d'incendie associé à du matériel électrique, n'utilisez que des extincteurs à dioxyde de carbone ou homologués pour la lutte contre les incendies d'origine électrique.

Les opérations d'entretien requièrent une extrême prudence.

Soyez toujours conscient du fait que le système ASC contient des tensions c.c. et c.a. élevées.

Vérifiez les tensions avec des voltmètres c.a. et c.c. avant d'établir tout contact.



WARNING

Risk of electric shock. Can cause equipment damage, injury and death.

As with other types of high power equipment, dangerous voltages are present within the UPS and battery enclosure even after input power has been disconnected. The risk of contact with these voltages is minimized as the live component parts are housed behind a metal panel. Further internal safety screens make the equipment protected to IP20 standards. Never remove panels or covers or open doors that will expose internal components to contact.

Read and follow all warnings, cautions and safety and operating instructions to avoid serious injury or death from electric shock. No risk exists to any personnel when operating the equipment in the normal manner, following the recommended operating procedures.

All equipment maintenance and servicing procedures involve internal access and should be carried out only by trained personnel.



AVERTISSEMENT

Risque de décharge électrique pouvant entraîner des dommages matériels, des blessures et même la mort.

À l'instar des autres types d'équipement haute puissance, des tensions dangereuses sont présentes à l'intérieur de l'armoire ASC et du châssis de batteries même après le débranchement de l'alimentation d'entrée. Le risque de contact avec ces tensions est diminué, car les parties de composants sous tension sont abritées derrière un panneau métallique. D'autres écrans de sécurité internes protègent l'équipement en conformité avec les normes IP20. Ne retirez jamais les panneaux ou les couvercles et n'ouvrez pas les portes donnant accès aux composants internes avec lesquels vous pouvez entrer en contact.

Veillez lire et suivre l'ensemble des avertissements, des mises en garde et des instructions de sécurité et de fonctionnement afin d'éviter des blessures graves, voire la mort, pouvant être causées par une décharge électrique. Il n'y a aucun risque pour le personnel lorsque l'équipement est utilisé normalement, en suivant les procédures de fonctionnement recommandées.

Toutes les procédures de réparation et d'entretien de l'équipement exigent un accès à l'intérieur de l'armoire et devraient être menées uniquement par du personnel compétent.

Ground Leakage Currents



WARNING

Risk of electric shock from high leakage current. Can cause injury, property damage and death.

EARTH CONNECTION IS ESSENTIAL BEFORE CONNECTING THE INPUT SUPPLY.

Earth leakage current exceeds 3.5 mA and is less than 1000 mA.

Transient and steady-state earth leakage currents, which may occur when starting the equipment, should be taken into account when selecting instantaneous RCCB or RCD devices.

Residual Current Circuit Breakers (RCCBs) must be selected sensitive to DC unidirectional pulses (Class A) and insensitive to transient current pulses.

Note also that the earth leakage currents of the load will be carried by this RCCB or RCD.

This equipment must be earthed in accordance with the local electrical code of practice.



AVERTISSEMENT

Risque de décharge électrique due à un courant de fuite élevé pouvant causer des blessures, des dommages matériels et même la mort.

IL EST PRIMORDIAL D'ASSURER UNE CONNEXION DE TERRE AVANT DE BRANCHER L'ALIMENTATION D'ENTRÉE. La fuite à la terre est supérieure à 3,5 mA et inférieure à 1 000 mA.

Vous devez tenir compte des fuites de courant transitoires et permanentes à la terre, susceptibles de se produire au démarrage de l'équipement, lors de la sélection des dispositifs DDFT instantanés.

Vous devez sélectionner des disjoncteurs différentiels de fuite à la terre (DDFT) sensibles aux impulsions unidirectionnelles c.c. (classe A) et insensibles aux impulsions de courant transitoires.

Notez également que les courants de fuite à la terre de la charge seront acheminés par ce dispositif DDFT.

Cet équipement doit être mis à la terre conformément au code national de l'électricité.



WARNING

Risk of electric shock. Can cause injury, property damage and death.

Under typical operation and with all UPS doors closed, only normal safety precautions are necessary. The area around the UPS system should be kept free of puddles of water, excess moisture and debris.

Special safety precautions are required for procedures involving handling, installation and maintenance of the UPS system and the internal batteries (internal batteries accommodated by the 10-40kVA frame only). Observe all safety precautions in this manual before handling or installing the UPS system as well as during all maintenance procedures. Observe all battery safety precautions before working on or near the battery.

This equipment contains several circuits that are energized with high voltage. Only test equipment designed for troubleshooting should be used. This is particularly true for oscilloscopes. Always check with AC and DC voltmeters to ensure safety before making contact or using tools. Even when the power is turned Off, dangerously high electric charges may exist within the UPS.

All power and control wiring should be installed by a qualified electrician. All power and control wiring must comply with the NEC and applicable local codes.

ONLY qualified service personnel should perform maintenance on the UPS system. When performing maintenance with any part of the equipment under power, service personnel and test equipment should be standing on rubber mats. The service personnel should wear insulating shoes for isolation from direct contact with the floor (earth ground).

Never work alone, even if all power is removed from the equipment. A second person should be standing by to assist and summon help in case an accident should occur.



AVERTISSEMENT

Risque de décharge électrique pouvant causer des blessures, des dommages matériels et même la mort.

Les précautions de sécurité habituelles suffisent lorsque le système ASC est en mode de fonctionnement normal et que toutes les portes sont fermées. La zone entourant le système ASC doit être exempte de flaques d'eau, d'humidité excessive et de débris.

Des précautions de sécurité spéciales sont requises pour les procédures associées à la manutention, à l'installation et à l'entretien du système ASC. Observez toutes les précautions de sécurité décrites dans le présent manuel avant de manipuler ou d'installer le système ASC, ainsi que pendant toutes les procédures d'entretien.

Cet équipement comporte plusieurs circuits à haute tension. Seuls des équipements d'essai conçus pour le dépannage doivent être utilisés. Cette mise en garde couvre notamment les oscilloscopes. Utilisez toujours des voltmètres c.a. et c.c. pour vérifier les tensions avant d'établir un contact ou d'utiliser des outils. Des tensions dangereusement élevées peuvent demeurer dans le système ASC même une fois l'alimentation coupée.

Tous les câbles d'alimentation et de contrôle doivent être installés par un électricien qualifié. Tous les câbles d'alimentation et de contrôle doivent être conformes au Code national de l'électricité des États-Unis (NEC) et celui du Canada, ainsi qu'aux codes locaux en vigueur.

L'entretien du système ASC ne doit être confié qu'à des professionnels qualifiés.

Les responsables de l'entretien et l'équipement d'essai doivent reposer sur des tapis de caoutchouc lors de toute intervention sur une pièce d'équipement sous tension. Les responsables de l'entretien doivent porter des chaussures isolantes pour prévenir tout contact direct avec le plancher.

Ne travaillez jamais seul, même si toute l'alimentation d'entrée est coupée de l'équipement. Une seconde personne devrait toujours être présente pour porter assistance ou chercher de l'aide en cas d'accident.

NOTICE

Risk of improper ground connection. Can cause equipment damage.

Ground connection is essential before connecting the input supply. This equipment must be grounded in accordance with local electrical codes. Maximum load must not exceed that shown on the UPS rating label.

NOTICE

Risk of improper electromagnetic shielding. Can cause radio communication interference.

This unit complies with the limits for a Class A digital device, pursuant to Part 15 Subpart J of the FCC rules. These limits provide reasonable protection against harmful interference in a commercial environment. This unit generates, uses and radiates radio frequency energy and, if not installed and used in accordance with this instruction manual, may cause harmful interference to radio communications. This unit is not designed for use in a residential area. Operation of this unit in a residential area may cause harmful interference that the user is solely responsible for correcting.

GLOSSARY OF SYMBOLS



Risk of electrical shock



Indicates caution followed by important instructions

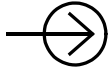

AC input



AC output



Requests the user to consult the manual

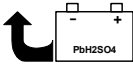

Indicates the unit contains a valve-regulated lead acid battery



Recycle



DC voltage



AC voltage



Equipment grounding conductor



Bonded to ground

1.0 DUAL-LITE TRX TRANSFORMER CABINET

The Dual-Lite TRX transformer cabinet offers 10-30kVA capacities offer 480V input and 480/277V output voltage transformation for single input configurations.

Figure 1 Single input UPS with external Dual-Lite TRX transformer cabinet —Typical configuration

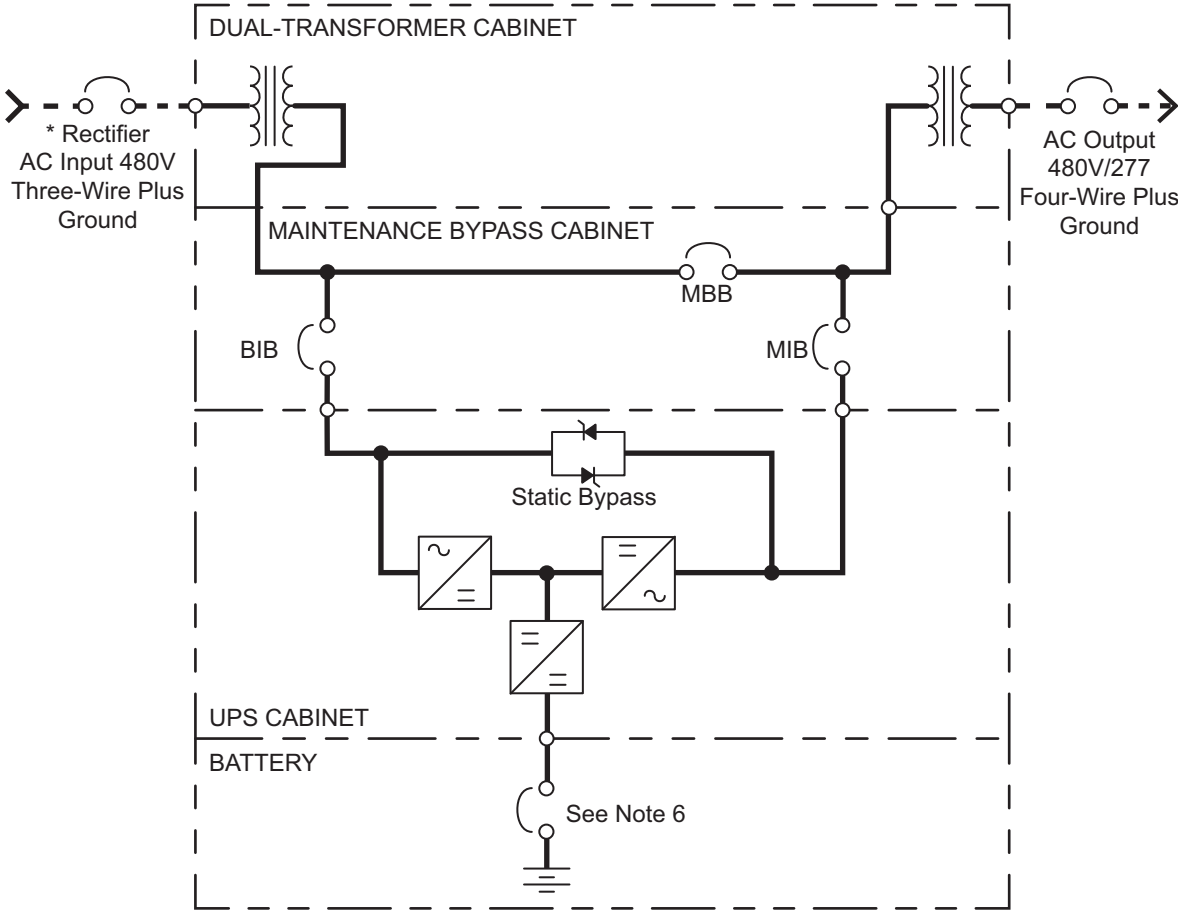

1. Install in accordance with national and local electrical codes.
2. Input and bypass must share the same single source.
3. A neutral is required from the system AC input source.
A full-capacity neutral conductor is recommended.
Grounding conductors are recommended.
4. Bypass and rectifier inputs and output cables must be run in separate conduits.
5. Control wiring must be run in separate conduits.
6. Internal battery breaker is optional on UPS with internal batteries. Battery breaker is factory-supplied with external Dual-Lite battery cabinets.

- BIB - Bypass Isolation Breaker
- MBB - Maintenance Bypass Breaker
- MIB - Maintenance Isolation Breaker

* External Overcurrent Protection by Others
Field-Supplied Wiring - - - -

1.1 Locating the Cabinet

This Dual-Lite TRX transformer cabinet may be mounted to the right of the UPS. Ensure that the unit is in a well-ventilated area and that there is clearance for access to the switches and cable connections as required by national and local codes.

1.2 Cable Installation

1.2.1 Wiring Preparation

Be sure that the unit is not connected to any AC utility power source or UPS before installing any wiring to this unit. This Dual-Lite TRX transformer cabinet should be installed by a qualified / certified electrician.



WARNING

Risk of electrical shock and arc flash. Can cause property damage, injury and death.

Read this section thoroughly before attempting to install wiring to this unit. Read and comply with all warnings and cautions in this manual.

Removing the Cover Plates

Plates cover the input and output terminals on the front of the Dual-Lite TRX transformer cabinet (see **Figure 7**). Remove these and keep the screws and plates for reinstallation.

1.2.2 Power Cable Installation

Refer to **Table 42** when selecting cables. Refer to the electrical tables listed in the back of this manual.



NOTE

Transient and steady state earth leakage currents may occur when starting the equipment. This should be taken into account when selecting ground current detection devices because these will carry the earth leakage currents of both the UPS equipment and the load.

1.2.3 Input/Output Wiring

Follow the steps below to connect the input wiring:



NOTE

Input wiring must be installed using conduit if cabinet is not mounted to the immediate right of the UPS.

1. Locate the input wiring access (top or bottom access), remove the conduit landing plate and punch the appropriate size hole for the size conduit being used. Pull the three/four input wires through the hole, allowing some slack for installation. For cabinets that are located to the immediate left of the UPS, the access plate is on the lower right of the cabinet. Remove the access plate and verify that the edge guarding is installed and intact.
2. Secure the conduit to the access plate of the Dual-Lite TRX transformer cabinet.
3. Input power cables connect to the transformer cabinet at TB1 and TB2; refer to **Figure 6, Table 1**.
4. Connect the ground cable from sources #1 and #2 to the transformer cabinet ground busbar and tighten them to 192 lb-in (22Nm) for M10 bolt.
5. Connect the neutral cable from sources #1 and #2 to the transformer cabinet neutral busbar and tighten it to 192 lb-in (22Nm) for M10 bolt.



NOTE

If the Dual-Lite TRX transformer cabinet is not to be bolted to the UPS, use either top or bottom access plate.

6. Connect the source #1 cables to TB1 (A-B-C) and tighten the connections to 192 lb-in (22Nm) for M10 bolt.
7. Connect the GEC from the Dual-Lite TRX transformer cabinet to the customer GEC and tighten the connections to 192 lb-in (22Nm) for M10 bolt.
8. Connect the neutral cable between the Dual-Lite TRX transformer cabinet and UPS and tighten the connections to 192 lb-in (22Nm) for M10 bolt.
9. Connect the ground cable between the Dual-Lite TRX transformer cabinet and UPS and tighten the connections to 192 lb-in (22Nm) for M10 bolt.

NOTICE

Risk of improper wiring connection. Can cause equipment damage.

The control wire must be installed to ensure proper operation of the system and fully protect the load when switching between bypass cabinet and UPS.

NOTES

1. All interconnection hardware supplied by Hubbell.
2. AC connections must be made to the UPS module before attaching Dual-Lite TRX transformer cabinet to UPS module.
3. Dual-Lite TRX transformer cabinet's must attach to the right side only of the Dual-Lite TRX UPS.
4. Refer to the individual drawing of each piece of equipment for additional details.

Table 1 Wiring for Dual-Lite TRX transformer cabinet to Dual-Lite TRX

Run	From	To	Conductors
A	Utility Source #1	Transformer Cabinet Main Input TB1	Phase A, B, C
B	Utility Neutral #1	Transformer Cabinet Neutral Busbar	Neutral
C	Utility Ground #1	Transformer Cabinet Ground Busbar	Ground
H	Transformer Cabinet GEC	Customer GEC	GEC

Figure 2 Schematic - Dual-Lite TRX transformer cabinet to maintenance bypass cabinet

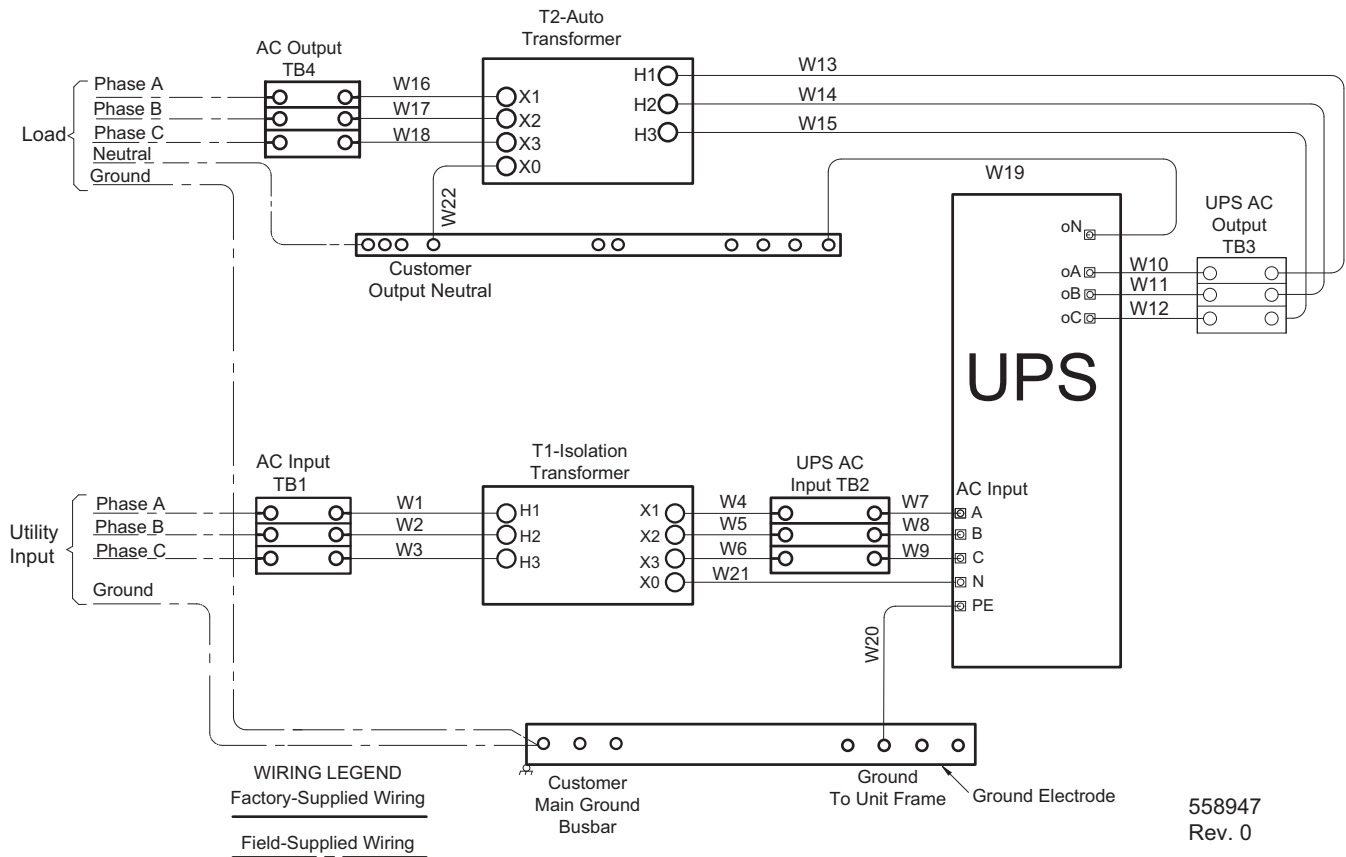

1.3 Bolting Cabinets Together



NOTE

UPS wiring must be completed before the cabinets are bolted together.

1. Line up cabinets so that mounting holes are aligned.

Figure 3 Bolting Dual-Lite TRX to a Dual-Lite transformer cabinet

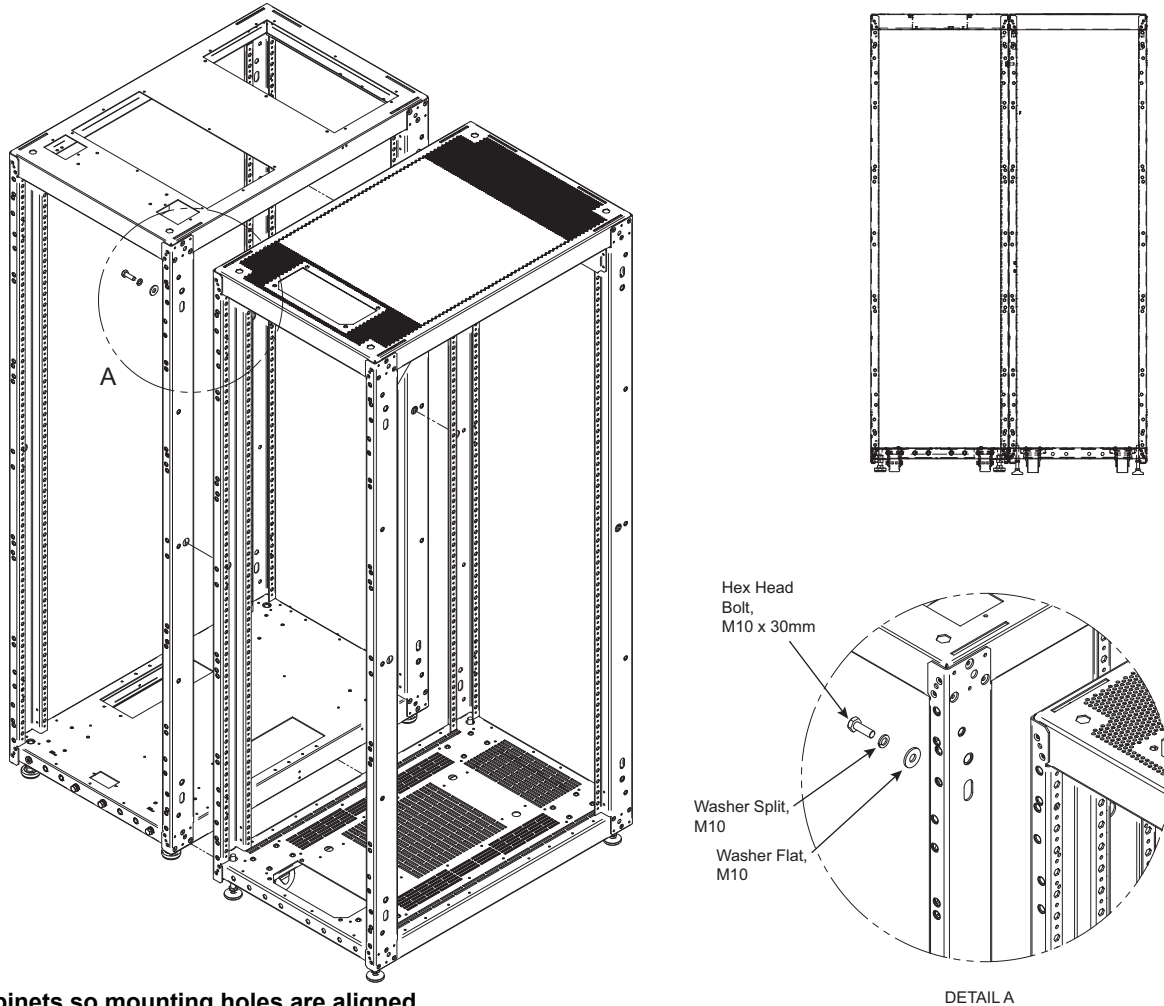

Place cabinets so mounting holes are aligned. A bolt from the adjacent cabinet may be screwed into the threaded top hole, or a bolt may be inserted through the lower hole and screwed into the threaded hole in the adjacent cabinet.

2. Using supplied hardware, bolt the cabinets together. The bolts may be inserted from either the UPS side or from the Dual-Lite TRX transformer cabinet side, whichever is more convenient.



WARNING

Risk of heavy units tipping over while being moved. Can cause property damage, injury and death.

The Dual-Lite transformer cabinet and battery cabinets must be properly prepared and secured for lifting. Improper lifting may cause the cabinets to fall, causing equipment damage, personal injury and death.

Hubbell recommends lifting the units with one of the following methods:

- Installing four eyebolts in the factory-fabricated holes, one at each corner of the unit, attaching cables or similar strapping to the eyebolts and lifting with a suitable mechanism.
- Placing suitable straps on the Dual-Lite TRX transformer cabinet. The straps must go under the unit to be lifted.



AVERTISSEMENT

Le centre de gravité élevé des appareils présente un risque de renversement lors des déplacements, pouvant entraîner des dommages matériels, des blessures et même la mort.

Les armoires Dual-Lite TRX transformer cabinet et de batterie doivent être correctement préparées et sécurisées avant d'être levées. Un mauvais levage peut faire tomber les armoires, causant des dommages à l'équipement, des blessures, voire la mort.

Hubbell recommande de soulever les unités en suivant l'une des méthodes suivantes :

- En installant quatre anneaux de levage dans les ouvertures fabriquées en usine, avec un anneau dans chaque coin de l'appareil, pour ensuite fixer les câbles ou sangles aux anneaux afin d'effectuer le levage à l'aide d'un mécanisme approprié.
- En plaçant des sangles convenables sur l'armoire Dual-Lite ou de batterie. Les sangles doivent passer sous l'unité à soulever.

1.3.1 Floor Installation

If the Dual-Lite TRX transformer cabinet is to be placed on a raised floor, the UPS should be mounted on a pedestal that will support the equipment point loading. Refer to the Dual-Lite TRX UPS manual, SL-25648 or SL-25650, to design this pedestal.

1.3.2 Cable Entry

Cables can enter the Dual-Lite TRX transformer cabinet from the top or bottom through removable metal plates.

Some plates have factory-punched holes and others are designed to allow the personnel to punch holes for fitting and securing the conduit. Once the conduit holes are punched, these plates should be reattached to the UPS. The conduit size and wiring method must be in accordance with all local, regional and national codes and regulations, including NEC ANSI/NFPA 70.



NOTE

When installing the UPS, the customer must provide a disconnect with overcurrent protection at the output of the UPS.

1.3.3 Optional Cabinets

The Dual-Lite TRX transformer cabinet must be bolted to right side of the Dual-Lite TRX (see **Figure 4**).

The Dual-Lite TRX transformer cabinet must be cabled and bolted to the Dual-Lite TRX **before** the UPS and bypass distribution cabinet are moved into their final position. Connect input wiring to the Dual-Lite TRX transformer cabinet **ONLY** after the units are internally cabled and positioned.

Battery cabinets may be bolted only to the left side of the Dual-Lite TRX; see **Figure 4**.

Figure 4 Cabinet arrangement

ALL UNITS VIEWED FROM ABOVE

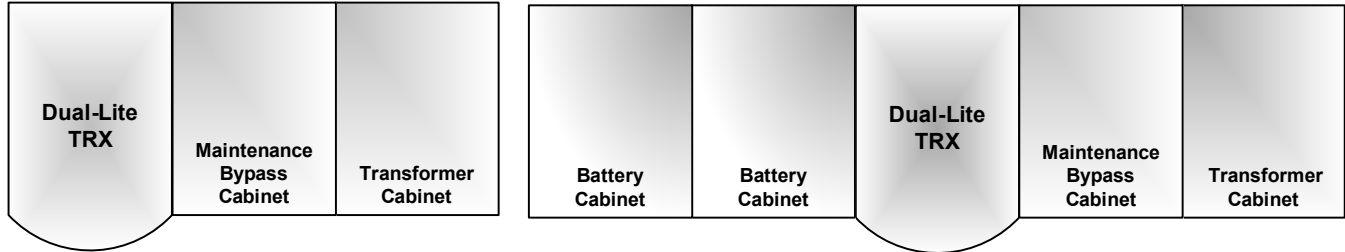

Dual-Lite TRX UPS connected to Dual-Lite TRX transformer cabinet and Maintenance Bypass Cabinet (The Dual-Lite TRX transformer cabinet must be on right side of the Dual-Lite TRX UPS)

Dual-Lite TRX UPS connected to Dual-Lite TRX transformer cabinet and Battery Cabinets and Maintenance Bypass Cabinet (transformer cabinet must be on right side of the Dual-Lite TRX) (Battery Cabinets must be on the left side of the Dual-Lite TRX UPS)

Figure 5 Clearances—Front, side and rear

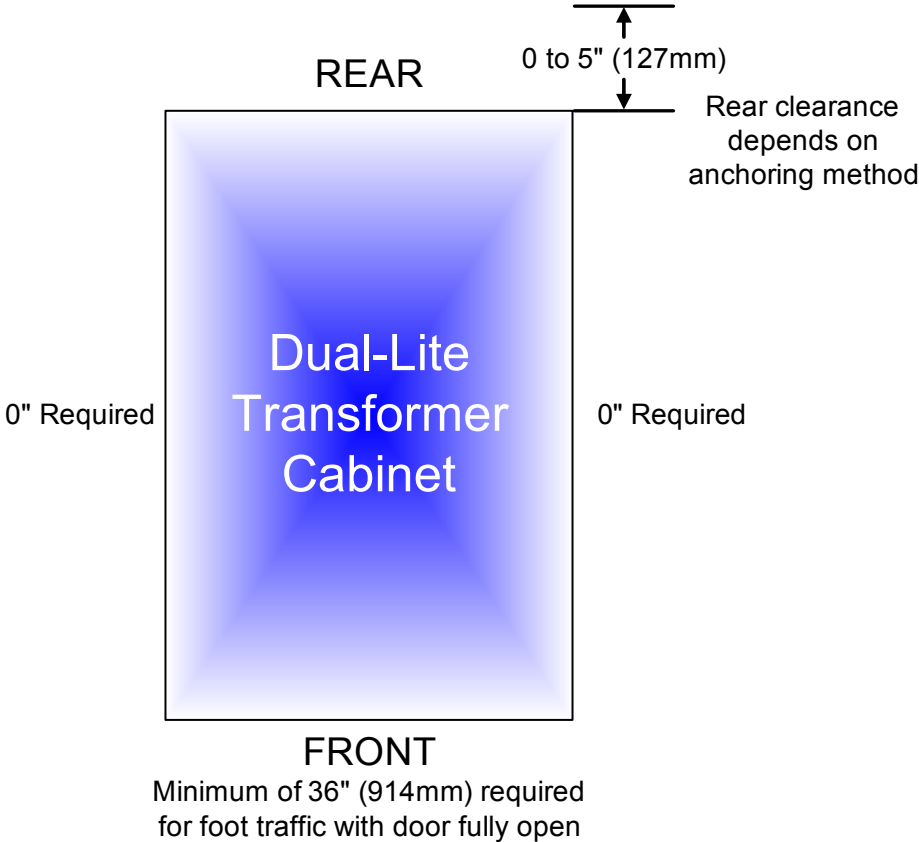

2.0 INSTALLATION DRAWINGS

Figure 6 Dual-Lite TRX transformer cabinet main components

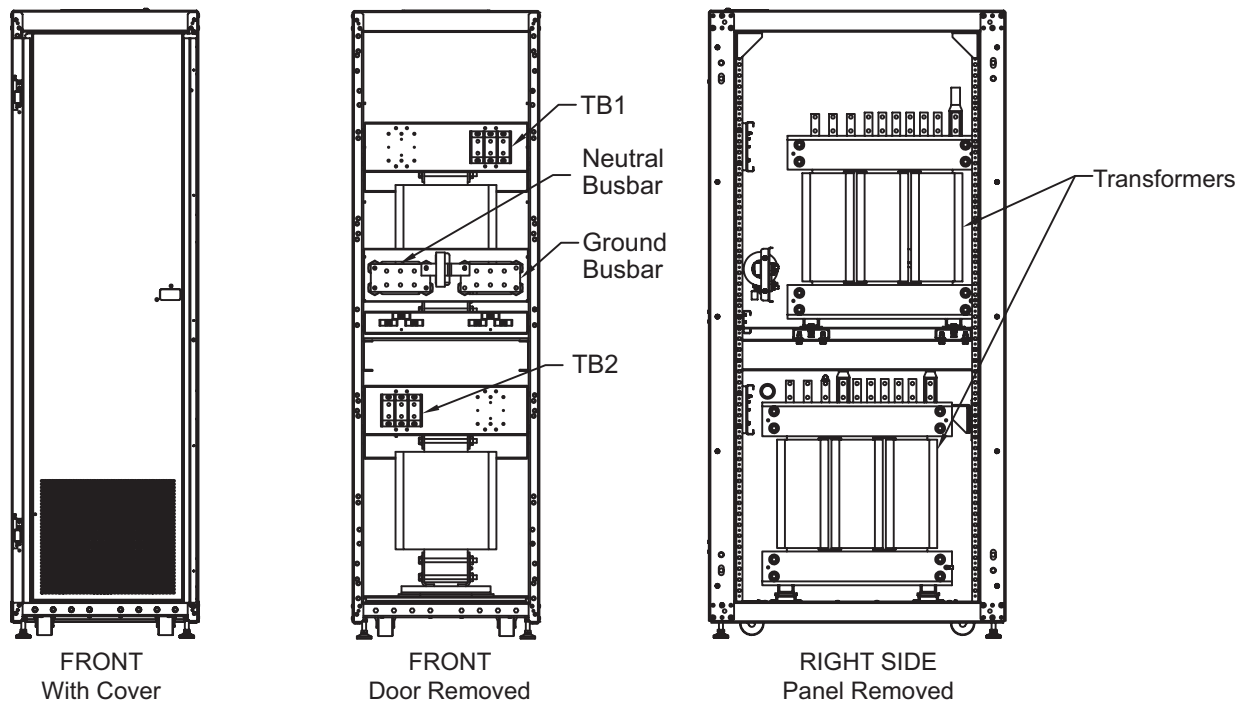

Figure 7 Busbars—Dual-Lite TRX transformer cabinet

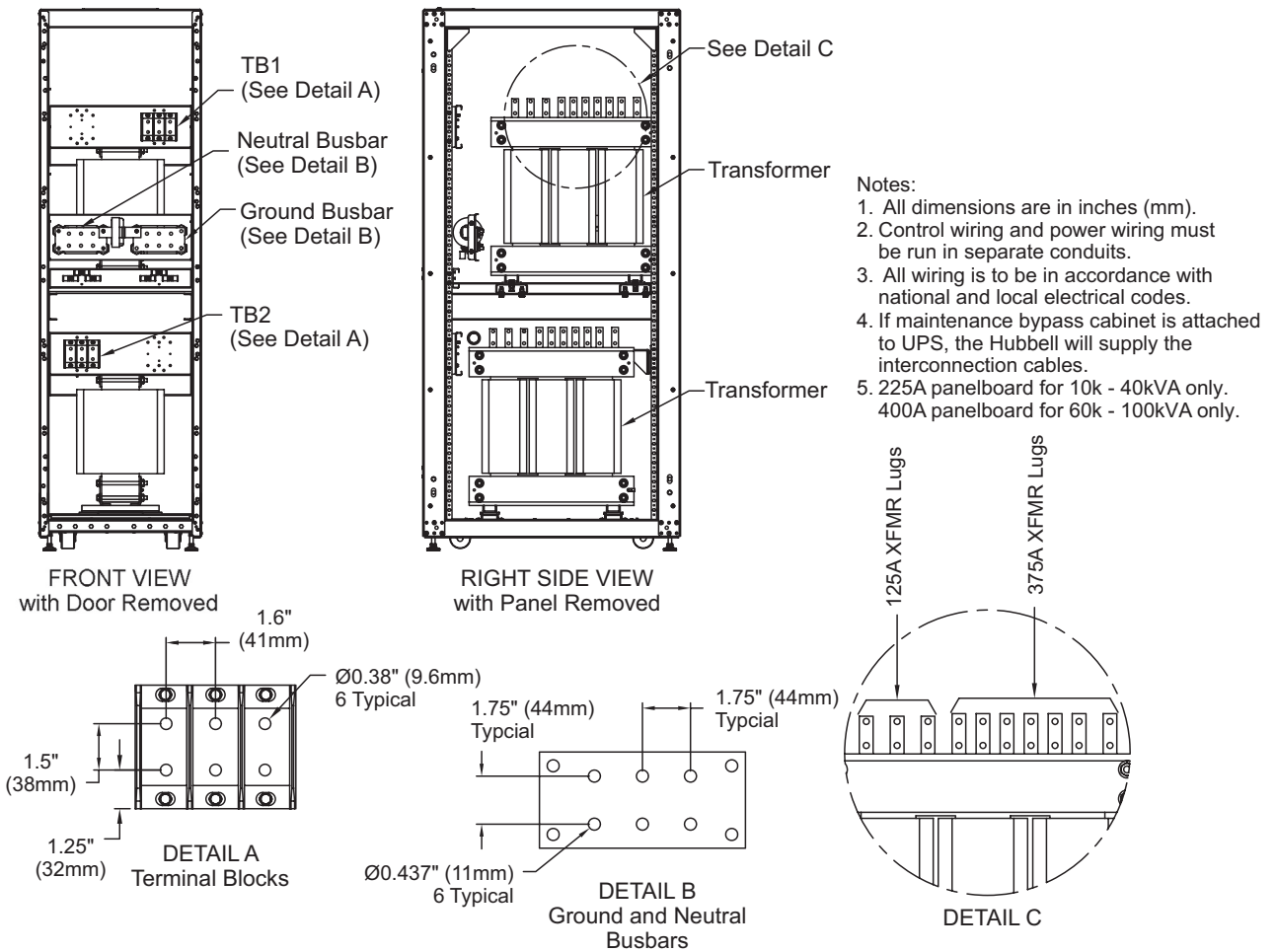
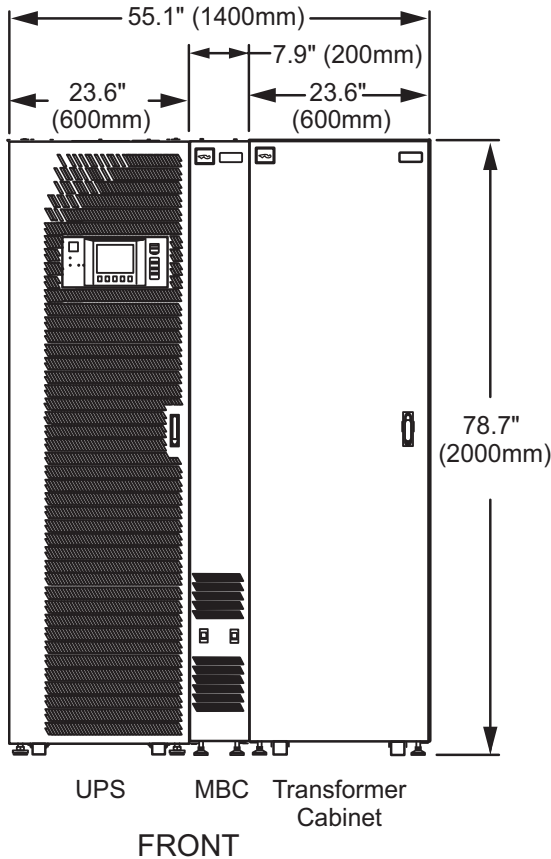

Figure 8 Lineup arrangement, Dual-Lite TRX with Dual-Lite TRX transformer cabinet, 10-40kVA



Notes:

1. 24" (610) minimum clearance above unit for air exhaust; 36" (914) front access required for service.
2. Keep cabinet within 15 degrees of vertical.
3. Top and bottom cable entry available through removable access plates. Remove, punch to suit conduit size and replace.
4. Unit bottom is structurally adequate for forklift handling.
5. Control wiring and power wiring must be run in separate conduits.
6. All wiring is to be in accordance with national and local electrical codes.
7. All battery cabinets must be positioned on the left side of the UPS.

Figure 9 Lineup arrangement, Dual-Lite TRX with Dual-Lite TRX transformer cabinet, 60-100kVA

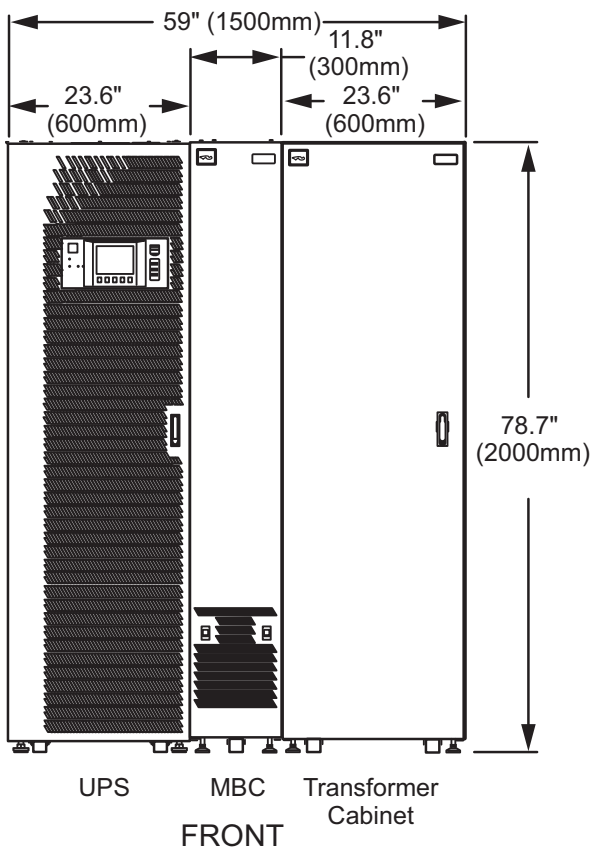

Notes:

1. All dimensions are in inches (mm).
2. 24" (610) minimum clearance above unit for air exhaust 36" (914) front access required for service.
3. Keep cabinet within 15 degrees of vertical.
4. Top and bottom cable entry available through removable access plates. Remove, punch to suit conduit size and replace.
5. Unit bottom is structurally adequate for forklift handling.
6. Control wiring and power wiring must be run in separate conduits.
7. All wiring is to be in accordance with national and local electrical codes.
8. All battery cabinets must be positioned on the left side of the UPS.

Figure 10 Outline drawing, Dual-Lite TRX transformer cabinet for Dual-Lite TRX, 10-30kVA

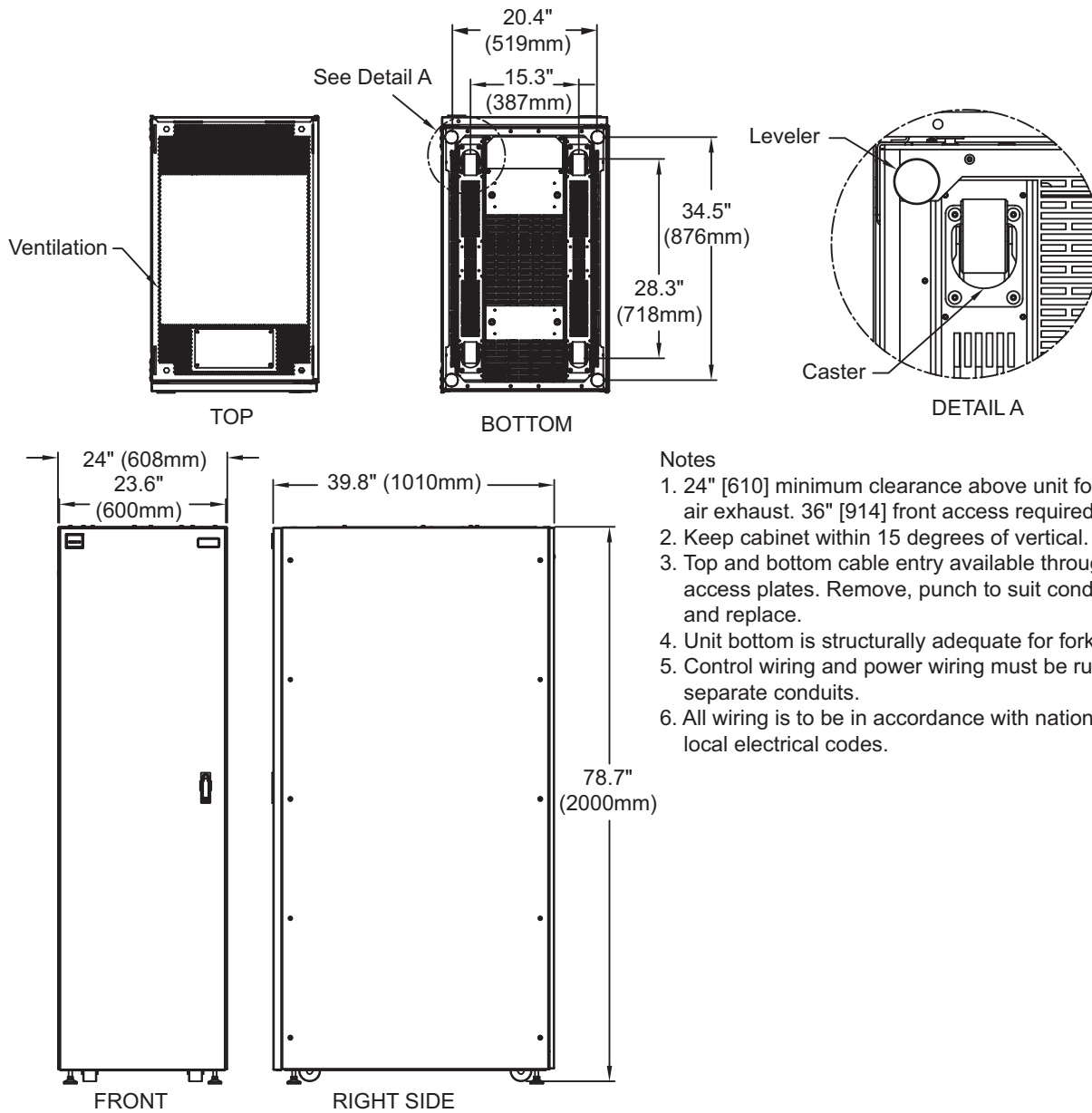

Notes

1. 24" [610] minimum clearance above unit for air exhaust. 36" [914] front access required for service.
2. Keep cabinet within 15 degrees of vertical.
3. Top and bottom cable entry available through removable access plates. Remove, punch to suit conduit size and replace.
4. Unit bottom is structurally adequate for forklift handling.
5. Control wiring and power wiring must be run in separate conduits.
6. All wiring is to be in accordance with national and local electrical codes.

Figure 11 Dual-Lite TRX transformer cabinet transformer location

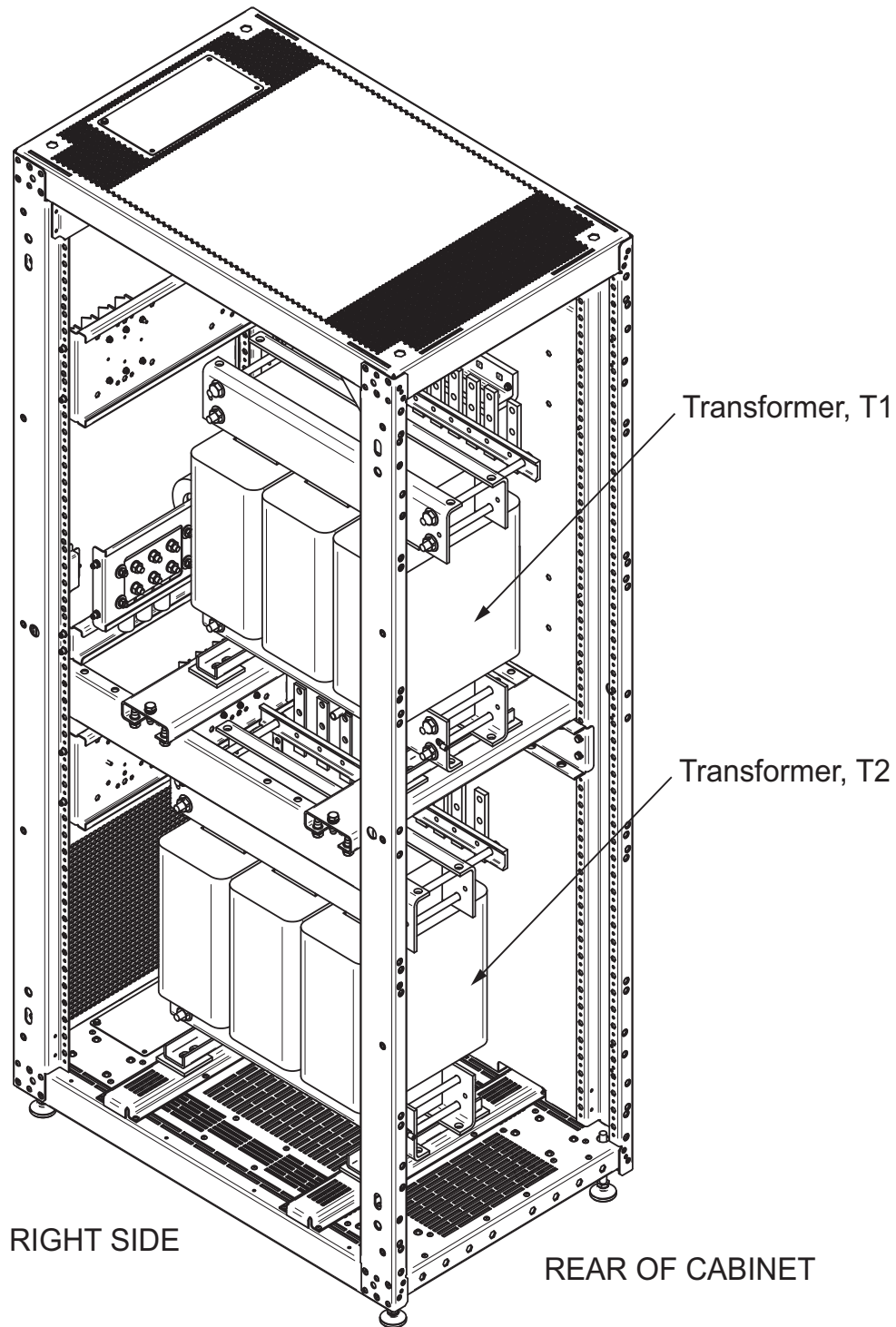
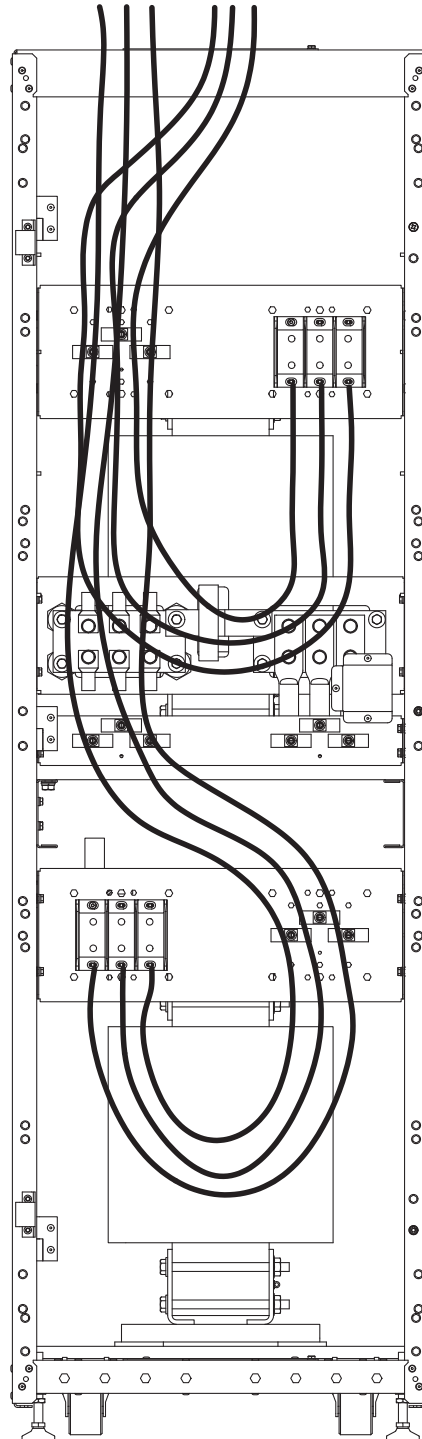

Figure 12 Bend radius - Top feed power connections, 10-30kVA system



NOTE

Interconnection wiring between the UPS and bypass distribution cabinet is supplied by Hubbell when the Dual-Lite TRX transformer cabinet and Dual-Lite TRX UPS are ordered as a system.

Table 2 Hardware torque values

Hardware	Two Belleville Washers
M10 (3/8")	240 lb-in. (27 Nm)
M12 (1/2")	428 lb-in (48Nm)

3.0 SPECIFICATIONS

Table 3 Physical standards and parameters

Dual Transformer Cabinet Parameters	Values
Standard Color	Black (ZP-7021)
Front Door Opening (for serviceability)	More than 180°
Degree of Protection for UPS Enclosure	IP 20 (with and without front door open)
Minimum Clearance, Top	24" (610mm)
Minimum Clearance, Back	0" (5" [127mm] when seismic brackets are used)
Minimum Clearance, Sides	0"
Cable Entrance	Top or Bottom
Standards & Conformities	UL 71778 5th Ed.; CSA 22.2 107.3-14 ISTA Procedure 1H; WEEE
Environmental	
Storage Temperature Range, °F (°C)	-13°F to 158°F (-25°C to 70°C)
Operating Temperature Range, °F (°C)	32°F to 104°F (0 to 40°C) 32°F to 86°F (0-30°C) when seismic brackets are used
Relative Humidity	Up to 95% Non-Condensing (Operating and Non-Operating)
Maximum Altitude Above MSL, ft (m)	4920 (1500) (as per IEC 62040/3) - 1% Maximum kW derate / 100m rise between 1500-3000m

Table 4 Dual-Lite TRX transformer cabinet, 10-30kVA, mechanical characteristics

Mechanical Characteristics	Values
Dimensions, W x D x H, in (mm)	23.625 x 39.375 x 78.75 (600 x 1000 x 2000)
Color	ZP-7021 (Black)
Protection Degree IEC (60529)	IP20 (finger-proof with front doors open or closed)
Rated Power, kVA	Weight, lb (kg)
10	827 (376)
15	883 (401)
20	941 (428)
30	1280 (582)

Table 5 Dual-Lite TRX transformer cabinet heat dissipation, both transformers, full load

Dual-Lite TRX Transformer Cabinet Rating, kVA	Dual-Lite TRX Transformer Cabinet Heat Dissipation 480:480 Transformer BTU/Hr (kW)
10	3276 (0.96)
15	4026 (1.18)
20	5466 (1.60)
30	9896 (2.89)

NOTE

The breakers and cables used must be in accordance with NEC ANSI/NFPA 70. A disconnect breaker must be provided for rectifier and bypass inputs. Recommended cable sizes are suitable for operation at a maximum temperature of 104°F (40°C).

Table 6 Recommended lug sizes (compression type) M10, 3/8" bolt

Cable Size	T&B Copper Two Hole	T&B Aluminum Two Hole
#6AWG	256-030695-868	—
#4AWG	256-030695-733	—
#2-3AWG	54811BE	—
#1AWG	54857BE	—
#1/0AWG	256-30695-593	—
#2/0AWG	54862BE	60238
#3/0AWG	54864BE	60244
#4/0AWG	54866BE	60250
250kcmil	54868BE	60256
300kcmil	54870BE	60262
350kcmil	54872BE	60267
400kcmil	54874BE	60269
500kcmil	54876BE	60273
600kcmil	54878BE	60275
700kcmil	54879BE	60277
750kcmil	54880BE	60278

Table 7 Busbar torque for power wiring

Bolt Shaft Size	Torque Lb-in (Nm)
3/8" (M10)	192 (22)
1/2" (M12)	428 (48)

Table 8 Terminal block torque with compression lugs for control wiring

AWG Wire Size or Range	Torque Lb-in (Nm)
#22 - #14	3.5 to 5.3 (0.4 to 0.6)

**NOTE**

Refer to the manufacturer's data for proper torque for circuit breaker power connections.

Table 9 Electrical data—Dual-Lite TRX transformer cabinet, 480VAC input, 208VAC output, main input, with 480V:208V transformer

Dual-Lite TRX Transformer Cabinet Rating, kVA	Maximum Rectifier Input Current, A	Phase	Recommended Upstream Protection, A	75°C Wire Current A Total	Copper Wire	Aluminum Wire	Bolt Size
10	15	3W + G	20	40	(1) #8	(1) #8	M10
15	23	3W + G	30	40	(1) #8	(1) #8	M10
20	31	3W + G	40	40	(1) #8	(1) #8	M10
30	46	3W + G	60	65	(1) #6	(1) #4	M10

See Notes on Tables on page 19.

Table 10 Electrical data—Dual-Lite TRX transformer cabinet 208VAC input, 480VAC output, system output, with 208V:480V transformer

Dual-Lite TRX Transformer Cabinet Rating, kVA	Maximum System Output Current, A	Phase	Recommended Output Protection, A	75°C Wire Current A Total	Copper Wire	Aluminum Wire	Bolt Size
10	12	3W + G	15	40	(1) #8	(1) #8	M10
15	17	3W + G	25	40	(1) #8	(1) #8	M10
20	23	3W + G	30	40	(1) #8	(1) #8	M10
30	35	3W + G	45	65	(1) #6	(1) #4	M10

See Notes on Tables on page 19.

Table 11 Dual-Lite TRX transformer cabinet inrush multiplier

Dual-Lite TRX Transformer Cabinet Rating, kVA	Transformer Cabinet 480V:208V
10	11.7
15	11.3
20	7.8
30	7.4

Note: Inrush Current = NFLA x Table Value

Notes on Tables

Notes apply to **Tables 9** and **10**.

- Nominal input current (considered continuous) is based on full rated output load maximum current includes nominal input current and maximum battery recharge current (considered noncontinuous). Continuous and noncontinuous current are defined in NEC 100. Recommended overcurrent protection is based on 80% rated devices.
*The recommended overcurrent protection represents 125% of nominal full load current (continuous) per NEC 215.
- Maximum input current is controlled by the current limit setting.
- Recommended AC input external overcurrent protection is based on 80% rated devices and maximum input current limit setting.
- Recommended AC output external overcurrent protection is based on 80% rated devices and full rated output current.
- Input power factor of 0.99 is used for the calculations.



Dual-Lite® TRX™ UPS

User Manual—10-30kVA, 50/60Hz

DL-25655_REVO_08-16



Hubbell Lighting, Inc.