

Service Manual

**Indoor**  
 AW09ES2VHA  
 AW12ES2VHA  
 AW18ES2VHA  
 AW24ES2VHA

**Outdoor**  
 1U09ES2VHA  
 1U12ES2VHA  
 1U18ES2VHA  
 1U24ES2VHA

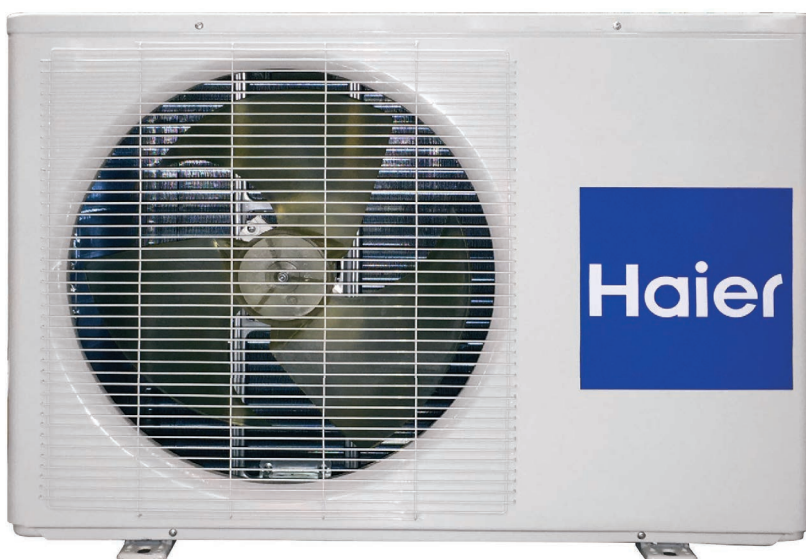

*Design may vary by model number.*

- Please read this manual before using the air conditioner.
- **Keep this user manual for future reference.**

### Table of Contents

Safety Precautions/Introduction.....	3
Outdoor Unit Controls and Components .....	7
Indoor Unit Controls and Components .....	13
Remote Control Functions.....	19
Sequence Of Operation .....	25
Installation.....	33
Error Codes and Problem Solving .....	43
Reference Information .....	55

*[This page intentionally left blank.]*

Table of Contents

**Safety Precautions** ..... 4  
    *Warning and Cautions* ..... 4  
**Introduction to System** ..... 5  
    *Specifications for proper operation should be followed*..... 5  
    *Fundamental Theory Of How System Works*..... 5

## Safety Precautions

- Read these Safety Precautions carefully to ensure correct installation.
- This manual classifies the precautions into WARNING and CAUTION.
- Be sure to follow all the precautions below: they are all important for ensuring safety.
- ⚠ **WARNING:** Failure to follow any of **WARNING** is likely to result in grave consequences such as death or serious injury.
- ⚠ **CAUTION:** Failure to follow any of **CAUTION** may in some cases result in grave consequences.
- The following safety symbols are used throughout this manual:



Be sure to observe this instruction



Be sure to establish an earth connection



Never attempt

- After completing installation, test the unit to check for installation errors. Give the user adequate instructions concerning the use and cleaning of the unit according to the Operation Manual.

### ⚠ WARNING

- Installation should be left to the dealer or another professional. Improper installation may cause water leakage, electrical shock, or fire.
- Install the air conditioner according to the instructions given in this manual. Incomplete installation may cause water leakage, electrical shock, or fire.
- Be sure to use the supplied or specified installation parts. Use of other parts may cause the unit to come loose, water leakage, electrical shock, or fire.
- Install the air conditioner on a solid base that can support the unit's weight. An inadequate base or incomplete installation may cause injury in the event the unit falls off the base.
- Electrical work should be carried out in accordance with the installation manual and the national electrical wiring rules or code of practice. Insufficient capacity or incomplete electrical work may cause electrical shock or fire.
- Be sure to use a dedicated power circuit. Never use a power supply shared by another appliance.
- For wiring, use a cable long enough to cover the entire distance with no connection. Do not use an extension cord. Do not put other loads on the power supply, use a dedicated power circuit. (Failure to do so may cause abnormal heat, electric shock or fire.)
- Use the specified types of wires for electrical connections between the indoor and outdoor units. Firmly clamp the interconnecting wires so their receive no external stresses. Incomplete connections or clamping may cause terminal overheating or fire.
- After connecting interconnecting and supply wiring be sure to shape the cables so that they do not put undue force on the electrical covers or panels. Install covers over the wires. Incomplete cover installation may cause terminal overheating, electrical shock, or fire.
- If any refrigerant has leaked out during the installation work, ventilate the room. (The refrigerant produces a toxic gas if exposed to flames.)
- After all installation is complete, check to make sure that no refrigerant is leaking out. (The refrigerant produces a toxic gas if exposed to flames.)
- When installing or relocating the system, be sure to keep the refrigerant circuit free from substances other than the specified refrigerant(R410A), such as air. (Any presence of air or other foreign substance in the refrigerant circuit causes an abnormal pressure rise or rupture, resulting in injury.)
- During pump-down, stop the compressor before removing the refrigerant piping. If the compressor is still running and the stop valve is open during pump-down, air will be sucked in while the compressor is running, causing abnormal pressure and no condense-able added to the system.
- Be sure to establish a ground. Do not ground the unit to a utility pipe, arrester, or telephone earth. In complete earth may cause electrical shock, or fire. A high surge current from lightning or other sources may cause damage to the air conditioner.



### ⚠ CAUTION

- Do not install the air conditioner in a place where there is danger of exposure to inflammable gas leakage. If the gas leaks and builds up around the unit, it may catch fire.
- Establish drain piping according to the instructions of this manual. Inadequate piping may cause flooding.
- Tighten the flare nut according to the specified method such as with a torque wrench. If the flare nut is tightened too hard, the flare nut may crack after a long time and cause refrigerant leakage.
- Make sure to provide for adequate measures in order to prevent that the outdoor unit be used as a shelter by small animals. Small animals making contact with electrical parts can cause malfunctions, smoke or fire. Please instruct the customer to keep the area around the unit clean.



## Introduction to System

Single Zone Ductless Split System Heat Pumps feature a wall mounted indoor fan/evaporator unit that receives refrigerant from an inverter driven variable speed outdoor condensing unit. The system operation is controlled with a remote control.

The outdoor unit features a variable speed rotary compressor, EEV metering device and DC fan motor. These systems use R410A refrigerant and PVE oil. The outdoor units are 208/230 volt rated systems. They come factory charged for up to 25 ft. of interconnecting piping.

The indoor units are wall mounted type. They feature a DC blower motor and a DC louver motor. The unit has a room temperature sensor and an evaporator tube temperature sensor. The wall unit is powered by voltage from the outdoor unit.

## Specifications for proper operation should be followed

- The systems are designed to operate in temperature ranges of 60°F to 86°F in cooling mode and 60°F to 86°F in heat mode.
- PVE oil is non reactive to water and will not go into Hydrolysis. There is no need to add a refrigeration drier when servicing or installing this system.
- The indoor wall mounted unit receives operating voltage and communication data signals on #14 AWG wire that connects between the indoor and outdoor units. There should not be any splices in the field wiring that goes between terminals 1, 2, 3 and 4. A splice in these wires may cause the system to lose communication between the indoor and outdoor units. The system will then display an error code E7.
- The systems come with enough factory charge for up to 25 feet of connecting refrigeration tubing. The tubing connects using flare type fittings at both the indoor and outdoor units. Tubing must be sized per the specifications. Both lines must be insulated. The only method of checking charge or adjusting charge is by weight method explained in this manual. (No exceptions.)
- The condensate system is a gravity type. A field installed condensate pump may be added to the system. Always follow the manufacturer's installation instructions when installing a condensate pump.
- Proper clearances at both indoor and outdoor units must be maintained. Improper clearances cause system conditions that include high refrigerant pressure, low refrigerant pressure and indoor coil freezing problems.

## Fundamental Theory Of How System Works

The indoor unit will sense room temperature at the point where the wall unit is installed. The indoor fan will run continuously when placed in heating or cooling mode operation and will not cycle on and off with the outdoor unit. If it did, room temperature could not be sensed or

maintained.

The inverter compressor system in the outdoor unit will vary the refrigerant flow and indoor air volume levels to match the cooling requirement inside the conditioned space. If an abnormal condition is detected by the system's sensors, the system has the ability to take reactive measures.

The amount of refrigerant flow and associated capacity generated by the system will be determined by how fast the system's variable speed rotary compressor is pumping. The compressor operating speed requirement is determined by the difference between the conditioned space temperature versus the set point established by the homeowner's remote control.

If a large amount of capacity is needed, the compressor will operate at a high frequency speed. As the need for capacity reduces and the temperature of the room nears set point, the compressor will slow down. When set point has been reached, the compressor will shut off but the indoor fan will continue to operate. Once a difference in temperature is sensed between remote control set point temperature and room temperature, the compressor will restart at a new calculated speed.

If a system sensor determines there is a need to adjust the frequency signal to prevent a system malfunction, the compressor frequency may be over ridden and a new frequency established. It should be noted that the frequency signal level that is sent to the compressor cannot be determined by a servicing technician.

In this manual, system components, operation, sensor functions and diagnostic procedures will be explained in greater detail.



Table of Contents

Outdoor Unit Introduction ..... 8  
Outdoor Component Identification ..... 8  
Outdoor Main Control Board ..... 9  
Terminal Block..... 10  
Reactor ..... 10  
Compressor ..... 10  
Outdoor Fan Motor ..... 10  
Discharge Temperature Sensor ..... 11  
Defrost Temperature Sensor ..... 11  
Outdoor Ambient Temperature Sensor ..... 11  
Suction Line Temperature Sensor..... 11  
4-Way Valve ..... 12  
Electronic Expansion Valve..... 12  
Accumulator ..... 12  
Filters..... 12

## Outdoor Unit Introduction

The outdoor condensing unit models are heat pump systems. The outdoor unit has two circuit boards, a Module board that drives the compressor and a Main Control Board that manages system functions and inverter calculations. Temperature sensors monitor key temperatures throughout the system to manage operational decisions.

## Outdoor Component Identification

- 1 4-Way Valve
- 2 Accumulator
- 3 Compressor
- 4 Defrost Temperature Sensor
- 5 Discharge Temperature Sensor
- 6 Electronic Expansion Valve
- 7 Refrigerant Filters
- 8 Outdoor Ambient Temperature Sensor
- 9 Outdoor Fan Motor
- 10 Power Factor Reactor
- 11 Suction Line Temperature Sensor
- 12 Terminal Block
- 13 Main Control Board
- 14 Module Control Board
- 15 Fan Blade

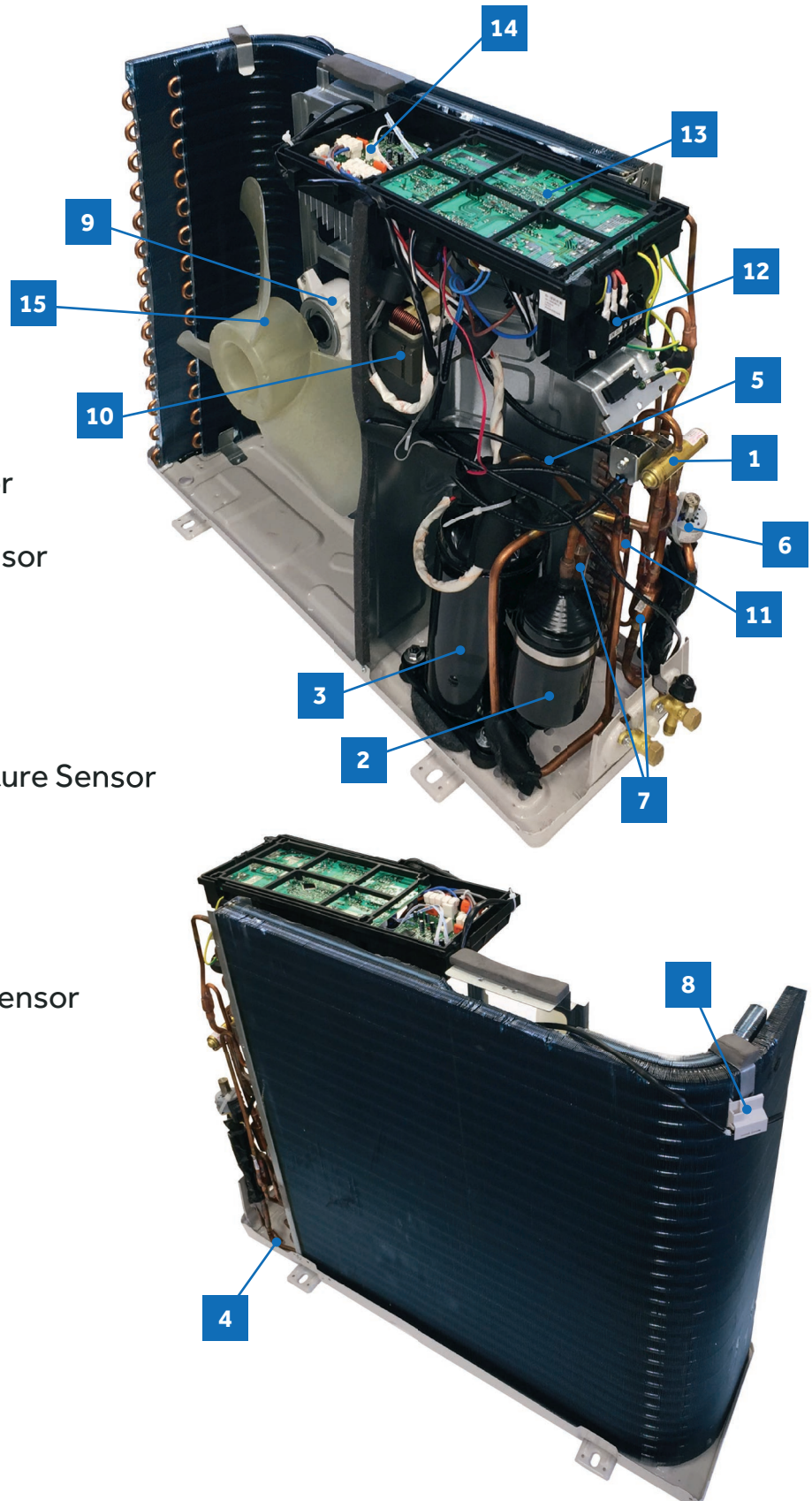



# Outdoor Control Board

## PCB (1) (Outdoor Control PCB)

- 1** CN1, CN2 - Connector for power N and L
- 2** CN3 - Connector for ground
- 3** CN23 - Connector for DC POWER 15V and 5V to the module board
- 4** CN9, CN10 - Connector for CN2, CN1 on the module board
- 5** CN22 - Connector for fan motor
- 6** CN11 - Connector for four way valve coil
- 7** CN17, CN47 - Connector for thermistors
- 8** CN24 - Communication connector for control board and the module board
- 9** CN26, CN25 - Connector to P and N of the module board
- 10** CN36 - Connector for communicate between indoor and outdoor unit
- 11** CN15 - Connector for electric expansion valves
- 12** CN50 - Connector for DRED-control
- 13** FUSE 1, (25A, 250VAC); FUSE 2(1A, 250VAC)
- 14** LED 1 Keep light representative normal, if keep flash interval representative trouble Alarm
- 15** RV1, RV2, RV3 Varistor

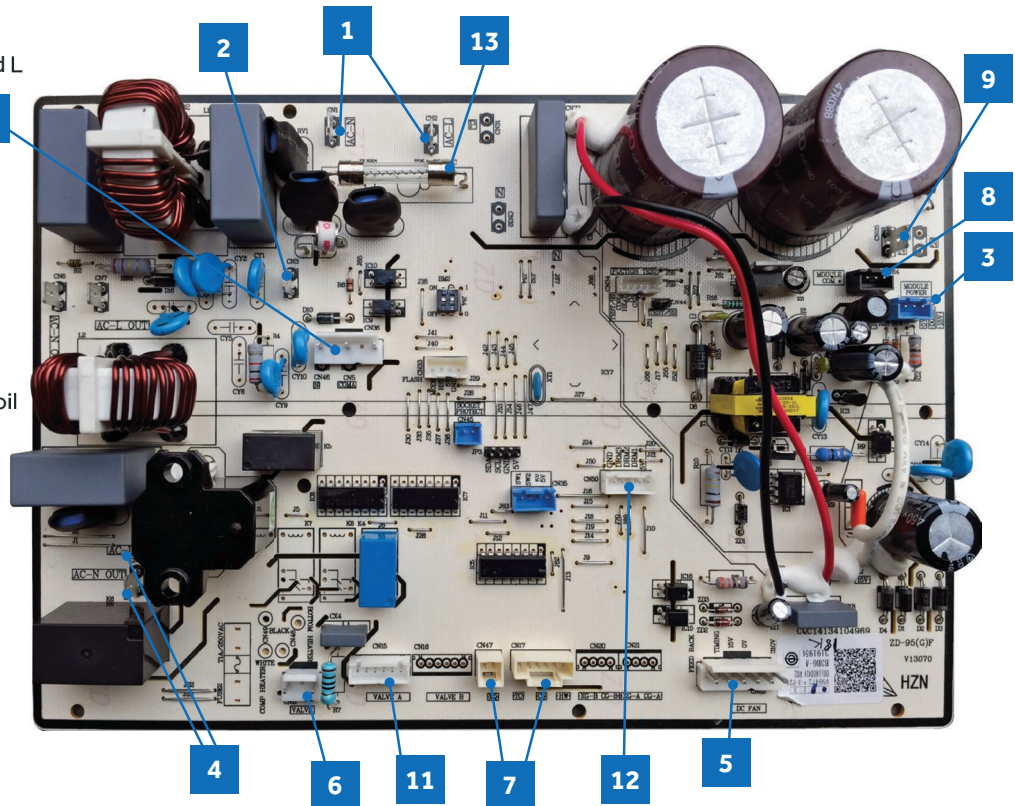

## PCB (2) (Module PCB for 09-12K )

- 16** CN10 - Connector for the DC power 5V and 15V form the control PCB
- 17** CN11 - Connector for communicate between the control board and the module board
- 18** P (CN1), N (CN5) - Connector for capacitance board
- 19** LI (CN7), LO (CN6) - Connector for reactor
- 20** CN2, CN3, CN4 - Connector for the U, V, W wire of the compressor

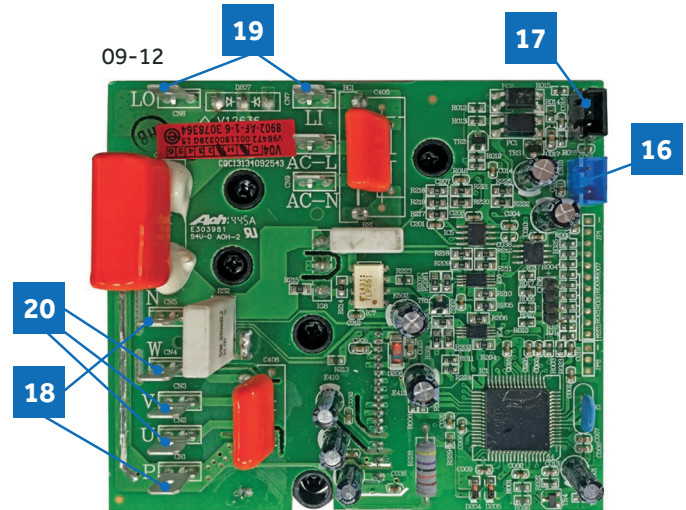

## PCB (3) (Module PCB for 18-24K )

- 21** CN10 - Connector for the DC power 5V and 15V form the control PCB
- 22** CN11 - Connector for communicate between the control board and the module board
- 23** P (CN8), N (CN9) - Connector for capacitance board
- 24** LI (CN3), LO (CN4) - Connector for reactor
- 25** CN5, CN6, CN7 - Connector for the U, V, W wire of the compressor

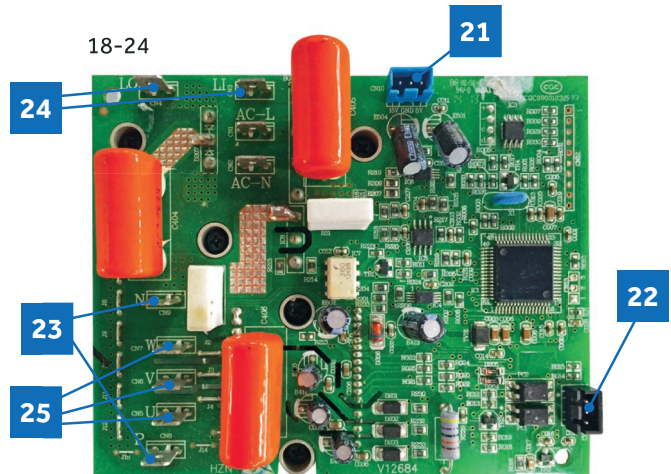

## Terminal Block

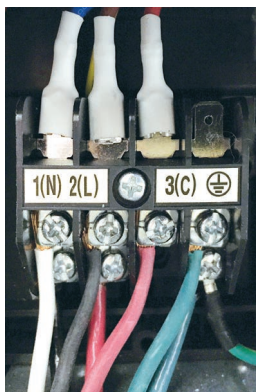

The outdoor unit is powered by 208/230 Volt Single Phase electricity connected at the Outdoor Unit Terminal Block. Terminals 1 and 2 on the outdoor unit terminal connect this voltage to the system. The number 3 terminal is a communication terminal that connects wiring between the indoor and outdoor units. A ground terminal connects the outdoor unit to the line voltage power source.

Condensate safety switches should break wire 1.

The indoor unit is also powered by the same electrical supply as the outdoor unit. #14 AWG wire is connected to the wiring terminal block at the outdoor unit and is run to the indoor unit wire terminal block.

When installing the field supplied wiring, make certain the wire gauge is correct. There should not be any electrical wiring splices between the indoor unit and outdoor unit wire connection 3. This wire is used to carry communication data between the indoor and outdoor units. A wiring splice where wires are twisted in a wire nut may cause deformation of the communication of the data signal. If communication is lost between the indoor and outdoor units, an ERROR CODE E7 will occur. (See Page 48.)

## Power Factor Reactor

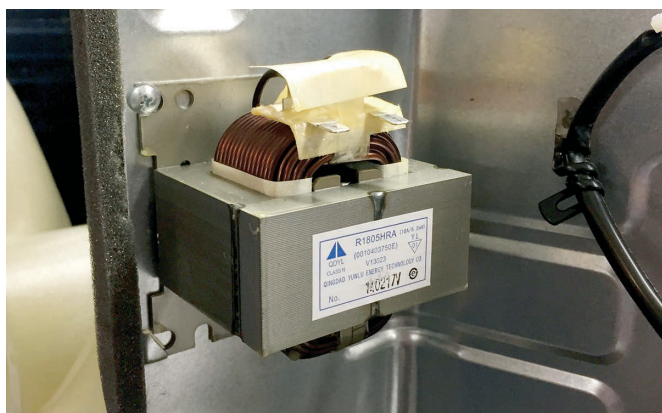

The Reactor is an inductive filter that will aid in correction of electrical power factor influence of inverter capacitance. It is unlikely to ever have an electrical failure of this component.

The Reactor is electrically connected to the Module Board on terminal connections CN-7 and CN-8.

## Compressor



The compressor is a three phase DC inverter driven Rotary type. The compressor is capable of variable speed operation. The compressor operating frequency will be determined by the temperature difference between set point and room or outdoor air temperature. (Cool Mode versus Heat Mode)

The compressor is electrically connected to the Module Board on terminal connections CN-2, CN-3 and CN-4.

The compressor has an internal temperature overload that will open if the compressor becomes too hot. Additional protection of the compressor will be provided by the Compressor Discharge Temperature Sensor and Suction Line Temperature Sensor.

## Outdoor Fan Motor



The outdoor fan motor is a variable speed motor. The required motor speed is calculated by the Main Control Board. The motor is electrically connected to the Main Control Board via PLUG CN-21.

In COOL MODE operation, the motor will slow down as outdoor air temperature falls. In HEAT MODE operation, the motor will increase speed as the outdoor air temperature falls.

## Discharge Temperature Sensor



The Discharge Temperature Sensor is a Negative Coefficient thermistor that senses the temperature of the compressor hot gas. The Main Control Board monitors the temperature of the compressor hot gas and will make inverter speed changes in response to input from this device.

This sensor connects to the Main Control Board at PLUG CN-17.

## Defrost Temperature Sensor

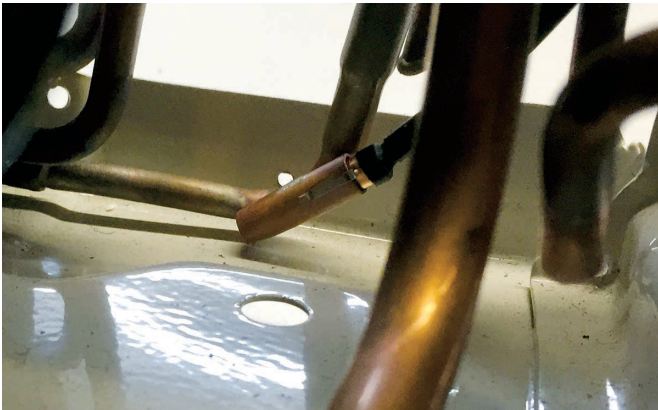

The Defrost Temperature Sensor is a negative coefficient thermistor that will change resistance in response to outdoor coil temperature changes. The Main Control Board monitors the temperature of the outdoor coil to determine when the system is needing to perform a defrost cycle. The sensor also monitors outdoor coil temperature during defrost cycles to determine termination conditions.

This sensor connects to the Main Control Board at PLUG CN-19.

## Outdoor Ambient Temperature Sensor

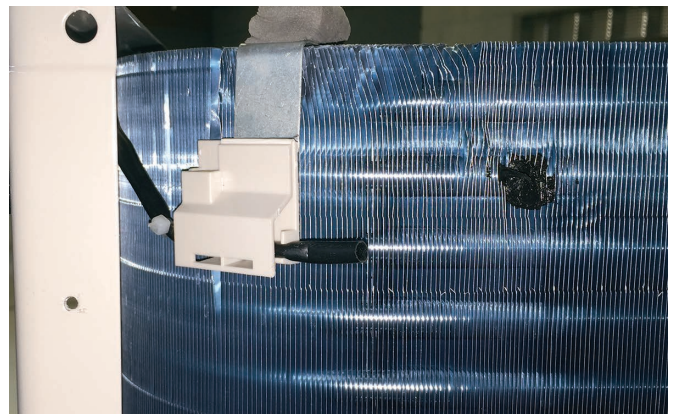

The Outdoor Ambient Temperature Sensor is a negative coefficient thermistor that will change resistance in response to outdoor air temperature changes. The Main Control Board monitors the temperature of the outdoor air to determine outdoor fan speed requirements and inverter speed. The sensor also plays a role in calculation of required defrost conditions.

This sensor connects to the Main Control Board at PLUG CN-20.

## Suction Line Temperature Sensor

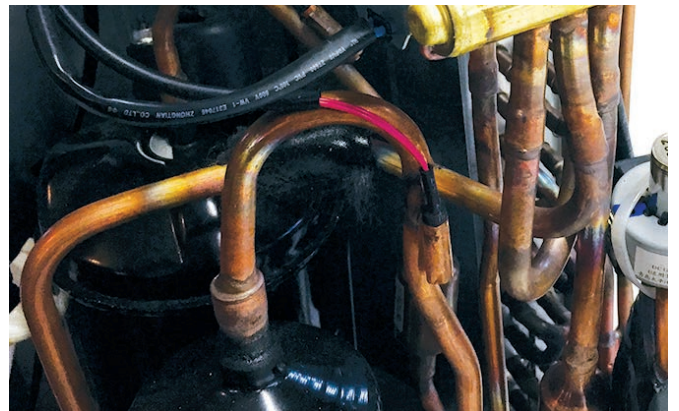

The Suction Line Temperature Sensor is a negative coefficient thermistor that senses the temperature of the suction line. The Main Control Board monitors the temperature of the suction line to determine EEV orifice size in an attempt to maintain proper operating superheat.

This sensor connects to the Main Control Board at PLUG CN-18.

## 4-Way Valve



The 4-Way Valve redirects the flow of refrigerant in the piping circuit to allow the system to swap the functions of the indoor and outdoor coils. When de-energized in COOL MODE, the valve will direct the refrigerant hot gas to the outdoor coil. When energized in HEAT MODE, the valve will direct the hot gas to the indoor coil.

The valve flow direction capability is controlled by an electrical solenoid. When energized by 240 Volts, line voltage, the solenoid will magnetically move an internal slide within the 4-Way Valve to change the direction of refrigerant flow.

The 4-Way Valve is electrically connected to the Main Control Board at PLUG CN-10.

## Electronic Expansion Valve



The metering device is an electronic expansion valve type EEV. The valve consists of an electrical operator and a valve body with internal variable size orifice. When operating, the Main Control Board will send pulses of voltage to the electrical operator. The operator will then magnetically move the position of the metering orifice pin to vary its size.

The metering device position is determined by input from a Suction Line Temperature Sensor located in the outdoor unit. The EEV will change the internal orifice size to maintain a superheat level of around 10°F.

During COOL MODE operation, the valve meters low pressure refrigerant to the indoor coil. During HEAT MODE operation, the valve meters low pressure refrigerant to the outdoor coil.

## Accumulator



The Accumulator is located in the suction line circuit at the entrance to the compressor. The accumulator helps prevent liquid refrigerant from entering the compressor during run operation.

## Refrigerant Filters



The system has debris catching filters that protect internal system components from contaminants in the refrigerant. The filter is a permanent part that is not typically replaced.

Table of Contents

Indoor Unit Introduction ..... 14

Indoor Component Identification ..... 14

Indoor Control Board..... 15

Terminal Block..... 16

Display..... 16

Ambient Temperature Sensor ..... 16

Piping Temperature Sensor ..... 16

Louver Motor ..... 17

Fan Motor ..... 17

Emergency Button ..... 17

DIP Switch and DIP Switch Settings..... 18

## Indoor Unit Introduction

The indoor unit is mounted high on the wall to provide air conditioning coverage of a conditioned space. Field installed/supplied condensate pump accessories can be added to these systems.

Features of the system include: Variable speed blower operation that speeds up and slows down with changes in demand, Moving louvers to direct air, Indoor air temperature sensing, Evaporator coil temperature sensing, Consumer operation display, Evaporator coil with metering device located in outdoor unit, and an Emergency Operation Switch.

## Indoor Component Identification

- |   |                                   |   |                           |
|---|-----------------------------------|---|---------------------------|
| 1 | Indoor Ambient Temperature Sensor | 5 | Main Control Board        |
| 2 | Display                           | 6 | Piping Temperature Sensor |
| 3 | Fan Motor                         | 7 | Power Supply Board        |
| 4 | Louver Motor                      | 8 | Terminal Block            |

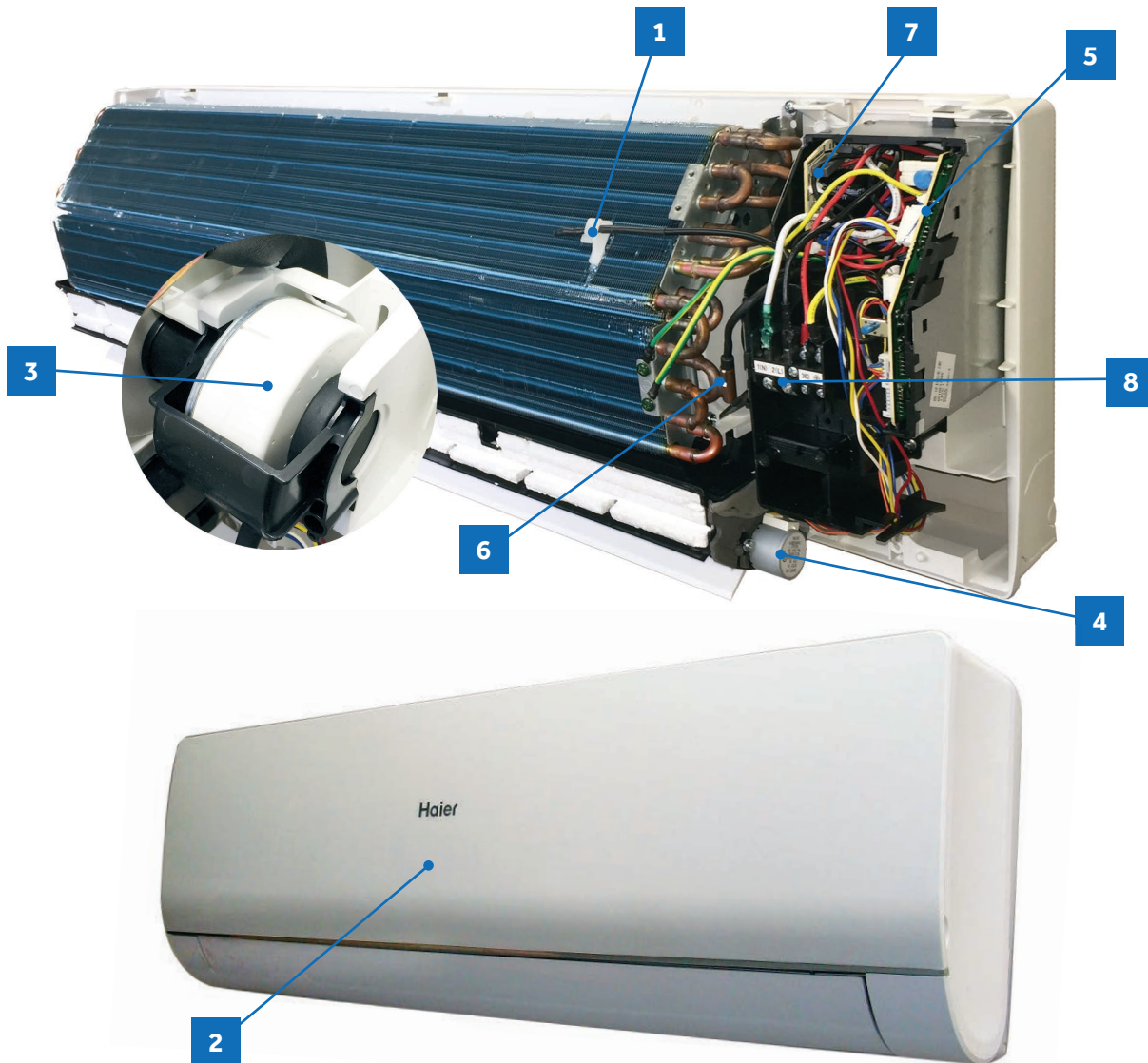

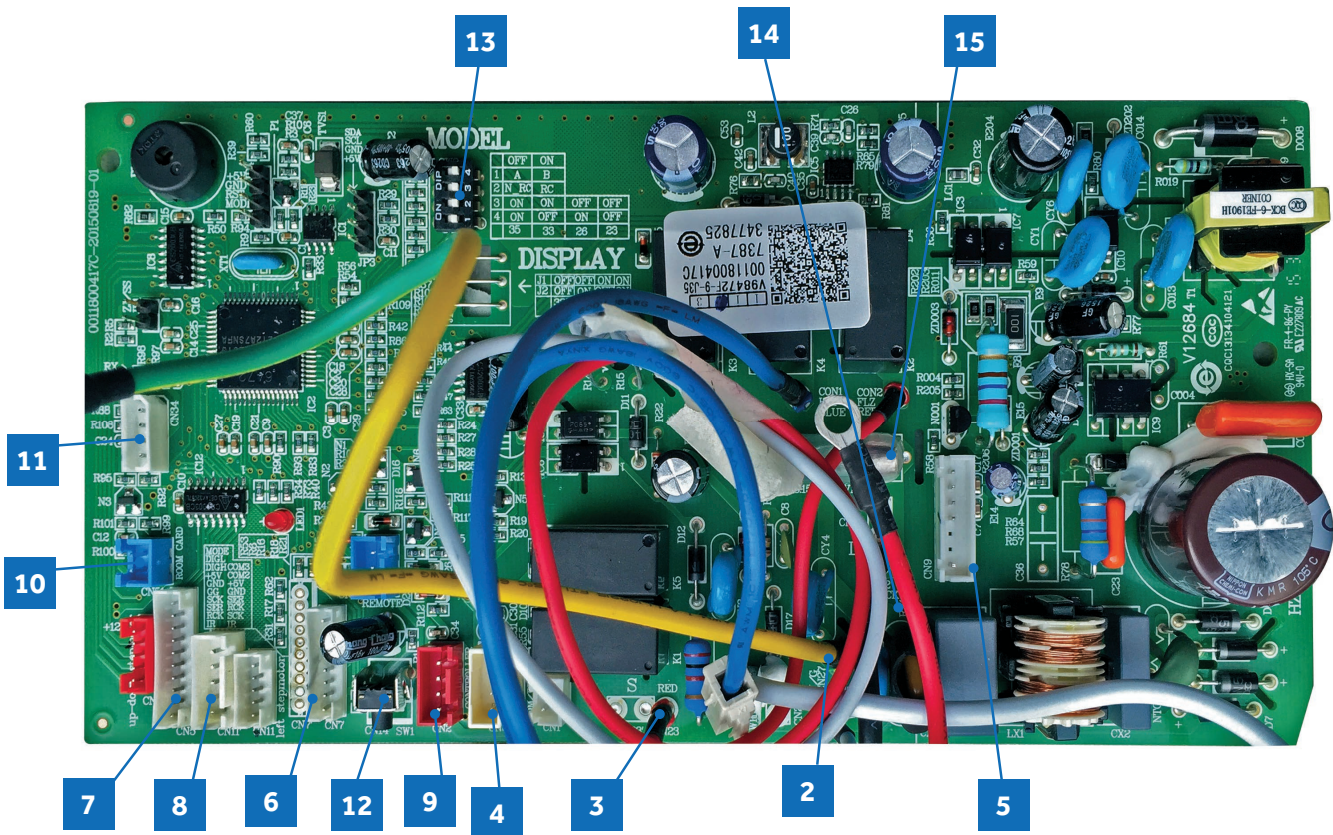

- |          |  |           |  |
|----------|--|-----------|--|
| <b>1</b> | CN21, CN52 - Connector for power N and L                           | <b>10</b> | CN51 - Connector for room card   |
| <b>2</b> | CN27 - Connector for ground  | <b>11</b> | CN34 - Connector for Wi-Fi-control   |
| <b>3</b> | CN23 - Connector for communication between indoor and outdoor unit | <b>12</b> | SW1 - Connector for Emergency operation ON / OFF switch  |
| <b>4</b> | CN6 - Connector for thermistors                                    | <b>13</b> | SW2 - 1-Select remote code A or B,<br>2-Select room card able or disable<br>3,4-Select eeprom code 23, 26, 33 and 35 |
| <b>5</b> | CN9 - Connector for fan motor                                      | <b>14</b> | RV1 - Varistor   |
| <b>6</b> | CN7 - Connector for display  | <b>15</b> | FUSE1 - Fuse 3.15A/250VAC  |
| <b>7</b> | CN5 - Connector for up-down stepper motor                          |           |  |
| <b>8</b> | CN11 - Connector for left-right stepper motor                      |           |  |
| <b>9</b> | CN2 - Connector for wiring-control                                 |           |  |

## Terminal Block

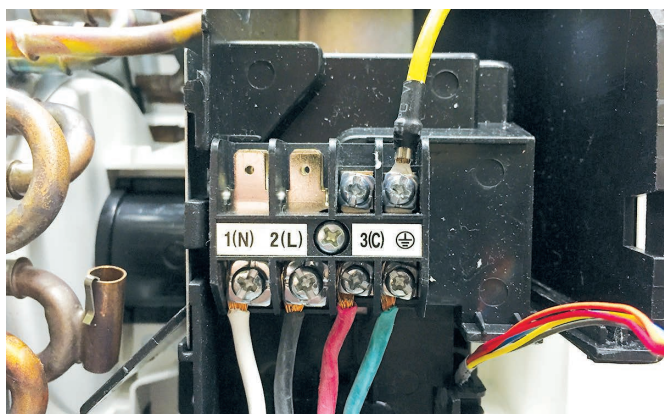

The indoor unit terminal block receives electrical power from the outdoor unit. There are 4 connections for electrical wires. Terminals 1 and 2 are connected to terminals 1 and 2 of the outdoor unit. This wiring supplies power to the indoor unit.

Terminal 3 is a communication wire. The indoor unit sends indoor air temperature, coil temperature and temperature setpoint information to the outdoor unit on this wire. If a splice or break in this wire is present, the indoor unit will not be able to communicate with the outdoor unit. The ERROR CODE will be code E7.

## Display



The indoor display has an infrared communication circuit that receives operating commands from the remote control. This display will indicate operating modes, error codes, indoor air temperature, timer status and power status.

## Ambient Temperature Sensor

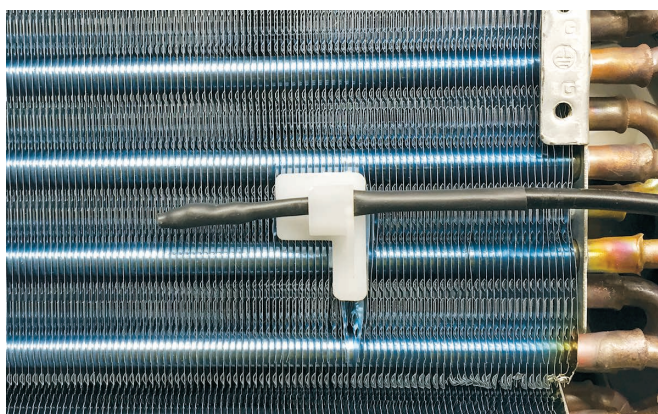

The Room Ambient Temperature Sensor is a negative coefficient thermistor that will decrease in resistance with increases in room air temperature. The sensor is located on a clip mounted to the surface of the indoor coil.

The sensor connects to the control board at Plug CN-6.

## Piping Temperature Sensor

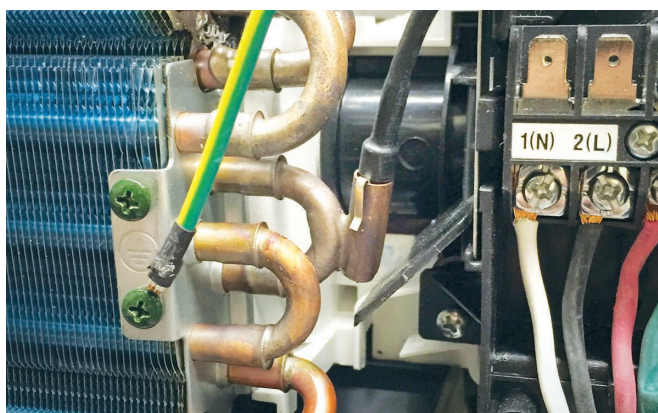

The Piping Temperature Sensor is a negative coefficient thermistor that will decrease in resistance with increases in coil temperature. The sensor is located in a socket soldered to the surface of the indoor coil.

This sensor will monitor the temperature of the indoor coil in both cooling and heating modes of operation. Should abnormally cold or hot coil temperature be detected by this sensor, the system will take functional corrective steps to correct the condition or report an ERROR CODE.

The sensor connects to the control board at Plug CN-6.



## Stepper Motor Louver

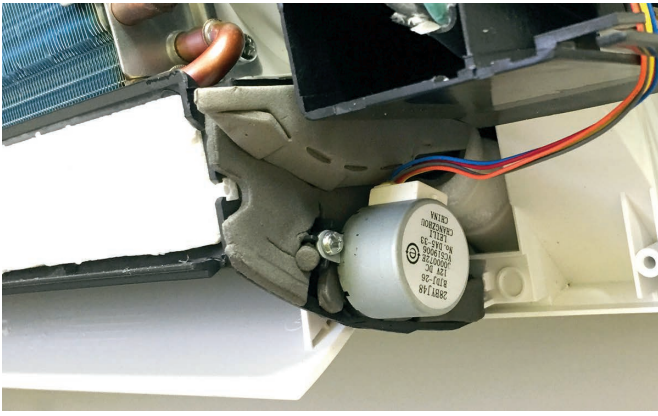

The STEPPER MOTOR moves the louver up or down, and right or left depending upon selections made at the remote control.

The motor is connected to the indoor control board at PLUG CN-11.

## Fan Motor

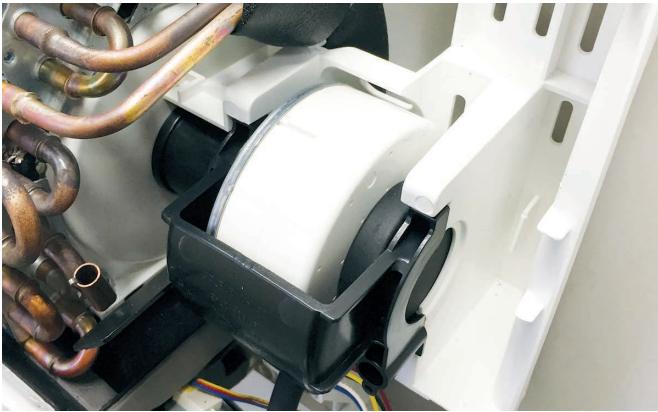

The Indoor Fan Motor is a variable speed motor. The motor will vary speed with the speed of the compressor inverter. The speed can also be set at the remote control or automatically adjusted using the AUTO fan mode. When in AUTO fan mode, the speed of the fan is calculated using the indoor set temperature and the indoor room ambient temperature. (Outdoor air temperature in heat mode.)

The Fan Motor is connected to the indoor control board via PLUG CN-9.

## Emergency Button

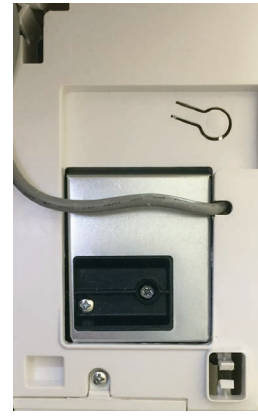

If the remote control is non-functional, the Emergency Button can be accessed by swinging open the front of the wall unit. The button is located on the right side.

Pushing this button will activate AUTO MODE operation. AUTO MODE activated with this button will maintain 75°F. The system will stay in this mode until commands are received by the indoor unit communication circuit via the remote control.

## DIP Switch

### DIP Switch Settings

The PCB for the indoor unit of the Advanced series of single zone mini-splits has a set of DIP switches that must be set when replacing the PCB.

The replacement PCB is shipped with all switches set to the OFF position.

Switch settings:

SW2-1 Selects remote code A or B. Normally set to the off position for code A operation.

If two indoor units are used in the same area and the user wishes to control them separately, switch SW2-1 of the second unit is set to the ON position for code B operation. The wireless remote for the second unit is also set to code B.

SW2-2 Selects room card able or disable.

Normally set to the OFF position. Set to the ON position when used in conjunction with a room card interface utilized in hotel rooms.

SW-3 & SW-4 Selects eeprom code 23, 26, 33 and 35. Set to identify the tonnage of the unit.

Settings:

9K	(23)	SW-3	OFF	SW-4	OFF
12K	(26)	SW-3	OFF	SW-4	ON
18K	(33)	SW-3	ON	SW-4	OFF
24K	(35)	SW-3	ON	SW-4	ON

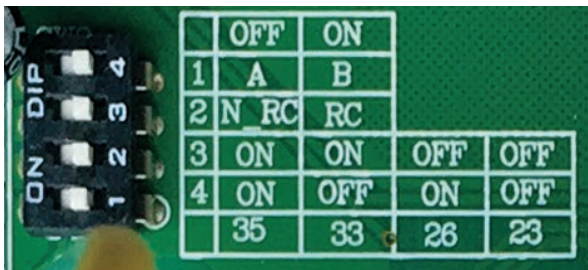
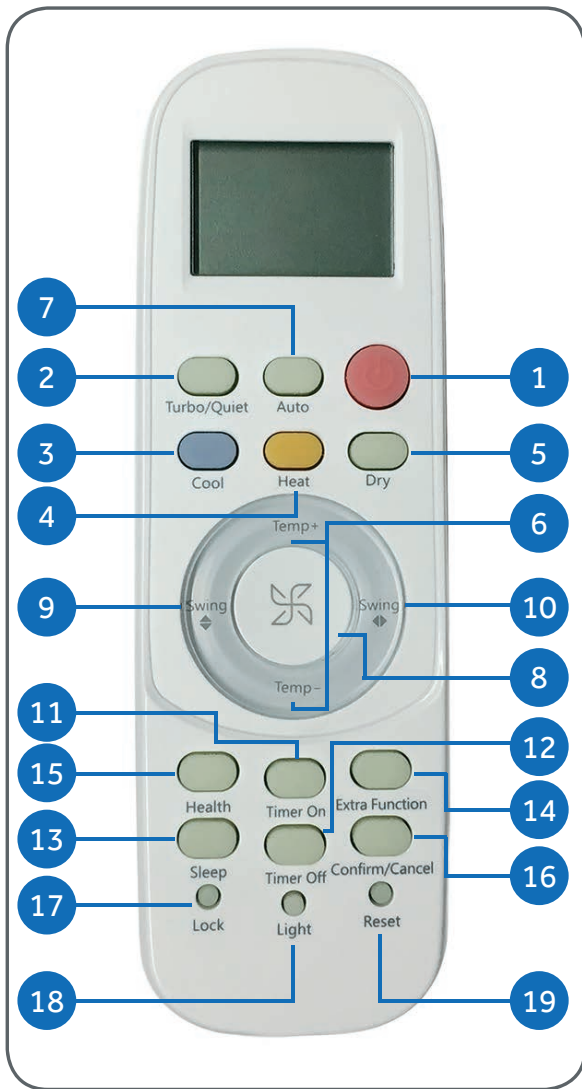

Table of Contents



Remote Controller ..... 20





### 1 Power Button

Press the ON/OFF  button on the remote control to start the unit.

### 2 TURBO/QUIET Button

The TURBO function is used for fast heating or cooling. Press the TURBO/QUIET  button once and the remote control will display the TURBO  icon on the bottom right side of the remote display and switch the unit to the TURBO function.

The QUIET function may be used when silence is needed for fast rest or reading. Press the TURBO/QUIET  button again to switch to QUIET mode and the remote control will display the QUIET  icon on the bottom left side of the remote display.

Press the TURBO/QUIET  button a third time to cancel TURBO/QUIET and return to normal operation.

Note:  
TURBO/QUIET modes are only available when the unit is under cooling or heating mode (not for auto or fan mode).

Running the unit in QUIET mode for a long period of time may cause the room temperature to not reach the set temperature. If this occurs, cancel QUIET mode and set the fan speed to a higher setting.

### 3 COOL Button

In COOL mode, the unit operates in cooling. When FAN is set to AUTO, the air conditioner automatically adjusts the fan speed according to room temperature. The  will be displayed during COOL mode.

### 4 HEAT Button

In HEAT mode, warm air will blow out after a short period of the time due to cold-air prevention function. When FAN is set to AUTO, the air conditioner automatically adjusts the fan speed according to room temperature. The  will be displayed during HEAT mode.

### 5 DRY Button

DRY mode is used to reduce humidity. In DRY mode, when room temperature becomes lower than temp. setting +2°F, unit will run intermittently at LOW speed regardless of FAN setting. The  will be displayed during DRY mode.

### 6 Temperature +/- Buttons

Temp + Every time the button is pressed, the temperature setting increases.

Temp - Every time the button is pressed, temperature setting decreases.

The operating temperature range is 60°F-86°F (16°C-30°C).

### 7 AUTO Button

Under the mode of auto operation, the air conditioner will automatically select Cool, Heat, or Fan operation according to set temperature. When FAN is set to AUTO the air conditioner automatically adjusts the fan speed according to room temperature. The  will be displayed during AUTO mode.

### 8 FAN Button

Fan speed selection

Press the FAN  button. For each press, fan speed changes as follows:

Remote control:

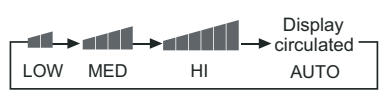

The air conditioner fan will run according to the displayed fan speed.

When FAN is set to AUTO, the air conditioner automatically adjusts the fan speed according to room temperature.

## 9 Louver SWING Button - Vertical

### Air Flow Direction Adjustment

Press the SWING UP/DOWN button to choose the position of the vertical airflow louvers.

Status display of air flow

COOL/DRY:



HEAT:



Caution:

- It is advisable not to keep the vertical louver in the downward position for an extended period of time in COOL or DRY mode, otherwise condensate water may form on the louver.

Note:

When turning the unit on, the remote control will automatically return the louver to the previous set swing position. When turning the unit off, the louver will rotate to the full open position prior to closing.

## 10 Louver SWING Button - Horizontal

Press the SWING UP/DOWN button to choose the position of the horizontal airflow louvers.

Status display of air flow

COOL/DRY/HEAT:

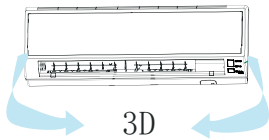
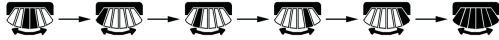

Caution:

- When humidity levels are high, condensate water may occur at the air outlet if all horizontal louvers are adjusted to left or right.

Note:

When turning the unit on, the remote control will automatically return the louver to the previous set swing position. When turning the unit off, the louver will rotate to the full open position prior to closing.

## 11 Timer ON Button

On-Off Operation

- Start the unit and select the desired operating mode.
- Press the TIMER ON button to enter the TIMER ON mode. The remote control will start flashing "ON".
- Every time the TIMER ON button is pressed the length of time increases in 0.5 hour increments between hours 0 and 12, and 1 hour increments for times between hours 12 and 24.
- Once the desired length of time is selected for the unit to turn on, press the CONFIRM/CANCEL button to confirm this setting.

The remote control display changes as follows:

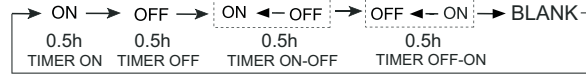

Cancel TIMER ON setting:

With a TIMER ON set, press the CONFIRM/CANCEL button once to cancel the TIMER ON.

Turning the unit ON with the TIMER from it being OFF will look like this on the remote control display:



Note:

Holding the TIMER ON button down will rapidly cycle the time. After replacing batteries or a power failure occurs, the time setting will need to be reset.

According to the Time setting sequence of TIMER ON or TIMER OFF, either Start-Stop or Stop-Start can be achieved.

## 12 Timer OFF Button

On-Off Operation

- Start the unit and select the desired operating mode.
- Press the TIMER OFF button to enter the TIMER OFF mode. The remote control will start flashing "OFF".
- Every time the TIMER OFF button is pressed the length of time decreases in 0.5 hour increments between hours 0 and 12, and 1 hour increments for times between hours 12 and 24.
- Once the desired length of time is selected for the unit to turn off, press the CONFIRM/CANCEL button to confirm this setting.

The remote control display changes as follows:

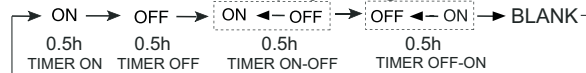

Cancel TIMER OFF setting:

With a TIMER OFF set, press the CONFIRM/CANCEL button once to cancel the TIMER OFF.

Turning the unit OFF with the TIMER from it being ON will look like this on the remote control display:



Note:





Holding the TIMER OFF button down will rapidly cycle

the time. After replacing batteries or a power failure occurs, the time setting will need to be reset.

According to the Time setting sequence of TIMER ON or TIMER OFF, either Start-Stop or Stop-Start can be achieved.

### 13 SLEEP Button

#### Sleep mode

Press the Extra Function  button to enter additional options, cycle the button to display the , the  icon will flash. Press the Confirm/Cancel  button to enter the sleep function.

#### Sleep Operation Mode

##### 1. SLEEP mode during COOL, DRY modes

One hour after SLEEP mode starts, the temperature will rise 2°F above set temperature, after another hour, the temperature rises an additional 2°F. The unit will run for an additional six hours, then turns off. The final temperature is 4°F higher than the initial set temperature. Using this feature will help with achieving maximum efficiency and comfort from your unit while you sleep.

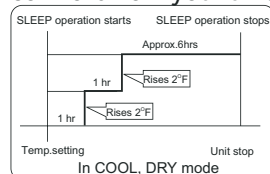

##### 2. SLEEP mode during HEAT mode

One hour after SLEEP mode starts, the temperature will decrease 4°F below set temperature, after another hour, the temperature will decrease an additional 4°F. After an additional three hours, the temperature will rise by 2°F. The unit will run for an additional three hours, then turns off. The final temperature is 6°F lower than the initial set temperature. Using this feature will help with achieving maximum efficiency and comfort from your unit while you sleep.

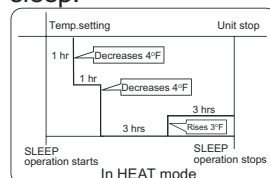

##### 3. In AUTO mode

The unit operates in corresponding sleep mode adapted to the automatically selected operation mode.

#### Note:

- When the unit is set to sleep mode, the fan speed will be set to low speed and cannot be changed.
- When the TIMER function is set, the sleeping function cannot be set. If the sleeping function has been set, and the user sets the TIMER function, the sleeping function will be canceled, and the unit will be set to the timer function.

### 14 EXTRA FUNCTION Button

Function:

**A) Refresh air** - Feature not available on this series.

**B) A-B Yard** - This will allow you to control two separate units with a single remote control.

Note: this feature would be setup at the time of installation by the contractor.

**C) Fan Mode** - Is indicated by the  icon. Only the fan will operate in this mode. See section 8 "FAN Button" for changing the fan settings.

**D) Intelligent upward airflow, E) Intelligent downward airflow, F) Reset intelligent airflow position**

1. Press the ON/OFF button on the remote control to turn the unit on.

Select the desired operating mode.



2. Setting the intelligent airflow function

Press the EXTRA FUNCTION  button to enter additional options. Press this button repeatedly to access the louver settings. The louver icon will cycle through the following three settings.





Select the desired position, then press the CONFIRM/CANCEL  button to set the function.

3. Canceling the intelligent airflow function



Press the EXTRA FUNCTION  button to enter additional options. Press this button repeatedly to access the louver settings. Cycle the button to the louver icon "present" position, then press the CONFIRM/CANCEL  button to cancel the function.

Notice: Do not reposition the horizontal louver by hand. This may cause the louver to run incorrectly and not match the icon displayed on the remote control. If the louver is not running correctly, turn the unit off for one minute, then back on, and adjust the louver setting with the remote control.

#### Note:

1. After setting the intelligent airflow function, the louver position is fixed.
2. In cooling, it is better to select the  mode.
3. In heating, it is better to select the  mode.
4. In cooling and dry modes, using the air conditioner for a long period of time under high humidity conditions, condensate water may form on the grille/louver.

**G) Fahrenheit/Celsius mode shift on unit and remote** -

To switch between Fahrenheit and Celsius press the EXTRA FUNCTION  button until either Celsius or Fahrenheit is displayed. Press the CONFIRM/CANCEL  button to apply the change.

**H) 50°F low temperature heating** - Feature not available on this series.

**I) Electrical heating** - Feature not available on this series.

**15 HEALTH Button**

---

Feature not available on this series.

**16 Confirm/Cancel Button**

---

Function: Setting and canceling timer and other functions.

**17 LOCK Button**

---

Used to lock buttons and LCD display

**18 LIGHT Button**

---

Turns indoor unit display on and off

**19 RESET Button**

---

If the remote control is not functioning properly, use a pen point or similar object to depress this button to reset the remote.





Table of Contents

**System Power ..... 26**

**Cool Mode ..... 26**

*Overview..... 26*

*Indoor Unit..... 26*

*Temperature sensors..... 26*

*Communication..... 26*

*Outdoor unit..... 26*

*Temperature sensors..... 27*

*Call to Terminate Cooling ..... 27*

*Freeze protection function ..... 27*

**Heat Mode..... 27**

*Overview..... 27*

*Cold air proof operation..... 27*

*Defrost..... 28*

*Automatic Heating Temperature Compensation ..... 28*

*Indoor Unit..... 28*

*Temperature sensors..... 28*

*Communication..... 28*

*Outdoor unit..... 28*

*Temperature sensors..... 28*

*Call to Terminate Heating ..... 29*

**Auto Mode..... 29**

**Dry Mode ..... 29**

*Overview..... 29*

*Indoor Unit..... 29*

*Temperature sensors..... 29*

*Communication..... 29*

*Outdoor unit..... 29*

*Temperature sensors..... 30*

**Defrost Operation..... 30**

**Protection Functions ..... 30**

*TTC high temperature protection..... 30*

*Overheating protection for indoor unit ..... 30*

*Compressor overcurrent protection ..... 31*

*Anti-freeze protection of the indoor heat exchanger..... 31*

## System Power

The 240 Volt AC power for the system connects to terminals 1(N), 2(L), and ground of the outdoor unit terminal block. This terminal block also has terminals to connect power to the indoor unit.

The voltage readings between terminals 1(N) and ground, and terminals 2(L) and ground should be 120 VAC. The voltage reading between terminals 1(N) and 2(L) should be 240 VAC.

One additional connection on the terminal block (3) is for the communication wire between the indoor and outdoor units.

NOTE: Mis-wiring of these connections may cause improper operation or damage to system components.

## Cool Mode

### Overview

The temperature control range in cooling mode is 60°F - 86°F. The temperature set by the remote control and the indoor unit ambient temperature sensor will determine if a call for cooling is needed. If a call for cooling is justified, the call is communicated from the indoor unit to the outdoor unit. The indoor unit louver will open using a stepper motor, and the indoor fan will operate at the speed last set. The outdoor unit will determine the position of the EEV and speed (frequency) of the compressor. There can be a delay of up to 3 minutes before the outdoor unit fan and compressor start.

The speed of the indoor fan can be controlled manually by the user or automatically by the system. The speed can be changed between LOW, MEDIUM, and HIGH. The predetermined conditions for automatic control are as follows:

(Tr= room temperature Ts= set temperature)

High Speed:  $Tr \leq Ts + 5.4^{\circ}\text{F}$

Medium Speed:  $Ts + 1.8^{\circ}\text{F} \leq Tr < Ts + 5.4^{\circ}\text{F}$

Low Speed:  $Tr \leq Ts + 1.8^{\circ}\text{F}$  or when the sensor is off.

There will be a 2 second delay when manually controlling the speed.

The outdoor unit temperature sensors: outdoor ambient, defrost, suction line, and compressor discharge, used in conjunction with the indoor temperature sensors, indoor ambient and tube, provide information to the outdoor control board to monitor the system and regulate the frequency of the compressor, EEV positioning, and outdoor fan speed to achieve the desired room temperature.

When cooling has been satisfied, the outdoor unit compressor will turn off, followed by the outdoor fan. The indoor unit fan will continue to run.

If the system detects a malfunction, it may shut down or show an error code on the indoor unit display board and/or outdoor unit main board LED.

## Indoor Unit

To enter the cool mode, point the infrared remote control at the indoor unit and press the power button, then press the COOL mode button if not already set to cool mode.

The signals received by the infrared receiver are relayed to the main board of the indoor unit to turn the system on and set it to cool mode.

The indoor unit main board will activate the display of the indoor unit, illuminating the display, indicating the room temperature and current status of the unit.

The indoor unit main board will signal the louver stepper motor to open the louver to either a stationary position, or one of several oscillating modes.

As the louver opens, the indoor unit main board will power up the indoor fan motor, operating the fan at the speed last set. The indoor fan motor has a feedback circuit which provides the indoor unit main board with information for controlling the speed of the fan motor.

### Temperature sensors

The indoor unit has two sensors that provide temperature information to the indoor unit main board. The sensors: an indoor ambient temperature sensor, and pipe temperature sensor, are used for controlling the system during cool mode. The resistance values of the sensors will vary with temperature. The resistance to temperature values can be found using a temperature / resistance chart specific to the sensor being checked.

### Communication

The indoor and outdoor unit main boards communicate via a digital signal on the wire connected to terminal 3 of each unit. A splice or break in this wire will cause a communication error.

When a command is received from the remote control, the indoor unit main board communicates with the outdoor unit main board via the terminal 3 wire to perform the requested function.

### Outdoor unit

Upon a request for cooling, the outdoor unit main board applies power to the outdoor fan motor and compressor. Depending on system cycling, there may be up to a 3 minute wait period before the compressor and outdoor fan start.

**WARNING:** Do not measure compressor voltages, damage to the meter may result.

If the ambient room temperature is less than the set temperature, yet higher than 2°F below the set temperature, the system will adjust the running frequency of the compressor automatically according to changes in ambient temperature.

The outdoor unit main board also controls the position of the EEV (Electronic Expansion Valve) to regulate the flow of refrigerant to the indoor unit evaporator coil.

## Temperature sensors

Four temperature sensors located in the outdoor unit provide temperature information to the outdoor unit main board for control of the system during cool mode.

The outdoor ambient temperature sensor provides the temperature of the air drawn into the condenser coil of the outdoor unit.

The defrost temperature sensor provides the temperature sensed at the output of the condenser coil.

The suction line temperature sensor provides the temperature sensed at the incoming suction line pipe.

The compressor discharge sensor provides the temperature sensed at the discharge pipe of the compressor.

## Call to Terminate Cooling

The system will call to terminate cooling when the indoor ambient temperature sensor is equal to or lower than 2°F of the room set temperature. The indoor control board will communicate to the outdoor control board to de-energize the compressor. The outdoor fan will run for 60 seconds before stopping.

The indoor fan motor and louver will continue operating after cooling has been terminated.

To stop cool mode, press the power button to turn the system off, or change to another mode.

## Freeze protection function

To prevent freezing of the indoor unit coil during cool mode, when the compressor operates continuously for 10 seconds and the temperature of the indoor coil has been below 32°F for 10 seconds, the compressor will stop, and the error will be recorded in the malfunction list. The indoor unit fan will continue to operate. When the temperature of the indoor coil rises to 45°F for more than 3 minutes the compressor will restart and the system will continue functioning.

## Heat Mode

### Overview

The temperature control range in heating mode is 60°F - 86°F. The temperature set by the remote control and the indoor unit ambient temperature sensor will determine if a call for heat is needed. If a call for heat is justified, a temperature compensation adjustment is automatically added to the

operating parameter and the call is communicated from the indoor unit to the outdoor unit.

The indoor unit louver will open using a stepper motor. The indoor fan will not operate at this time.

The outdoor unit will shift the 4-way valve to the heat mode position and determine the position of the EEV (if equipped) and speed (frequency) of the compressor. There can be a delay of up to 3 minutes before the outdoor unit fan and compressor start.

(Tr = room temperature Ts = set temperature)

If  $Tr \leq Ts$ , the outdoor unit will operate and the indoor fan operates in cold air prevention function

If  $Tr > Ts + 4$ , the outdoor unit turns off and the indoor fan operates at heat residue sending mode.

If  $Tr < Ts + 4$ , the outdoor unit will restart and the indoor fan operates in cold air proof mode.

The speed of the indoor fan can be controlled manually by the user or automatically by the system. The speed can be changed between HIGH, MEDIUM, and LOW. The predetermined conditions for automatic control are as follows:

High Speed:  $Tr < Ts$

Medium Speed:  $Ts \leq Tr \leq Ts + 4^\circ F$

Low Speed:  $Tr > Ts + 4^\circ F$

When the indoor fan is running in automatic mode and there is no delay when the speed switches from high to low, the indoor fan will maintain high speed for a period of 3 minutes before switching to low speed.

## Cold air proof operation

At initial start of heat mode, indoor blower will not be turned on immediately until indoor coil temperature senses a minimum temperature. This period usually takes 30 seconds to 3 minutes depending on the outdoor ambient temperature.

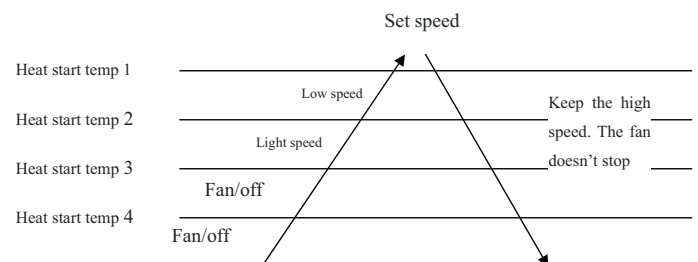

4 minutes after the indoor fan starts, the light or low speed will switch to the set speed.

In cold air proof operation, the fan remains on after startup.

Residual heat sending: the indoor fan will operate on low speed for 12 seconds.

The outdoor unit temperature sensors: outdoor ambient, defrost, suction line, and compressor discharge, used in conjunction with the indoor temperature sensors, indoor

ambient and tube, provide information to the outdoor control board to monitor the system and regulate the frequency of the compressor, EEV positioning, and outdoor fan speed to achieve the desired room temperature.

When heating has been satisfied, the outdoor unit compressor will turn off first and followed by the outdoor fan. The 4-way valve will de-energize 2 minutes after compressor stops.

The indoor unit fan will continue to run at minimum speed until indoor coil temperature reaches a minimum temperature and it will turn off.

If the system detects a malfunction, it may shut down or show an error code on the indoor unit display board and/or outdoor unit main board LED.

### Defrost

When the system initiates a call for defrost, the indoor fan motor stops. The indoor unit display will not change. Any indoor unit malfunctions will be ignored at this time. The system will cycle through the defrost operation. Any indoor unit malfunctions will be ignored until the compressor restarts and has been operating for 30 seconds. At the conclusion of the defrost cycle, the indoor fan will enter the cold air proof operation. Heat mode resumes.

### Automatic Heating Temperature Compensation

When the system enters heating mode, a temperature compensation adjustment is added to the operating parameter. This adjustment is canceled when exiting heat mode.

### Indoor unit

To enter the heat mode, point the infrared remote controller at the indoor unit and press the power button, then press the HEAT mode button if not already set to heat mode.

The signals received by the infrared receiver are relayed to the main board of the indoor unit to turn the system on and set it to heat mode.

The indoor unit main board will activate the display of the indoor unit, illuminating the display, indicating the room temperature and current status of the unit.

The indoor unit main board will signal the louver stepper motor to open the louver to a stationary position.

The indoor unit main board will power up the indoor fan motor after the outdoor unit has started and heating of the indoor coil has taken place (see cold air proof operation). The indoor fan motor has a feedback circuit which provides the indoor unit main board with information for controlling the speed of the fan motor.

### Temperature sensors

The indoor unit has two sensors that provide temperature information to the indoor unit main board. The sensors: an indoor ambient temperature sensor, and pipe temperature sensor, are used for controlling the system during heat mode.

The resistance values of the sensors will vary with temperature. The resistance to temperature values can be found using a temperature / resistance chart specific to the sensor being checked.

### Communication

The indoor and outdoor unit main boards communicate via a digital signal on the wire connected to terminal 3 of each unit. A splice or break in this wire will cause a communication error.

When a command is received from the remote control, the indoor unit main board communicates with the outdoor unit main board via the terminal 3 wire to perform the requested function.

### Outdoor unit

Upon a request for heat, the outdoor unit main board applies power to the 4-way valve, outdoor fan motor and compressor. Depending on system cycling, there may be up to a 3 minute wait period before the compressor and outdoor fan start.)

NOTE: Do not measure compressor voltages, damage to the meter may result.

If the ambient room temperature is above the set temperature, yet lower than 2°F above the set temperature, the system will adjust the running frequency of the compressor automatically according to changes in ambient temperature.

The outdoor unit main board also controls the position of the EEV (Electronic Expansion Valve) to regulate the flow of refrigerant to the indoor unit evaporator coil.

### Temperature sensors

Four temperature sensors located in the outdoor unit provide temperature information to the outdoor unit main board for control of the system during heat mode.

The outdoor ambient temperature sensor provides the temperature of the air drawn into the condenser coil of the outdoor unit.

The defrost temperature sensor provides the temperature sensed at the output of the condenser coil.

The suction line temperature sensor provides the temperature sensed at the incoming suction line pipe.

The compressor discharge sensor provides the temperature sensed at the discharge pipe of the compressor.

## Call to Terminate Heating

The system will call to terminate heating when the indoor ambient temperature sensor is equal to or higher than 2°F above the room set temperature. The indoor control board will communicate to the outdoor control board to de-energize the compressor. The outdoor fan will run for 60 seconds before stopping. The 4-way valve will de-energize 2 minutes after the compressor stops.

To stop heat mode, press the power button to turn the system off, or change to another mode.

## Auto Mode

With the system turned on, press the AUTO button on the remote control. The system will change to the auto mode of operation.

As the room is cooled or heated, the system will automatically switch between cool mode, fan mode, and heat mode. There is a minimum 15 minute operating time between mode changes.

## Dry Mode

### Overview

The temperature control range in Dry mode is 60°F - 86°F. This mode is used for the purpose of dehumidification.

(Tr = room temperature Ts = set temperature)

When  $Tr > Ts + 4°F$ , the compressor will turn on and the indoor fan will operate at the set speed.

When  $Ts \leq Tr \leq Ts + 4°F$ , the compressor will operate at the high dry frequency for 10 minutes, then at the low dry mode for 6 minutes. The indoor fan will operate at low speed.

When  $Tr < Ts$ , the outdoor unit will stop, and the indoor fan will stop for 3 minutes, then operate at the low speed option.

Automatic fan speed:

When  $Tr \geq Ts + 9°F$ , High speed

When  $Ts + 5.4°F \leq Tr < Ts + 9°F$ , Medium speed

When  $Ts + 3.6°F \leq Tr < Ts + 5.4°F$ , Low speed

When  $Tr < Ts + 3.6°F$ , Light speed

Note: TURBO and QUIET mode must be set using the remote controller.

If the outdoor fan is stopped, the indoor fan will pause for 3 minutes.

If the outdoor fan is stopped for more than 3 minutes, and the compressor is still operating, the system will change to light speed mode.

### Indoor unit

To enter the dry mode, point the infrared remote control at

the indoor unit and press the power button, then press the DRY mode button if not already set to dry mode.

The signals received by the infrared receiver are relayed to the main board of the indoor unit to turn the system on and set it to dry mode.

The indoor unit main board will activate the display of the indoor unit, illuminating the display, indicating the room temperature and current status of the unit.

The indoor unit main board will signal the louver stepper motor to open the louver to either a stationary position, or one of several oscillating modes.

As the louver opens, the indoor unit main board will power up the indoor fan motor, operating the fan at the speed last set. The indoor fan motor has a feedback circuit which provides the indoor unit main board with information for controlling the speed of the fan motor.

### Temperature sensors

The indoor unit has two sensors that provide temperature information to the indoor unit main board. The sensors: an indoor ambient temperature sensor, and pipe temperature sensor, are used for controlling the system during dry mode. The resistance values of the sensors will vary with temperature. The resistance to temperature values can be found using a temperature / resistance chart specific to the sensor being checked.

### Communication

The indoor and outdoor unit main boards communicate via a digital signal on the wire connected to terminal 3 of each unit. A splice or break in this wire will cause a communication error.

When a command is received from the remote control, the indoor unit main board communicates with the outdoor unit main board via the terminal 3 wire to perform the requested function.

### Outdoor unit

Upon a request for dry mode, the outdoor unit main board applies power to the outdoor fan motor and compressor. Depending on system cycling, there may be up to a 3 minute wait period before the compressor and outdoor fan start.)

**WARNING:** Do not measure compressor voltages, damage to the meter may result.

The outdoor unit main board also controls the position of the EEV (Electronic Expansion Valve) to regulate the flow of refrigerant to the indoor unit evaporator coil.

## Temperature sensors

Four temperature sensors located in the outdoor unit provide temperature information to the outdoor unit main board for control of the system during dry mode.

The outdoor ambient temperature sensor provides the temperature of the air drawn into the condenser coil of the outdoor unit.

The defrost temperature sensor provides the temperature sensed at the output of the condenser coil.

The suction line temperature sensor provides the temperature sensed at the incoming suction line pipe.

The compressor discharge sensor provides the temperature sensed at the discharge pipe of the compressor.

To stop dry mode, press the power button to turn the system off, or change to another mode.

## Defrost Operation

Defrost cycle will initiate if any of three conditions are met.

$T_e$  = Defrost temperature sensor

$T_{ao}$  = Outdoor ambient temperature sensor

$T_{es}$  = Condensation point temperature

- 1)  $T_{es} \geq 23^\circ\text{F}$ , and  $T_e \leq 23^\circ\text{F}$
- 2)  $5^\circ\text{F} \leq T_{es} < 23^\circ\text{F}$ , and  $T_e \leq T_{es}$
- 3)  $T_{es} < 5^\circ\text{F}$  and  $T_e \leq 5^\circ\text{F}$

$T_{es} = C \times T_{ao} - a$

$T_{ao} < 32^\circ\text{F}$ ,  $C = .08$

$T_{ao} > \text{or} = 32^\circ\text{F}$ ,  $C = .06$

$a = 6$

The minimum time interval between defrost cycles is 45 minutes.

When the defrost cycle begins, the following conditions take place:

1. The compressor will stop for 1 minute
2. The outdoor fan will continue to operate at high speed.
3. After 50 seconds, the 4-way valve will shift to the cool mode position.
4. 5 seconds later the outdoor fan will stop.
5. After 1 minute, the compressor will start.

The outdoor unit will now defrost.

The defrost cycle runs continuously for approximately 10 minutes.

The system will exit the defrost cycle if any of the following conditions are met:

1. The condenser maintains a temperature above  $45^\circ\text{F}$  for 80

seconds.

2. The condenser maintains a temperature above  $54^\circ\text{F}$  for 5 seconds.

Upon exiting the defrost cycle, the following conditions will take place:

1. The compressor will stop.
2. The outdoor fan will operate at high speed.
3. 50 seconds later the 4-way valve will shift to the heat mode position.
4. 60 seconds later the compressor will start.

The system resumes normal operation.

## Protection Functions

### 1. TTC high temperature protection

The compressor discharge pipe sensor (exhaust temp) senses the temperature of the refrigerant exiting the compressor. The sensed temperature received from the sensor by the control circuitry will cause the compressor frequency to increase or decrease. (see chart below). If a temperature of  $\geq 230^\circ\text{F}$  is sensed for 20 seconds, an exhaust overheating protection error code will be indicated at the outdoor unit.

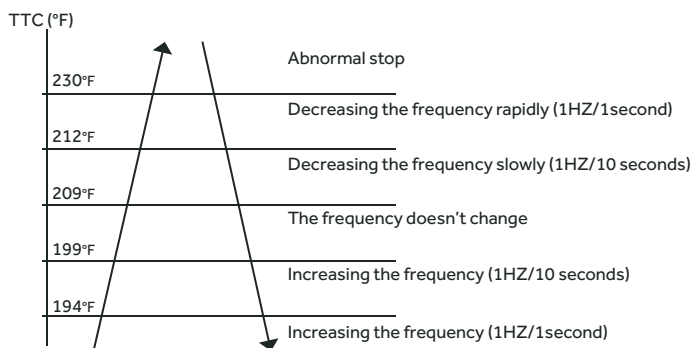

### 2. Overheating protection for indoor unit

The indoor tube sensor senses the temperature of the indoor heat exchanger.

If the temperature sensed is greater than  $133^\circ\text{F}$ , the compressor frequency will decrease to prevent overheating of the heat exchanger.

If  $T_c \geq 133^\circ\text{F}$  for more than 10 seconds, the compressor will stop and an error code will be indicated at the outdoor unit. If the compressor is off for 3 minutes and  $T_c < 118^\circ\text{F}$ , the compressor will restart.

If the temperature sensed is lower than  $118^\circ\text{F}$ , the protection function is canceled.

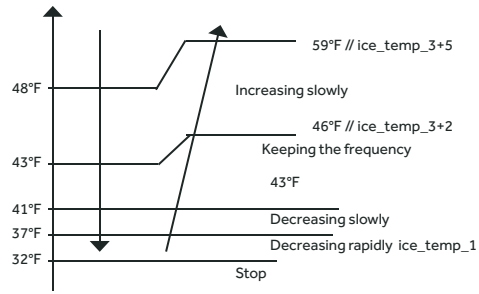
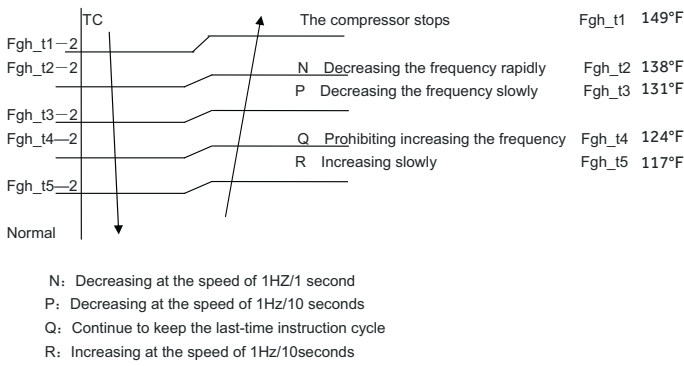

### 3. Compressor overcurrent protection

If the current draw of the compressor at start-up is greater than the overcurrent point listed on the chart below for approximately 3 seconds, the compressor will stop, and a code will be indicated at the outdoor unit. After 3 minutes the compressor will try to restart. If the overcurrent condition occurs 3 times in 20 minutes, the system will lock-out, and a code will be indicated at the outdoor unit. It will be necessary to remove power to the system to reset the lock-out condition.

The frequency of the compressor may change depending on the current draw at start-up. Refer to the chart and current/Hz table shown below.

- Greater than current 1: Decreases 1Hz/second
- Greater than current 2: Decreases 0.1Hz/second
- Greater than current 3: No change

Model	Over current Point	Decline Speed Current 1	Decline Speed Current 2	Decline Speed Current 3
09K	~11A	~8.5A	~8A	~7A
12K	~13A	~10A	~9.5A	~8.5A
18K	~15A	~12A	~11.5A	~10.5A
24K	~17A	~13.5A	~13A	~12A

### 4. Anti-freeze protection of the indoor heat exchanger

The temperature sensed by the indoor unit tube sensor is used to determine what frequency the compressor is to run at for freeze protection.

Tpg\_indoor: indoor unit pipe sensor temperature  
 When Tpg\_indoor < Tpg1, the frequency of the compressor decreases at the rate of 1HZ / 1 second.  
 When Tpg\_indoor < Tpg2, the frequency of the compressor decreases at the rate of 10HZ / 10 seconds.  
 When Tpg\_indoor begins to rise again, and Tpg2 ≤ Tpg\_indoor ≤ Tpg3, the frequency of the compressor does not change.  
 When Tpg3 < Tpg\_indoor < Tpg4, the frequency of the compressor increases at the rate of 1HZ / 10 seconds.  
 Example: if Tpg\_indoor ≤ 32°F sustains for 2 minutes, the outdoor unit will stop and indicate an underload malfunction code at the outdoor unit. The compressor stops for a minimum of 3 minutes. When Tpg\_indoor > Tpg4, the compressor will restart.





Table of Contents

**Step 1 - Preparation ..... 34**  
*Required Tools for Installation ..... 34*  
*Procedure for Selecting the Location ..... 34*  
*Clearances of Indoor and Outdoor Units ..... 34*

**Step 2 - Installation of the Indoor Unit ..... 35**  
*Attaching the Mounting Plate to the Wall..... 35*  
*Mounting the Indoor Unit Onto the Wall Plate ..... 36*  
*Electrical Connections for the Indoor Unit ..... 36*

**Step 3 - Installation of the Outdoor Unit..... 36**  
*Attaching Drain Elbow to Outdoor Unit ..... 36*  
*Electrical Connections for the Outdoor Unit ..... 36*

**Step 4 - Interconnecting the Indoor and Outdoor Units ..... 37**  
*Piping..... 37*

**Step 5 - Leak Test and Evacuation..... 38**  
*Leak Test..... 38*  
*System Evacuation ..... 38*

**Step 6 - Charging..... 39**  
*Refrigerant Charge Label ..... 39*  
*System Test ..... 39*  
*Check Items for Test Run ..... 39*

**Section 7 - Explaining Operation to the End User..... 40**

**Section 8 - System Specifications..... 40**

**Section 9 - Seacoast Application ..... 41**

## Step 1 - Preparation

### Required Tools for Installation

- Drill
- Wire Snipper
- Hole Saw 2 3/4"
- Vacuum pump
- Soap-and-water solution or gas leakage detector
- Torque wrench
- 17mm, 22mm, 26mm
- Tubing cutter
- Flaring tool
- Razor knife
- Measuring tape
- Level
- Micron gauge
- Nitrogen
- Mini-Split AD-87 Adapter (1/4" to 5/16")
- A - Non-adhesive Tape
- B - Adhesive Tape
- C - Saddle (L.S.) with screws
- D - Electrical wiring
- E - Drain hose (Included)
- F - Insulation
- G - Piping hole cover (Included)

### Procedure for Selecting the Location

- Choose a place solid enough to bear the weight and vibration of the unit and where the operation noise will not be amplified.
- Choose a location where the hot air discharged from the unit or the operation noise and will not cause a nuisance to the neighbors of the user.
- There must be sufficient space for carrying the unit into and out of the site.
- There must be sufficient space for air passage and no obstructions around the air inlet and air outlet.
- The site must be free from the possibility of flammable gas leakage in a nearby place.
- Locate the unit to avoid noise and discharged hot air will not annoy the neighbors.
- Install units, power cords and inter-unit cables at least 10ft away from television and radio sets. This is to prevent interference to images and sounds. (Noise may be heard even if they are more

than 10ft away depending on radio wave conditions.)

- Since drain flows out of the outdoor unit, do not place anything under the unit that must be kept away from moisture.

#### Note:

- 1) Cannot be installed hanging from ceiling or stacked.
- 2) If installing on a high place such as a roof, with a fence or guard rail around it.
- 3) If there is a potential for accumulated snow to block the air inlet or heat exchanger, install the unit on a higher base.
- 4) R-410A refrigerant is a safe, nontoxic and nonflammable refrigerant. However, if there is a concern about a dangerous level of refrigerant concentration in the case of refrigerant leakage, add extra ventilation.
- 5) Avoid installing the outdoor unit where corrosive gases, such as sulfur oxides, ammonia, and sulfurous gas, are produced. If unavoidable, consult with an installation specialist about using a corrosion-proof or anti-rust additive to protect the unit coils.

## Clearances of Indoor and Outdoor Units

This picture is for reference only. Your product may look different. Read this manual before installation. Explain the operation of the unit to the user according to this manual.

The models adopt HFC free refrigerant R410A

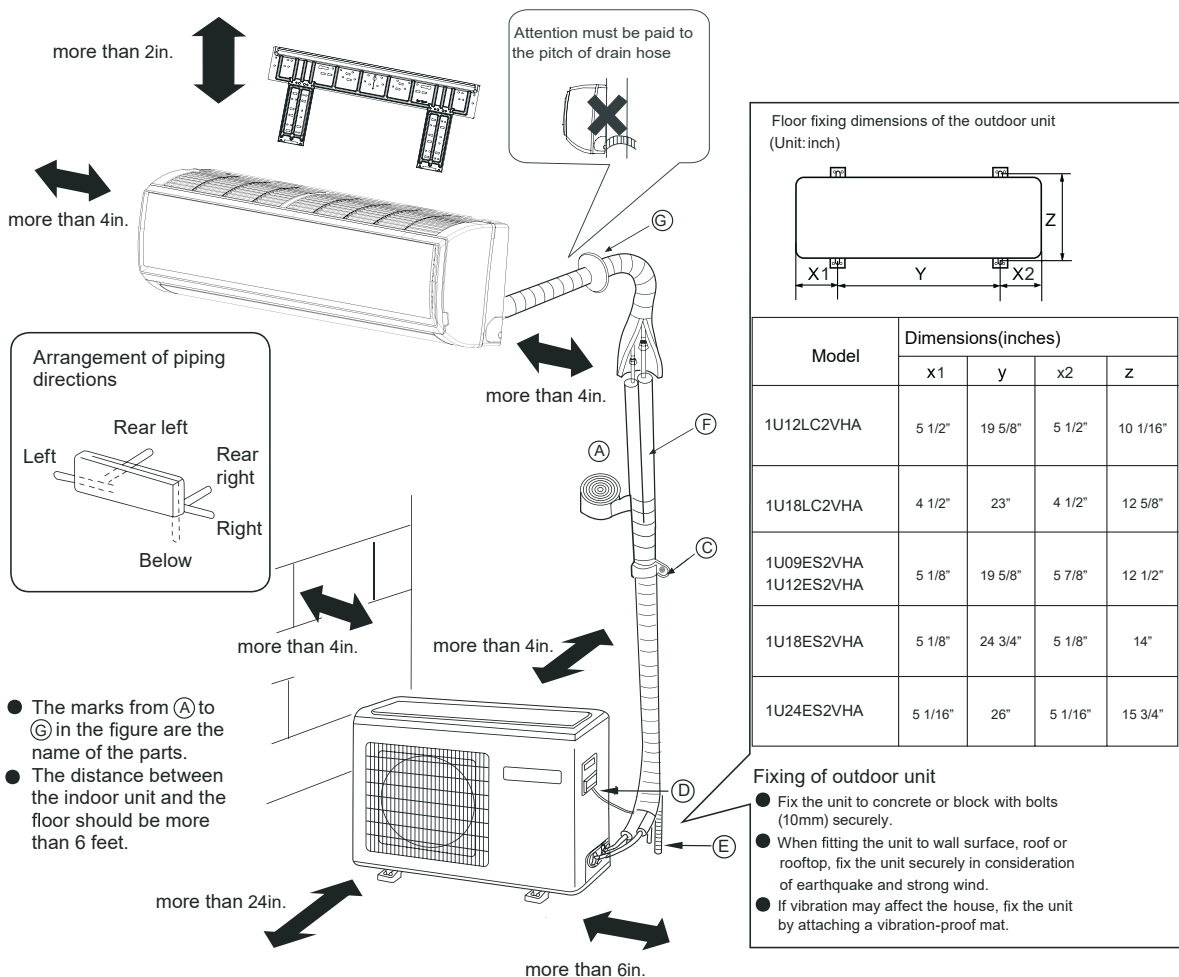

## Attaching the Mounting Plate to the Wall

### 2.1 Step 2.1

Using a stud sensor, locate and mark the stud positions in the wall where the indoor unit is to be mounted.

### 2.2 Step 2.2

Place the mounting plate on the wall in the desired location taking into account the minimum clearances necessary for proper operation.

Using a level, verify the mounting plate is horizontal and mark the screw locations.

### 2.3 Step 2.3

Screw the mounting plate to the wall.

The piping for the indoor unit may be routed to the unit from one of several directions. Left, Left Rear, Right, Right Rear, or Below (Illustration 1).

### 2.4 Step 2.4

Knockouts are provided on the case for Left, Right, and Right Below.

### Drilling the hole through the wall for left rear or right rear installation

#### 2.5 Step 2.5A & 2.5B

Measure and mark the location where the piping hole is to be drilled.

#### 2.6 Step 2.6

Drill the piping hole using a hole saw of the correct diameter. Angle the drill with a downward pitch to the outside wall so that the outside hole will be 1/4" lower than the inside hole, giving the hole the proper angle for condensate drainage.

#### 2.7 Step 2.7

Install the piping hole cover flange at the hole opening on the inside wall.

NOTE: The cover flange may require modification to fit properly behind the wall unit housing.

#### 2.8 Step 2.8A & 2.8B

Bundle the refrigerant piping, drain piping and wiring with tape and pass the bundle through the piping hole.

NOTE: When bundling the power cable, leave sufficient length available in the indoor unit to make the connections to the terminal block.



Step 2.1

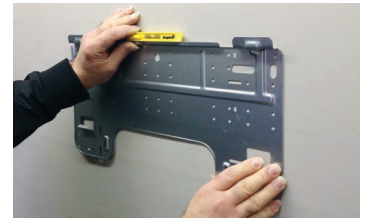

Step 2.2



Step 2.3



Step 2.4

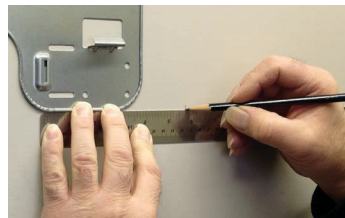

Step 2.5A

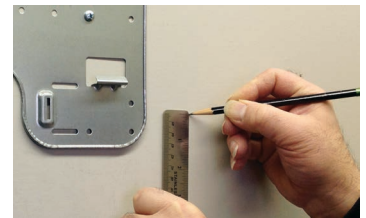

Step 2.5B



Step 2.6



Step 2.7



Step 2.8A

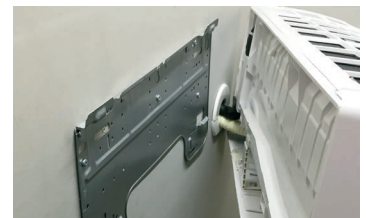

Step 2.8B

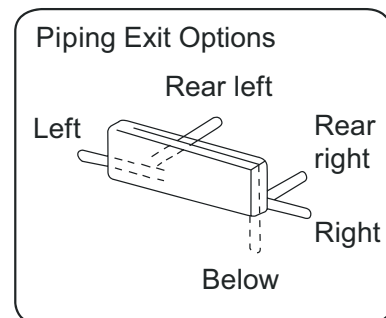

Illustration 1

## Mounting the Indoor Unit Onto the Wall Plate

### 2.9 Step 2.9

With the top of the indoor unit closer to the wall, hang the indoor unit on the upper hooks of the mounting plate. Slide the unit slightly side to side to verify proper placement of the indoor unit on the mounting plate. Rotate the lower portion of the indoor unit to the mounting plate, and lower the unit onto the lower hooks of the mounting plate. (Illustration 2) Verify the unit is secure.



Step 2.9



Step 2.10

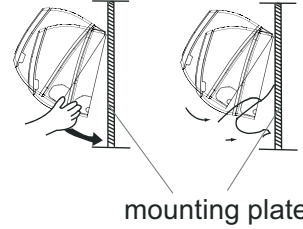

mounting plate

Illustration 2

### 2.10 Step - 2.10

Slightly raise the entire unit vertically, pull the lower portion of the unit off the lower hooks of the mounting plate and away from the wall, then lift the upper portion of the unit off the upper hooks of the wall plate.

## Electrical Connections for the Indoor Unit

### 2.11 Step - 2.11A & 2.11B

To make the electrical connections for the indoor unit, two cover plates must be removed. Raise the front cover to access the screws to remove these covers.

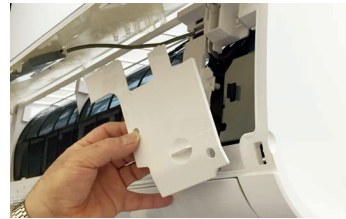

Step 2.11A

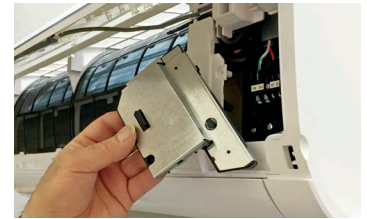

Step 2.11B

### 2.13 Step - 2.13

Access the four conductor cable through the cover plate opening and make the wiring connections noting the wire color used on each terminal. The color of each wire must match the same positions on the terminal block of the outdoor unit. (Illustration 3)



Step 2.12



Step 2.13A

Failure to wire the system correctly may lead to improper operation or component damage.

### 2.14 Step - 2.14A & 2.14B

After the terminal block wiring is completed, replace both cover plates.



Step 2.13B

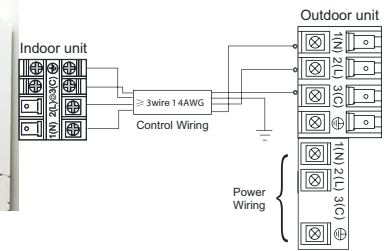

Illustration 3

## Step 3 - Installation of the Outdoor Unit

### Attaching Drain Elbow to Outdoor Unit

(Heat Pump models only)

### 3.1 Step - 3.1

If attaching the supplied drain elbow to the outdoor unit, do so prior to attaching the refrigerant lines and wiring. Extension piping to attach to this fitting is field supplied.



Step 3.1

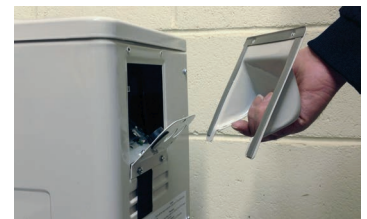

Step 3.2

### Electrical Connections for the Outdoor Unit

### 3.2 Step - 3.2

Remove the cover plate of the outdoor unit to expose the terminal block connections.

**3.3 Step - 3.3**

Connect the wiring for both the power source and indoor wiring.

Wire the system according to applicable national / local codes.

Verify that the wiring connections for the indoor unit match wire for wire.

(1-1, 2-2, 3-3, Gnd-Gnd). Failure to wire the system correctly may lead to improper operation or component damage.



Step 3.3



Step 3.4

**3.4 Step - 3.4**

Replace the cover plate.

**Step 4 - Interconnecting the Indoor and Outdoor Units**

\*See Steps 2.11 - 2.13 & 3.2 - 3.4 for connecting the electrical.

**Piping**

The standard lineset length is 25ft. If the installation length is different, adjust the refrigerant charge by .2 oz / ft. for the 9K, 12K, 18K, and 24K model. (Illustration 4)

Cut the lineset to length, flare and attach the piping to the outdoor unit valves.

Torque the fittings to the specifications shown in the torque chart.

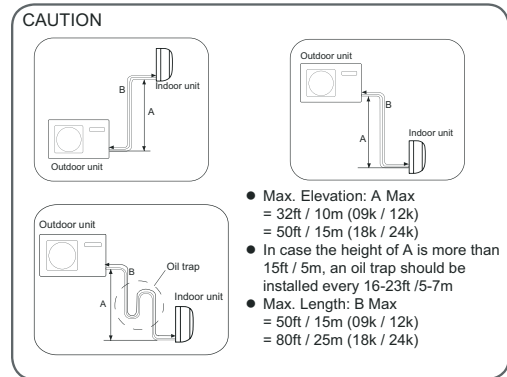

Illustration 4

**4.1 Step - 4.1**

Refrigerant piping connections for the mini-split system are made utilizing flare connections. Follow standard practices for creating pipe flares. When cutting and reaming the tubing, use caution to prevent dirt or debris from entering the tubing. Remember to place the nut on the pipe before creating the flare.



Step 4.1

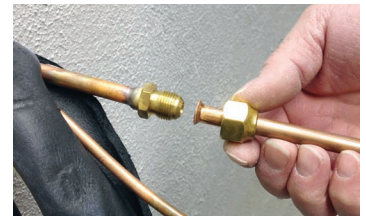

Step 4.2

**4.2 Step - 4.2**

To join the lineset piping together, directly align the piping flare to the fitting on the other pipe, then slide the nut onto the fitting and tighten. Misalignment may result in a leaking connection.

**2.17 Step - 4.3**

Two wrenches are required to join the flare connections, one standard wrench, and one torque wrench. See Table 1 for the specific torque per piping diameter.

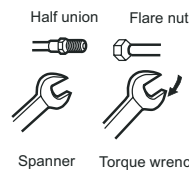

Forced fastening without careful centering may damage the threads and cause a leakage of gas.

Pipe Diameter(φ)	Fastening torque
Liquid side 6.35mm(1/4")	18N.m/13.3Ft.lbs
Liquid/Gas side 9.52mm(3/8")	42 N.m/30.1Ft.lbs
Gas side 12.7mm(1/2")	55N.m/40.6Ft.lbs
Gas side 15.88mm(5/8")	60 N.m/44.3Ft.lbs

Table 1

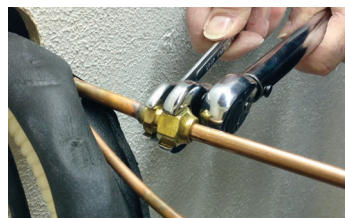

Step 4.3

### Leak Test

**Hazard of Explosion!** Never use an open flame to detect gas leaks. Explosive conditions may occur. Use a leak test solution or other approved methods for leak testing. Failure to follow recommended safe leak test procedures could result in death or serious injury or equipment or property damage.

Use only dry nitrogen with a pressure regulator for pressurizing unit. Do not use acetylene, oxygen or compressed air or mixtures containing them for pressure testing. Do not use mixtures of a hydrogen containing refrigerant and air above atmospheric pressure for pressure testing as they may become flammable and could result in an explosion. Refrigerant, when used as a trace gas should only be mixed with dry nitrogen for pressurizing units. Failure to follow these recommendations could result in death or serious injury or equipment or property damage.

#### 5.1 Step - 5.1

Using a tank of nitrogen with attached regulator, charge the system with 150 PSIG of dry nitrogen. Use adapter AD-87 (field supplied) to connect to the valve. Check for leaks at the flare fittings using soap bubbles or other detection methods. If a leak is detected, repair and recheck. If no leaks are detected, proceed to evacuate the system.

### System Evacuation

#### 5.2 Step - 5.2

Attach a manifold gauge, micron gauge, and vacuum pump to the suction line port using adapter AD-87 (field supplied). (Illustration 5)

**Evacuate the system to 350 microns.**

**Close the vacuum pump valve and check the micron gauge. If the gauge rises above 500 microns in 60 seconds, evacuation is incomplete or there is a leak in the system. If the gauge does not rise above 500 microns in 60 seconds, evacuation is complete.**

#### 5.3 Step - 5.3

Remove the adapter and hose connection from the suction line port, and replace the cap.

#### 5.4 Step - 5.4A & 5.4B

Remove the cap from the liquid line valve. Using the hex wrench, open the valve, then replace and tighten the cap.

#### 5.5 Step - 5.5A & 5.5B

Remove the cap from the suction line valve. Using the hex wrench, open the valve, then replace and tighten the cap.

#### 5.6 Step - 5.6

Wrap the lineset, drain line, and wiring starting at the bottom of the bundle with an overlap type wrap, concluding at the



Step 5.1

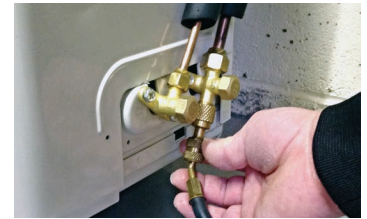

Step 5.2

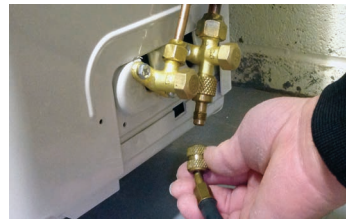

Step 5.3



Step 5.4A



Step 5.4B



Step 5.5A



Step 5.5B



Step 5.6

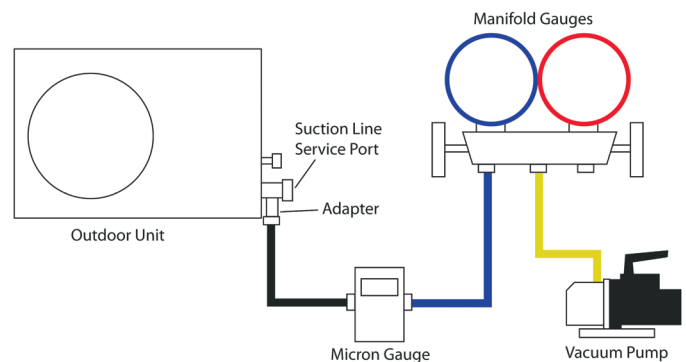

Illustration 5

pipng hole. Use a sealant to seal the piping hole opening to prevent weather elements from entering the building. (Illustration 6)

Verify the condensate drain line has a constant pitch downward for proper water flow. There should be no kinks or rises in the tubing which may cause a trapping effect resulting in the failure of the condensate to exit the piping.

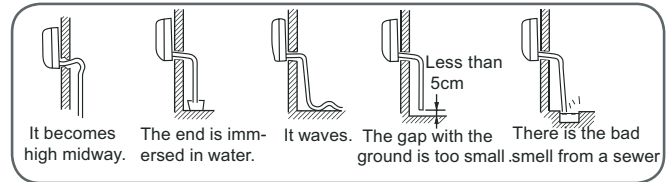

Illustration 6

## Step 6 - Charging

See Steps 5.2 - 5.5 for evacuating the system prior to charging. The standard lineset length is 25ft. If the installation length is different, adjust the refrigerant charge by .2 oz / ft. for the 9K, 12K, 18K, and 24K model. (Step 4 - Illustration 4)

### Refrigerant Charge Label

This product contains fluorinated greenhouse gases covered by the Kyoto Protocol. Do not vent into the atmosphere.

Refrigerant type: R410A

GWP\* value: 1975

GWP = global warming potential

Please fill in with indelible ink,

- 1 the factory refrigerant charge of the product
- 2 the additional refrigerant amount charged in the field and
- 1+2 the total refrigerant charge on the refrigerant charge label supplied with the product.

The filled out label must be adhered in the proximity of the product charging port (e.g. onto the inside of the stop valve cover).

- A - contains fluorinated greenhouse gases covered by the Kyoto Protocol
- B - factory refrigerant charge of the product: see unit name plate
- C - additional refrigerant amount charged in the field
- D - total refrigerant charge
- E - outdoor unit
- F - refrigerant cylinder and manifold for charging

Contains fluorinated greenhouse gases covered by the Kyoto Protocol \_\_\_\_\_ A

**R410A**

1 =  oz \_\_\_\_\_ B

2 =  oz \_\_\_\_\_ C

---

1+2 =  oz \_\_\_\_\_ D

F E

### System Test

Please kindly explain to our customers how to operate through the instruction manual.

### Check Items for Test Run

Put check mark  in boxes

- No gas leak from linesets?
- Are the linesets insulated properly?
- Are the connecting wirings of indoor and outdoor firmly inserted to the terminal block?
- Is the connecting wiring of indoor and outdoor firmly fixed?
- Is condensate draining correctly?
- Is the ground wire securely connected? Is the indoor unit securely fixed?
- Is power source voltage correct according to local code?
- Is there any noise?
- Is the lamp normally lighting?
- Are cooling and heating (when in heat pump) performing normally?
- Is the operation of room temperature sensor normal?

## Section 7 - Explaining Operation to the End User

- Using the OPERATING INSTRUCTIONS, explain to the user how to use the air conditioner (the remote controller, removing the air filters, placing or removing the remote controller from the remote controller holder, cleaning methods, precautions for operation, etc.)
- Recommend that the user read the OPERATING INSTRUCTIONS carefully.

## Section 8 - System Specifications

Model Name	System	09ES	12ES	18ES	24ES
Model Name	Outdoor	1U09ES2VHA	1U12ES2VHA	1U18ES2VHA	1U24ES2VHA
	Indoor	AW09ES2VHA	AW12ES2VHA	AW18ES2VHA	AW24ES2VHA
Cooling	Rated Capacity Btu/hr	9,000	12,000	17,000	22,000
	Capacity Range Btu/hr	3800-12100	4,100-14,680	7,000-23,000	6,500-28,600
	Rated Power Input W	610 (280-1150)	910 (290-1,200)	1,350 (420-2,100)	1,760 (540-2,760)
	SEER	23.5	23.0	21.0	20.0
	EER	14.5	12.5	12.6	12.5
	Moisture Removal Pt./h	2.50	3.40	4.23	5.92
Heating	Rated Heating Capacity 47°F Btu/hr	10,000	16,000	22,000	27,700
	Heating Capacity Range Btu/hr	4100-15000	4,430-19,800	5,400-26,400	6,800-34,800
	Rated Power Input W	650 (290-1200)	1,250 (300-1,300)	1830 (400-2,900)	2,350 (640-3,170)
	HSPF	12.0	11.0	11.0	10.0
	Rated Heating Capacity 17°F Btu/hr	7,400	12,220	14,000	18,500
	Max. Heating Capacity 17°F Btu/hr	10,000	13,120	19,600	26,000
	Max. Heating Capacity 5°F Btu/hr	10,000	10,160	14,900	20,500
Operating Range	Cooling °F(°C)	14~115(-10~46)	14~115(-10~46)	14~115(-10~46)	14~115(-10~46)
	Heating °F(°C)	-4~75(-20~24)	-4~75(-20~24)	-4~75(-20~24)	-4~75(-20~24)
Power Supply	Voltage, Cycle, Phase V/Hz/-	208-230/60/1	208-230/60/1	208-230/60/1	208-230/60/1
Outdoor Unit	Compressor Type	DC inverter Driven Rotary			
	Maximum Fuse Size A	15	15	30	30
	Minimum Circuit Amp A	15	15	18	21
	Outdoor Fan Speed RPM	300-900	300-900	300-850	300-800
	Outdoor Noise Level dB	51	51	52	53
	Dimension: Height in (mm)	23 1/2 (597)	23 1/2 (597)	27 7/16 (697)	30 (762)
	Dimension: Width in (mm)	30 11/16 (780)	30 11/16 (780)	35 (890)	36 3/16 (920)
	Dimension: Depth in (mm)	11 7/16 (290)	11 7/16 (290)	13 7/8 (353)	15 1/8 (385)
	Weight (Ship/Net)- lbs (kg)	84.8/78.2 (38.5/ 35.5)	84.8/78.2 (38.5/ 35.5)	105.4/96.6 (47.8/43.8)	134.5/125.7 (61/57)
Indoor Unit	Fan Speed Stages	5 + Auto	5 + Auto	5 + Auto	5 + Auto
	Airflow (Turbo/High/Med/Low/ Quiet) CFM	440/410/350/290/265	610/530/440/410/350	710/650/560/440/410	710/650/560/440/410
	Motor Speed (Turbo/High/Med/Low/ Quiet) RPM	1150/1050/900/750/650	1150/1050/900/750/650	1100/950/850/750/700	1250/1150/1000/850/800
	Indoor Sound Level dB (Turbo/High/ Med/Low/Quiet)	44/40/35/31/23	45/41/36/32/23	48/46/42/36/34	49/47/42/36/34
	Dimension: Height in (mm)	12 1/4 (310)	12 1/4 (310)	13 1/4 (336)	13 1/4 (336)
	Dimension: Width in (mm)	35 7/16 (900)	35 7/16 (900)	43 7/8 (1115)	43 7/8 (1115)
	Dimension: Depth in (mm)	8 7/16 (215)	8 7/16 (215)	9 9/16 (243)	9 9/16 (243)
	Weight (Ship/Net)- lbs (kg)	30.9/25.4 (14/ 11.5)	30.9/25.4 (14/ 11.5)	43.2/35.3 (19.6/16)	45.4/37.5 (20.6/17)
Refrigerate Line	Connections	Flare	Flare	Flare	Flare
	Liquid O.D. in	1/4	1/4	1/4	1/4
	Suction O.D. in	3/8	3/8	1/2	1/2
	Factory Charge Oz	38.8	38.8	52.2	74.1
	Maximum Line Length Ft / m	50/15	50/15	83/25	83/25
	Maximum Height Ft / m	33/10	33/10	50/15	50/15



## Section 9 - Seacoast Application

- The outdoor unit should be installed at least ½ mile away from the salt water, including seacoasts and inland waterways. If the unit installed from ½ mile to 5 miles away from the salt water, including seacoasts and inland waterways, please follow the installation instruction below.
- Install the outdoor unit in a place (such as near buildings etc.) where it can be protected from sea breeze which can damage the outdoor unit.

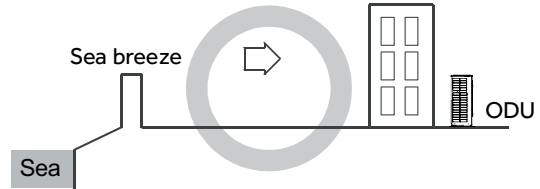
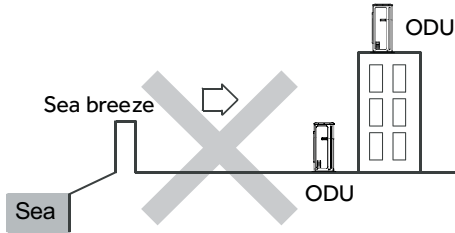

- If you cannot avoid installing the outdoor unit by the seashore, construct a protection wall around it to block the sea breeze.

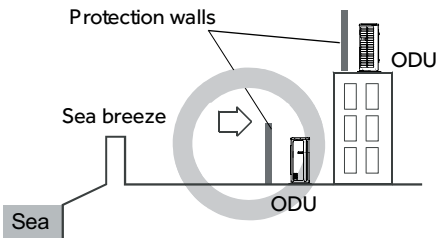

- A protection wall should be constructed with a solid material such as concrete to block the sea breeze and the height and the width of the wall should be 1.5 times larger than the size of the outdoor unit. Also, secure over 28 in (700mm) between the protection wall and the outdoor unit for exhausted air to ventilate.

- Install the outdoor unit in a place where water can drain smoothly.
- If you cannot find a place satisfying above conditions, please contact manufacturer. Make sure to clean the sea water and the dust on the outdoor unit heat exchanger.

*[This page intentionally left blank.]*

Table of Contents

**Error Codes and Description Indoor Display ..... 44**  
*Indoor Unit Display ..... 44*

**Indoor AC Fan Motor Malfunction ..... 45**  
*Indoor Unit Display ..... 45*  
 E14 ..... 45

**Outdoor DC Fan Motor Fault ..... 46**  
*Outdoor Unit Display ..... 46*  
 LED1 Flashes 9 Times ..... 46

**IPM Protection ..... 47**  
*Outdoor Unit Display ..... 47*  
 LED1 Flashes 2 Times ..... 47

**Over-current of the Compressor ..... 47**  
*Outdoor Unit Display ..... 47*  
 LED1 Flashes 3 or 24 or 25 Times ..... 47

**The Communication Fault Between IPM and Outdoor PCB ..... 48**  
*Outdoor Unit Display ..... 48*  
 LED1 Flash 4 Times ..... 48

**Power Supply Too High or Too Low ..... 49**  
*Outdoor Unit Display ..... 49*  
 LED1 Flashes 6 Times ..... 49

**Overheat Protection for Discharge Temperature ..... 50**  
*Outdoor Unit Display ..... 50*  
 LED1 Flashes 8 Times ..... 50

**Communication Fault Between Indoor and Outdoor Units ..... 50**  
*Indoor Unit Display ..... 50*  
 E7 ..... 50  
*Outdoor Unit Display ..... 50*  
 LED1 Flashes 15 Times ..... 50

**Loss of Synchronism Detection ..... 51**  
*Outdoor Unit Display ..... 51*  
 LED1 Flashes 18 or 19 Times ..... 51

**Indoor Unit Overload in Heating Mode ..... 51**  
*Outdoor Unit Display ..... 51*  
 LED1 Flashes 18 or 19 Times ..... 51

**Checking System Components ..... 52**

**Checking Outdoor Unit Components ..... 52**  
*Checking the Outdoor Unit Sensors ..... 52*  
*Checking the Reversing Valve Coil ..... 52*  
*Checking the DC Fan Motor ..... 52*  
*Checking the EEV Stepper Motor ..... 52*  
*Checking the PFC Reactor ..... 52*  
*Checking the Compressor Windings ..... 53*

**Checking Indoor Unit Components ..... 53**  
*Checking the Indoor Unit Sensors ..... 53*  
*Checking the Up/Down Stepper Motor ..... 53*  
*Checking the Left Stepper Motor ..... 53*  
*Checking the Indoor DC Fan Motor ..... 54*

## Indoor Unit Display

Error codes will be display on the indoor unit in place of the set temperature.



	Code Indication		Description
	Indoor	Outdoor (LED1 flash times)	
<b>Indoor &amp; Outdoor</b>	E7	15	Communication fault between indoor and outdoor units
<b>Indoor Malfunction</b>	E1	/	Room temperature sensor failure
	E2	/	Heat-exchange sensor failure
	E4	/	Indoor EEPROM error
	E14	/	Indoor fan motor malfunction
<b>Outdoor Malfunction</b>	F12	1	Outdoor EEPROM error
	F1	2	The protection of IPM
	F22	3	Overcurrent protection of AC electricity for the outdoor model
	F3	4	Communication fault between the IPM and outdoor PCB
	F19	6	Power voltage is too high or low
	F27	7	Compressor has a locked rotor or stopped momentary
	F4	8	Overheat protection for exhaust temperature
	F8	9	Outdoor DC fan motor fault
	F21	10	Frost-removing temperature sensor failure
	F7	11	Suction temperature sensor failure
	F6	12	Ambient temperature sensor failure
	F25	13	Exhaust temperature sensor failure
	F11	18	Deviate from the normal for the compressor
	F28	19	Loop of the station detect error
	F2	24	Overcurrent of the compressor
	F23	25	Overcurrent protection for single-phase of the compressor
F36	39	Middle part of condenser temperature sensor failure	

## Indoor Display

### E14

This is caused by an indoor motor or indoor PCB fault

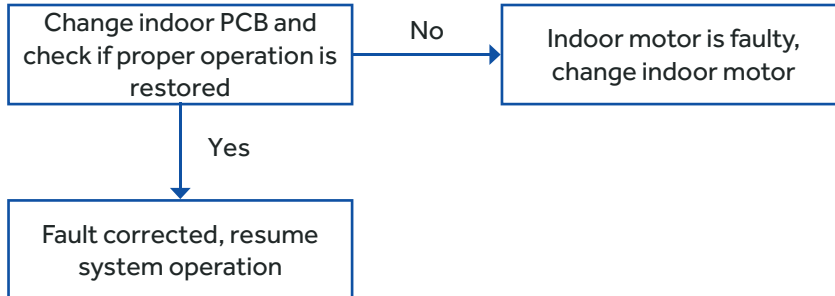

**Spare Parts:**  
Indoor PCB  
Indoor motor

## Outdoor Display

### LED1 Flashes 9 Times

This is caused by an outdoor motor or outdoor PCB fault

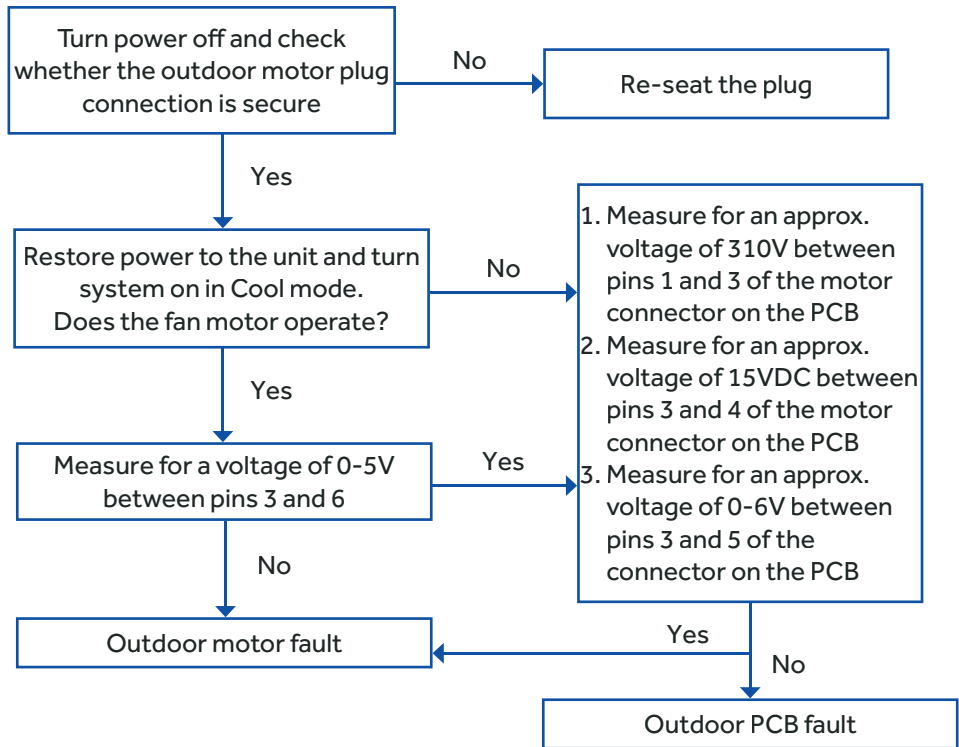

**Spare Parts:**  
Outdoor PCB  
Outdoor motor

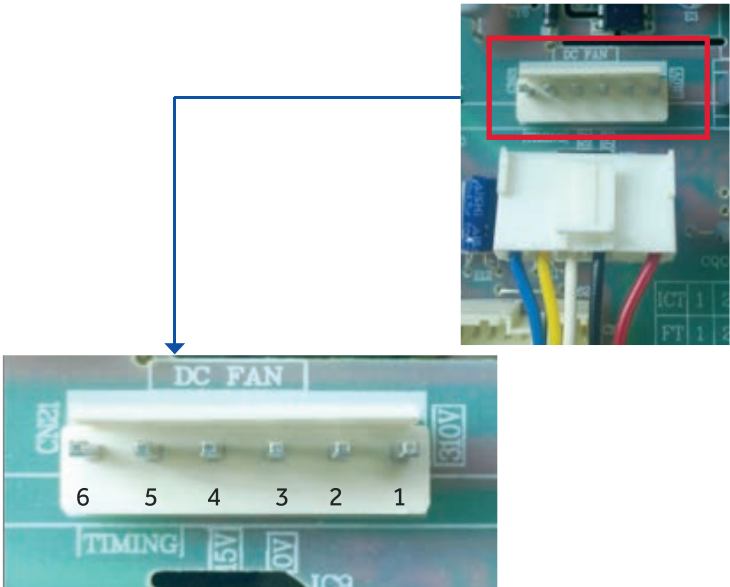

Outdoor Display

**LED1 Flashes 2 Times**

Under this error, please ensure the refrigerant system pressure is normal with no blockages, then replace power module

**Spare Parts:**  
Power module  
Refrigerant

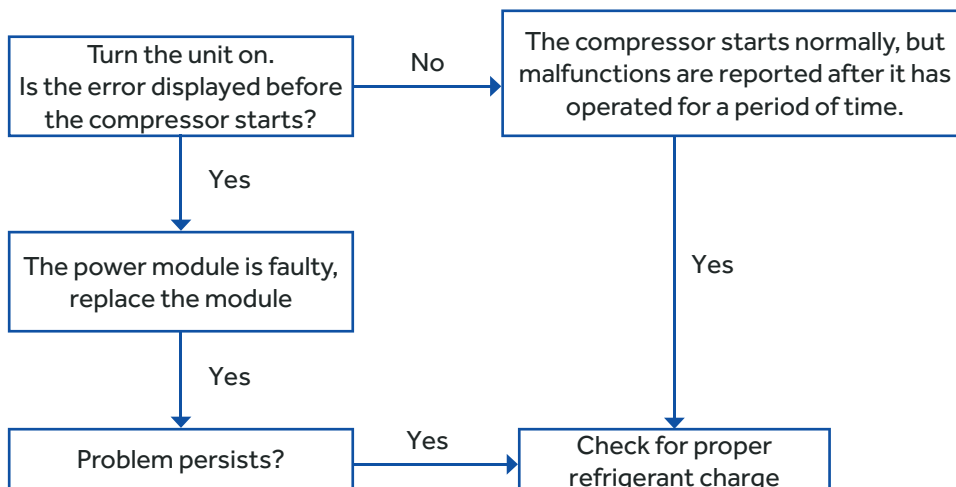

Over-current of the Compressor

Outdoor Display

**LED1 Flashes 3 or 24 or 25 Times**

**Spare Parts:**  
Power module  
Refrigerant

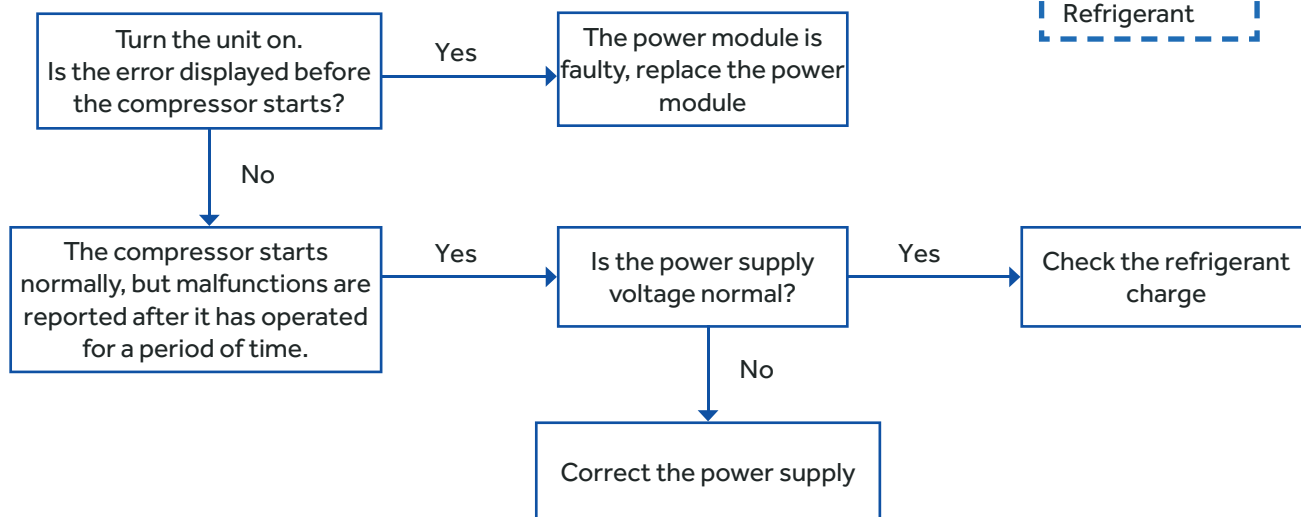

Outdoor Display

LED1 Flash 4 Times

**Spare Parts:**  
Power module  
Outdoor PCB

1) Check the plugs of MODULE COM and MODULE POWER on the outdoor PCB and IPM modules for secure connections  
2) Check the P & N wires between the outdoor PCB and IPM modules for secure connections

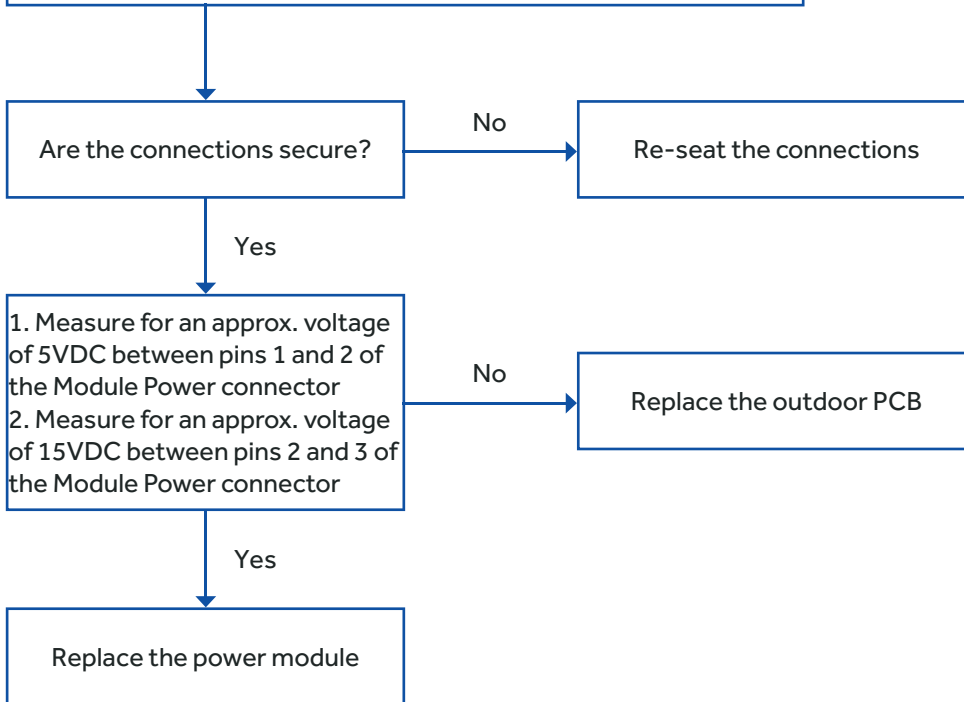



Outdoor Display

LED1 Flashes 6 Times

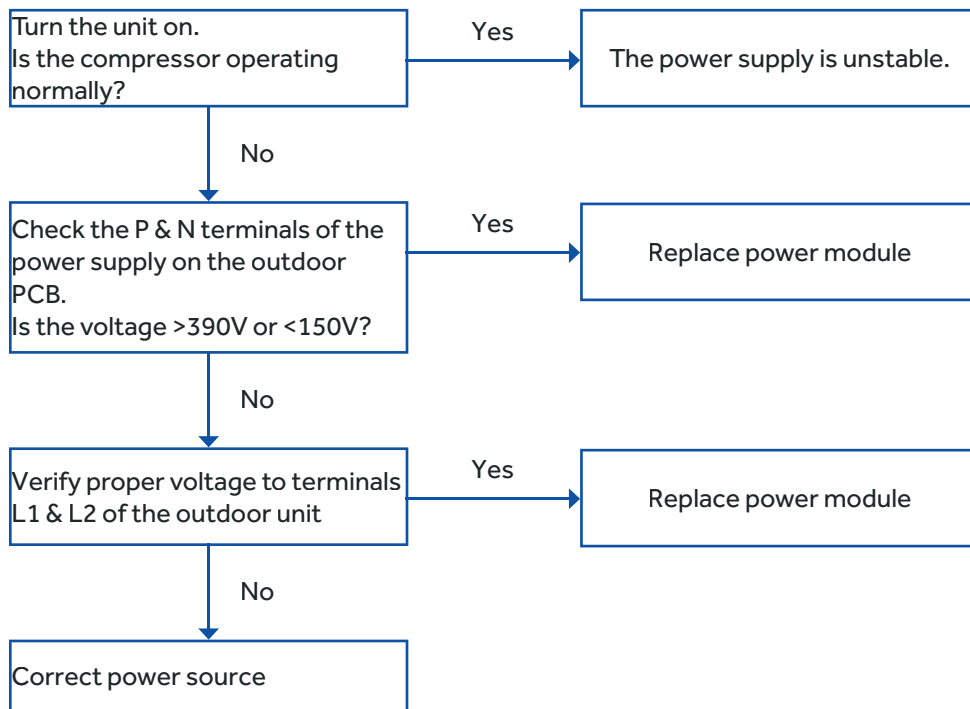

**Spare Parts:**  
Power module

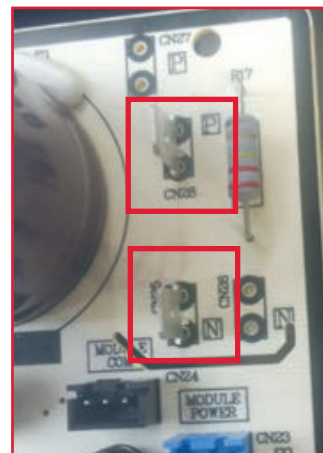

## Overheat Protection for Discharge Temperature

### Outdoor Display

#### LED1 Flashes 8 Times

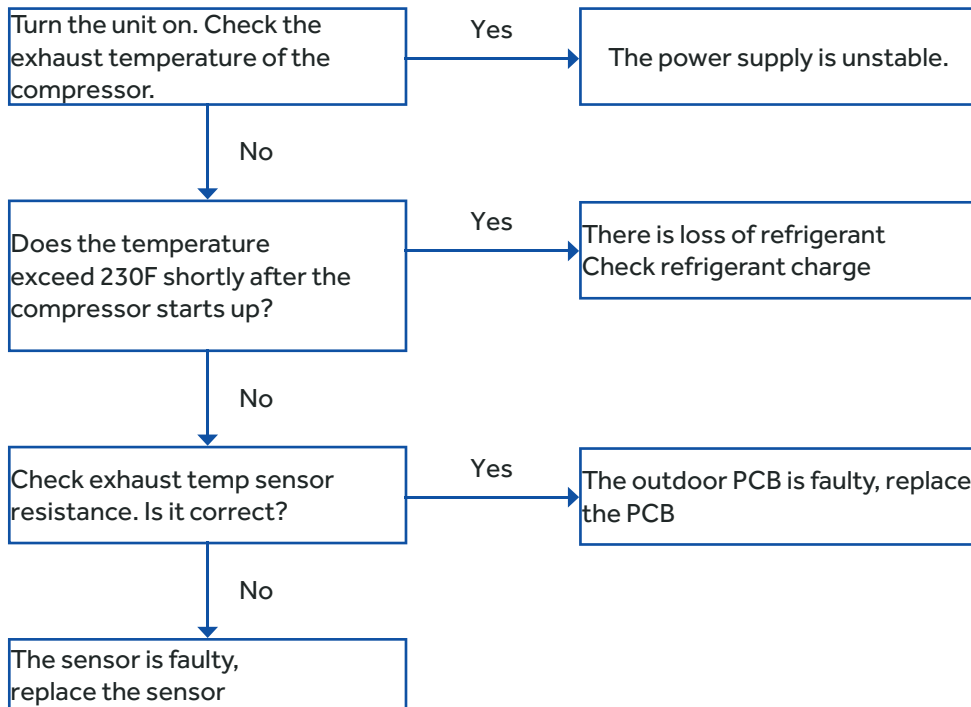

**Spare Parts:**  
Outdoor PCB  
Exhaust sensor

## Communication Fault Between Indoor and Outdoor Units

### Indoor Display

### Outdoor Display

#### E7

#### LED1 Flashes 15 Times

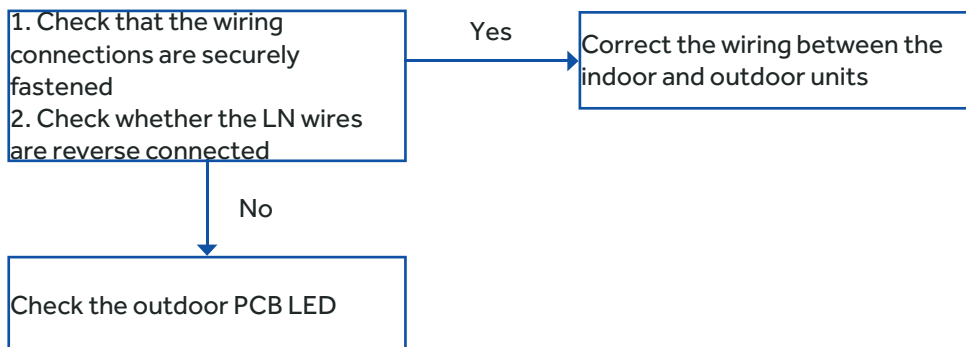

**Spare Parts:**  
Indoor PCB  
Outdoor PCB  
Power module

LED	LED 1	LED 2	Solution
ON/OFF	OFF	ON	Outdoor PCB fault
ON/OFF	ON	ON	This is caused by Outdoor PCB or Indoor PCB fault. Change one part firstly, it still unsolved, change another one.
ON/OFF	OFF	OFF	This is caused by Outdoor PCB or Power module fault. Change one part firstly, if still unsolved change another one.

## Outdoor Display

### LED1 Flashes 18 or 19 Times

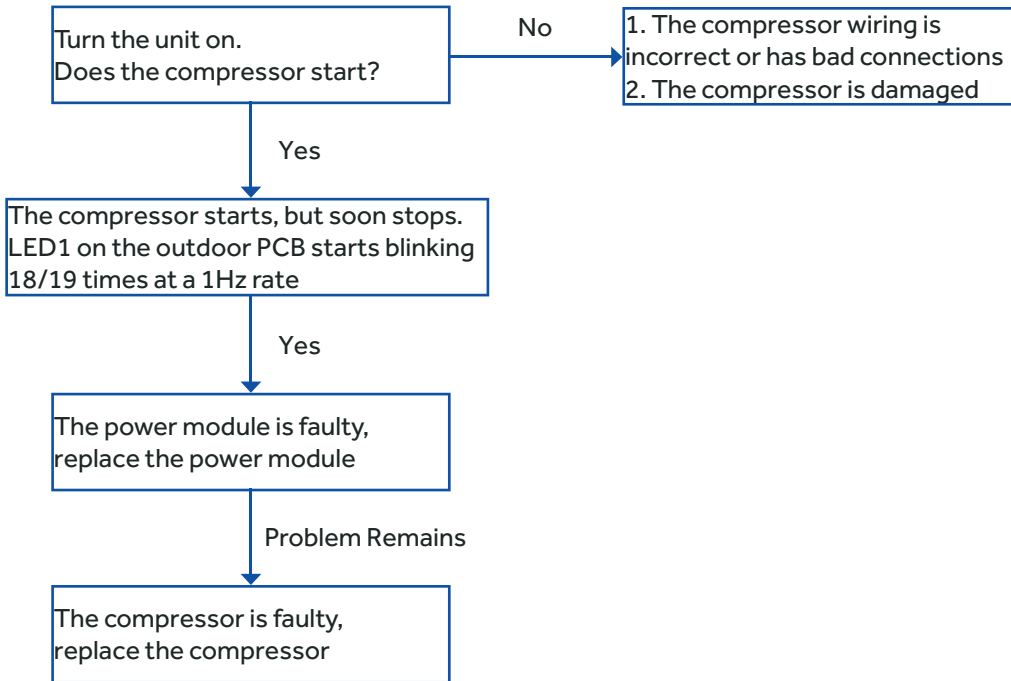

**Spare Parts:**  
Compressor  
Power module

## Indoor Unit Overload in Heating Mode

## Outdoor Display

### LED1 Flashes 18 or 19 Times

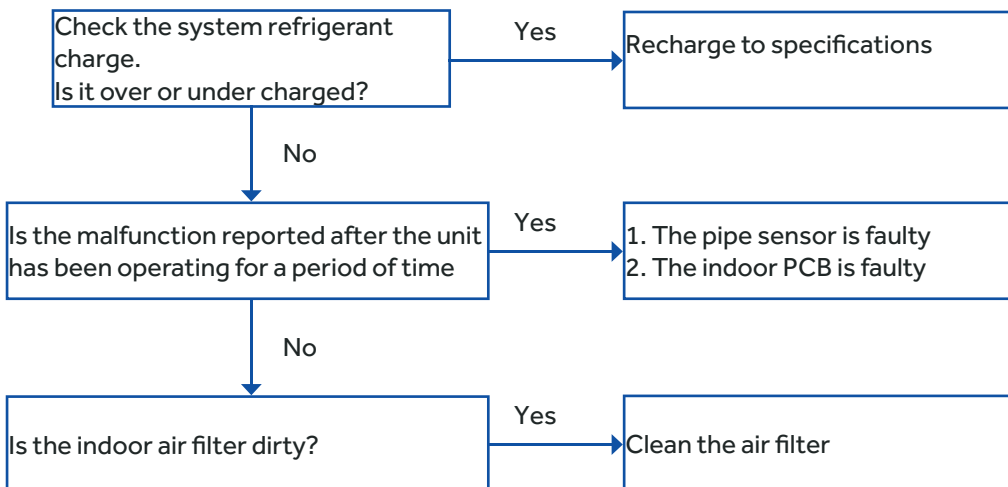

**Spare Parts:**  
Indoor pipe sensor  
Indoor PCB  
Refrigerant

## Checking System Components

NOTE: Component resistance readings shown in this section are for reference only. Actual resistance values may differ based on model being tested.

Component readings shown below are based on a model HSU12VHGL-W outdoor unit.

## Checking Outdoor Unit Components

Testing of the following components requires the use of an Ohmmeter and Temperature Probe. (Temperature probe is used during sensor testing only).

NOTE: When using the test probes, probe the back or side contacts of the plug to obtain the reading. Do not try to probe the connector end of the plug as this may damage the contacts of the plug.

### Checking the Outdoor Unit Sensors

NOTE: Use respective temperature / sensor chart for sensor type being tested.

Compressor discharge sensor  
Suction sensor  
Tube sensor (defrost temperature)  
Ambient sensor

#### Step 1

Disconnect the sensor plug from the control board for this test. Failure to do so may provide inaccurate readings.

#### Step 2

Using a temperature probe, determine the temperature of the sensor being tested.

#### Step 3

Using an Ohmmeter, check the resistance value of the sensor.

#### Step 4

Referring to the temperature / resistance table for the sensor being checked, verify the resistance value corresponds to the temperature checked in step 2.

Replace the sensor if the reading is open, shorted, or outside the specifications of the temperature / resistance table.

#### Step 5

Re-seat the plug on the connector at the conclusion of the test.

### Checking the Reversing Valve Coil

#### Step 1

Disconnect the reversing valve plug from the control board connector for this test. Failure to do so may provide inaccurate readings.

#### Step 2

Using an Ohmmeter, check the resistance value of the coil. The resistance value of the coil is 2.08K Ohms. Replace the valve coil if the reading is open, shorted, or a value

significantly different from 2.08K Ohms.

#### Step 3

Re-seat the plug on the connector at the conclusion of the test.

### Checking the DC Fan Motor

#### Step 1

Disconnect the DC Fan Motor plug from the control board connector for this test. Failure to do so may provide inaccurate readings.

#### Step 2

Refer to the chart shown below for plug pin combinations and resistance values.

Note: Test is polarity sensitive, adhere to probe placement as shown in chart.

		Red Test Lead					
		Red	---	Black	White	Yellow	Blue
Black Test Lead	Red		---	3.10 Meg	3.05 Meg	3.28 Meg	Charges to infinity
	---			---	---	---	---
	Black				43.85K	145.1K	Charges to infinity
	White					189.0K	Charges to infinity
	Yellow						Charges to infinity
Blue							

#### Step 3

Re-seat the plug on the connector at the conclusion of the test.

### Checking the EEV Stepper Motor

#### Step 1

Disconnect the EEV Stepper Motor plug from the control board connector for this test. Failure to do so may provide inaccurate readings.

#### Step 2

Refer to the chart shown below for plug pin combinations and resistance values.

	White	Yellow	Orange	Blue	Red	Grey
White		---	92.6 Ohm	---	47.0 Ohm	---
Yellow			---	93.1 Ohm	---	47.0 Ohm
Orange					46.5 Ohm	---
Blue						46.8 Ohm
Red						---
Grey						

#### Step 3

Re-seat the plug on the connector at the conclusion of the test.

### Checking the PFC Reactor

#### Step 1

Disconnect wires from terminals LI and LO of the power module board.

#### Step 2

Using an Ohmmeter, check the resistance value of the PFC Reactor. The resistance value of the coil is less than 1 Ohm. If the resistance value differs from this value, verify the

wiring and connections to the PFC Reactor as well as the PFC Reactor itself. Repair or replace as necessary.

### Step 3

Reconnect the wiring to the module board at the conclusion of the test.

Checking the Socket Protect component

### Step 1

Disconnect the Socket Protect plug from the control board connector for this test. Failure to do so may provide inaccurate readings.

### Step 2

Using an Ohmmeter, check the resistance value of the Socket Protect component. The resistance reading should be 0 Ohms. If it is not, replace the component.

### Step 3

Re-seat the plug on the connector at the conclusion of the test.

## Checking the Compressor Windings

### Step 1

Disconnect wiring from terminals U (black wire), V (white wire), and W (red wire) of the power module board.

### Step 2

Using an Ohmmeter, check the resistance value of the compressor windings. Measure between wires U (black wire) and V (white wire), U (black wire) and W (red wire), and V (white wire), and W (red wire).

The resistance value of the windings should be balanced (equal). If the resistance values are not equal, verify the wiring and connections to the compressor as well as the compressor itself. Repair or replace as needed.

### Step 3

Reconnect the wiring to the module board at the conclusion of the test.

NOTE: Component resistance readings shown in this section are for reference only. Actual resistance values may differ based on model being tested.

Component readings shown below are based on a model HSU12VHGL-G indoor unit.

## Checking Indoor Unit Components

Testing of the following components requires the use of an Ohmmeter and Temperature Probe (Temperature probe is used during sensor testing only).

NOTE: When using the test probes, probe the back or side contacts of the plug to obtain the reading. Do not try to probe the connector end of the plug as this may damage the contacts of the plug.

## Checking the Indoor Unit Sensors

NOTE: Use respective temperature / sensor chart for sensor

type being tested.

Tube sensor  
Ambient sensor

### Step 1

Disconnect the sensor plug from the control board for this test. Failure to do so may provide inaccurate readings.

### Step 2

Using a temperature probe, determine the temperature of the sensor being tested.

### Step 3

Using an Ohmmeter, check the resistance value of the sensor.

### Step 4

Referring to the temperature / resistance table for the sensor being checked, verify the resistance value corresponds to the temperature checked in step 2.

Replace the sensor if the reading is open, shorted, or outside the specifications of the temperature / resistance table.

### Step 5

Re-seat the plug on the connector at the conclusion of the test.

## Checking the Up/Down Stepper Motor

### Step 1

Disconnect the Up/Down Stepper Motor plug from the control board connector for this test. Failure to do so may provide inaccurate readings.

### Step 2

Refer to the chart shown below for plug pin combinations and resistance values.

	White	Yellow	Orange	Blue	Red	Grey
White		---	92.6Ohm	---	47.0 Ohm	---
Yellow			---	93.1 Ohm	---	47.0 Ohm
Orange					46.5 Ohm	---
Blue						46.8 Ohm
Red						---
Grey						

### Step 3

Re-seat the plug on the connector at the conclusion of the test.

## Checking the Left Stepper Motor

### Step 1

Disconnect the Left Stepper Motor plug from the control board connector for this test. Failure to do so may provide inaccurate readings.

### Step 2

Refer to the chart shown below for plug pin combinations and resistance values.

	Red	Orange	Yellow	Pink	Blue	Grey
Red		193.0 Ohm	189.5 Ohm	185.4 Ohm	191.5 Ohm	---
Orange			381.6 Ohm	377.4 Ohm	383.3 Ohm	47.0 Ohm
Yellow				373.9 Ohm	379.9 Ohm	---
Pink					375.8 Ohm	46.8 Ohm
Blue						---
Grey						

**Step 3**

Re-seat the plug on the connector at the conclusion of the test.

### ● Checking the Indoor DC Fan Motor

**Step 1**

Disconnect the DC Fan Motor plug from the control board connector for this test. Failure to do so may provide inaccurate readings.

**Step 2**

Refer to the chart shown below for plug pin combinations and resistance values.

Note: Test is polarity sensitive, adhere to probe placement as shown in chart.

		Red Test Lead						
		Pink	X	X	Black	White	Blue	Yellow
Black Test Lead	Pink		X	X	15.27Meg	15.46 Meg	Infinity	15.85 Meg
	X			X	X	X	X	X
	X				X	X	X	X
	Black					108.2K	Infinity	241.8K
	White						Infinity	349.5K
	Blue							5.14 Meg
	Yellow							
	Yellow							

**Step 3**

Re-seat the plug on the connector at the conclusion of the test.

Table of Contents

Outdoor Board Diagram ..... 58  
Outdoor Board Schematic ..... 59  
Indoor Board Diagram ..... 61  
Indoor Board Schematic ..... 62  
Module Board Schematic ..... 64  
Room and Pipe Sensor Tables ..... 65  
Ambient, Defrosting, Pipe Sensor Tables ..... 68  
Discharging Sensor Tables ..... 71

09K-12K

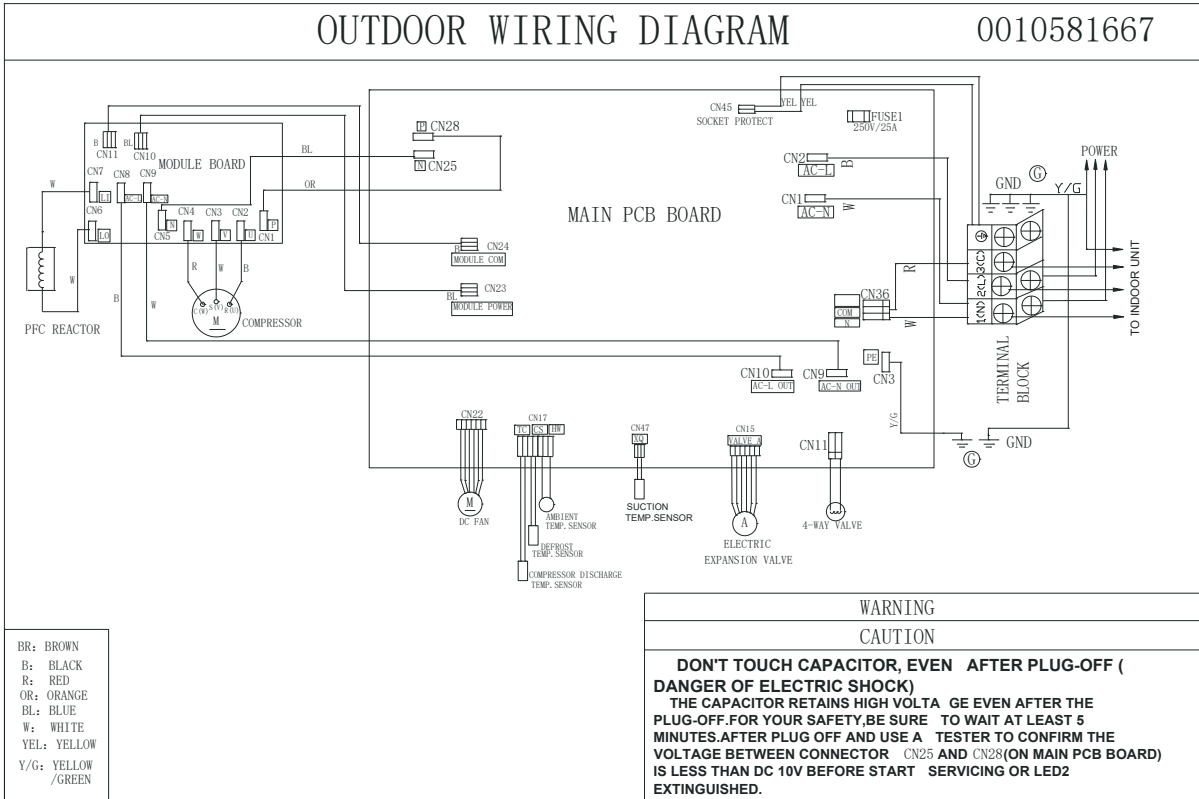

18K-24K

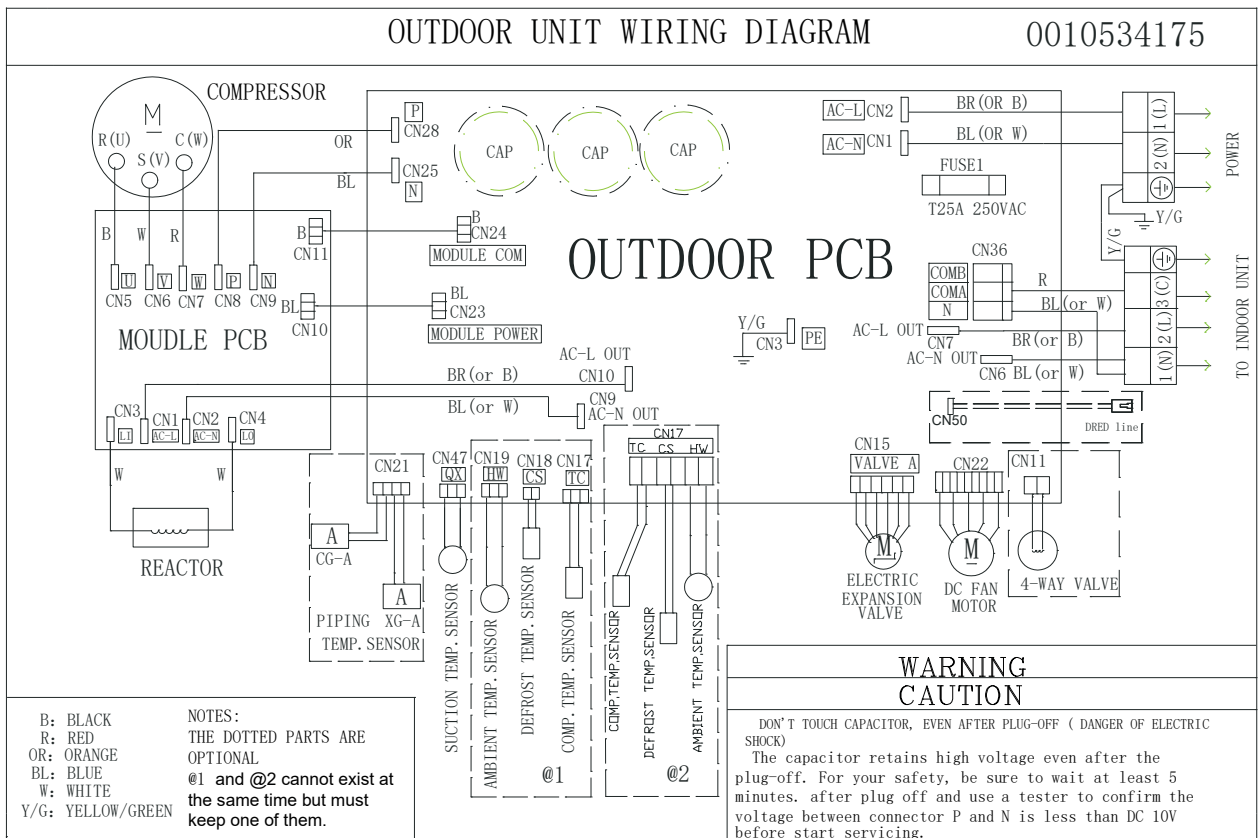



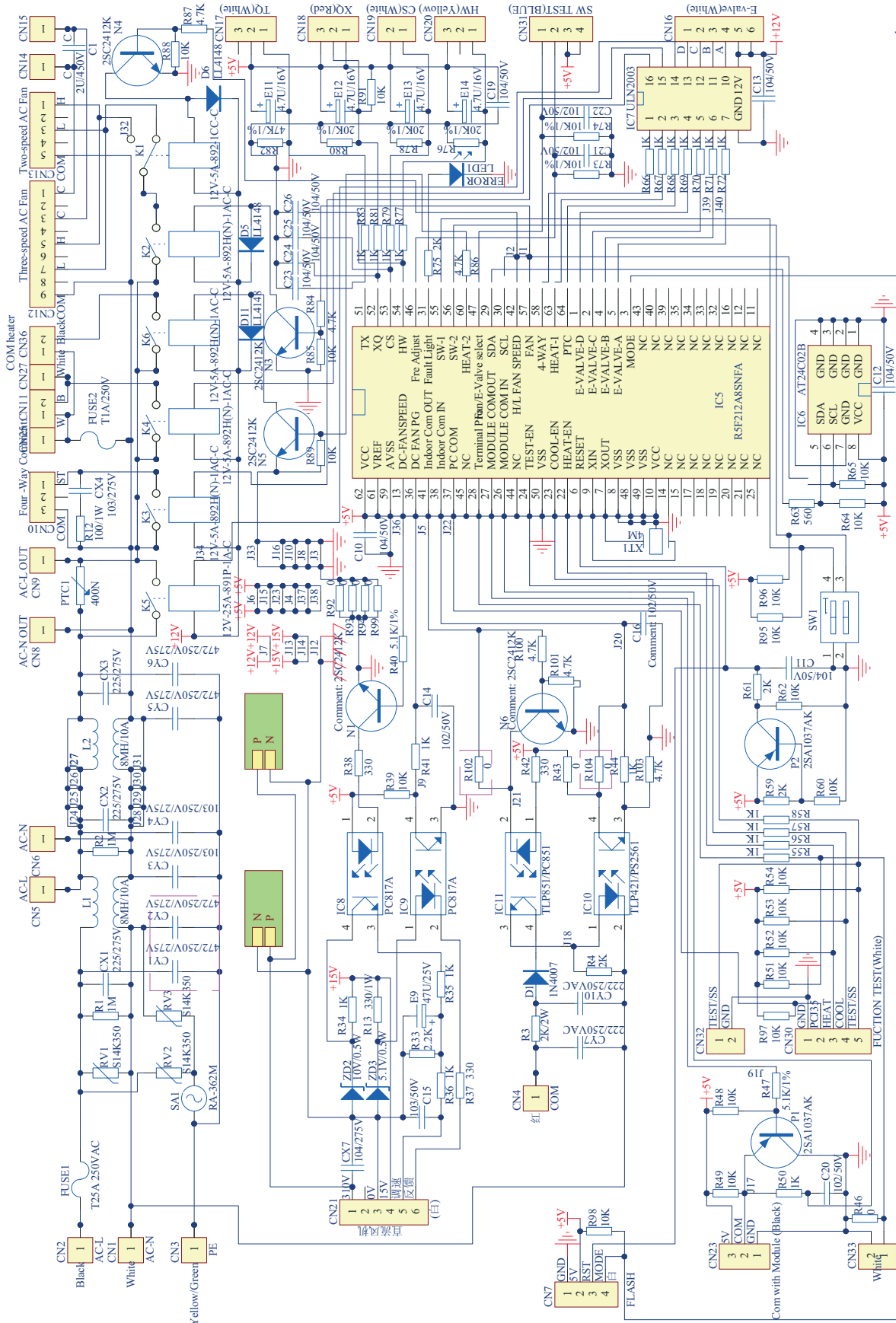

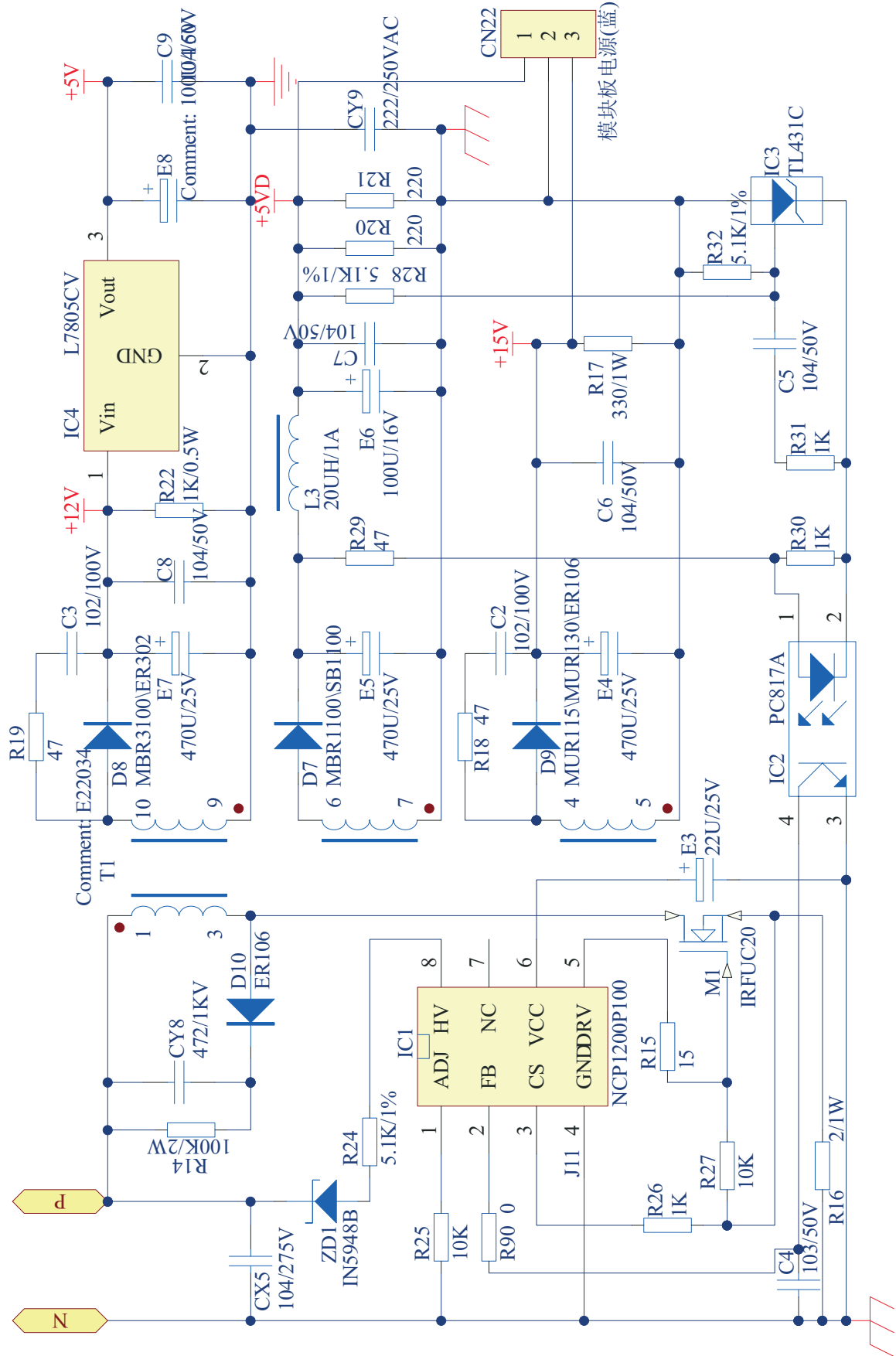

INDOOR UNIT DIAGRAM

0010561514

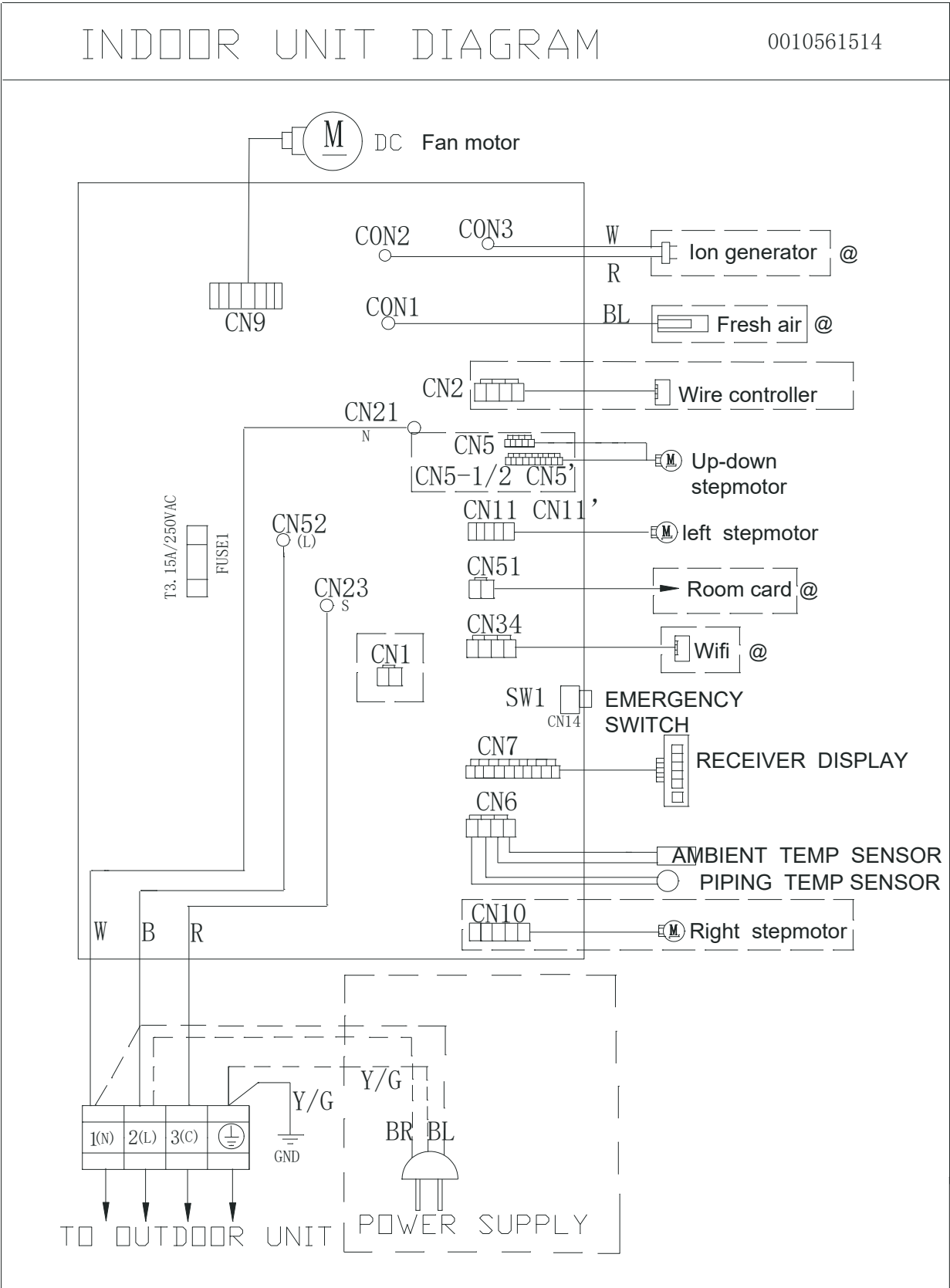

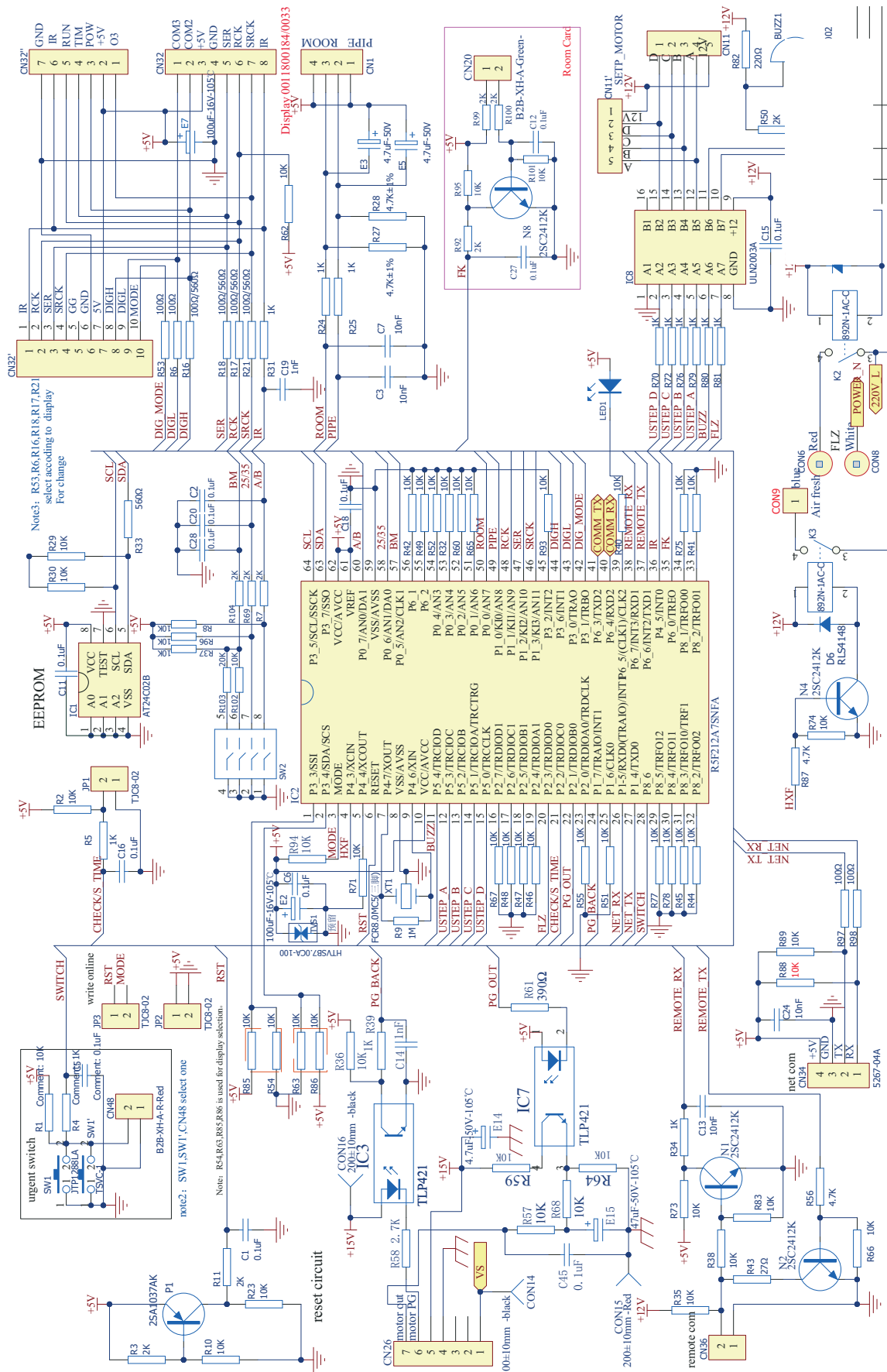

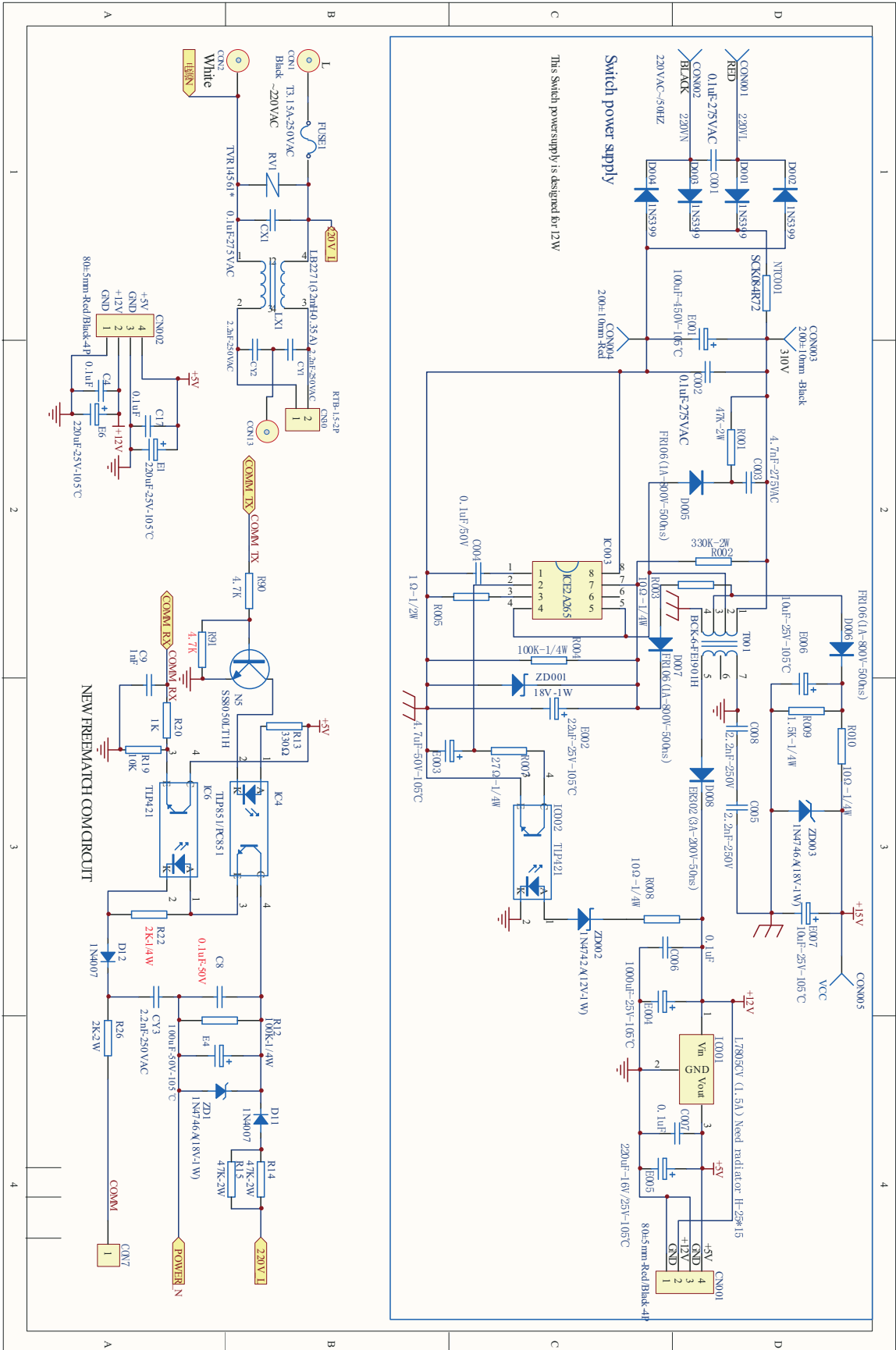

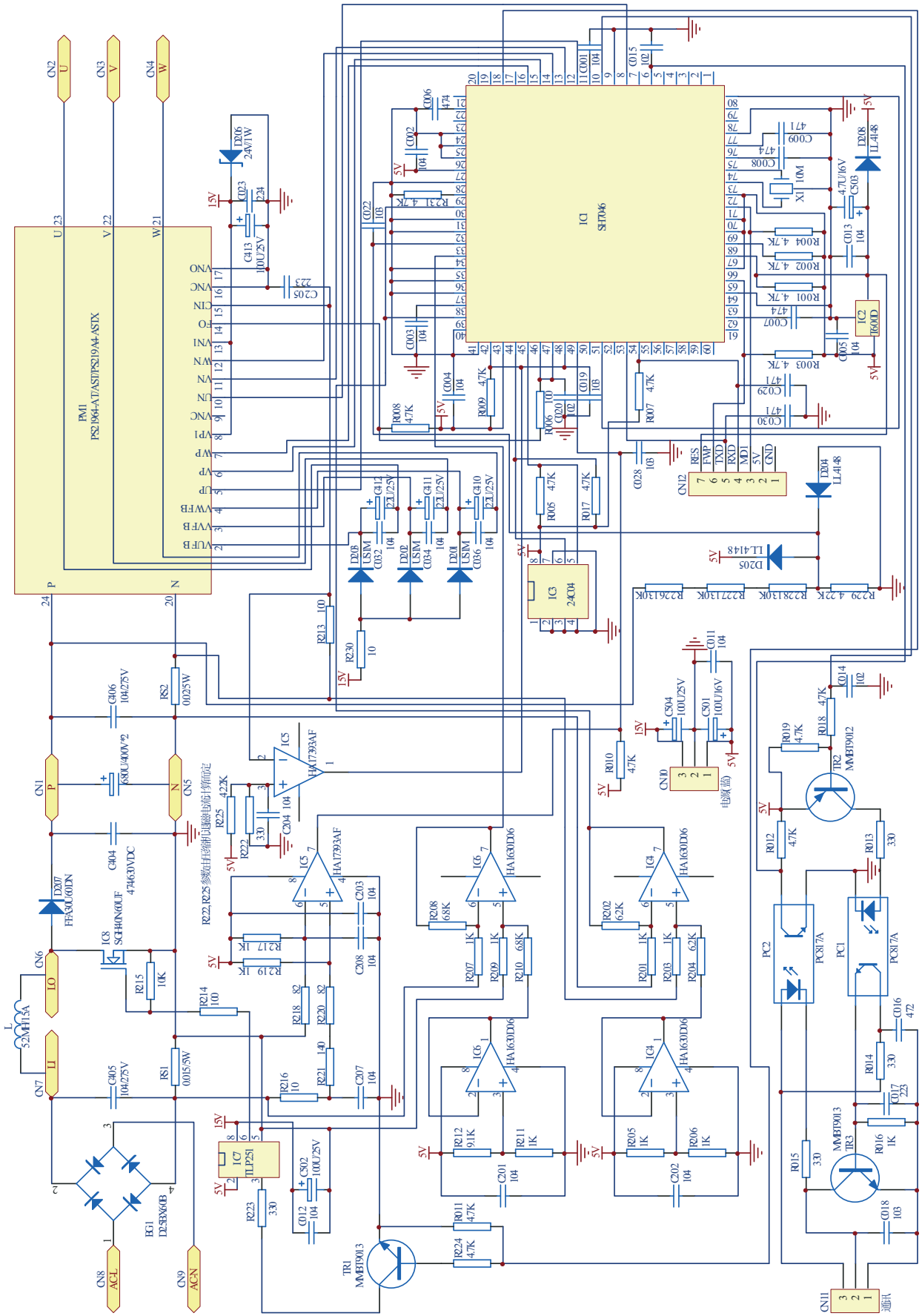

## Room and Pipe Sensor Tables

**R77° = 10KΩ±3%**

**B77°/122° = 3700K±3%**

Temp. °F	Temp. °C	Max.(KΩ)	Normal(KΩ)	Min.(KΩ)	Tolerance (°C)	
-22	-30	165.217	147.9497	132.3678	-1.94	1.75
-20.2	-29	155.5754	139.56	125.0806	-1.93	1.74
-18.4	-28	146.5609	131.7022	118.2434	-1.91	1.73
-16.6	-27	138.1285	124.3392	111.8256	-1.89	1.71
-14.8	-26	130.2371	117.4366	105.7989	-1.87	1.7
-13	-25	122.8484	110.9627	100.1367	-1.85	1.69
-11.2	-24	115.9272	104.8882	94.8149	-1.83	1.67
-9.4	-23	109.441	99.1858	89.8106	-1.81	1.66
-7.6	-22	103.3598	93.8305	85.1031	-1.8	1.64
-5.8	-21	97.6556	88.7989	80.6728	-1.78	1.63
-4	-20	92.3028	84.0695	76.5017	-1.76	1.62
-2.2	-19	87.2775	79.6222	72.5729	-1.74	1.6
-0.4	-18	82.5577	75.4384	68.871	-1.72	1.59
1.4	-17	78.123	71.501	65.3815	-1.7	1.57
3.2	-16	73.9543	67.7939	62.0907	-1.68	1.55
5	-15	70.0342	64.3023	58.9863	-1.66	1.54
6.8	-14	66.3463	61.0123	56.0565	-1.64	1.52
8.6	-13	62.8755	57.911	53.2905	-1.62	1.51
10.4	-12	59.6076	54.9866	50.6781	-1.6	1.49
12.2	-11	56.5296	52.2278	48.2099	-1.58	1.47
14	-10	53.6294	49.6244	45.8771	-1.56	1.46
15.8	-9	50.8956	47.1666	43.6714	-1.54	1.44
17.6	-8	48.3178	44.8454	41.5851	-1.51	1.42
19.4	-7	45.886	42.6525	39.6112	-1.49	1.4
21.2	-6	43.5912	40.58	37.7429	-1.47	1.39
23	-5	41.4249	38.6207	35.9739	-1.45	1.37
24.8	-4	39.3792	36.7676	34.2983	-1.43	1.35
26.6	-3	37.4465	35.0144	32.7108	-1.41	1.33
28.4	-2	35.6202	33.3552	31.2062	-1.38	1.31
30.2	-1	33.8936	31.7844	29.7796	-1.36	1.29
32	0	32.2608	30.2968	28.4267	-1.34	1.28
33.8	1	30.7162	28.8875	27.1431	-1.32	1.26
35.6	2	29.2545	27.5519	25.925	-1.29	1.24
37.4	3	27.8708	26.2858	24.7686	-1.27	1.22
39.2	4	26.5605	25.0851	23.6704	-1.25	1.2
41	5	25.3193	23.9462	22.6273	-1.23	1.18
42.8	6	24.1432	22.8656	21.6361	-1.2	1.16
44.6	7	23.0284	21.8398	20.6939	-1.18	1.14
46.4	8	21.9714	20.8659	19.7982	-1.15	1.12
48.2	9	20.9688	19.9409	18.9463	-1.13	1.09
50	10	20.0176	19.0621	18.1358	-1.11	1.07
51.8	11	19.1149	18.227	17.3646	-1.08	1.05
53.6	12	18.258	17.4331	16.6305	-1.06	1.03
55.4	13	17.4442	16.6782	15.9315	-1.03	1.01
57.2	14	16.6711	15.9601	15.2657	-1.01	0.99
59	15	15.9366	15.277	14.6315	-0.98	0.96
60.8	16	15.2385	14.6268	14.0271	-0.96	0.94

## Room and Pipe Sensor Tables

Temp. °F	Temp. °C	Max.(KΩ)	Normal(KΩ)	Min.(KΩ)	Tolerance (°C)	
62.6	17	14.5748	14.0079	13.451	-0.93	0.92
64.4	18	13.9436	13.4185	12.9017	-0.91	0.9
66.2	19	13.3431	12.8572	12.3778	-0.88	0.87
68	20	12.7718	12.3223	11.878	-0.86	0.85
69.8	21	12.228	11.8126	11.4011	-0.83	0.83
71.6	22	11.7102	11.3267	10.9459	-0.81	0.8
73.4	23	11.2172	10.8634	10.5114	-0.78	0.78
75.2	24	10.7475	10.4216	10.0964	-0.75	0.75
77	25	10.3	10	9.7	-0.75	0.75
78.8	26	9.8975	9.5974	9.298	-0.76	0.76
80.6	27	9.5129	9.2132	8.9148	-0.8	0.8
82.4	28	9.1454	8.8465	8.5496	-0.84	0.83
84.2	29	8.7942	8.4964	8.2013	-0.87	0.86
86	30	8.4583	8.1621	7.8691	-0.91	0.9
87.8	31	8.1371	7.8428	7.5522	-0.95	0.93
89.6	32	7.8299	7.5377	7.2498	-0.98	0.97
91.4	33	7.5359	7.2461	6.9611	-1.02	1
93.2	34	7.2546	6.9673	6.6854	-1.06	1.04
95	35	6.9852	6.7008	6.4222	-1.1	1.07
96.8	36	6.7273	6.4459	6.1707	-1.13	1.11
98.6	37	6.4803	6.2021	5.9304	-1.17	1.14
100.4	38	6.2437	5.9687	5.7007	-1.21	1.18
102.2	39	6.017	5.7454	5.4812	-1.25	1.22
104	40	5.7997	5.5316	5.2712	-1.29	1.25
105.8	41	5.5914	5.3269	5.0704	-1.33	1.29
107.6	42	5.3916	5.1308	4.8783	-1.37	1.33
109.4	43	5.2001	4.943	4.6944	-1.41	1.36
111.2	44	5.0163	4.763	4.5185	-1.45	1.4
113	45	4.84	4.5905	4.35	-1.49	1.44
114.8	46	4.6708	4.4252	4.1887	-1.53	1.47
116.6	47	4.5083	4.2666	4.0342	-1.57	1.51
118.4	48	4.3524	4.1145	3.8862	-1.61	1.55
120.2	49	4.2026	3.9686	3.7443	-1.65	1.59
122	50	4.0588	3.8287	3.6084	-1.7	1.62
123.8	51	3.9206	3.6943	3.478	-1.74	1.66
125.6	52	3.7878	3.5654	3.3531	-1.78	1.7
127.4	53	3.6601	3.4416	3.2332	-1.82	1.74
129.2	54	3.5374	3.3227	3.1183	-1.87	1.78
131	55	3.4195	3.2085	3.0079	-1.91	1.82
132.8	56	3.306	3.0989	2.9021	-1.95	1.85
134.6	57	3.1969	2.9935	2.8005	-2	1.89
136.4	58	3.0919	2.8922	2.7029	-2.04	1.93
138.2	59	2.9909	2.7948	2.6092	-2.08	1.97
140	60	2.8936	2.7012	2.5193	-2.13	2.01
141.8	61	2.8	2.6112	2.4328	-2.17	2.05
143.6	62	2.7099	2.5246	2.3498	-2.22	2.09
145.4	63	2.6232	2.4413	2.27	-2.26	2.13
147.2	64	2.5396	2.3611	2.1932	-2.31	2.17



## Room and Pipe Sensor Tables

Temp. °F	Temp. °C	Max.(KΩ)	Normal(KΩ)	Min.(KΩ)	Tolerance (°C)	
149	65	2.4591	2.284	2.1195	-2.36	2.21
150.8	66	2.3815	2.2098	2.0486	-2.4	2.25
152.6	67	2.3068	2.1383	1.9803	-2.45	2.29
154.4	68	2.2347	2.0695	1.9147	-2.49	2.34
156.2	69	2.1652	2.0032	1.8516	-2.54	2.38
158	70	2.0983	1.9393	1.7908	-2.59	2.42
159.8	71	2.0337	1.8778	1.7324	-2.63	2.46
161.6	72	1.9714	1.8186	1.6761	-2.68	2.5
163.4	73	1.9113	1.7614	1.6219	-2.73	2.54
165.2	74	1.8533	1.7064	1.5697	-2.78	2.58
167	75	1.7974	1.6533	1.5194	-2.83	2.63
168.8	76	1.7434	1.6021	1.471	-2.88	2.67
170.6	77	1.6913	1.5528	1.4243	-2.92	2.71
172.4	78	1.6409	1.5051	1.3794	-2.97	2.75
174.2	79	1.5923	1.4592	1.336	-3.02	2.8
176	80	1.5454	1.4149	1.2942	-3.07	2.84
177.8	81	1.5	1.3721	1.254	-3.12	2.88
179.6	82	1.4562	1.3308	1.2151	-3.17	2.93
181.4	83	1.4139	1.291	1.1776	-3.22	2.97
183.2	84	1.373	1.2525	1.1415	-3.27	3.01
185	85	1.3335	1.2153	1.1066	-3.32	3.06
186.8	86	1.2953	1.1794	1.073	-3.38	3.1
188.6	87	1.2583	1.1448	1.0405	-3.43	3.15
190.4	88	1.2226	1.1113	1.0092	-3.48	3.19
192.2	89	1.188	1.0789	0.9789	-3.53	3.24
194	90	1.1546	1.0476	0.9497	-3.58	3.28
195.8	91	1.1223	1.0174	0.9215	-3.64	3.33
197.6	92	1.091	0.9882	0.8942	-3.69	3.37
199.4	93	1.0607	0.9599	0.8679	-3.74	3.42
201.2	94	1.0314	0.9326	0.8424	-3.8	3.46
203	95	1.003	0.9061	0.8179	-3.85	3.51
204.8	96	0.9756	0.8806	0.7941	-3.9	3.55
206.6	97	0.949	0.8558	0.7711	-3.96	3.6
208.4	98	0.9232	0.8319	0.7489	-4.01	3.64
210.2	99	0.8983	0.8088	0.7275	-4.07	3.69
212	100	0.8741	0.7863	0.7067	-4.12	3.74
213.8	101	0.8507	0.7646	0.6867	-4.18	3.78
215.6	102	0.8281	0.7436	0.6672	-4.23	3.83
217.4	103	0.8061	0.7233	0.6484	-4.29	3.88
219.2	104	0.7848	0.7036	0.6303	-4.34	3.92
221	105	0.7641	0.6845	0.6127	-4.4	3.97
222.8	106	0.7441	0.6661	0.5957	-4.46	4.02
224.6	107	0.7247	0.6482	0.5792	-4.51	4.07
226.4	108	0.7059	0.6308	0.5632	-4.57	4.12
228.2	109	0.6877	0.614	0.5478	-4.63	4.16
230	110	0.67	0.5977	0.5328	-4.69	4.21
231.8	111	0.6528	0.582	0.5183	-4.74	4.26
233.6	112	0.6361	0.5667	0.5043	-4.8	4.31

## Room and Pipe Sensor Tables

Temp. °F	Temp. °C	Max.(KΩ)	Normal(KΩ)	Min.(KΩ)	Tolerance (°C)	
235.4	113	0.62	0.5518	0.4907	-4.86	4.36
237.2	114	0.6043	0.5374	0.4775	-4.92	4.41
239	115	0.5891	0.5235	0.4648	-4.98	4.45
240.8	116	0.5743	0.51	0.4524	-5.04	4.5
242.6	117	0.56	0.4968	0.4404	-5.1	4.55
244.4	118	0.546	0.4841	0.4288	-5.16	4.6
246.2	119	0.5325	0.4717	0.4175	-5.22	4.65
248	120	0.5194	0.4597	0.4066	-5.28	4.7

## Ambient, Defrosting, Pipe Sensor Tables

Temp. °F	Temp. °C	Max.(KΩ)	Normal(KΩ)	Min.(KΩ)	Tolerance (°C)	
-22	-30	165.2170	147.9497	132.3678	-1.94	1.75
-20	-29	155.5754	139.5600	125.0806	-1.93	1.74
-18	-28	146.5609	131.7022	118.2434	-1.91	1.73
-17	-27	138.1285	124.3392	111.8256	-1.89	1.71
-15	-26	130.2371	117.4366	105.7989	-1.87	1.70
-13	-25	122.8484	110.9627	100.1367	-1.85	1.69
-11	-24	115.9272	104.8882	94.8149	-1.83	1.67
-9	-23	109.4410	99.1858	89.8106	-1.81	1.66
-8	-22	103.3598	93.8305	85.1031	-1.80	1.64
-6	-21	97.6556	88.7989	80.6728	-1.78	1.63
-4	-20	92.3028	84.0695	76.5017	-1.76	1.62
-2	-19	87.2775	79.6222	72.5729	-1.74	1.60
0	-18	82.5577	75.4384	68.8710	-1.72	1.59
1	-17	78.1230	71.5010	65.3815	-1.70	1.57
3	-16	73.9543	67.7939	62.0907	-1.68	1.55
5	-15	70.0342	64.3023	58.9863	-1.66	1.54
7	-14	66.3463	61.0123	56.0565	-1.64	1.52
9	-13	62.8755	57.9110	53.2905	-1.62	1.51
10	-12	59.6076	54.9866	50.6781	-1.60	1.49
12	-11	56.5296	52.2278	48.2099	-1.58	1.47
14	-10	53.6294	49.6244	45.8771	-1.56	1.46
16	-9	50.8956	47.1666	43.6714	-1.54	1.44
18	-8	48.3178	44.8454	41.5851	-1.51	1.42
19	-7	45.8860	42.6525	39.6112	-1.49	1.40
21	-6	43.5912	40.5800	37.7429	-1.47	1.39
23	-5	41.4249	38.6207	35.9739	-1.45	1.37
25	-4	39.3792	36.7676	34.2983	-1.43	1.35
27	-3	37.4465	35.0144	32.7108	-1.41	1.33
28	-2	35.6202	33.3552	31.2062	-1.38	1.31
30	-1	33.8936	31.7844	29.7796	-1.36	1.29
32	0	32.2608	30.2968	28.4267	-1.34	1.28
34	1	30.7162	28.8875	27.1431	-1.32	1.26
36	2	29.2545	27.5519	25.9250	-1.29	1.24
37	3	27.8708	26.2858	24.7686	-1.27	1.22
39	4	26.5605	25.0851	23.6704	-1.25	1.20
41	5	25.3193	23.9462	22.6273	-1.23	1.18
43	6	24.1432	22.8656	21.6361	-1.20	1.16

## Ambient, Defrosting, Pipe Sensor Tables

Temp. °F	Temp. °C	Max.(KΩ)	Normal(KΩ)	Min.(KΩ)	Tolerance (°C)	
45	7	23.0284	21.8398	20.6939	-1.18	1.14
46	8	21.9714	20.8659	19.7982	-1.15	1.12
48	9	20.9688	19.9409	18.9463	-1.13	1.09
50	10	20.0176	19.0621	18.1358	-1.11	1.07
52	11	19.1149	18.2270	17.3646	-1.08	1.05
54	12	18.2580	17.4331	16.6305	-1.06	1.03
55	13	17.4442	16.6782	15.9315	-1.03	1.01
57	14	16.6711	15.9601	15.2657	-1.01	0.99
59	15	15.9366	15.2770	14.6315	-0.98	0.96
61	16	15.2385	14.6268	14.0271	-0.96	0.94
63	17	14.5748	14.0079	13.4510	-0.93	0.92
64	18	13.9436	13.4185	12.9017	-0.91	0.90
66	19	13.3431	12.8572	12.3778	-0.88	0.87
68	20	12.7718	12.3223	11.8780	-0.86	0.85
70	21	12.2280	11.8126	11.4011	-0.83	0.83
72	22	11.7102	11.3267	10.9459	-0.81	0.80
73	23	11.2172	10.8634	10.5114	-0.78	0.78
75	24	10.7475	10.4216	10.0964	-0.75	0.75
77	25	10.3000	10.0000	9.7000	-0.75	0.75
79	26	9.8975	9.5974	9.2980	-0.76	0.76
81	27	9.5129	9.2132	8.9148	-0.80	0.80
82	28	9.1454	8.8465	8.5496	-0.84	0.83
84	29	8.7942	8.4964	8.2013	-0.87	0.86
86	30	8.4583	8.1621	7.8691	-0.91	0.90
88	31	8.1371	7.8428	7.5522	-0.95	0.93
90	32	7.8299	7.5377	7.2498	-0.98	0.97
91	33	7.5359	7.2461	6.9611	-1.02	1.00
93	34	7.2546	6.9673	6.6854	-1.06	1.04
95	35	6.9852	6.7008	6.4222	-1.10	1.07
97	36	6.7273	6.4459	6.1707	-1.13	1.11
99	37	6.4803	6.2021	5.9304	-1.17	1.14
100	38	6.2437	5.9687	5.7007	-1.21	1.18
102	39	6.0170	5.7454	5.4812	-1.25	1.22
104	40	5.7997	5.5316	5.2712	-1.29	1.25
106	41	5.5914	5.3269	5.0704	-1.33	1.29
108	42	5.3916	5.1308	4.8783	-1.37	1.33
109	43	5.2001	4.9430	4.6944	-1.41	1.36
111	44	5.0163	4.7630	4.5185	-1.45	1.40
113	45	4.8400	4.5905	4.3500	-1.49	1.44
115	46	4.6708	4.4252	4.1887	-1.53	1.47
117	47	4.5083	4.2666	4.0342	-1.57	1.51
118	48	4.3524	4.1145	3.8862	-1.61	1.55
120	49	4.2026	3.9686	3.7443	-1.65	1.59
122	50	4.0588	3.8287	3.6084	-1.70	1.62
124	51	3.9206	3.6943	3.4780	-1.74	1.66
126	52	3.7878	3.5654	3.3531	-1.78	1.70
127	53	3.6601	3.4416	3.2332	-1.82	1.74
129	54	3.5374	3.3227	3.1183	-1.87	1.78

## Ambient, Defrosting, Pipe Sensor Tables

ENGLISH

Temp. °F	Temp. °C	Max.(KΩ)	Normal(KΩ)	Min.(KΩ)	Tolerance (°C)	
131	55	3.4195	3.2085	3.0079	-1.91	1.82
133	56	3.3060	3.0989	2.9021	-1.95	1.85
135	57	3.1969	2.9935	2.8005	-2.00	1.89
136	58	3.0919	2.8922	2.7029	-2.04	1.93
138	59	2.9909	2.7948	2.6092	-2.08	1.97
140	60	2.8936	2.7012	2.5193	-2.13	2.01
142	61	2.8000	2.6112	2.4328	-2.17	2.05
144	62	2.7099	2.5246	2.3498	-2.22	2.09
145	63	2.6232	2.4413	2.2700	-2.26	2.13
147	64	2.5396	2.3611	2.1932	-2.31	2.17
149	65	2.4591	2.2840	2.1195	-2.36	2.21
151	66	2.3815	2.2098	2.0486	-2.40	2.25
153	67	2.3068	2.1383	1.9803	-2.45	2.29
154	68	2.2347	2.0695	1.9147	-2.49	2.34
156	69	2.1652	2.0032	1.8516	-2.54	2.38
158	70	2.0983	1.9393	1.7908	-2.59	2.42
160	71	2.0337	1.8778	1.7324	-2.63	2.46
162	72	1.9714	1.8186	1.6761	-2.68	2.50
163	73	1.9113	1.7614	1.6219	-2.73	2.54
165	74	1.8533	1.7064	1.5697	-2.78	2.58
167	75	1.7974	1.6533	1.5194	-2.83	2.63
169	76	1.7434	1.6021	1.4710	-2.88	2.67
171	77	1.6913	1.5528	1.4243	-2.92	2.71
172	78	1.6409	1.5051	1.3794	-2.97	2.75
174	79	1.5923	1.4592	1.3360	-3.02	2.80
176	80	1.5454	1.4149	1.2942	-3.07	2.84
178	81	1.5000	1.3721	1.2540	-3.12	2.88
180	82	1.4562	1.3308	1.2151	-3.17	2.93
181	83	1.4139	1.2910	1.1776	-3.22	2.97
183	84	1.3730	1.2525	1.1415	-3.27	3.01
185	85	1.3335	1.2153	1.1066	-3.32	3.06
187	86	1.2953	1.1794	1.0730	-3.38	3.10
189	87	1.2583	1.1448	1.0405	-3.43	3.15
190	88	1.2226	1.1113	1.0092	-3.48	3.19
192	89	1.1880	1.0789	0.9789	-3.53	3.24
194	90	1.1546	1.0476	0.9497	-3.58	3.28
196	91	1.1223	1.0174	0.9215	-3.64	3.33
198	92	1.0910	0.9882	0.8942	-3.69	3.37
199	93	1.0607	0.9599	0.8679	-3.74	3.42
201	94	1.0314	0.9326	0.8424	-3.80	3.46
203	95	1.0030	0.9061	0.8179	-3.85	3.51
205	96	0.9756	0.8806	0.7941	-3.90	3.55
207	97	0.9490	0.8558	0.7711	-3.96	3.60
208	98	0.9232	0.8319	0.7489	-4.01	3.64
210	99	0.8983	0.8088	0.7275	-4.07	3.69
212	100	0.8741	0.7863	0.7067	-4.12	3.74
214	101	0.8507	0.7646	0.6867	-4.18	3.78
216	102	0.8281	0.7436	0.6672	-4.23	3.83

## Ambient, Defrosting, Pipe Sensor Tables

Temp. °F	Temp. °C	Max.(KΩ)	Normal(KΩ)	Min.(KΩ)	Tolerance (°C)	
217	103	0.8061	0.7233	0.6484	-4.29	3.88
219	104	0.7848	0.7036	0.6303	-4.34	3.92
221	105	0.7641	0.6845	0.6127	-4.40	3.97
223	106	0.7441	0.6661	0.5957	-4.46	4.02
225	107	0.7247	0.6482	0.5792	-4.51	4.07
226	108	0.7059	0.6308	0.5632	-4.57	4.12
228	109	0.6877	0.6140	0.5478	-4.63	4.16
230	110	0.6700	0.5977	0.5328	-4.69	4.21
232	111	0.6528	0.5820	0.5183	-4.74	4.26
234	112	0.6361	0.5667	0.5043	-4.80	4.31
235	113	0.6200	0.5518	0.4907	-4.86	4.36
237	114	0.6043	0.5374	0.4775	-4.92	4.41
239	115	0.5891	0.5235	0.4648	-4.98	4.45
241	116	0.5743	0.5100	0.4524	-5.04	4.50
243	117	0.5600	0.4968	0.4404	-5.10	4.55
244	118	0.5460	0.4841	0.4288	-5.16	4.60
246	119	0.5325	0.4717	0.4175	-5.22	4.65
248	120	0.5194	0.4597	0.4066	-5.28	4.70

## Discharging Sensor Tables

**R176° = 50KΩ±3%**

**B77°/176° = 4450K±3%**

Temp.(°F)	Temp.(°C)	Max.(KΩ)	Normal(KΩ)	Min.(KΩ)	Tolerance	
-22	-30	14646.0505	12061.7438	9924.4999	-2.96	2.45
-20.2	-29	13654.1707	11267.873	9290.2526	-2.95	2.44
-18.4	-28	12735.8378	10531.3695	8700.6388	-2.93	2.44
-16.6	-27	11885.1336	9847.724	8152.2338	-2.92	2.43
-14.8	-26	11096.6531	9212.8101	7641.8972	-2.91	2.42
-13	-25	10365.4565	8622.8491	7166.7474	-2.9	2.42
-11.2	-24	9687.027	8074.3787	6724.1389	-2.88	2.41
-9.4	-23	9057.2314	7564.2244	6311.6413	-2.87	2.41
-7.6	-22	8472.2852	7089.4741	5927.0206	-2.86	2.4
-5.8	-21	7928.7217	6647.4547	5568.2222	-2.84	2.39
-4	-20	7423.3626	6235.7109	5233.3554	-2.83	2.39
-2.2	-19	6953.293	5851.9864	4920.6791	-2.82	2.38
-0.4	-18	6515.8375	5494.2064	4628.5894	-2.8	2.37
1.4	-17	6108.5393	5160.4621	4355.6078	-2.79	2.37
3.2	-16	5729.1413	4848.9963	4100.3708	-2.77	2.36
5	-15	5375.5683	4558.1906	3861.6201	-2.76	2.35
6.8	-14	5045.9114	4286.5535	3638.1938	-2.75	2.34
8.6	-13	4738.4141	4032.7098	3429.0191	-2.73	2.34
10.4	-12	4451.4586	3795.391	3233.1039	-2.72	2.33
12.2	-11	4183.5548	3573.426	3049.5312	-2.7	2.32
14	-10	3933.3289	3365.7336	2877.4527	-2.69	2.31
15.8	-9	3699.5139	3171.3148	2716.0828	-2.67	2.3
17.6	-8	3480.9407	2989.246	2564.6945	-2.66	2.29
19.4	-7	3276.5302	2818.6731	2422.6139	-2.64	2.28
21.2	-6	3085.2854	2658.8058	2289.2164	-2.63	2.28
23	-5	2906.2851	2508.9126	2163.923	-2.61	2.27

## Discharging Sensor Tables

Temp.(°F)	Temp.(°C)	Max.(KΩ)	Normal(KΩ)	Min.(KΩ)	Tolerance	
24.8	-4	2738.6777	2368.3158	2046.1961	-2.6	2.26
26.6	-3	2581.6752	2236.3876	1935.5371	-2.58	2.25
28.4	-2	2434.5487	2112.5459	1831.4826	-2.56	2.24
30.2	-1	2296.623	1996.2509	1733.6024	-2.55	2.23
32	0	2167.273	1887.0018	1641.4966	-2.53	2.22
33.8	1	2045.9191	1784.3336	1554.7931	-2.52	2.21
35.6	2	1932.0242	1687.8144	1473.146	-2.5	2.2
37.4	3	1825.0899	1597.0431	1396.2333	-2.48	2.19
39.2	4	1724.654	1511.6468	1323.7551	-2.47	2.17
41	5	1630.287	1431.2787	1255.4324	-2.45	2.16
42.8	6	1541.5904	1355.6163	1191.0048	-2.43	2.15
44.6	7	1458.1938	1284.3593	1130.2298	-2.41	2.14
46.4	8	1379.7528	1217.2282	1072.8813	-2.4	2.13
48.2	9	1305.9472	1153.9626	1018.7481	-2.38	2.12
50	10	1236.4792	1094.32	967.6334	-2.36	2.11
51.8	11	1171.0715	1038.0743	919.3533	-2.35	2.09
53.6	12	1109.4661	985.0146	873.7359	-2.33	2.08
55.4	13	1051.4226	934.944	830.621	-2.31	2.07
57.2	14	996.7169	887.6792	789.8583	-2.29	2.06
59	15	945.1404	843.0486	751.3077	-2.27	2.04
60.8	16	896.4981	800.8922	714.838	-2.26	2.03
62.6	17	850.6086	761.0603	680.3265	-2.24	2.02
64.4	18	807.3024	723.4134	647.658	-2.22	2
66.2	19	766.4212	687.8205	616.7252	-2.2	1.99
68	20	727.8172	654.1596	587.4271	-2.18	1.98
69.8	21	691.3524	622.3161	559.6694	-2.16	1.96
71.6	22	656.8979	592.1831	533.3634	-2.14	1.95
73.4	23	624.3328	563.6604	508.4261	-2.12	1.93
75.2	24	593.5446	536.654	484.7796	-2.1	1.92
77	25	564.4275	511.076	462.351	-2.09	1.9
78.8	26	536.9865	486.9352	441.1516	-2.07	1.89
80.6	27	511.0105	464.05	421.0258	-2.05	1.87
82.4	28	486.4151	442.3499	401.9146	-2.03	1.86
84.2	29	463.1208	421.7683	383.7626	-2.01	1.84
86	30	441.0535	402.243	366.5175	-1.99	1.83
87.8	31	420.1431	383.7151	350.1301	-1.97	1.81
89.6	32	400.3242	366.1295	334.5542	-1.95	1.8
91.4	33	381.535	349.4341	319.746	-1.93	1.78
93.2	34	363.7176	333.5801	305.6645	-1.9	1.76
95	35	346.8176	318.5216	292.2709	-1.88	1.75
96.8	36	330.7839	304.2151	279.5286	-1.86	1.73
98.6	37	315.5682	290.6199	267.4031	-1.84	1.71
100.4	38	301.1254	277.6976	255.862	-1.82	1.7
102.2	39	287.4128	265.4119	244.8745	-1.8	1.68
104	40	274.3905	253.7288	234.4118	-1.78	1.66
105.8	41	262.0206	242.6161	224.4465	-1.76	1.64
107.6	42	250.2676	232.0436	214.9529	-1.74	1.63
109.4	43	239.0983	221.9825	205.9065	-1.71	1.61
111.2	44	228.4809	212.406	197.2844	-1.69	1.59

## Discharging Sensor Tables

Temp.(°F)	Temp.(°C)	Max.(KΩ)	Normal(KΩ)	Min.(KΩ)	Tolerance	
113	45	218.386	203.2887	189.0648	-1.67	1.57
114.8	46	208.7855	194.6066	181.2273	-1.65	1.55
116.6	47	199.6531	186.3369	173.7524	-1.63	1.54
118.4	48	190.9639	178.4584	166.6217	-1.6	1.52
120.2	49	182.6945	170.9508	159.8181	-1.58	1.5
122	50	174.8228	163.7951	153.3249	-1.56	1.48
123.8	51	167.328	156.9733	147.1268	-1.53	1.46
125.6	52	160.1904	150.4683	141.209	-1.51	1.44
127.4	53	153.3914	144.2641	135.5577	-1.49	1.42
129.2	54	146.9136	138.3454	130.1598	-1.47	1.4
131	55	140.7403	132.698	125.0027	-1.44	1.38
132.8	56	134.8559	127.3081	120.0746	-1.42	1.36
134.6	57	129.2457	122.163	115.3645	-1.4	1.34
136.4	58	123.8956	117.2504	110.8618	-1.37	1.32
138.2	59	118.7926	112.5589	106.5564	-1.35	1.3
140	60	113.9241	108.0776	102.4388	-1.32	1.28
141.8	61	109.2784	103.7961	98.5	-1.3	1.26
143.6	62	104.8443	99.7046	94.7315	-1.28	1.23
145.4	63	100.6112	95.7939	91.1253	-1.25	1.21
147.2	64	96.5692	92.0553	87.6735	-1.23	1.19
149	65	92.7088	88.4805	84.369	-1.2	1.17
150.8	66	89.0211	85.0614	81.2048	-1.18	1.15
152.6	67	85.4976	81.7908	78.1744	-1.15	1.12
154.4	68	82.1303	78.6615	75.2715	-1.13	1.1
156.2	69	78.9116	75.6668	72.4902	-1.1	1.08
158	70	75.8343	72.8004	69.8249	-1.08	1.06
159.8	71	72.8916	70.0561	67.2703	-1.05	1.03
161.6	72	70.077	67.4283	64.8213	-1.03	1.01
163.4	73	67.3844	64.9115	62.4731	-1	0.99
165.2	74	64.808	62.5006	60.2211	-0.98	0.96
167	75	62.3423	60.1906	58.0609	-0.95	0.94
168.8	76	59.9821	57.977	55.9885	-0.92	0.92
170.6	77	57.7223	55.8552	53.9998	-0.9	0.89
172.4	78	55.5583	53.821	52.0912	-0.87	0.87
174.2	79	53.4856	51.8706	50.2591	-0.85	0.84
176	80	51.5	50	48.5	-0.85	0.84
177.8	81	49.7063	48.2057	46.7083	-0.85	0.85
179.6	82	47.9835	46.4842	44.9911	-0.89	0.89
181.4	83	46.3286	44.8323	43.3452	-0.93	0.92
183.2	84	44.7385	43.2468	41.7672	-0.96	0.95
185	85	43.2105	41.7248	40.254	-1	0.99
186.8	86	41.7386	40.2604	38.7996	-1.03	1.02
188.6	87	40.3241	38.8545	37.4048	-1.07	1.06
190.4	88	38.9643	37.5045	36.0668	-1.11	1.09
192.2	89	37.6569	36.2078	34.7831	-1.14	1.13
194	90	36.3996	34.9622	33.5513	-1.18	1.16
195.8	91	35.1903	33.7653	32.3689	-1.22	1.19
197.6	92	34.0269	32.6151	31.2338	-1.26	1.23
199.4	93	32.9075	31.5096	30.1438	-1.3	1.27

## Discharging Sensor Tables

Temp.(°F)	Temp.(°C)	Max.(KΩ)	Normal(KΩ)	Min.(KΩ)	Tolerance	
201.2	94	31.8302	30.4467	29.097	-1.33	1.3
203	95	30.7933	29.4246	28.0915	-1.37	1.34
204.8	96	29.795	28.4417	27.1254	-1.41	1.37
206.6	97	28.8337	27.4961	26.197	-1.45	1.41
208.4	98	27.9078	26.5864	25.3048	-1.49	1.44
210.2	99	27.016	25.711	24.447	-1.53	1.48
212	100	26.1569	24.8685	23.6222	-1.57	1.52
213.8	101	25.329	24.0574	22.8291	-1.61	1.55
215.6	102	24.5311	23.2765	22.0662	-1.65	1.59
217.4	103	23.762	22.5245	21.3323	-1.69	1.63
219.2	104	23.0205	21.8002	20.6261	-1.73	1.66
221	105	22.3055	21.1025	19.9465	-1.77	1.7
222.8	106	21.6159	20.4303	19.2924	-1.81	1.74
224.6	107	20.9508	19.7825	18.6626	-1.85	1.77
226.4	108	20.3091	19.1582	18.0563	-1.89	1.81
228.2	109	19.6899	18.5564	17.4723	-1.93	1.85
230	110	19.0924	17.9761	16.9098	-1.98	1.89
231.8	111	18.5157	17.4166	16.368	-2.02	1.93
233.6	112	17.959	16.8769	15.8458	-2.06	1.96
235.4	113	17.4214	16.3564	15.3427	-2.1	2
237.2	114	16.9023	15.8542	14.8577	-2.15	2.04
239	115	16.401	15.3696	14.3902	-2.19	2.08
240.8	116	15.9167	14.902	13.9394	-2.23	2.12
242.6	117	15.4489	14.4506	13.5047	-2.27	2.16
244.4	118	14.9968	14.0149	13.0855	-2.32	2.19
246.2	119	14.5599	13.5942	12.6811	-2.36	2.23
248	120	14.1376	13.1879	12.2909	-2.41	2.27
249.8	121	13.7294	12.7955	11.9144	-2.45	2.31
251.6	122	13.3347	12.4165	11.551	-2.5	2.35
253.4	123	12.9531	12.0503	11.2003	-2.54	2.39
255.2	124	12.584	11.6965	10.8617	-2.58	2.43
257	125	12.227	11.3545	10.5348	-2.63	2.47
258.8	126	11.8817	11.024	10.2191	-2.68	2.51
260.6	127	11.5475	10.7046	9.9142	-2.72	2.55
262.4	128	11.2242	10.3957	9.6197	-2.77	2.59
264.2	129	10.9112	10.097	9.3352	-2.81	2.63
266	130	10.6084	9.8082	9.0602	-2.86	2.67
267.8	131	10.3151	9.5288	8.7945	-2.91	2.71
269.6	132	10.0312	9.2586	8.5378	-2.95	2.75
271.4	133	9.7563	8.9971	8.2895	-3	2.8
273.2	134	9.4901	8.7441	8.0495	-3.05	2.84
275	135	9.2322	8.4993	7.8175	-3.09	2.88
276.8	136	8.9824	8.2623	7.5931	-3.14	2.92
278.6	137	8.7404	8.0329	7.376	-3.19	2.96
280.4	138	8.5059	7.8108	7.166	-3.24	3
282.2	139	8.2787	7.5958	6.9629	-3.29	3.04
284	140	8.0584	7.3875	6.7664	-3.33	3.09





[www.Haier.com](http://www.Haier.com)

Model #: AW09ES2VHA, 1U09ES2VHA

AW12ES2VHA, 1U12ES2VHA

AW18ES2VHA, 1U18ES2VHA

AW24ES2VHA, 1U24ES2VHA

Issued Date: November 2015

Haier America,  
Wayne, NJ 07470

©2015 Haier America Trading, LLC.