

Panasonic®

Operating Instructions DVD Video Camera

Model No. **VDR-D50**

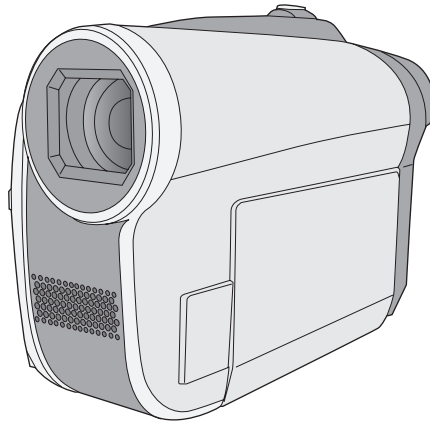

Before use, please read these instructions completely.



Information for Your Safety

WARNING:

TO REDUCE THE RISK OF FIRE, ELECTRIC SHOCK OR PRODUCT DAMAGE,

- DO NOT EXPOSE THIS APPARATUS TO RAIN, MOISTURE, DRIPPING OR SPLASHING AND THAT NO OBJECTS FILLED WITH LIQUIDS, SUCH AS VASES, SHALL BE PLACED ON THE APPARATUS.
- USE ONLY THE RECOMMENDED ACCESSORIES.
- DO NOT REMOVE THE COVER (OR BACK); THERE ARE NO USER SERVICEABLE PARTS INSIDE. REFER SERVICING TO QUALIFIED SERVICE PERSONNEL.

CAUTION!

- DO NOT INSTALL OR PLACE THIS UNIT IN A BOOKCASE, BUILT-IN CABINET OR IN ANOTHER CONFINED SPACE. ENSURE THE UNIT IS WELL VENTILATED. TO PREVENT RISK OF ELECTRIC SHOCK OR FIRE HAZARD DUE TO OVERHEATING, ENSURE THAT CURTAINS AND ANY OTHER MATERIALS DO NOT OBSTRUCT THE VENTILATION VENTS.
- DO NOT OBSTRUCT THE UNIT'S VENTILATION OPENINGS WITH NEWSPAPERS, TABLECLOTHS, CURTAINS, AND SIMILAR ITEMS.
- DO NOT PLACE SOURCES OF NAKED FLAMES, SUCH AS LIGHTED CANDLES, ON THE UNIT.
- DISPOSE OF BATTERIES IN AN ENVIRONMENTALLY FRIENDLY MANNER.

The socket outlet shall be installed near the equipment and easily accessible. The mains plug of the power supply cord shall remain readily operable. To completely disconnect this apparatus from the AC Mains, disconnect the power supply cord plug from AC receptacle.

Product Identification Marking is located on the bottom of units.

IF THE POWER CORD OF THIS EQUIPMENT IS DAMAGED, IT MUST BE REPLACED WITH AN ELECTRICALLY APPROVED POWER CORD.

Use only the recommended accessories.

- Do not use any other AV cables and USB cables except the supplied one.
- When you use the cable which are sold separately, please make sure to use the one whose length is less than 3 meters.

**CLASS 1
LASER PRODUCT**

IEC60825-1:2001

CAUTION

This product contains a laser diode of higher class than 1.

To ensure continued safety, do not remove any covers or attempt to gain access to the inside of the product. Refer all servicing to qualified personnel.

-If you see this symbol-

Information on Disposal in other Countries outside the European Union



This symbol is only valid in the European Union.

If you wish to discard this product, please contact your local authorities or dealer and ask for the correct method of disposal.

■ **Indemnity concerning recording content**

The manufacturer shall in no event be liable for the loss of recordings due to malfunction or defect of this unit, its accessories or recordable media.

■ **Carefully observe copyright laws**

Recording of pre-recorded tapes or discs or other published or broadcast material for purposes other than your own private use may infringe copyright laws. Even for the purpose of private use, recording of certain material may be restricted.

Contents

Features	7
Accessories.....	8

Preparation

Before using

1 Parts identification and handling	10
2 Power supply	14
Charging the battery	14
Inserting the battery	15
Charging time and recordable time	15
Connecting to the AC outlet.....	17
3 About discs	18
4 Inserting/removing a disc.....	21
5 About SD cards.....	22
6 Inserting/removing an SD card	23

Setup

1 Turning the unit on/off Selecting a mode	24
2 Using the menu screen	26
Language selection	27
Menu list	27
3 Setting date and time	29
4 Adjusting LCD monitor/ viewfinder.....	30

Recording

Recording (Basic)

1 Before recording.....	32
2 Recording motion pictures.....	33
Recording modes and recordable time	34
3 Recording still pictures on an SD card.....	35
Number of pixels and picture quality ...	36
4 Recording functions.....	37
Zoom in/out function.....	37
Recording yourself.....	38
Image stabilizer function.....	39

Recording (Advanced)

1 Recording functions of operation icons	40
Operation icons	41
Backlight compensation/Fade/ Help mode/Colour night view/ Soft skin mode/Self-timer	

2 Recording functions of menus	44
Menu	44
Guideline/Aspect ratio/ Wind noise reduction/ Auto slow shutter	
3 Manual recording functions	45
Scene mode	46
Manual focus adjustment	46
White balance	47
Manual shutter speed/ aperture adjustment	48

Playback

Playback

1 Motion picture playback.....	50
2 Still picture playback	53

Editing

1 Deleting scenes/files.....	55
Deleting scenes/files one at a time	55
Deleting multiple scenes/files	55
2 Editing scenes.....	57
3 Using playlists.....	59
Creating a new playlist.....	59
Editing a playlist	60
4 Editing still pictures.....	62

Disc and SD card management

1 Finalizing a disc	64
Un-finalizing a DVD-RW disc	65
2 Protecting a disc/ disc information	66
Protecting a disc.....	66
Displaying disc information	66
3 Formatting a disc/an SD card	67
Formatting a disc.....	67
Formatting an SD card	67

With other products

1 Playback on TV.....	68
2 With a DVD recorder/player.....	69
Playback on DVD recorder, DVD player, PC etc.	69
Dubbing recordings onto a DVD recorder's hard disk.....	69
3 Dubbing images onto a VCR.....	70
4 With a printer (PictBridge).....	71

With a PC

Before using

- 1** What you can do with a PC..... 74
- 2** Operating environment..... 75
 - End User License Agreement..... 77

Setup

- 1** Installation..... 78
 - Installing VideoCam Suite 78
 - Uninstalling the software 79
- 2** Connection and recognition..... 80
 - About the PC display 81
 - To disconnect USB cable safely 82

Using software

- 1** Starting VideoCam Suite..... 83
 - Reading the operating instructions
of the software 83

Using a Macintosh

- 1** If using a Macintosh..... 84

Others

Indications

- 1** Indications..... 86
- 2** Messages 88

Helpful hints

- 1** Functions that cannot be used
simultaneously90
- 2** Frequently asked questions 91
- 3** Troubleshooting 92

Cautions for use 97

Explanation of terms 100

Specifications 102

- Number of recordable pictures
on an SD card..... 104

Features

■ DVD-RW and DVD-R/DVD-R DL discs

Recordings made on DVD-RW or DVD-R/DVD-R DL discs cannot be played in other DVD devices or PCs unless the discs are finalized. (→ 64)

■ Using with DVD player/recorder (→ 69)

Just insert the disc into a DVD player/recorder compatible with 8 cm discs to play back the scenes recorded with this unit.

If you have a DVD recorder with hard disk, you can dub scenes recorded on a disc with this unit to the hard disk.

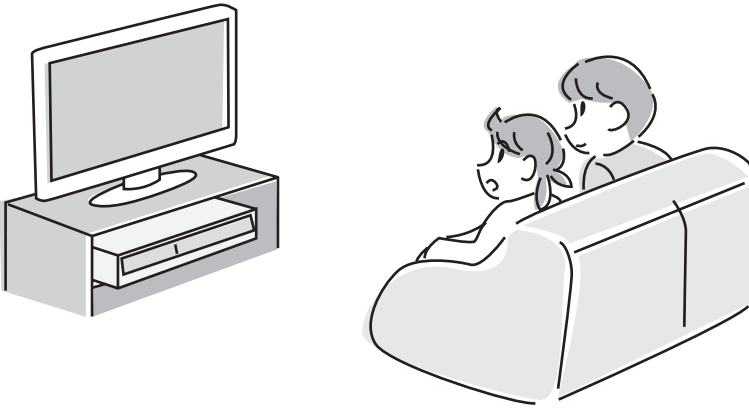

■ Using a PC to edit your recordings (→ 74)

You can edit scenes with the software on the supplied CD-ROM and create DVD-Video discs.



Accessories

Check the accessories before using this unit.

Battery pack



AC adaptor



DC cable



AV cable



AC cable



USB cable



CD-ROM



Optional accessories

Some optional accessories may not be available in some countries.

AC adaptor (VW-AD21GN-K)
Battery pack (lithium/VW-VBG130/1320 mAh)
Battery pack (lithium/VW-VBG260/2640 mAh)
Battery pack (lithium/VW-VBG6*/5800 mAh)
Video DC light (VW-LDC102E)
Light bulb for video DC light (VZ-LL10E)
Shoe adaptor (VW-SK12E)
Tripod (VW-CT45E)
Battery pack holder kit (VW-VH04)
8 cm DVD-RAM disc (single sided/LM-AF30E)
8 cm DVD-RAM disc (double sided/ LM-AF60E)
8 cm DVD-RW disc (single sided/LM-RW30E)
8 cm DVD-RW disc (double sided/ LM-RW60E)
8 cm DVD-R disc (single sided/LM-RF30E)
8 cm DVD-R disc (double sided/LM-RF60E)
8 cm DVD-R DL disc (dual layer on single side/LM-RF55LE)

* The battery pack holder kit VW-VH04 (optional) is necessary.

Preparation

Recording

Playback

With a PC

Others

10 Before using

24 Setup

Parts identification and handling

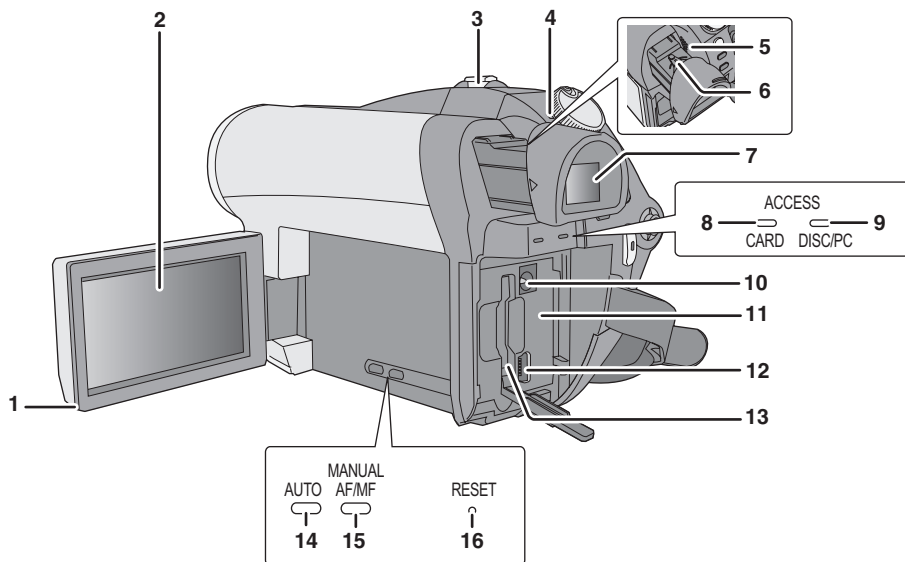

- 1 LCD monitor open part
- 2 LCD monitor

Due to limitations in LCD production technology, there may be some tiny bright or dark spots on the LCD monitor screen. However, this is not a malfunction and does not affect the recorded picture.

- 3 When recording: Zoom lever [W/T] (→ 37)
When playing back: Volume lever [-VOL+] (→ 51)
- 4 Status indicator (→ 24)
- 5 Speaker
- 6 Eyepiece corrector knob (→ 30)

LCD monitor

Pull the LCD monitor out in the direction of the arrow with your fingers.

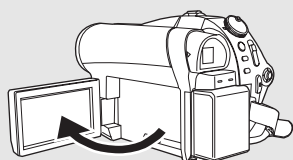

- It can open up to 90°.

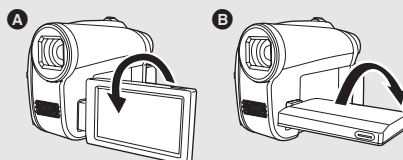

- It can rotate up to 180° **A** towards the lens or 90° **B** towards the viewfinder.

- The brightness and colour level of the LCD monitor can be adjusted. (→ 30)

7 Viewfinder

Due to limitations in LCD production technology, there may be some tiny bright or dark spots on the viewfinder screen. However, this is not a malfunction and does not affect the recorded picture.

- 8 SD card access lamp [ACCESS CARD] (→ 23)
- 9 Disc/PC access lamp [ACCESS DISC/PC] (→ 21, 80)
- 10 DC input terminal [DC/C.C.IN] (→ 17)
- 11 Battery holder (→ 15)
- 12 USB terminal [] (→ 71, 80)
- 13 SD card slot [SD CARD] (→ 23)
- 14 Auto button [AUTO] (→ 32)
- 15 Manual button [MANUAL AF/MF] (→ 45)
- 16 Reset button [RESET] (→ 95)

Viewfinder

Pull out the viewfinder.

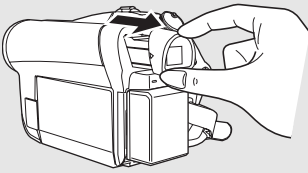

Close the LCD monitor when using the viewfinder.

- The brightness of the viewfinder and the field of view can be adjusted. (→ 30)

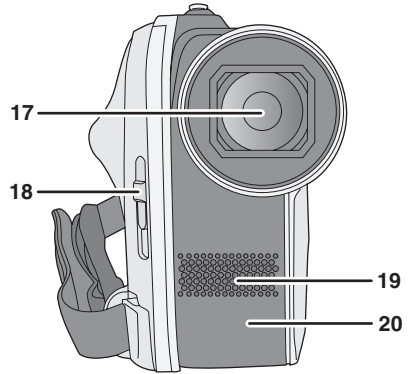

- 17 Lens
- 18 Lens cover open/close switch
- 19 Microphone (built-in, stereo)
- 20 White balance sensor (→ 47)

Lens cover

For the lens protection, be sure to close the lens cover when not in use.

Slide the lens cover open/close switch.

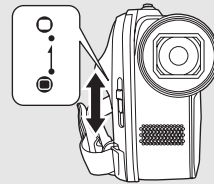

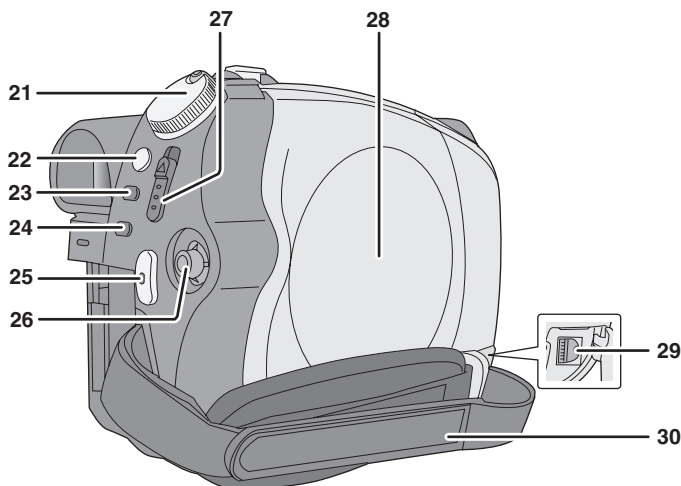

- 21 Mode dial (→ 24)
- 22 Image stabilizer button [(Ⓜ), O.I.S.] (→ 39)
- 23 Menu button [MENU] (→ 26)
- 24 Delete button [Ⓜ] (→ 55)
- 25 Recording start/stop button (→ 33, 35)
- 26 Joystick

- 27 Disc eject lever [DISC EJECT] (→ 21)
- 28 Disc compartment (→ 21)
- 29 Audio-video output terminal [A/V] (→ 68, 70)
- 30 Grip belt

Joystick

Use the joystick to select the recording functions and playback operations, and to operate the menu screen.

Move the joystick up, down, left, or right to select a setting or scene, and then press the joystick to set it.



- ① Select by moving up, down, left or right.
- ② Set by pressing the centre.
 - Menu screen operations (→ 26)
 - To select the recording functions (→ 40)
 - To adjust manually (→ 45)
 - Playback operations (→ 50, 53)

Grip belt

Adjust the belt length and the pad position.

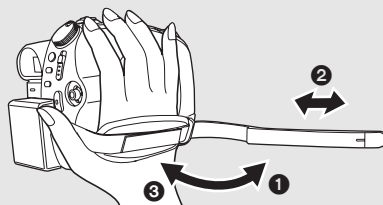

- ① Flip the belt.
- ② Adjust the length.
- ③ Replace the belt.

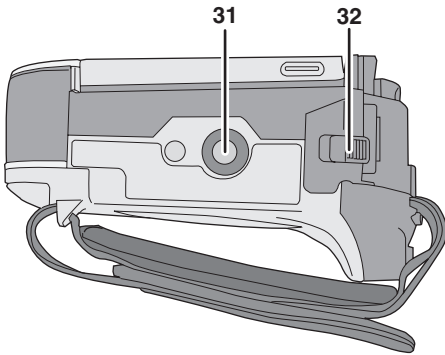

31 Tripod receptacle

32 Battery release lever [BATTERY] (→ 15)

Tripod receptacle

This is a hole for attaching the unit to the optional tripod.

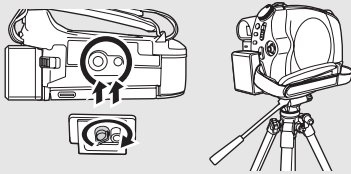

■ About batteries that you can use with this unit

The Panasonic battery that can be used with this unit is supplied battery/VW-VBG130/VW-VBG260/VW-VBG6.

Supplied battery/VW-VBG130/VW-VBG260/VW-VBG6 come with a function to check whether the battery and unit can be safely used together.

- The battery pack holder kit VW-VH04 (optional) is necessary if using VW-VBG6.

It has been found that counterfeit battery packs which look very similar to the genuine product are made available to purchase in some markets. Some of these battery packs are not adequately protected with internal protection to meet the requirements of appropriate safety standards. There is a possibility that these battery packs may lead to fire or explosion. Please be advised that we are not liable for any accident or failure occurring as a result of use of a counterfeit battery pack. To ensure that safe products are used we would recommend that a genuine Panasonic battery pack is used.

- Be aware that many batteries sold at extremely cheap prices or in situations where it is difficult to verify the actual products before purchase have proven to be counterfeit.

Charging the battery

When this unit is purchased, the battery is not charged. Charge the battery before using this unit.

Important:

If the DC cable is connected to the AC adaptor, then the battery will not charge. Remove the DC cable from the AC adaptor.

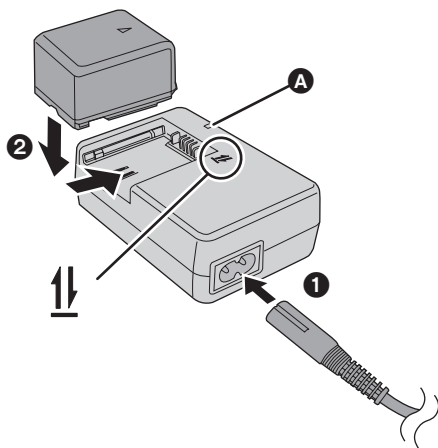

Charging lamp [CHARGE] A

Lights up:

Charging (→ 15, Charging time)

Goes off:

Charging completed

Flashing:

- When the battery temperature is excessively high or low, the lamp flashes and the charging time will be longer than normal.
- Remove dirt, foreign objects or dust on the terminals of the battery or the AC adaptor. If the lamp is still flashing, something may be wrong with the battery or AC adaptor. Contact your dealer.

1 Connect the AC cable to the AC adaptor and the AC outlet.

2 Insert the battery into the battery charger by aligning the arrows.

- We recommend using Panasonic batteries. (→ 8, 15)
- If you use other batteries, we cannot guarantee the quality of this product.

Inserting the battery

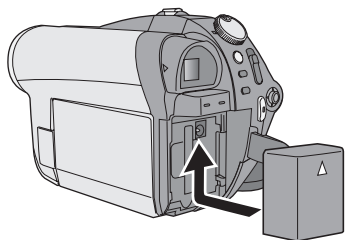

Push the battery against the battery holder and slide it until it clicks.

- Before removing the battery, be sure to set the mode dial to OFF and check that the status indicator is off.
- Do not heat or expose to flame.
- Do not leave a battery pack in an automobile exposed to direct sunlight for a long period of time with doors and windows closed.

Removing the battery

While sliding the BATTERY lever, slide the battery to remove it.

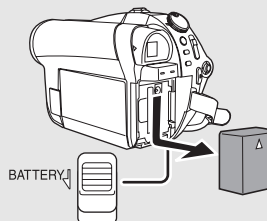

- Hold the battery with your hand so that it does not fall.

CAUTION

Danger of explosion if battery is incorrectly replaced. Replace only with the same or equivalent type recommended by the manufacturer. Dispose of used batteries according to the manufacturer's instructions.

Warning

Risk of fire, explosion and burns. Do not disassemble, heat above 60 °C or incinerate.

Charging time and recordable time

■ Charging time

- Temperature: 25 °C/humidity: 60%

Battery model number	Voltage/capacity	Charging time
Supplied battery	7.2 V/770 mAh	1 h 35 min
VW-VBG130 (optional)	7.2 V/1320 mAh	2 h 35 min
VW-VBG260 (optional)	7.2 V/2640 mAh	4 h 40 min
VW-VBG6 (optional)	7.2 V/5800 mAh	9 h 25 min

- If the temperature is higher or lower than 25 °C, the charging time will become longer.

■ Recordable time

- Temperature: 25 °C/humidity: 60%
- When using the viewfinder (times in parentheses are when using the LCD monitor)
- When using a DVD-RAM disc

Battery model number	Voltage/capacity	Recording mode	Maximum continuously recordable time	Actual recordable time
Supplied battery	7.2 V/ 770 mAh	XP	1 h 5 min (1 h)	40 min (35 min)
		SP	1 h 15 min (1 h 10 min)	40 min (40 min)
		LP	1 h 20 min (1 h 15 min)	40 min (40 min)
VW-VBG130 (optional)	7.2 V/ 1320 mAh	XP	1 h 55 min (1 h 45 min)	1 h 10 min (1 h 5 min)
		SP	2 h 10 min (2 h)	1 h 15 min (1 h 5 min)
		LP	2 h 20 min (2 h 5 min)	1 h 15 min (1 h 5 min)
VW-VBG260 (optional)	7.2 V/ 2640 mAh	XP	4 h 5 min (3 h 45 min)	2 h 30 min (2 h 15 min)
		SP	4 h 35 min (4 h 10 min)	2 h 35 min (2 h 25 min)
		LP	4 h 55 min (4 h 30 min)	2 h 40 min (2 h 25 min)
VW-VBG6 (optional)	7.2 V/ 5800 mAh	XP	9 h 25 min (8 h 40 min)	5 h 50 min (5 h 20 min)
		SP	10 h 40 min (9 h 40 min)	6 h 10 min (5 h 35 min)
		LP	11 h 25 min (10 h 20 min)	6 h 15 min (5 h 40 min)

- These times are approximations.
- The actual recordable time refers to the recordable time on a disc when repeatedly starting/stopping recording, turning the unit on/off, moving the zoom lever, etc.
- The recordable times will vary depending on the status of use.
- Be aware that low temperatures will shorten the amount of time the battery will remain charged. We recommend carrying a spare battery.
- The batteries heat up after use or charging. This unit will also heat up while being used. This is not a malfunction.

Battery capacity indication

- The display changes to the following indications step-by-step as the battery capacity decreases.



- If the battery discharges, then () will flash.

Connecting to the AC outlet

Important:

While the DC cable is connected to the AC adaptor, the battery will not charge.

The unit is in the standby condition when the AC adaptor is connected. The primary circuit is always "live" as long as the AC adaptor is connected to an electrical outlet.

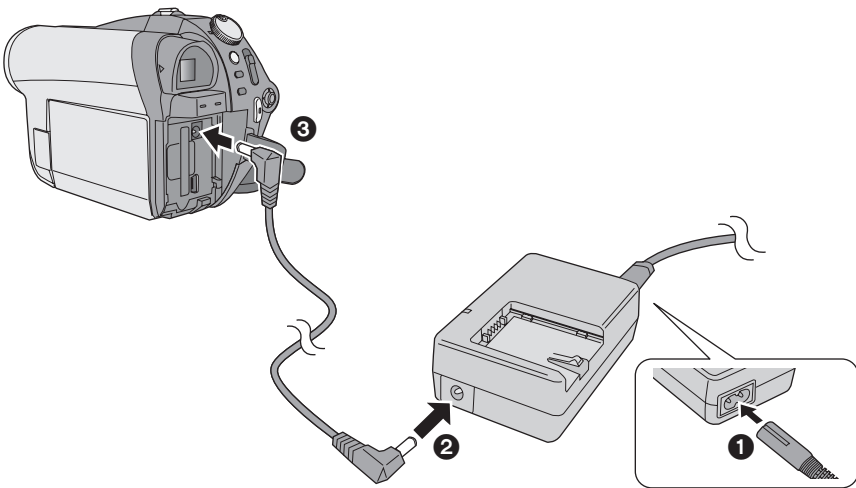













1 Connect the AC cable to the AC adaptor and the AC outlet.

2 Connect the DC cable to the AC adaptor.

3 Connect the DC cable to this unit.

- Do not use the AC cable with any other equipment as it is designed only for this unit. Do not use the AC cable from other equipment with this unit.

■ Disc type

Disc type	DVD-RAM 8 cm Single sided/ double sided	DVD-RW 8 cm Single sided/double sided		DVD-R 8 cm Single sided/ double sided	DVD-R DL 8 cm Dual layer on single side
					
Recording format	VR format	VR format	Video format	Video format	Video format
Display on the screen					
Indication in these instructions					

About format types

What is the VR format (DVD Video Recording format)?

This is a format for recording on DVD discs which allows you to record and erase repeatedly and create playlists. You can record on DVD-RAM and DVD-RW discs in VR format with this unit.

What is the Video format (DVD-Video format)?

By finalizing the disc, it can be played back on most DVD players.

You can record on DVD-RW and DVD-R/ DVD-R DL discs in Video format with this unit.

■ About DVD-R DL (Dual Layer) disc

DVD-R DL (Dual Layer) discs have two layers of recording/playback surface on one side.

If the first layer (L0) becomes full during recording, the recording continues uninterrupted on the second layer (L1). However, the recording is divided into 2 scenes at the point where the layers switch. This unit automatically switches layers during disc playback so you can play the whole of the disc continuously like a normal disc. However, the picture or the sound momentarily stops at the point where the layers switch.

■ Examples of discs that cannot be used on this unit

- Discs other than those with diameter of 8 cm
- Double layer discs other than DVD-R DL
- Blu-ray Disc
- HD DVD
- +RW
- +R
- +R DL
- DVD-ROM
- DVD-Video
- CD-RW
- CD-R
- CD-ROM
- CD

■ Disc characteristics

Disc type	DVD-RAM	DVD-RW (VR format)	DVD-RW (Video format)	DVD-R	DVD-R DL
Rewritable disc	●	●	●*1	–	–
Deleting recorded scenes	●	●	–	–	–
Editing on this unit	●	●	–	–	–
Playback on other products*2	●*3	●*3*4	●*4	●*4	●*3*4
Recording after finalizing	●*5	●	●*6	–	–

●: applicable –: not applicable

*1 By formatting the disc, it can be used repeatedly. (→ 67)

*2 DVD players and DVD recorders that support 8 cm discs.

*3 Playback is possible on compatible products.

*4 Must be finalized on this unit. (→ 64)

*5 Does not need to be finalized.

*6 Un-finalize the disc. (→ 65)

● Still pictures cannot be recorded on a disc with this unit.

- You cannot record or play continuously from one side of the disc to the other when using a double sided disc. You will need to eject the disc and turn it over.
- Discs inserted in a holder, cartridge, or caddy case cannot be used unless they are removed from the containers prior to use.
- It is recommended that you use Panasonic discs. Usually discs compatible with the DVD standard can be used for recording and playback with no problems. However, some commercially available discs do not meet the DVD standard for quality and performance. If you use one of these discs, you may not be able to record or playback normally. (The message "FOR BEST PERFORMANCE PANASONIC DISC IS RECOMMENDED." appears.) Refer to the following support site for information about discs that have been confirmed as compatible by Panasonic.
http://panasonic.jp/support/global/cs/fe_cam
(This website is in English only.)

● Discs recorded on this unit may not be playable on other products.

- Recording on a DVD-R/DVD-R DL disc in VR format is not supported.

● When using DVD-RW or DVD-R/DVD-R DL discs, do not perform the following as it may make the disc unusable.

- Record on a disc with other products after recording on it with this unit.
- Record on a disc with this unit after recording on it with other products.
- Insert a disc that has not been finalized into other products.

When using a new DVD-RW disc

When using a DVD-RW disc, select whether to record in VR format or Video format and then format the disc. (→ 18, About format types)
When a new DVD-RW disc is used, the screen shown in the illustration appears.

1 Select [YES], then press the joystick.

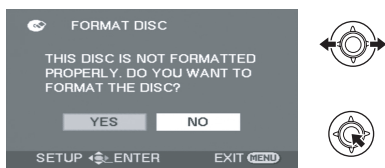

2 Select format type, then press the joystick.



[VIDEO]:

Video format (Cannot edit or delete scenes)

[VR]:

VR format (Allows editing and deleting of scenes)

3 When the confirmation message appears Select [YES], then press the joystick.

- If the disc is formatted, then all the data recorded on the disc will be erased.
- To change the format type, format the disc again. (→ 67)

Disc handling

- Do not touch the recording/playback surface.

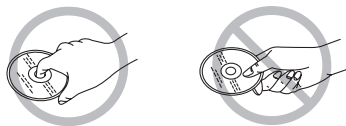

- If there are scratches, dirt or fingerprints on the recording/playback side of the disc, images cannot be recorded or played back normally and the following phenomena may occur:
 - Recording or playback becomes impossible.
 - Playback image stops momentarily or sound is interrupted during playback.
 - Block noise appears on playback images.
- If there is dirt on the disc, wipe with a damp cloth and then wipe dry.

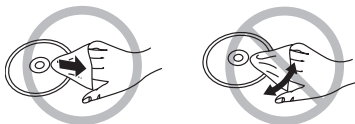

- Do not attach labels or stickers to discs.
- Do not use ballpoint pens or other hard writing implements to write on a label. Use a soft fiber pen with solvent ink.
- Do not use solvents to clean the disc.
- Do not drop, stack, or impact discs. Do not place objects on them.
- Do not use the following discs:
 - Discs that are badly warped or cracked.
 - Irregularly shaped discs, such as heart shapes.



- Do not leave discs in the following areas.
 - In direct sunlight.
 - In very dusty or humid areas.
 - Near a heater.
 - Locations susceptible to significant difference in temperature (condensation can occur).
- To protect discs, keep them in their cases when not being used.

Inserting/removing a disc

- The cover of the disc compartment will not open unless the unit has a charged battery or is connected to the AC adaptor.

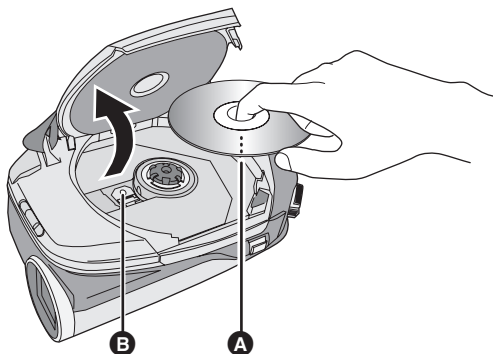

- A** Set the recording/playback side to the inside.
- B** Pickup lens (reads disc)

1 Insert a charged battery or connect the AC adaptor.

2 Slide the DISC EJECT lever up and release it.

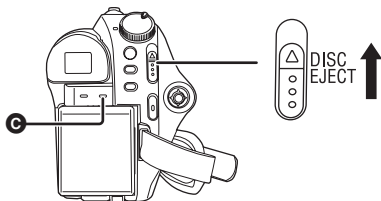

3 Open the cover of the disc compartment and insert/remove the disc.

- Place the disc onto the spindle in the centre and then push the disc down until it clicks into place.
- While pressing down on the spindle, grasp the edge of the disc and gently lift it out.

4 Push the section marked PUSH CLOSE to close the cover.

- Do not remove the battery pack or disconnect the AC adaptor while removing the disc.
- If the cover is open, the power will not turn off even if the mode dial is set to OFF.
- Do not touch the pickup lens or the recording/playback side of the disc.
- Be sure not to touch the area around the pickup lens for it becomes extremely hot.

Disc access lamp [ACCESS DISC/PC] **C**

When the lamp is on, the disc is rotating and data is being recorded. If the power supply is interrupted, the disc may become damaged. Do not disconnect the AC adaptor or remove the battery. Also, do not shake or bump the unit while the lamp is on.

Card type	SD Memory Card	SDHC Memory Card
Capacity	8 MB, 16 MB, 32 MB, 64 MB, 128 MB, 256 MB, 512 MB, 1 GB, 2 GB	4 GB, 8 GB
Indication in these instructions	SD	

This unit is compatible with both SD Memory cards and SDHC Memory cards. You can only use SDHC Memory cards on devices that are compatible with them. You cannot use SDHC Memory cards on devices that are only compatible with SD Memory cards. (When using an SDHC Memory card on another device, be sure to read the operating instructions for that device.)

- For the purposes of these operating instructions, SD Memory Card and SDHC Memory Card are referred to as the “SD card”.
- **Motion pictures cannot be recorded on an SD card with this unit.**
- Please confirm the latest information on the following website. (This website is in English only.)
http://panasonic.jp/support/global/cs/e_cam
- This unit supports SD Memory Cards formatted in FAT12 system and FAT16 system based on SD Memory Card Specifications and SDHC Memory Cards formatted in FAT32 system.
- If you wish to use Memory Cards that are 4 GB and 8 GB, only SDHC Memory Cards can be used.
- 4 GB (or more) Memory Cards that do not have the SDHC logo are not based on SD Memory Card Specifications.
- Use this unit to format SD cards. If an SD card is formatted on other products (such as a PC), the time spent for recording may become longer and you may not be able to use the SD card. (→ 67)
- We recommend that you use a Panasonic brand SD card.
- When the write-protect switch **A** on SD card is locked, no recording, deletion or editing will be possible on the card.
- Keep the Memory Card out of reach of children to prevent swallowing.
- A MultiMediaCard cannot be used on this unit.

■ About the miniSD Card

- Be sure to insert miniSD Cards in the dedicated card adaptor before use. Inserting a card in this unit without the adaptor may damage the unit or the card.
- Do not insert an empty card adaptor in this unit. Do not leave the adaptor in this unit while inserting or removing miniSD Cards. This may cause the unit to malfunction.

SD card handling

- Do not touch the terminals on the back of the SD card.
- Do not expose the terminals of the SD card to water, debris, dirt or dust.
- Do not leave the SD cards in the following areas:
 - In direct sunlight.
 - In very dusty or humid areas.
 - Near a heater.
 - Locations susceptible to significant difference in temperature (condensation can occur).
 - Where static electricity or electromagnetic waves occur.
- To protect SD cards, keep them in their cases when not being used.
- Electrical noise, static electricity or failure of this unit or the SD card may damage or erase the data stored on the SD card. We recommend saving the SD data on a PC.

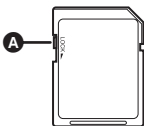

Inserting/removing an SD card

Caution:

If the SD card is inserted or removed while the power is on, this unit may malfunction or the data recorded on the SD card may be lost.

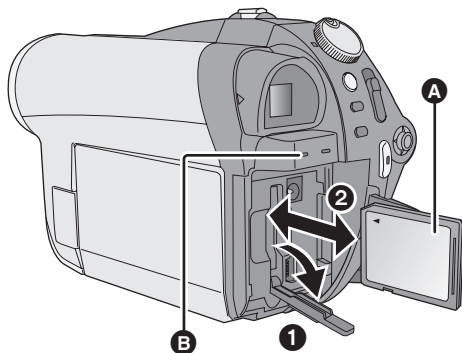

A Label side

1 Set the mode dial to OFF and remove the battery.

- Check that the status indicator has gone off.

2 Open the SD card slot cover.

3 Insert/remove the SD card.

- Press the SD card straight in as far as it will go.
- Press the centre of the SD card and then pull it straight out.

4 Securely close the SD card slot cover.

SD card access lamp [ACCESS CARD] **B**

- When this unit is processing data, the lamp lights up.
- When lamp is on, do not:
 - Remove the SD card
 - Operate the mode dial
 - Remove the battery or disconnect the AC adaptor
- Performing the above while lamp is on may result in damage to data/SD card or this unit.

Turning the unit on/off Selecting a mode

Rotate the mode dial to switch to recording, playback or power OFF.

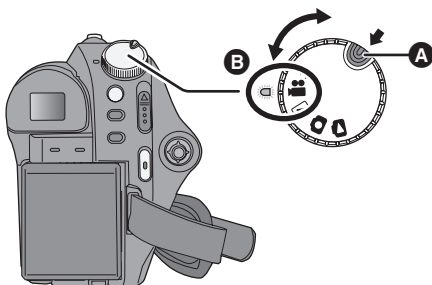

- Rotate the mode dial while at the same time pressing in the lock release button **A** if changing from OFF to another mode.
- Align with the status indicator **B**.

While pressing the lock release button, set the mode dial to , , or to turn on the power.





The status indicator lights and the power turns on.

- When the unit is turned on for the first time, a message asking you to set the date and time will appear. Select [YES] and set the date and time. (→ 29)

To turn off the power

Set the mode dial to OFF.

- The status indicator goes off and the power turns off.

	Video recording mode (→ 33)
	Video playback mode (→ 50)
	Picture recording mode (→ 35)
	Picture playback mode (→ 53)
OFF	

To start recording immediately



Use the following steps to make the unit recognise the disc.

- 1) Insert a disc.
- 2) Turn on the power.
- 3) After "READING DISC..." disappears from the screen, turn off the power.

You can start recording immediately when you turn on the power again.

- Set the date and time to use this function.

How to turn the power on and off with the LCD monitor/viewfinder

When the mode dial is set to  or , the power can be turned on and off with the LCD monitor and the viewfinder.

■ To turn on

Open the LCD monitor or extend the viewfinder.

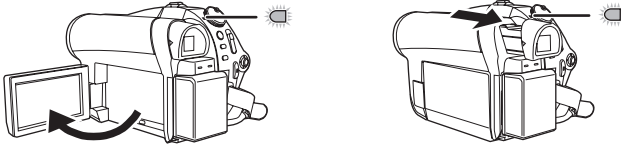

The status indicator lights.

■ To turn off

Close the LCD monitor and retract the viewfinder.

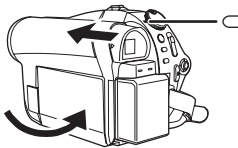

The status indicator goes off.

Set the mode dial to OFF when this unit is not being used.

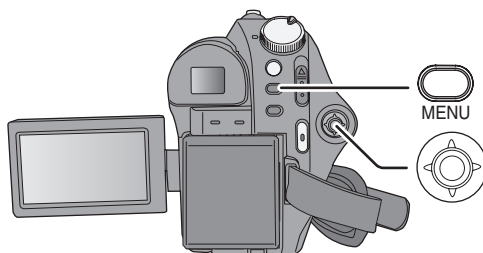

1 Press the MENU button.

The menu displayed differs depending on the position of the mode dial.

2 Select the desired top menu, then move the joystick right or press the joystick.



3 Select the submenu item, then move the joystick right or press the joystick.

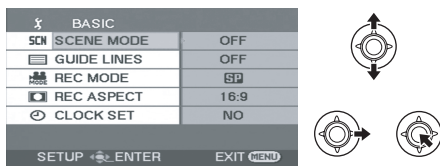

4 Select the desired setting, then press the joystick to enter the selection.

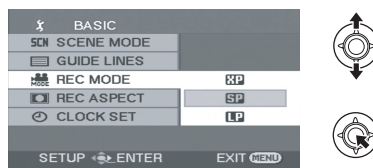

To get back to the previous screen

Move the joystick left.

To exit the menu screen

Press the MENU button.

- Do not switch the mode dial when the menu is displayed.
- The menu screen does not appear during recording or playing. You cannot start other operations while the menu screen is displayed.

Language selection

You can select the language displayed on the screen.

1 Press the **MENU** button, then select **[LANGUAGE]** and press the joystick.

2 Select **[English]** and press the joystick.

Menu list

Motion picture recording menus

■ [BASIC]

[SCENE MODE] (→ 46)

[GUIDE LINES] (→ 44)

[REC MODE] (→ 34)

[REC ASPECT] (→ 44)

[CLOCK SET] (→ 29)

■ [ADVANCED]

[D.ZOOM] (→ 38)

[FADE COLOUR] (→ 42)

[WIND CUT] (→ 44)

[ZOOM MIC] (→ 38)

[AUTO SLW SHTR] (→ 44)

■ [DISC SETUP]

[FORMAT DISC] (→ 67)

[INFORMATION] (→ 66)

■ [SETUP]

[DISPLAY]

- [OFF]
- [ON]

The screen indications are selected as shown in the illustration below.

[OFF]

[ON]

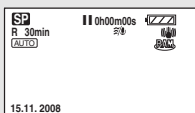

[DATE/TIME] (→ 29)

[DATE FORMAT] (→ 29)

[POWER SAVE]

- [OFF]
- [5 MINUTES]

[OFF]:

The power saving function is not activated.

[5 MINUTES]:

When about 5 minutes have passed without any operation, this unit automatically turns off to save battery life. To use this unit, turn it on again.

- When using the AC adaptor, connecting the unit to a PC or a printer via the USB cable, the power saving function will not activate.

[BEEP SOUND]

- [OFF]
- [ON]

This allows operations such as starting and ending recording to be signaled by a beep.

1 Beep

When you start recording

When you turn on the power

When this unit is recognised by the PC or the printer, etc.

2 Beeps

When you pause recording

When you turn off the power

2 Beeps for 4 times

When an error occurs e.g. recording not starting. Check the sentence displayed on the screen. (→ 88)

[LCD SET] (→ 30)

[EVF SET] (→ 30)



[INITIAL SET]

- [YES]
- [NO]

When there is a menu that cannot be selected due to another function or mode being activated, set to [YES] for changing the menu settings back to the default condition. (The language setting cannot be changed back to the default condition.)

[DEMO MODE]

- [OFF]
- [ON]

This is used to start the unit demonstration. (Only when using the AC adaptor and the mode dial is at the  or  position) If you set this to [ON] without inserting a disc or an SD card, this unit is automatically set to the demonstration mode for introducing its functions. If any button is pressed or operated, the demonstration mode is cancelled. If no operations take place for approx. 10 minutes, the demonstration mode automatically starts. To terminate the demonstration mode, set this to [OFF]. For normal use, set this function to [OFF].

- [LANGUAGE] (→ 27)

Still picture recording menus

■ [BASIC]

- [SCENE MODE] (→ 46)
- [GUIDE LINES] (→ 44)
- [PICTURE SIZE] (→ 36)
- [PICT.QUALITY] (→ 36)
- [CLOCK SET] (→ 29)

■ [ADVANCED]

- [SHTR EFFECT] (→ 36)
- [AUTO SLW SHTR] (→ 44)

■ [SETUP]

- [FORMAT CARD] (→ 67)
- For other items, refer to the motion picture recording menus.

- [LANGUAGE] (→ 27)

Motion picture playback menus

■ [EDIT SCENE]

- [DIVIDE] (→ 57)
- [COMBINE] (→ 58)
- [DELETE] (→ 55)

(In playlist playback mode)

■ [EDIT]

- [ADD] (→ 60)
- [MOVE] (→ 61)
- [DIVIDE] (→ 61)
- [COMBINE] (→ 61)
- [DELETE] (→ 55, 60)

■ [DISC SETUP]

- [FINALIZE] (→ 64)
- [UN-FINALIZE] (→ 65)
- [DISC PROTECT] (→ 66)
- [FORMAT DISC] (→ 67)
- [INFORMATION] (→ 66)

■ [SETUP]

- [RESUME PLAY] (→ 52)
- [TV ASPECT] (→ 68)
- For other items, refer to the motion picture recording menus.

- [LANGUAGE] (→ 27)

Still picture playback menus

■ [PHOTO SETUP]

- [LOCK SET] (→ 62)
- [DPOF SET] (→ 63)
- [DELETE] (→ 55)

■ [SETUP]

- [FORMAT CARD] (→ 67)
- [TV ASPECT] (→ 68)
- For other items, refer to the motion picture recording menus.

- [LANGUAGE] (→ 27)

When the unit is turned on for the first time, a message asking you to set the date and time will appear. Select [YES] and press the joystick. Perform steps 2 and 3 below to set the date and time.

◇ Rotate the mode dial to select  or .

1 Select the menu. (→ 26)

[BASIC] → [CLOCK SET] → [YES]

2 Select the date or time to be set, then set the desired value with the joystick.

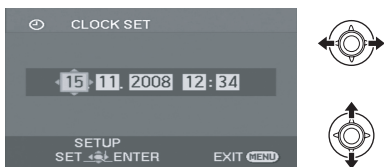

- The year will change as follows: 2000, 2001, ..., 2099, 2000, ...
- The 24-hour system is used to display the time.

3 Press the joystick to enter the selection.

- The clock function starts at [00] seconds when the joystick is pressed.

4 Press the MENU button to finish the setting.

- Check the date and time displayed.

■ Changing the date and time display mode

Select the menu. (→ 26)

[SETUP] → [DATE/TIME] → desired display style

[DATE]

[D/T]

15.11.2008

15.11.2008 12:34

[OFF]

■ Changing the date format

Select the menu. (→ 26)

[SETUP] → [DATE FORMAT] → desired display style

Display style	Screen display
[Y/M/D]	2008.11.15
[M/D/Y]	11.15.2008
[D/M/Y]	15.11.2008

- The date and time function are driven by a built-in lithium battery.
- If the time display becomes [- -], the built-in lithium battery needs to be charged. Use the following steps to charge the battery. Complete the following steps to charge the battery and then set the date and time.

To recharge the built-in lithium battery

Connect the AC adaptor or attach the battery to the unit, and the built-in lithium battery will be recharged. Leave the unit as it is for approx. 24 hours and the battery will save the date and time for approx. 6 months. (Even if the mode dial is set to OFF, the battery is still being recharged.)

WARNING

THE LITHIUM BATTERY IN THIS UNIT MUST ONLY BE REPLACED BY QUALIFIED PERSONNEL. IF THIS IS NECESSARY, CONTACT THE PANASONIC CUSTOMER CARE CENTRE ON 132600 FOR YOUR NEAREST AUTHORIZED SERVICE CENTRE.

Adjusting LCD monitor/ viewfinder

- These settings will not affect the images actually recorded.

Adjusting the brightness and colour level

1 Select the menu. (→ 26)

[SETUP] → [LCD SET] or [EVF SET] → [YES]

2 Select the item and then adjust the settings with the joystick.



■ [LCD SET]

[BRIGHTNESS]:

Brightness of the LCD monitor

[COLOUR]:

Colour level of the LCD monitor

■ [EVF SET]

- To adjust the brightness of the viewfinder, extend the viewfinder and close the LCD monitor to activate the viewfinder.

[BRIGHTNESS]:

Brightness of the viewfinder

Adjusting the viewfinder field of view

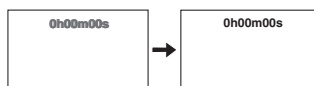
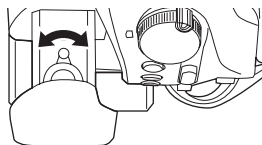

Adjust the focus by sliding the eyepiece corrector knob.

Preparation

Recording

Playback

With a PC

Others

- 32** Recording (Basic)
- 40** Recording (Advanced)

Basic camera positioning



- 1 Hold the camera with both hands. Put your hand through the grip belt. Do not cover the microphones or sensor with your hands.

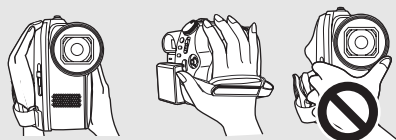

- 2 Keep your arms near your body.
 - 3 Separate your legs for better balance.
- When you are outdoors, record pictures with the sunlight behind you. If the subject is backlit, it will become dark in the recording.
 - When recording, make sure your footing is stable and there is no danger of colliding with another person or an object.

■ About auto mode

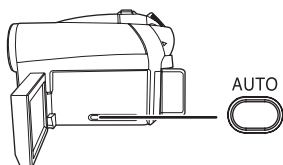

Press the AUTO button, colour balance (white balance) and focusing will be adjusted automatically.

(The auto mode icon [**AUTO**] appears.)

- Auto white balance (→ 100)
- Auto focusing (→ 100)

Depending on the brightness of the subject etc., the aperture and shutter speed are automatically adjusted for optimum brightness.

(When set to the video recording mode: The

shutter speed is adjusted to a maximum of 1/250.)

- Colour balance and focus may not be adjusted automatically depending on light sources or scenes. If so, manually adjust these settings. (→ 45)

RAM -RW(VR) -RW(V) -R -R DL

- Open the lens cover before turning the unit on.

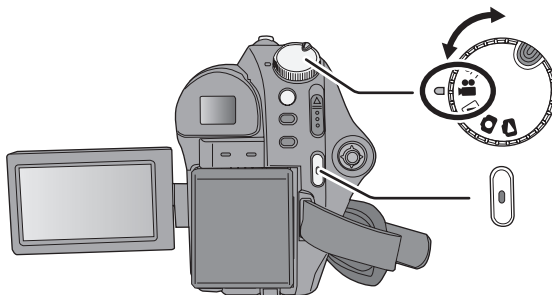

1 Rotate the mode dial to select  and open the LCD monitor or extend the viewfinder.

2 Press the recording start/stop button to start recording.

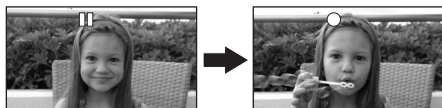

To end the recording

Press the recording start/stop button again.

- [●] and [||] are red during recording. Do not move this unit until [||] is green.

- The images recorded between pressing the recording start/stop button to start recording and pressing it again to pause recording become one scene.
- When about 5 minutes have passed without any operation in recording pause, this unit automatically turns off to save battery life. To use this unit, turn it on again. This power save feature can also be set to [OFF]. (→ 27, [POWER SAVE])

■ Screen indications

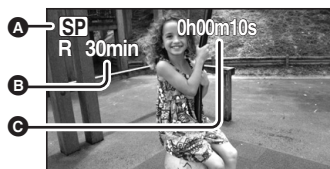

- A Recording mode**
- B Remaining time left for recording**
When the remaining time is less than 1 minute, [R 0min] flashes red.
- C Recording time elapsed**
Each time the unit enters the recording pause mode, the counter display will be reset to "0h00m00s".

- Maximum number of scenes on one side of a disc: 999
Maximum number of dates on one side of a disc: 99
(In some cases, scenes shot on the same day will be recorded with different dates (→ 52))
When either of them reaches to the maximum limit, more scenes cannot be recorded.
- While motion picture recording is in progress, the recording will not stop even if the LCD monitor is closed and the viewfinder is retracted.

- While motion picture recording is in progress, do not disconnect the AC adaptor or remove the battery. If you do, a repair disc message may be displayed when the power is turned back on. (→ 89, About recovery)

While “WRITING CONTROL DATA TO DISC. DO NOT SHAKE THE UNIT.” is displayed, or while the ACCESS DISC/PC lamp lights, the disc is rotating and disc information is being recorded. If you shake the unit, the recorded images may be distorted, so do not strongly shake or strike the camera. Also, do not disconnect the AC adaptor or remove the battery as doing so may make the disc unusable.

Recording modes and recordable time

To change the picture quality of the motion picture

Select the menu. (→ 26)

[BASIC] → [REC MODE] → desired setting

■ Approximate recordable time for one side of a disc

Recording mode	Disc type	
	DVD-RAM	DVD-R DL
XP (High quality)	18 min	35 min
SP (Normal)	37 min	69 min
LP (Long play)	75 min	138 min

- This unit records in VBR (Variable Bit Rate). VBR recording automatically varies the bit rate (amount of data in a fixed time) depending on the subject being recorded. This means if a recording with a lot movements is recorded, the recording time is reduced.
-
- Mosaic-pattern noise may appear on a playback image in the following cases.
 - When there is a complicated pattern in the background
 - When the unit is moved too fast
 - When a subject with sharp movements has been recorded (Particularly if it has been recorded in [LP] mode.)

- Open the lens cover before turning the unit on.

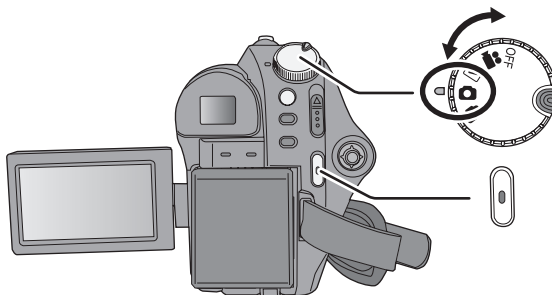

1 Rotate the mode dial to select  and open the LCD monitor or extend the viewfinder.

2 Press the recording start/stop button.

The unit automatically focuses on the subject at the centre of screen (when auto focus is selected).

- About the number of recordable still pictures on an SD card (→ 104)

■ To record still pictures clearly

- When zooming in on the subject with a magnification of 4× or higher, it is difficult to reduce the slight shaking from holding this unit by hand. We recommend decreasing the zoom magnification and approaching the subject when recording.
- When recording still pictures, hold the unit firmly with your hands and keep your arms stationary at your side so as not to shake the unit.
- You can record stable pictures without shaking by using a tripod.

■ Screen indications



- A Remaining number of still pictures**
Flashes in red when [R 0] appears.
- B Size of still pictures**
- C Quality of still pictures**

Recording with a shutter sound effect

Select the menu. (→ 26)

[ADVANCED] → [SHTR EFFECT] → [ON]



- This function's default setting is [ON].

Number of pixels and picture quality

■ [PICTURE SIZE]

Select the menu. (→ 26)

[BASIC] → [PICTURE SIZE] → desired setting



Icon	Aspect	Number of pixels
	4:3	640×480
	16:9	640×360

- Default [PICTURE SIZE] is set to . The sides of pictures recorded with a 16:9 aspect ratio may be cut at printing. Check before printing.

■ [PICT.QUALITY]

Select the menu. (→ 26)

[BASIC] → [PICT.QUALITY] → desired setting

- : Still pictures with a high picture quality are recorded.
- : Priority is given to the number of still pictures recorded. Still pictures are recorded in normal picture quality.



- If the [PICT.QUALITY] is set to , mosaic-pattern noise may appear on a playback image depending on the picture content.

Zoom in/out function

RAM -RW(VR) -RW(V) -R -R DL SD

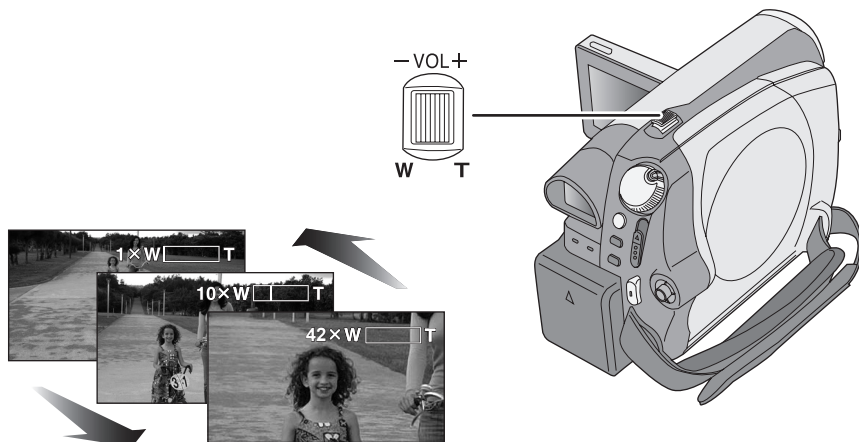
You can zoom in up to 42× optically.



◇ Rotate the mode dial to select  or .

Move the zoom lever.

T side:

Close-up recording (zoom in)

W side:

Wide-angle recording (zoom out)

- The zoom speed varies depending on the range over which the zoom lever is moved.

- If you take your finger off the zoom lever during zoom operation, the operation sound may be recorded. When returning the zoom lever to the original position, move it quietly.
- When distant subjects are brought closer, they are focused at about 1.3 m or more.
- When the zoom magnification is 1×, this unit can focus on a subject approx. 2 cm away from the lens. (Macro function)
- When the zoom speed is high, the subject may not be focused easily.

Digital zoom function

RAM -RW(VR) -RW(V) -R -R DL

If the zoom magnification exceeds 42×, then the digital zoom function will be activated. The maximum magnification provided by the digital zoom can be selected.

◇ Rotate the mode dial to select .

Select the menu. (→ 26)

[ADVANCED] → [D.ZOOM] → desired setting

[OFF]:

Optical zoom only (Up to 42×)

[70x]:

Up to 70×

[2000x]:

Up to 2000×

- If [70x] or [2000x] is selected, the digital zoom range is displayed in blue while zooming.

-
- The larger the digital zoom magnification, the more the image quality is degraded.
 - This function cannot be used in picture recording mode.

To use the zoom microphone function

RAM -RW(VR) -RW(V) -R -R DL

The zoom microphone is linked to the zooming operation so that far-away sounds with a tele-shot and close-up sounds with a wide-angle shot are recorded more clearly.



◇ Rotate the mode dial to select .

Select the menu. (→ 26)

[ADVANCED] → [ZOOM MIC] → [ON]

Recording yourself

RAM -RW(VR) -RW(V) -R -R DL SD

◇ Rotate the mode dial to select  or .

Rotate the LCD monitor towards the lens side.

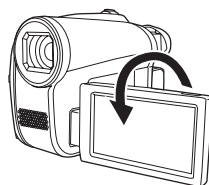

If the viewfinder is extended, the LCD monitor and the viewfinder simultaneously light.

- The image is horizontally flipped as if you see a mirror image. (However the image recorded is the same as a normal recording.)
- When the recording aspect is 16:9, the image displayed on the viewfinder screen is squeezed horizontally, but this is normal and not a sign of any malfunction.



-
- When the LCD monitor is rotated towards the lens side, the icon will not be displayed even if you press the joystick.
 - Only some indications will appear on the screen. When [] appears, return the direction of the LCD monitor to normal position and check the warning/alarm indication. (→ 88)

Image stabilizer function

RAM -RW(VR) -RW(V) -R -R DL SD

Reduces the image shaking due to hand movement when recording.

◇ Rotate the mode dial to select  or .

Press the O.I.S. button.

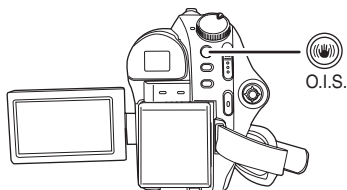

The image stabilizer icon [] appears.

To cancel the image stabilizer function



Press the O.I.S. button again.

- The default setting is on.
- In the following cases, the image stabilizer function may not work effectively.
 - When the digital zoom is used
 - When the unit is shaken greatly
 - When you record a moving subject while tracking it

Recording functions of operation icons

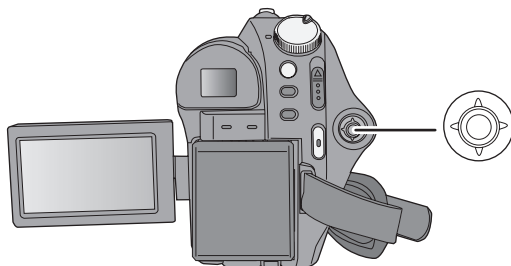
Set the recording functions by selecting the operation icons to add different effects to the recorded images.



◇ Rotate the mode dial to select  or .

1 Press the joystick, and icons will be displayed on the screen.



- The indication changes each time the joystick is moved down.
- The indication disappears when the centre of the joystick is pressed again.

2 Select an icon with the joystick.















To cancel the function

Select the icon again.

Operation icons











Backlight compensation/Fade/Help mode/Colour night view/Soft skin mode/Self-timer

Video recording mode



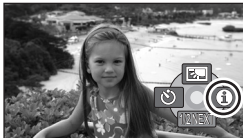





	<p> Backlight compensation</p> 	<p> Fade</p> 	<p> Help mode</p> 
	<p> Colour night view</p> 	<p> Soft skin mode</p> 	

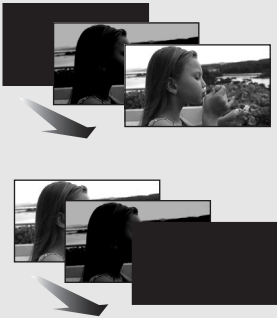

- The shaded operation icons are not displayed while recording.
- If you turn off the power or operate the mode dial, the backlight compensation and the Colour night view functions are cancelled.
- If you turn off the power, the fade function is cancelled.

Picture recording mode

	<p> Backlight compensation</p> 	<p> Self-timer</p> 	<p> Help mode</p> 
	<p> Soft skin mode</p> 		

- If you turn off the power or operate the mode dial, the backlight compensation function is cancelled.
- If you turn off the power, the self-timer function is cancelled.

Function		Effect
 Backlight compensation	RAM -RW(VR) -RW(V) -R -R DL SD	This makes the image brighter to prevent darkening of a backlit subject.
 Fade 	RAM -RW(VR) -RW(V) -R -R DL	When you start recording, the image/audio gradually appears. (Fade in) When you pause recording, the image/audio gradually disappears. (Fade out) <ul style="list-style-type: none"> After the image/audio completely disappears, the recording stops and the fade setting is cancelled. <p>  To select the colour for fade in/out Select the menu. (→ 26) [ADVANCED] → [FADE COLOUR] → [WHITE] or [BLACK] </p>
 Help mode 	RAM -RW(VR) -RW(V) -R -R DL SD	This explains the recording functions. (Only for icons that can be selected in auto mode) <p> Select the desired icon with the joystick to display an explanation on the screen. </p> <hr/> <p> <i>To exit the help mode</i> Press the MENU button or select [EXIT]. </p>
 Colour night view	RAM -RW(VR) -RW(V) -R -R DL	This allows you to record colour subjects in dark locations to stand out against the background. <ul style="list-style-type: none"> Minimum required illumination: approx. 2 lx Attach this unit to a tripod, and you can record images free from vibration. If it is difficult to focus, adjust the focus manually. (→ 46)
 Soft skin mode	RAM -RW(VR) -RW(V) -R -R DL SD	This makes skin colours appear softer for a more attractive appearance. This is more effective if you record a person closely from the torso up.

Function		Effect
 Self-timer		<p>This is for recording still pictures using the timer. Use this function to include yourself in the picture.</p> <p>Press the recording start/stop button, the [📷] indication blinks for about 10 seconds and then the still picture is recorded.</p> <ul style="list-style-type: none"> • After recording, the self-timer is cancelled. <hr/> <p>To stop the timer midway through Press the MENU button. (The self-timer setting is cancelled.)</p>

 **Fade:**

- The thumbnails of scenes recorded using fade in become black (or white).

 **Help mode:**

- When the help mode is used, functions cannot be set.
- When the help mode is used, motion pictures and still pictures cannot be recorded.

 **Colour night view:**

- Recorded scene is seen as if frames were missed.
- The Colour night view function makes the signal charging time of CCD up to approximately 25× longer than usual, so that dark scenes can be recorded brightly. For this reason, bright dots that are usually invisible may be seen, but this is not a malfunction.
- If set in a bright place, the screen may become washed out for a while.

 **Soft skin mode:**























- If the background or anything else in the scene has colours similar to the skin colour, they will also be smoothed.
- If the brightness is insufficient, the effect may not be clear.
- You may not be able to see the face clearly when recording a distant person. In this case, cancel soft skin mode or zoom in on the face.

Recording functions of menus

Menus

Guideline/Aspect ratio/Wind noise reduction/Auto slow shutter

◇ Rotate the mode dial to select  or .

Function		Effect/Setting method
Guideline function	     	<p>You can check if the image is level while recording by using the guidelines displayed on the screen.</p> <p>Select the menu. (→ 26) [BASIC] → [GUIDE LINES] → [ON] • To cancel the function, select [OFF].</p>
Aspect ratio	    	<p>This allows you to record images compatible with wide-screen TVs (16:9) and regular TVs (4:3).</p> <p>Select the menu. (→ 26) [BASIC] → [REC ASPECT] → [16:9] or [4:3] • The default setting is [16:9].</p>
Wind noise reduction function	    	<p>This reduces the winding noise picked up by the microphone.</p> <p>Select the menu. (→ 26) [ADVANCED] → [WIND CUT] → [ON] • The default setting is [ON]. • To cancel the function, select [OFF].</p>
Auto slow shutter mode	     	<p>You can record bright pictures even in dark places by slowing the shutter speed.</p> <p>Select the menu. (→ 26) [ADVANCED] → [AUTO SLW SHTR] → [ON] • The default setting is [ON]. • To cancel the function, select [OFF].</p>

Guideline function:

- The guidelines do not appear on the images actually recorded.
- The guidelines are not displayed while rotating the LCD monitor forward to record yourself.

Wind noise reduction function:

- The wind noise reduction depends on the wind strength. (If this function is activated in strong winds, the stereo effect may be reduced. When

the wind weakens, the stereo effect will be restored.)

Auto slow shutter mode:

- When the auto slow shutter mode is selected, the slowest shutter speed changes from 1/50 to 1/25.
- When the shutter speed becomes 1/25, the screen display may be seen as if frames are missed and afterimages may appear.
- If the scene is low in brightness or contrast, the subject may not be focused in on.

RAM -RW(VR) -RW(V) -R -R DL SD

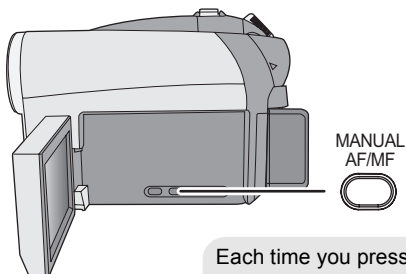

1



2



Each time you press the MANUAL AF/MF button:

1 Manual mode

The icon shown in the illustration appears.



WB White balance

IRIS Aperture adjustment

SHTR Shutter speed

2 Manual focus mode

The manual focus indication [MF] and the icon shown in the illustration appear.



MF Manual focus adjustment

◇ Rotate the mode dial to select  or .

Press the MANUAL AF/MF button.

Scene mode

When you record images in different situations, this mode automatically sets optimum shutter speeds and apertures.

1 Select the manual mode. (→ 45)

2 Select the menu. (→ 26)

[BASIC] → [SCENE MODE] → desired setting

Icon	Mode/Recording conditions
	Sports To record sports scenes or scenes where there are quick motions
	Portrait To make people stand out against the background
	Low light To make the scene brighter in dark conditions
	Spotlight To make the subject under a spotlight look more attractive
	Surf & snow To record images in bright places such as ski slopes and beaches

To cancel the scene mode function

Set [SCENE MODE] to [OFF].

- You can also cancel the scene mode function by pressing the AUTO button.

Sports mode

- For slow-motion playback or playback pause of recorded pictures, this mode helps diminish camera shake.
- During normal playback, the image movement may not look smooth.
- Avoid recording under fluorescent light, mercury light or sodium light because the colour and brightness of the playback image may change.

- If you record a subject illuminated with bright light or a highly reflective subject, vertical lines of light may appear.
- If the brightness is insufficient, the sports mode does not function. The [] display flashes.
- If this mode is used indoors, the screen may flicker.

Portrait mode

- If this mode is used indoors, the screen may flicker. If so, change the scene mode setting to [OFF].

Low light mode

- Extremely dark scenes may not be able to be recorded finely.

Spotlight mode

- If the recording subject is extremely bright, the subject may become washed out and the periphery extremely darkened.

Surf & snow mode

- If the subject is extremely bright, the recorded image may become washed out.

Manual focus adjustment

If auto focusing is difficult due to the conditions, then use manual focus.

1 Select the manual focus mode. (→ 45)

2 Bring the subject into focus with the joystick.



To restore to the automatic adjustment

Press the MANUAL AF/MF button again.

- You can also restore the auto focusing by pressing the AUTO button.

White balance

The automatic white balance function may not reproduce natural colours depending on the scenes or lighting conditions. If so, you can adjust the white balance manually.

1 Select the manual mode. (→ 45)

2 Select [WB] with the joystick.



3 Select the white balance mode with the joystick.

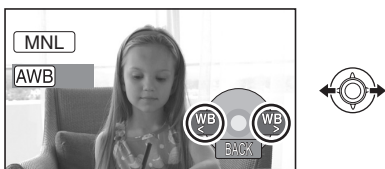

Icon	Mode/Recording conditions
	Auto white balance adjustment
	Indoor mode (for recording under incandescent lamps) Incandescent lights, halogen lamps
	Outdoor mode Outdoors under a clear sky
	Manual adjustment mode <ul style="list-style-type: none"> Mercury-vapor lamps, sodium lamps, some fluorescent lights Lights used for wedding receptions at hotels, stage spotlights in theatres Sunrise, sunset, etc.

To restore to the automatic adjustment

Set the white balance mode to [AWB].

- You can also restore the automatic adjustment by pressing the AUTO button.

To set the white balance manually

1 Select [MNL] with the joystick, and fill the screen with a white subject.

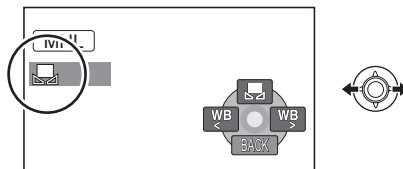

2 Select [MNL] with the joystick.

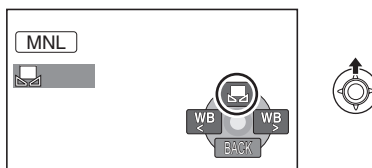

When the [MNL] display stops flashing, the setting is complete.

- If the [MNL] display continues flashing, the white balance cannot be set because it is too dark. In this case, use the automatic white balance.

White balance sensor **A**

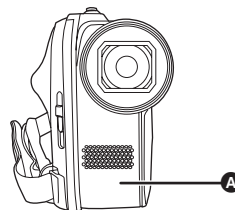

The white balance sensor detects the type of light source during recording.

Do not cover the white balance sensor during recording, or it may not function properly.

- When the unit is turned on with the lens cover closed, the automatic white balance adjustment may not function properly. Please turn the unit on after opening the lens cover.
- When the [MNL] display flashes, the manual white balance previously adjusted is stored.

Whenever recording conditions change, re-set the white balance for correct adjustment.

- When setting both the white balance and the iris/gain, set the white balance first.

Manual shutter speed/ aperture adjustment

SHTR Shutter Speed:

Adjust it when recording fast-moving subjects.

IRIS Aperture:

Adjust it when the screen is too bright or too dark.

1 Select the manual mode. (→ 45)

2 Select [IRIS] or [SHTR] with the joystick.



3 Adjust the settings with the joystick.



A Shutter speed:

 1/25 to 1/8000

 1/25 to 1/500

- The shutter speed closer to 1/8000 is faster.
- If [AUTO SLW SHTR] is set to [OFF], the slowest shutter speed is 1/50.

B Iris/Gain value:

CLOSE → (F16 to F2.0) → OPEN → (0dB to 18dB)

- Value closer to [CLOSE] darkens the image.
- Value closer to [18dB] brightens the image.
- When the iris value is adjusted to brighter than [OPEN], it changes to the gain value.

To restore to automatic adjustment

Press the AUTO button.

- When setting both the shutter speed and the iris/gain value, set the shutter speed and then set the iris/gain value.

Manual shutter speed adjustment

- Avoid recording under fluorescent light, mercury light or sodium light because the colour and brightness of the playback image may change.
- If you increase the shutter speed manually, the noise on the screen may increase.
- You may see vertical lines of light in the playback image of a brightly shining subject or highly reflective subject, but this is not a malfunction.
- During normal playback, image movement may not look smooth.
- When recording in an extremely bright place, the screen may change colour or flicker. If so adjust the shutter speed manually to [1/50] or [1/100].

Manual iris/gain adjustment

- If the gain value is increased, the noise on the screen increases.
- Depending on the zoom magnification, there are iris values that are not displayed.

Preparation

Recording

Playback

With a PC

Others

- 50** Playback
- 55** Editing
- 64** Disc and SD card management
- 68** With other products

Motion picture playback

RAM -RW(VR) -RW(V) -R -R DL

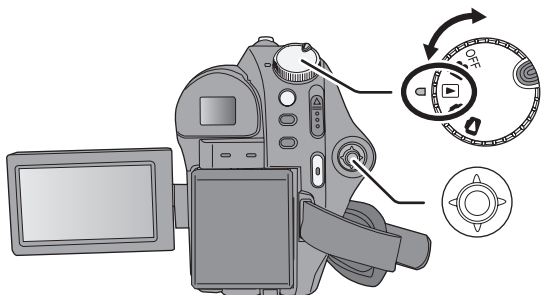



- ▶/||: Playback/Pause
- ◀◀: Skip playback (backward)
- ▶▶: Skip playback (forward)
- : Stops the playback and shows the thumbnails.

1 Rotate the mode dial to select .

2 Select the scene to be played back, then press the joystick.



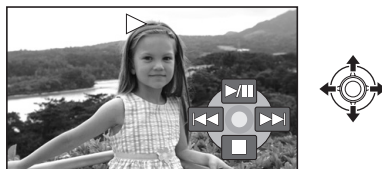

- A** Scene number (Page number: When /  is selected.)
The selected scene is played back, and the operation icon is automatically displayed on the screen.

3 Select the playback operation with the joystick.



Selecting pages

- Select [] / [] and then press the joystick.
- If you move and hold the joystick left or right, you can fast forward or fast rewind the pages. The screen will not change at this time, but the scene or page numbers will change. Release the joystick when you have arrived at the page with the scene you want to display.

- Sound will be heard only during normal playback.
- When the amount of time recorded on the scene is too short, playback may not be possible.
- When a scene is displayed as [(!)] on the thumbnail display, playback is not possible.
- When set to the video playback mode, the power will not turn off even when the LCD monitor and the viewfinder are closed and retracted.
- When playing back a motion picture recorded with other products on this unit or playing back a motion picture recorded with this unit on other products, the picture quality may deteriorate and it may be unplayable. (The message "CANNOT PLAY." appears.)
- The time displayed may be different from the recording time and it may take time to display the thumbnail display when playing back motion pictures recorded on another product.
- The recording time may not display on the screen during playback of scenes recorded on other products.

To change the playback speed

- Normal playback is restored when you move the joystick up.

■ Fast forward/rewind playback

Move and hold the joystick left or right during playback until fast forward/rewind starts.

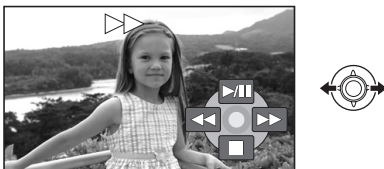

- Move the joystick again to increase the speed.

■ Slow-motion playback

1 Pause the playback.

2 Move and hold the joystick left or right.

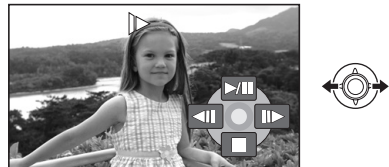

■ Frame-by-frame playback

1 Pause the playback.

2 Move the joystick left or right.

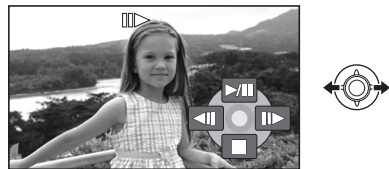

To adjust the speaker volume during playback

Move the volume lever.

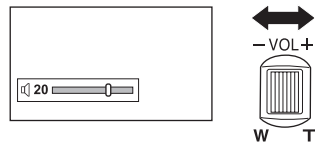

Towards "+": increases the volume
 Towards "-": decreases the volume

Resuming the previous playback

Select the menu. (→ 26)

[SETUP] → [RESUME PLAY] → [ON]

If playback of a motion picture is stopped, [R] appears on the thumbnail view of the stopped scene.

To cancel the resume function

Set [RESUME PLAY] to [OFF].

- The resume position memorised is cleared if you open the disc cover or edit the scenes, etc.

Playing back motion pictures by date

Scenes recorded on the same day can be played back in succession.

1 Select [DATE] (BY DATE), then press the joystick.



2 Select the playback date, then press the joystick.



3 Select the scene to be played back, then press the joystick.

To select a different date

Select [DATE] (BY DATE), then press the joystick.

To return to the screen showing all scenes

Select [ALL] (VIEW ALL), then press the joystick.

- Even if scenes are recorded on the same day, they are grouped separately in the following cases.

– When the number of scenes exceeds 99

RAM -RW(VR) -RW(V) -R -R DL

– When the disc is removed

-RW(V) -R -R DL

– When the [REC ASPECT] setting is changed

-RW(V) -R -R DL

– When the disc is repaired

-RW(V) -R -R DL

– When the layers switch **-R DL**

Playing back a playlist

Creating a new playlist (→ 59)

RAM -RW(VR)

1 Select [PL] (PLAYLIST), then press the joystick.

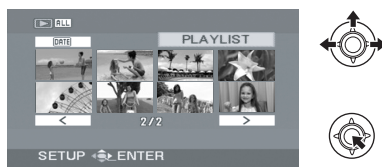

2 Select the playlist to be played back, then press the joystick.



3 Select the scene to start playback, then press the joystick.

To select a different playlist

Select [PL] (PLAYLIST), then press the joystick.

To return to the screen showing the original scenes

Select [ALL] (VIEW ALL), then press the joystick.

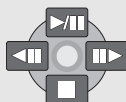
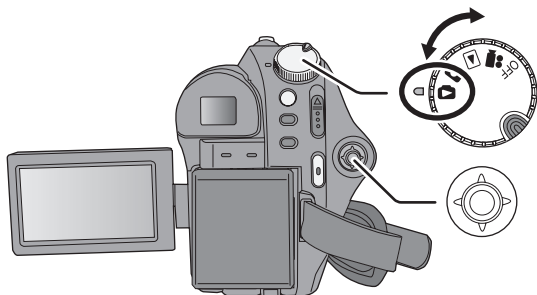

- ▶/||: Slide show start/pause.
- ◀||: Plays back the previous picture.
- ||▶: Plays back the next picture.
- : Stops the playback and shows the thumbnails.



1 Rotate the mode dial to select .

2 Select the file to be played back, then press the joystick.

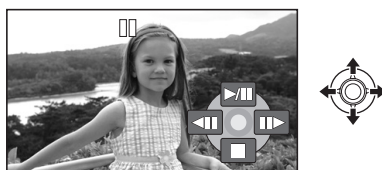

3 Select the playback operation with the joystick.



A File number (Page number: When [] / [] is selected.)

- The method for selecting pages is the same as for motion picture playback.

The selected file is played back, and the operation icon is automatically displayed on the screen.

■ About still picture compatibility

- This unit is compliant with the unified standard DCF (Design rule for Camera File system) established by JEITA (Japan Electronics and Information Technology Industries Association).
- The file format supported by this unit is JPEG. (Not all JPEG formatted files will be played back.)
- If a non-standard file is played back, the folder/file number may not be displayed.
- This unit may degrade or not play back data recorded or created on another product and another product may degrade or not play back data recorded on this unit.

-
- While this unit accesses the SD card (the ACCESS CARD lamp is lit), do not remove the SD card.
 - Do not operate the mode dial during the slide show.
 - It takes time to display the file, and how long it will take depends on the number of pixels of the file.
 - When a file is displayed as [[!]] on the thumbnail display, playback is not possible.
 - The time displayed may be different from the recording time and it may take time to display the thumbnail display when playing back still pictures recorded on another product.
 - When set to the picture playback mode, the power will not turn off even when the LCD monitor and the viewfinder are closed and retracted.

RAM -RW(VR) SD

Important:**The deleted scenes/files cannot be restored.**

- Scenes on DVD-RW discs in Video format and DVD-R/DVD-R DL discs cannot be deleted.

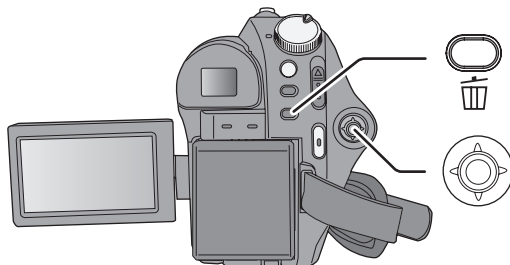

- ◇ Deleting motion picture scenes:

Rotate the mode dial to select .

- ◇ Deleting still picture files:

Rotate the mode dial to select .

- To delete an unwanted part of a scene, divide the scene first, and then delete the unnecessary part. (→ 57)

Deleting scenes/files one at a time

- 1 Press the  button during playback.**

- 2 When the confirmation message appears Select [YES], then press the joystick.**

Deleting multiple scenes/files

- 1 Press the  button in the thumbnail display.**

- 2 Select [SELECT] or [ALL] and press the joystick.**

- When [ALL] is selected, the following scenes/files will be deleted. Proceed to step 5.
 - All the scenes on the disc (When a date is selected, all scenes on the selected date)
 - All the files on the SD card except the locked files

3 (Only when [SELECT] is selected in step 2)
Select the scene/file to be deleted, then press the joystick.

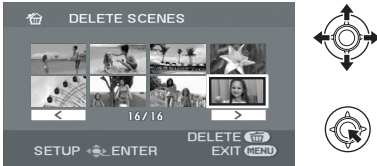

The selected scene/file is encircled by a red frame.

- To unselect the scene/file, press the joystick again.
- Up to 50 scenes/files can be selected to be deleted.

4 (Only when [SELECT] is selected in step 2)
Press the  button.

5 When the confirmation message appears
Select [YES], then press the joystick.

(Only when [SELECT] is selected in step 2)
To continue deleting other scenes/files
Repeat steps 3 to 5.

To complete editing
Press the MENU button.

-
- You can also delete scenes/files by the menu. Select [EDIT SCENE] or [PHOTO SETUP] → [DELETE].
 - In case of [ALL], the deletion may take time if there are many scenes/files.

■ Notes for deleting scenes/files

- Do not turn off this unit while deleting.
- When you delete scenes/files, use a battery with sufficient battery power or use the AC adaptor.
- It may not be possible to delete scenes that have been divided to approximately 1 second or less. Combine the divided scenes, and then delete them.
- Do not remove the SD card while deleting.
- If files conforming to DCF standard are deleted, all the data related to the files will be deleted.
- When deleting still picture files recorded on an SD card by other products, a still picture file (other than JPEG) that cannot be played back on this unit may be erased.

RAM -RW(VR)

◇ Rotate the mode dial to select .

Function	Operating method
<p>Dividing a scene</p> <p>This is for dividing a scene into two. To delete an unnecessary portion of a scene, first divide the scene and then delete the unnecessary portion.</p>	<ol style="list-style-type: none"> 1 Select the menu. (→ 26) [EDIT SCENE] → [DIVIDE] → [YES] 2 Select the scene to be divided, then press the joystick. <div data-bbox="525 573 817 735" data-label="Image"> </div> 3 When you reach the area where you want to divide the scene Select [] with the joystick. <div data-bbox="525 837 817 1000" data-label="Image"> </div> <ul style="list-style-type: none"> • Move the joystick left or right to fast forward/rewind playback. • Using slow-motion playback or frame-by-frame playback makes it easy to search for the point where you want to divide the scene. (→ 51) 4 When the confirmation message appears Select [YES], then press the joystick. <hr/> <p><i>To continue dividing other scenes</i> Repeat steps 2 to 4.</p> <p><i>To complete editing</i> Press the MENU button.</p>

Combining scenes

This function is only for combining two consecutive scenes into one.

- If you wish to combine scenes that are not next to each other or scenes with different recording dates, first create a playlist and then combine the scenes on the playlist. (→ 59, 61)

- 1** Select the menu. (→ 26)
[EDIT SCENE] → [COMBINE] → [YES]
- 2** Select the first scene of the two consecutive scenes to be combined, then press the joystick.



- 3** When the confirmation message appears
Select [YES], then press the joystick.

To continue combining other scenes

Repeat steps 2 to 3.

To complete editing

Press the MENU button.

RAM -RW(VR)

You can create a playlist by gathering your favourite recorded scenes.

Since the playlist is not created by copying data, playlists consume a very small amount of disc space.

- When you create or delete playlists, the original scenes will not be modified. Editing scenes on a playlist will not affect the original scenes.

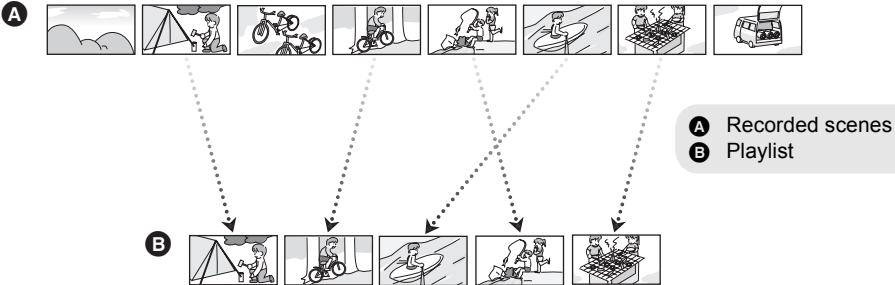

- The maximum number of playlists on one side of a disc: 99
The maximum number of playlist scenes on one side of a disc: 999
- If original scenes are deleted, the portion of playlists created with these scenes is also deleted.

Creating a new playlist

◇ Rotate the mode dial to select .

1 Select **[PL]** (PLAYLIST), then press the joystick.

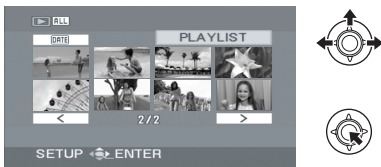

2 Select **[CREATE]**, then press the joystick.

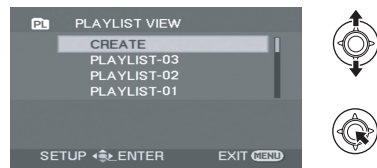

3 Select the scene to be added to the playlist, then press the joystick.

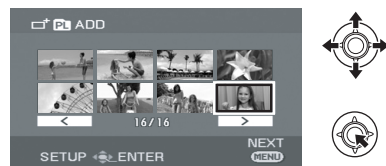

The selected scene is encircled by a red frame.

- To unselect the scene, press the joystick again.
- Up to 50 scenes can be selected and added.
- The scenes are registered in the playlist in the order that they were selected.

4 Press the MENU button.

- 5 When the confirmation message appears **Select [YES], then press the joystick.**

Editing a playlist

Editing scenes on a playlist will not affect the original scenes.

◇ Rotate the mode dial to select .

- 1 Select  (PLAYLIST), then press the joystick.



- 2 Select the playlist to be edited, then press the joystick.

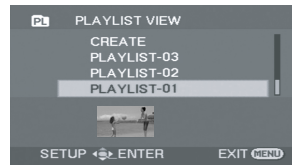

Function	Operating method
<p>Deleting scenes</p>	<p>The method for deleting playlist scenes is the same as for "Deleting scenes/files". (→ 55)</p> <ul style="list-style-type: none"> • If you delete scenes on a playlist, it will not affect the original scenes. • When [ALL] is selected, the selected playlist will be deleted. • You can also delete playlist scenes by the menu. Select [EDIT] → [DELETE]. • Deleting scenes on a playlist will not increase the remaining capacity for recording. • The playlist itself is deleted if you delete all the scenes in it. • When a playlist is deleted, the number of each subsequent playlist decreases by one.
<p>Adding scenes to playlist</p> <p>Scenes can be added to the created playlist.</p>	<p>Select the menu. (→ 26) [EDIT] → [ADD] → [YES]</p> <p>The following steps are the same as step 3 to 5 in "Creating a new playlist". (→ 59)</p>

Function	Operating method
----------	------------------

Moving scenes within a playlist

It is possible to change the sequence of scenes in the playlist by moving them to another position.

- 1 Select the menu. (→ 26)**
[EDIT] → [MOVE] → [YES]
- 2 Select the scene to be moved, then press the joystick.**

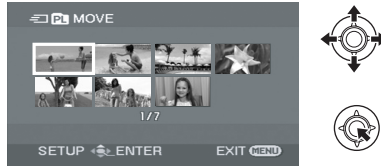

The selected scene is encircled by a red frame, and the position to insert is shown by a yellow bar.

- 3 Select the position to insert the scene, then press the joystick.**



To continue moving other scenes in the playlist

Repeat steps 2 to 3.

To complete editing

Press the MENU button.

Dividing a scene

This is for dividing a scene into two.

- Select the menu. (→ 26)**
[EDIT] → [DIVIDE] → [YES]

The following steps are the same as step 2 to 4 in "Dividing a scene" for "Editing scenes". (→ 57)





Combining scenes

This function is only for combining two consecutive scenes into one.

- Select the menu. (→ 26)**
[EDIT] → [COMBINE] → [YES]

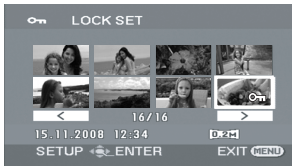
The following steps are the same as step 2 to 3 in "Combining scenes" for "Editing scenes". (→ 58)

- ◇ Rotate the mode dial to select .

Function	Operating method
<p>Locking still pictures</p> <p>This is for preventing still picture files from being deleted by mistake. (However even if you lock some files on an SD card, formatting the card will delete all the files.)</p>	<ol style="list-style-type: none"> 1 Select the menu. (→ 26) [PHOTO SETUP] → [LOCK SET] → [YES] 2 Select the file to be protected, then press the joystick. <div style="display: flex; align-items: center; justify-content: center;">  <div style="margin-left: 20px;">   </div> </div> <p>[] appears and the selected file is locked.</p> <ul style="list-style-type: none"> ● Press the joystick again to release the lock setting. ● You can also select multiple files in succession. <hr/> <p>To complete the settings Press the MENU button.</p>

DPOF setting

This is for writing the print data on selected still pictures.

■ What is DPOF?

DPOF (Digital Print Order Format) is a format which allows the user of a digital camera to define which captured images on the SD card are to be printed, together with information on the number of copies they wish to print. (Please note: Not all commercial printing services support this feature at this time.)

- 1 Select the menu. (→ 26)
[PHOTO SETUP] → [DPOF SET] → [SET]
- 2 Select the file to be set, then press the joystick.



- 3 Select the number of prints, then press the joystick.

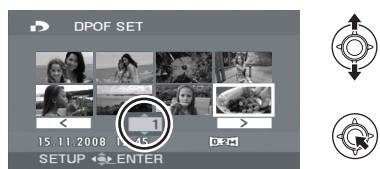

- To cancel the setting, set the number of prints to [0].
- You can also select multiple files in succession.

To complete the settings

Press the MENU button.

To cancel all DPOF settings

Select [PHOTO SETUP] → [DPOF SET] → [CANCEL ALL].

- The DPOF setting can be established for up to 999 files.
- DPOF setting made on other devices may not be recognised by this unit. Please perform the DPOF settings on this unit.
- You cannot add the recording date to pictures to be printed with the DPOF settings.

-RW(VR) -RW(V) -R -R DL

Allows discs to be played on other devices.

If you insert a DVD-RW or a DVD-R/DVD-R DL disc recorded in this unit (that has not been finalized) into another device such as DVD recorder, PC, etc., the disc may become unusable. Be sure to finalize the disc on this unit before inserting it in other devices.

DVD-RAM:

- It is not necessary to finalize DVD-RAM disc.

DVD-RW (VR format):

- After finalization, DVD-RW (VR format) discs can be recorded and edited in the same way as DVD-RW (VR format) discs before finalization.
- After finalizing a DVD-RW (VR format) disc once, it will not be finalized again. (Even if you record or edit a DVD-RW (VR format) disc, it is not necessary to finalize it again.)

DVD-RW (Video format), DVD-R, DVD-R DL:

- After finalizing, the disc becomes play only, and you can no longer record.
- When you un-finalize a DVD-RW (Video format) disc, the disc can be used for recording again. (→ 65)

◇ **Rotate the mode dial to select** .

1 Connect this unit to the AC adaptor.

- Finalization cannot be executed when using a battery. If the power supply stops while finalizing, the finalization will fail and the data may be damaged. Use the AC adaptor.

2 Select the menu. (→ 26)

[DISC SETUP] → [FINALIZE] → [YES]

3 When the confirmation message appears Select [YES], then press the joystick.

When finalizing a DVD-RW (Video format) or DVD-R/DVD-R DL disc, a top menu is created.

- When finalizing is complete, press the MENU button to exit the message screen.
- Do not finalize a disc recorded on this unit using any other device.
- When using a double sided disc, finalize each side.

- The top menu created when finalizing does not appear on this unit. It appears when the disc is played back on other devices.
- The time it takes to finalize a disc varies. The shorter the recording content on the disc, the longer it will take to finalize the disc.
- Do not shake, bump or expose this unit to heat while finalizing, the finalization will fail and the disc may become unplayable on other devices.
- If the power supply stops while finalizing, the finalization will fail and the disc may become unplayable on other devices even if disc repair is carried out.

Un-finalizing a DVD-RW disc

-RW(V)

This is for un-finalizing a DVD-RW (Video format) disc so that it can be used for recording.

◇ Rotate the mode dial to select .

1 Select the menu. (→ 26)

[DISC SETUP] → [UN-FINALIZE] →
[YES]

2 When the confirmation message appears Select [YES], then press the joystick.

- When un-finalizing is complete, press the MENU button to exit the message screen.
- Discs other than DVD-RW (Video format) discs cannot be un-finalized.
- When you un-finalize the disc, use a battery with sufficient battery power or the AC adaptor.

Protecting a disc/disc information

Protecting a disc

RAM -RW(VR)

This is for preventing recorded contents from being deleted or edited by mistake. Further recording and editing is not possible on protected discs until the protection is released.

◇ Rotate the mode dial to select .

1 Select the menu. (→ 26)

[DISC SETUP] → [DISC PROTECT]

2 When the confirmation message appears **Select [YES], then press the joystick.**

To release disc protection



Select [DISC SETUP] → [DISC PROTECT] again.

- If the disc has been protected on another device, it may not be possible to release the protection on this unit. In this case, release the protection on the device that you used to protect it.

Displaying disc information

RAM -RW(VR) -RW(V) -R -R DL

Information such as the number of recorded scenes, the remaining space and whether or not the disc is finalized or protected is displayed.

◇ Rotate the mode dial to select  or .

Select the menu. (→ 26)

[DISC SETUP] → [INFORMATION] → [YES]

To exit the information screen



Press the MENU button.

Formatting a disc

RAM **-RW(VR)** **-RW(V)**

This is for initializing discs.

Please be aware that if a disc is formatted, then all the data recorded on the disc will be erased.

◇ Rotate the mode dial to select  or .

1 Select the menu. (→ 26)

[DISC SETUP] → [FORMAT DISC] → [YES]

- When formatting a DVD-RAM disc, skip to step 3.

2 (When formatting a DVD-RW disc only)
Select format type (→ 18), then press the joystick.

3 When the confirmation message appears
Select [YES], then press the joystick.

- When formatting is complete, press the MENU button to exit the message screen.

- When using a double sided disc, format each side.
- It may not be possible to format a disc that is scratched or dirty. Such discs cannot be used.
- Do not turn this unit off while formatting.
- When you format the disc, use a battery with sufficient battery power or the AC adaptor.

Formatting a DVD-RAM disc:

- We recommend formatting discs on this unit. If formatting on a PC, use the supplied software. For more details, refer to the operating instructions of the software.

Formatting a DVD-RW disc:

- Format on this unit.

Formatting an SD card

SD

This is for initializing SD cards.

Please be aware that if an SD card is formatted, then all the data recorded on the card will be erased. Back up important data on a PC, etc.

◇ Rotate the mode dial to select  or .

1 Select the menu. (→ 26)

[SETUP] → [FORMAT CARD] → [YES]

2 When the confirmation message appears
Select [YES], then press the joystick.

- When formatting is complete, press the MENU button to exit the message screen.

- Use this unit to format SD cards. If an SD card is formatted on other products (such as a PC), the time spent for recording may become longer and you may not be able to use the SD card.
- Depending on the type of SD card being used, it may take time to format.
- During formatting, do not turn this unit off.
- When you format the SD card, use a battery with sufficient battery power or the AC adaptor.
- Do not remove the SD card while formatting.

RAM -RW(VR) -RW(V) -R -R DL SD

The motion pictures and still pictures recorded by this unit can be played back on a TV.

- Use the AC adaptor to free you from worrying about the battery running down.

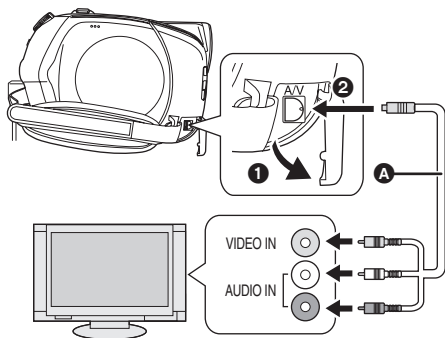

- A** AV cable (supplied)
- Insert the plugs as far as they will go.
 - Do not use any other AV cables except the supplied one.
 - Select the video input on the TV that this unit is connected to.

1 Connect this unit and a TV.

2 Turn on this unit, then rotate the mode dial to select or .

3 Start playback on this unit.

■ If the image or audio from this unit does not appear on the TV

- Check the connections.
- Check that the plugs are inserted as far as they go.
- Check the TV's input setting (input switch). (For more information, please read the operating instructions for the TV.)

■ To watch images with a 16:9 aspect ratio on a regular TV (4:3)

If the images are squeezed horizontally on a TV with a 4:3 aspect ratio, change the menu setting to play back the pictures in the original aspect ratio.

- If the images are not displayed correctly on a wide-screen TV, adjust the aspect setting on the TV. (Refer to the operating instructions of the TV for details.)

Select the menu. (→ 26)

[SETUP] → [TV ASPECT] → [4:3]

Example of images with a 16:9 aspect ratio on a regular TV (4:3)

[TV ASPECT] setting	
[16:9]	[4:3]

- This function's default setting is [16:9].
- Depending on the TV setting, the pictures may not be displayed correctly. For more information, please read the operating instructions of your TV.

RAM -RW(VR) -RW(V) -R -R DL

- Do not insert a DVD-RW or a DVD-R/DVD-R DL disc recorded in this unit (that has not been finalized) into another device such as DVD recorder, DVD player, PC, etc. as the disc may become unusable.
- If you insert a DVD-RW disc recorded in this unit (that has not been finalized) into another device such as DVD recorder, PC, etc., a format message may appear. Do not format the disc as all the important data recorded on the disc will be erased and cannot be recovered.

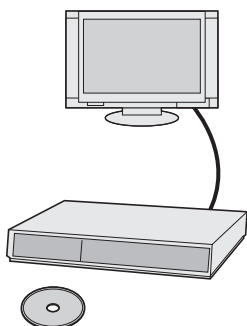

Playback on DVD recorder, DVD player, PC etc.

- When playing back a disc on a DVD recorder/player, place the device so that the disc lies flat.

1 For a DVD-RW or a DVD-R/DVD-R DL disc
Finalize the disc on this unit.
(→ 64)

2 Insert the disc in the playback device and then play it back.

- Playback is only possible on devices that support 8 cm DVD-RAM, DVD-RW (VR format), or DVD-R DL discs. Refer to the operating instructions of the playback device.
RAM -RW(VR) -R DL
- Playback is possible on devices that support 8 cm DVD-Video, but playback on all DVD players is not guaranteed. **-RW(V) -R**

Dubbing recordings onto a DVD recorder's hard disk

- If you want to dub a disc that the DVD recorder is not compatible with, connect this unit and the DVD recorder with the AV cable and then dub the disc. (→ 70)

1 For a DVD-RW or a DVD-R/DVD-R DL disc
Finalize the disc on this unit.
(→ 64)

2 Insert the disc in the DVD recorder, then dub the contents onto the hard disk.

- For details, refer to the operating instructions of the DVD recorder.
- If your DVD recorder has an SD card slot, you can copy the still pictures recorded on the SD card to a disc or the hard drive.
- If you dub images recorded on a DVD-RW (Video format) or a DVD-R/DVD-R DL disc, the title name of the images after dubbing becomes the date they were dubbed.

If you dub images directly from the disc or with the AV cable and then play them back on a wide-screen TV, they may be squeezed horizontally. In this case, refer to the operating instructions of the device you are dubbing to or read the operating instructions of the wide-screen TV and set the aspect setting to 16:9 (Full).

RAM -RW(VR) -RW(V) -R -R DL

You can create a playlist by gathering the scenes you want to dub, then dub the scenes in this playlist only to other devices. (→ 59)

- Use the AC adaptor to free you from worrying about the battery running down.

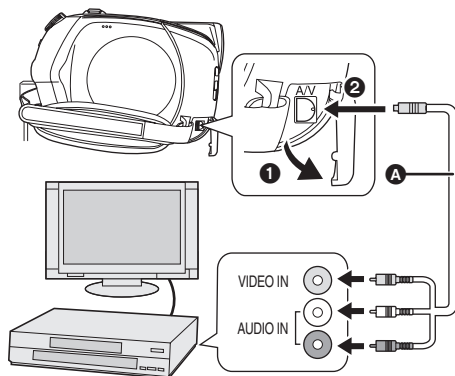

A AV cable (supplied)

- Insert the plugs as far as they will go.
- Do not use any other AV cables except the supplied one.
- Select the video input on the video device and TV that this unit and the video device are connected to.

1 Connect this unit and a video device.

2 Turn on this unit, then rotate the mode dial to select .

3 Start playback on this unit.
Then start recording on the connected device.

To stop dubbing

Stop recording on the connected device.
Then stop playback on this unit.

4

With a printer (PictBridge)

SD

To print pictures by directly connecting this unit to the printer, use a printer compatible with PictBridge. (Read the operating instructions for the printer.)

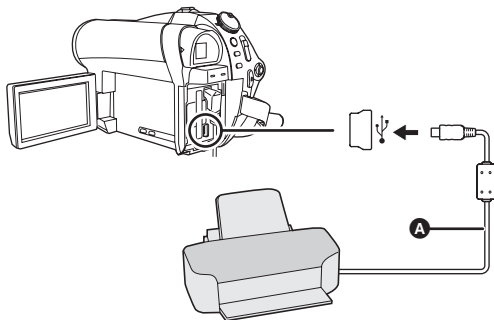

- A** USB cable (supplied)
- Insert the USB connectors as far as they will go.
- Do not use any other USB connection cables except the supplied one. (Operation is not guaranteed with any other USB cables.)

◇ Connect this unit to the AC adaptor and turn on the unit.

1 Connect this unit and a printer.

2 Select [PictBridge] and press the joystick.

The [PictBridge] indication appears on this unit's screen.

3 Select a file to be printed, then press the joystick.



4 Select the desired number of prints, then press the joystick.



- You can set up to 9 prints.
- To cancel the setting, set the number of prints to [0].
- Up to 8 files can be selected to be printed.

5 Press the MENU button to display the PictBridge menus.

6 Select the date print setting on [DATE PRINT], then press the joystick.

- If the printer is not capable of date printing, this setting is unavailable.

7 Select the paper size setting on [PAPER SIZE], then press the joystick.

[STANDARD]:

Size specific to the printer

[4x5 INCH]:

L size

[5x7 INCH]:

2L size

[4x6 INCH]:

Postcard size

[A4]:

A4 size

- You cannot set paper sizes not supported on the printer.

8 Select the layout setting on [PAGE LAYOUT], then press the joystick.

[STANDARD]:

Layout specific to the printer

[]:

No frame print

[]:

Frame print

- You cannot set page layouts not supported on the printer.

9 Select [PRINT] → [YES] and press the joystick.

- Exit PictBridge by disconnecting the USB cable after the pictures have been printed.

When you want to stop printing halfway

Move the joystick down.

A confirmation message appears. If [YES] is selected, the number of prints set is cancelled and the screen returns to step 3. If [NO] is selected, all the settings are kept and the screen returns to step 3.

-
- Avoid the following operations during printing. These operations disable proper printing.
 - Disconnecting the USB cable
 - Removing the SD card
 - Switching the mode dial
 - Turning off the power
 - Check the settings for the paper size, quality of print, etc. on the printer.

- The sides of pictures recorded in [] mode may be cut off. Check before printing (print preview).

When using a printer with a trimming or borderless printing function, cancel this function before printing. (Refer to the operating instructions of the printer for details.)

- When the unit is connected directly to the printer, the DPOF settings cannot be used.
- Connect the printer directly to this unit. Do not use a USB hub.

Preparation

Recording

Playback

With a PC

Others

- 74** Before using
- 78** Setup
- 83** Using software
- 84** Using a Macintosh

What you can do with a PC

When you have installed VideoCam Suite from the supplied CD-ROM and connected your PC to the unit, you can perform the operations described below.



- A** Play back images recorded by this unit on a PC.
- B** Copy images recorded by this unit onto the PC hard disk.
Select the desired images and create original DVD-Video discs.
- C** Edit (split, merge, or delete) images copied to a PC.
Create playlists.

-
- VideoCam Suite can handle images recorded with this unit or by using VideoCam Suite. Images created with other video cameras, DVD recorders, software and commercial DVD-Videos are not supported.
 - We cannot guarantee proper operation of this unit if you use software other than that supplied.

■ Adobe Reader

To view the installed operating instructions, Adobe Reader (Adobe Acrobat Reader) 5.0 or later is required.

If the Adobe Reader (Adobe Acrobat Reader) is not already installed on your PC, you can install it from the CD-ROM. Click the desired language in [Setup Menu], and follow the on-screen messages to install.

- The following system requirements are necessary in order to install Adobe Reader from the supplied CD-ROM.
 - Intel Pentium III or equivalent processor
 - Microsoft Windows 2000 Professional Service Pack 4, Microsoft Windows XP Home Edition Service Pack 2, Microsoft Windows XP Professional Service Pack 2, or Microsoft Windows Vista
 - 128 MB of RAM (256 MB recommended for complex forms or large documents)
 - Microsoft Internet Explorer 6.0 or 7.0, Firefox 1.5 or 2.0, Mozilla 1.7, AOL 9
- If the application cannot be installed under the system requirements listed above, execute Windows Update and then attempt to install the application again.

- A CD-ROM drive is necessary to install the supplied software applications.
- When 2 or more USB devices are connected to a PC, or when devices are connected through USB hubs or by using extension cables, proper operation is not guaranteed.
- Use the supplied USB cable when connecting to the PC. (Operation is not guaranteed with any other USB cables.)

■ VideoCam Suite 1.0

Personal computer	IBM PC/AT compatible personal computer
OS	Microsoft Windows 2000 Professional Service Pack 4 Microsoft Windows XP Home Edition Service Pack 2 Microsoft Windows XP Professional Service Pack 2 Microsoft Windows Vista Home Basic Microsoft Windows Vista Home Premium
CPU	Intel Pentium III 800 MHz or higher (Intel Pentium 4 1.8 GHz or higher recommended)
RAM	Windows Vista: 512 MB or more (1 GB or more recommended) Windows XP/2000: 256 MB or more
Display	High Colour (16 bit) or more (32 bit or more recommended) Desktop resolution of 1024×768 pixels or more Video card supporting DirectX 9.0c (supports overlay of DirectDraw)
Free hard disk space	DMA transfer effective at Ultra DMA/33 or more (Ultra DMA/100 or higher recommended) For installing the application: 150 MB or more When creating discs (DVD-Video): 5 GB or more for the work folder (10 GB or more in the case of dual layer discs) <ul style="list-style-type: none"> • If compression setting is enabled, errors may occur during recording. Please uncheck [Compress this drive and clear the disc area] in [Properties] on the hard disk drive.
Necessary software	DirectX 9.0c or later <ul style="list-style-type: none"> • If you install the software on a PC that is not compatible with DirectX 9.0c, the PC may not work properly. If you are unsure whether or not your PC is compatible, contact the maker of your PC. Adobe Acrobat Reader 5.0 or later or Adobe Reader 6.0 or later (required to display the operating instructions) <ul style="list-style-type: none"> • For Windows Vista, use Adobe Reader 8.0 or later.
Disc drive	A drive that supports recording on DVD-R/DVD-RW/DVD-RAM discs
Sound	DirectSound support
Interface	USB port [Hi-Speed USB (USB 2.0) is recommended]
Other requirements	Mouse or equivalent pointing device

- Even if the system requirements mentioned in these operating instructions are fulfilled, some personal computers cannot be used.
- Supplied CD-ROM is available for Windows only.
- This software is not compatible with Microsoft Windows 3.1, Windows 95, Windows 98/98SE, Windows Me and Windows NT.
- Operation on an upgraded OS is not guaranteed.
- Operation is not guaranteed on computers that are not PC/AT compatible.
- This software is not compatible with a multi-boot environment.
- This software is not compatible with a multi-CPU environment.
- Operation is not guaranteed on Microsoft Windows XP Media Center Edition, Tablet PC Edition, Windows Vista Business/Enterprise and 64 bit operation systems.
- Input is not supported in languages other than English, German, French, Italian, Spanish and Simplified Chinese.
- DirectX 9.0c will be installed automatically during installation of the supplied software.
- Operation cannot be guaranteed on all DVD drives.
- DVD discs authored with this software are not guaranteed to play in all DVD players.
- Depending upon the environment of your PC, if it does not support Hi-Speed USB (USB 2.0), for example, frame dropout may occur, the audio may be intermittent, or the software may run slowly when you play back recorded images.
- If your PC does not satisfy the above system requirements, an error may occur when writing data to disc.

■ SD card reader function (mass storage)

Personal computer	IBM PC/AT compatible personal computer
OS	Microsoft Windows 2000 Professional Service Pack 4 Microsoft Windows XP Home Edition Microsoft Windows XP Professional Microsoft Windows Vista Home Basic Microsoft Windows Vista Home Premium
CPU	Windows Vista: Intel Pentium III 1.0 GHz or higher Windows XP/2000: Intel Pentium II 300 MHz or higher
RAM	Windows Vista Home Basic: 512 MB or more Windows Vista Home Premium: 1 GB or more Windows XP/2000: 32 MB or more (64 MB or more recommended)
Interface	USB port

- The USB equipment operates with the driver installed as standard in the OS.

End User License Agreement

Before opening the CD-ROM package, please read the following.

You ("Licensee") are granted a license for the Software defined in this End User Software Agreement ("Agreement") on condition that you agree to the terms and conditions of this Agreement. If Licensee does not agree to the terms and conditions of this Agreement, promptly return the Software to Matsushita Electric Industrial Co., Ltd. ("Matsushita"), its distributors or dealers from which you made the purchase.

Article 1 License

Licensee is granted the right to use the software, including the information recorded or described on the CD-ROM, instruction manuals, and any other media provided to Licensee (collectively "Software"), but all applicable rights to patents, copyrights, trademarks and trade secrets in the Software are not transferred to Licensee.

Article 2 Use by a Third Party

Licensee may not use, copy, modify, transfer or allow any third party, whether free of charge or not, to use, copy or modify the Software, except as expressly provided for in this Agreement.

Article 3 Restrictions on Copying the Software

Licensee may make a single copy of the Software in whole or in part solely for back-up purposes.

Article 4 Computer

Licensee may only use the Software on a single computer at a single location.

Article 5 Reverse Engineering, Decompiling or Disassembly

Licensee may not reverse engineer, decompile, or disassemble the Software, except to the extent either of them is permitted under law or regulation of the country where Licensee resides. Matsushita, or its distributors or dealers will not be responsible for any defects in the Software or damage to Licensee caused by Licensee's reverse engineering, decompiling, or disassembly of the Software.

Article 6 Limitation of Liability

The Software is provided "AS-IS" without warranty of any kind, either expressed or implied, including, but not limited to, warranties of non-infringement, merchantability and/or fitness for a particular purpose. Further, Matsushita does not warrant that the operation of the Software will be uninterrupted or error free. Matsushita or any of its distributors or dealers will not be liable for any damage suffered by Licensee arising from or in connection with Licensee's use of the Software.

Article 7 Export Control

Licensee agrees not to export or re-export to any country the Software in any form without the appropriate export licenses under regulations of the country where Licensee resides, if necessary.

Article 8 Termination of License

The right granted to Licensee hereunder will be automatically terminated if Licensee violates any of the terms and conditions of this Agreement. Upon such automatic termination, Licensee must destroy the Software and related documentation together with all the copies thereof at Licensee's own expense.

When installing the software, log on to your PC as the Administrator (or with a user name with equivalent authorization) or with the user name for a standard user account. (If you do not have authorization to do this, consult your manager.)

- Before starting the installation, close any other software applications which are running.
- Do not perform any other operations on your PC while the software is being installed.

For Windows Vista:

If [User Account Control] dialogue appears, click [Continue].

Installing VideoCam Suite

1 Insert the CD-ROM into the PC.

The [Setup Menu] screen will appear.

- If the [Setup Menu] screen does not appear, double-click the CD-ROM drive icon in [My Computer (Computer)].

2 Click [VideoCam Suite 1.0].



3 Click [Next].

4 Select where the application is to be installed, then click [Next].



5 Select [Yes] or [No] to create shortcut.

6 Select the country or region where you live, then click [Next].

- If the country or region cannot be selected, select [PAL Area].

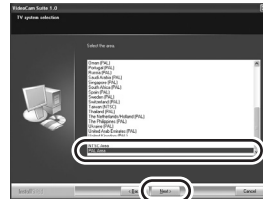

- When the confirmation message appears, click [Yes].

7 Click [Install] to start the installation process.



8 When installation is complete, some notes will appear. Check the contents, then close the window.

- 9** Select [Yes, I want to restart my computer now.], then click [Finish].

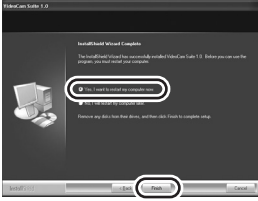

The PC must be rebooted for the application to work.

- Depending on the operating environment, you may be required to install DirectX 9.0c. If so, click [Yes], and install it. If you install the software on a PC that is not compatible with DirectX 9.0c, the PC may not work properly. If you are unsure whether or not your PC is compatible, contact the PC manufacturer.

Uninstalling the software

Follow the steps below to uninstall the software if it is no longer required.

■ For Windows Vista

- 1** Select [Start] → [Control Panel] → [Uninstall a program].

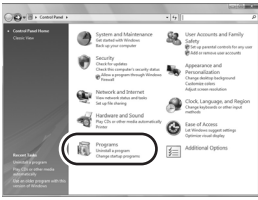

- 2** Select [VideoCam Suite 1.0], then click [Uninstall].

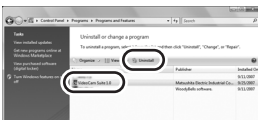

■ For Windows XP

- 1** Select [start] → [Control Panel] → [Add or Remove Programs].

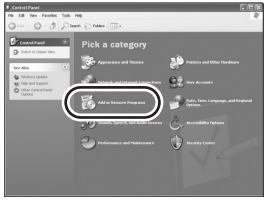

- 2** Select [VideoCam Suite 1.0], then click [Remove].



■ For Windows 2000

- 1** Select [Start] → [Settings] → [Control Panel] → [Add/Remove Programs].



- 2** Select [VideoCam Suite 1.0], then click [Change/Remove].



After the software is installed, the unit must be connected to the PC and be correctly recognised by the PC.

- Remove the supplied CD-ROM from your PC.
- **Be sure to finalize DVD-RW (VR format), DVD-RW (Video format) and DVD-R/DVD-R DL discs on this unit, before using them on the PC. Discs that have not been finalized will not be recognised by the PC.**

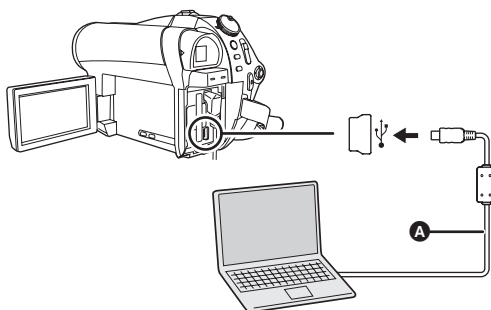

- A** USB cable (supplied)
- Insert the USB connectors as far as they will go.
 - Do not use any other USB connection cables except the supplied one. (Operation is not guaranteed with any other USB cables.)

◇ **Connect this unit to the AC adaptor.**

1 Insert a disc or SD card with recorded images in the unit, then turn on the unit.

2 Connect this unit and a PC.

The USB function selection screen will appear.

3 Select [PC CONNECT(DISC)] or [PC CONNECT(CARD)] and press the joystick.

This unit is automatically detected by the PC.

- **When the unit is connected to a PC, its power cannot be turned off. Disconnect the USB cable before turning this unit off. (→ 82)**
- If the unit is connected to a PC when the USB function is set to [PC CONNECT(DISC)], no image will appear on the LCD monitor or the viewfinder.
- When this unit is connected to a PC, you cannot use this unit's DISC EJECT lever to remove a disc. Use Windows Explorer to right-

click the drive icon for this unit and select [Eject].

- Do not disconnect the USB cable or AC adaptor while the access lamp is on or SD card access icon () appears on the LCD monitor. Doing so may damage the data on the disc or SD card.
- The disc and SD card cannot be accessed simultaneously.
- It may be necessary to reboot the PC after connecting this unit to it for the first time.

About the PC display

When the unit is connected to a PC, it is recognised as an external drive.

- Depending on the operating environment of the PC, the shape of the drive icon and the drive name will differ. These illustrations are examples.

■ When accessing the disc



Optical disc drive is displayed in [My Computer (Computer)].

Folder structure* **RAM** **-RW(VR)**:

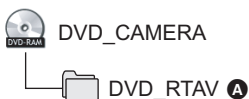

A VR format motion pictures are stored.

* This is not displayed in Windows 2000.

Folder structure **-RW(V)** **-R** **-R DL**:

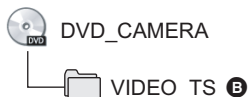

B Video format motion pictures are stored.

Do not move or change the name of the folders and files recorded on this unit with Windows Explorer etc.

■ When accessing the SD card

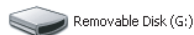

[Removable Disk] is displayed in [My Computer (Computer)].

Folder structure **SD**:

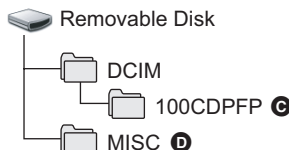

C JPEG format still pictures (IMGA0001.JPG etc.) are stored.

• Up to 999 files can be recorded in the [100CDPFP] or other such folder.

D The DPOF setting files are stored.

■ Copying still pictures on PC

SD card reader function (mass storage)

When the unit is connected to a PC and the SD card can be used as an external drive, still pictures on the card can be copied to the PC with Windows Explorer or other programs.

- 1 Double click the folder that contains the files on the removable disk ([100CDPFP] etc.).
- 2 Drag and drop the files onto the destination folder (on the PC hard disk).

- Do not delete the SD card's folders. Doing so may make the SD card unusable in this unit.
- Always use this unit to format SD cards.

To disconnect USB cable safely

1 Double click the () icon in task tray.

Hardware disconnect dialogue appears.

- Depending on your PC's settings, this icon may not be displayed.

2 Select [USB Mass Storage Device] and click [Stop].

3 Verify [MATSHITA DVD-RAM CAM-DD4 USB Device] or [MATSHITA DVD CAM-SD USB Device] is selected and click [OK].

Click [Close], and you can safely disconnect the cable.

Starting VideoCam Suite

For Windows Vista:

- When using VideoCam Suite, log on to your PC as Administrator (or with a login name equally authorized) or with the user name for a standard user account. If you log on with a user name for a guest user account, the software cannot be used.

For Windows XP/2000:

- When using VideoCam Suite, log on to your PC as Administrator (or with a login name equally authorized). If you log on with a login name other than Administrator, the software cannot be used.

Select [start] → [All Programs (Programs)] → [Panasonic] → [VideoCam Suite 1.0] → [VideoCam Suite].



Refer to the operating instructions of the software (PDF file) for details on how to use it.

- When using VideoCam Suite, data can only be written to a DVD-RAM disc using this unit. This unit is only capable of reading other types of discs.

Take care that the temperature of the unit, when connected to a PC, does not rise excessively (reference for usage: approx. 30 minutes at about 30 °C).

Reading the operating instructions of the software

- You will need Adobe Reader to read the PDF operating instructions. (→ 74)

Select [start] → [All Programs (Programs)] → [Panasonic] → [VideoCam Suite 1.0] → [Manual].

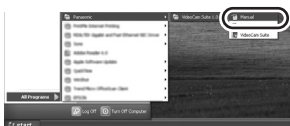

■ Operating environment for the SD card reader function (mass storage)

Personal computer	Macintosh
OS	Mac OS X v10.4
CPU	PowerPC G5 (1.8 GHz or higher) Intel Core Duo Intel Core Solo
RAM	64 MB or more
Interface	USB port

- Even if the system requirements mentioned in these operating instructions are fulfilled, some personal computers cannot be used.
- The USB equipment operates with the driver installed as standard in the OS.
- Supplied CD-ROM is available for Windows only.

■ Copying still pictures on PC

1 Connect this unit to a PC via the supplied USB cable.

- The USB function selection screen will appear.

2 Select [PC CONNECT(CARD)], then press the joystick.

3 Double-click [NO NAME] icon displayed on the desktop.

- Files are stored in [100CDPFP] folder etc. in the [DCIM] folder.

4 Drag and drop the files onto the destination folder (on the PC hard disk).

■ To disconnect USB cable safely

Drag [NO NAME] icon to the [Trash], and then disconnect the USB cable.

Preparation

Recording

Playback

With a PC

Others

86 Indications

90 Helpful hints

■ Recording indications

Motion picture recording

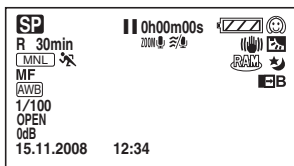

Still picture recording

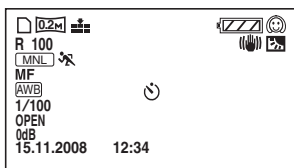

Remaining battery power
(→ 17)

R 30min Remaining time for recording

0h00m00s Elapsed recording time

15.11.2008 Date/time indication (→ 29)
12:34

●/|| (Red) Recording/writing to a disc
(→ 33)

|| (Green) Recording pause (→ 33)

16:9 Aspect ratio 16:9 (→ 44)

AUTO Auto mode (→ 32)

MNL Manual mode (→ 45)

MF Manual focus (→ 46)

2× Zoom magnification indication
(→ 37)

☀ Back light mode (→ 42)

⦶ Image stabilizer (→ 39)

1/100 Shutter speed (→ 48)

OPEN, F2.0 F number (→ 48)

0dB Gain value (→ 48)

☺ Soft skin mode (→ 42)

☐W, ☐B Fade (White), Fade (Black)
(→ 42)

☀ Colour night view function
(→ 42)

ZOOM Zoom microphone (→ 38)

⦶ Wind noise reduction (→ 44)

XP, SP, LP Motion picture recording mode
(→ 34)

Scene mode (→ 46)

Sports mode

Portrait mode

Low light mode

Spotlight mode

Surf & snow mode

White balance (→ 47)

AWB Auto white balance

☀ Indoor mode (recording under
incandescent lamp)

☀ Outdoor mode

☀ Manual adjustment mode

Disc type (→ 18)

RAM DVD-RAM

VR DVD-RW (VR format)

Video DVD-RW (Video format)

Video DVD-RW (unformatted)

R DVD-R

DL DVD-R DL

☺ Self-Timer recording (→ 43)

Number of recording pixels for
still pictures (→ 36)

0.3M 640×480

0.2M 640×360

☐ (White) SD card can be recorded

☐ (Green) Recognising the SD card

☐ (Red) Recording/accessing the SD
card

☐, ☐ Still picture quality (→ 36)

R 100 Remaining number of still
pictures

■ Playback indications

Motion picture playback



Still picture playback

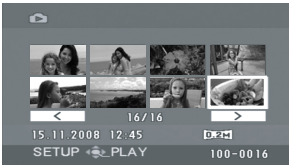

	Playback (→ 50)
	Pause (→ 50)
	Fast forward/rewind (→ 51)
	Last/first scene paused
	Skip playback (→ 50)
	Slow-motion playback (→ 51)
	Frame-by-frame playback (→ 51)
0h00m00s	Motion picture playback time
	Play mode (→ 52) All scenes on the disc displayed
	Scenes recorded on the selected date displayed
	Scenes in the selected playlist displayed
	Motion picture recording mode (→ 34)
No.10	Scene number
	Volume adjustment (→ 51)
R	Resume playback (→ 52)
	Contents that have been protected on another device Locked still pictures (→ 62)
100-0001	Still picture folder/file number display

	When a printer compatible with PictBridge is connected (→ 71)
	Accessing the SD card (When connected to a PC)
	DPOF already set (to more than 1) (→ 63)
	Number of recording pixels for still pictures (→ 36) 640×480
	640×360
The picture size is not displayed for still pictures recorded with other products that have different picture sizes from the sizes shown above.	

■ Confirmatory indications

	The built-in battery is low. (→ 29)
	The warning/alarm indication appears when LCD monitor is rotated towards the lens side. Return the direction of the LCD monitor to normal position and check the warning/alarm indication.
	No disc is inserted.
	Unusable disc
	No SD card is inserted. Unusable card

CAN NOT READ THIS DISC. PLEASE CHECK FOR SCRATCHES OR STAINS ON DISC.

The disc is scratched or dirty. Eject the disc and clean it. (→ 20) If there are scratches on the disc, use a new disc.

INCOMPATIBLE DISC.

You inserted an incompatible disc (copy-protected discs, etc.).

PLEASE CHECK THE DISC.

You inserted a disc that cannot be read on this unit (a disc recorded in an incompatible data format etc.).

FOR BEST PERFORMANCE PANASONIC DISC IS RECOMMENDED.

You inserted a disc that does not meet the DVD standard for quality and performance so you may not be able to record normally. Refer to the following support site for information about discs that have been confirmed as compatible by Panasonic.

http://panasonic.jp/support/global/cs/e_cam (This website is in English only.)

CANNOT RECORD. (THIS DISC IS FINALIZED)

A finalized DVD-RW (Video format) or DVD-R/DVD-R DL disc has been inserted. After finalizing, the discs become play only and cannot record. If you un-finalize a DVD-RW (Video format) disc, it can be used for recording. (→ 65)

FINALIZE THE DISC FOR PLAYBACK ON OTHER DEVICES.

If you insert a DVD-RW or a DVD-R/DVD-R DL disc recorded in this unit (that has not been finalized) into another device such as DVD recorder, PC, etc., the disc may become unusable. Be sure to finalize the disc on this unit before inserting it in other devices.

CHECK CARD.

This card is not compatible or it cannot be recognised by the unit.

THIS BATTERY CANNOT BE USED.

Use a battery that is compatible with this unit. (→ 14)

You are attempting to connect an AC adaptor not compatible with this unit. Use the supplied AC adaptor. (→ 17)

If using a Panasonic battery compatible with this unit (→ 14), remove the battery and then insert it again. If the message appears even after repeating this several times, this unit needs repair. Detach the power and consult the dealer who you purchased this unit from. Do not attempt to repair it by yourself.

PUSH THE RESET SWITCH.**CHECK THE DISC AFTER PUSHING THE RESET SWITCH TO REPAIR IT.**

An irregularity in the unit has been detected. Press the RESET button to restart the unit. (→ 95)

EXIT THE MENU THEN CHANGE TO MANUAL MODE.**CANCEL NIGHT VIEW MODE**

You are attempting to use a function that cannot be used simultaneously.

CANNOT SET.

With DVD-RW (Video format) and DVD-R/DVD-R DL discs, if the number of dates displayed when **DATE** (BY DATE) is selected is 99, you cannot change the aspect ratio from 16:9 to 4:3 and vice versa.

DISCONNECT USB CABLE.

The unit cannot correctly establish the connection to the PC or printer. Disconnect and reconnect the USB cable and then select the desired USB function again.

CANNOT OPERATE WHILE USB CONNECTED.

The unit's power cannot be turned off when the unit is connected to the PC.

About recovery

It is possible that the system cannot complete writing of a file normally when, for example, power is turned off for some reason during recording or editing.

If faulty management information is found when a disc is accessed, the following message may appear. Be sure to follow the messages. (Repairing may take time depending on the error.)

NOW REPAIRING DATA. DO NOT SHAKE THE UNIT.

- When you repair the disc, use a battery with sufficient battery power or the AC adaptor. Even if the power is turned off without repairing the disc, you can repair the disc when you turn the power on again.
- Depending on the condition of the data, it may not be possible to completely repair the data.
- Do not repair a disc that has been recorded on another device. This may cause the loss of data or the disc.

Functions that cannot be used simultaneously

Some functions in this unit are disabled or cannot be selected due to the unit's specifications. The table below shows examples of functions restricted by various conditions.

Functions	Conditions which disable the functions
Digital zoom	<ul style="list-style-type: none"> • In picture recording mode
Fade	
Colour night view	<ul style="list-style-type: none"> • While recording to a disc (Cannot set or cancel) • In picture recording mode
Backlight compensation	<ul style="list-style-type: none"> • When the Colour night view function is used • When the iris/gain is set
Soft skin mode (Set and cancel)	<ul style="list-style-type: none"> • While recording to a disc
Help mode	
Scene mode	<ul style="list-style-type: none"> • In auto mode • When the Colour night view function is used
Change of white balance	<ul style="list-style-type: none"> • When digital zoom is used • When the Colour night view function is used
Adjusting the shutter speed, iris/gain	<ul style="list-style-type: none"> • When the Colour night view function is used • When the scene mode is used

? What kind of discs can be used?



DVD-RAM, DVD-RW, DVD-R and DVD-R DL discs can be used if they are 8 cm non-cartridge discs. (→ 18)

? Can discs with a cartridge be used?



They can be used if the cartridge is removed.

? Can double sided discs be used?



They can be used.
However you cannot record or play continuously from one side of the disc to the other.
You will need to eject the disc and turn it over.

? Can I record continuously from one side of the disc to the other on a double sided disc?



You cannot record continuously from one side of the disc to the other. The recording time indicated on the disc package is the total time for both sides. You will need to eject the disc and turn it over to record on both sides.

? Is playback possible on a DVD player?



By finalizing a DVD-RW (VR format/Video format) or a DVD-R/DVD-R DL disc in this unit, it can be played back on a DVD player.
To playback a DVD-RAM, DVD-RW (VR format), or DVD-R DL disc, you will need a DVD recorder or a DVD player that supports DVD-RAM, DVD-RW (VR format) or DVD-R DL disc. Refer to the operating instructions of the DVD recorder or DVD player.

Problem	Check points
<p>This unit cannot be turned on.</p> <p>This unit does not stay on long enough.</p> <p>Battery runs down quickly.</p>	<ul style="list-style-type: none"> • Charge the battery using the AC adaptor. (→ 14) • The battery protection circuit may have operated. Attach the battery to the AC adaptor for 5 to 10 seconds. If the unit still cannot be used, the battery is faulty. • Make sure the LCD monitor is opened or the viewfinder extended. • The battery is affected by ambient temperature. In cold places, the battery using time becomes shorter. • The battery has a limited life. If the operating time is still too short even after the battery is fully charged, the battery has worn out and needs to be replaced.
<p>This unit is turned off automatically.</p>	<ul style="list-style-type: none"> • If you do not use the unit for approximately 5 minutes, the power is automatically turned off to conserve battery life. To resume recording, turn the power back on. The power will not turn off automatically when the power save function (→ 27) is set to [OFF].
<p>This unit cannot be operated though it is turned on.</p> <p>This unit does not operate normally.</p>	<ul style="list-style-type: none"> • The unit cannot be operated unless you open the LCD monitor or extend the viewfinder. • Press the RESET button. (→ 95) If normal conditions are not restored yet, remove the battery or AC adaptor, wait about 1 minute and then reconnect the battery or AC adaptor. Then about 1 minute later, turn on the power again. (Performing the above operation when the access lamp is on may destroy the data on the disc or SD card.)
<p>A clicking sound is heard when the power is turned off.</p>	<ul style="list-style-type: none"> • This is the sound of the lens moving and is not a malfunction.
<p>The screen has changed suddenly. (Demo mode is on.)</p>	<ul style="list-style-type: none"> • If you set [DEMO MODE] to [ON] without inserting a disc or an SD card in video recording mode or picture recording mode, the unit is automatically set to the demonstration mode for introducing its functions. Normally this should be set to [OFF]. (→ 28)

Problem

Check points

The DISC EJECT lever does not work.



- The disc cover will not open unless the unit is powered. Connect a charged battery or AC adaptor.
- The DISC EJECT lever does not work after the unit is connected to the PC. Use Windows Explorer to right-click the drive icon and select [Eject]. Or select [Eject] from the software's menu.

The disc cannot be read.



- If there are fingerprints or dirt on the disc, wipe them off. (→ 20)



A function indication such as the remaining time indication or the elapsed time indication is not shown.



- If you set [SETUP] → [DISPLAY] → [OFF], all indications other than warnings and date are not displayed.

Recording does not start, although power is supplied to the unit and the disc or SD card is correctly inserted.



- Rotate the mode dial to select  or .
- If the DVD-RAM or the DVD-RW (VR format) disc is write-protected, release the protection. (→ 66) If the DVD-RAM or DVD-RW (VR format) disc was protected on another device, use the same device to release the protection.
- Data cannot be recorded to finalized DVD-RW (Video format) and DVD-R/DVD-R DL discs. If you un-finalize a DVD-RW (Video format) disc, it can be used for recording. (→ 65)
- No recording is possible while the SD card's write protect switch is set to LOCK. (→ 22)
- If the disc or SD card has no more available memory, free up some memory by deleting unnecessary scenes (→ 55) or use a new disc or SD card.
- If the cover of the disc compartment is open, this unit may not operate normally. Close the disc cover.



Recording starts but stops immediately.
The playback picture breaks up for a moment.



- The disc is scratched or dirty. Eject the disc and clean it. (→ 20) If there are scratches on the disc, use a new disc.
- The unit is hot. Follow the messages on the display. To use the unit again, turn the unit off and leave it for a while.

Recorded still pictures are not clear.



- If you try to record small or finely detailed objects with [PICT.QUALITY] set at [], the images may break up into a mosaic-like pattern. Record with [PICT.QUALITY] set at [] instead. (→ 36)

Problem	Check points
<p>Auto focus function does not work.</p>	<ul style="list-style-type: none"> ● Press the AUTO button. ● There are some recording subjects and surroundings for which the auto focus does not operate correctly. (→ 100) If so, use the manual focus mode to adjust the focus. (→ 46)
<p>“CHECK THE LENS COVER.” is displayed.</p>	<ul style="list-style-type: none"> ● Open the lens cover before turning the unit on. ● This message may appear if you try to record in extremely dark places.
<p>Sound is not played back from the built-in speaker of this unit.</p>	<ul style="list-style-type: none"> ● During playback, move the volume lever to display the volume indication and adjust it. (→ 51)
<p>Although this unit is correctly connected to a TV, playback images cannot be seen.</p> <p>The playback images are squeezed horizontally.</p>	<ul style="list-style-type: none"> ● Please read the operating instructions of your TV and select the video input that this unit is connected to. ● Change the setting to match the aspect ratio of the TV. (→ 68)
<p>Scenes or files cannot be deleted or edited.</p>	<ul style="list-style-type: none"> ● Release the protection. (→ 66) If the disc or the contents on the disc have been protected on another device, release the protection on the same device. ● It may not be possible to delete scenes that have been divided. Combine the divided scenes, and then delete them. (→ 58) ● It may not be possible to delete scenes that are displayed as [!/] on the thumbnail display. If the scenes are unnecessary, format the disc or SD card to erase the data. (→ 67) Please be aware that if a disc or SD card is formatted then all the data recorded on the disc or SD card will be erased. ● If the SD card's write protect switch is set to LOCK, then deletion and editing are disabled. (→ 22) ● Locked files cannot be deleted. Release the lock setting. (→ 62)
<p>The images on the SD card do not look normal.</p>	<ul style="list-style-type: none"> ● The data may be destroyed. It may have been destroyed by static or electromagnetic waves. Store important data on a PC or other products as well.
<p>Even if a disc or an SD card is formatted, it cannot be used.</p>	<ul style="list-style-type: none"> ● Either this unit or the disc or SD card may be damaged. Please consult a dealer. Use an SD card from 8 MB to 8 GB with this unit.

Problem

If the SD card is inserted in another device, it is not recognised.



The indication disappears.

The screen is frozen.

No operation can be performed.



“PUSH THE RESET SWITCH.” or “CHECK THE DISC AFTER PUSHING THE RESET SWITCH TO REPAIR IT.” is displayed.



When connected by the USB cable, this unit is not detected by the PC.



Check points

- Check that the device is compatible with the capacity or type of SD card (SD Memory Card/SDHC Memory Card) that you inserted. Refer to the operating instructions of the device for details.

- No operation can be performed on this unit when it is connected to a PC.
- Turn off the power to this unit. If the power cannot be turned off, press the RESET button, or remove the battery or AC adaptor and then reattach it. Turn on the power again. If normal operation is still not restored, detach the power connected, and consult the dealer who you purchased this unit from.

- After using the following method to restart the unit, eject the disc and clean it. (→ 20) If there are scratches on the disc, use a new disc.
- The unit has automatically detected an error. Press the RESET button with the projecting part of the grip belt **A**. This will restart the unit.

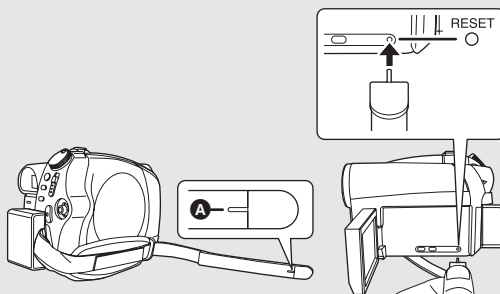

- If you do not press the RESET button, the power to this unit is turned off automatically about 1 minute later.
- Even after you press the RESET button, the indication may still appear repeatedly. If so, this unit needs repair. Detach the power connected, and consult the dealer who you purchased this unit from. Do not attempt to repair the appliance by yourself.

- Close the menu screen before connecting the USB cable.
- Select another USB terminal on the PC.
- Check the operating environment. (→ 75)
- Disconnect the USB cable, turn the unit off then on and then reconnect the USB cable.

Problem

When the USB cable is disconnected, an error message will appear on the PC.



Check points

- To disconnect the USB cable safely, double-click the  icon in the task tray and follow the instructions on the screen.

Cautions for use

In the event of abnormal operation (e.g. if the unit emits smoke or an unusual smell), immediately stop operating the unit and consult the Panasonic Customer Care Centre on 132600.

About this unit

- The unit, disc and SD card become warm after long operation, but this is not a malfunction.

Keep the DVD Video Camera as far away as possible from electromagnetic equipment (such as microwave ovens, TVs, video games etc.).

- If you use the DVD Video Camera on top of or near a TV, the pictures and sound on the DVD Video Camera may be disrupted by electromagnetic wave radiation.
- Do not use the DVD Video Camera near cell phones because doing so may result in noise adversely affecting the pictures and sound.
- Recorded data may be damaged, or pictures may be distorted, by strong magnetic fields created by speakers or large motors.
- Electromagnetic wave radiation generated by microprocessors may adversely affect the DVD Video Camera, disturbing the pictures and sound.
- If the DVD Video Camera is adversely affected by electromagnetic equipment and stops functioning properly, turn the DVD Video Camera off and remove the battery or disconnect AC adaptor. Then reinsert the battery or reconnect AC adaptor and turn the DVD Video Camera on.

Do not use the DVD Video Camera near radio transmitters or high-voltage lines.

- If you record near radio transmitters or high-voltage lines, the recorded pictures and sound may be adversely affected.

Make sure to use the supplied cords and cables. If you use optional accessories, use the cords and the cables supplied with them. Do not extend the cords and the cables.

Do not spray insecticides or volatile chemicals onto the unit.

- If the unit is sprayed with such chemicals, its body may be marred and the surface finish may peel off.
- Do not leave rubber or plastic products in contact with the unit for a long time.

When you use the unit in a sandy or dusty place such as a beach, do not let sand or fine dust get into the body and terminals of the unit.

Also, keep the unit away from sea water.

- Sand or dust may damage the unit. (Care should be taken when inserting and removing a disc or an SD card.)
- If sea water splashes onto the unit, wipe off the water with a well wrung cloth. Then wipe the unit again with a dry cloth.

When carrying the unit, do not drop or bump it.

- A strong impact can break the unit's casing, causing it to malfunction.

Do not use benzene, paint thinner or alcohol for cleaning the unit.

- Before cleaning, detach the battery or pull out the AC cable from the AC outlet.
- The camera body may be discoloured and the surface finish may peel off.
- Wipe the unit with a soft dry cloth to remove dust and fingerprints. To remove stubborn stains, thoroughly wring a cloth that has been soaked in a neutral detergent diluted with water and wipe the unit with it. Afterwards, wipe it with a dry cloth.
- When you use a chemical dust cloth, follow the instructions that came with the cloth.

Do not touch the laser pickup lens.

- If you touch the laser pickup lens directly it may cause malfunctions.

Do not use any other lens cleaners except a commercial available 8 cm DVD video camera lens cleaner.

- Using any other lens cleaners except the one for 8 cm DVD video camera could cause this unit to malfunction.

Do not use the unit for surveillance purposes or other business uses.

- If you use the unit for a long time, heat will build up inside it and this may cause a malfunction.
- This unit is not intended for industrial use.

When you are not going to use the unit for an extended time

- When storing the unit in a cupboard or cabinet, it is recommended that you place a desiccant (silica gel) in with it.

About the battery

The battery used in this unit is a rechargeable lithium-ion battery. It is susceptible to humidity and temperature and the effect increases the more the temperature rises or falls. In cold areas, the full charge indication may not appear or the low battery indication may appear about 5 minutes after starting use. At high temperatures, the protection function may be triggered, making it impossible to use the unit.

Be sure to detach the battery after use.

- If the battery is left attached, a minute amount of current continues to flow even if the unit's power is off. Keeping the unit in this state may result in over discharge of the battery. This may result in you not being able to use the battery even after it is charged.
- The battery should be stored in the vinyl bag so metal does not come into contact with the terminals.
- The battery should be stored in a cool place free from humidity, with as constant temperature as possible. (Recommended temperature: 15 °C to 25 °C, Recommended humidity: 40% to 60%)
- Extremely high temperatures or low temperatures will shorten the life of the battery.
- If the battery is kept in high-temperature, high-humidity, or oily-smoky places, the terminals may rust and cause malfunctions.
- To store the battery for a long period of time, we recommend you charge it once every year and store it again after you have completely used up the charged capacity.
- Dust and other matter attached to the battery terminals should be removed.

Prepare spare batteries when going out for recording.

- Prepare batteries for use up to 3 to 4 times the period you are planning to record for.
- Cold places such as a ski resort can shorten the period which you can record for.

If you drop the battery accidentally, check to see if the terminals are damaged.

- Attaching a battery with damaged terminals can damage the unit or AC adaptor.

Do not throw old battery into fire.

- Heating a battery or throwing it into a fire may result in an explosion.
- If the operating time is very short even after the battery has been recharged, the battery has worn out. Please purchase a new battery.

About the AC adaptor

- If the temperature of the battery is extremely high or extremely low, charging may take time or the battery may not be charged.
- If the CHARGE lamp keeps flashing, make sure that the terminals of the battery or the AC adaptor are not exposed to dirt, foreign objects or dust, then reconnect them properly. If the charging lamp is still flashing, something may be wrong with the battery or AC adaptor. Contact your dealer.
- If you use the AC adaptor near a radio, radio reception may be disturbed. Keep the AC adaptor 1 m or more away from the radio.
- When using the AC adaptor, it may generate whirring sounds. However, this is normal.
- After use, be sure to disconnect the AC adaptor. (If it is left connected, a minute amount of current is consumed.)
- Always keep the electrodes of the AC adaptor and battery clean.

LCD monitor/viewfinder

- When the LCD monitor gets dirty, wipe it with a dry soft cloth.
- In a place with drastic temperature changes, condensation may form on the LCD monitor. Wipe it with a soft dry cloth.
- When the unit has become very cold, for example due to storage in a cold area, its LCD monitor will be slightly darker than usual immediately after the power is turned on. The

normal brightness will be restored when the unit's internal temperature rises.

Extremely high precision technology is employed to produce the LCD Monitor screen featuring a total of approximately 123,000 pixels. The result is more than 99.99% effective pixels with a mere 0.01% of the pixels inactive or always lit. However, this is not a malfunction and does not affect the recorded picture.

Extremely high precision technology is employed to produce the viewfinder screen featuring a total of approximately 113,000 pixels. The result is more than 99.99% effective pixels with a mere 0.01% of the pixels inactive or always lit. However, this is not a malfunction and does not affect the recorded picture.

About condensation

When condensation forms on the unit, the lens will cloud up and the unit may not work properly. Make every effort to ensure that condensation does not form. If it does form, take the actions described below.

Causes of condensation

Condensation takes place when the ambient temperature or humidity is changed as follows.

- When this unit is brought inside from the cold (e.g. a ski slope) to a warm room.
- When this unit is moved from an air-conditioned car to outside.
- When a cold room has been warmed up quickly.
- When cool wind from an air conditioner is directly blown onto this unit.
- After summer afternoon showers of rain.
- When this unit is in a very humid place where the air is thick with steam. (e.g. a heated swimming pool)

Helpful hint

If, for example, you have used this unit for recording on a ski slope and are taking it into a heated room, place the unit inside a plastic bag,

remove as much of the air from inside the bag as possible, then seal the bag. Leave the unit for about an hour in the room so the temperature of the unit is close to the ambient temperature of the room, then use it.

Licenses

- SDHC Logo is a trademark.
- U.S. Patent Nos. 6,836,549; 6,381,747; 7,050,698; 6,516,132; and 5,583,936.
This product incorporates copyright protection technology that is protected by U.S. patents and other intellectual property rights. Use of this copyright protection technology must be authorized by Macrovision, and is intended for home and other limited viewing uses only unless otherwise authorized by Macrovision. Reverse engineering or disassembly is prohibited.
- Manufactured under license from Dolby Laboratories.
Dolby and the double-D symbol are trademarks of Dolby Laboratories.
- Microsoft®, Windows®, Windows Vista®, DirectDraw®, DirectSound®, DirectX®, and Internet Explorer® are either registered trademarks or trademarks of the Microsoft Corporation in the United States and/or other countries.
- Microsoft product screen shot(s) reprinted with permission from Microsoft Corporation.
- IBM, PC/AT and PowerPC are registered trademarks of International Business Machines Corporation of the U.S.
- Intel®, Core™ and Pentium® are the registered trademarks or trademarks of the Intel Corporation in the United States and other countries.
- Macintosh and Mac OS are either registered trademarks or trademarks of Apple Inc. in the United States and/or other countries.
- Other names of systems and products mentioned in these instructions are usually the registered trademarks or trademarks of the manufacturers who developed the system or product concerned.

Explanation of terms

Automatic white balance

White balance adjustment recognises the colour of light and adjusts so the white colour will become a purer white. The unit determines the hue of light that comes through the lens and white balance sensor, thereby judging the recording condition, and selects the closest hue setting.

This is called automatic white balance adjustment.

However, since the unit only stores white colour information under certain light sources, automatic white balance adjustment does not function normally under other light sources.

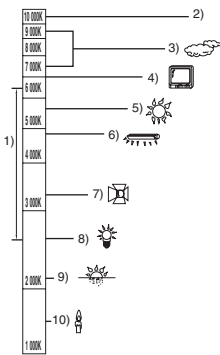

The illustration above shows the range over which the auto white balance functions.

- 1) The effective range of automatic white balance adjustment on this unit
- 2) Blue sky
- 3) Cloudy sky (rain)
- 4) TV screen
- 5) Sunlight
- 6) White fluorescent lamp
- 7) Halogen light bulb
- 8) Incandescent light bulb
- 9) Sunrise or sunset
- 10) Candlelight

Outside of the effective range of automatic white balance adjustment, the image will become reddish or bluish. Even within the effective range of automatic white balance adjustment, the automatic white balance adjustment may not function properly if there is more than one light source. For light outside the functional automatic

white balance adjustment range, use the manual white balance adjustment mode.

White balance adjustment

White balance adjustment determines the white colour under different light sources. By recognising which is the white colour under sunlight and which is the white colour under a fluorescent light, the unit can adjust the balance among the other colours.

Since the white colour is the reference for all the colours, the unit can record pictures in a natural hue if it can recognise the reference colour white.

Auto focus

The lens is moved forward or backward automatically to bring the subject into focus.

Auto focus has the following characteristics.

- Adjusts so that the vertical lines of a subject are seen more clearly.
- Attempts to bring an object with higher contrast into focus.
- Focuses on the screen centre only.

Due to these characteristics, auto focus does not work correctly in the following situations. Record pictures in the manual focus mode.

Recording distant and close-up objects at the same time

Since the unit focuses on whatever is at the centre of the screen, it is difficult to bring the background into focus when close-up objects are placed in focus. When recording people with distant mountains in the background, you cannot focus on both the subject which is close-up and the objects which are in the distance.

Recording a subject behind a dirty or dusty window

The subject behind the window will not be focused because the focus is on the dirty window.

Similarly, when recording something on the opposite side of a road with heavy traffic, a vehicle that happens to pass by may be brought into focus.

Recording a subject that is surrounded by objects with glossy surfaces or by highly reflective objects

Since whatever is shiny or glistens is brought into focus, it is hard to focus on the subject to be recorded. The focus may become blurry when recording subjects at the beach, at night or in scenes involving fireworks or special lights.

Recording a subject in dark surroundings

The unit cannot focus correctly because the light information that comes through the lens decreases considerably.

Recording a fast-moving subject

As the focus lens-inside moves mechanically, it cannot keep up with a fast-moving subject. When, for example, recording a sports event with fast moving subjects, the focus may lose its sharpness.

Recording a subject with little contrast

It is easy to bring subjects with a sharp contrast or vertical lines or stripes into focus. This means that a subject with little contrast, such as a white wall, may become blurry because the unit achieves focus based upon the vertical lines of an image.

Specifications

DVD Video Camera

Information for your safety

Power source:	DC 9.3 V/7.2 V
Power consumption:	Recording 5.9 W

Signal system	CCIR: 625 lines, 50 fields PAL colour signal
Recording format	DVD Video Recording format (DVD-RAM, DVD-RW) DVD-Video format (DVD-RW, DVD-R, DVD-R DL)
Image sensor	1/6" CCD image sensor Total: 800 K Effective pixels: Moving picture: 400 K (4:3), 370 K (16:9) Still picture: 410 K (4:3), 380 K (16:9)
Lens	Auto Iris, F1.9 to F4.3 Focal length: 1.8 mm to 75.6 mm Macro (Full range AF)
Zoom	42× optical zoom, 70/2000× digital zoom
Monitor	2.7" wide LCD monitor (approx. 123 K pixels)
Viewfinder	Colour electric viewfinder (approx. 113 K pixels)
Microphone	Stereo (with a zoom function)
Speaker	1 round speaker Ø 20 mm
Standard illumination	1,400 lx
Minimum required illumination	6 lx (approx. 2 lx with the Colour night view function)
Video output level	1.0 Vp-p, 75 Ω
Audio output level (Line)	316 mV, 600 Ω
USB	Card reader/writer function (No copyright protection support) Hi-Speed USB (USB 2.0) compliant PictBridge-compliant
Dimensions (excluding the projecting parts)	52.8 mm (W) × 89.5 mm (H) × 128.6 mm (D)
Mass (without battery and a disc)	Approx. 400 g
Operating temperature	0 °C to 40 °C (0 °C to 30 °C when connected to the PC)
Operating humidity	10% to 80%

Motion pictures

Recording media	8 cm DVD-RAM Ver. 2.1 8 cm DVD-RW Ver. 1.1/2X-SPEED (2X/1X) 8 cm DVD-R for General Ver. 2.0 8 cm DVD-R for DL Ver. 3.0
Compression	MPEG2
Recording mode and transfer rate	XP: 10 Mbps (VBR) (Approx. 18 min recordable time on a single-sided DVD-RAM) SP: 5 Mbps (VBR) (Approx. 37 min recordable time on a single-sided DVD-RAM) LP: 2.5 Mbps (VBR) (Approx. 75 min recordable time on a single-sided DVD-RAM)
Audio compression	Dolby Digital, 16 bit (48 kHz/2 ch)

Still pictures

Recording media	SD Memory Card: 8 MB/16 MB/32 MB/64 MB/128 MB/256 MB/512 MB/1 GB/2 GB (FAT12 and FAT16 format corresponding) SDHC Memory Card: 4 GB/8 GB (FAT32 format corresponding)
Compression	JPEG (Design rule for Camera File system, based on Exif 2.2 standard), DPOF corresponding
Picture size	640×480 (4:3), 640×360 (16:9)

AC adaptor





Information for your safety



Power source:	AC 110 V to 240 V, 50/60 Hz
Power consumption:	19 W
DC output:	DC 9.3 V, 1.2 A (Unit operation) DC 8.4 V, 0.65 A (Battery charging)

Dimensions	92 mm (W) × 33 mm (H) × 61 mm (D)
Mass	Approx. 115 g

Specifications may change without prior notice.

Number of recordable pictures on an SD card

Picture size	0.3M (640×480)		0.2M (640×360)	
				
8 MB	42	86	42	86
16 MB	97	195	97	195
32 MB	210	420	210	420
64 MB	430	870	430	870
128 MB	820	1650	820	1650
256 MB	1710	3430	1710	3430
512 MB	3400	6790	3400	6790
1 GB	6800	13600	6800	13600
2 GB	13830	27660	13830	27660
4 GB	27150	54310	27150	54310
8 GB	55260	99999	55260	99999

- The number of recordable pictures depends on whether [] and [] are used together and on the subject being recorded.
- The numbers shown in the table are approximations.
- The memory capacity indicated on the label of an SD card is the total of the capacity for copyright protection and management and the capacity which can be used on the unit, a PC etc.

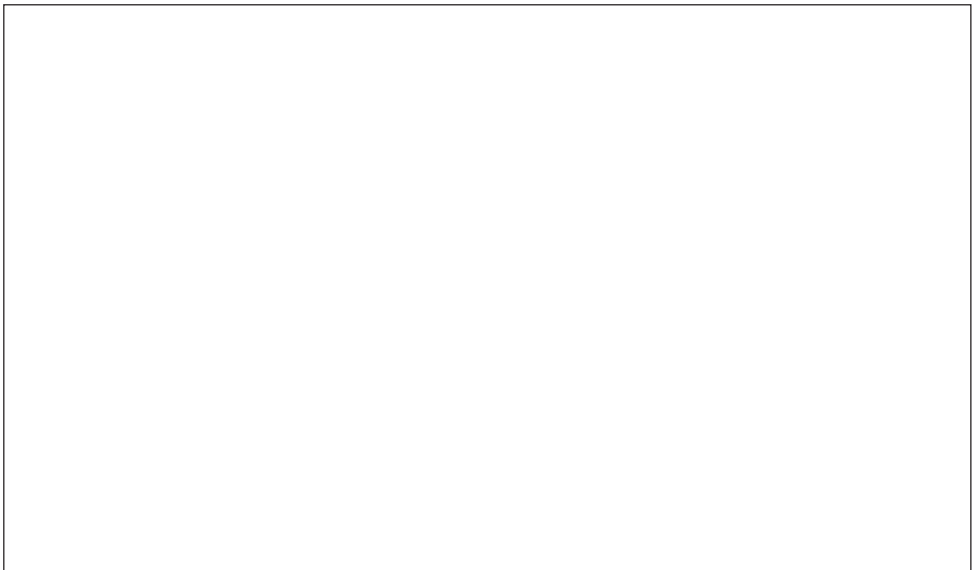





LSQT1335 B
F1107GY1038



Matsushita Electric Industrial Co., Ltd.
Web site: <http://panasonic.net>