



# DYCOTE\*

Manual

VESUVIUS



## Introduction

Although various aspects of the permanent mould casting process have been studied and developed, such as alloy selection, machine automation, etc., little attention has been given to the products and methods for preparing the surfaces of the die.

It is often the operator that selects and prepares the coating material, and the final choice is based almost exclusively on practical experience rather than technical and theoretical considerations. This manual aims to provide foundry engineers and operators involved in die preparation with the information required for the correct use of coating materials, in order to optimise efficiency and so improve foundry production.

This latest revised and illustrated edition of the Foseco DYCOTE Manual comprises: An analysis of the functions of coating materials, preparation and application methods, and examples of die preparation for the most common castings.

The tables with the characteristics of DYCOTE products have been extended, rationalised and now include a new family of DYCOTE's, the DURA group. This offers extended coating life, to improve productivity.

Where a special coating is only available in some countries it has not been included in the table. Also not every mentioned coating is available in every country. For more details, please contact your local Foseco company.

The manual is completed with appendices on cryogenic sandblasting, coating application defects and defects in die-cast parts.

## Die casting and the role of coatings

Die casting is a process that uses permanent moulds made of metal (dies) enabling large batches of identical castings to be produced. Contrary to sand moulds, in which the permeability of the compacted sand allows the air to escape freely during casting, metal moulds are impermeable and therefore must be designed with suitable air vents. The advantages of the die process over sand are:

- + superior structural characteristics
- + better appearance of the casting
- + greater dimensional accuracy
- + reduced feed demand
- + higher production rates
- + lower cost (for larger batches)



Compared to sand moulds, the use of a permanent metal mould requires completely different conditions for filling the metal alloy and for its solidification; the function of the die coating – a semi-permanent layer deposited on the walls – is to control these processes and to facilitate release of the casting, prolong die life, etc. In die casting, coating selection and its method of application are at least as important as other factors, such as the design of the die, type of alloy, temperature of the metal and so on. Foseco produces a vast range of die coating products under its DYCOTE brand as well as other products and systems which have long been used in all areas of the modern metal foundry. In addition, Foseco is constantly seeking new products and systems to make casting production safer, more environmentally friendly and more economic.

### Function of DYCOTE

The principal functions required of a coating for die casting are:

- + Control of the metal flow to ensure that it reaches all parts of the die at a sufficient temperature to prevent the formation of seams, cold laps, etc.
- + Control of heat transfer to obtain better solidification and ensure that the castings are properly fed.
- + Easy release: since castings are extracted at just below the solidification temperature, easy release ensures that castings do not come out deformed.
- + Good surfaces, and therefore a reduction in finishing costs.
- + Longer die life, therefore increased productivity and reduced maintenance. These results are directly in line with the characteristics of DYCOTE.

### Heat transfer control

The control of heat dispersal through the various sections of the die is undoubtedly the most important characteristic of DYCOTE, because it permits control of both directional solidification and die filling (which will be discussed in the section „Metal flow control“).

The degree of insulation depends on:

- + the properties of the raw material used
- + the method used to apply DYCOTE to the surface of the die
- + the thickness of the layer.

The basic ingredients of DYCOTE are:

**Fillers:** composed generally of refractory powders such as  $\text{TiO}_2$ , talc, mica, silica flour, iron oxide,  $\text{Al}_2\text{O}_3$ , etc. At the normal casting temperature of aluminium alloys in the die-casting process (650-800 °C), the refractoriness of the fillers is such as to ensure that no chemical reaction takes place. Their function therefore remains exclusively physical, i.e. only thermal conductivity and particle form and dimensions are involved (the importance of the latter factors will be discussed when dealing with metal flow control).

**Bonding agents:** in the majority of cases sodium silicate with an appropriate  $\text{SiO}_2/\text{Na}_2\text{O}$  ratio, although sometimes other materials are used, such as certain types of clays, starch, etc. The DYCOTE DURA family is based on a new binder system, which offers improved bond toughness

**Water:** with controlled hardness.

The degree of compaction of the layer, which depends on the application method, affects the property of thermal insulation: if the layer is not very compact, contact between particles is slight, and therefore the permeability and insulation properties are greater. DYCOTE products are usually supplied in the form of a paste for dilution with water depending on the type of application (and therefore the degree of insulation) desired, i.e. with brush or spray application; the dilution ratio is relatively unimportant from this point of view, since excess water is removed by heat from the warm die surface (120-140 °C with brush application and around 180-250 °C for spray application).

Brush application leaves the die with a very rough surface full of air pockets. This gives a high degree of insulation, ideal for the surfaces not requiring special finishes (such as runners and risers).

In spray application, DYCOTE products are applied in several thin layers until the desired thickness is obtained. In this case the layer also comprises air pockets but they are smaller than in the previous case, and are due to the accumulation of particles rather than the formation of bubbles in the bonding agent.

Air pressure and distance of the pistol from the surface of the die must be sufficient to overcome the phenomenon of evaporation and permit the DYCOTE to adhere completely to the die surface. Air pressure of 0,4-0,5 MPa and a distance of 25-30 cm from the die is recommended (see figure 6).

Good quality castings with no, or at least only a controlled level of, solidification shrinkage are obtained if the concept of directional solidification is observed, i.e. if solidification proceeds steadily towards the risers from the parts of the casting farthest from them.

An appropriate coating, with the thickness varying with those of the casting, allows the control of heat transfer, favouring directional solidification. For example, by applying on a

thin section of the casting a thick layer of a coarse insulating DYCOTE, the solidification rate will be reduced. On a thick section of the casting, a thin layer of a fine DYCOTE can be applied, thereby accelerating solidification, the cooling characteristics of the metal can be rendered sufficiently uniform to give a sound casting. The larger the difference between the sections of a casting, the greater should be the insulating properties of the DYCOTE applied. In extreme cases, the desired effect can be obtained by removing or rubbing down the coating from thick sections. Runners and risers, where metal has to remain molten for a certain time to feed the casting during solidification, normally require a thick layer of an highly insulating DYCOTE.

### Controlling metal flow

Since the coating is thin (50-150 microns) and the temperature differential between the molten alloy and the die varies between 400 and 500 °C, the thermal conductivity stays relatively high and the transmission of heat from the metal to the die is instantaneous and intense. The physical characteristics of DYCOTE (coarseness, filler size), have a marked effect not only on the surface quality of the casting, but also on the flow of metal and degree of insulation. For example, a thin layer with ample contact with the metal increases the

transmission of heat and rapidly reduces fluidity; this can result in incomplete filling, cold laps, etc., especially when the metallostatic pressure is low, as for example in the case of castings with thin sections.

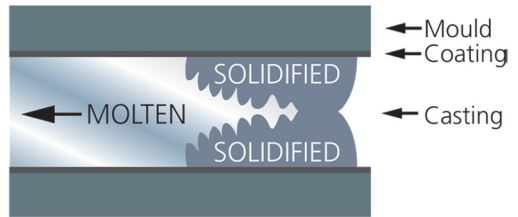

Figure 1: Directional Solidification

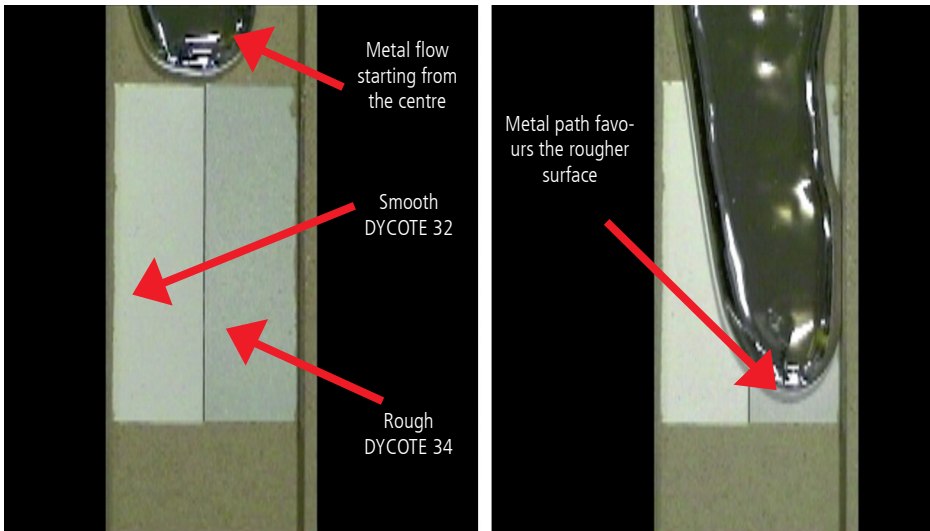

Figure 2

Source: Daniel Whitrow, University Birmingham

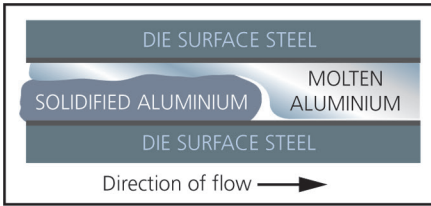

Figure 3: Formation of Cold Lap

Conversely, with a layer of DYCOTE with a coarse surface, the contact between molten metal and DYCOTE is significantly reduced, because the metal, due to its surface tension, is first in contact with only the „peaks“ of the layer, and only after a time, though this is extremely short, does it penetrate into the „valleys“, after which the air escapes through the channels in the permeable coating. The result of this phenomenon is to reduce heat loss to a minimum in the molten metal, which thus maintains its fluidity at the critical moment to fill the die completely.



The roughness of the refractory particles also influences the flow of metal. Given that the surface tension of aluminium is high, its flow characteristics and wettability are low; as a consequence of this, if a refractory filler with sharp edges is used, the aluminium oxide skin will be continuously broken down during pouring, and the metal will run much more easily over the surfaces. Unfortunately coarse coating layers with sharp-edged particles tend to become smoother with each casting. Indeed, the sharp projections of the layer bind to the surface of the casting during solidification and break off during extraction: it may therefore be necessary to touch up regularly to obtain better results consistently.

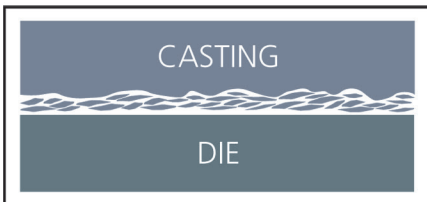

Figure 4: Fine coating

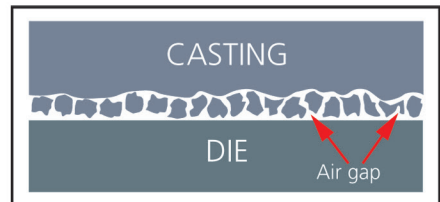

Figure 5: Coarse coating

### Easy release

Regardless of the design of the die, release can be made easier by using graphite in a colloidal and semi-colloidal form. Graphite can be used as a component of the refractory base of the DYCOTE, in the coating itself, or applied separately on top of a standard DYCOTE. When graphite is used in the composition of refractory DYCOTE, care must be taken to avoid weakening the coating due to the thin layers of graphite flaking off. If a DYCOTE flakes it will tend to lose its thermal insulation. Graphite for application over a layer of DYCOTE base is often used on areas of a die where release is difficult, or on its moving parts. The composition of the DYCOTE must be accurately controlled since, if the bonding agent forms a hard „shell“ around each graphite particle, its lubricating properties will be reduced or even completely destroyed. When a graphite-based DYCOTE is applied the lamellae are spread in a disorderly manner, and therefore numerous tiny blisters may form in the lining, with the effect of reducing the thermal conductivity of the layer. After a few castings, however, there is a tendency for the graphite film to become flat and impermeable (this can be seen from the shiny appearance of the film after release) as a result of continual friction against the metal caused by shrinkage during solidification.

Therefore the bonding agent must be weak, allowing part of the overlaid film to break off, exposing the underlying layer over which the application of graphite is repeated. The drawback here, which arises from having to apply a second coating, is that this tends to cancel out the advantages of particle size in base coats. What happens is that the graphite tends to collect in the „valleys“, so that the layer takes on a smoother appearance, reducing the fluidity of the metal.

Recently, insulating coatings have been introduced with a composition that includes Boron Nitride (BN), which has a hexagonal graphite-like structure. The presence of Boron Nitride reduces the wettability to molten aluminium while increasing the refractories of the coating. Boron Nitride allows excellent release while the white colour prevents the discolouration of the casting, which is often seen with graphite.



## Good surface

As seen from the information above, a good surface will be linked to the choice of DYCOTE; for example flat thin surfaces require a coarse angular layer which favours the flow of metal. This is because the metallostatic pressure is low and filling the die is facilitated by the continual breakdown of the aluminium oxide film. The surface of the casting will be relatively rough but sound, while a smooth layer would cause filling to be incomplete. The parts of the mould corresponding to thick sections of the casting can be coated with finer DYCOTE products, since the metallostatic pressure in these areas is higher. Also the type of application will affect the final result: brush application produces an uneven surface, while spray application produces a smooth even surface.

## Lifetime

The factors that contribute to the life of a coating layer are:

- + Type of bonding agent
- + Method of application
- + Type of refractory

The bonding agent must not only resist high temperatures but also the high temperature changes that cause tensile stresses in the coating layer. Very often sodium silicate is used with a well determined  $\text{Na}_2\text{O}/\text{SiO}_2$  ratio, as it not only resists thermal cracking, but over time becomes more resistant to high temperatures and therefore is long-lasting. As stated initially, the application method is important and the die temperature is the most critical factor.

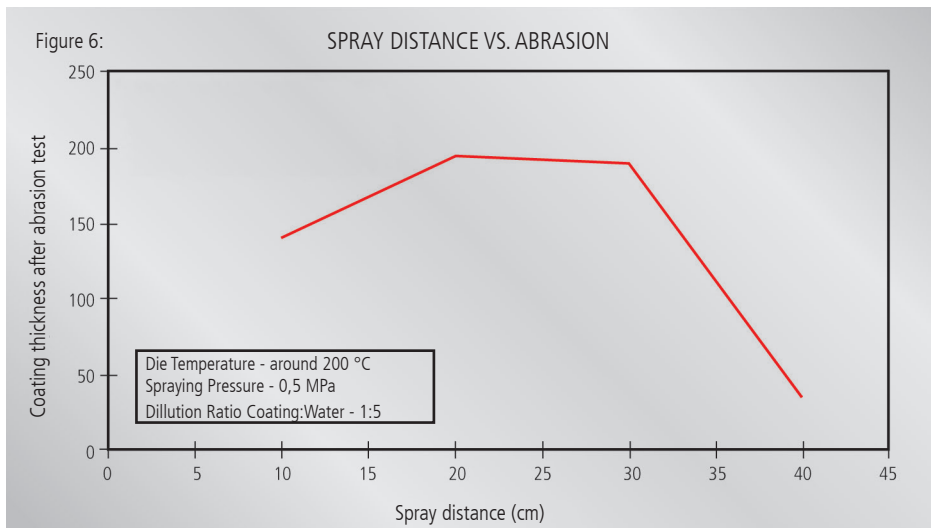

If the temperature is too low and consequently water evaporation is retarded, the coating forms an impermeable film that detaches from the die forming blisters, due to steam forming under the layer. Then the layer can contract and detach when it is completely dry, leaving part of the die exposed. If the temperature is too high and water evaporation too violent, the refractory particles, surrounded by a film of water and sodium silicate, will become separated from each other and also from the surface of the die by tiny explosions which take place when the steam is released into the air. The result is a weak, coarse, powdery layer that peels off easily. Although, as has been said, the ratios of the constituents remain constant despite being diluted with water, the ratio of dilution influences the final appearance of the coating. As a general rule, insufficient dilution results in a weaker bond between the coating and the die, but the layer will be rough will have lower thermal conductivity and therefore will have better insulating properties.

### **Magnesium alloys**

DYCOTE also adapts to magnesium alloys, where prior to casting, the procedure for preventing the oxidation of the metal is carried out by saturating the die cavity with inert gas. The DYCOTE BN coatings are compatible with Magnesium alloys.

### **Copper alloys**

The major difficulty encountered when die casting in these materials is the deposit of zinc oxide on the die surface. If it is not removed, it rapidly forms a thickness that renders the surface of the castings unacceptable. The dies are therefore designed so they can be dismantled and immersed in a bath containing a suspension of a carbonaceous material that inhibits the formation of zinc oxide as well as coating the die this practice also cools the die. The carbonaceous material is deposited on the surface in a porous structure, giving it both insulating and lubricating properties. The inhibitor to a certain extent prevents the formation of zinc oxide on the surface. Another advantage of this process is the high production derived from the simplicity of the immersion application method.

### **Aluminium bronze**

In this case DYCOTE products can be used for light alloys, together with a second graphite-based coat to facilitate release. Use can also be made of the immersion method described above.

### Low pressure casting

In this process the metal is injected into a mould mounted on a sealed furnace. The air or nitrogen pressure applied to the surface of the metal causes it to rise and pass into the mould through a tube. The pressure required to move the metal is slightly higher than the metallostatic pressure. Normally the same DYCOTE products are used as for gravity casting.

### Preparing the Die Cleaning

A fundamental requirement is cleaning the surface to be coated: no residue of previous coatings must remain and also no oil, grease or soot. Cleaning can be performed with wire brushes or by blasting with sand, alumina steel shot etc. Recently, dry ice cleaning systems have been developed that allow blasting in

situ without having to dismantle the die, with clear advantages from the environmental point of view but with problems getting into deep parts of the die. Also a big problem is the loud noise. The disadvantage is, that not all coating types can be removed.

### Die temperature

Dies generally operate at a temperature of around 300 to 400 °C, but the coating must be first applied in a variable range between 180 and 250 °C, depending on the type of DYCOTE and the degree of adherence desired. During operation local areas may require repair, this operation must be done at the running temperature and needs a special procedure, which is described in Figure 7.

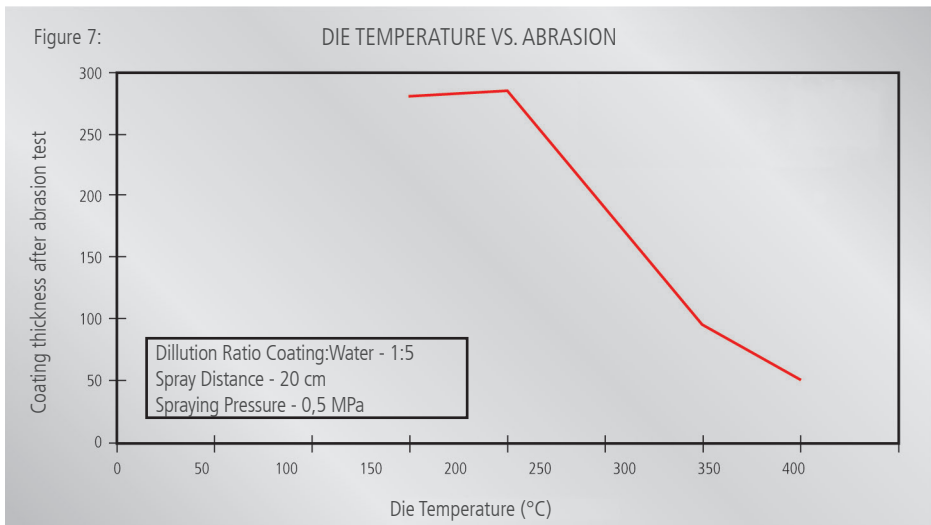

As the application temperature increases, the adherence is reduced. Therefore the temperature of the die should be controlled accurately during application, using a contact thermocouple. The temperature to which the die is heated before coating should preferably be higher (250-300 °C), after which it is left to cool, preferably under a cover, to the correct coating temperature: this improves the uniformity of the die temperature and avoids intermediate heating when successive layers must be applied. After the die has been coated and before the first casting is poured, it must be heated to working temperature. To get the best results when retouching the coating, it would be preferable first to bring the die temperature down to the recommended coating temperature.

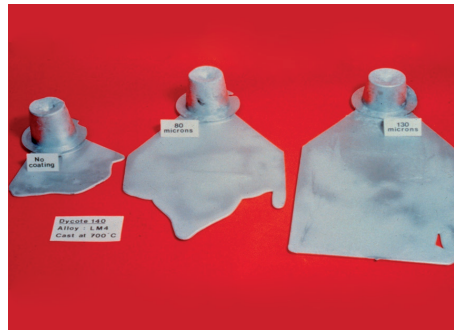
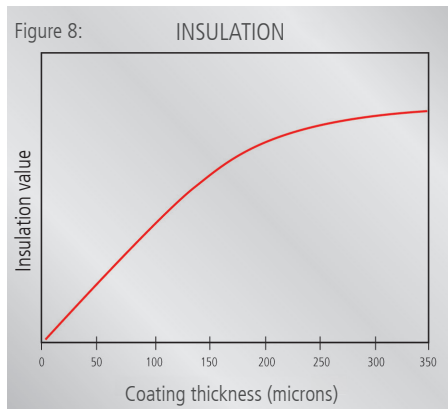

Figure 9: Effect of coating thickness on insulation and fluidity

### Coating thickness

The coating thickness must be defined and controlled on the basis of the insulation required. Thicknesses in the order of 50  $\mu\text{m}$  and 150  $\mu\text{m}$  (see figure 8) are sufficient to get the maximum degree of insulation typical for the product used.

For castings and risers, brush application can achieve a thickness of up to 4-5 mm. The coating thickness is the principal factor in the heat exchange between casting and die. Coatings applied carelessly over previous coatings result in thick layers with a number of negative consequences, such as alteration of the thickness, poor layer tightness and hot spot defects on the casting. The effect of coating thickness on filling ability is illustrated in figure 9 which shows the effect on fluidity.

## Coating life

This is certainly the aspect of greatest interest and it is linked to the quality of the careful preparation of the die and the die coatings. Absolute thorough cleaning and correct heating are needed to ensure that all types of DYCOTE adhere properly to the die metal. A carefully applied coating could last at least one day, potentially one week depending on the casting design.

Those able to achieve these results will see the benefits especially since the long life of the coating is essential for dies to operate consistently. Recently new compositions of DYCOTE have been formulated. A range of fine, medium and coarse DYCOTE coatings with extended life have been developed. In most cases further improvements in coating life can also be achieved by curing DYCOTE coatings at 350 to 400 °C for over one hour immediately after coating.

## Preparing the Materials

Adequate storage and appropriate preparation of the coating materials are of vital importance for obtaining optimum performance from the products used.

DYCOTE must be stored and applied in an enclosed, cool, dry place not exposed to direct sunlight.

DYCOTE coatings are sensitive to frost.

DYCOTE must be stored at ambient temperature (10-25 °C).

Storage at a stable temperature will keep the viscosity and density of the product constant. Too high a temperature leads to changes in viscosity and accelerated biodegradation. Too low a temperature will alter the viscosity and may prevent the use of DYCOTE products which, being generally water-based, will freeze if the temperature falls below 0 °C, causing it to lose its binding property.



Figure 10 and 11: Example of DYCOTE preparation room, separated from production

Stocks are used on the basis of their „age“ (priority is given to materials stored for the longest period), so that the DYCOTE will be as fresh as possible. The quantity of stored product must be such as to enable it to be used according to the date on the label. In particular, purchasing the necessary material one month in advance will provide an adequate level of stock.

### Preparing the Mixtures

Proper mixing and preparation of DYCOTE is essential for obtaining the correct density, and also for obtaining optimum characteristics of use and reproducibility. Careful and controlled preparation of the DYCOTE is an essential part of the process and to ensure this the DYCOTE should be mixed and stored in a separate, clean and controlled room remote from the production area. Using an appropriate mixer is the best way to prepare DYCOTE.

Foseco has developed a system called “Carry & Mix” which helps to dilute and store the premixed coating. Carry & Mix is available in a fixed and trolley mounted version.

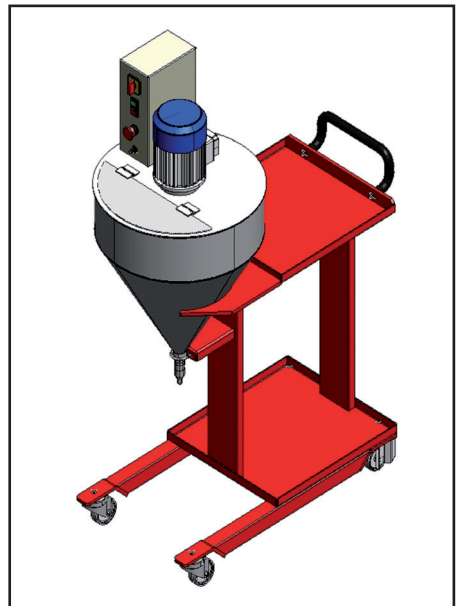

Figure 12: Carry & Mix

The mixing procedure is as follows:

- + Add approximately 1/3 to 1/2 of the total water to the container
- + Start the mixer
- + Gradually add the correct quantity of paste to form a thick mixture without lumps
- + Gradually add water until the mixture is slightly thicker than the density of use
- + Once the mixture has a uniform appearance, increase the quantity of water to the required density for the application.

The mixed product must be kept covered. Covering it reduces water evaporation and reduces the risk of contaminants entering the container. The container must be cleaned regularly at least once a month. This is required with water-based products to prevent the formation of biological encrustation.

## Checking and Control

DYCOTE products are subjected to strict quality controls to ensure that they reach the customer in optimum condition, however further controls are required when the product is used. Many of these controls fit easily into the control programs of the foundry.



Figure 13: Density measured by weight and volume



Figure 14: Baumé densimeter

Other checks:

- + The appearance of DYCOTE, as is or mixed, should always be similar.
- + The presence of lumps or foreign matter can be identified by examining the product.
- + Checking the label / production date.

Test	Method	Note
Density	Baumé	Density measurement using a gauge rod with a bulb of calibrated weight at one end, which is inserted into the mixture; the denser the mixture, the less the rod sinks.
	Weight/Vol.	Measurement of the weight of a known volume of material.
Solid Contents	Dry residue	A weighed quantity of the mixture is dried in an oven and weighed again. The dry residue is the % ratio between the final weight and initial weight.



## Application Method

The coating can be applied using several methods:

- + Brush
- + Spray
- + Immersion

For dies the quickest and most suitable method is spray application. Brush application is reserved for plain areas (runners and risers) where the lining must be much thicker, or for small details that must be coated in a different way from the rest of the die. Immersion application is mainly used for copper alloys, where the coating also has to cool the die.

## Spray application

Essentially there are two different types of spray devices:

- + Siphon pistol (air at high pressure), which uses compressed air to create a partial vacuum that forces the fluid through the pistol, transforming the coating into tiny droplets.
- + Air-less systems, pumping the mixture at high pressure into the pistol where it is forced through a narrow portion and then atomised by expansion.

Figure 15:

DILUTION RATIO VS. ABRASION THICKNESS

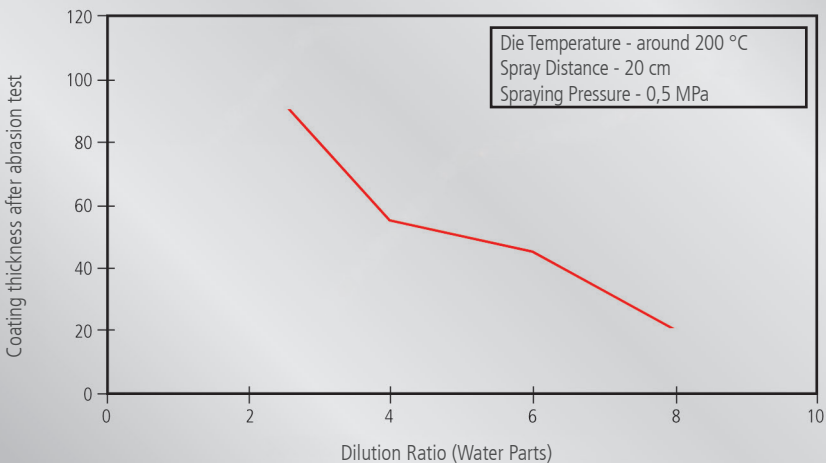

The operations that must be performed to obtain a correct coating are:

- + The pistol must be completely clean throughout, particularly the nozzle.
- + Fill the tank only with the quantity of mixture necessary. Discard the excess quantity or put it back in the mixer for application.
- + Use the product in the pistol without lengthy stops (>10 minutes).
- + Set the line pressure to 0,4-0,5 MPa (depending on the dilution of the mixture). Too much or too little pressure causes the formation of drops instead of a mist.
- + Start the coating runs from outside the die and avoid spraying intermittently. Make short passes and keep the pistol moving all the time.
- + Maintain a distance of 20-30 cm between pistol and die.
- + Work quickly but carefully. Each pass cools the die a little.
- + If the distance of application is too close, the coating tends to become thicker, slow to dry and can cause stains on the casting; the layer tends to become too thick.



Figure 16: DYCOTE spraygun

- + If the distance of application is too great, part of the water medium evaporates before contact with the die (dry spray), producing coarse surfaces on the resulting casting and poor coating adhesion.
- + It is preferable to apply the coating in several thin layers rather than in one or two thick layers.
- + Between one layer and the next, the coating must be allowed to dry.
- + Depending on the type of casting a typical coating thickness for insulation should be 150 to 250  $\mu\text{m}$ , whilst for smooth surface finish a coating thickness of 30 to 50  $\mu\text{m}$  is applied.

- + For optimum performance the thickness of the coating should be measured at various stages of application.
- + The operator should move around the die to coat from several directions and so reach the surfaces to be coated from different angles, thus avoiding the „shadow“ effect. This practice also avoids accumulating too much coating material on the operator’s side and getting „dry spray“ on the opposite side.
- + Do not allow the coating to run on the die.
- + Always clean the equipment after use.

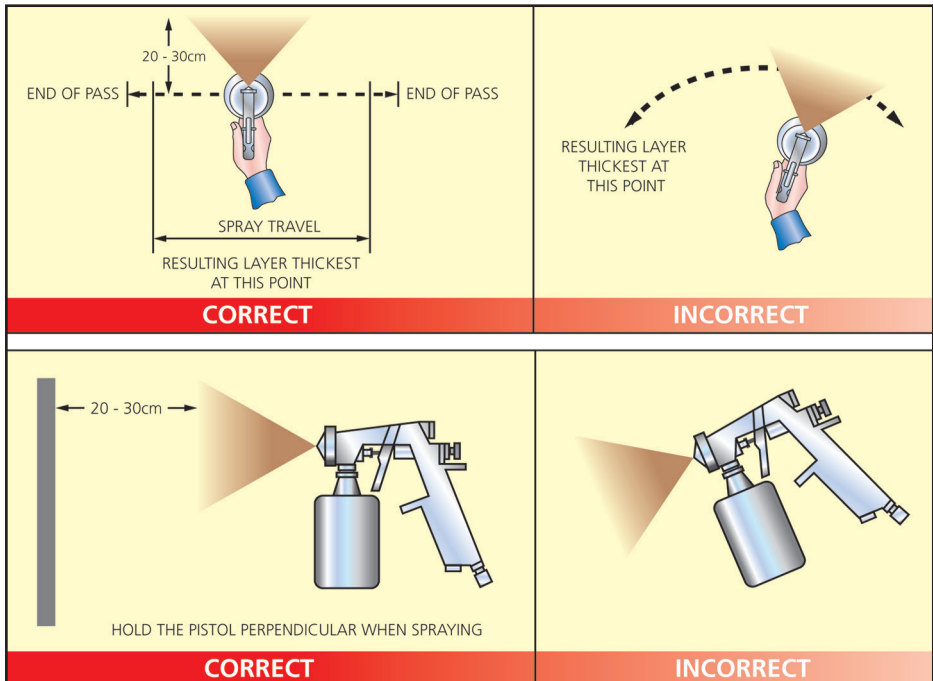

### Controlling the Thickness of the Coating

The thickness of the coating is a difficult parameter to control, because of the difficulty of working on very hot surfaces, therefore operators have always been left to work it out from experience, the result being inconsistency from one die to the next and between surfaces of the same die. Thickness gauges are currently available which can be used on hot dies, at all points.

This allows the caster to relate the coating thickness to the metallurgical structure of the casting and, by adopting the correct spraying system, to correct the thickness, adapt it to requirements and avoid scrap. Controlling the coating thickness also permits better control of directional solidification, important for ensuring sound castings.



Figure 17: Magnetic system „Pull off Gauge 157“  
Elcometer Instruments Ltd. Manchester



Figure 18: Ultrasonic system Sonacoat F



Figure 19: Infrared thermometer

### Controlling Die Temperature

Die temperature is a parameter that must be controlled, in order to get the best bond between the coating and the die. Although an experienced operator may be able to judge to temperature, best results are obtained by using a suitable thermocouple. Contact thermocouples and infrared or laser thermometers are now available for controlling die temperature. This enables the caster to apply the coating at the correct temperatures.



Figure 20: Contact thermocouple

## Foseco DYCOTE Coatings

Type of coating	Grain size	Thinning ratio	Application, Description
Base coating			
DYCOTE DR87	25µm	1:1 - 1:3	Base coating for all applications, apply at 180°C
Insulating Coatings			
DYCOTE D 39 and DYCOTE D 39 ESS	15µm	1:3 - 1:5	Wheel castings. ESS version with extra binder.
DYCOTE D BN 120	35µm	1:10 - 1:20	Contains Boron Nitride for smooth surface finish with long life.
DYCOTE D BN 130	50µm	1:10 - 1:20	Good surface finish with long life. Contains Boron Nitride.
DYCOTE D 7039	78µm	1:3 - 1:5	Wheel casting for top die and top core;rib cylinder.
DYCOTE D BN7039	78µm	1:3 - 1:5	Coarse coating; Contains Boron Nitride.
DYCOTE F 140	35µm	1:3 - 1:5	High insulating.
DYCOTE 140 and DYCOTE 140 ESS	30µm	1:3 - 1:5	General use. ESS version with extra binder.
DYCOTE 32 ESS	30µm	1:3 - 1:5	Medium insulating coating, effective for alloy wheels.
DYCOTE D 34 and DYCOTE D 34 ESS	80µm	1:3 - 1:5	Highly insulating coating for thin section castings typically automotive. ESS version with extra binder.
DYCOTE 3480	75µm	1:3 - 1:5	As DYCOTE 34 ESS but with modified, improved binder
DYCOTE F 34	50µm	1:3 - 1:5	General use.
DYCOTE D 5	45µm	1:3 - 1:5	General use.
DYCOTE D 6 ESS	85µm	1:3 - 1:5	Very highly insulating coating for thin section castings. Textured casting finish.
DYCOTE D 6 ESSB	85µm	1:3 - 1:5	As DYCOTE D 6 ESS + extra binder.
DYCOTE 6	70µm	1:3 - 1:4	High insulation coating for general engineering castings.
DYCOTE 2040	35µm	1:1 - 1:3	Insulating coating with medium particles.

DYCOTE 2050	35µm	1:2 - 1:3	For thicker section automotive castings offering longer lifetime.
DYCOTE 3975	30µm	1:1 - 1:3	Very smooth coating. Contains Boron Nitride.
DYCOTE 3950	15µm	1:2 - 1:3	Used on front face of wheels offering longer lifetime.
DYCOTE V 7	50µm	1:1 - 1:2	Highly insulating coating for actively cooled moulds.

Type of coating	Grain size	Thinning ratio	Application, Description
Heat conducting coatings			
DYCOTE 40	1µm	-	Oil graphite blend for slides and moving parts.
DYCOTE D 38	5µm	1:10	Fully colloidal graphite lubricating coating without binder.
DYCOTE 11	15µm	1:5 - 1:15	Water-based semi colloidal graphite for release of castings from die. Without binder.
DYCOTE 36	35µm	1:3 - 1:5	As DYCOTE D 11, + binder
DYCOTE D 212F	70µm	1:5 - 1:15	Coarse graphite-based coating for release. Without binder.
DYCOTE E 11	20µm	1:5 - 1:15	Semi-colloidal graphite. Without binder.
DYCOTE 11 I	70µm	1:5 - 1:15	Semi-colloidal graphite. For fast cooling and good release. Without binder.
DYCOTE F 36	50µm	1:3 - 1:5	Medium insulating DYCOTE / good surface finishing and good release for small pins with low draft angles.
DYCOTE 38	25µm	1:10	Water-based graphite for release purposes. Thinner than DYCOTE 11.
DYCOTE 61	30µm	1:10 - 1:30	Brass die-casting

Riser and ingate coating	
DYCOTE 7029	Use undiluted or diluted only with water; application by brushing; layer thickness up to 4 mm possible

Other	
DYCOTE HARDENER	Sodium silicate suitable for DYCOTE
DYCOTE 100 M	Coating for automatic ladles
DYCOTE W	Coating for automatic ladles
DYCOTE SAFEGUARD 12	1:1 Top coating to be applied on existing standard DYCOTE product to extend lifetime
DYCOTE SAFEGUARD 15	- As DYCOTE SAFEGUARD 12 but ready to use version without additional dilution

Types		DURA 500	DURA 510	DURA 520	DURA 400	DURA 410	DURA 420	DURA 310
Grain size		78 µm	78 µm	65 µm	50 µm	50 µm	35 µm	35 µm
Density		1.38 kg/ltr.	1.45 kg/ltr.	1.58 kg/ltr.	1.63 kg/ltr.	1.29 kg/ltr.	1.47 kg/ltr.	1.54 kg/ltr.
Packaging	Part 1	5.5 kg = 4 ltr.	5.5 kg = 3,8 ltr.	6.3 kg = 4 ltr.	6.5 kg = 4 ltr.	5.2 kg = 4 ltr.	5.9 kg = 4 ltr.	6.2 kg = 4 ltr.
	Part 2	2.8 kg = 2 ltr.	2.8 kg = 2 ltr.	2.8 kg = 2 ltr.	2.8 kg = 2 ltr.	2.8 kg = 2 ltr.	2.8 kg = 2 ltr.	2.8 kg = 2 ltr.
Water addition to Part 1		8 ltr.	8 ltr.	8 ltr.	4 ltr.	8 ltr.	4 ltr.	8 ltr.
Mix ratio (Vol.): Part 1 : Water : Part 2		1 : 2 : 0,5	1 : 2 : 0,5	1 : 2 : 0,5	1 : 1 : 0,5	1 : 2 : 0,5	1 : 1 : 0,5	1 : 2 : 0,5
Typical extra water addition to get spraying consistency		1 Part = 4 ltr.	0-1 Part = 0-4 ltr.	0-1 Part = 0-4 ltr.	0.8 Parts = 3.2 ltr.	1 Part = 4 ltr.	0.8 Parts = 3.2 ltr.	0.5 Parts = 2 ltr.

DYCOTE coatings are available in different pack sizes.

All DYCOTE coatings are frost sensitive, store between 5 and 25 °C.



### Selection of DYCOTE coatings

A number of factors must be taken into consideration when selecting a DYCOTE.

The section thickness of the casting. One of the main properties of a coating is its ability to aid the filling of the die. When the casting concerned has a thin section then a coarse DYCOTE with high insulation properties should be considered.

The surface finish requirement of a casting is very important but coatings which give very good surface finish make it more difficult to fill the die because of the smooth surface of the coating and because the insulation is not as good as with a coarser coating. The balance of surface finish and insulation will therefore be a compromise.

The geometry of casting can also be critical for good feeding. If a casting has certain thick sections then a specific coating may be required to help directional solidification.

Where a casting has small draft angles, because of design, then a coating with excellent release may be required.

The casting process may also influence DYCOTE selection. For example low-pressure castings can be made with smoother coatings as the process enables the die to be filled more easily.

### Some causes of problems experienced with permanent die coatings

- + Flaking Of Coating
- + Coating Wears Away Quickly
- + Coating Won't Stick To The Die
- + Coating Is Too Rough
- + Misruns / Cold Shuts

Flaking of Coating	Coating wears away quickly	Coating will not adhere to the Die	Coating surface is too uneven	Misruns / Cold Shuts
Layer too thick	Spray distance too great	Coating has been frozen	Coating is under-diluted	Incorrect coating selection
Coating under-diluted	Die too hot	Lack of die surface preparation	Spray distance too short	Insulating coating layer too thin
Lack of surface preparation - poor cleaning	Coating under-diluted	Die temperature too low / high	Plugged or worn spray nozzle	Coating too smooth
Die temperature too low	Coating has been frozen		Low spray pressure	
	Contaminated coating			

## Appendix 1 – Die cleaning with CO<sub>2</sub>

The technique known as „cryogenic“ blasting is carried out by projecting pellets of solid carbon dioxide (dry ice) onto the die, instead of the usual sand or metal shot. Use of non-abrasive dry ice removes the coating without causing damage or wear to the die. In fact the action performed is exclusively kinetic and thermal. Carbon dioxide pellets, after striking the surface of the die, sublime (pass into the vapour state) without producing deposits or wetting the die. The temperature loss of the die is very limited, and it is possible to proceed with another coating in a short time.

With this system, which is becoming increasingly popular in foundries, frequent coatings can be applied, increasing the life of the die and avoiding the problems met when using sand or shot. A further advantage of this process is that the die can be cleaned directly on the casting machine, which reduces down time. The disadvantage is, coatings with long lifetimes may be difficult to remove with this technique.

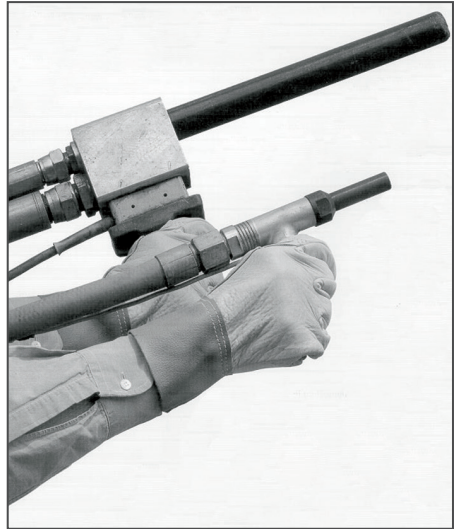

Figure 21: Sandblasting system



Figure 22: Parts of the sandblasting system

## Appendix 2 - Coating Method Defects

### Cause

Build up of coating material restricts airflow in hole „A”, with consequent increase of air flow in the hole opposite and direction of spray to the obstructed side.

### Remedy

Remove the build up (with diluents) without using metal instruments that could damage the nozzle.

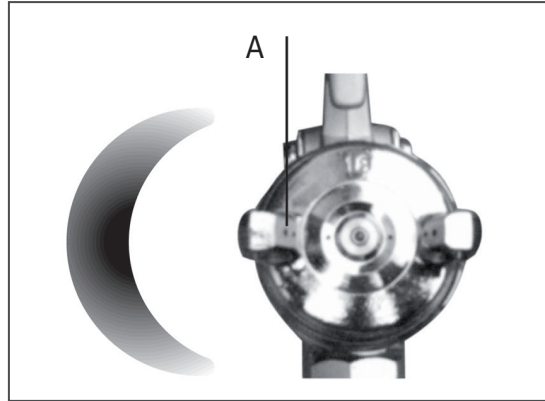

### Cause

1) Build up of coating material around the nozzle on side „B” restricting the flow of atomising air.

2) Air loss, or nozzle tilted or dented, or bent needle.

### Remedy

1) Remove the build up (with diluents) without using metal instruments that could damage the nozzle.

2) Change the nozzle and/or needle.

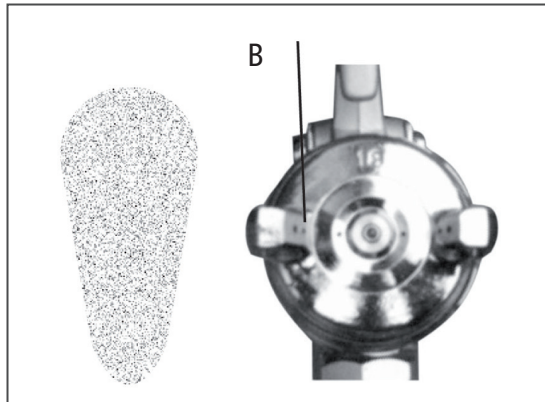

### Cause

Air trapped in coating material, due to absence or wear of the seals, defective collar or punctured aspiration pipe.

Remedy  
Check all seals for tightness and check all points where air might be sucked into the coating material.

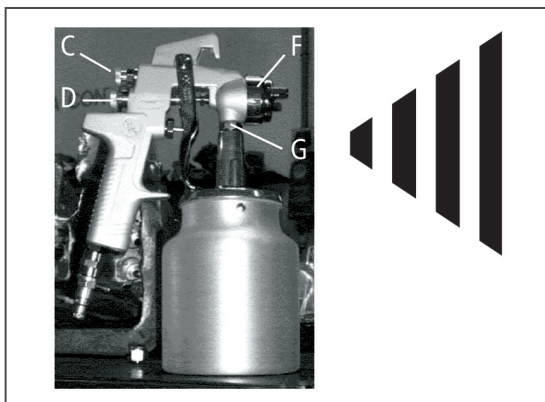

**Cause**

Spray split in two:

- 1) Air pressure too high.
- 2) Coating diffuser aperture too large in relation to the dilution of the coating.
- 3) Shortage of product in the tank.

**Remedy**

- 1) Reduce air pressure.
- 2) Reduce aperture of diffuser (regulators „C“ and „D“).

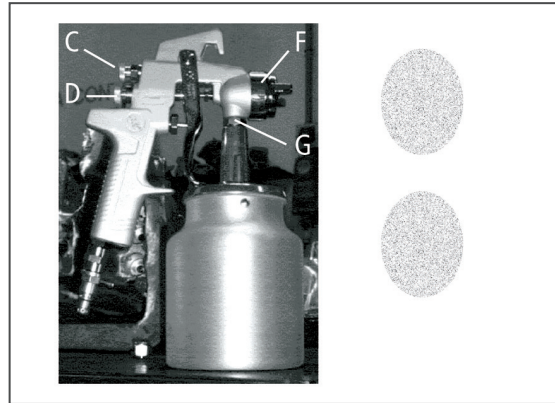

**Cause**

“Salt and pepper” spray effect caused by insufficient pressure or coating too thick.

**Remedy**

Increase spray pressure.

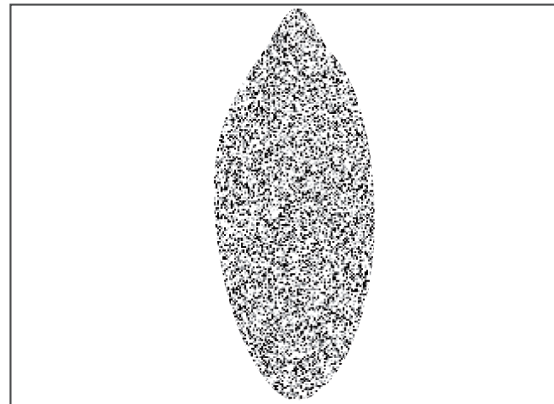

**Foseco International Limited**  
Drayton Manor Business Park,  
Tamworth, Staffordshire,  
England B78 3TL  
Phone: +44 (0)1827 262021  
Fax: +44 (0)1827 283725  
[www.foseco.com](http://www.foseco.com)

**Please contact your local Foseco team**

\*FOSECO, the Logo and DYCOTE are trade marks of the Vesuvius Group, registered in certain countries, used under licence. All rights reserved. No part of this publication may be reproduced, stored in a retrieval system of any nature or transmitted in any form or by any means, including photocopying and recording, without the written permission of the copyright holder or as expressly permitted by law. Applications for permission shall be made to the publisher at the address mentioned.

Warning: The doing of an unauthorised act in relation to a copyright work may result in both a civil claim for damages and criminal prosecution. All statement, information and data contained herein are published as a guide and although believed to be accurate and reliable (having regard to the manufacturer's practical experience) neither the manufacturer, licensor, seller nor publisher represents nor warrants, expressly or impliedly: (1) their accuracy/reliability, (2) that the use of the product(s) will not infringe third party rights, (3) that no further safety measures are required to meet local legislation. The seller is not authorised to make representations nor contract on behalf of the manufacturer/licensor. All sales by the manufacturer/seller are based on their respective conditions of sale available on request.

© Foseco International Limited 03/18.



**FOSECO. YOUR PARTNER TO BUILD ON.**